



Check Here If You Want To Open Links In A New Window



AC6V's HOMEBREW ANTENNAS LINKS



BUT FIRST THE COMMERCIALS

 [NOW AVAILABLE AT HAM STORES](#)

HAM BOOKS BY AC6V

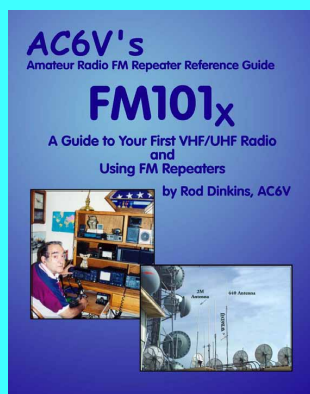

[**DX101x**](#)

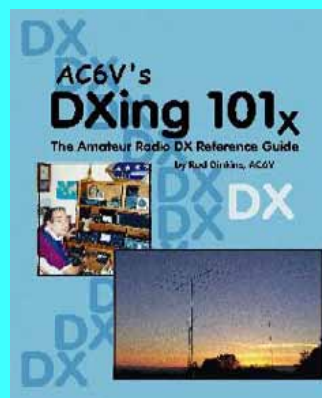

[**FM101x**](#)

DX101 AND FM101 NOW AVAILABLE AT HAM STORES -- CLICK ON BOOK TITLE FOR OUTLINE, SAMPLES AND STORES

[See Reader Reviews Of DX101x](#)

[See Reader Reviews Of FM101x](#)

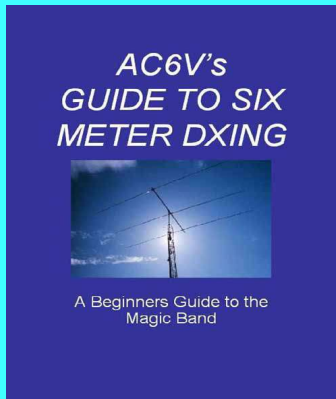

← COMING SOON →

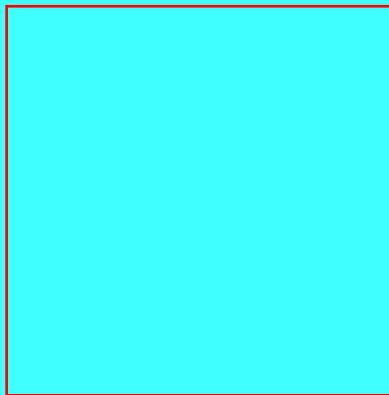

[SIX METERS](#)

[CROSSWORDS](#)



Note

The following antenna projects were gathered from the internet, therefore the author does not endorse any of the projects, you are on your own.

THIS PAGE IS ABOUT HOMEBREW ANTENNAS.
FOR COMMERCIAL ANTENNAS [CLICK HERE](#)

 CHOOSE YOUR AREA OF INTEREST 

[THEORY](#) [MAJOR ANTENNA PAGES](#) [GENERAL](#)
[STEALTH](#) [SWL ANTENNAS](#) [TOWERS](#) [BOOKS](#)

[160M](#) [80M](#) [40M](#) [20M](#) [17M](#) [15M](#) [12M](#) [10M](#) [6M](#) [2M](#) [440Mhz](#) [220MHz](#) [900MHz](#) [GHZ](#)
[HF MULTI-BAND & TRI-BANDERS](#)
[ANTENNA SOFTWARE PROGRAMS](#)

[A](#) [B](#) [C](#) [D](#) [E](#) [F](#) [G](#) [H](#) [I](#) [J](#) [K](#) [L](#) [M](#) [N](#) [O](#) [P](#) [Q](#) [R](#) [S](#) [T](#) [U](#) [V](#) [W](#) [X](#) [Y](#) [Z](#)

Or To Search
Use CNTRL F Or The Find Command In Your Browser

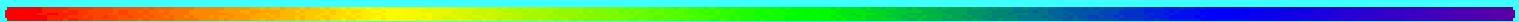

ANTENNA THEORY AND BASICS

[Antenna Basics and Theory](#) -- WOW -- See this One -- From Navy Training Series

[Antenna Basics and Theory](#) -- From Ian C. Purdie, VK2TIP

[Antenna Basics and Theory](#) -- Excellent Tutorial From Scott's Pages

[Antenna Basics and Theory](#) -- Excellent From Integrated Publishing

[Antenna Basics and Theory](#) -- From Sub-TV

[Antenna Basic Radiation Theory](#)-- From The ARRL

[Antenna Basics and Theory](#) -- Excellent - From VK2DQ

[Antenna Construction Tips And Practices](#) -- From KQ6RH

[Antenna Construction Tips -- Metals to use.](#) From Bob Hejl - W2IK

[Antenna Dimension Calculators](#) -- From The Antenna Elmer - Click On Antenna Type

[Antenna Dimension Calculators](#) -- Inverted Vee And Dipoles

[Antenna Dimensions Calculator](#)-- Diploes From AMANDX

[Antenna Dimensions Calculators](#) -- Loops, Dipoles, Delta Loop, and 5/8 waves -- KK5HY

[Antenna Gain](#) -- From L. B. Cebik

[Antenna Height?](#) -- How High Should They Be? -- By Mike Banz, AA3RL

[Antenna Tuner Theory](#) -- From The ARRL

[Antenna Tuners and SWR](#) -- From The ARRL

[Baluns](#) -- IZ7ATH

[Baluns and Choke Baluns](#) -- From Ian C. Purdie, VK2TIP

[Baluns - W8JI Antenna Articles](#) Toroid Balun Winding * Balun and Transformer Core Selection *

Transmitting Baluns

[Choosing Wire For An Antenna](#)

[Dipole End Insulator Installation](#) -- Lots of photos From NorthWest Antennas

[Ground & Radial Systems](#) -- From Butternut

[Height Of Dipoles](#) - Patterns By AA3RL

[Loaded Antennas](#) - From Tom W8JI

[Noise](#) -- Technical article about noise and receiving/ receiving antennas From Tom W8JI

[NVIS I](#)- Near Vertical Incident Skywave Antennas -- By Patricia Gibbons - WA6UBE

[NVIS II](#) - Near Vertical Incident Skywave Antennas Via WB5UDE

[QuarterWave Antenna installation notes](#) -- includes ground/raised radial info -- From Butternut

[Radiation And Fields](#) -- From Tom W8JI

[Radiation Resistance](#) -- From Tom W8JI

[Slingshot method for hanging SkyWires](#)

[Tower Topics, Raising, Specs](#) -- Several Links

[Traps - How do they work ?](#) Excellent - From VK2DQ

[Traps](#) -- Excellent From Tom W8JI

[Trees](#) -- Getting an Antenna Up in em -- From G3CWI

[Vertical Antennas](#) - Dirty Little Secrets, Ground/Radial Systems - Click On Tech Notes

[VHF & UHF Improved Antennas Over A Rubber Duck](#)

[The Effects of VSWR on Transmitted Power](#) --By James G. Lee, W6VAT

MAJOR ANTENNA PAGES

[The Antenna Elmer By AC3L & N3LSS](#) -- Design your own HF/VHF/UHF dipoles, Folded dipoles, Inverted Vees, Ground Plane, Half Wave Vertical, 5/8 Wave Vertical, Quads, 2 Meter Beams, Quarter wave line matching and lots more.

[Antenna Topics From G3YCC](#) -- Loaded with antenna projects -- At least 20+ projects to choose from. **Includes info on the Autek and MFJ259 Antenna Analyzers.**

[ARRL Antenna Projects Web Page](#) -- Includes Beams/Yagis, Dipoles, J-Poles, Loops, Mobiles, Quads, Slopers, Trapped Antennas, Verticals, Other HF Antennas, VHF Antennas

[Antennas A Bunch](#) -- From Ham Radio Spectrum

[Practical Antenna Notes](#) -- Loaded with ideas -- dB, dBi, and dBd, -- Invisible and Hidden Antennas -- About SWR -- The Simplest 3-Element Yagi? --- All Via L. B. Cebik

[Antenna Application Notes](#) -- From Eagle 1St -- Antenna and Feedline Measurements, Return Loss Bridge Basics, Duplexer Tuning using Bridge, Replaceable Pin "N" Connector, Reflected Power Measurements, Spectrum Analyzer Measurements.

[Antenna Design and Software](#) From G4FGQ -- Loaded -- many antenna design programs, coax rating, ferrites and toroids, Groundwave propagation, much much more.

[N1LO'S Antenna Page](#) -- lots of projects - 2M, Monoband HF and Multiband HF

[N4UJW Antenna Design Lab](#) --- Loaded

[W8JI Antenna Articles](#) -- Receiving * Crossfire Phasing * Transmitting * Combiner and Splitters * Toroid Balun Winding * Balun and Transformer Core Selection * Omega and Gamma Matching * Detuning Towers * Radiation Resistance * Transmitting Baluns * Traps * Loading Inductors * Radiation and Fields * E-H Antenna * Phasing Systems * Mobile and Loaded Antennas

[Antenna Magic](#) by Ray Jurgens KQ6RH -- VK2ABQ wire beams, Reflected M beams, Quad Loops, Light Weight Cubic Quads, Pfeiffer Quads, Half Square, Quickie Vertical, X-Beams, Dipoles, Construction Hints, Properties of Fiberglass Rods and Tubes

GENERAL ANTENNA PAGES ALPHABETICALLY OR BY BAND

[A](#) [B](#) [C](#) [D](#) [E](#) [F](#) [G](#) [H](#) [I](#) [J](#) [K](#) [L](#) [M](#) [N](#) [O](#) [P](#) [Q](#) [R](#) [S](#) [T](#) [U](#) [V](#) [W](#) [X](#) [Y](#) [Z](#)

[160M](#) [80M](#) [40M](#) [20M](#) [17M](#) [15M](#) [12M](#) [10M](#) [6M](#) [2M](#) [440Mhz](#) [220MHz](#) [900MHz](#)

[GHZ ANTENNAS](#)

[HF MULTI-BAND & TRI-BANDERS](#)

[STEALTH](#)

Or To Search

Use CNTRL F Or The Find Command In Your Browser

[AM Loop Antennas](#)

[Antennas from QRZ Shareware](#) -- over 40 antenna files

[ARRL Antenna Projects](#) Loaded With Many Antenna Projects

[AA3PX Antenna Page](#) -- Conversations with Dr. Harold H. Beverage

[Antenna Analyzers](#) -- Discussion From G3YCC Pages

[Antenna Analyzers](#) -- Manufacturers

[Antenna Discussions](#) -- Lots Of Antenna Info From the CQ Contest Archives

[Antenna Discussions](#) -- Tons of Antenna & Tower Info From the Tower Talk Archives

[Antennas for Portable Use](#) -- Comparisons

[Antenna Height?](#) -- How High Should They Be? -- By Mike Banz, AA3RL

[Antenna Magic](#) -- Ray Jurgens KQ6RH

[Antenna Projects From The YCCC](#) -- Double-L For 80/160, Two Wire Beverage, A Poor Man's 160 Meter 4-Square, Using a 4 square Vertical Phased Array to improve your 80 and 160 meter signal, -- From The Yankee Clipper Contest Club

[Antenna System Evaluator](#) -- From KD6DKS

[Antennex](#) -- The Ham Antenna Magazine -- all about antennas -- on line

[All-band Wire Antenna](#) - From Joe Tyburczy, WB1GFH

[BackPack Antennas](#) -- From HFpack, The HF Portable Group.

[Balloon and Kite Antennas](#) On The Top Band -- From G4VGO

[Balloon Antennas](#) -- From HCDX

[Baluns](#) From IZ7ATH

[Battle Creek Special](#) -- Info From PI4CC Contest Club

[Battle Creek Special](#) -- Info From OK1RR -- Under Antennas_

[Bazooka Antennas](#) -- From WE6W

[DOUBLE BAZOOKA](#)

[Beams/Yagis](#) -- From The ARRL

[Beverage Antennas](#) -- From KB1GW

[Birdcage Antenna](#) -- Via L. B. Cebik

[Broadside Arrays](#) -- From Integrated publications

[Broomstick Special](#) -- A compact, easy-to-build shortwave antenna

[BuddiPole](#) -- From W3FF

[Cage Doublet](#) -- From The Curmudgeon's Corner

[Carolina Windoms](#) - W2BLC

[Coax Connector Installation](#)

[Coaxial Monopole](#) -- From OE1MWW

[Coaxial Collinear Antennas](#)

[COILS Base](#), Top Loading, Matching Networks, SWR, Open Wire Line -- Tons More From G4FGQ

[Collinear Arrays](#) -- From Integrated publications

[Corner Reflector Antennas](#) -- From By VE3RGW_

[Cross Field Antennas](#) -- by Maurice C. Hatley GM3HAT & Ted Hart W5QJR

[Cross Field Antenna Construction](#) By G3YCC _

[Cubical Quad Antenna Calculator](#) -- From KD6DKS

[Cubical Quad Antenna Design](#) -- By: Dr. Carl O. Jelinek N6VNG

[Cubical Quads](#) By EI7BA

[Cubical Quads](#) -- From KQ6RH

[Cubical Quad Antennas](#) --- From The ARRL

[Cubical Quads 10-12-15 Meters](#) From IZ7ATH

[Cubical Quad - Multiband](#) - By EI7BA

[Cubical Quad loops](#) - From KQ6RH

[Cushcraft R5 Vertical Maintenance and Repair](#) -- Click on ANT, then the little colored circle next to the word Cushcraft. Nice article well done

[Delta Loop - 15M](#)

[DCTL Antenna](#) Compact Antennas - By WA6QBU

[DDRR Antennas](#)

[Dipoles](#) -- From The ARRL

[Dipole Antenna Calculator](#) and construction details -- From AMANDX

[Dipoles and Inverted Vees](#) -- By W4RLD

[Dipole Dual DX Antenna](#) - 20 and 15 meters From NB6Z

[Dipoles, Rotatable](#) -- From KQ6RH

[Discone Antenna Design](#) -- From QRZ_

[Dipole -- Wide-Band Folded Dipole](#) -- By L. B. Cebik, W4RNL

[Dipole Height](#) -- How High??

[DL7PE compact-antennas](#) -- MicroVert, MV-Mobile, MicroDish, MV-500

[Double Extended Zepp Dipole -- Cut for 15 Meters](#)

[Duplexer \(Diplexer\) 2m / 70cm AND Duplexer \(Diplexer\) HF + 6m / 2m + 70 cm](#) HB9ABX

[DX Notebook Antenna Page](#)

[DX Dual Dipole](#) -- From NB6Z

[DXpedition Antennas](#) for Salt Water Locations - Vertical Or Yagi ??

[EH Antenna Forum](#) -- Yahoo

[EH Antennas](#) - How They Really Work From Tom W8JI

[EggBeater Antenna](#) - VHF/UHF From Jerry, K5OE

[EggBeater Antenna](#) - Commercial Product From M squared -- See EB-144 "Eggbeater"

[EME Antennas](#) -- Loaded With Big Antennas

[End-Fire Arrays](#) -- From Integrated publications

[Ferrite Loop Antenna](#) -- for BC band -- From Oceanstate Electronics

[Fiber Glass Rods and Tubes](#) - By KQ6RH

[Four Square Vertical Phased Array](#) -- From The Yankee Clipper Contest Club

[Flags and Pennants](#) -- Receive antennas for limited space with good noise rejection.

[Folded Dipoles](#)

[Four Dollar All Band Antenna](#) -- From Joe Tyburczy, WB1GFH

[Full Wave Loop Antenna](#) 10M thru 80M -- From Western Canada's Ham Radio YL Site

[Full Wave Loop Antenna](#) -- From WH2T Via KQ8RP

[FVR Spitfire Array](#) -- From The Yankee Clipper Contest Club

[G5RV Multi-Band Antenna](#) by Louis Varney

[G5RV Design and length Considerations](#) -- From AA1LL

[Grounding is key to good reception](#)

[Grounding System For Hams](#) - John Wendt WA6BFH

[GRASSWIRE](#) -- By K3MT

[Half Square Antennas](#) -- From K3KY

[Half Square - Elavated](#) By KQ6RH

[Half Wave End Fed, No Radials Antenna](#) -- From G3YCC

[Half Wave End Fed, No Radials Antenna](#) -- From OE3MZC

[Halo Antenna](#) 2M-- From N2K BK

[Halo Antenna](#) 2M Square -- From N4UJW

[Halo Antenna](#) 6M -- From W3DHJ

[HenTenna](#) -- From The N4UJW Antenna Design Lab

[HF All-Band, No-Tuner](#), Horizontal, Center-Fed Antenna From W5DXP

[HF Antennas](#) - Various -- From The ARRL

[HF- and VHF-Yagi-antennas](#) - HomeBrew -- From DK7ZB

[Height Of Dipoles](#) - Patterns By AA3RL

[Helix Antenna, Axial-Mode](#) -- By Dr. D.T. Emerson

[Hexagonal Beam](#) - via EI7BA

[Horizontal Half-wave Dipole above a Counterpoise](#)

[Horizontal Antennas above Real Ground](#)

[IK-STIC](#) -- multi-band vertical dipole antenna used for quick set-up and quick band change -- From W2IK

[IK-STIC 2](#) vertical, all band, antenna, 25 feet tall, under 5 pounds! With a tuner covers the amateur radio HF bands from 40 - 10 Meters.

[Inverted L Antennas](#) By Arnie Coro(CO2KK)

[Inverted Vee](#) - Linear Loaded By KGØZP

[Inverted Vee Antenna](#) -- From The N4UJW Antenna Design Lab

[J-Poles](#) -- From The ARRL

[Super J-Pole Antenna\(Collinear Design\)](#) - By KB0YKI 2M, 220, 440, 6M_

[J-Poles Again](#) -- From Stephen R. Yates, AA5TB

[J-Poles Antennas](#) -- Dimensions, matching, everything -- from Bux CommCo -- Be sure to read importance of a decoupling loop. Also

[Design your Own J-Pole](#) -- Includes J-Pole calculator

[K3KY Low Band Antennas](#)

[K5DKZ](#) - Lotsa Antenna Schemes including Shunt Feeding a Tower

[KQ6XA](#) -- HF Antenna for the Micro-Light Backpacking Enthusiast

[K6STI Receiving Loop](#)

[K9AY Receiving Loop](#)

[Kite Antennas](#) - From G3CWI

[Kites For Lifting Antennas](#)

[Ladder-Line Back Pack Special](#) -- From W2IK

[Lazy-H Expanded](#) From L. B. Cebik

[Liquid Antennas](#) -- Not April 1 stuff

[Log Periodic Antenna Calculator](#)

[Long Wire Antenna](#)

[Long Wire Impedance matching](#)

[Full Wave Loop Antenna](#) 10M thru 80M -- From Western Canada's Ham Radio YL Site

[Full Wave Loop Antenna](#) -- From WH2T Via KQ8RP

[Loops](#) -- From The ARRL

[Loop Antenna for HF Receiving](#) -- From K7ZB

[Loop Antenna](#) - Low Noise Coax for 160 - 10 meters -- From WN6F

[Loop Antennas](#) -- Plans for each Amateur Band

[Loop Antenna Forum](#) -- Yahoo -- Needs subscribing but lots of info here

[Loop Antenna, Magnetic, Portable](#) -- From G4FON

[Low Band Antennas](#) -- From K3KY

[Mac Antenna Master Software](#)

[Magnetic Loops for HF](#) -- From W2BRI

[Magnetic Loops](#) -- By Wolfgang DJ3TZ

[Magnetic Loop Antenna](#) -- From HB9ABX

[Magnetic Loop Design](#) -- From QRZ

[Magnetic Loop Antennas](#) By GM3MXN

[Magnetic Loop Antenna's](#)

[Microwave Antenna HandBook](#) -- From W1GHZ

[Mobile Antennas](#) -- From The ARRL

[Mobile Dual Band VHF/UHF Antenna](#) -- Homebrew Project from VE3RGW

[Mobile Antenna Motorized](#), 98% plastic 5 ft long -- From VE3GK

[Mobile HF Antenna](#) By HB9ABX

[Moxon Antennas](#) Via L. B. Cebik

[Moxon Antenna Projects](#) -- 17M and 20M Via KD6WD

[About Mobile Dual-Band 2m/440](#) -- Roger K6XQ advises - [Can I build a 2m/440mhz 5/8 mobile antenna?](#) A 1/4 wave on 144 MHz is 3/4 wave on 440. The SWR is usually acceptable on the 3rd harmonic, although that is partly due to the increased feeder losses on 440. But SWR is not the whole story. A 3/4 wave radiator on 440 has radiation lobes that send some of your signal at high angles, not toward the horizon where you probably want it. This is usually not so severe to make the antenna unusable, and may be considered a reasonable compromise for the dual band coverage. A 5/8 wave antenna on 144 MHz is 15/8 waves on 440. If you do the simple math you will see that on 440 you will have almost a 2 wavelength antenna, which is becoming what we call a "long wire" on the HF bands. As you probably know, a long wire radiates with multiple lobes, the largest of which are toward the ends of the wire. In other words, most of your signal will be radiated up toward the sky. The reason for the coil in commercial dual band antennas is to phase the antenna currents so you actually end up with two colinear elements which both radiate at low angles, reinforcing each other and providing gain. Without the phasing coil you get multiple undesirable lobes. Also keep in mind that 5/8 wave is NOT a resonant length. There are several ways to compensate for the reactance at the base of a 5/8 wave radiator, the easiest being to add a small inductance in series which makes the antenna electrically equivalent to a 3/4 wave. (3/4 wave is resonant, as you have already discovered). Given that the gain advantage of a 5/8 wave antenna over a 1/4 wave antenna is probably not noticeable except under the most difficult conditions, and even then may or may not make a difference, my suggestion is to stick with the 1/4 wave antenna. It is simple and works OK.

[NVIS](#) -- Near Vertical Incident Skywave Antennas

[Petlowany Three-Band Burner Antenna](#) -- Trapless short vertical antenna - Resonant on 20, 15 and 10 meters, without traps, 12 and 17M with a tuner. From David, N5IZU

[Pfeiffer Quad](#) -- From kQ6RH

[Phasing Arrays](#) - Vertical Antennas -- From Butternut

[Portable Antennas](#) -- From The Ham Club At University of Hawaii at Manoa

[Portable Antennas](#) -- From HFPack

[Portable dual-band antenna for 20 and 10 meters.](#) - The Flower Pot Antenna from IZØFYL

[QRZ Shareware Collection antennas](#) -- over 40 antenna files

[Quad Antenna Calculator](#) -- From KD6DKS

[Quad Antenna Design](#) -- By: Dr. Carl O. Jelinek N6VNG

[Quads By EI7BA](#)

[Quads -- From KQ6RH](#)

[Quad Antennas --- From The ARRL](#)

[Quads 10-12-15 Meters](#) From IZ7ATH

[Quad Loops](#) by Ray Jurgens KQ6RH

[Quad - Multiband](#) - By EI7BA

[Design-A-Quad Antenna](#) Via K4ABT

[Quad loops](#) - From KQ6RH

[Reflected M beams](#) by Ray Jurgens KQ6RH

[Rhombic Antennas](#) 30M - 6M -- From KC0FVV

[Rhombic Antennas](#) -- From Integrated publications

[Rhombic Antennas](#) -- From Ian Cummings

[Roof Top Tower](#) -- By KB0YKI

[Rotary Dipole For 17 And 20](#)

[Rubber Duck Antennas](#)

[Satellite Antennas](#)

[Shortwave Receiving Antennas](#)

[Skywire Loop Antenna](#) -- From The ARRL

[Slinky Antennas](#) -- From Antennas and More

[Sloper Antennas](#) -- From The ARRL

[St Louis Vertical](#) -- From The The American QRP Club

[Stealth Antennas](#)

[Sterba Curtain Antennas](#)

[Sterba Curtain Antennas](#) -- From Ham Universe

[Sterba Curtain 40M](#) -- from KB8PGW

[T2FD Antenna](#)

[T-Hunt Antennas](#)

[Telrex Antenna Trap Repair](#) -- From N6KI

[Transmission Line Calculator](#) -- From AA3RL

[Traps](#) From VE3GK

[Trapped Antennas](#) -- From The ARRL

[Turnstile Antennas](#) -- From Integrated publications

[Tower Talk Archives -- Lots of advice from a reflector](#)

[Tower Installation](#) -- Photos From W5AJ

[Tower Installation](#) -- Loaded With Info -- From N1LO

[Tower Installation](#) -- See how KO4BB did it

[Tower/Antenna Raising](#) -- From Dr. Dave

[US Tower Specs, Base Data & More](#)

[Titan Tower Specs, Base Data & More](#) Via Champion Radio

[The Ten Most Common Tower Building Mistakes](#)

[MARC - The Mast, Antenna, And Rotor Calculator](#) Via Champion Radio

[Vee Antennas](#) -- From Integrated publications

[Inverted Vee And Dipole Calculator](#)

[Inverted Vee](#) - Linear Loaded By KGØZP

[Vertical Antennas](#) -- From The ARRL

[Vertical Wide Band 7-21 MHz](#) -- The RXO Unitenna -- from G3RXO

[Vertical Antennas](#) - Dirty Little Secrets, Ground/Radial Systems, Phased Arrays of Short

[Vertical Antennas](#), Why Radials?- **A MUST READ** - From Butternut antennas Click On Tech Notes

[Vertical Antenna](#) - transportable By CT1BYR

[Vertical Antenna Loading Coils](#) -- see LOADCOIL * Design short vertical antenna and loading coil.

From Reg, G4FGQ

[Vertical Antenna Phasing Arrays](#) - From Butternut Antennas

[Short Vertical Antennas and Ground Systems](#) - VK1BRH

[Vertical - Quickie Style](#) -- From KQ6RH

[Vertical Antennas & Ground Screens](#) -- By N6RK

[Vertical Dipole](#) -- from Tom Severt, N2UHC

[Vertical Dipole](#) -- From L. B. Cebik, W4RNL

[VK2ABQ Wire Beams](#) by Ray Jurgens KQ6RH

[VHF Antennas](#) - Various -- From The ARRL

[W5QJR Antenna](#) Via Antennex

[Water Antennas](#) -- Not April 1 stuff

[WaveGuide Tin Can Antennas](#) -- From Gregory Rehm

[Windom Antenna](#) -- From JA7KPI

[Windom Antenna](#) -- From BuxCom

[Windom - 6 Bands](#) - From K3MT and daughter KF4LGR

[Wire Antennas](#) -- Raising and building -- From N1LO

[X-Beams](#) -- By KQ6RH

[Yagi](#) -- OWA -- Optimized Wideband Antenna -- Follow On Page By NW3Z

[Yagi Optimized Wideband Antennas](#) By NW3Z

[Yagi Modeling](#) -- Six Antenna Comparison By L. B. Cebik, W4RNL

[Yagi/Beams](#) -- From The ARRL

[Yagi - Optimized Wideband Antenna](#) (OWA) and Skyhawk, a state-of-the-art trapless tribander

[Yagi Designs](#) - Lots and Lots -- From TEARA - Click on Knowledge Quest, then topic.

[Stacking Yagis](#) -- From The ARRL

[Wire Yagis](#) -- from VE7CA

[Double Extended Zepp Dipole -- Cut for 15 Meters](#)

[Zip Cord Wire](#) As Transmission Lines and Radiators -- From The ARRL -- Click On Other HF Antennas

[ZL Special](#) -- From The ARRL -- Click On Other HF Antennas

► 160 Meter Antennas

[160M/80M Coaxial Receiving Loops](#) -- By KC2TX

[160M Super Linear-Loaded Inverted V](#) By KGØZP

[Balloon and Kite Antennas](#) On The Top Band -- From G4VGO

[Battle Creek Special](#) -- Info From PI4CC Contest Club

[K5OE Antennas](#) -- HF Antennas 40/80/160 55 ft Vertical

[KGØZP Super Linear-Loaded Inverted V](#)

[Low Band Antennas](#) -- From K3KY

[Verkürzte Antennen](#) -- Short Dipoles and Verticals for 160m & 80m -- From DJ9RB

[Skywire Loop Antenna](#) -- From The ARRL

► 80 Meter Antennas

[Antenna Projects From The YCCC](#) -- Double-L For 80/160, Two Wire Beverage, A Poor Man's 160 Meter 4-Square, Using a 4 square Vertical Phased Array to improve your 80 and 160 meter signal, -- From The Yankee Clipper Contest Club

[Verkürzte Antennen](#) -- Short Dipoles and Verticals for 160m & 80m -- From DJ9RB

[160/80/40 Meters - 55-Foot Vertical](#) From K5OE

[VE3GK's Homebrew Site](#) -- 80M Rotating 2 element Quad

[Verkürzte Antennen](#) -- Short Dipoles and Verticals for 160m & 80m -- From DJ9RB

[40M/80M Trap Dipole](#) -- From QRZ

[80/40 Meter Vertical](#) From EI7BA

[80 Meter Vertical](#) (Half length) Monopole From L. B. Cebik, W4RNL

[80 Meter Inverted Vee](#) From GERRY VE3GK

[80/40 Super Loop Antenna](#)

[80 Meter Antenna](#) -- Reduced Size For Small Lots

[2 EL SHORT BOOM 80M YAGI From VE6WZ.](#)

[Short Dipole for 80M -- From 4S7NR](#)

[80 Meter Frame Antenna -- From Harry Lythall - SM0VPO](#)

[Low Noise Coax-Shielded Faraday Loop Antenna For 40M and 80M](#)

[Full Wave Loop Antenna 10M thru 80M -- From Western Canada's Ham Radio YL Site](#)

[Taylor Space Miser 80M Antenna](#)

► 40 Meter Antennas

[40M Shortened Loop -- By Ben Smith, W4KSY Via Antennex](#)

[WB0NNI 40 Meter Linear Loaded Vertical](#)

[K5OE Antennas -- HF Antennas 40/80/160 55 ft Vertical](#)

[St. Louis Vertical -- By Dave Gauding, NF0R](#)

[DDRR - for 40M -- Directional Discontinuity Ring Radiator Antenna](#)

[40M Beam -- From QRZ](#)

[40M Delta Loop](#)

[40M/80M Trap Dipole -- From QRZ](#)

[40 Meter Delta Loop By PY4VE Via K4TX](#)

[Stealth 40M Antenna - From K7ZB](#)

[ShortyForty Dipole -- From FlashWebHost](#)

[Sterba Curtain 40M -- from KB8PGW](#)

[Low Noise Coax-Shielded Faraday Loop Antenna For 40M and 80M](#)

► 20M Antennas

[20M 3 Element Monobander -- From The ARRL](#)

[K5OE Antennas -- HF Antennas - 10/15/20 m Dipoles](#)

[VE3GK's Homebrew Site -- 7Element 20M Yagi 63ft Boom](#)

[20 meter Extended Double Zep From NB6Z](#)

[20M Yagi Optimized Wideband Antenna](#)

[20M Delta Loop](#)

[Moxon Antenna Projects -- 17M and 20M Via KD6WD](#)

[Verticals](#)

► 17M Antennas

[17M Beam Antennas -- From The ARRL](#)

[Moxon Antenna Projects -- 17M and 20M Via KD6WD](#)

[Verticals](#)

▶ 15M Antennas

[15 Meter Beam](#) -- From The ARRL
[K5OE Antennas](#) -- HF Antennas - 10/15/20 m Dipoles
[15M Delta Loop](#)
[15M Yagi Optimized Wideband Antenna](#)
[A One Element V Beam For 15 M](#) From KB4XJ
[Verticals](#)

▶ 12M Antennas

[12M Beam Antennas](#) -- From The ARRL
[Verticals](#)

▶ 10 Meter Antennas

[Two element 10-Meter beam](#) -- From The ARRL
[10 Meter Verticals using modeling](#) -- From NM5K
[10M 3 Elements By DF9CY](#)
[10M Yagis a Bunch](#) -- From The Antenna Elmer
[10M Yagi Optimized Wideband Antenna](#)
[10M Vertical Dipole](#) -- from Tom Severt, N2UHC
[10M Vertical Dipole](#) -- From L. B. Cebik, W4RNL

HF TRI-BANDERS & MULTIBANDERS

[5 Band Log Periodic Dipole Array](#) -- From VE7CA
[12- and 17-meter lightweight Yagi](#) -- From The ARRL
[30-17-12 Meter Moxon Rectangles](#) - From L. B. Cebik
[All-Band Center-Fed Inverted-L](#) -- From L. B. Cebik
[All-band Wire Antenna](#) - From Joe Tyburczy, WB1GFH
[MULTIBAND HF DIPOLE PROJECT](#)
[ONE ELEMENT BEAM 20 THRU 6](#)

[Cobwebb HF Antenna](#) -- 14 - 28 mhz
[Double-L Antenna For 80/160](#) -- Via The YCCC
[Full Wave Loop Antenna](#) 10M thru 80M
[G5RV Multi-Band Antenna](#) by Louis Varney

[IK-STIC](#) -- multi-band vertical dipole antenna used for quick set-up and quick band change -- From W2IK

[IK-STIC 2](#) vertical, all band, antenna, 25 feet tall, under 5 pounds! With a tuner covers the amateur radio HF bands from 40 - 10 Meters.

[Lattin 5 Band Antenna](#) -- BY W4JRW Via G3YCC

[Multiband Antennas](#) -- From The ARRL

[Multiband Dipole Antenna](#) -- From The N4UJW Antenna Design Lab

[MultiBand Quad](#) - By EI7BA

[MultiBand Vee Beam](#) -- Six Band One Element Beam 20 meters thru 6 From LA0HV

[Pedestrian 5-Band Mobile Antenna](#) - From W3FF

[Petlowany Three-Band Burner Antenna](#) -- Trapless short vertical antenna - Resonant on 20, 15 and 10 meters, without traps, 12 and 17M with a tuner. From David, N5IZU

[Portable All Band Antenna](#) -- "IK-STIC" -- a multi-band vertical dipole antenna which can be used in the field for quick set-up and quick band change.

[Quads 10-12-15 Meters](#) From IZ7ATH

[Rotary Dipole FOR 17 AND 20](#)

[Spider Beam Portable Triband Yagi](#) -- 10/15/20M Via Con DF4SA

[Sturba Curtain - All Band](#)

[St. Louis Vertical](#) -- From Dave Gauding, NF0R

[Tri-Band 2 Element Portable Yagi](#) -- From [Markus Hansen, VE7CA](#)

[Two Element Beam I](#) for 10-, 15-, or 20-meters -- From The ARRL

[Two Element Beam II](#) for 10-, 15-, or 20-meters -- From The ARRL

[Vertical Wide Band 7-21 MHz](#) -- The RXO Unitenna -- from G3RXO

[Windom - 6 Bands](#) - From K3MT and daughter KF4LGR

[Windom Multibander](#) -- From BUXCOM

► 6 Meter Antennas

[5/8 Six Meter Vertical](#) -- by G3JVL

[50 Mhz Antennas](#) By ON4ANT

[Six Meter Antennas A Bunch](#) -- From The UKSMG News

[Six Meter Antennas A Bunch](#) -- From 6MT.com

[Copper Cactus J-Pole antenna](#) -- Plans for 52MHz -- By KG0ZP

[Six Meter J-Pole](#) -- By K4ABT

[Super J-Pole Antenna\(Collinear Design\)](#) - By KB0YKI

[Simple Six Meter Dipole](#) Horizontal or Vertical -- By JIM BAUDO

[Six Meter Halo](#) -- From Steve KB1DIG

[Six Meter Halo](#) -- From W3DHJ

[Six Meter Sloop](#) By K0FF

[Six Metre Long-wire Aerial](#) -- By Brian D. Williams, GW0GHF_

[Six Metre Indoor Loop](#) -- By Colen Harlow, G8BTK_

[Six Metre Antenna](#) -- By Maurius - ZR6YY

[Six Meter Base Station Antenna](#) -- By K4ABT

[Six Meter Long Wire Antenna](#) - From GW0GHF

[Moxon Rectangles for 6 Meters](#) -- From W4RNL, L.B. Cebik

[6M and 2M Yagi](#) -- From The Antenna Elmer

[6M Yagis a Bunch](#) -- From The Antenna Elmer

[Six Meter Yagi](#) -- From The ARRL

[Six Meter three-element Yagi](#) -- From The ARRL

[Six Meter Tri-Yagi](#) -- From The ARRL

[50 MHz 6 Element Beam](#) By DF9CY

[Six Meter Monster Beam](#) -- 8 element, 41 foot boom, 14.0 dBi gain, By N6CA_

[Optimised Six-Metre Yagi](#) by Brian Beezley, K6STI

[Two portable 6 meters antennas](#) - two-element quad and a three-element yagi with telescoping elements -- From VE7CA

[Verticals](#)

► 2 Meter Antennas

[2M/440 MHz Dual Band Copper J-Pole](#) From N7QVC

[VHF/UHF Antennas](#) -- By KB0YKI -- J-Poles, Super J-Pole, Omnidirectional, Quads, Yagis

[2 Meter Antennas A Bunch](#) -- From 6M.com

[American Legion J-Pole](#) - Portable roll-up Antenna

[BiQuad For 2m/440](#) - FROM KE4UYP

[6dB COLINEAR VHF ANTENNA](#) -- From Harry Lythall - SM0VPO

[The Simplest Collinear](#) -- From Ross W1HBQ

[DDRR](#) - for 2M -- Directional Discontinuity Ring Radiator Antenna

[Cycloid Collinear, a CP Omni](#) for 2M from Ross W1HBQ

[HO Collinear, a Horizontal Omni](#) for 2M from Ross W1HBQ

[Copper Cactus J-Pole antenna](#) -- Plans for 52, 146, 223.5, 435, 912, and 1265MHZ -- By KG0ZP

[2M Fan Antenna](#) (Yes From an Electrical fan)

[Two Meter Hanging Dipole](#) - From Peter Parker VK3YE

[Grid Yagi](#) -- From Ross W1HBQ

[2M Half Square Antenna With PVC Support](#) -- Via L.B. Cebik W4RNL

[Halo Antenna](#) 2M-- From N2KBK

[Halo Antenna](#) 2M Square -- From N4UJW

[Stacked J-Pole Plans I](#)

[Stacked J-Pole Plans II](#)

[2M Twin lead J-Pole](#) By K4ABT

[2 M 1/2-Wave J-Pole](#) -- VHF-FM (Stealth) Antenna Made From 450-Ohm Ladder Line -- From KB1GTR & KB1DIG

[2M Log-Periodic Dipole Array](#) -- From The ARRL

[2 METER SSB SQUARE LOOP](#) From N4UJW

[N2NJH's Antenna Roundup](#) -- Build a J-Pole for any frequency - Includes an Excel Spreadsheet!, Pocket J-Pole, Half Wave J-Pole, Stacked 5/8, Field 2 meter Colinear, 2 meter Colinear in PVC, 2 meter Halo, Eggbeater Loop Antenna

[PacketRadio Operator's Antenna Handbook](#) -- Antenna Basics, 2M & 6M Antennas

[2m Quagi](#) By W5UN

[2M Quadix](#) -- from Ross W1HBQ

[SlimJim 2M Antenna](#)

[Sperrtof 2M Antenna](#) -- aka Sleeve Dipole or Sleeve J-Pole. By ON4CFC Via Antennex

[Super J-Pole Antenna\(Collinear Design\)](#) - By KB0YKI_

[VHF Magnetic loop](#) By ON1DHT

[Cheap Yagi Antennas for VHF/UHF](#) -- From The Clear Lake Amateur Radio Club

[3 element 2-meter Yagi](#) -- From The ARRL

[5 element 2-meter Yagi](#) -- From The ARRL

[2M 7 Element Yagi](#)

[2M 9 Element Yagi](#)

[2M Yagis a Bunch](#) -- From The Antenna Elmer

2M Yagis. Old TV Antenna Scheme. Submitted by Gary Ruehle. Drive around and find/collect old TV antennas that people are throwing away. My son and I built a dual 6 element stacked yagi for 2 mtr a couple of years ago. TV antennas were all the building materials we used. After the antenna was complete, we could hit 2 different repeaters about 60 mi away using a 1 watt handheld. This antenna is highly directional.

▶ 220 MHZ Antennas

[Cheap Yagi Antennas for VHF/UHF](#) -- From The Clear Lake Amateur Radio Club

[220 MHz Quickie](#) Quarter Wave Antenna -- From Artsci

[220 MHz J Pole Antenna](#) -- From N6ZAV

[Super J-Pole Antenna\(Collinear Design\)](#) - By KB0YKI

► 440 MHz Antennas

[Cheap Yagi Antennas for VHF/UHF](#) -- From The Clear Lake Amateur Radio Club

[Copper Cactus J-Pole antenna](#) -- Plans for 435MHz-- By KG0ZP

[Coaxial Collinear Antenna](#) -- 432 MHz -- From Via N9ZIA

[Small 70cm Yagi](#) -- From The ARRL

[9 dB, 70cm, Collinear Antenna From Coax](#) -- Version I -- From N1HFX

[2M/440 MHz Dual Band Copper J-Pole](#) From N7QVC

[432 8 Element Quagi Antenna](#) By N2K BK

[440 MHz -- 2 Element & 4 Element Yagi's](#) - From The Antenna Elmer

[430 MHz Antennas A Bunch](#)-- From 6MT.com

[Coat Hanger 7dB, 4-El 70cm Yagi](#) -- Simple, cheap, RUGGED & unscrews for field work--via Stan ZL2AJZ

[Super J-Pole Antenna\(Collinear Design\)](#) - By KB0YKI

► 900 MHz Antennas

[900 MHz Antennas A Bunch](#) -- From 6MT.com

[Cheap Yagi Antennas for VHF/UHF](#) -- From The Clear Lake Amateur Radio Club

[Copper Cactus J-Pole antenna](#) -- Plans for 912MHz - By KG0ZP

► GHz Antennas

[GHz Antennas A Bunch](#) -- From 6MT.com

[Copper Cactus J-Pole antenna](#) -- Plans for 1265MHZ -- By KG0ZP

[Cheap Yagi Antennas for VHF/UHF](#) -- From The Clear Lake Amateur Radio Club

[1270Mhz Yagi Antenna](#)

[Microwave Antennas](#) and Greg's Wireless Networking Info Page

[2.4GHz Omni Antenna](#)

[2.4 GHz Sardine Can Antenna](#) -- A Double Quad Bow Tie

[Loop-Uda-Yagi para 2.4 Ghz.](#)

STEALTH ANTENNAS



THE DREADED CC AND R's



CC&R INFO

[Condo Communicator](#) -- Help for Condo and Apartment Dwellers -- From WA5OES

[CC&R's? \(You Got\)](#) -- Info from the ARRL

[K3QK's Legal Resources](#) -- For hams can use it for that "tower project"

[eHam.net CC&R Survival Series](#)

[eHam Forum on Antenna Restrictions](#)

[FCC Fact Sheet - Over-the-Air Reception Devices Rule](#) Preemption of Restrictions on Placement of Direct Broadcast Satellite, Multi-channel Multi-point Distribution Service, and Television Broadcast Antennas.

[Antenna Restrictions?](#) -- From AC6TS

[Antenna Restrictions](#) - How To Chart - From The ARRL

[Antenna Zoning for the Radio Amateur](#) - ARRL Book On legal aspects of antenna restrictions

HOME BREW STEALTH ANTENNAS

[Balcony Antenna](#) -- From Harry Lythall - SM0VPO

[Hidden, Stealth, HF Antennas](#) -- From K3MT -- The GRASSWIRE -- You read it correctly!!

[Hidden, Stealth & Invisible Antennas](#) -- Smartuners for Stealth Antennas From SGC, Inc.

[Hidden Antenna Ideas](#) -- Links Via AC6TS

[Hidden Antenna Ideas](#) Loops, Operation Away From Home, Attic, From N0HC

[Stealth Amateur Radio - Book From The ARRL](#) -- (ISBN: 0-87259-757-1) #7571

[Stealth 40M Antenna](#) - From K7ZB

[RadialWave™ Ground Radial System](#) -- Great for DEED RESTRICTED BASE STATIONS, QRP, BACKPACKING, FIELD DAY, OR EMERGENCY COMMUNICATIONS.

[Stealth Antenna Experiences](#) - From Clif's ham radio connection.

[SGC Smartuners for Stealth Antennas](#) -- Free - Click on "Download your copy today!"

[10M Bent Attic Antenna](#) - A Yagi No Less

[Stealth 40M Antenna](#) - From K7ZB

[2 M 1/2-Wave J-Pole](#) -- VHF-FM (Stealth) Antenna Made From 450-Ohm Ladder Line -- From KB1GTR & KB1DIG

Small Gauge Wire Makes an "Invisible Antenna" [The Wireman](#) sells #26 AWG "Invisible Toughcoat Silky" antenna wire which is a stranded & coated copperweld type, his catalog #534. Amazingly strong for it's size, very abrasion resistant and you have to go looking for it if you're more than twenty feet away from the stuff.

COMMERCIAL ANTENNAS USED FOR STEALTH

[BuddiPole -- W3FF Products](#)

[B&W Balcony/Window Antenna - AP-10A](#)

[CliffDweller II antenna](#)

[End-Fedz](#) -- full length half wave dipoles, but with an important difference. The coax connector is at one end of the dipole, where it is most needed. From Universal Radio

[EZ HANG](#) -- SlingShot & Reel Device for installing wire antennas

[Force 12- 9 Foot Vertical](#)

[Force 12 Aluminum Flag Poles & Antennas](#)

[HamSticks](#)

[Isotron Antennas](#)

[MFJ Apartment Antenna 40 Meters to 2 Meters MFJ-1622](#)

[MFJ Super Loop Antennas](#)

[MFJ ScrewDriver Antennas](#)

[Outbacker Antennas -- Terlin](#)

[Quicksilver Radio Products MinuteMan™ HF Portable Antennas](#)

[Stealth Antennas -- HF Mobile Antennas By VE7BOC](#)

[Texas BugCatcher - GLA Antennas](#)

[Texas Twister - GLA Antennas](#)

[Ventennas -- The Forbes Group](#)

[Ventanna HFP-2 10 Foot HF Antenna -- 6.5 to 30 MHz !!!](#)

[Vern Wright's HF Mobile Antennas, MP1](#)

[WeatherVane Antennas](#)



SOME OF MY FAVORITE ANTENNA BOOKS -- AC6V



[It Is Back In Print -- Ed Knoll's "Easy Up Antennas" - A good One](#)



[New From Ed Knoll "Dipole and Long Wire Antennas"](#)



[The ARRL Antenna Handbook Buy the Book Today](#)



[The Radio Amateur Antenna Handbook By William I. Orr Buy the Book Today!](#)



[Cubical Quad Antennas : How to Build and Adjust Quads -- by William I. Orr Buy the Book Today!](#)



[Beam Antenna Handbook by William I. Orr, Stuart D. Cowan \(Contributor\) Buy the Book Today!](#)



[Simple Low Cost Wire Antennae by Orr, William I. Orr Buy the Book Today!](#)



[Practical Antenna Handbook by Joseph J. Carr Buy the Book Today!](#)



[Antenna Toolkit by Joe Carr, Buy the Book Today!](#)



[Lew McCoy on Antennas Buy the Book Today!](#)



[ON4UN's Low Band DXing -- Great Source For Low band Antennas Buy the Book Today!](#)



[Go To The Software Pages -- For Antenna Simulation Programs](#)



[Commercial Antennas -- Visit AC6V's Antenna Mfgs Links](#)

AC6V's

Amateur Radio Links

[GO BACK TO THE BIG INDEX](#)

AC6V's

Amateur Radio Links

[GO BACK TO THE QUICK INDEX](#)



_AC6V BRAG TAPE



Last Update: September 02, 2004

THE AMATEUR RADIO DX REFERENCE GUIDE

"Best Title On The Subject" -- Universal Radio

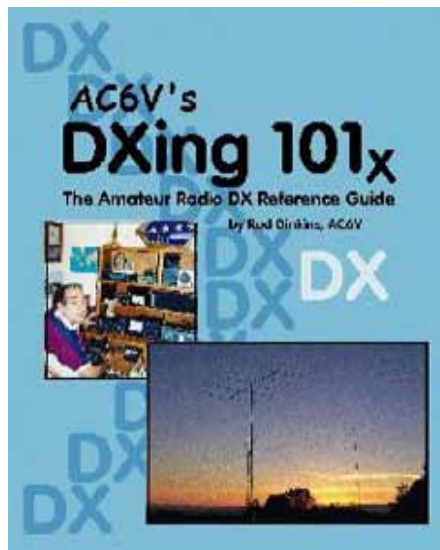

***"This Book Has Been Needed For Years" -- World Radio
Magazine***

***I am sure your book is my "Passport to honour roll" Glyn
GW0ANA***

ALSO AVAILABLE

[FM101x - A Guide to Using FM Repeaters](#)

[Six Meter DXing](#)

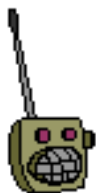

**For Great Programming Accessories
See [Nifty Accessories](#)**



DXing 101x

\$24.95



Money Back If Not Satisfied

1st Priority Shipping Boxed = \$6.00 (USA)

Now Available Book Rate Shipping Boxed = \$3.00 (Allow 2-3 Weeks) (USA)

California Residents, Please Add - 7.75% Sales Tax To Book Price (\$24.95)

Not Set Up For Credit Cards - Sorry

USA Orders Payable (Check Or Postal MO) to

Rod Dinkins AC6V

4982 Marin Drive

Oceanside, CA 92056-4973

For Outside Of The USA - Please See [International Calculator](#) For Shipping Costs
Funds By Your Countries "Bank Check" In US Funds Only" - No Personal Checks

EMAIL AC6V - [CLICK HERE](#)



See DX101x Up Live And Personal At These Ham Stores Or Mail Order

| STORES | MAIL ORDER/CONVENTIONS |
|--|----------------------------|
| BURGHARDT AMATEUR CENTER | BOOKS ETC. |
| GIGAPARTS | HAMSTOP |

| | |
|----------------------------------|--|
| HAM RADIO OUTLET | NIFTY ACCESSORIES - N6FN |
| UNIVERSAL RADIO | QUALITY TECHNICAL BOOKS |
| | ROSEWOOD COMPANY |



[AC6V E-MAIL ADDRESS](#)



This book is a year in the writing and features the DXing advice of several noted DXers and technical gurus. This is not a brag book on my personal DX exploits, but tried and true practical DX advice from those who have been there, done that, and worked them all.

It is intended for those entering into HFing and the wacky world of DXing. Old timers not yet on the Internet will want this book as well.

226 Pages

Deluxe Covers

Book Weighs In At ~1 lb - 11.1 Ounces

Laser Printed On 24 lb Paper, 8-1/2" x 11"

All Chapter Text In 12 Point Times Roman For EZ Reading

Book Is Copyrighted © With United States Library Of Congress

(Author Qualifications -- [The Brag Tape](#) -- Hewlett-Packard Tech Writer - 21 years, Dxr - 24 years)

✓ **DX101X is comb-bound so the latest updates will be inserted prior to all orders as we print on demand. This way all updated URL's, reader feedback, and corrections will be in your manual. As further addendums are received, they will be posted here under**

[MANUAL UPDATES](#)



TESTIMONIALS (UNSOLICITED)

[eHam Reviews](#) -- 16 Reviews From DX101x Owners

World Radio Magazine DX101x Review -- [Click Here](#)

From [Universal Radio Reynoldsburg, OH](#) *We are most impressed with the scope and currentness of this excellent book. Best title on the subject.* [Universal Book Order Page](#)

GW0ANA wrote: Greetings Rod, I would like to thank you & yours first for your amazing book & secondly your taste in "Post Cards". I enjoyed looking at both.

Again I must applaud you for the immense effort you have put in on your book. The subject matter is of great help to Novice & Expert alike. It is like having an "DX Elmer" always at your shoulder.

I just love the relaxed way you impart real DX knowledge to the deserving. Your description on how you caught Malpelo was inspirational to this DX-ER. I got the guy on 10 by abiding by the first law of DX, "Listen & listen again" He popped up on 10 metres on a so called dead band, heard him & got him simplex 100 watts into a mini beam at 30 feet. I have big planning problems. But using wires in trees & lots of listening skill I have 310 countries confirmed & 5BDXCC. Again my thanks for your wonderful book I will dip in & out of it at will.

Best 73 Glyn, GW0ANA, Nirvana Castle Precinct, Wales UK
P/S I am sure your book is my "Passport to honour roll"

Hi Rod. I'm new to ham radio since late Jan of this year (KD7ZHS). I'm sure you've heard this 10,000 times, but your DX book has been an incredible help to me. Ditto for your web site. Hope to meet you on the air some day. Sincerely, Don Keller KD7ZHS

It's like, DXing for Dummies

Best book for DXing for newbies or perhaps anyone. I'm sure even the seasoned pro could glean stuff from here. It's a must have for people like me who know nothing. Well I know something now. This book is laid out logically and is an easy read. I even chuckled a few times. His sense of humor is perfectly timed. But mostly it's so handy and I keep referring too it daily while DXing. It's got useful tricks to DXing and tips on equipment and procedures. Really enjoyed his DXing secrets. IMHO, probably the most important thing is the frequency listings and their uses. I'm hoping that will help standardize things as far as where the DX is. But I'm amazed how knowledgeable AC6V is on this subject. I've got tabs pasted all over it for quick reference and it is right next to me in the ham shack. . . usually opened to something like frequency list or the "Q" codes. Tons of stuff in there like that. I'm VERY glad I bought this one and I don't buy many "how to" books. N5WVN

Fantastic dx book

What a great dx book! When I was called to jury duty I selected THIS BOOK to read while waiting in the jury assembly room! It's a great way to learn and review dxing techniques. Those dxing secrets are great (but don't tell anyone!). I know a lot of work went into this book and I thank and respect all those who worked on it. Another thing that makes it great is the humor mixed in - in fact, I'm asking my local radio club if they want to go on a dxpedition to Charcoal Island in the Barbecues IOTA group! Thank you Rod and everyone for a great book. 73 Martin G. (Marty) Blaise (AG5T)

Rod, 5 star rating. I just bought your DX 101 book, and although I already have snagged 225 countries and have DXCC, I have found quite a few really neat hints and tips that will prove useful. I must admit to reading a bunch of tips and thinking - "Hey that's right, that's what I do . . . ". So I'm learning new stuff and getting a kick out of the "secrets" that I already stumbled upon. Your book will be invaluable to beginners. I hope you can find a publisher who will bind using perfect bound or some regular book binding. . . Best DX and 73, Rich KY6R

Ed Note -- comb binding allows the book to be updated as additions and suggestions come in. These are incorporated into all new books -- books are printed on demand. Updates at URL:

[MANUAL UPDATES](#)

Although licensed for several years, been away from Amateur Radio for about 10 years, so getting restarted with all the new technology and information available was a chore, but DX101X made things a whole lot more enjoyable.

The bottom line is this, I have read the book three times and extracted only a small percentage of the available information; and, if you are either new to our hobby or think you have a strong enough ego not to be humbled but to absorb the information contained in this book, you are in for a very pleasant surprise!

From KB1GZ at [eHam.reviews](#)

Hello Rod, Tks so much fer the book I rcvd hr last week – vy vy psed wid it es still a lot to learn/to pick up; in particular the contesting part. Cuagn 73 de Harry PA3ARM pa3arm@arrl.net

Rod ... Outstanding book! Just got the book in the mail today. I've only had it a short time - but I can't put it down. This book is very well done - outstanding job! I can tell a ton of care and time went into this book. What I like the most about it is it is full of Practical information. I'm learning about stuff I've never really understood until I read this book. I hope you will keep adding to it an updating it. My two cents worth in just the first part of the book I've read - add the Icom - 746 to your list of good contesting HF rigs. I have the Yaesu 1000mp and I'd put the 746's receiver up against it any day. Keep up the great work and thanks for an outstanding book. Feel free to use my comments for your testimonials.73 Dave Sass KC0IWV, Savage MN kc0iwv@mindspring.com

Hi Rod, Thanks very much for sending me an advanced copy of DXing 101x per Paul DeCicco's NN6X request. You've really done an outstanding job in writing a comprehensive text at a beginning and intermediate level for dx'ing. There's a great introductory section on contesting, one of my passions, that should serve the budding contester very well indeed. Included is a very complete treatment of all the important equipment features and performance parameters that the budding dx'er should give attention to when selecting his gear. You've put together in one place information that previously could only be gleaned from countless sources. It really is a unique and rich source of information! 73 Barry N1EU
Delmar NY n1eu@yahoo.com

Rod, All I can say about DX'ing 101X is it is Fantastic. An unbelievable reference for any dx'er. Thanks for your efforts. 73 de N1LQ, David Hammond, Middleton, MA dhhdeh@concentric.net

DX101 contains essential information for the beginner DXer. It is also valuable for the DXer who is seeking to tap the wealth of resources available on the Internet. I am neither and still enjoy reading thru this work. It is well written and deals with all relevant topics - it is a valuable DX tool ! Josh, Grand Junction CO, N7XM
n7xm@qsl.net

Rod, the book arrived and I haven't taken my nose out of it..... I know that a lot of hard work went into getting this book out You would be surprised at all the helpful information that I've already acquired from reading your book.....and I have only gotten through chapter five..... Thanks to you and to all the people that assisted you in making it available to the Ham World.....Best regards..Bill NU5C, North Little Rock, Arkansas
Bdretpd@aol.com

Hello Rod, Just would like to congratulate you on the book. I'm just almost halfway reading it and I've already learned a lot. Considering that I just need a few countries to qualify for DXCC Honor Roll, I still find your book to be an invaluable tool for dx'ers. Congratulations! 73, de Ernie, DU1COO, also KH0DK
ariana@pacific.net.ph

MANY MORE UNSOLICITED TESTIMONIALS -- TOO MANY TO PUBLISH

eHam.net

SOME MORE REVIEWS AT

[MANUAL UPDATES - Click here](#)

TABLE OF CONTENTS

Chapter 1. Introduction

| Paragraph & Topic | Paragraph & Topic |
|--------------------------------|-------------------------------|
| 1-1. How This Book Came About | 1-7. More Joy Of DX |
| 1-2. What Is In This Guide | 1-8. DX Is For All |
| 1-3. Using The Guide | 1-9. DX Clubs And Foundations |
| 1-4. Why DX | 1-10. National Radio Leagues |
| 1-5. The Joy OF DX | 1-11. Awards |
| 1-6. The DXer And The Civilian | 1-12. Brief History Of DXing |

[Click here for a sample of Chapter 1.](#)

Chapter 2. DX Equipment

| Paragraph & Topic | Paragraph & Topic |
|---------------------------------------|--------------------------------|
| 2-2. Transceivers | 2-28. Cubical Quads |
| 2-3. Transceiver Specifications | 2-29. Homebrew Antennas |
| 2-4. Sensitivity | 2-30. Low Band Antennas |
| 2-5. Dynamic range | 2-31. 40 And 30 Meter Antennas |
| 2-6. Selectivity | 2-32. Antenna Gain |
| 2-7. Frequency Stability and Accuracy | 2-33. Towers |

| | |
|--------------------------------------|--|
| 2-8. Cross -Modulation | 2-34. Bearing And Distance |
| 2-9. Gain Compression | 2-35. Grounding And Common Mode |
| 2-10. Intermodulation Distortion | 2-36. RFI Safety & RFI To The Neighbors |
| 2-11. Phase Noise | 2-37. Lightning Protection And Grounding |
| 2-12. S-Units | 2-38. Computer Equipment |
| 2-13. Decibels | 2-39. Cable Management |
| 2-14. Transmitter Specifications | 2-40. Voltage Standing Wave Ratio |
| 2-15. Duty Cycle | 2-41. Antenna Tuners |
| 2-16. Whizbang DSP Radios | 2-42. Microphones |
| 2-17. Transceiver Programmability | 2-43. Headphones And Speakers |
| 2-18. Transceiver Operating Controls | 2-44. ESP Hearing |
| 2-19. Your Sideband Audio | 2-45. Keys And Keyers |
| 2-20. Modifications | 2-46. DSP Units |
| 2-21. Linear Amplifiers | 2-47. Antenna Analyzers |
| 2-22. Selecting Power Amplifiers | 2-48. SWR Meters |
| 2-23. Tubes VS. FETS | 2-49. Phone Patches |
| 2-24. Antennas | 2-50. Scratch Pads |
| 2-25. Antenna Height | 2-51. Monitor Scopes |
| 2-26. Yagi Beams | 2-52. Foot Switches |
| 2-27. Vertical Antennas | 2-53. Other Goodies |

[Click here for a sample of Chapter 2.](#)

Chapter 3. Operating Aids

| Paragraph & Topic | Paragraph & Topic |
|----------------------------------|-----------------------------------|
| 3-2. Logging Programs | 3-13. Propagation Software |
| 3-3. Distance & Bearing Programs | 3-14. Radio Control Programs |
| 3-4. Grayline Programs | 3-15. RTTY, PSK31 & SSTV Programs |
| 3-5. Antenna Programs | 3-16. Prefix List |
| 3-6. NCDXF Beacon Programs | 3-17. CQ and ITU Zones |
| 3-7. DXer Programs | 3-18. Grid Squares |
| 3-8. CW programs | 3-19. Q-Signals & RST |
| 3-9. Great Circle Programs | 3-20. DXer Phonetics |
| 3-10. Prefix Finder Programs | 3-21. CW Abbreviations |
| 3-11. Macintosh Programs | 3-22. Other DX Books |
| 3-12. Propagation Websites | |

[Click here for a sample of Chapter 3.](#)

Chapter 4. Propagation

| Paragraph & Topic | Paragraph & Topic |
|------------------------------------|------------------------------|
| 4-2. The Regions Of The Ionosphere | 4-12. 160 Meters Propagation |
| 4-3. Ionosphere Variations | 4-13. 80 Meters Propagation |

| | |
|-------------------------------------|-----------------------------|
| 4-4. Solar Flux , A Index , K Index | 4-14. 40 Meters Propagation |
| 4-5. Gray Line DXing | 4-15. 30 Meters Propagation |
| 4-6. Backscatter | 4-16. 20 Meters Propagation |
| 4-7. Sporadic E | 4-17. 17 Meters Propagation |
| 4-8. Tropospheric Scatter | 4-18. 15 Meters Propagation |
| 4-9. Ducting | 4-19. 12 Meters Propagation |
| 4-10. Beacons | 4-20. 10 Meters Propagation |
| 4-11. Short Wave Stations | 4-21. 6 Meters Propagation |
| | 4-22. Propagation Graphs |

[Click here for a sample of Chapter 4.](#)

Chapter 5. Working DX

| Paragraph & Topic | Paragraph & Topic |
|------------------------------------|-------------------------------------|
| 5-2. The Big Gun myth | 5-18. Worked All Continents |
| 5-3. Finding DX | 5-19. CQ Magazine Awards |
| 5-4. Listen, Listen | 5-20. World Radio Magazine Awards |
| 5-5. The Pileup Exchange | 5-21. Islands On The Air (IOTA) |
| 5-6. Anatomy of A pileup | 5-22. Awards And Wallpaper |
| 5-7. Working Pileups | 5-23. DX News Letters and Magazines |
| 5-8. Operating Split | 5-24. Prefixes |
| 5-9. Best opportunities To Work DX | 5-25. Common And Rare DX |

| | |
|------------------------------------|---|
| 5-10. Low Band DXing | 5-26. Slashed Calls |
| 5-11. Working Contests | 5-27. Zones |
| 5-12. QRP Operation | 5-28. DX Secrets |
| 5-13. DX Nets | 5-29. USA Band Plans And Power Limits |
| 5-14. Don'ts Of Pileups | 5-30. USA Frequency Allocations |
| 5-15. DX Packet, Telnet, DX Summit | 5-31. Considerate Operator's Freq Guide |
| 5-16. DX Century Club 5-17. WAS | 5-32. Calling Frequencies |
| | 5-33. Six Meter DXing |

[Click here for a sample of Chapter 5.](#)

Chapter 6. QSLing

| Paragraph & Topic | Paragraph & Topic |
|------------------------------|--------------------------------------|
| 6-2. The QSL Card | 6-15. Envelopes |
| 6-3. Logging | 6-16. Envelope Sizes |
| 6-4. QSL Card Design | 6-17. Return Postage |
| 6-5. Finding QSL Addresses | 6-18. Postage Stamps |
| 6-6. QSLing SWL Stations | 6-19. Cash |
| 6-7. Sending QSL Cards | 6-20. Bank Checks |
| 6-8. Sending QSL's Direct | 6-21. IRC's |
| 6-9. QSLing Via A DX Manager | 6-22. Monetary Tips For QSL Managers |

| | |
|------------------------------------|---|
| 6-10. Outgoing QSL Bureaus | 6-23. Current US Postal International Rates |
| 6-11. Incoming QSL Bureaus | 6-24. What Is A Good IRC? |
| 6-12. QSLing To A DX Bureau Direct | 6-25. How Much Postage To Send |
| 6-13. QSL Forwarding Services | 6-26. QSL Checklist |
| 6-14. QSLing Electronically | |

[Click here for a sample of Chapter 6.](#)

Chapter 7. DX Secrets - Over 100 Coveted DX Secrets

[Click here for a sample of Chapter 7.](#)

Chapter 8. Contesting

| Paragraph & Topic | Paragraph & Topic |
|---------------------------------|--------------------------|
| 8-2. Art Of Contesting | 8-6. CW Contesting |
| 8-3. Phone Contesting Equipment | 8-7. Logging |
| 8-4. CW Contesting Equipment | 8-8. Submitting The Logs |
| 8-5. Phone Contesting | 8-9. Check Logs |

[Click here for a sample of Chapter 8.](#)

Appendix A1. CW Operating Procedures

| Paragraph & Topic | Paragraph & Topic |
|-------------------|---------------------|
| A1-2. CW Tutorial | A1-5. Iambic Keying |

| | |
|--|-------------------------------------|
| A1-3. Prosigns For Morse Code | A1-6. Adjusting Paddles |
| A1-4. CW Bandwidth And Character Spacing | A1-7. CW Abbrev, Q-Signals, And RST |

| | |
|-----------------------------------|------------------------------------|
| Appendix A2. CW Abbreviations | Appendix A8. Most Wanted Countries |
| Appendix A3. RST & DXer Phonetics | Appendix A9. Antenna Dimensions |
| Appendix A4. Q-Signals | Appendix A10. DXCC Record Sheets |
| Appendix A5. CQ & ITU Zones | Glossary G |
| Appendix A6. Prefix List | Index I |
| Appendix A7. DX Cluster Commands | |

[Click here for sample of the Appendices](#)

OTHER DX BOOKS

Low Band DXing By ON4UN URL: <http://www.universal-radio.com/catalog/books/3635.html>

The Complete DX'er By W9KNI URL: <http://www.idiompres.com/books-complete-dxer.html>

**Actually you will need all three of these books to completely cover the subject of DXing:
DX101, Low Band DXing, and The Complete DXer.**

Thanks For Stopping by 73



[GO BACK TO THE QUICK INDEX](#)

Updated Tuesday, August 31, 2004

AC6V's GUIDE TO FM REPEATERS

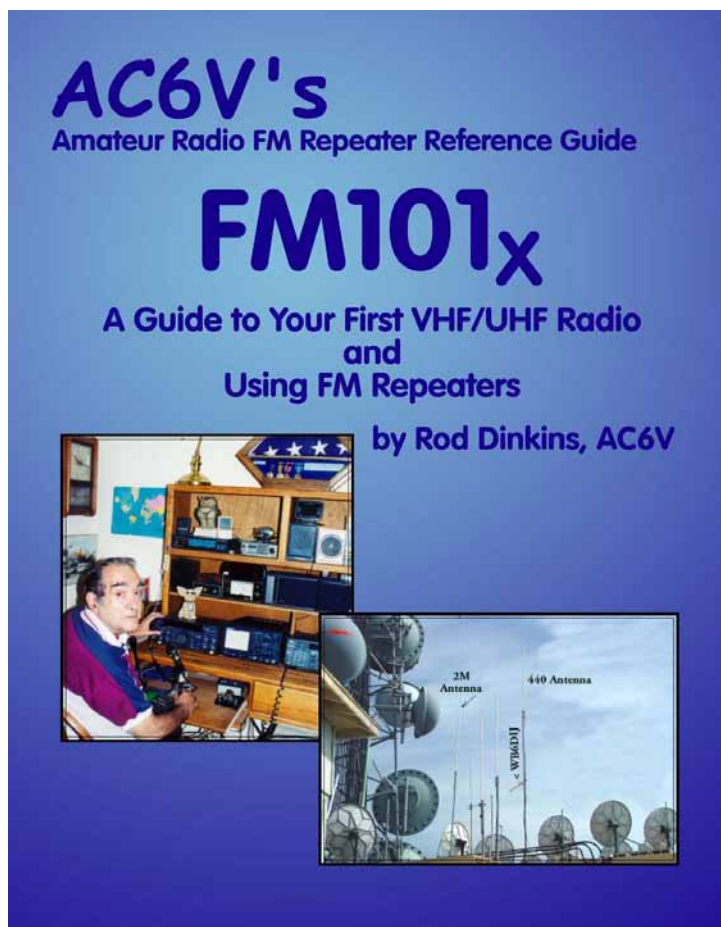

Price \$12.95 Plus Shipping



Money Back If Not Satisfied

1st Priority Shipping = \$3.85 (USA)

Now Available Book Rate Shipping Boxed = \$2.24 (Allow 2-3 Weeks) (USA)

California Residents, Please Add - 7.75% Sales Tax To Book Price

Not Set Up For Credit Cards - Sorry

USA Orders Payable (Check Or Postal MO) to

Rod Dinkins AC6V

4982 Marin Drive

Oceanside, CA 92056-4973

**For Outside Of The USA - Please See [International Calculator](#) For Shipping Costs
Funds By Your Countries "Bank Check" In US Funds Only" - No Personal Checks**

ALSO AVAILABLE

[DX101x - A Guide For Beginning DXers](#)

[Six Meter DXing](#)



For Great Programming Accessories
See [Nifty Accessories](#)

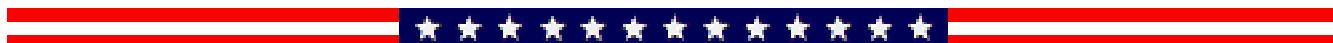

See FM101x Up Live And Personal At These Ham Stores Or Mail Order

| STORES | MAIL ORDER/CONVENTIONS |
|---|---|
| <u>BURGHARDT AMATEUR CENTER</u> | <u>BOOKS ETC.</u> |
| <u>GIGAPARTS</u> | <u>HAMSTOP</u> |
| <u>HAM RADIO OUTLET</u> | <u>NIFTY ACCESSORIES - N6FN</u> |
| <u>UNIVERSAL RADIO</u> | <u>QUALITY TECHNICAL BOOKS</u> |
| | <u>ROSEWOOD COMPANY</u> |

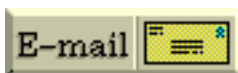

[AC6V E-MAIL ADDRESS](#)



This book is six months in the writing and features the advice of several noted Amateurs and technical gurus.

It is intended for those entering the world of FM Repeaters and Amateur Radio. The guide is written for new users with or without a technical

background

88 Pages

Deluxe Covers

Book Weighs In At ~10.1 Ounces

Laser Printed On 24 lb Paper, 8-1/2" x 11"

All Chapter Text In 12 Point Times Roman For EZ Reading

Book Is Copyrighted © With United States Library Of Congress

(Author Qualifications -- The Brag Tape -- Hewlett-Packard Tech Writer - 21 years, Amateur - 24 years)

✓ **FM 101x is comb-bound so the latest updates will be inserted prior to all orders as we print on demand. This way all updated URL's, reader feedback, and corrections will be in your manual. As further addendums are received, they will be posted here under**

MANUAL UPDATES



SEE E-HAM REVIEWS



TESTIMONIALS (UNSOLICITED)

Universal Radio comments: Many new hams find repeater operation intimidating. This book lets you skip that awkward early stage. It provides the knowledge and confidence you need to enjoy repeater operation immediately.

I would like to send a thanx to you for your book on repeaters. Just starting out in the hobby. I could not have asked for a better guide to the world of fm repeaters. I have now started working 2 m ssb and have logged over 17 grid squares in 4 months. Thanx again for a great start in the hobby. 73 George KG6TVC, San Leandro, CA

KF6HBJ writes -- I purchased the FM101x Guide last week and have gone through the material relating to my HT. Basically I purchased it to bring me up to date as I had dropped off from using my radio quite awhile ago. Being a computer guy, I found the material easy to follow and found the essentials pointing me to further readings on web links for increased knowledge and detail. From the first page to the last page, I never felt slighted because I wasn't a seasoned Ham Radio

Operator. Rod's vernacular clearly expresses what I needed to get accustomed to without the academia sort of information that I have read in other technical types of volumes. Thanks Dave KF6HBJ, Temecula CA

Excellent Book. I recently taught a one day ham class for new technician hams. I purchased a copy of the FM101X book for each student. All the students had many compliments for the contents of the books. One comment "including the book in the course was a very good idea" Another comment "FM101X answered all my questions about repeater operation as a new ham - great book"

The new hams loved it! For new hams this is the book! Dick Decker K6SUU, Turlock CA

N5ACM comments on [eHam reviews](#): Get up to Speed Quickly with this Guide. This book is well worth the price. You get current, practical information on topics of interest to both new and old HAMs. Information is presented in a straightforward, succinct and readable manner, the illustrations are basic, but adequate. You don't need or pay for glossy fluff here- the book provides a well thought out treatise on FM ops in one place, from simplex, repeaters, digital and the vagaries of Echolink. Lots of links for further information too. A great place to get up to speed quickly. New HAMS will feel completely comfortable on VHF/UHF after perusing this book. Well Done. N5ACM, Arlington TX

AB7NI Wrote: Rod, Received the book today. I read it, and was impressed. Great minds must think alike. Your comments were EXACTLY what I have been telling new hams for years. Very much interested in buying in volume for the next class I teach. Meanwhile this copy is getting some yellow highlighted sections. Great job! Thanks -- Gary AB7NI Colbert, WA

KG6JPX Wrote -- Bravo on AC6V'S FM101x. Also, the internet website references are great. However I think it would help a lot if you repeated them in the back of the book, grouped according to their purpose. That would help locate them later on when the reader has forgotten the context, chapter and page number where it was first seen.

Author note -- this will be added --see [MANUAL UPDATES](#)



TABLE OF CONTENTS

[Chapter 1 Introduction - Click Here For Sample](#)

Covers an introduction to the book as well as an example of the bewildering jargon that one will encounter on Amateur Radio Repeaters and where in the book to decipher the alphabet soup and jargon. CTCSS, PL, Offset, Desense, Alligator, Machine, Picket-Fencing, Quieting, Q-Signals, beeps, hang-time, protocol, OM, capturing, etc.

[Chapter 2. Your First FM Radio - Click Here For Sample](#)

Information on what to select as your first FM radio. Discusses advantages of Handi-Talkies vs Mobiles, antennas, batteries, features to consider. All mode radios and multi-banders are discussed. Mobile installation, Mobile Antennas, DC power supplies, Noise Abatement, Mobile Power considerations, Coax Considerations, and VSWR checks.

[Chapter 3. Operating Simplex - Click Here For Sample](#)

Discusses how to operate simplex (without a repeater). Range to be expected, antennas, cross polarization, and protocol. Includes a complete list of simplex frequencies from 2 meters thru 1.2 GHz including the recommended National Calling frequencies. VHF/UHF DXing techniques.

[Chapter 4. How Repeaters Works - Click Here For Sample](#)

Simplified pictorial of a repeater. Covers simplex, half duplex, full duplex operation. Explains offsets, splits, input and output frequencies. Lists the standard offsets for USA repeaters - 10 meters thru 2.4 GHz. Thoroughly covered are **CTCSS, PL, SUBAUDIBLE TONES | TONE SQUELCH | DCS, DTCS | TONE BURST | DTMF | BEEPS & BE-BOPS.**

[Chapter 5. Programming a Rig - Click Here For Sample](#)

Covers the nightmare of programming a radio. How to make a cheat sheet. Using programming cables. A source for a handy wallet size programming accessory. Generic outline for programming any radio.

[Chapter 6. Antennas, Power Sources, VSWR, and DeciBels - Click Here For Sample](#)

Covers rubber duck antennas, better antennas such as $\frac{1}{4}$ wave, $\frac{1}{2}$ wave, $\frac{3}{4}$ wave and $\frac{5}{8}$ wave, Yagis, and J-Poles. Gives numerous URL's and tips for building your own antennas. The battery paragraphs cover Sealed Lead Acid (SLA),

Lithium, NICAD and NIMH Batteries. Power Supplies, VSWR, and dB are covered in a non-technical approach.

Chapter 7. Using Repeaters - [Click Here For Sample](#)

This chapter covers how to find repeaters, repeater guides on the internet, complete rundown on repeater protocol, soliciting a conversation, asking for information, jargon heard, radio checks and signal reports, what to say, breaking in, multiple conversations - rotations, nets, roll calls and demos, autopatching. Also listed is a complete listing of 2 Meter repeater pairs, packet simplex, and voice simplex frequencies.

Chapter 8. Phonetics, Q-Signals, and Callsigns - [Click Here For Sample](#)

All about Q-Signals used on repeaters. Recommended Phonetics are covered (Alpha, Bravo, etc). A list of all USA callsign districts and classes of license callsigns are explained.

Chapter 9. Funny Repeater Sounds and Myths - [Click Here For Sample](#)

Covers the many sounds heard on a repeater, path noise, distortions, alternator whine, ignition noise, capturing, picket fencing, Morse characters, hum, over and under deviation, kerchunk, desense, motor boating, Station is Calling - But No Beep, Q-Signals, CB talk & ten codes (a no no) etc.

Chapter 10. Cops and Jammers - [Click Here For Sample](#)

When and when not to play repeater policeperson. How to deal with jammers and interlopers.

Chapter 11. Inside A Repeater - [Click Here For Sample](#)

Detailed block diagrams of the elements of a repeater, receivers, transmitters. Plain language non-technical discussions of duplexers, limiters, discriminators, deviation, bandwidth, channel spacing, modulation index, FM modulation.

Chapter 12. IRLP, ILINK,ECHOLINK, WIRES II™, CrossBand Repeating, Long Range Intertie Systems, - [Click Here For Sample](#)

Glossary and Jargon -- 16 pages of terms, slang, repeater speak - [Click Here For Sample](#)



[GO BACK TO THE BIG INDEX](#)



[GO BACK TO THE QUICK INDEX](#)

Updated Tuesday, August 31, 2004

Call Search

[Reviews Categories](#) | [Books/Videos/CDROMS on Ham radio](#) | [Help](#)
DXing 101X

Reviews Summary for DXing 101X

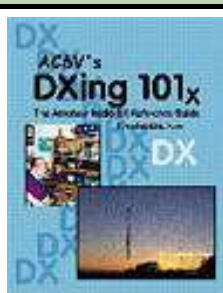

| | | |
|--|--------------------------|-------------------------------|
| Reviews: 19 | Average rating: 5.0/5 | MSRP: \$24.95 plus postage |
| Description: This is a great reference book for all DXers. | | |
| More info: http://ac6v.com/DXSAMPLE.htm | | |

You can [write your own review](#) of the DXing 101X.

Page 1 of 2 [→](#)

| | | | |
|--|-------------|----------------------|--|
| NE5EE | Rating: 5/5 | Jul 3, 2004 20:47 | Send this review to a friend |
| An extensive compendium | | | Time owned: 0 to 3 months |
| I had picked up a copy of FM101x and was quite impressed (I had planned to use it for a followup class for new hams). So I took a look at DX101x too. Wow, it is great! So much info. And lots of stuff I didn't know even tho I have over 200 countries. This book is definitely worth it, right up there with The COmplete DXer. | | | |

| | | | |
|--|-------------|-----------------------|--|
| GW0ANA | Rating: 5/5 | Apr 22, 2004 06:18 | Send this review to a friend |
| A great book very well researched & packed with DX secrets | | | Time owned: 0 to 3 months |

[Dayton 2004 Photos](#)

[New to Ham Radio?](#)

My eHam

[Profile](#)
[Email Subscriptions](#)

Community

[Articles](#)
[Forums](#)
[Friends Remembered](#)
[Speak Out](#)
[Strays](#)
[Survey Question](#)

Operating

[Contesting](#)
[DX Cluster Spots](#)
[Propagation](#)

Resources

[Calendar](#)
[Callbook](#)
[Classifieds](#)
[Ham Exams](#)
[Ham Links](#)

[List Archives](#)
[News Articles](#)
[Product Reviews](#)
[QSL Managers](#)
[Discount Books](#)

Site Info

[About eHam.net](#)
[Support the site](#)
[eHam Help \(FAQ\)](#)
[Vision Statement](#)
[eHam Team](#)
[Help Wanted](#)
[Advertising Info](#)

Sweepstakes



[QSL Managers](#)

[Ham Links](#)

I found it very educational on the subject of HFDX-ing. In fact it was like having your own Elmer in the shack. I have built up a good library of books over 25 years of "hamming" & I can recommend AC6V's book DXing 101X as the Definitive guide. Each chapter is very well laid out in an easy to read format. His writing style is great as it is not bogged down with waffle & padding. It's the facts, the real facts & nothing but the facts. As I told Rod, I am sure with the advice found in his book I am sure it will be my "Passport to DXCC Honour Roll" 73 de Glyn GW0ANA

| | | | |
|---|-------------|--|--|
| VE9VIC | Rating: 5/5 | Feb 16, 2004 20:31 | Send this review to a friend |
| a must | | Time owned: more than 12 months | |
| <p>I HAVE BEEN DXING FOR THE PAST 10 years and this book is really good for the newcomers and for the more experienced dxer's. nice job, it will surely help a lot of new amateurs specially if they don't have or find an Elmer to help them, I also have the complete dxer by w9kni AND LOW BAND dxing by ON4UN, all are a must if you want to improve your skill and have fun, 73 best dx.rino</p> | | | |

| | | | |
|---|-------------|-----------------------------------|--|
| N5VWN | Rating: 5/5 | Dec 31, 2003 06:14 | Send this review to a friend |
| It's like, DXing for Dummies | | Time owned: 6 to 12 months | |
| <p>Best book for DXing for newbies or perhaps anyone. I'm sure even the seasoned pro could glean stuff from here. It's a must have for people like me who know nothing. Well I know something now. This book is laid out logically and is an easy read. I even chuckled a few times. His sense of humor is perfectly timed. But mostly it's so handy and I keep referring to it daily while DXing. It's got useful tricks to DXing and tips on equipment and procedures. Really enjoyed his DXing secrets. IMHO, probably the most important thing is the frequency listings and their uses. I'm hoping that will help standardize things as far as where the DX is. But I'm amazed how knowledgeable AC6V is on this subject. I've got tabs pasted all over it for quick reference and it is right next to me in the ham shack. . . usually opened to something like frequency list or the "Q" codes. Tons of stuff in there like that. I'm VERY glad I bought this one and I don't buy many "how to" books.</p> | | | |

| | | | |
|--|-------------|-----------------------|--|
| KU4BP | Rating: 5/5 | Jul 31, 2003 00:49 | Send this review to a friend |
| Great Book | | | Time owned: 6 to 12 months |
| <p>This book is a must for new DXers and DX veterans alike. The chapter on DX secrets is an invaluable resource because nobody knows every "trick of trade".</p> <p>Ed KU4BP</p> | | | |

| | | | |
|--|-------------|-----------------------|--|
| KE6NHS | Rating: 5/5 | Jul 26, 2003 15:56 | Send this review to a friend |
| Excellent | | | Time owned: 0 to 3 months |
| <p>If you are new to HF this book is your new best friend. All of the basics are well covered. Once you get past the basics, you will find a lot of advanced information that can only be acquired through years of experience. After spending 2 weeks with the book I am still finding valuable information and I am constantly referring to the many operating aids provided. Thank you Rod!</p> | | | |

| | | | |
|---|-------------|-----------------------|--|
| AD6WL | Rating: 5/5 | Jun 25, 2003 17:00 | Send this review to a friend |
| Great book | | | Time owned: more than 12 months |
| <p>This book doesn't have anything in it that I haven't read before, but it has it all in one place. I have read many books, and websites on HF and DXing. This book will save you lots of time by having it all in one easy reference. It is a great book for newcomers to DX and the oldtimers alike.</p> | | | |

| | | | |
|--------------------------|-------------|-----------------------|--|
| N6SDK | Rating: 5/5 | Dec 27, 2002 16:21 | Send this review to a friend |
| Great HF'ing Book | | | Time owned: more than 12 months |

This book has helped me time and time again. It is packed with years of useful information, which the author, Rod AC6V, has learned in through his experiences. It is organized in a straight forward easy to understand manner. I use this book whenever I have unanswered questions or simply want to read about High Frequency Ham Radio operation. I highly recommend it!

| | | | |
|---|-------------|-----------------------|--|
| AG5T | Rating: 5/5 | Dec 26, 2002 12:11 | Send this review to a friend |
| Fantastic dx book | | | Time owned: more than 12 months |
| <p>What a great dx book! When I was called to jury duty I selected THIS BOOK to read while waiting in the jury assembly room! It's a great way to learn and review dxing techniques. Those dxing secrets are great (but don't tell anyone!). I know a lot of work went into this book and I thank and respect all those who worked on it. Another thing that makes it great is the humor mixed in - in fact, I'm asking my local radio club if they want to go on a dxpedition to Charcoal Island in the Barbecues IOTA group! Thank you Rod and everyone for a great book.</p> | | | |

| | | | |
|---|-------------|----------------------|--|
| KB1GZ | Rating: 5/5 | Sep 5, 2002 13:01 | Send this review to a friend |
| Terrific | | | Time owned: 6 to 12 months |
| <p>Although licensed for several years, been away from Amateur Radio for about 10 years, so getting restarted with all the new technology and information available was a chore, but DX101X made things a whole lot more enjoyable.</p> <p>The bottom line is this, I have read the book three times and extracted only a small percentage of the available information; and, if you are either new to our hobby or think you have a strong enough ego not to be humbled but to absorb the information contained in this book, you are in for a very pleasant surprise!</p> | | | |

If you have any questions, problems, or suggestions about Reviews, please email your [Reviews Manager](#).

Copyright 2000-2004 eHam.net, LLC
eHam.net is a community web site for amateur (ham) radio operators around the world.
Contact webmaster1@eHam.Net with comments or questions.

[Site Privacy Statement](#)

This web site is hosted &
created by AkornHosting.com



Enjoy world-class music by an active ham!

[click here](#)

[eHam.net Home](#) | [FAQ](#) | [Log In Help!](#) | [Please Subscribe!](#) [Welcome Anonymous](#) [Become a member!](#) or [Login!](#)

Call Search

[Reviews Categories](#) | [Books/Videos/CDROMS on Ham radio](#) | **FM101x By AC6V - A Beginners Guide To Using FM Repeaters** [Help](#)



[Dayton 2004 Photos](#)

[New to Ham Radio?](#)

My eHam

- [Profile](#)
- [Email Subscriptions](#)

Community

- [Articles](#)
- [Forums](#)
- [Friends Remembered](#)
- [Speak Out](#)
- [Strays](#)
- [Survey Question](#)

Operating

- [Contesting](#)
- [DX Cluster Spots](#)
- [Propagation](#)

Resources

- [Calendar](#)
- [Callbook](#)
- [Classifieds](#)
- [Ham Exams](#)
- [Ham Links](#)

| Reviews Summary for FM101x By AC6V - A Beginners Guide To Using FM Repeaters | | | |
|--|--|-----------------------|---------------|
| | Reviews: 6 | Average rating: 4.7/5 | MSRP: \$12.95 |
| | Description: For the new Ham entering the world of FM repeaters and VHF/UHF. Selecting your first rig, Repeater Operations, Finding and Using Repeaters, Antennas, Installation, Power Sources and Batteries, Protocol, Q-Signals, Jargon revealed - 16 page Glossary. PL, Beeps, Timers, Offset, Hang Time, DCS, DTCS TONE BURST DTMF etc. Desense, Capturing, Path Noise, Quieting, How FM works. | | |
| | More info: http://ac6v.com/FM101.htm | | |

You can [write your own review](#) of the FM101x By AC6V - A Beginners Guide To Using FM Repeaters.

| | | | |
|---|-------------|-----------------------|--|
| KC6TRW | Rating: 5/5 | Aug 28, 2004 16:29 | Send this review to a friend |
| Great book Rod ! Easy reading and good for the beginner | | | Time owned: 3 to 6 months |
| Most folks at the Aircraft factory are now asking for this book so they can conteract being mic shy. Good work Rod! Denis Despins KC6TRW | | | |

| | | | |
|-----------------------|-------------|-----------------------|--|
| NE5EE | Rating: 5/5 | May 25, 2004 16:20 | Send this review to a friend |
|-----------------------|-------------|-----------------------|--|

- List Archives
- News Articles
- Product Reviews
- QSL Managers
- Discount Books

Site Info

- About eHam.net
- Support the site
- eHam Help (FAQ)
- Vision Statement
- eHam Team
- Help Wanted
- Advertising Info

Sweepstakes



QSL Managers

Ham Links

| | |
|---|----------------------------------|
| A terrific fast start | Time owned: 0 to 3 months |
| <p>A new Tech enters the hobby with an HT and little else. This is the place to pick up the rest of what he or she needs to know.</p> <p>I do a lot of coaching and I will be recommending this book from now on. Two years of experience packed into one weekend of easy, pleasurable reading.</p> | |

| | | | |
|--|--------------------|-------------------------------|--|
| KF6HBJ | Rating: 5/5 | Apr 28, 2004 16:29 | Send this review to a friend |
| Book clearly written to be read and used. | | | Time owned: 0 to 3 months |
| <p>"I purchased the FM101x Guide last week and have gone through the material relating to my HT. Basically I purchased it to bring me up to date as I had dropped off from using my radio quite awhile ago. Being a computer guy, I found the material easy to follow and found the essentials pointing me to further readings on web links for increased knowledge and detail. From the first page to the last page, I never felt slighted because I wasn't a seasoned Ham Radio Operator. Rod's vernacular clearly expresses what I needed to get accustomed to without the academia sort of information that I have read in other technical types of volumes. Thanks Rod! 73 Dave - KF6HBJ"</p> | | | |

| | | | |
|---|--------------------|-------------------------------|--|
| K6SUU | Rating: 5/5 | Mar 10, 2004 20:39 | Send this review to a friend |
| excellent book! | | | Time owned: 0 to 3 months |
| <p>I recently taught a one day ham class for new technician hams. I purchased a copy of the FM101X book for each student. All the students had many compliments for the contents of the books. One comment "including the book in the course was a very good idea" Another comment "FM101X answered all my questions about repeater operation as a new ham-great book"</p> <p>For new hams this is the book!</p> <p>Dick Decker K6SUU</p> | | | |

| | | | |
|-----------------------|--------------------|-------------------------------|--|
| N5ACM | Rating: 5/5 | Apr 30, 2003 14:59 | Send this review to a friend |
|-----------------------|--------------------|-------------------------------|--|

| | |
|---|----------------------------------|
| Get up to Speed Quickly with this Guide | Time owned: 0 to 3 months |
| <p>This book is well worth the price. You get current, practical information on topics of interest to both new and old HAMs.</p> <p>Information is presented in a straightforward, succinct and readable manner, the illustrations are basic, but adequate. You don't need or pay for glossy fluff here- the book provides a well thought out treatise on FM ops in one place, from simplex, repeaters, digital and the vagaries of Echolink. Lots of links for further information too.</p> <p>A great place to get up to speed quickly. New HAMS will feel completely comfortable on VHF/UHF after perusing this book. Well Done.</p> | |

| | | | |
|--|--------------------|---------------------------|--|
| NA4M | Rating: 3/5 | Apr 10, 2003 16:37 | Send this review to a friend |
| New Book on FM | | | Time owned: 0 to 3 months |
| New book on FM repeaters. This will be removed when first review posted. | | | |

If you have any questions, problems, or suggestions about Reviews, please email your [Reviews Manager](#).

Copyright 2000-2004 eHam.net, LLC
eHam.net is a community web site for amateur (ham) radio operators around the world.
Contact webmaster1@eHam.Net with comments or questions.

[Site Privacy Statement](#)

This web site is hosted &
created by [AkornHosting.com](#)

SIX METER DXING FOR BEGINNERS

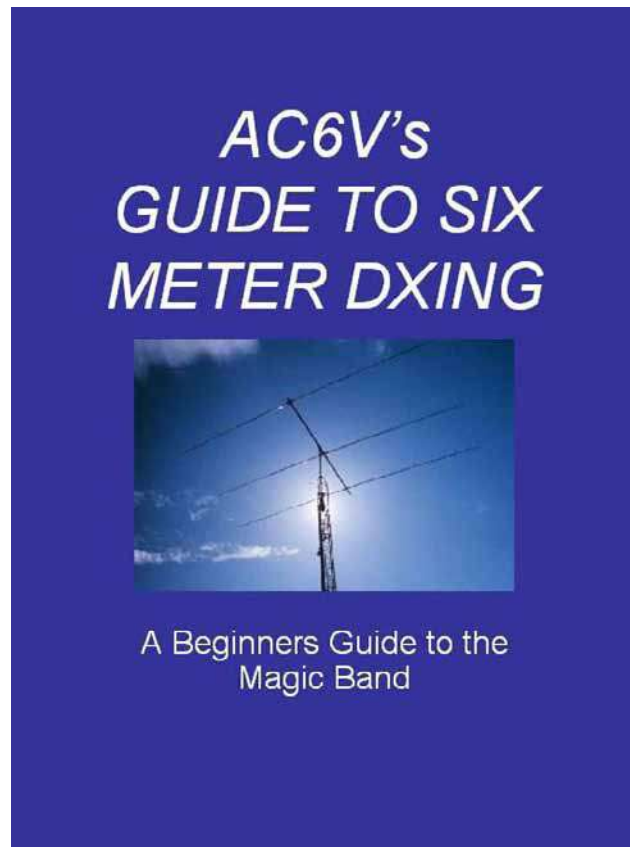

Copyright© 2004 By AC6V Publications
All Rights Reserved AC6V Publications

Price \$19.95 Plus Shipping

Money Back If Not Satisfied

1st Priority Shipping = \$3.85 (USA)

Now Available Book Rate Shipping Boxed =\$2.24 (Allow 2-3 Weeks) (USA)

California Residents, Please Add - 7.75% Sales Tax To Book Price

Not Set Up For Credit Cards - Sorry

USA Orders Payable (Check Or Postal MO) to

Rod Dinkins AC6V

4982 Marin Drive

Oceanside, CA 92056-4973

150 Pages

Deluxe Covers

Book Weighs In At ~10.1 Ounces

Laser Printed On 24 lb Paper, 8-1/2" x 11"

**All Chapter Text In 12 Point Times Roman For EZ Reading
Book Is Copyrighted © With United States Library Of Congress**

(Author Qualifications -- The Brag Tape -- Hewlett-Packard Tech Writer - 21 years, Amateur - 24 years)

✔ **Book is comb-bound so the latest updates will be inserted prior to all orders as we print on demand. This way all updated URL's, reader feedback, and corrections will be in your manual. As further addendums are received, they will be posted here under**

MANUAL UPDATES

CHAPTER 1. INTRODUCTION

| PARAGRAPH & TOPIC | PARAGRAPH & TOPIC |
|--------------------------|--------------------------------|
| 1-2. Using This Guide | 1-6. The Joy Of DXing |
| 1-3. A Little Background | 1-7. The DXer and The Civilian |
| 1-4. The Six Meter Band | 1-8. Awards |
| 1-5. Why DX | |

CHAPTER 2. THE SIX METER BAND PLAN

| PARAGRAPH & TOPIC | PARAGRAPH & TOPIC |
|--|-------------------------------------|
| 2-2. Six Meter Frequency Allotments | 2-5. Tuning In A Nutshell |
| 2-3. USA Recommended Six Meter Band Plan | 2-6. Typical Six Meter Fm Band Plan |
| 2-4. Calling Frequencies | Notes |

CHAPTER 3. DXING EQUIPMENT

| PARAGRAPH & TOPIC | PARAGRAPH & TOPIC |
|---------------------------------|-------------------------|
| 3-2. Transceivers | 3-26. Antenna Height |
| 3-3. Transceiver Specifications | 3-27. Yagi Beams |
| 3-4. Sensitivity | 3-28. Vertical Antennas |
| 3-5. Dynamic range | 3-29. Cubical Quads |
| 3-6. Selectivity | 3-30. Homebrew Antennas |
| 3-7. Superheterodyne Receivers | 3-31. Towers & Rotors |

| | |
|---------------------------------------|---|
| 3-8. Frequency Stability and Accuracy | 3-32. Bearing And Distance |
| 3-9. Cross -Modulation | 3-33. RFI Safety And RFI To The Neighbors |
| 3-10. Gain Compression | 3-34. Lightning Protection And Grounding |
| 3-11. Intermodulation Distortion | 3-35. Computer Equipment |
| 3-12. Phase Noise | 3-36. Coax Cable & Cable Management |
| 3-13. S-Units | 3-37. Voltage Standing Wave Ratio |
| 3-14. Decibels | 3-38. Antenna Tuners |
| 3-15. Transmitter Specifications | 3-39. Microphones |
| 3-16. Duty Cycle | 3-40. Headphones And Speakers |
| 3-17. Whizbang DSP Radios | 3-41. ESP Hearing |
| 3-18. Transceiver Programmability | 3-42. KeysAnd Keyers |
| 3-19. Transceiver Operating Controls | 3-43. DSP Units |
| 3-20. Your Sideband Audio | 3-44. Antenna Analyzers |
| 3-21. Modifications | 3-45. SWR Meters |
| 3-22. Linear Amplifiers | 3-46. Scratch Pads |
| 3-23. Selecting Power Amplifiers | 3-47. Monitor Scopes |
| 3-24. Tubes VS. FETS | 3-48. Foot Switches |
| 3-25. Antennas | 3-49. Other Goodies |

CHAPTER 4. OPERATING AIDS

| PARAGRAPH & TOPIC | PARAGRAPH & TOPIC |
|----------------------------------|-----------------------------------|
| 4-2. Logging Programs | 4-9. Prefix Finder Programs |
| 4-3. Grid Squares | 4-10. Macintosh Programs |
| 4-4. Beacons | 4-11. Propagation Websites |
| 4-5. Distance & Bearing Programs | 4-12. Propagation Software |
| 4-6. Antenna Programs | 4-13. Radio Control Programs |
| 4-7. DXer Programs | 4-14. RTTY, PSK31 & SSTV Programs |
| 4-8. Great Circle Programs | 4-15. Q-Signals & RST |

CHAPTER 5. PROPAGATION

| PARAGRAPH & TOPIC | PARAGRAPH & TOPIC |
|---|--|
| 5-2. The Regions Of The Ionosphere | 5-13. Sporadic E Mapping |
| 5-3. Ionosphere Variations | 5-14. F2 Skip |
| 5-4. Solar Flux, A Index, K Index | 5-15. Beacons |
| 5-5. Six Meter Propagation | 5-16. F2 Backscatter |
| 5-6. Line Of Sight | 5-17. Aurora |
| 5-7. Sporadic E Propagation | 5-18. Trans-Equatorial Propagation. (Tep) |
| 5-8. Sporadic E Seasons | 5-19. Troposcatter |
| 5-9. Hourly Sporadic E Occurrences | 5-20. Ionoscatter |
| 5-10. Sporadic E Geographical Areas | 5-21. Tropo (Tropospheric Bending) |
| 5-11. Sporadic E Solar Cycle Variations | 5-22. Meteor Scatter |
| 5-12. Sporadic E Indicators | 5-23. Propagation Modes Comparison Chart |

CHAPTER 6. WORKING DX

| PARAGRAPH & TOPIC | PARAGRAPH & TOPIC |
|------------------------------|--|
| 6-2. The Big Gun myth | 6-8. CW Operation |
| 6-3. Finding DX | 6-9. DX Packet Clusters and Telnet |
| 6-4. Non-Contest DXing | 6-10. Worked All States |
| 6-5. Working Split | 6-11. Worked 100 Grids Squares (VUCC) |
| 6-6. Working Contests | 6-12. DXCC Awards |
| 6-7. QRP Operation | 6-13. Other Awards |

CHAPTER 7. QSLING

| PARAGRAPH & TOPIC | PARAGRAPH & TOPIC |
|------------------------------|------------------------------|
| 7-2. The QSL Card | 7-15. Envelopes |

| | |
|------------------------------------|---|
| 7-3. Logging | 7-16. Envelope Sizes |
| 7-4. QSL Card Design | 7-17. Return Postage |
| 7-5. Finding QSL Addresses | 7-18. Postage Stamps |
| 7-6. QSLing Domestically | 7-19. Cash |
| 7-7. Sending QSL Cards | 7-20. Bank Checks |
| 7-8. Sending QSLs Direct | 7-21. IRCs |
| 7-9. QSLing Via A DX Manager | 7-22. Monetary Tips For QSL Managers |
| 7-10. Outgoing QSL Bureaus | 7-23. Current US Postal International Rates |
| 7-11. Incoming QSL Bureaus | 7-24. What Is A Good IRC? |
| 7-12. QSLing To A DX Bureau Direct | 7-25. How Much Postage To Send |
| 7-13. QSL Forwarding Services | 7-26. QSL Checklist |
| 7-14. QSLing Electronically | |

Appendices

| APPENDIX/PARAGRAPH & TOPIC | APPENDIX/PARAGRAPH & TOPIC |
|-------------------------------|-------------------------------------|
| A1-1. Learning The Morse Code | A3. DXer Phonetics |
| A1-2. CW Tutorial | A4. Q Signals |
| A1-3. ProsignsFor Morse Code | A5. Grid Square Aids |
| A1-4. Iambic Keying | A6 Six Meter Antenna Projects |
| A1-5. Adjusting Paddles | A7. USA Districts |
| A1-6. CW Abbreviations | A8. Major USA Grid Squares |
| A2. RST System | A9. USA Grid Squares vs. State List |

EMAIL AC6V - CLICK HERE



Updated Tuesday, August 31, 2004

**NOW AVAILABLE
FIFTY HAM RADIO
CROSSWORD PUZZLES
INCLUDING
HUMOR AND QUIZZES**



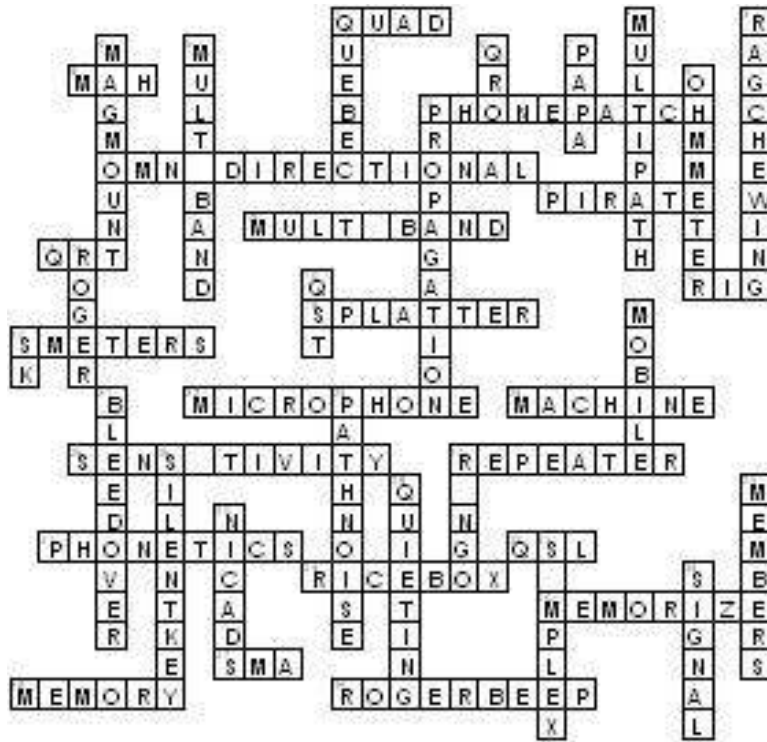

NO! YOU DON'T NEED ANOTHER \$%@* RADIO



Copyright© 2004 By AC6V Publications
 All Rights Reserved AC6V Publications

Price \$9.95 Plus Shipping

Money Back If Not Satisfied

1st Priority Shipping = \$3.85 (USA)

Now Available Book Rate Shipping Boxed =\$2.24 (Allow 2-3 Weeks) (USA)

California Residents, Please Add - 7.75% Sales Tax To Book Price

Not Set Up For Credit Cards - Sorry

USA Orders Payable (Check Or Postal MO) to

**Rod Dinkins AC6V
4982 Marin Drive
Oceanside, CA 92056-4973**

**For Outside Of The USA - Please See [International Calculator](#) For Shipping Costs
Funds By Your Countries "Bank Check" In US Funds Only" - No Personal Checks**

EMAIL AC6V - CLICK HERE



Updated Thursday, August 26, 2004



Check Here If You Want To Open Links In A New Window

HAM RADIO ANTENNAS, COAX, TOWERS, TUNERS & ROTOR MFG

Compiled By AC6V

NOTICE:

The following is a compilation of URLs found on search engines and news groups. The Author makes no endorsement nor has any pecuniary interest in any of the listings. CAVEAT EMPTOR applies as in all things.

▶ [For HomeBrew Antennas](#)

▶ [TOWER RAISING, SPECS, CALCULATORS, AND ADVICE](#)

▶ [HF VERTICAL PERFORMANCE - TEST METHODS & RESULTS](#)

▶ [HF TRIBANDER PERFORMANCE - TEST METHODS & RESULTS - 2nd Edition](#)



BE SURE TO USE CNTRL F To Search This Page - Example "BALUN"

OR

[A](#) [B](#) [C](#) [D](#) [E](#) [F](#) [G](#) [H](#) [I](#) [J](#) [K](#) [L](#) [M](#) [N](#) [O](#) [P](#) [Q](#) [R](#) [S](#) [T](#) [U](#) [V](#) [W](#) [X](#) [Y](#) [Z](#)

[STEALTH ANTENNAS](#)

[MOBILE ANTENNAS](#)

[ANTENNA TUNERS](#)

ANTENNAS, COAX, TOWERS, TUNERS & ROTOR MFG

- [AEA](#) -- Analyzers & Coax Tracer
- [ALF Enterprises](#) -- Larson, Comet, Maxrad, Pryme, Smiley, Wilson, and Antron

- [Alpha Delta Antennas](#)
- [Aluma Tower Company](#) - Crank up towers for Fixed, Mobile and Portable use
- [Amac Automatic Antenna](#) and Rig Control -- For the IC-706 / FT-100 and Screw Driver Antennas
- [Antennas & More](#) - Wayne KC7NMZ -- HF, Mobile, VHF/UHF Antennas
- Antenna Analyzers - See Autek, MFJ & AEA
- [Antenna Specialists](#) -- Mobile Antennas -- Via Universal Radio
- .htm
- [Anti-oxidation products](#) -- NOALOX, PENETROX, more -- Also See [AES Ham Store](#) See On-Line Catalog #14 Page 131-137 or Local Hardware Store -- Also see [Coax-Seal](#)
- [Antron Antennas](#) -- 80 thru 10M Vertical, Hamwhip Single Banders, 10 - 11 Meter Base, VHF/UHF
- [AN Wireless](#) -- Self Supporting Towers
- [Arrow Antennas](#) -- VHF/UHF Antennas includes Satellite Antennas, Yagis, J-Poles, Corner Reflectors
- [ARS antenna rotator](#) control with a computer From EA4TX
- [Atoc Iron Horse HF Mobile](#) -- Via Universal Radio
- [Autek](#) - Antenna Analyzers

-
- [BandHopper](#) -- Mobile/portable/fixed antennas
 - [Barker & Williamson](#) - Antennas, Coils, Accessories for HF Radio
 - [Belden Cable](#) -- go to Products and Services, then Belden Catalog -- in the search box -- type in cable number or 50 (75) ohm coax
 - [Beverage Antenna Transformers](#) - From K1FZ
 - [BlueSky Masts](#) -- Portable Antenna Masts
-- Up to 20 meters
 - [Bozak Antennas](#) - Vhf & UHF Antennas
 - [BuddiPole](#) -- W3FF Products
 - [Butternut Antennas](#) - Via Bencher Pages
 - [BUX CommCo TM®](#) Antennas, Connectors, Parts and Accessories.

-
- [C3I® Antennas](#) - VHF/UHF antennas
 - [Cable Experts](#)
 - [Cable To Go](#)
 - [CAL-AV, INC](#) - Antennas, Baluns, Mobile Antenna Springs, and Morse Keys.
 - [Carolina Cyclone Mobile Antennas](#) - From K4KWH
 - [CB Antennas](#)
 - [Centaur Baluns.com](#)
 - [Champion Radio Products](#) - Professional tower supplies and specialty products
 - [CliffDweller II antenna](#) - Antenna restrictions? - Short on Space? SEE THIS ONE!!
 - [Coax Sealtm](#) -- Hand-moldable, plastic mastic, a waterproof, long-lasting seal for coaxial cable.

- [CobWeb Antenna](#) -- From G3TPW
- [Cojot Antennas](#) - Mobile Antennas
- [Comet Antennas](#) - NCG Companies
- [Comtek](#) - Phased Array Systems, Remote Antenna Switches, Hybrid Phasing Coupler
- [Cubex Quad](#) - SkyMaster Kits
- [CushCraft Antennas](#)
- [CushCraft R5/R7 Vertical](#) Maintenance Tips Schematic Of Black Box.

- [Davis RF Co](#) - Wire, Cable, Dacron Rope Supplier
- [Decibel Products](#) -- Wide Range Of Antennas
- [Degen Designs](#) -- MiniQuad three band, portable, high performance mini-quad antenna
- [Delta X-Ray Antennas](#) - - HF Delta Loops and VHF/UHF ground plane antennas
- [Diamond Antennas](#) - via RF Parts Company
- [N5FC's Notes](#) on the DK9SQ Telescoping Mast
- [DWM Communications](#) -- Yo Yo Wind up Dipole Antenna, Tiny Tenna, Travel Tenna
- [DX Engineering](#) - Boom-to-Mast Plates, Element-to-Boom Plates, Element Clamps, and Harbach Saddle Clamps.
- [DX System Radio](#) - HF thru UHF Antennas

- [EA4TX Antenna Rotator Control Systems](#)
- [Elk Antennas](#) -- log periodic antennas for VHF/UHF
- [EUR-AM](#) -- VHF/UHF Base and Mobile Antennas
- [EZ HANG](#) -- SlingShot & Reel Device for installing wire antennas

- [Ferrite Loop Antenna](#) -- for BC band -- From Oceanstate Electronics
- [Fluid Motion Antennas](#) -- Steppir Antennas
- [Forbes Group](#) -- VENTENNA -- A vent pipe antenna Click Here For [eHam Reviews](#)
- [Ventanna HFP-2 10 Foot HF Antenna](#) -- 6.5 to 30 MHz
- [Force 12 Antennas](#)

- [GB Antennas](#) - From The Netherlands
- [Gem Quad](#) - Cubical Quads
- [GeoTool](#) - Truck Antenna Mount
- [Giovannini Antennas](#) - Italian Site -- D2T Antenna 1.5/200 MHz, 1 KW, Low band DXing Antennas, Broad Band Antennas 1.8/30 MHz 1 KW, Quads, Fiberglass Masts, Rotators
- [Glen Martin Engineering](#) - Towers, Hazer, Telescoping Tower Trailer, Roof-Top Towers, Kevlar Guy Cable & Rope
- [GLA Antennas](#) - Texas BugCatcher
- [Guided Wave Technology](#) -- analyze and design rectangular waveguide filters.

- [HamAntenna](#) -- Canadian Mfg
- [HamStick Antennas](#)
- [Harger Lightning Protection](#)
- [Heights Tower Systems](#)
- [Helitrix™](#) Slinky becomes an antenna
- [Hex-Beam](#) From Traffie Technology
- [Hi-Q Antennas](#) - Mobile
- [Hustler](#) - New-Tronics Antenna Corporation
- [Hybrid Quad Antenna](#) -- From TGM Communications
- [Hy-Gain](#) - By Telex -- New page - Diect Marketing
- [HyperLink Technologies](#) - Antennas, Cable, Accessories
- [Hy Power Antenna Company](#) - Several wire antenna designs
-

- [IIX Equipment Ltd](#) ---- Via W9IIX -- GinPoles, Rotor Mounts, Lots of Tower Accessories

- [K0XG](#) -- Guy Ring Bearings, Ground Mounted Base Rotor, Elevated Base Rotor, Elevated Base Bearing
- [K1CRA Radio Web Store](#) -- RF Connectors, Liquid Tape, Plasti-Dip Products
- [K3IWK](#) -- VHF & UHF Antennas
- [KB6KQ Loop Antennas](#) -- 10 M through 70 cM Stackable Loops
- [K0XG Rotating Tower Equipment](#) -- Guy Ring Bearings, Ground Mounted Base Rotor, Elevated Base Rotor, Elevated Base Bearing
- [KMA Antennas](#) - HF - VHF - UHF Log Periodics & unique 6 meter antennas
- [KVK Antennas](#) -- Vipole, NU-Beam and the multi-band Quad-Folded-Dipole

- [Lakeview Co.](#) -- HamStick Mobile antennas and accessories by WD4BUM
- [Larsen Antennas](#) -- Now a division of Radiall
- [LDG Electronics](#) - Automatic Antenna Tuners
- [Lightning Bolt Antennas](#)
-

- [M2 Antennas](#)
- [Magnetic Loops for HF](#) -- From W2BRI
- [Maldol](#) - VHF/UHF and new Vertical 80/40/30/20/17/15/10/6/2/70cm Via Universal Radio
- [Max Gain Systems](#) - RF coaxial switches, Gin Poles, Antenna Accessories, HF quads
- [MaxRad Antennas](#) -- VHF and UHF Antennas
- [MFJ catalog](#) -- Antennas and Antenna Analyzers
- [MoonRaker Antennas](#) -- UK Manufacturer
- [Mosley HF Beam & Vertical Antennas](#) Mosely Home page
-

- [NILO's Tower Page](#) -- HomeBrew Tower, Guying, Safety, Etc
 - [Nemal Electronics International](#) -- Connectors and Cables
 - [Nil-Jon](#) VHF/UHF Base -- Via Universal Radio
 - [NI8F HF Dipole Antennas](#) -- Via Universal radio
 - [NOALOX](#) -- Anti-Oxidation Product Also See [AES Ham Store](#) See On-Line Catalog #14 Page 131-137 or Local Hardware Store
 - [Norm's Rotor Service](#) -- Sales, Service & Exclusive Exchange Program
 - [NorthWest Antenna](#) -- 2 meters to 160 meters. Compact as well as high power antennas.
-
- [OPAR - the One Person Antenna Raiser](#) -- drive a vehicle on the base for portable operations or mount permanently at your QTH by bolting base to concrete inserts.
 - [OptiBeam](#) -- Now in North America From Array Solutions
 - [Outbacker Antennas](#) -- Terlin
-
- [PalStar](#) - Tuners and accessories, SW radio, Dummy loads, SWR Meters, Filters
 - [Par End-Fedz](#) -- full length half wave dipoles, but with an important difference. The coax connector is at one end of the dipole, where it is most needed. From Universal Radio
 - [Par Omniangle Antennas](#) -- 10M/6M/VHF/UHF - Also available From [Universal Radio](#)
 - [PCE International](#) -- Towers and Antennas
 - [PENETROX](#) -- Anti-oxidation product Also See [AES Ham Store](#) See On-Line Catalog #14 Page 131-137 or Local Hardware Store
 - [PolyPhaser Corp.](#) - Lightning Protection Devices
 -
-
- [Quicksilver Radio Products MinuteMan™ HF Portable Antennas](#)
 -
-
- [Radio Shack](#)
 - [RadioWare](#) -- HF Mobile, VHF/UHF Mobile, Yagis, Omnidirectional
 - [Radio Warehouse](#) - distributor of Coax and Wire products to the Amateur Radio Market.
 - [Radio Waves](#) -- Microwave Antennas
 - [Radio Works](#) -- CAROLINA Windom/Beam, SuperLoop, Isolators, Baluns
 - [Raibeam Antennas International](#) -- A Wide Variety of Beam Antennas
 - [R.F. Connection](#) -- Specialist in RF Connectors and Coax
 - [Rohn and Unr-Rohn](#) - Towers and Other Products
 - [Rotor Service](#) - Norm's
-
- [The ScrewDriver.Com](#) -- High quality full legal limit with mount and digital controller at an affordable price.
 - [SETI Antennas](#) -- From The SETI League
 - [SGC World](#) -- Smarttuner & Antennas

- [Shakespeare Antennas](#) -- Composite Marine Antennas
 - [Sinclair Technologies](#) -- Base/mobile antennas, duplexers, cavity filters
 - [Smiley Antennas](#)
 - [Solarcon A99](#) - Via Universal Radio
 - [Solarcon IMAX 2000](#) Base Antenna -- a 5/8 version of the A99
 - [Solder-It](#) -- All Kinds Of Solder Products
 - [Sommer Antennas](#)
 - [Spider Antennas](#) -- From Multi-Band Antennas
 - [SpiRo's MultiBand Antennas](#)
 - [SSB Electronics](#) -- Big Wheel Antennas 2M & 70cm
 - [Stealth Antennas](#) -- HF Mobile Antennas By VE7BOC
 - [Steppir Antennas](#) -- Fluid Motion
 - Stuf -- Dielectric Water-Proof Connector Filler - See [AES Ham Store](#) See #14 Page 131-137 or Local Hardware Store
 - [Super Antennas](#) - Vern Wright's HF Mobile Antennas, MP1 etc.
-

- [T-Hunting Equipment](#)
 - [TarHeel Mobile Antennas](#)
 - [Telewave](#) -- Combiners, MultiCouplers, cavities
 - [Telex](#) -- Hy-Gain Products
 - [Tennadyne Corp](#) -- Log Periodics
 - [Texas BugCatcher And Texas Twister](#)- GLA Antennas
 - [Texas Towers](#)
 - [T.G.M. Communications](#) -- Mini-Quads
 - [Thrust Bearing FAQ](#) -- From The YCCC
 - [Times Microwave Systems](#) -- Coax and Connectors
 - [Titanex Antennas](#)
 - [Top Ten Devices, Inc](#) - Data decoders and antenna switching
 - [Traffie Technologies](#) -- Hex Beams
 - [Trasel Technologies.](#) -- Antenna Mounts, Thread Mounts, HF and VHF/UHF Antennas
 - [Trilogy Communications](#) -- High Grade Cable
 - [Trival Antennas](#) -- From Slovenia
-

- [Unadilla Antenna Mfg Co.](#) -- Baluns, Traps, Coaxial Relays, Insulators, Wire
 - [Universal Radio](#) -- Large Selection of Antennas, Towers, Rotors, Tuners, Switches, Coax
 - [US Tower](#)
-

- [Valcom](#) -- Fibreglass Whip Antennas
- [Valor](#) VHF/UHF Antennas -- Via Universal Radio

- [Vectronics](#) -- Tuners, Filters, Dummy Loads, Keyers, Wattmeters
 - [VENTENNA](#) -- A VHF/UHF vent pipe antenna -- Click Here For [eHam Reviews](#)
 - [Ventanna HFP-2 10 Foot HF Antenna](#) -- 6.5 to 30 MHz
-

- [W3FF](#) Antennas -- [Buddipole™](#), the new [Buddistick™](#) for HF Portable operations.
 - [W7FG](#) - Ladder Line and Antennas. 600 Ohms. Doublets and G5RV antennas
 - [WB0W, Inc](#) - Antennas, Towers, Hazers, more
 - [Wellbrook Communications](#) -- Antenna Loops for MEDIUM WAVE, LONG WAVE & SHORT WAVE

 - [WideBand Loop Antenna](#) -- From Maarten Haag
 - [Wilderness Radio](#) - For the outdoor QRP enthusiast
 - [Wilson Antennas](#)
 - [WireMan Inc](#) -- Wires, Coax, Baluns A Bunch
 - [WorldRadio](#) -- SD-20 Antenna Support extends from 47 inches to 20 feet. It weighs less than 2 pounds. Go to Products.
 - [W5AJ Tower Raising](#)
 - [WX0B](#) -- [StackMatch](#) - for stacking, phasing, and switching antennas
-
- [XXTowers](#) -- Experts in amateur radio installations of all types and sizes.
-

Antenna Tuners

[Alinco Electronics](#)

[Alpha Delta](#)

[Ameritron](#)

[Elecraft](#)

[ICOM](#)

[Kenwood](#)

[LDG Electronics](#)

[MFJ Enterprises, Inc.](#)

[PalStar](#)

[SGC, Inc.](#)

[Ten-Tec](#)

[Vectronics](#)

[Yaesu](#)

- **Mobile Antenna Manufacturers**
-
- [FAQ ON GLASS MOUNT ANTENNAS & GENERAL INSTALLATION INFO](#)
-
- [MOBILE ANTENNA SHOOTOUT TEST RESULTS](#)
- [AntenneX](#)
- [Antenna Specialists](#)
- [BandHopper](#)
- [Carolina Cyclone Mobile Antennas](#) - From K4KWH
- [Comet/NCG](#)
- [Diamond MV3A Mobile Antenna System](#)
- [DK3 Screwdriver](#) - N7LYY
- [GS Manufacturing Mobile Antennas](#)
- [HamStick Antennas](#)
- [Hi-Q Antennas](#)
- [High Sierra Antennas](#)
- [Hustler Antennas](#)
- [K4POZ Mobile Antennas](#)
- [Lakeview](#) - Hamsticks
- [Larsen Antennas](#)
- [New-Tronics \(Hustler\)](#)
- [RadioWare](#)
- [The ScrewDriver.Com](#) -- High quality full legal limit with mount and digital controller at an affordable price.
- [Spider Antennas](#)
- [Super Antennas](#) - W6MMA
- [Tarheal Antennas](#)
- [Terlin Outbacker](#)
- [Texas BugCatcher](#)

COMMERCIAL ANTENNAS USED FOR STEALTH

[ABOUT CC&R's AND RESTRICTIONS](#)

[BuddiPole](#) -- W3FF Products

[B&W Balcony/Window Antenna](#) - AP-10A

[CliffDweller II antenna](#)

[End-Fedz](#) -- full length half wave dipoles, but with an important difference. The coax connector is at one end of the dipole, where it is most needed. From Universal Radio

[EZ HANG](#) -- SlingShot & Reel Device for installing wire antennas

[Force 12- 9 Foot Vertical](#)

[Force 12 Aluminum Flag Poles & Antennas](#)

[HamSticks](#)

[High Sierra Antennas](#) - Mobile HF antennas, New El Dorado for Restricted Locations

[Isotron Antennas](#)

[MFJ Apartment Antenna](#) 40 Meters to 2 Meters MFJ-1622

[MFJ Super Loop Antennas](#)

[Outbacker Antennas](#) -- Terlin

[Quicksilver Radio Products MinuteMan™ HF Portable Antennas](#)

[The ScrewDriver.Com](#) -- High quality full legal limit with mount and digital controller at an affordable price.

[Stealth Antennas](#) -- HF Mobile Antennas By VE7BOC

[Texas BugCatcher](#) - GLA Antennas

[Texas Twister](#) - GLA Antennas

[Ventennas](#) -- The Forbes Group

[Ventanna HFP-2](#) 10 Foot HF Antenna -- 6.5 to 30 MHz !!!

[Vern Wright's HF Mobile Antennas, MP1](#)

[WeatherVane Antennas](#)



Selected Antenna Books



[It Is Back In Print -- Ed Knoll's "Easy Up Antennas" - A good One](#)



[New From Ed Knoll "Dipole and Long Wire Antennas"](#)



The Arrl Antenna Book

[Buy the Book Today!](#)



[The Radio Amateur Antenna Handbook By William I. Orr](#)

[Buy the Book Today!](#)



[Cubical Quad Antennas : How to Build and Adjust Quads -- by William I. Orr, Stuart D. Cowan](#)

[Buy the Book Today!](#)



[Lew McCoy on Antennas](#)

[Buy the Book Today!](#)



[Beverage and Longwire Antennas Design and Theory -- by Chuck Hutton](#)

[Buy the Book Today!](#)



[ON4UN's Low Band DXing -- by John Devoldere -- Great Source For Low band Antennas](#)

[Buy the Book Today!](#)

OVER 300 ANTENNA BOOKS FROM AMAZON.COM
SELECT Books then TYPE Antenna in the KEYWORD BOX

| | |
|---|-------------------|
| Search: | Enter keywords... |
|  | |



[HomeBrew Ur Antenna?? -- Visit The AC6V Antenna Homebrew Links](#)



[Antenna & Tower Mail Lists -- Subscription Info](#)



[Coax Cable Charts With Losses, Power Ratings, etc](#)



[Antenna Software -- Visit The AC6V Antenna Software Links](#)



[Antennex -- The Ham Antenna Magazine -- all about antennas -- on line](#)



[Tower Talk Mail List Reflector -- Subscription Info](#)

CAN'T FIND THE DEALER OR VENDOR? TRY THESE.

[BACK TO THE MASTER DEALER PAGE](#)

- [TIS FIND](#) -- From The ARRL

AC6V's

Amateur Radio Links

[GO BACK TO THE BIG INDEX](#)

AC6V's

Amateur Radio Links

[GO BACK TO THE QUICK INDEX](#)



[AC6V BRAG TAPE](#)



Lsst Update: September 02, 2004



Open links in a new window



SHORTWAVE, LONGWAVE, DC TO DAYLIGHT

**NOTE: THE SUBJECT OF SWL IS TOO LARGE TO COVER ON ONE PAGE
THUS PAGES ARE SET UP AS FOLLOWS:**

[This Page -- see Table Below](#)
[Great SWL Frequency Listings](#)
[Great SWL Pages and Links](#)
[Frequency Band Plans](#)
[Spectrum Chart -- See This One](#)

Quick Click



THE GATEWAY TO DC TO DAYLIGHT
 Click On Your Topic

| | | |
|---|---|--|
| <u>AM, FM & TV Stations</u> | <u>Frequency Listings, SWL</u> | <u>QSLing SW Stations</u> |
| <u>Amateur Radio Listening</u> | <u>Logging Prog - General & Ham</u> | <u>Radio History</u> |
| <u>Antennas & Grounding</u> | <u>Logging Programs SWL</u> | <u>Receiver Reviews</u> |
| <u>Bands, SWL</u> | <u>LongWave</u> | <u>Scanners</u> |
| <u>Books -- SWL & Scanner</u> | <u>Manuals, Radio</u> | <u>Shortwave Web Pages</u> |
| <u>Books -- AC6V Book Store</u> | <u>Modulation Modes</u> | <u>Software, SWL</u> |
| <u>Citizens Band</u> | <u>Propagation Software</u> | <u>SWLing The Ham Bands</u> |
| <u>Dealers & Mfg's, SWL</u> | <u>QSL Forms and QSL Cards</u> | <u>Technical Info For SWLers</u> |
| <u>FAQ's, SWL</u> | | <u>Web Controlled Radios</u> |

**TO SEARCH THE PAGE
USE YOUR BROWSER FIND COMMAND
OR USE CNTRL F**



BOOKS FOR SHORT WAVE LISTENERS

Buy Your Books Thru The AC6V Book Store

RADIOS FOR SHORT WAVE LISTENERS

Buy Your Radios Thru The AC6V Book Store



[Easy-Up Antennas For SWL and Hams -- Back In print By Edward Noll -- SEE THIS ONE](#)



[Fifty Ways to Improve Your Short Wave Listening From DWM Communications](#)



[SCANNER BOOKS](#)

[Radios and Reception - Testing and Tips From Philly Talk Radio Online](#)

[SWL Receiver Reviews -- From Radio Netherlands](#)

[What You Need to Hear Shortwave Stations -- Receivers and Antennas](#)

[Short Wave Receiver Reviews -- From eHam.net -- Over 71 Short Wave Receivers](#)

[Shortwave Receivers Survey --- Specs, Features and Comprehensive Reviews](#)

[Shortwave Receiver Reviews From Strong Signals Resource Page](#)

[Shortwave Receiver Reviews -- Via RadioIntel.com](#)

[Shortwave Receivers Review -- From Durham Radio](#)

[Modern Shortwave Receivers Survey -- From DXing.com](#)

[Selecting A Shortwave Receiver -- From DXing.com](#)

[Super heterodyne Receiver Theory -- includes Sensitivity, Dynamic Range, more](#)

[ICOM PCR 1000 Resource Page -- Test Drive & PCR Frequency Files](#)

[Yaesu FRG-7 Information](#)

[Sangean ATS-909 Review - From Radio Netherlands](#)

[Synchronous Demodulation --- What is it and how it works](#)

SWL SOFTWARE



[Propagation Software Is At The Propagation Pages](#)

[Radio Explorer](#) -- By Dmitry Nefedov -- Graphic viewer for shortwave schedules (ILGRadio and HFCC), displaying data in a tree-like way and on a Gantt.chart. It also features a world map with greyline and MUF coloring. It is developed in Java and runs on multiple platforms.

[Radio Listener's Database](#) integrating the power of the top five broadcast databases available today

LOGGING PROGRAMS

[ShortWave Log \(SWLog\)](#) -- Logging and Radio Control for SWLing

[B-Log Version 1.1](#) -- From AB9B

[WRLog v1.10](#) -- From Paraclete InfoSys

[**DXtreme™**](#) produces powerful and easy-to-use logging applications for radio enthusiasts such as: **Shortwave DXers and Listeners**

[**GenLog**](#) --- contests and as a general logger and SWL also.

[**WLOG2000 LogBook for OM SWL BCL CB**](#) -- Database logbook for OM SWL BCL & CB with utility like **DXCLuster DXtelnet PSK PSK-Pbbs** (TNC or PC sound card) radio rotor **CDbook** interface and many other features. Free Update at homepage.

[**SWLTool \(Version 1.4.5\)**](#) ... a utility to read and display **ILG** radio data files

[**Many More Ham Logging Programs**](#) which you might use for SWL Logging.



SWL ANTENNAS

[**ALSO SEE SWL DEALERS**](#)

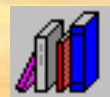

[**Easy-Up Antennas For SWL and Hams**](#) -- Back In print By Edward Noll -- **SEE THIS ONE**

[**Amandx Antenna Pages**](#)

[**AM Antennas**](#) -- by Bruce Carter

[**AM Loop Antennas**](#)

[**Antenna Advice**](#) -- From Radio Netherlands

[**Antennas A Bunch**](#) -- From Hard-Core-DX

[**Antenna Basics and Theory**](#) -- From Ian C. Purdie, VK2TIP

[**Antenna Basics and Theory**](#) -- Excellent Tutorial From Scott's Pages

[**Antenna Basics and Theory**](#) -- Excellent From Integrated Publishing

[**Antenna Basics and Theory**](#) -- From Sub-TV

[**Antenna Dimension Calculators**](#) -- From The Antenna Elmer - Click On Antenna Type

[**Antenna Dimension Calculators**](#) -- Inverted Vee And Dipoles

[**Antenna Dimensions Calculator Dipoles**](#)-- From AMANDX

[**Antenna Gain**](#) -- From L. B. Cebik

[**Antennas - Low Noise**](#), Grounds for low noise, longwire impedance matching

[**Antenna Loops**](#) -- From Wellbrook Communications

[**Antennas, SWL**](#) -- Wire, Loops, Invisible, Feeding, Grounding, Many More From HCDX

[Antennas For SWLs --- From K6QGH](#)

[Antenna testing and reviews -- From Philly Talk Radio Online](#)

[Antenna Tuner Theory -- From The ARRL](#)

[Beverage Antennas](#)

[Broomstick Special](#) [The Broomstick Special, Part 2](#)

[Choosing Wire For An Antenna](#)

[Dipole & Inverted Vees Antennas](#)

[Doug's Antenna Transformer Page](#)

[DWM Communications -- Yo Yo Wind up Dipole Antenna, Tiny Tenna, Travel Tenna](#)

[Feed Lines For Antennas -- From HCDX](#)

[Frankenstein Monster Antenna -- From Michael's SW and DXing Page](#)

[G5RV Antenna For Shortwave -- From Michael's SW and DXing Page](#)

[Great White North Antenna](#)

[Grounding -- For Safety and For Noise Reduction](#)

[Grounding is key to good reception](#)

[Height Of Dipoles - Patterns By AA3RL](#)

[ICE180 Matching Unit -- From HCDX](#)

[Impedance Transformers for Receiving Antennas -- John Bryant](#)

[Inverted L Antenna -- From ARNIE CORO \(CO2KK\)](#)

[K9AY Directional Terminated Loop Antenna](#)

[Long Wire Antennas -- Via AMANDX](#)

[Loop Antennas -- Discussion Group - from Yahoo Forums](#)

[Loops for AM BC Band - From Dave's Antenna Loop page](#)

[Low Noise Antenna Connection -- Via Boston Area DXers](#)

[PAR High-Performance Shortwave Antenna](#) [HF End Fed SWL antenna](#)

[Random Wire Antenna and Improved Random Wire Antenna -- From CW's Radio Pages](#)

[T2FD Terminated Tilted Folded Dipole](#)

[Tuned Loop AM Broadcast Antenna -- From VK2ZAY](#)

[WellBrook Loop Antennas](#)

[WideBand Loop Antenna -- From Maarten Haag](#)

[Commercial SWL Antennas I -- From Universal Radio](#)

[Commercial SWL Antenna II -- From Alpha Delta](#)

[SWL FORUM -- FROM YAHOO](#)

[**DXing.Com**](#) -- All about SWLing and DXing -- From Universal Radio

[**FAQ'S ABOUT SHORTWAVE RADIO**](#) --From National Association of Shortwave Broadcasters, Inc.

[**Shortwave Radio Information**](#) -- for Beginners by Lou Castino

[**SWLing The Ham Bands**](#)

[**Digital Signals FAQ**](#) -- Loaded -- From WUN

[**Radio H.F. Catalogue & Newsletter**](#) -- By Sheldon Harvey

[**Short Wave Amateur Radio Listening**](#)

MODULATION AND MODES

[**How Modulation Modes Work**](#) -- Very Visual Explanations for AM, FM, SSB, DSB, QAM

[**Modulation Codes**](#) --- AJE, A1A, Etc

[**Modes & Modulation**](#) -- CW, AM, SSB, USB, LSB, FM, FSK, AMTOR, FEC, PACKET, Spread Spectrum -- From DXing.com

All About SSB, DSB, ECSS, more -- [**History Of SSB**](#) By DJ4BR Peter Weber

[**Modulation Schemes**](#) --- AM, FM, Pulse Technical Discussions

[**ALSO SEE OPERATING MODES**](#) -- AMTOR, APRS, ATV, CLOVER, CW, Digital, EME, SETI, Astronomy, FAX, GMRS, GPS, GTOR, Laser, Low Freq, Meteor Scatter, Microwave, NAVTEX, PACKET, PACTOR, PSK31, QRP, RTTY, Satellites, Spread Spectrum, SSTV, T-Hunts, WEFAX

QSLING SW STATIONS, SAMPLE QSL FORMS AND CARDS, QSL

GALLERIES

[SWL QSL CARDS FROM CHEAP QSL's.COM](#)

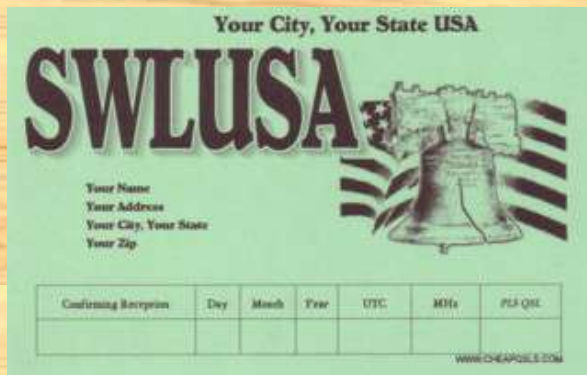

[All About Reporting and QSLing -- Via DXing.com](#)

[Reporting and QSL - Via Amandx](#)

[A realistic guide to reception report writing in the new millennium -- From Radio Netherlands](#)

[Reporting Codes --- SIO and SINPO -- From Radio Netherlands](#)

[QSL Form --- From China Radio International/Shortwave](#)

[QSL Form --- From K6QGH](#)

[SWL QSL Card Museum -- Wow -- Loaded A massive collection of SWL QSL cards from around the world](#)

[Get Ur Own SWL Callsign](#)



GENERAL FREQUENCY LISTINGS

[FREQUENCY BAND PLANS -- FOR ALL KINDS OF SERVICES Click Here](#)

SWL FREQUENCY LISTINGS

| | |
|------|------|
| BAND | BAND |
|------|------|

| | |
|-----------------------------|--------------------------------|
| 120 m ____ 2300 -- 2495 kHz | 25 m ____ 11.500 -- 12.160 MHz |
| 90 m ____ 3200 -- 3400 kHz | 22 m ____ 13.570 -- 13.870 MHz |
| 75 m ____ 3900 -- 4000 kHz | 19 m ____ 15.030 -- 15.800 MHz |
| 60 m ____ 4750 -- 5060 kHz | 17m ____ 17.480 -- 17.900 MHz |
| 49 m ____ 5730 -- 6295 kHz | 16m ____ 18.900 -- 19.020 MHz |
| 41m ____ 6890 -- 6990 kHz | 13 m ____ 21.450 -- 21.750 MHz |
| 41 m ____ 7100 -- 7600 kHz | 11 m ____ 25.670 -- 26.100 MHz |
| 31 m ____ 9250 -- 9990 kHz | |

The "Radio Regulations" of the International Telecommunications Union define the shortwave broadcast bands. At the 1992 World Administrative Radio Conference, new bands were created and existing bands were expanded. The band limits in the following table reflect the WARC-92 agreements and broadcast band expansions used on a non-interfering basis (e.g., the 41 m band starting at 6890 kHz on a non-interference basis): Although the allocations do not become official until 2007, in practice many stations have already started using the expanded portions under the motto "use it or lose it." Additionally, there are a few stations that broadcast outside the band edges above, e.g., Iran on 9022 and a number of African stations around 9200 kHz. Clearly, receivers with continuous coverage between 1.6 and 30 MHz are preferred.

[FREQUENCY LISTINGS WORLD WIDE -- HUNDREDS - Click Here](#)



GREAT SWL FREQUENCY LISTINGS

[FROM MONITORING TIMES](#)

[Listner Laws](#)

[Airshow Frequency List](#)

[Monitoring NASA Communications \(Space Shuttle et al\)](#)

[Hot 1000 HF Frequencies](#)

[Monitoring Times Frequency Exchange](#)

[Monitoring Times Frequency Reference Library](#)

[Comprehensive Shortwave Broadcasting Schedule By Eike Bierwirth, Leipzig, Germany](#)

[ID, Interval signals, signature tunes, and identification announcements from international, domestic, and clandestine radio stations around the world](#)

[SWL Stations](#) that are scheduled to broadcast in English at the moment you request the page.

[SWL Stations](#) -- enter a frequency, and see all those who are scheduled to use that frequency.

[SWL Stations](#) -- By Time Or Country -- From PrimeTime ShortWave

[Optimal Frequencies By Time For This Month](#)

[Hot 100 SWL Stations](#) -- From ICOM America

[International Broadcasters on Short-wave Radio](#) -- From Steve R. Adams

[Top 1000 HF SWL Frequencies](#) -- From Monitoring Times

[Hundreds Of SWL Stations Transmitting In English to The USA](#)

[NASWA Shortwave Loggings](#) -- Loaded

[Prime Time Short Wave](#) -- Your guide for English shortwave broadcast schedules

[Also See Great SWL Web Pages](#)

AM, FM & TV STATIONS

[50KW AM Night Stations -- USA With Canada and Mexico Listings](#)

[Finding AM/FM Stations Near You \(USA & World Wide\)](#)

[FCCINFO Search -- Find AM, FM, TV Stations in the USA](#)

[FCC Data Base - Several search options available](#)

[Medium Wave Radio -- From Radio Netherlands](#)

[AM Broadcast Station Locator -- From The FCC](#)

[FM Broadcast Station Locator -- From The FCC](#)

[TV Broadcast Station Locator -- From The FCC](#)

[TV DXing -- From Jeff Kadet](#)

[Travelers AM Locator -- From The FCC](#)

[FM and NTSC TV Propagation Curves Calculation -- From The FCC](#)

[For Broadcast Professionals -- Quick Access to Related Links. -- From Radio 411](#)

[U.S. AM Radio Stations Radio-Locator -- \(Formerly known as "The MIT List of Radio Stations on the Internet"\)](#)

[AM or FM Data Base -- From Elliott Broadcast Services](#)

[TvRadioWorld -- Internet Broadcast Directory and Radio/Television Stations Web Listings](#)

[Radio History -- 16 Top Pages Of Radio History](#)



SCANNERS



BOOKS FOR SCANNER ENTHUSIASTS



Scanners & Secret Frequencies (Electronic Underground Series, Vol 3) by Henry L. Eisenson

[Buy the Book Today!](#)

SCANNER WEB PAGES & FREQUENCIES

FROM MONITORING TIMES

[Listner Laws](#)

[Airshow Frequency List](#)

[Monitoring NASA Communications \(Space Shuttle et al\)](#)

[Hot 1000 HF Frequencies](#)

[Monitoring Times Frequency Exchange](#)

[Monitoring Times Frequency Reference Library](#)

[FCC Data Base - Several search options available](#)

-- Check Em Out

[Introduction to Scanning](#) -- by Bob Parnass, AJ9S -- If you own a Scanner -- these are a **MUST READ**

[PerCon Data Finder](#) -- Exhaustive online source of frequencies

[Police Calls](#) -- Visit Radio Shack for "Police Call" series of books

[Selecting A Scanner](#) -- From DXing.com

[Scanner Users FAQ](#) -- From Rich Wells N2MCA

[Scanners Reference Guide](#) -- By Clay Irving N2VKG

[10-Codes](#) -- Police, Fire, etc Usage

AC6V's

Amateur Radio Links

[GO BACK TO THE BIG INDEX](#)

AC6V's

Amateur Radio Links

[GO BACK TO THE QUICK INDEX](#)



AC6V BRAG TAPE



This Page Last Updated:September 03, 2004_



Check Here If You Want To Open Links In A New Window

Antenna Software

Compiled By AC6V

NOTICE:

The following is a compilation of URLs found on search engines and news groups. The Author makes no endorsement nor has any pecuniary interest in any of the listings.

CAVEAT EMPTOR applies as in all things.

- ◆ [Antenna Design Freeware](#) -- 1D and 2D arrays from MEI Software
- ◆ [Antenna Designing Software](#)
- ◆ [Antenna Feed System](#) Modeling Software by Dan Maguire, AC6LA -- includes Smith chart tutorial
- ◆ [Antenna Shareware A Bunch](#) -- See Goldmine Software one thru five -- not to be missed!!
- ◆ [Antenna Software A Ton](#) -- From The Spread Spectrum Scene -- Not to be missed!!
- ◆ [Antena Solver -by Dr. David Fluckiger, KJ5AT](#)
- ◆ [Antenna Software](#)
- ◆ [Antenna Design and Software](#) From G4FGQ -- Loaded -- many antenna design programs, coax rating, ferrites and toroids, Groundwave propagation, much much more.
- ◆ [Antenna Software -- Loaded](#) -- Via OK1RR
- ◆ [Antenna Software by W7EL](#) -- EZNEC, EZNEC pro, ELNEC
- ◆ [Antenna Software From QRZ](#)

- ◆ [Cubical Quad Antenna Calculator](#) -- From KD6DKS
- ◆ [EMMCAP Software](#) for modeling of arbitrarily shaped wire structures and the computation of their electromagnetic behavior, including radiation and scattering problems.
- ◆ [EZNEC 3.0](#) -- For for Windows 95/98/NT/200
- [Grating Solver Development Company](#) - Antenna Solver V1.1a and GSOLVER© V4.20a
Highly recommended by a local antenna guru.
- ◆ [Mac Antenna Master](#) -- From Black Cat Systems
- ◆ [The MININEC Professional Series](#)
- NEW** [MMANA](#) (MM Antenna Analyzer) BY JE3HHT - Makoto Mori
- ◆ [MultiNEC 2.0](#) -- -- Automate and animate your antenna modeling and propagation predictions -- From AC6LA
- ◆ [NEC4WIN®](#) -- Antenna Simulation Software for Windows © NecView® Windows© interface for NEC2 From VE2GMI Madjid Boukri
- ◆ [Nittany Scientific, Inc.](#) -- Antenna Analysis with the User in Mind
- ◆ [PolarPlot](#) -- Polar diagram of your rotatable beam antenna actually looks like where it is operating. From Bob, G4HFQ
- ◆ [Power Loss/ dB Calculator](#) by W4SM
- ◆ [RF Calculator Page](#) From WA7CS -- Over 40 Programs to help with RF design and antennas
- ◆ [YagiStress](#) -- The Ultimate Mechanical Design Software For Antenna Designers. -- By Kurt Andress, NI6W

 [YAGIMAX](#)

 [YTAD](#) -- by N6BV -- Determine antenna gain based on the slope of terrain

 [Quick Yagi](#) -- Via WA7RAI's Home Page -- yagi auto-design, auto-optimize, modeling software

 [Commercial Antennas](#) -- Visit AC6V's Antenna Mfgs Links

 [HomeBrew Antennas](#) -- Visit AC6V's Antenna Project Links

[AC6V's](#)
Amateur Radio Links [GO BACK TO THE BIG INDEX](#)

[AC6V's](#)
Amateur Radio Links [GO BACK TO THE QUICK INDEX](#)

 AC6V BRAG TAPE



Last Updated: August 21, 2004



**NONRESIDENT
TRAINING
COURSE**

SEPTEMBER 1998



Navy Electricity and Electronics Training Series

Module 10—Introduction to Wave Propagation, Transmission Lines, and Antennas

NAVEDTRA 14182

Although the words “he,” “him,” and “his” are used sparingly in this course to enhance communication, they are not intended to be gender driven or to affront or discriminate against anyone.

PREFACE

By enrolling in this self-study course, you have demonstrated a desire to improve yourself and the Navy. Remember, however, this self-study course is only one part of the total Navy training program. Practical experience, schools, selected reading, and your desire to succeed are also necessary to successfully round out a fully meaningful training program.

COURSE OVERVIEW: To introduce the student to the subject of Wave Propagation, Transmission Lines, and Antennas who needs such a background in accomplishing daily work and/or in preparing for further study.

THE COURSE: This self-study course is organized into subject matter areas, each containing learning objectives to help you determine what you should learn along with text and illustrations to help you understand the information. The subject matter reflects day-to-day requirements and experiences of personnel in the rating or skill area. It also reflects guidance provided by Enlisted Community Managers (ECMs) and other senior personnel, technical references, instructions, etc., and either the occupational or naval standards, which are listed in the *Manual of Navy Enlisted Manpower Personnel Classifications and Occupational Standards*, NAVPERS 18068.

THE QUESTIONS: The questions that appear in this course are designed to help you understand the material in the text.

VALUE: In completing this course, you will improve your military and professional knowledge. Importantly, it can also help you study for the Navy-wide advancement in rate examination. If you are studying and discover a reference in the text to another publication for further information, look it up.

*1998 Edition Prepared by
FCC(SW) R. Stephen Howard and CWO3 Harvey D. Vaughan*

Published by
NAVAL EDUCATION AND TRAINING
PROFESSIONAL DEVELOPMENT
AND TECHNOLOGY CENTER

**NAVSUP Logistics Tracking Number
0504-LP-026-8350**

Sailor's Creed

“I am a United States Sailor.

I will support and defend the Constitution of the United States of America and I will obey the orders of those appointed over me.

I represent the fighting spirit of the Navy and those who have gone before me to defend freedom and democracy around the world.

I proudly serve my country's Navy combat team with honor, courage and commitment.

I am committed to excellence and the fair treatment of all.”

TABLE OF CONTENTS

| CHAPTER | PAGE |
|---|-------------|
| 1. Wave Propagation | 1-1 |
| 2. Radio Wave Propagation | 2-1 |
| 3. Principles of Transmission Lines | 3-1 |
| 4. Antennas | 4-1 |
| APPENDIX | |
| I. Glossary | AI-1 |
| INDEX | INDEX-1 |

NAVY ELECTRICITY AND ELECTRONICS TRAINING SERIES

The Navy Electricity and Electronics Training Series (NEETS) was developed for use by personnel in many electrical- and electronic-related Navy ratings. Written by, and with the advice of, senior technicians in these ratings, this series provides beginners with fundamental electrical and electronic concepts through self-study. The presentation of this series is not oriented to any specific rating structure, but is divided into modules containing related information organized into traditional paths of instruction.

The series is designed to give small amounts of information that can be easily digested before advancing further into the more complex material. For a student just becoming acquainted with electricity or electronics, it is highly recommended that the modules be studied in their suggested sequence. While there is a listing of NEETS by module title, the following brief descriptions give a quick overview of how the individual modules flow together.

Module 1, *Introduction to Matter, Energy, and Direct Current*, introduces the course with a short history of electricity and electronics and proceeds into the characteristics of matter, energy, and direct current (dc). It also describes some of the general safety precautions and first-aid procedures that should be common knowledge for a person working in the field of electricity. Related safety hints are located throughout the rest of the series, as well.

Module 2, *Introduction to Alternating Current and Transformers*, is an introduction to alternating current (ac) and transformers, including basic ac theory and fundamentals of electromagnetism, inductance, capacitance, impedance, and transformers.

Module 3, *Introduction to Circuit Protection, Control, and Measurement*, encompasses circuit breakers, fuses, and current limiters used in circuit protection, as well as the theory and use of meters as electrical measuring devices.

Module 4, *Introduction to Electrical Conductors, Wiring Techniques, and Schematic Reading*, presents conductor usage, insulation used as wire covering, splicing, termination of wiring, soldering, and reading electrical wiring diagrams.

Module 5, *Introduction to Generators and Motors*, is an introduction to generators and motors, and covers the uses of ac and dc generators and motors in the conversion of electrical and mechanical energies.

Module 6, *Introduction to Electronic Emission, Tubes, and Power Supplies*, ties the first five modules together in an introduction to vacuum tubes and vacuum-tube power supplies.

Module 7, *Introduction to Solid-State Devices and Power Supplies*, is similar to module 6, but it is in reference to solid-state devices.

Module 8, *Introduction to Amplifiers*, covers amplifiers.

Module 9, *Introduction to Wave-Generation and Wave-Shaping Circuits*, discusses wave generation and wave-shaping circuits.

Module 10, *Introduction to Wave Propagation, Transmission Lines, and Antennas*, presents the characteristics of wave propagation, transmission lines, and antennas.

Module 11, *Microwave Principles*, explains microwave oscillators, amplifiers, and waveguides.

Module 12, *Modulation Principles*, discusses the principles of modulation.

Module 13, *Introduction to Number Systems and Logic Circuits*, presents the fundamental concepts of number systems, Boolean algebra, and logic circuits, all of which pertain to digital computers.

Module 14, *Introduction to Microelectronics*, covers microelectronics technology and miniature and microminiature circuit repair.

Module 15, *Principles of Synchros, Servos, and Gyros*, provides the basic principles, operations, functions, and applications of synchro, servo, and gyro mechanisms.

Module 16, *Introduction to Test Equipment*, is an introduction to some of the more commonly used test equipments and their applications.

Module 17, *Radio-Frequency Communications Principles*, presents the fundamentals of a radio-frequency communications system.

Module 18, *Radar Principles*, covers the fundamentals of a radar system.

Module 19, *The Technician's Handbook*, is a handy reference of commonly used general information, such as electrical and electronic formulas, color coding, and naval supply system data.

Module 20, *Master Glossary*, is the glossary of terms for the series.

Module 21, *Test Methods and Practices*, describes basic test methods and practices.

Module 22, *Introduction to Digital Computers*, is an introduction to digital computers.

Module 23, *Magnetic Recording*, is an introduction to the use and maintenance of magnetic recorders and the concepts of recording on magnetic tape and disks.

Module 24, *Introduction to Fiber Optics*, is an introduction to fiber optics.

Embedded questions are inserted throughout each module, except for modules 19 and 20, which are reference books. If you have any difficulty in answering any of the questions, restudy the applicable section.

Although an attempt has been made to use simple language, various technical words and phrases have necessarily been included. Specific terms are defined in Module 20, *Master Glossary*.

Considerable emphasis has been placed on illustrations to provide a maximum amount of information. In some instances, a knowledge of basic algebra may be required.

Assignments are provided for each module, with the exceptions of Module 19, *The Technician's Handbook*; and Module 20, *Master Glossary*. Course descriptions and ordering information are in NAVEDTRA 12061, *Catalog of Nonresident Training Courses*.

Throughout the text of this course and while using technical manuals associated with the equipment you will be working on, you will find the below notations at the end of some paragraphs. The notations are used to emphasize that safety hazards exist and care must be taken or observed.

WARNING

AN OPERATING PROCEDURE, PRACTICE, OR CONDITION, ETC., WHICH MAY RESULT IN INJURY OR DEATH IF NOT CAREFULLY OBSERVED OR FOLLOWED.

CAUTION

AN OPERATING PROCEDURE, PRACTICE, OR CONDITION, ETC., WHICH MAY RESULT IN DAMAGE TO EQUIPMENT IF NOT CAREFULLY OBSERVED OR FOLLOWED.

NOTE

An operating procedure, practice, or condition, etc., which is essential to emphasize.

INSTRUCTIONS FOR TAKING THE COURSE

ASSIGNMENTS

The text pages that you are to study are listed at the beginning of each assignment. Study these pages carefully before attempting to answer the questions. Pay close attention to tables and illustrations and read the learning objectives. The learning objectives state what you should be able to do after studying the material. Answering the questions correctly helps you accomplish the objectives.

SELECTING YOUR ANSWERS

Read each question carefully, then select the BEST answer. You may refer freely to the text. The answers must be the result of your own work and decisions. You are prohibited from referring to or copying the answers of others and from giving answers to anyone else taking the course.

SUBMITTING YOUR ASSIGNMENTS

To have your assignments graded, you must be enrolled in the course with the Nonresident Training Course Administration Branch at the Naval Education and Training Professional Development and Technology Center (NETPDTC). Following enrollment, there are two ways of having your assignments graded: (1) use the Internet to submit your assignments as you complete them, or (2) send all the assignments at one time by mail to NETPDTC.

Grading on the Internet: Advantages to Internet grading are:

- you may submit your answers as soon as you complete an assignment, and
- you get your results faster; usually by the next working day (approximately 24 hours).

In addition to receiving grade results for each assignment, you will receive course completion confirmation once you have completed all the

assignments. To submit your assignment answers via the Internet, go to:

<http://courses.cnet.navy.mil>

Grading by Mail: When you submit answer sheets by mail, send all of your assignments at one time. Do NOT submit individual answer sheets for grading. Mail all of your assignments in an envelope, which you either provide yourself or obtain from your nearest Educational Services Officer (ESO). Submit answer sheets to:

COMMANDING OFFICER
NETPDTC N331
6490 SAUFLEY FIELD ROAD
PENSACOLA FL 32559-5000

Answer Sheets: All courses include one “scannable” answer sheet for each assignment. These answer sheets are preprinted with your SSN, name, assignment number, and course number. Explanations for completing the answer sheets are on the answer sheet.

Do not use answer sheet reproductions: Use only the original answer sheets that we provide—reproductions will not work with our scanning equipment and cannot be processed.

Follow the instructions for marking your answers on the answer sheet. Be sure that blocks 1, 2, and 3 are filled in correctly. This information is necessary for your course to be properly processed and for you to receive credit for your work.

COMPLETION TIME

Courses must be completed within 12 months from the date of enrollment. This includes time required to resubmit failed assignments.

PASS/FAIL ASSIGNMENT PROCEDURES

If your overall course score is 3.2 or higher, you will pass the course and will not be required to resubmit assignments. Once your assignments have been graded you will receive course completion confirmation.

If you receive less than a 3.2 on any assignment and your overall course score is below 3.2, you will be given the opportunity to resubmit failed assignments. **You may resubmit failed assignments only once.** Internet students will receive notification when they have failed an assignment--they may then resubmit failed assignments on the web site. Internet students may view and print results for failed assignments from the web site. Students who submit by mail will receive a failing result letter and a new answer sheet for resubmission of each failed assignment.

COMPLETION CONFIRMATION

After successfully completing this course, you will receive a letter of completion.

ERRATA

Errata are used to correct minor errors or delete obsolete information in a course. Errata may also be used to provide instructions to the student. If a course has an errata, it will be included as the first page(s) after the front cover. Errata for all courses can be accessed and viewed/downloaded at:

<http://www.advancement.cnet.navy.mil>

STUDENT FEEDBACK QUESTIONS

We value your suggestions, questions, and criticisms on our courses. If you would like to communicate with us regarding this course, we encourage you, if possible, to use e-mail. If you write or fax, please use a copy of the Student Comment form that follows this page.

For subject matter questions:

E-mail: n315.products@cnet.navy.mil
Phone: Comm: (850) 452-1001, ext. 1728
DSN: 922-1001, ext. 1728
FAX: (850) 452-1370
(Do not fax answer sheets.)
Address: COMMANDING OFFICER
NETPDTC N315
6490 SAUFLEY FIELD ROAD
PENSACOLA FL 32509-5237

For enrollment, shipping, grading, or completion letter questions

E-mail: fleetservices@cnet.navy.mil
Phone: Toll Free: 877-264-8583
Comm: (850) 452-1511/1181/1859
DSN: 922-1511/1181/1859
FAX: (850) 452-1370
(Do not fax answer sheets.)
Address: COMMANDING OFFICER
NETPDTC N331
6490 SAUFLEY FIELD ROAD
PENSACOLA FL 32559-5000

NAVAL RESERVE RETIREMENT CREDIT

If you are a member of the Naval Reserve, you will receive retirement points if you are authorized to receive them under current directives governing retirement of Naval Reserve personnel. For Naval Reserve retirement, this course is evaluated at 6 points. (Refer to *Administrative Procedures for Naval Reservists on Inactive Duty*, BUPERSINST 1001.39, for more information about retirement points.)

Student Comments

Course Title: *NEETS Module 10*
Introduction to Wave Propagation, Transmission Lines, and Antennas

NAVEDTRA: 14182 **Date:** _____

We need some information about you:

Rate/Rank and Name: _____ SSN: _____ Command/Unit _____

Street Address: _____ City: _____ State/FPO: _____ Zip _____

Your comments, suggestions, etc.:

| |
|--|
| <p>Privacy Act Statement: Under authority of Title 5, USC 301, information regarding your military status is requested in processing your comments and in preparing a reply. This information will not be divulged without written authorization to anyone other than those within DOD for official use in determining performance.</p> |
|--|

NETPDTC 1550/41 (Rev 4-00)

CHAPTER 1

WAVE PROPAGATION

LEARNING OBJECTIVES

Learning objectives are stated at the beginning of each chapter. These learning objectives serve as a preview of the information you are expected to learn in the chapter. The comprehensive check questions are based on the objectives. By successfully completing the NRTC, you indicate that you have met the objectives and have learned the information. The learning objectives are listed below.

Upon completion of this chapter, you should be able to:

1. State what wave motion is, define the terms reflection, refraction, and diffraction, and describe the Doppler effect.
2. State what sound waves are and define a propagating medium.
3. List and define terms as applied to sound waves, such as cycle, frequency, wavelength, and velocity.
4. List the three requirements for sound.
5. Define pitch, intensity, loudness, and quality and their application to sound waves.
6. State the acoustical effects that echoes, reverberation, resonance, and noise have on sound waves.
7. Define light waves and list their characteristics.
8. List the various colors of light and define the terms reflection, refraction, diffusion, and absorption as applied to light waves.
9. State the difference between sound waves and light waves.
10. State the electromagnetic wave theory and list the components of the electromagnetic wave.

INTRODUCTION TO WAVE PROPAGATION

Of the many technical subjects that naval personnel are expected to know, probably the one least susceptible to change is the theory of wave propagation. The basic principles that enable waves to be propagated (transmitted) through space are the same today as they were 70 years ago. One would think, then, that a thorough understanding of these principles is a relatively simple task. For the electrical engineer or the individual with a natural curiosity for the unknown, it is indeed a simple task. Most technicians, however, tend to view wave propagation as something complex and confusing, and would just as soon see this chapter completely disappear from training manuals. This attitude undoubtedly stems from the fact that wave propagation is an invisible force that cannot be detected by the sense of sight or touch. Understanding wave propagation requires the use of the imagination to visualize the associated concepts and how they are used in practical application. This manual was developed to help you visualize

and understand those concepts. Through ample use of illustrations and a step-by-step transition from the simple to the complex, we will help you develop a better understanding of wave propagation. In this chapter, we will discuss propagation theory on an introductory level, without going into the technical details that concern the engineer. However, you must still use thought and imagination to understand the new ideas and concepts as they are presented.

To understand radio wave propagation, you must first learn what wave propagation is and some of the basic physics or properties that affect propagation. Many of these properties are common everyday occurrences, with which you are already familiar.

WHAT IS PROPAGATION?

Early man was quick to recognize the need to communicate beyond the range of the human voice. To satisfy this need, he developed alternate methods of communication, such as hand gestures, beating on a hollow log, and smoke signals. Although these methods were effective, they were still greatly limited in range. Eventually, the range limitations were overcome by the development of courier and postal systems; but there was then a problem of speed. For centuries the time required for the delivery of a message depended on the speed of a horse.

During the latter part of the 19th century, both distance and time limitations were largely overcome. The invention of the telegraph made possible instantaneous communication over long wires. Then a short time later, man discovered how to transmit messages in the form of RADIO WAVES.

As you will learn in this chapter, radio waves are propagated. PROPAGATION means "movement through a medium." This is most easily illustrated by light rays. When a light is turned on in a darkened room, light rays travel from the light bulb throughout the room. When a flashlight is turned on, light rays also radiate from its bulb, but are focused into a narrow beam. You can use these examples to picture how radio waves propagate. Like the light in the room, radio waves may spread out in all directions. They can also be focused (concentrated) like the flashlight, depending upon the need. Radio waves are a form of radiant energy, similar to light and heat. Although they can neither be seen nor felt, their presence can be detected through the use of sensitive measuring devices. The speed at which both forms of waves travel is the same; they both travel at the speed of light.

You may wonder why you can see light but not radio waves, which consist of the same form of energy as light. The reason is that you can only "see" what your eyes can detect. Your eyes can detect radiant energy only within a fixed range of frequencies. Since the frequencies of radio waves are below the frequencies your eyes can detect, you cannot see radio waves.

The theory of wave propagation that we discuss in this module applies to Navy electronic equipment, such as radar, navigation, detection, and communication equipment. We will not discuss these individual systems in this module, but we will explain them in future modules.

Q1. What is propagation?

PRINCIPLES OF WAVE MOTION

All things on the earth—on the land, or in the water—are showered continually with waves of energy. Some of these waves stimulate our senses and can be seen, felt, or heard. For instance, we can see light, hear sound, and feel heat. However, there are some waves that do not stimulate our senses. For

example, radio waves, such as those received by our portable radio or television sets, cannot be seen, heard, or felt. A device must be used to convert radio waves into light (TV pictures) and sound (audio) for us to sense them.

A WAVE can be defined as a DISTURBANCE (sound, light, radio waves) that moves through a MEDIUM (air, water, vacuum). To help you understand what is meant by "a disturbance which moves through a medium," picture the following illustration. You are standing in the middle of a wheat field. As the wind blows across the field toward you, you can see the wheat stalks bending and rising as the force of the wind moves into and across them. The wheat appears to be moving toward you, but it isn't. Instead, the stalks are actually moving back and forth. We can then say that the "medium" in this illustration is the wheat and the "disturbance" is the wind moving the stalks of wheat.

WAVE MOTION can be defined as a recurring disturbance advancing through space with or without the use of a physical medium. Wave motion, therefore, is a means of moving or transferring energy from one point to another point. For example, when sound waves strike a microphone, sound energy is converted into electrical energy. When light waves strike a phototransistor or radio waves strike an antenna, they are likewise converted into electrical energy. Therefore, sound, light, and radio waves are all forms of energy that are moved by wave motion. We will discuss sound waves, light waves, and radio waves later.

Q2. How is a wave defined as it applies to wave propagation?

Q3. What is wave motion?

Q4. What are some examples of wave motion?

WAVE MOTION IN WATER

A type of wave motion familiar to almost everyone is the movement of waves in water. We will explain these waves first to help you understand wave motion and the terms used to describe it.

Basic wave motion can be shown by dropping a stone into a pool of water (see figure 1-1). As the stone enters the water, a surface disturbance is created, resulting in an expanding series of circular waves. Figure 1-2 is a diagram of this action. View A shows the falling stone just an instant before it strikes the water. View B shows the action taking place at the instant the stone strikes the surface, pushing the water that is around it upward and outward. In view C, the stone has sunk deeper into the water, which has closed violently over it causing some spray, while the leading wave has moved outward. An instant later, the stone has sunk out of sight, leaving the water disturbed as shown in view D. Here the leading wave has continued to move outward and is followed by a series of waves gradually diminishing in amplitude. Meanwhile, the disturbance at the original point of contact has gradually subsided.

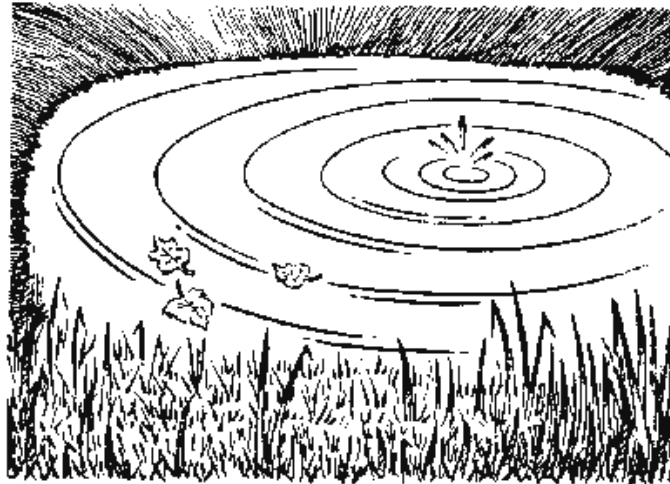

Figure 1-1.—Formation of waves in water.

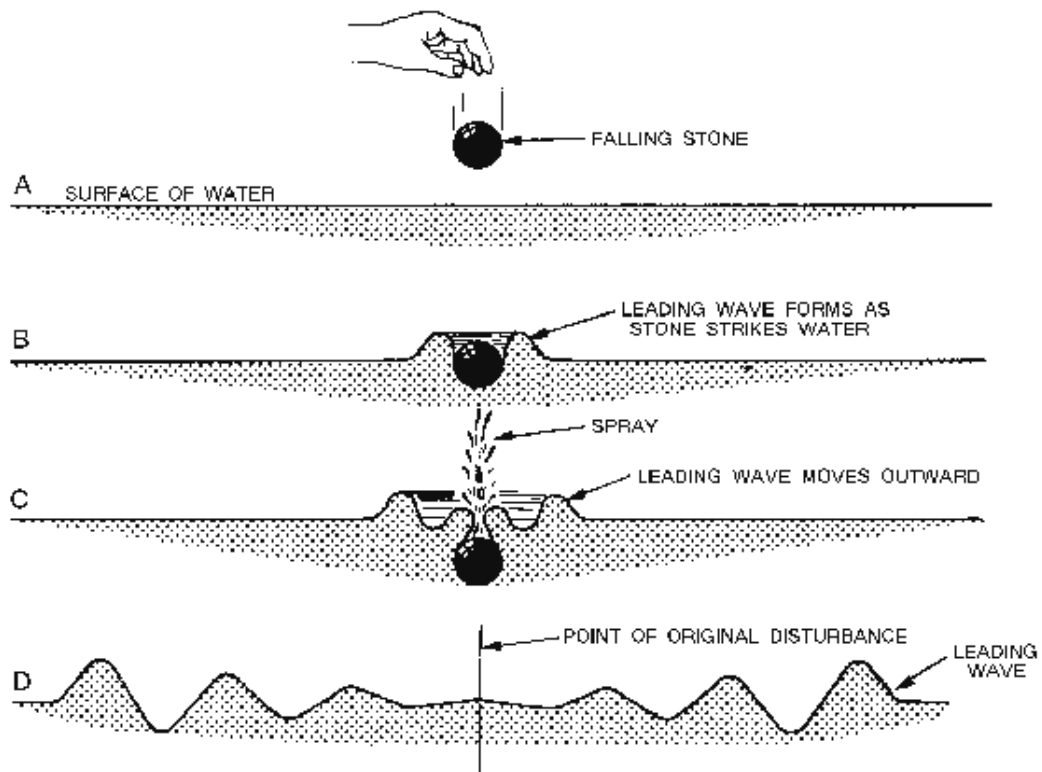

Figure 1-2.—How a falling stone creates wave motion to the surface of water.

In this example, the water is not actually being moved outward by the motion of the waves, but up and down as the waves move outward. The up and down motion is transverse, or at right angles, to the outward motion of the waves. This type of wave motion is called **TRANSVERSE WAVE MOTION**.

Q5. What type of wave motion is represented by the motion of water?

TRANSVERSE WAVES

To explain transverse waves, we will again use our example of water waves. Figure 1-3 is a cross section diagram of waves viewed from the side. Notice that the waves are a succession of crests and troughs. The wavelength (one 360 degree cycle) is the distance from the crest of one wave to the crest of the next, or between any two similar points on adjacent waves. The amplitude of a transverse wave is half the distance measured vertically from the crest to the trough. Water waves are known as transverse waves because the motion of the water is up and down, or at right angles to the direction in which the waves are traveling. You can see this by observing a cork bobbing up and down on water as the waves pass by; the cork moves very little in a sideways direction. In figure 1-4, the small arrows show the up-and-down direction the cork moves as the transverse wave is set in motion. The direction the wave travels is shown by the large arrow. Radio waves, light waves, and heat waves are examples of transverse waves.

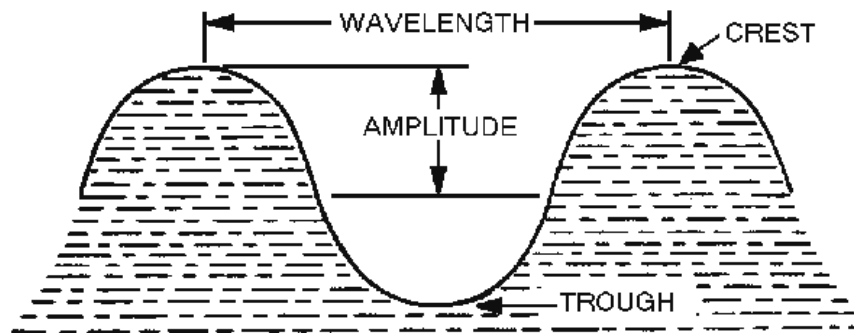

Figure 1-3.—Elements of a wave.

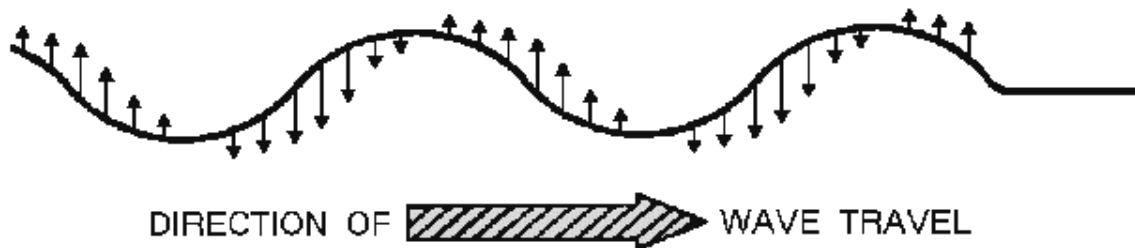

Figure 1-4.—Transverse wave.

LONGITUDINAL WAVES

In the previous discussion, we listed radio waves, light waves, and heat waves as examples of transverse waves, but we did not mention sound waves. Why? Simply because sound waves are **LONGITUDINAL WAVES**. Unlike transverse waves, which travel at right angles to the direction of propagation, sound waves travel back and forth in the same direction as the wave motion. Therefore, longitudinal waves are waves in which the disturbance takes place in the direction of propagation. Longitudinal waves are sometimes called **COMPRESSION WAVES**.

Waves that make up sound, such as those set up in the air by a vibrating tuning fork, are longitudinal waves. In figure 1-5, the tuning fork, when struck, sets up vibrations. As the tine moves in an outward direction, the air immediately in front of it is compressed (made more dense) so that its momentary

pressure is raised above that at other points in the surrounding medium (air). Because air is elastic, the disturbance is transmitted in an outward direction as a **COMPRESSION WAVE**. When the tine returns and moves in the inward direction, the air in front of the tine is rarefied (made less dense or expanded) so that its pressure is lowered below that of the other points in the surrounding air. The rarefied wave is propagated from the tuning fork and follows the compressed wave through the medium (air).

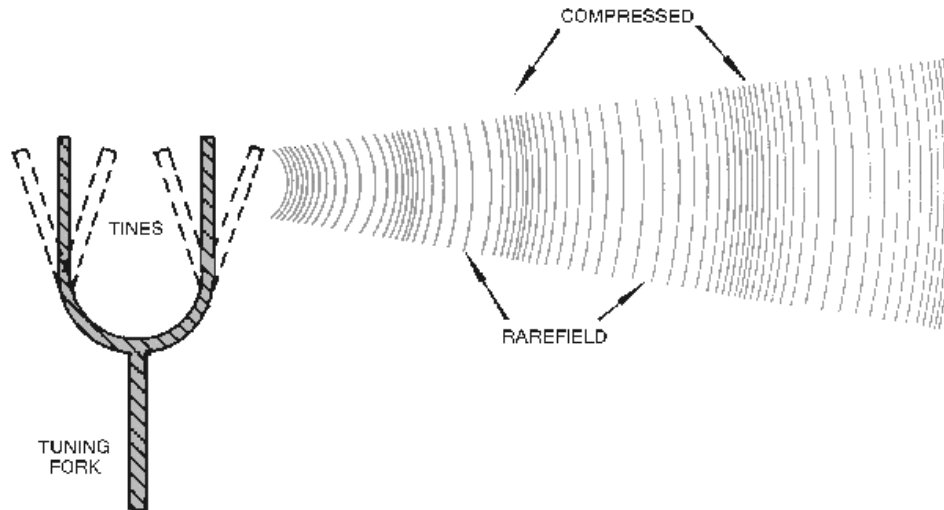

Figure 1-5.—Sound propagation by a tuning fork.

Q6. What are some examples of transverse waves?

Q7. What example of a longitudinal wave was given in the text?

MEDIUM

We have used the term *medium* in describing the motion of waves. Since *medium* is a term that is used frequently in discussing propagation, it needs to be defined so you will understand what a medium is and its application to propagation.

A **MEDIUM** is the vehicle through which the wave travels from one point to the next. The vehicle that carries a wave can be just about anything. An example of a medium, already mentioned, is air. Air, as defined by the dictionary, is the mixture of invisible, odorless, tasteless gases that surrounds the earth (the atmosphere). Air is made up of molecules of various gases (and impurities). We will call these molecules of air *particles of air* or simply *particles*.

Figure 1-6 will help you to understand how waves travel through air. The object producing the waves is called the **SOURCE**—a bell in this illustration. The object responding to the waves is called a **DETECTOR** or **RECEIVER**—in this case, the human ear. The medium is air, which is the means of conveying the waves from the source to the detector. The source, detector, and medium are all necessary for wave motion and wave propagation (except for electromagnetic waves which require no medium). The waves shown in figure 1-6 are sound waves. As the bell is rung, the particles of air around the bell are compressed and then expanded. This compression and expansion of particles of air set up a wave motion in the air. As the waves are produced, they carry energy from particle to particle through the medium (air) to the detector (ear).

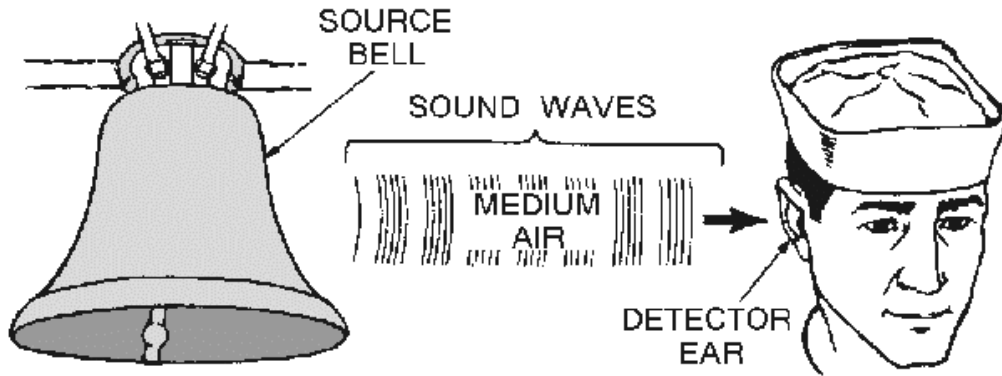

Figure 1-6.—The three elements of sound.

Q8. *What are the three requirements for a wave to be propagated?*

TERMS USED IN WAVE MOTION

There are a number of special terms concerning waves that you should know. Many of the terms, such as CYCLE, WAVELENGTH, AMPLITUDE, and FREQUENCY were introduced in previous *NEETS* modules. We will now discuss these terms in detail as they pertain to wave propagation. Before we begin our discussion, however, note that in the figure, wave 1 and wave 2 have equal frequency and wavelength but different amplitudes. The REFERENCE LINE (also known as REST POSITION or POINT OF ZERO DISPLACEMENT) is the position that a particle of matter would have if it were not disturbed by wave motion. For example, in the case of the water wave, the reference line is the level of the water when no wave motion is present. With this in mind, let's go on to our discussion of the four terms, as shown in figure 1-7.

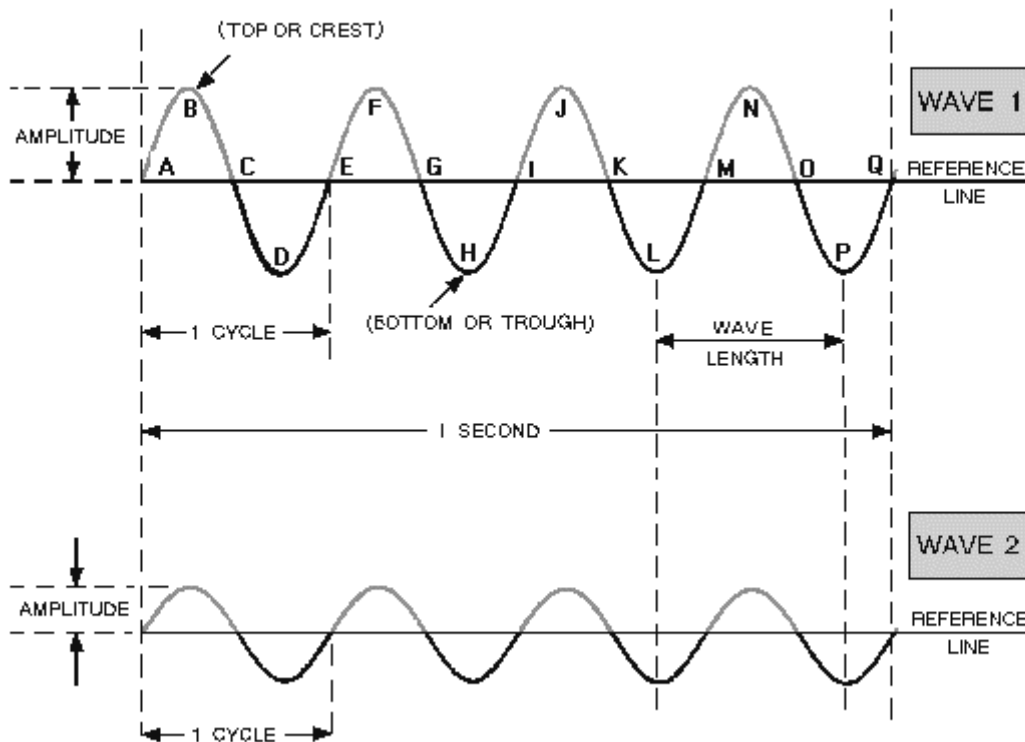

Figure 1-7.—Comparison of waves with different amplitudes.

Cycle

Refer to wave 1 in figure 1-7. Notice how similar it is to the sine wave you have already studied. All transverse waves appear as sine waves when viewed from the side. In figure 1-7, wave 1 has four complete cycles. Points ABCDE comprise one complete cycle having a maximum value above and a maximum value below the reference line. The portion above the reference line (between points A and C) is called a **POSITIVE ALTERNATION** and the portion below the reference line (between points C and E) is known as a **NEGATIVE ALTERNATION**. The combination of one complete positive and one complete negative alternation represents one cycle of the wave. At point E, the wave begins to repeat itself with a second cycle completed at point I, a third at point M, etc. The peak of the positive alternation (maximum value above the line) is sometimes referred to as the **TOP** or **CREST**, and the peak of the negative alternation (maximum value below the line) is sometimes called the **BOTTOM** or **TROUGH**, as depicted in the figure. Therefore, one cycle has one crest and one trough.

Wavelength

A **WAVELENGTH** is the distance in space occupied by one cycle of a radio wave at any given instant. If the wave could be frozen in place and measured, the wavelength would be the distance from the leading edge of one cycle to the corresponding point on the next cycle. Wavelengths vary from a few hundredths of an inch at extremely high frequencies to many miles at extremely low frequencies; however, common practice is to express wavelengths in meters. Therefore, in figure 1-7 (wave 1), the distance between A and E, or B and F, etc., is one wavelength. The Greek letter lambda (λ) is used to signify wavelength. Why lambda and not "I" or "L"? This is because "L" is used conventionally as the

symbol for inductance, and "l" is used for dimensional length; therefore, λ ; is used to indicate the length of waves.

Amplitude

Two waves may have the same wavelength, but the crest of one may rise higher above the reference line than the crest of the other. Compare wave 1 and wave 2 of figure 1-7 again. The height of a wave crest above the reference line is called the **AMPLITUDE** of the wave. The amplitude of a wave gives a relative indication of the amount of energy the wave transmits. A continuous series of waves, such as A through Q, having the same amplitude and wavelength, is called a train of waves or **WAVE TRAIN**.

Frequency and Time

Time is an important factor in wave studies. When a wave train passes through a medium, a certain number of individual waves pass a given point in a specific unit of time. For example, if a cork on a water wave rises and falls once every second, the wave makes one complete up-and-down vibration every second. The number of vibrations, or cycles, of a wave train in a unit of time is called the **FREQUENCY** of the wave train and is measured in **HERTZ**. If 5 waves pass a point in one second, the frequency of the wave train is 5 cycles per second. In figure 1-7, the frequency of both wave 1 and wave 2 is four cycles per second (cycles per second is abbreviated as cps).

In 1967, in honor of the German physicist Heinrich Hertz, the term **HERTZ** was designated for use in lieu of the term "cycle per second" when referring to the frequency of radio waves. It may seem confusing that in one place the term "cycle" is used to designate the positive and negative alternations of a wave, but in another instance the term "hertz" is used to designate what appears to be the same thing. The key is the time factor. The term cycle refers to any sequence of events, such as the positive and negative alternations, comprising one cycle of electrical current. The term hertz refers to the number of occurrences that take place in one second.

Q9. What is a cycle?

Q10. What is wavelength (λ)?

CHARACTERISTICS OF WAVE MOTION

The two types of wave motion, transverse and longitudinal, have many of the same characteristics, such as frequency, amplitude, and wavelength. Another important characteristic that these two types of wave motion share is **VELOCITY**. Velocity of propagation is the rate at which the disturbance travels through the medium, or the velocity with which the crest of the wave moves along. The velocity of the wave depends both on the type of wave (light, sound, or radio) and type of medium (air, water, or metal). If longitudinal waves are plotted as a graph, they appear as transverse waves. This fact is illustrated in figure 1-8.

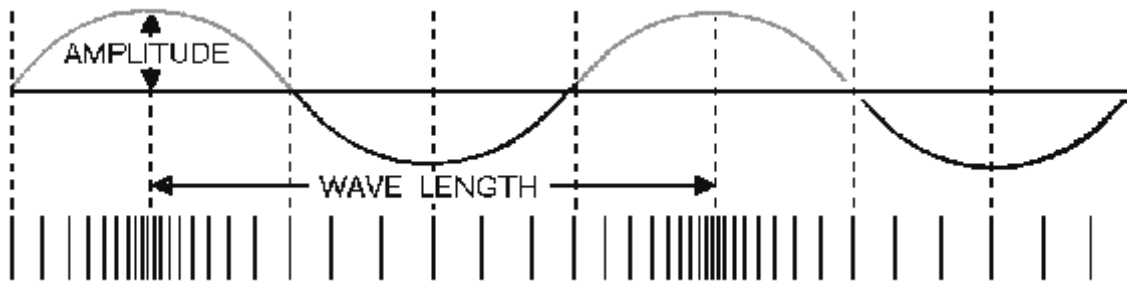

Figure 1-8.—Longitudinal wave represented graphically by a transverse wave.

The frequency of a longitudinal wave, like that of a transverse wave, is the number of complete cycles the wave makes during a specific unit of time. The higher the frequency, the greater is the number of compressions and expansions per unit of time.

In the two types of wave motion described in the preceding discussion, the following quantities are of interest:

- a. The PERIOD, which is the time (T) in which one complete vibratory cycle of events occurs,
- b. The FREQUENCY OF VIBRATION (f), which is the number of cycles taking place in one second, and
- c. The WAVELENGTH, which is the distance the disturbance travels during one period of vibration.

Now, consider the following concept. If a vibrating object makes a certain number of vibrations per second, then 1 second divided by the number of vibrations is equal to the period of time of 1 vibration. In other words, the period, or time, of 1 vibration is the reciprocal of the frequency; thus,

time (T) of one vibration =

$$\frac{1}{\text{frequency (f)}}$$

or

$$T = \frac{1}{f}$$

If you know the velocity of a wave, you can determine the wavelength by dividing the velocity by the frequency. As an equation:

Where:

$$\lambda = \frac{v}{f}$$

λ = wavelength

v = velocity of propagation

f = frequency of vibration

When you use the above equation, be careful to express velocity and wavelength in the proper units of length. For example, in the English system, if the velocity (expressed in feet per second) is divided by the frequency (expressed in cycles per second, or Hz), the wavelength is given in feet per cycle. If the metric system is used and the velocity (expressed in meters per second) is divided by the frequency (expressed in cycles per second), the wavelength is given in meters per cycle. Be sure to express both the wavelength and the frequency in the same units. (Feet per cycle and meters per cycle are normally abbreviated as feet or meters because one wavelength indicates one cycle.) Because this equation holds true for both transverse and longitudinal waves, it is used in the study of both electromagnetic waves and sound waves.

Consider the following example. Two cycles of a wave pass a fixed point every second, and the velocity of the wave train is 4 feet per second. What is the wavelength? The formula for determining wavelength is as follows:

$$\lambda = \frac{v}{f}$$

Where:

λ = wavelength in feet

v = velocity in feet per second

f = frequency in Hz

Given:

v = 4 feet per second

f = 2 Hz

Solution:

$$\lambda = \frac{v}{f}$$

$$\lambda = \frac{4 \text{ feet per second}}{2 \text{ Hz}}$$

$$\lambda = 2 \text{ feet}$$

NOTE: In problems of this kind, be sure NOT to confuse wave velocity with frequency. **FREQUENCY** is the number of cycles per unit of time (Hz). **WAVE VELOCITY** is the speed with which a wave train passes a fixed point.

Here is another problem. If a wave has a velocity of 1,100 feet per second and a wavelength of 30 feet, what is the frequency of the wave?

By transposing the general equation:

By transposing the general equation:

$$f = \frac{v}{\lambda}$$

We have the equation:

$$\lambda = \frac{v}{f}$$

Given:

$$v = 1,100 \text{ feet per second}$$

$$\lambda = 30 \text{ feet}$$

Solution:

$$f = \frac{1,100 \text{ feet per second}}{30 \text{ feet}}$$

$$f = 36.67\text{Hz}$$

To find the velocity, rewrite the equation as:

$$v = \lambda f$$

Let's work one more problem, this time using the metric system.

Suppose the wavelength is 0.4 meters and the frequency is 12 kHz. What is the velocity?

Use the formula:

$$\text{velocity} = \text{wavelength} \times \text{frequency} (v = \lambda f)$$

Given:

$$\text{wavelength } (\lambda) = 0.4 \text{ meters}$$

$$\text{frequency } (f) = 12\text{kHz}$$

Solution:

$$v = \lambda \times f$$

$$v = 0.4 \text{ meters} \times 12,000\text{Hz}$$

$$v = 4,800 \text{ meters per second}$$

Other important characteristics of wave motion are reflection, refraction, diffraction, and the Doppler effect. Big words, but the concept of each is easy to see. For ease of understanding, we will explain the first two characteristics using light waves, and the last two characteristics using sound waves. You should keep in mind that all waves react in a similar manner.

Within mediums, such as air, solids, or gases, a wave travels in a straight line. When the wave leaves the boundary of one medium and enters the boundary of a different medium, the wave changes direction. For our purposes in this module, a boundary is an imaginary line that separates one medium from another.

When a wave passes through one medium and encounters a medium having different characteristics, three things can occur to the wave: (1) Some of the energy can be reflected back into the initial medium; (2) some of the energy can be transmitted into the second medium where it may continue at a different velocity; or (3) some of the energy can be absorbed by the medium. In some cases, all three processes (reflection, transmission, and absorption) may occur to some degree.

Reflection

REFLECTION WAVES are simply waves that are neither transmitted nor absorbed, but are reflected from the surface of the medium they encounter. If a wave is directed against a reflecting surface, such as a mirror, it will reflect or "bounce" from the mirror. Refer to figure 1-9. A wave directed *toward* the surface of the mirror is called the INCIDENT wave. When the wave bounces off of the mirror, it becomes known as the REFLECTED wave. An imaginary line perpendicular to the mirror at the point at which the incident wave strikes the mirror's surface is called the NORMAL, or perpendicular. The angle between the incident wave and the normal is called the ANGLE OF INCIDENCE. The angle between the reflected wave and the normal is called the ANGLE OF REFLECTION.

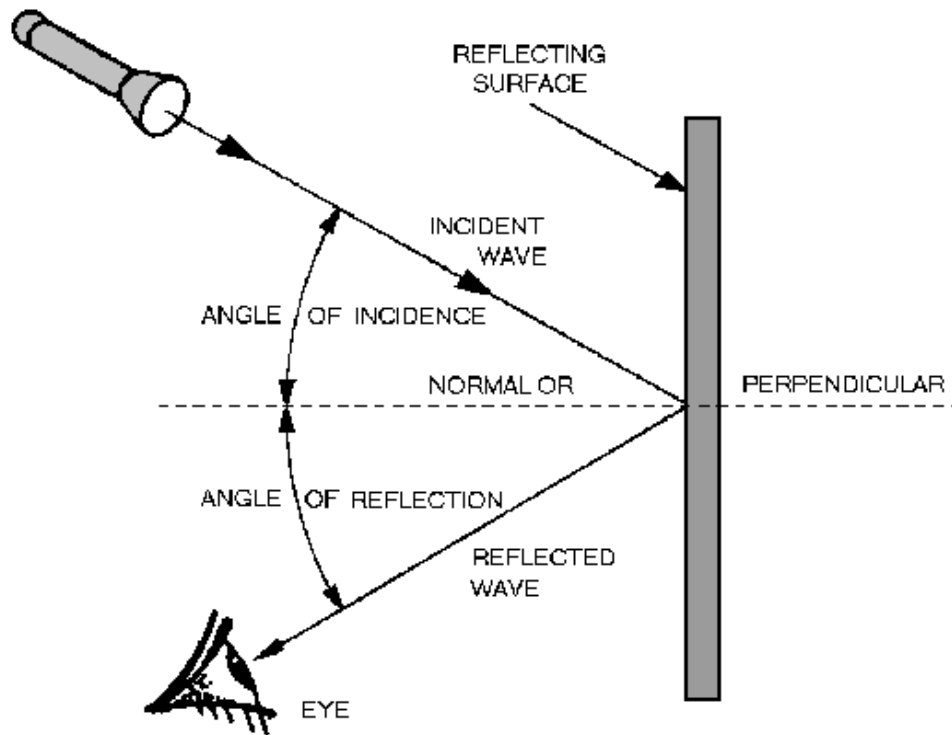

Figure 1-9.—Reflection of a wave.

If the reflecting surface is smooth and polished, the angle between the incident ray and the normal will be the same as the angle between the reflected ray and the normal. This conforms to the law of reflection which states: The angle of incidence is equal to the angle of reflection.

The amount of incident wave energy reflected from a given surface depends on the nature of the surface and the angle at which the wave strikes the surface. As the angle of incidence increases, the amount of wave energy reflected increases. The reflected energy is the greatest when the wave is nearly parallel to the reflecting surface. When the incident wave is perpendicular to the surface, more of the energy is transmitted into the substance and less is reflected. At any incident angle, a mirror reflects almost all of the wave energy, while a dull, black surface reflects very little.

Q11. What is the law of reflection?

Q12. When a wave is reflected from a surface, energy is transferred. When is the transfer of energy greatest?

Q13. When is the transfer of energy minimum?

Refraction

When a wave passes from one medium into another medium that has a different velocity of propagation, a change in the direction of the wave will occur. This changing of direction as the wave enters the second medium is called REFRACTION. As in the discussion of reflection, the wave striking the boundary (surface) is called the INCIDENT WAVE, and the imaginary line perpendicular to the boundary is called the NORMAL. The angle between the incident wave and the normal is called the ANGLE OF INCIDENCE. As the wave passes through the boundary, it is bent either toward or away from the normal. The angle between the normal and the path of the wave through the second medium is the ANGLE OF REFRACTION.

A light wave passing through a block of glass is shown in figure 1-10. The wave moves from point A to B at a constant speed. This is the incident wave. As the wave penetrates the glass boundary at point B, the velocity of the wave is slowed down. This causes the wave to bend toward the normal. The wave then takes the path from point B to C through the glass and becomes BOTH the refracted wave from the top surface and the incident wave to the lower surface. As the wave passes from the glass to the air (the second boundary), it is again refracted, this time away from the normal and takes the path from point C to D. As the wave passes through the last boundary, its velocity increases to the original velocity. As figure 1-10 shows, refracted waves can bend toward or away from the normal. This bending depends on the velocity of the wave through each medium. The broken line between points B and E is the path that the wave would travel if the two mediums (air and glass) had the same density.

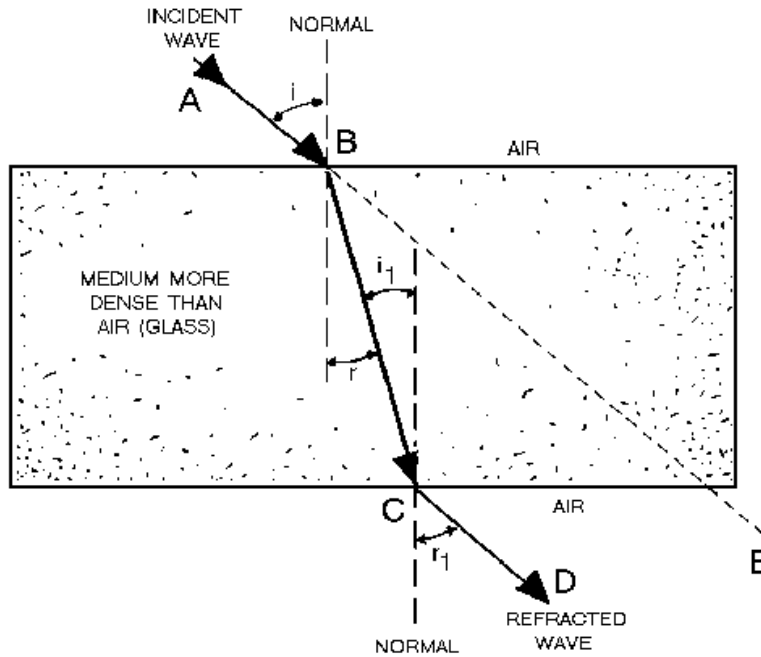

Figure 1-10.—Refraction of a wave.

To summarize what figure 1-10 shows:

1. If the wave passes from a less dense medium to a more dense medium, it is bent toward the normal, and the angle of refraction (r) is less than the angle of incidence (i).
2. If the wave passes from a more dense to a less dense medium, it is bent away from the normal, and the angle of refraction (r_1) is greater than the angle of incidence (i_1).

You can more easily understand refraction by looking at figure 1-11. There is a plowed field in the middle of a parade ground. Think of the incident wave as a company of recruits marching four abreast at an angle across the parade ground to the plowed field, then crossing the plowed field and coming out on the other side onto the parade ground again. As the recruits march diagonally across the parade ground and begin to cross the boundary onto the plowed field, the front line is slowed down. Because the recruits arrive at the boundary at different times, they will begin to slow down at different times (number 1 slows down first and number 4 slows down last in each line). The net effect is a bending action. When the recruits leave the plowed field and reenter the parade ground, the reverse action takes place.

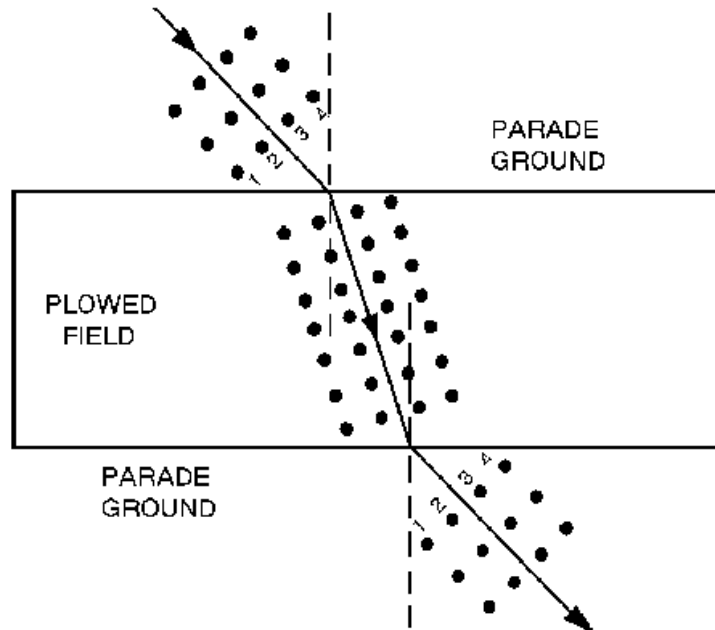

Figure 1-11.—Analogy of refraction.

Q14. A refracted wave occurs when a wave passes from one medium into another medium. What determines the angle of refraction?

Diffraction

DIFFRACTION is the bending of the wave path when the waves meet an obstruction. The amount of diffraction depends on the wavelength of the wave. Higher frequency waves are rarely diffracted in the normal world that surrounds us. Since light waves are high frequency waves, you will rarely see light diffracted. You can, however, observe diffraction in sound waves by listening to music. Suppose you are outdoors listening to a band. If you step behind a solid obstruction, such as a brick wall, you will hear mostly low notes. This is because the higher notes, having short wave lengths, undergo little or no diffraction and pass by or over the wall without wrapping around the wall and reaching your ears. The low notes, having longer wavelengths, wrap around the wall and reach your ears. This leads to the general statement that lower frequency waves tend to diffract more than higher frequency waves. Broadcast band (AM band) radio waves (lower frequency waves) often travel over a mountain to the opposite side from their source because of diffraction, while higher frequency TV and FM signals from the same source tend to be stopped by the mountain.

Doppler Effect

The last, but equally important, characteristic of a wave that we will discuss is the Doppler effect. The DOPPLER EFFECT is the apparent change in frequency or pitch when a sound source moves either toward or away from the listener, or when the listener moves either toward or away from the sound source. This principle, discovered by the Austrian physicist Christian Doppler, applies to all wave motion.

The apparent change in frequency between the source of a wave and the receiver of the wave is because of relative motion between the source and the receiver. To understand the Doppler effect, first assume that the frequency of a sound from a source is held constant. The wavelength of the sound will also remain constant. If both the source and the receiver of the sound remain stationary, the receiver will

hear the same frequency sound produced by the source. This is because the receiver is receiving the same number of waves per second that the source is producing. Now, if either the source or the receiver or both move toward the other, the receiver will perceive a higher frequency sound. This is because the receiver will receive a greater number of sound waves per second and interpret the greater number of waves as a higher frequency sound. Conversely, if the source and the receiver are moving apart, the receiver will receive a smaller number of sound waves per second and will perceive a lower frequency sound. In both cases, the frequency of the sound produced by the source will have remained constant.

For example, the frequency of the whistle on a fast-moving train sounds increasingly higher in pitch as the train is approaching than when the train is departing. Although the whistle is generating sound waves of a constant frequency, and though they travel through the air at the same velocity in all directions, the distance between the approaching train and the listener is decreasing. As a result, each wave has less distance to travel to reach the observer than the wave preceding it. Thus, the waves arrive with decreasing intervals of time between them.

These apparent changes in frequency, called the Doppler effect, affect the operation of equipment used to detect and measure wave energy. In dealing with electromagnetic wave propagation, the Doppler principle is used in equipment such as radar, target detection, weapons control, navigation, and sonar.

Q15. The apparent change in frequency or pitch because of motion is explained by what effect?

SOUND WAVES

The study of sound is important because of the role sound plays in the depth finding equipment (fathometer) and underwater detection equipment (sonar) used by the Navy.

As you know, sound travels through a medium by wave motion. Although sound waves and the electromagnetic waves used in the propagation of radio and radar differ, both types of waves have many of the same characteristics. Studying the principles of sound-wave motion will help you understand the actions of both sound waves and the more complex radio and radar electromagnetic waves. The major differences among sound waves, heat waves, and light waves are (1) their frequencies; (2) their types; the mediums through which they travel; and the velocities at which they travel.

SOUND—WHAT IS IT?

The word SOUND is used in everyday speech to signify a variety of things. One definition of sound is the sensation of hearing. Another definition refers to a stimulus that is capable of producing the sensation of hearing. A third definition limits sound to what is actually heard by the human ear.

In the study of physics, sound is defined as *a range of compression-wave frequencies to which the human ear is sensitive*. For the purpose of this chapter, however, we need to broaden the definition of sound to include compression waves that are not always audible to the human ear. To distinguish frequencies in the audible range from those outside that range, the words SONIC, ULTRASONIC, and INFRASONIC are used. Sounds capable of being heard by the human ear are called SONICS. The normal hearing range extends from about 20 to 20,000 hertz. However, to establish a standard sonic range, the Navy has set an arbitrary upper limit for sonics at 10,000 hertz and a lower limit at 15 hertz. Even though the average person can hear sounds above 10,000 hertz, it is standard practice to refer to sounds above that frequency as *ultrasonic*. Sounds between 15 hertz and 10,000 hertz are called *sonic*, while sounds below 15 hertz are known as *infrasonic* (formerly referred to as subsonic) sounds.

Q16. What term describes sounds capable of being heard by the human ear?

Q17. Are all sounds audible to the human ear? Why?

REQUIREMENTS FOR SOUND

Recall that sound waves are compression waves. The existence of compression waves depends on the transfer of energy. To produce vibrations that become sounds, a mechanical device (the source) must first receive an input of energy. Next, the device must be in contact with a medium that will receive the sound energy and carry it to a receiver. If the device is not in contact with a medium, the energy will not be transferred to a receiver, and there will be no sound.

Thus, three basic elements for transmission and reception of sound must be present before a sound can be produced. They are (1) the source (or transmitter), (2) a medium for carrying the sound (air, water, metal, etc.), and (3) the detector (or receiver).

A simple experiment provides convincing evidence that a medium must be present if sound is to be transferred. In figure 1-12, an electric bell is suspended by rubber bands in a bell jar from which the air can be removed. An external switch is connected from a battery to the bell so the bell may be rung intermittently. As the air is pumped out, the sound from the bell becomes weaker and weaker. If a perfect vacuum could be obtained, and if no sound were conducted out of the jar by the rubber bands, the sound from the bell would be completely inaudible. In other words, sound cannot be transmitted through a vacuum. When the air is admitted again, the sound is as loud as it was at the beginning. This experiment shows that when air is in contact with the vibrating bell, it carries energy to the walls of the jar, which in turn are set in vibration. Thus, the energy passes into the air outside of the jar and then on to the ear of the observer. This experiment illustrates that sound cannot exist in empty space (or a vacuum).

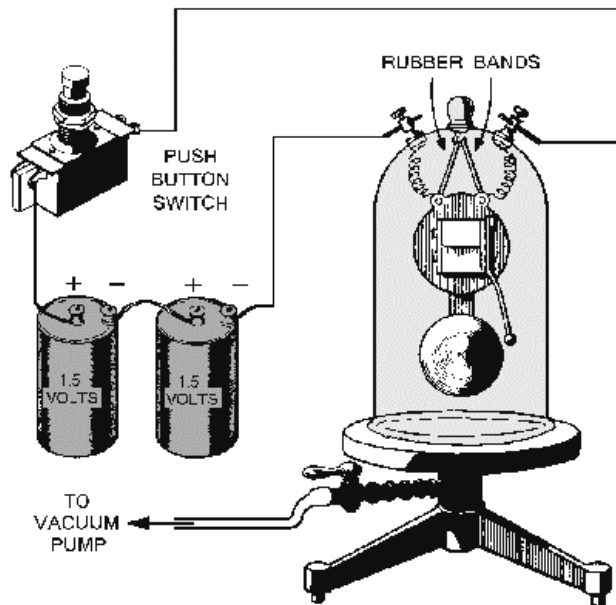

Figure 1-12.—No air, no sound.

Any object that moves rapidly back and forth, or vibrates, and thus disturbs the medium around it may be considered a source for sound. Bells, speakers, and stringed instruments are familiar sound sources.

The material through which sound waves travel is called the *medium*. The density of the medium determines the ease, distance, and speed of sound transmission. The higher the density of the medium, the slower sound travels through it.

The detector acts as the receiver of the sound wave. Because it does not surround the source of the sound wave, the detector absorbs only part of the energy from the wave and sometimes requires an amplifier to boost the weak signal.

As an illustration of what happens if one of these three elements is not present, let's refer to our experiment in which a bell was placed in a jar containing a vacuum. You could see the bell being struck, but you could hear no sound because there was no medium to transmit sound from the bell to you. Now let's look at another example in which the third element, the detector, is missing. You see a source (such as an explosion) apparently producing a sound, and you know the medium (air) is present, but you are too far away to hear the noise. Thus, as far as you are concerned, there is no detector and, therefore, no sound. We must assume, then, that sound can exist only when a source transmits sound through a medium, which passes it to a detector. Therefore, in the absence of any one of the basic elements (source, medium, detector) there can be NO sound.

Q18. Sound waves transmitted from a source are sometimes weak when they reach the detector. What instrument is needed to boost the weak signal?

TERMS USED IN SOUND WAVES

Sound waves vary in length according to their frequency. A sound having a long wavelength is heard at a low pitch (low frequency); one with a short wavelength is heard at a high pitch (high frequency). A complete wavelength is called a cycle. The distance from one point on a wave to the corresponding point on the next wave is a wavelength. The number of cycles per second (hertz) is the frequency of the sound. The frequency of a sound wave is also the number of vibrations per second produced by the sound source.

Q19. What are the three basic requirements for sound?

CHARACTERISTICS OF SOUND

Sound waves travel at great distances in a very short time, but as the distance increases the waves tend to spread out. As the sound waves spread out, their energy simultaneously spreads through an increasingly larger area. Thus, the wave energy becomes weaker as the distance from the source is increased.

Sounds may be broadly classified into two general groups. One group is NOISE, which includes sounds such as the pounding of a hammer or the slamming of a door. The other group is musical sounds, or TONES. The distinction between noise and tone is based on the regularity of the vibrations, the degree of damping, and the ability of the ear to recognize components having a musical sequence. You can best understand the physical difference between these kinds of sound by comparing the waveshape of a musical note, depicted in view A of figure 1-13, with the waveshape of noise, shown in view B. You can see by the comparison of the two waveshapes, that noise makes a very irregular and haphazard curve and a musical note makes a uniform and regular curve.

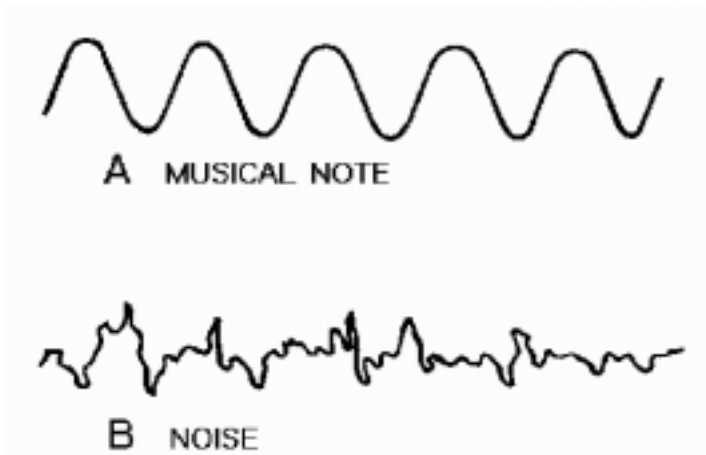

Figure 1-13.—Musical sound versus noise.

Sound has three basic characteristics: pitch, intensity, and quality. Each of these three characteristics is associated with one of the properties of the source or the type of waves which it produces. The pitch depends upon the frequency of the waves; the intensity depends upon the amplitude of the waves; and the quality depends upon the form of the waves. With the proper combination of these characteristics, the tone is pleasant to the ear. With the wrong combination, the sound quality turns into noise.

The Pitch of Sound

The term PITCH is used to describe the frequency of a sound. An object that vibrates many times per second produces a sound with a high pitch, as with a police whistle. The slow vibrations of the heavier strings of a violin cause a low-pitched sound. Thus, the frequency of the wave determines pitch. When the frequency is low, sound waves are long; when it is high, the waves are short. A sound can be so high in frequency that the waves reaching the ear cannot be heard. Likewise, some frequencies are so low that the eardrums do not convert them into sound. The range of sound that the human ear can detect varies with each individual.

The Intensity of Sound

The intensity of sound, at a given distance, depends upon the amplitude of the waves. Thus, a tuning fork gives out more energy in the form of sound when struck hard than when struck gently. You should remember that when a tuning fork is struck, the sound is omnidirectional (heard in all directions), because the sound waves spread out in all directions, as shown in figure 1-14. You can see from the figure that as the distance between the waves and the sound source increases, the energy in each wave spreads over a greater area; hence, the intensity of the sound decreases. The speaking tubes sometimes used aboard a ship prevent the sound waves from spreading in all directions by concentrating them in one desired direction (unidirectional), producing greater intensity. Therefore, the sound is heard almost at its original intensity at the opposite end of the speaking tube. The unidirectional megaphone and the directional loudspeaker also prevent sound waves from spreading in all directions.

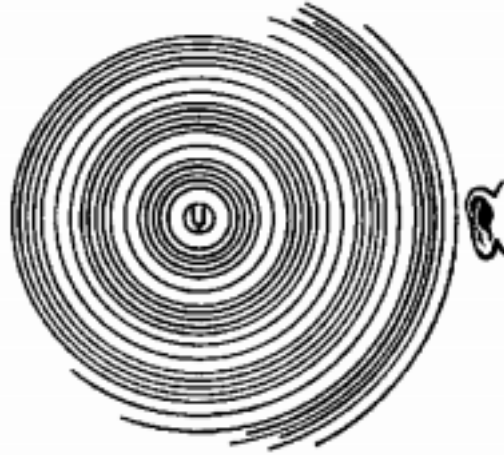

Figure 1-14.—Sound waves spread in all directions.

Sound intensity and loudness are often mistakenly interpreted as having the same meaning. Although they are related, they are not the same. Sound **INTENSITY** is a measure of the sound energy of a wave. **LOUDNESS**, on the other hand, is the sensation the intensity (and sometimes frequency) the sound wave produces on the ear. Increasing the intensity causes an increase in loudness but not in a direct proportion. For instance, doubling the loudness of a sound requires about a tenfold increase in the intensity of the sound.

Sound Quality

Most sounds, including musical notes, are not pure tones. They are a mixture of different frequencies (tones). A tuning fork, when struck, produces a pure tone of a specific frequency. This pure tone is produced by regular vibrations of the source (tines of the tuning fork). On the other hand, scraping your fingernails across a blackboard only creates noise, because the vibrations are irregular. Each individual pipe of a pipe organ is similar to a tuning fork, and each pipe produces a tone of a specific frequency. But sounding two or more pipes at the same time produces a complex waveform. A tone that closely imitates any of the vowel sounds can be produced by selecting the proper pipes and sounding them at the same time. Figure 1-15 illustrates the combining of two pure tones to make a **COMPLEX WAVE**.

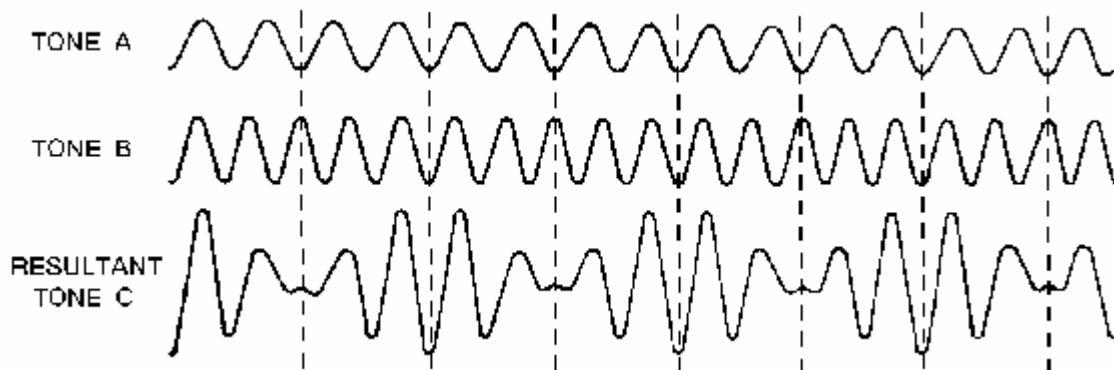

Figure 1-15.—Combination of tones.

The **QUALITY** of a sound depends on the complexity of its sound waves, such as the waves shown in tone C of figure 1-15. Almost all sounds (musical and vocal included) have complicated (complex)

waveforms. Tone A is a simple wave of a specific frequency that can be produced by a tuning fork, piano, organ, or other musical instrument. Tone B is also a simple wave but at a different frequency. When the two tones are sounded together, the complex waveform in tone C is produced. Note that tone C has the same frequency as tone A with an increase in amplitude. The human ear could easily distinguish between tone A and tone C because of the quality. Therefore, we can say that quality distinguishes tones of like pitch and loudness when sounded on different types of musical instruments. It also distinguishes the voices of different persons.

Q20. What are the two general groups of sound?

Q21. What are the three basic characteristics of sound?

Q22. What is the normal audible range of the human ear?

Q23. What is intensity as it pertains to sound?

Q24. What characteristic of sound enables a person to distinguish one musical instrument from another, if they are all playing the same note?

ELASTICITY AND DENSITY AND VELOCITY OF TRANSMISSION

Sound waves travel through any medium to a velocity that is controlled by the medium. Varying the frequency and intensity of the sound waves will not affect the speed of propagation. The **ELASTICITY** and **DENSITY** of a medium are the two basic physical properties that govern the velocity of sound through the medium.

Elasticity is the ability of a strained body to recover its shape after deformation, as from a vibration or compression. The measure of elasticity of a body is the force it exerts to return to its original shape.

The *density* of a medium or substance is the mass per unit volume of the medium or substance. Raising the temperature of the medium (which decreases its density) has the effect of increasing the velocity of sound through the medium.

The velocity of sound in an elastic medium is expressed by the formula:

$$v = \sqrt{\frac{E}{d}}$$

Even though solids such as steel and glass are far more dense than air, their elasticity's are so much greater that the velocities of sound in them are 15 times greater than the velocity of sound in air. Using elasticity as a rough indication of the speed of sound in a given medium, we can state as a general rule that *sound travels faster in harder materials* (such as steel), *slower in liquids*, and *slowest in gases*. Density has the opposite effect on the velocity of sound, that is, with other factors constant, a denser material (such as lead) passes sound slower.

At a given temperature and atmospheric pressure, all sound waves travel in air at the same speed. Thus the velocity that sound will travel through air at 32° F (0° C) is 1,087 feet per second. But for practical purposes, the speed of sound in air may be considered as 1,100 feet per second. Table 1-1 gives a comparison of the velocity of sound in various mediums.

Table 1-1.—Comparison of Velocity of Sound in Various Mediums

| MEDIUM | TEMPERATURE | | VELOCITY (FT/SEC) |
|----------------|-------------|----|----------------------|
| | °F | °C | |
| AIR | 32 | 0 | 1,087 |
| AIR | 68 | 20 | 1,127 |
| ALUMINUM | 68 | 20 | 16,700 |
| CARBON DIOXIDE | 32 | 0 | 856 |
| FRESH WATER | 32 | 0 | 4,629 |
| FRESH WATER | 68 | 20 | 4,805 |
| HYDROGEN | 32 | 0 | 4,219 |
| LEAD | 32 | 20 | 4,030 |
| SALT WATER | 32 | 0 | 4,800 |
| SALT WATER | 68 | 20 | 4,953 |
| STEEL | 32 | 0 | 16,410 |
| STEEL | 68 | 20 | 16,850 |

Q25. How does density and temperature affect the velocity of sound?

ACOUSTICS

The science of sound is called ACOUSTICS. This subject could fill volumes of technical books, but we will only scratch the surface in this chapter. We will present important points that you will need for a better understanding of sound waves.

Acoustics, like sound, relates to the sense of hearing. It also deals with the production, control, transmission, reception, and the effects of sound. For the present, we are concerned only with the last relationship—the effects of sound. These same effects will be used throughout your study of wave propagation.

Echo

An ECHO is the reflection of the original sound wave as it bounces off a distant surface. Just as a rubber ball bounces back when it is thrown against a hard surface, sound waves also bounce off most surfaces. As you have learned from the study of the law of conservation of energy, a rubber ball never bounces back with as much energy as the initial bounce. Similarly, a reflected sound wave is not as loud as the original sound wave. In both cases, some of the energy is absorbed by the reflecting surface. Only a portion of the original sound is reflected, and only a portion of the reflected sound returns to the listener. For this reason, an echo is never as loud as the original sound.

Sound reflections (echoes) have many applications in the Navy. The most important of these applications can be found in the use of depth finding equipment (the fathometer) and sonar. The fathometer sends sound-wave pulses from the bottom of the ship and receives echoes from the ocean floor to indicate the depth of the ocean beneath the ship. The sonar transmits a pulse of sound energy and receives the echo to indicate range and bearing of objects or targets in the ocean depths.

Refraction

When sound waves traveling at different velocities pass obliquely (at an angle) from one medium into another, the waves are refracted; that is, their line of travel is bent. Refraction occurs gradually when one part of a sound wave is traveling faster than the other parts. For example, the wind a few feet above

the surface of the earth has a greater velocity than that near the surface because friction retards the lower layers (see figure 1-16). The velocity of the wind is added to the velocity of the sound through the air. The result is that the upper portion of the sound wave moves faster than the lower portion and causes a gradual change in the direction of travel of the wave. Refraction causes sound to travel farther with the wind than against it.

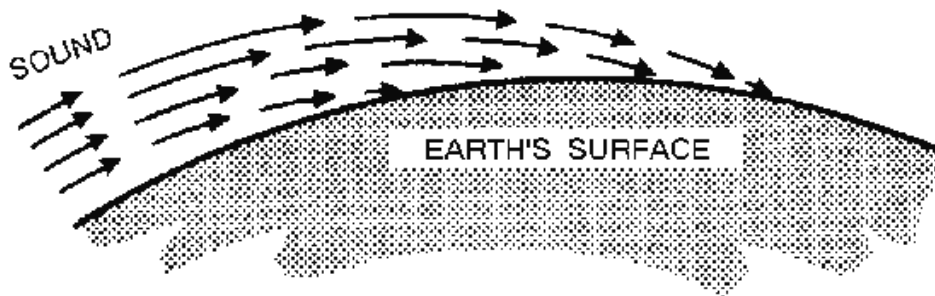

Figure 1-16.—Refraction of sound.

Reverberation

In empty rooms or other confined spaces, sound may be reflected several times to cause what is known as reverberation. REVERBERATION is the multiple reflections of sound waves. Reverberations seem to prolong the time during which a sound is heard. Examples of this often occur in nature. For instance, the discharge of lightning causes a sharp, quick sound. By the time this sound has reached the ears of a distant observer, it is usually drawn out into a prolonged roar by reverberations that we call thunder. A similar case often arises with underwater sound equipment. Reverberations from nearby points may continue for such a long time that they interfere with the returning echoes from targets.

Interference

Any disturbance, man-made or natural, that causes an undesirable response or the degradation of a wave is referred to as INTERFERENCE.

Two sound waves moving simultaneously through the same medium will advance independently, each producing a disturbance as if the other were not present. If the two waves have the same frequency—in phase with each other—and are moving in the same direction, they are additive and are said to interfere constructively. If the two waves have the same frequency and are moving in the same direction, but out of phase with each other, they are subtractive and are said to interfere destructively. If these two subtractive waves have equal amplitudes, the waves cancel each other. This addition or subtraction of waves is often called interference.

Resonance

At some time during your life you probably observed someone putting his or her head into an empty barrel or other cavity and making noises varying in pitch. When that person's voice reached a certain pitch, the tone produced seemed much louder than the others. The reason for this phenomenon is that at that a certain pitch the frequency of vibrations of the voice matched the resonant (or natural) frequency of the cavity. The resonant frequency of a cavity is the frequency at which the cavity body will begin to vibrate and create sound waves. When the resonant frequency of the cavity was reached, the sound of the voice was reinforced by the sound waves created by the cavity, resulting in a louder tone.

This phenomenon occurs whenever the frequency of vibrations is the same as the natural frequency of a cavity, and is called RESONANCE.

Noise

The most complex sound wave that can be produced is noise. Noise has no tonal quality. It distracts and distorts the sound quality that was intended to be heard. NOISE is generally an unwanted disturbance caused by spurious waves originating from man-made or natural sources, such as a jet breaking the sound barrier, or thunder.

Q26. What term is used in describing the science of sound?

Q27. A sound wave that is reflected back toward the source is known as what type of sound?

Q28. What is the term for multiple reflections of sound waves?

Q29. A cavity that vibrates at its natural frequency produces a louder sound than at other frequencies. What term is used to describe this phenomenon?

Q30. What do we call a disturbance that distracts or distorts the quality of sound?

LIGHT WAVES

Technicians maintain equipment that use frequencies from one end of the electromagnetic spectrum to the other—from low-frequency radio waves to high-frequency X-rays and cosmic rays. Visible light is a small but very important part of this electromagnetic spectrum.

Most of the important terms that pertain to the behavior of waves, such as reflection, refraction, diffraction, etc., were discussed earlier in this chapter. We will now discuss how these terms are used in understanding light and light waves. The relationship between light and light waves (rays) is the same as sound and sound waves.

Light is a form of energy. It can be produced by various means (mechanical, electrical, chemical, etc.). We can see objects because the light rays they give off or reflect reach our eyes. If the object is the source of light energy, it is called luminous. If the object is not the source of light but reflects light, it is called an illuminated body.

PROPAGATION OF LIGHT

The exact nature of light is not fully understood, although scientists have been studying the subject for many centuries. Some experiments seem to show that light is composed of tiny particles, and some suggest that it is made up of waves.

One theory after another attracted the approval and acceptance of physicists. Today, some scientific phenomena can be explained only by the wave theory and others only by the particle theory. Physicists, constantly searching for some new discovery that would bring these two theories into agreement, gradually have come to accept a theory that combines the principles of the two theories.

According to the view now generally accepted, light is a form of electromagnetic radiation; that is, light and similar forms of radiation are made up of moving electric and magnetic fields. These two fields will be explained thoroughly later in this chapter.

ELECTROMAGNETIC THEORY OF LIGHT

James Clark Maxwell, a brilliant Scottish scientist Of the middle 19th century, showed, by constructing an oscillating electrical circuit, that electromagnetic waves could move through empty space. Light eventually was proved to be electromagnetic.

Current light theory says that light is made up of very small packets of electromagnetic energy called PHOTONS (the smallest unit of radiant energy). These photons move at a constant speed in the medium through which they travel. Photons move at a faster speed through a vacuum than they do in the atmosphere, and at a slower speed through water than air.

The electromagnetic energy of light is a form of electromagnetic radiation. Light and similar forms of radiation are made up of moving electric and magnetic forces and move as waves. Electromagnetic waves move in a manner similar to the waves produced by the pebble dropped in the pool of water discussed earlier in this chapter. The transverse waves of light from a light source spread out in expanding circles much like the waves in the pool. However, the waves in the pool are very slow and clumsy in comparison with light, which travels approximately 186,000 miles per second.

Light radiates from its source in all directions until absorbed or diverted by some substance (fig. 1-17). The lines drawn from the light source (a light bulb in this instance) to any point on one of these waves indicate the direction in which the waves are moving. These lines, called radii of the spheres, are formed by the waves and are called LIGHT RAYS.

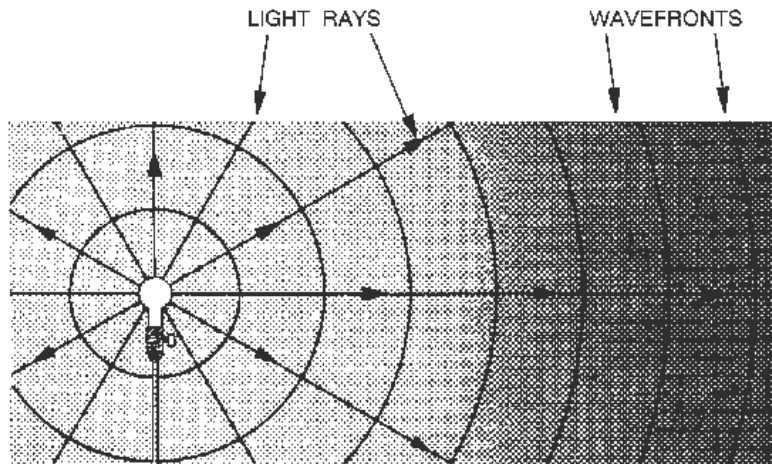

Figure 1-17.—Waves and radii from a nearby light source.

Although single rays of light do not exist, light "rays" as used in illustrations are a convenient method used to show the direction in which light is traveling at any point.

A large volume of light is called a beam; a narrow beam is called a pencil; and the smallest portion of a pencil is called a light ray. A ray of light, can be illustrated as a straight line. This straight line drawn from a light source will represent an infinite number of rays radiating in all directions from the source.

Q31. What are three means of producing light?

Q32. What is the smallest unit of radiant energy?

FREQUENCIES AND WAVELENGTHS

Compared to sound waves, the frequency of light waves is very high and the wavelength is very short. To measure these wavelengths more conveniently, a special unit of measure called an **ANGSTROM UNIT**, or more usually, an **ANGSTROM** (\AA) was devised. Another common unit used to measure these waves is the **millimicron** ($m\mu$), which is one millionth of a millimeter. One $m\mu$ equals ten angstroms. One angstrom equals $1055^{-10}m$.

Q33. What unit is used to measure the different wavelengths of light?

FREQUENCIES AND COLOR

For our discussion of light wave waves, we will use the millimicron measurement. The wavelength of a light determines the color of the light. Figure 1-18 indicates that light with a wavelength of 700 millimicrons is red, and that light with a wavelength of 500 millimicrons is blue-green. This illustration shows approximate wavelengths of the different colors in the visible spectrum. In actual fact, the color of light depends on its frequency, not its wavelength. However, light is measured in wavelengths.

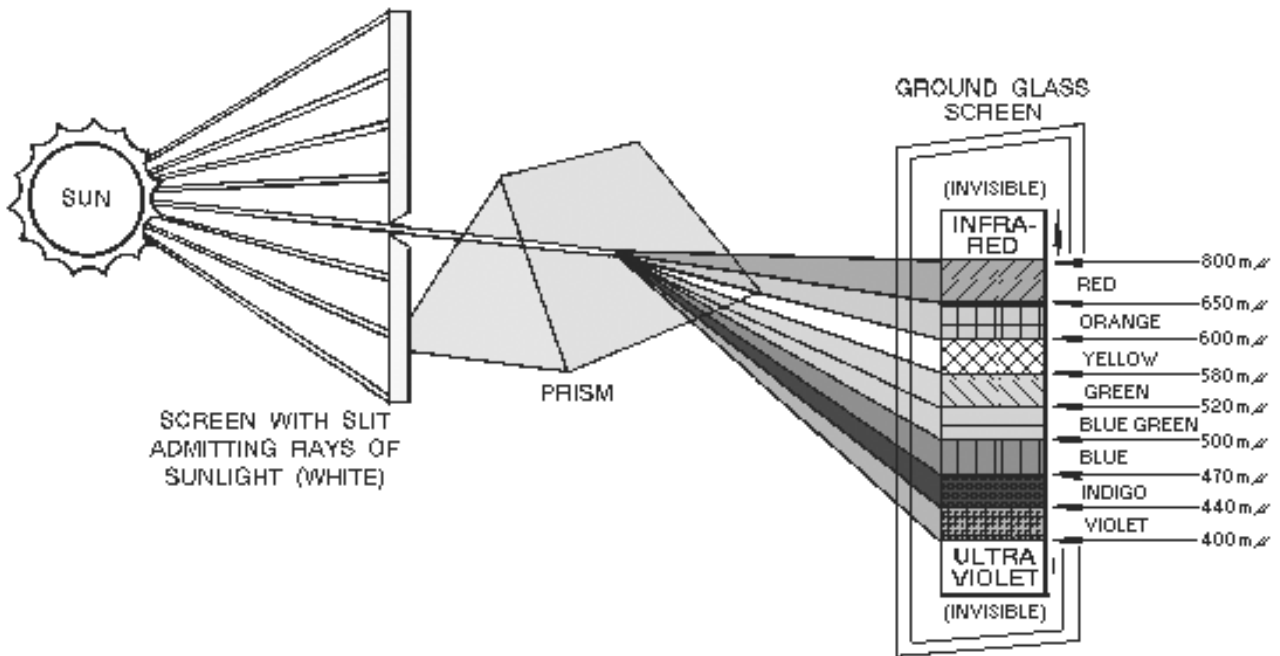

Figure 1-18.—Use of a prism to split white light into different colors.

When the wavelength of 700 millimicrons is measured in a medium such as air, it produces the color red, but the same wave measured in a different medium will have a different wavelength. When red light which has been traveling in air enters glass, it loses speed. Its wavelength becomes shorter or compressed, but it continues to be red. This illustrates that the color of light depends on frequency and not on wavelength. The color scale in figure 1-18 is based on the wavelengths in air.

When a beam of white light (sunlight) is passed through a **PRISM**, as shown in figure 1-18, it is refracted and dispersed (the phenomenon is known as **DISPERSION**) into its component wavelengths. Each of these wavelengths causes a different reaction of the eye, which sees the various colors that compose the visible spectrum. The visible spectrum is recorded as a mixture of red, orange, yellow, green, blue, indigo, and violet. White light results when the **PRIMARIES** (red, green, and blue) are mixed

together in overlapping beams of light. (NOTE: These are not the primaries used in mixing pigments, such as in paint.) Furthermore, the COMPLEMENTARY or SECONDARY colors (magenta, yellow, and cyan) may be shown with equal ease by mixing any two of the primary colors in overlapping beams of light. Thus, red and green light mixed in equal intensities will make yellow light; green and blue will produce cyan (blue-green light); and blue and red correctly mixed will produce magenta (a purplish red light).

LIGHT AND COLOR

All objects absorb some of the light that falls on them. An object appears to be a certain color because it absorbs all of the light waves except those whose frequency corresponds to that particular color. Those waves are reflected from the surface, strike your eye, and cause you to see the particular color. The color of an object therefore depends on the frequency of the electromagnetic wave reflected.

LUMINOUS BODIES

Certain bodies, such as the sun, a gas flame, and an electric light filament, are visible because they are light sources. They are called SELF-LUMINOUS bodies. Objects other than self-luminous bodies become visible only when they are in the presence of light from luminous bodies.

Most NONLUMINOUS bodies are visible because they diffuse or reflect the light that falls on them. A good example of a nonluminous diffusing body is the moon, which shines only because the sunlight falling onto its surface is diffused.

Black objects do not diffuse or reflect light. They are visible only when outlined against a background of light from a luminous or diffusing body.

PROPERTIES OF LIGHT

When light waves, which travel in straight lines, encounter any substance, they are either transmitted, refracted, reflected, or absorbed. This is illustrated in figure 1-19. When light strikes a substance, some absorption and some reflection always take place. No substance completely transmits, reflects, or absorbs all of the light rays that reach its surface. Substances that transmit almost all the light waves that fall upon them are said to be TRANSPARENT. A transparent substance is one through which you can see clearly. Clear glass is transparent because it transmits light rays without diffusing them (view A of figure 1-20). There is no known perfectly transparent substance, but many substances are nearly so. Substances through which some light rays can pass but through which objects cannot be seen clearly because the rays are diffused are called TRANSLUCENT (view B of figure 1-20). The frosted glass of a light bulb and a piece of oiled paper are examples of translucent materials. Substances that do not transmit any light rays are called OPAQUE (view C of figure 1-20). Opaque substances can either reflect or absorb all of the light rays that fall upon them.

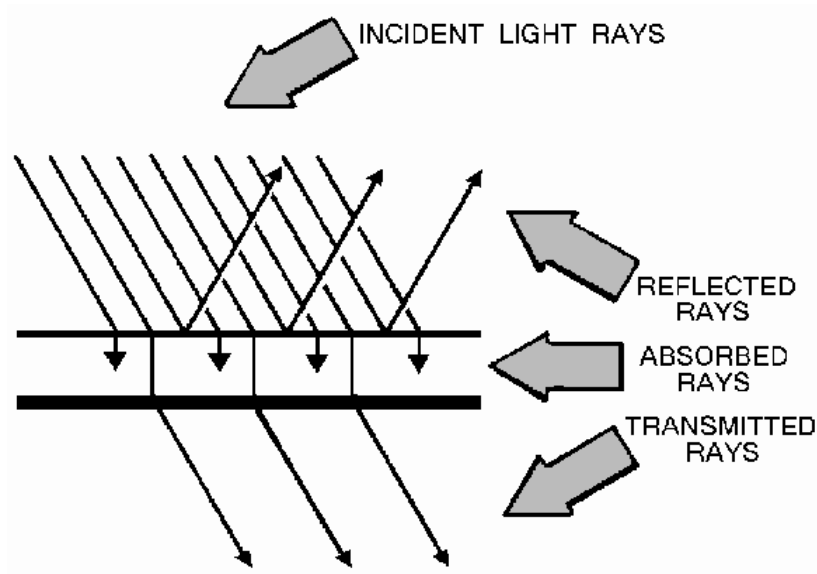

Figure 1-19.—Light waves reflected, absorbed, and transmitted.

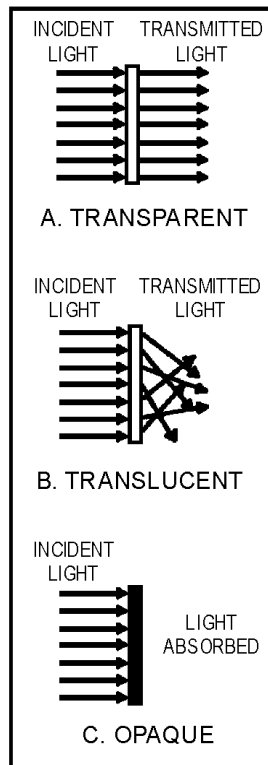

Figure 1-20.—Transparent, translucent, and opaque substances.

Q34. What are the three primary colors of light?

Q35. What are the three secondary colors of light?

Q36. *White light falls upon a dull, rough, dark-brown object. Will the light primarily be reflected, diffused, or absorbed by the object?*

Q37. *What color will be emitted by a dull, rough, black object when white light falls upon it?*

Q38. *A substance that transmits light but through which an object cannot be seen clearly is known as what kind of substance?*

Speed of Light

You probably have heard people say, "quick as lightning" or "fast as light" to describe rapid motion; nevertheless, it is difficult to realize how fast light actually travels. Not until recent years have scientists been able to measure accurately the speed of light.

Prior to the middle 17th century, scientists thought that light required no time at all to pass from the source to the observer. Then in 1675, Ole Roemer, a Danish astronomer, discovered that light travels approximately 186,000 miles per second in space. At this velocity, a light beam can circle the earth $7\frac{1}{2}$ times in one second.

The speed of light depends on the medium through which the light travels. In empty space, the speed is 186,000 (1.86×10^5) miles per second. It is almost the same in air. In water, it slows down to approximately 140,000 (1.4×10^5) miles per second. In glass, the speed of light is 124,000 (1.24×10^5) miles per second. In other words, the speed of light decreases as the density of the substance through which the light passes increases.

The velocity of light, which is the same as the velocity of other electromagnetic waves, is considered to be constant, at 186,000 miles per second. If expressed in meters, it is 300,000,000 meters per second.

Reflection of Light

Light waves obey the law of reflection in the same manner as other types of waves. Consider the straight path of a light ray admitted through a narrow slit into a darkened room. The straight path of the beam is made visible by illuminated dust particles suspended in the air. If the light beam is made to fall onto the surface of a mirror or other reflecting surface, however, the direction of the beam changes sharply. The light can be reflected in almost any direction depending on the angle at which the mirror is held.

As shown earlier in figure 1-9, if a light beam strikes a mirror, the angle at which the beam is reflected depends on the angle at which it strikes the mirror. The beam approaching the mirror is the INCIDENT or striking beam, and the beam leaving the mirror is the REFLECTED beam.

The term "reflected light" simply refers to light waves that are neither transmitted nor absorbed, but are thrown back from the surface of the medium they encounter.

You will see this application used in our discussion of radio waves (chapter 2) and antennas (chapter 4).

Q39. *At what speed does light travel?*

Refraction of Light

The change of direction that occurs when a ray of light passes from one transparent substance into another of different density is called refraction. Refraction is due to the fact that light travels at various

speeds in different transparent substances. For example, water never appears as deep as it really is, and objects under water appear to be closer to the surface than they really are. A bending of the light rays causes these impressions.

Another example of refraction is the apparent bending of a spoon when it is immersed in a cup of water. The bending seems to take place at the surface of the water, or exactly at the point where there is a change of density. Obviously, the spoon does not bend from the pressure of the water. The light forming the image of the spoon is bent as it passes from the water (a medium of high density) to the air (a medium of comparatively low density).

Without refraction, light waves would pass in straight lines through transparent substances without any change of direction. Refer back to figure 1-10, which shows refraction of a wave. As you can see, all rays striking the glass at any angle other than perpendicular are refracted. However, the perpendicular ray, which enters the glass normal to the surface, continues through the glass and into the air in a straight line no refraction takes place.

Diffusion of Light

When light is reflected from a mirror, the angle of reflection of each ray equals the angle of incidence. When light is reflected from a piece of plain white paper, however, the reflected beam is scattered, or DIFFUSED, as shown in figure 1-21. Because the surface of the paper is not smooth, the reflected light is broken up into many light beams that are reflected in all directions.

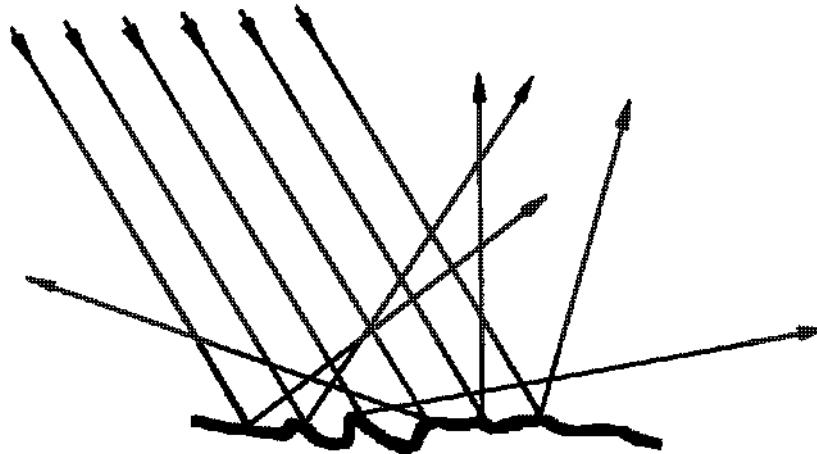

Figure 1-21.—Diffusion of light.

Absorption of Light

You have just seen that a light beam is reflected and diffused when it falls onto a piece of white paper. If a light beam falls onto a piece of black paper, the black paper absorbs most of the light rays and very little light is reflected from the paper. If the surface on which the light beam falls is perfectly black, there is no reflection; that is, the light is totally absorbed. No matter what kind of surface light falls on, however, some of the light is absorbed.

Q40. A light wave enters a sheet of glass at a perfect right angle to the surface. Is the majority of the wave reflected, refracted, transmitted, or absorbed?

Q41. When light strikes a piece of white paper, the light is reflected in all directions. What do we call this scattering of light?

COMPARISON OF LIGHT WAVES WITH SOUND WAVES

There are two main differences between sound waves and light waves. The first difference is in velocity. Sound waves travel through air at the speed of approximately 1,100 feet per second; light waves travel through air and empty space at a speed of approximately 186,000 miles per second. The second difference is that sound is composed of longitudinal waves (alternate compressions and expansions of matter) and light is composed of transverse waves in an electromagnetic field.

Although both are forms of wave motion, sound requires a solid, liquid, or gaseous medium; whereas light travels through empty space. The denser the medium, the greater the speed of sound. The opposite is true of light. Light travels approximately one-third slower in water than in air. Sound travels through all substances, but light cannot pass through opaque materials.

Frequency affects both sound and light. A certain range of sound frequencies produces sensations that you can hear. A slow vibration (low frequency) in sound gives the sensation of a low note. A more rapid sound vibration (higher frequency) produces a higher note. Likewise, a certain range of light frequencies produces sensations that you can see. Violet light is produced at the high-frequency end of the light spectrum, while red light is produced at the low-frequency end of the light spectrum. A change in frequency of sound waves causes an audible sensation—a difference in pitch. A change in the frequency of a light wave causes a visual sensation—a difference in color.

For a comparison of light waves with sound waves, see table 1-2.

Table 1-2.—Comparison of Light Waves and Sound Waves

| | SOUND WAVES | LIGHT WAVES |
|--|--|--|
| VELOCITY IN AIR | APPROXIMATELY 1,100 FEET PER SECOND | APPROXIMATELY 186,000 MILES PER SECOND |
| FORM | A FORM OF WAVE MOTION | A FORM OF WAVE MOTION |
| WAVE COMPOSITION | LONGITUDINAL | TRANSVERSE |
| TRANSMITTING MEDIUM | ALL SUBSTANCES | EMPTY SPACE AND ALL SUBSTANCES EXCEPT OPAQUE MATERIALS |
| RELATION OF TRANSMITTING MEDIUM VELOCITY TO VELOCITY | THE DENSER THE MEDIUM, THE GREATER THE SPEED | THE DENSER THE MEDIUM, THE SLOWER THE SPEED |
| SENSATIONS PRODUCED | HEARING | SEEING |
| VARIATIONS IN SENSATIONS PRODUCED | A LOW FREQUENCY CAUSES A LOW NOTE; A HIGH FREQUENCY, A HIGH NOTE | A LOW FREQUENCY CAUSES RED LIGHT; A HIGH FREQUENCY, VIOLET LIGHT |

Q42. What three examples of electromagnetic energy are mentioned in the text?

Q43. What is the main difference between the bulk of the electromagnetic spectrum and the visual spectrum?

ELECTROMAGNETIC SPECTRUM

Light is one kind of electromagnetic energy. There are many other types, including heat energy and radio energy. The only difference between the various types of electromagnetic energy is the frequency of their waves (rate of vibration). The term SPECTRUM is used to designate the entire range of electromagnetic waves arranged in order of their frequencies. The VISIBLE SPECTRUM contains only those waves which stimulate the sense of sight. You, as a technician, might be expected to maintain equipment that uses electromagnetic waves within, above, and below the visible spectrum.

There are neither sharp dividing lines nor gaps in the ELECTROMAGNETIC SPECTRUM. Figure 1-22 illustrates how portions of the electromagnetic spectrum overlap. Notice that only a small portion of the electromagnetic spectrum contains visible waves, or light, which can be seen by the human eye.

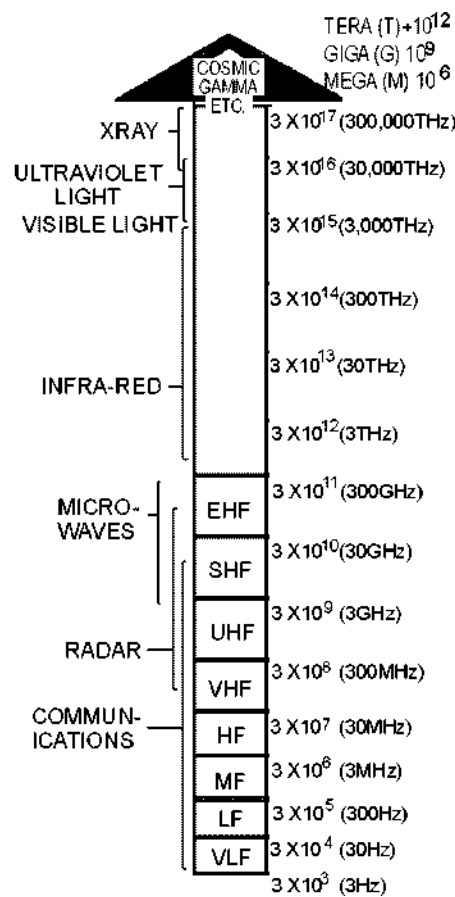

Figure 1-22.—Electromagnetic spectrum.

ELECTROMAGNETIC WAVES

In general, the same principles and properties of light waves apply to the communications electromagnetic waves you are about to study. The electromagnetic field is used to transfer energy (as communications) from point to point. We will introduce the basic ANTENNA as the propagation source of these electromagnetic waves.

THE BASIC ANTENNA

The study of antennas and electromagnetic wave propagation is essential to a complete understanding of radio communication, radar, loran, and other electronic systems. Figure 1-23 shows a simple radio communication system. In the illustration, the transmitter is an electronic device that generates radio-frequency energy. The energy travels through a transmission line (we will discuss this in chapter 3) to an antenna. The antenna converts the energy into radio waves that radiate into space from the antenna at the speed of light. The radio waves travel through the atmosphere or space until they are either reflected by an object or absorbed. If another antenna is placed in the path of the radio waves, it absorbs part of the waves and converts them to energy. This energy travels through another transmission line and is fed to a receiver. From this example, you can see that the requirements for a simple communications system are (1) transmitting equipment, (2) transmission line, (3) transmitting antenna, (4) medium, (5) receiving antenna, and (6) receiving equipment.

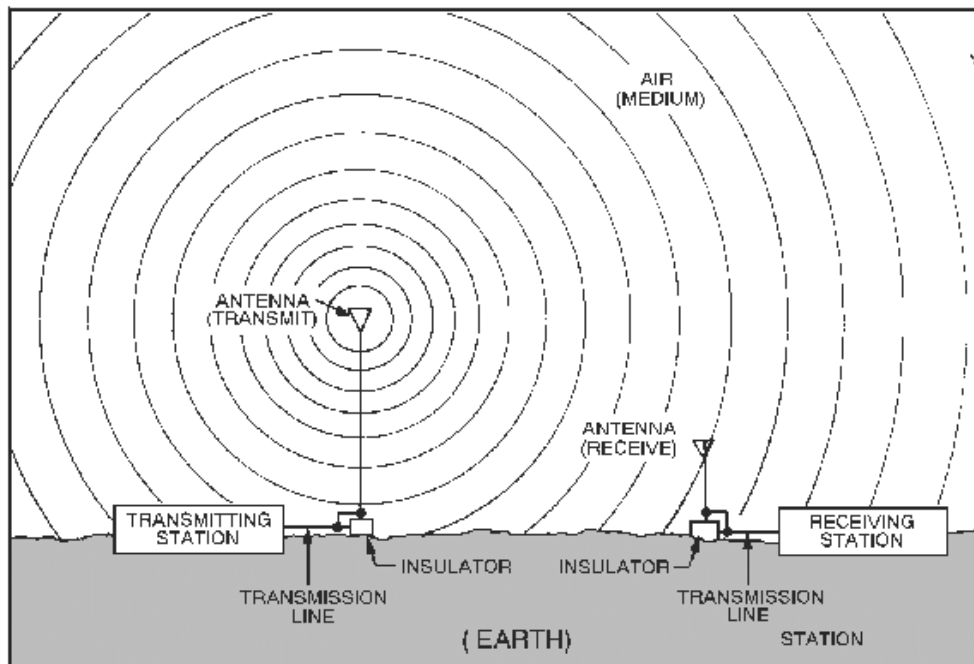

Figure 1-23.—Simple radio communication system.

An antenna is a conductor or a set of conductors used either to radiate electromagnetic energy into space or to collect this energy from space. Figure 1-24 shows an antenna. View A is a drawing of an actual antenna; view B is a cut-away view of the antenna; and view C is a simplified diagram of the antenna.

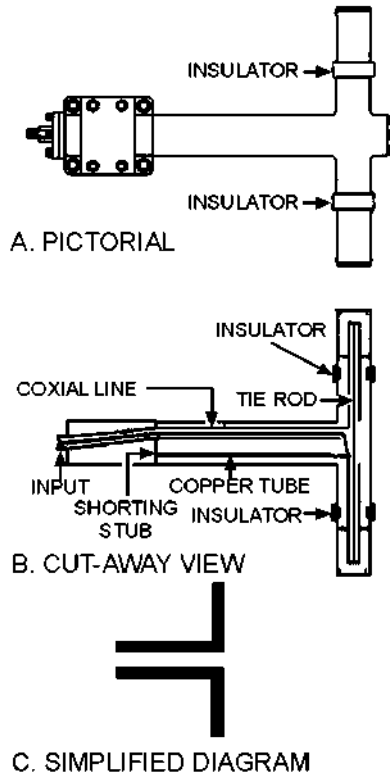

Figure 1-24.—Antenna.

COMPONENTS OF THE ELECTROMAGNETIC WAVE

An electromagnetic wave consists of two primary components—an **ELECTRIC FIELD** and a **MAGNETIC FIELD**. The electric field results from the force of voltage, and the magnetic field results from the flow of current.

Although electromagnetic fields that are radiated are commonly considered to be waves, under certain circumstances their behavior makes them appear to have some of the properties of particles. In general, however, it is easier to picture electromagnetic radiation in space as horizontal and vertical lines of force oriented at right angles to each other. These lines of force are made up of an electric field (E) and a magnetic field (H), which together make up the electromagnetic field in space.

The electric and magnetic fields radiated from an antenna form the electromagnetic field. This field is responsible for the transmission and reception of electromagnetic energy through free space. An antenna, however, is also part of the electrical circuit of a transmitter or a receiver and is equivalent to a circuit containing inductance, capacitance, and resistance. Therefore, the antenna can be expected to display definite voltage and current relationships with respect to a given input. A current through the antenna produces a magnetic field, and a charge on the antenna produces an electric field. These two fields combine to form the **INDUCTION** field. To help you gain a better understanding of antenna theory, we must review some basic electrical concepts. We will review voltage and its electric field, current and its magnetic field, and their relationship to propagation of electrical energy.

Q44. What are the two components (fields) that make up the electromagnetic wave?

Q45. What do we call a conductor (or set of conductors) that radiates electromagnetic energy into space?

Electric Field

Around every electrically charged object is a force field that can be detected and measured. This force field can cause electric charges to move in the field. When an object is charged electrically, there is either a greater or a smaller concentration of electrons than normal. Thus, a difference of potential exists between a charged object and an uncharged object. An electric field is, therefore, associated with a difference of potential, or a voltage.

This invisible field of force is commonly represented by lines that are drawn to show the paths along which the force acts. The lines representing the electric field are drawn in the direction that a single positive charge would normally move under the influence of that field. A large electric force is shown by a large concentration of lines; a weak force is indicated by a few lines.

When a capacitor is connected across a source of voltage, such as a battery, it is charged by a particular amount, depending on the voltage and the value of capacitance. (See figure 1-25.) Because of the emf (electromotive force) of the battery, negative charges flow to the lower plate, leaving the upper plate positively charged. Along with the growth of charge, the electric field is also building up. The flux lines are directed from the positive to the negative charges and at right angles to the plates. When the capacitor is fully charged, the voltage of the capacitor is equal to the voltage of the source and opposite in polarity. The charged capacitor stores the energy in the form of an electric field. It can be said, therefore, that an electric field indicates voltage.

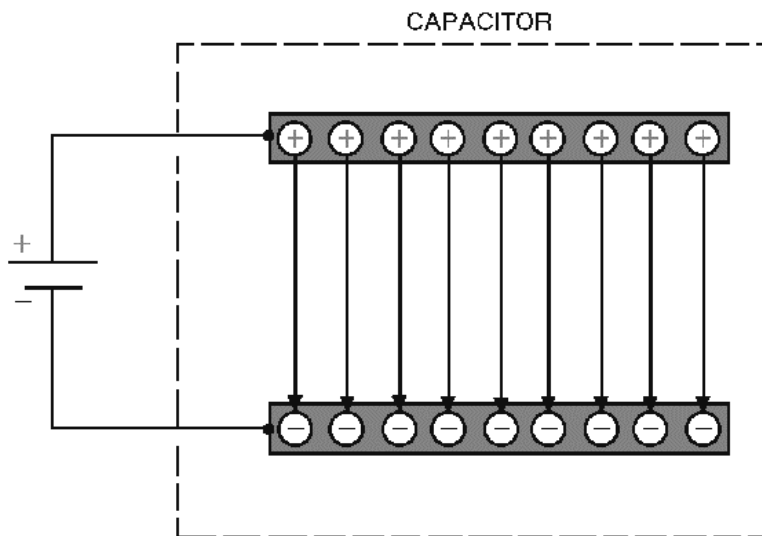

Figure 1-25.—Electric fields between plates.

If the two plates of the capacitor are spread farther apart, the electric field must curve to meet the plates at right angles (fig. 1-26). The straight lines in view A of figure 1-26 become arcs in view B, and approximately semicircles in view C, where the plates are in a straight line. Instead of flat metal plates, as in the capacitor, the two elements can take the form of metal rods or wires and form the basic antenna.

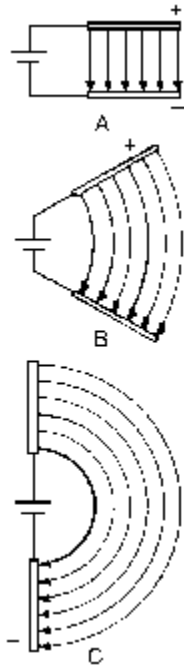

Figure 1-26.—Electric fields between plates at different angles.

In figure 1-27, two rods replace the plates of the capacitor, and the battery is replaced by an ac source generating a 60-hertz signal. On the positive alternation of the 60-hertz generator, the electric field extends from the positively charged rod to the negatively charged rod, as shown. On the negative alternation, the charge is reversed. The previous explanation of electrons moving from one plate to the other of the capacitor in figure 1-25 can also be applied to the rods in figure 1-27.

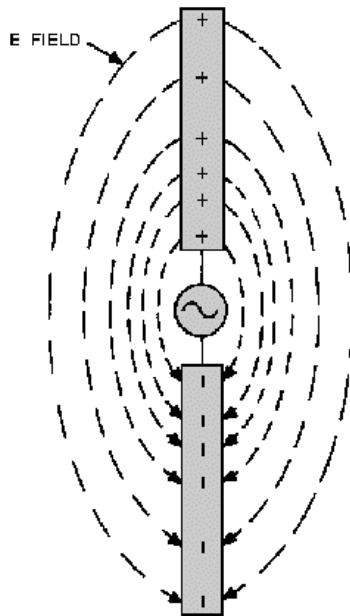

Figure 1-27.—Electric fields between elements.

The polarity of charges and the direction of the electric fields will reverse polarity and direction periodically at the frequency of the voltage source. The electric field will build up from zero to maximum in one direction and then collapse back to zero. Next, the field will build up to maximum in the opposite direction and then collapse back to zero. This complete reversal occurs during a single cycle of the source voltage. The HALF-WAVE DIPOLE ANTENNA (two separate rods in line as illustrated in figure 1-27) is the fundamental element normally used as a starting point of reference in any discussion concerning the radiation of electromagnetic energy into space. If rf energy from the ac generator (or transmitter) is supplied to the element of an antenna, the voltage across the antenna lags the current by 90 degrees. The antenna acts as if it were a capacitor.

Magnetic Field

When current flows through a conductor, a magnetic field is set up in the area surrounding the conductor. In fact, any moving electrical charge will create a magnetic field. The magnetic field is a region in space where a magnetic force can be detected and measured. There are two other fields involved—an INDUCTION FIELD, which exists close to the conductor carrying the current, and the RADIATION FIELD, which becomes detached from the current-carrying rod and travels through space.

To represent the magnetic field, lines of force are again used to illustrate the energy. Magnetic lines are not drawn between the rods, nor between high- and low-potential points, as the E lines that were discussed earlier. Magnetic lines are created by the flow of current rather than the force of voltage. The magnetic lines of force, therefore, are drawn at right angles to the direction of current flow.

The magnetic fields that are set up around two parallel rods, as shown in figure 1-28 view A, are in maximum opposition. Rod 1 contains a current flowing from the generator, while rod 2 contains a current flowing toward the generator. As a result, the direction of the magnetic field surrounding rod 1 is opposite the direction of the magnetic field surrounding rod 2. This will cause cancellation of part or all of both magnetic fields with a resultant decrease in radiation of the electromagnetic energy. View B illustrates the fact that if the far ends of rods 1 and 2 are separated from each other while the rods are still connected to the generator at the near ends, more space, and consequently less opposition, will occur between the magnetic fields of the two rods. View C illustrates the fact that placing the rods in line makes the currents through both rods flow in the same direction. Therefore, the two magnetic fields are in the same direction; thus, maximum electromagnetic radiation into space can be obtained.

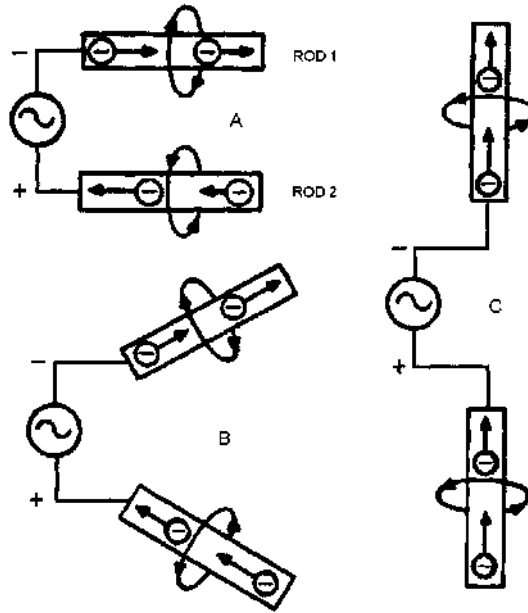

Figure 1-28.—Magnetic fields around elements.

Magnetic lines of force are indicated by the letter H and are called H lines. The direction of the magnetic lines may be determined by use of the left-hand rule for a conductor: If you grasp the conductor in your left hand with the thumb extended in the direction of the current flow, your fingers will point in the direction of the magnetic lines of force. In view C of figure 1-28, the direction of current flow is upward along both halves of the elements (conductors). The lines of magnetic force (flux) form concentric loops that are perpendicular to the direction of current flow. The arrowheads on the loops indicate the direction of the field. The left-hand rule is used to determine the direction of the magnetic field and is illustrated in figure 1-29. If the thumb of the left hand is extended in the direction of current flow and the fingers clenched, then the rough circles formed by the fingers indicate the direction of the magnetic field.

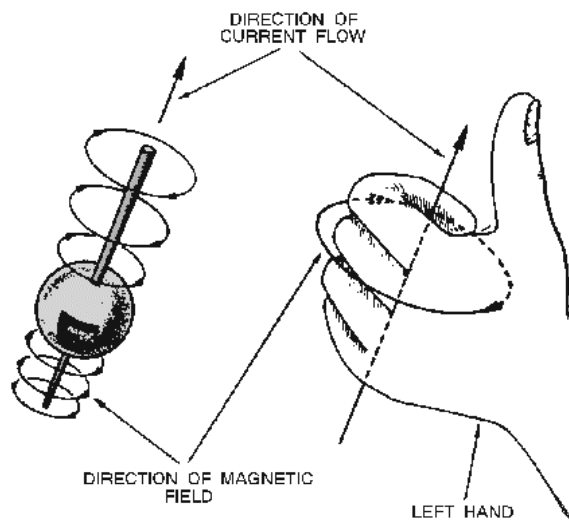

Figure 1-29.—Left-hand rule for conducting elements.

- Q46. What do we call the field that is created between two rods when a voltage is applied to them?
- Q47. When current flows through a conductor, a field is created around the conductor. What do we call this field?

Combined Electric and Magnetic Fields

The generator, shown in figure 1-30, provides the voltage, which creates an electric field, and current, which creates a magnetic field. This source voltage and current build up to maximum values in one direction during one half-cycle, and then build up to maximum values in the other direction during the next half-cycle. Both the electric and magnetic fields alternate from minimum through maximum values in synchronization with the changing voltage and current. The electric and magnetic fields reach their maximum intensity a quarter-cycle apart. These fields form the induction field. Since the current and voltage that produce these E and H fields are 90 degrees out of phase, the fields will also be 90 degrees out of phase.

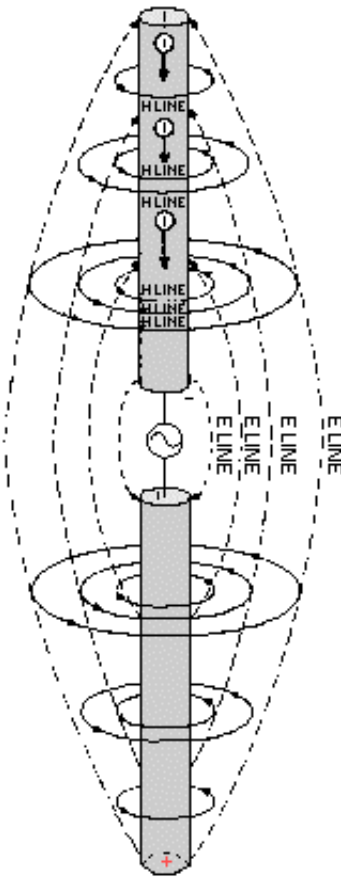

Figure 1-30.—Relationship of E-lines, and current flow.

- Q48. An induction field is created around a conductor when current flows through it. What do we call the field that detaches itself from the conductor and travels through space?

SUMMARY

Now that you have completed this chapter, let's review some of the new terms, concepts, and ideas you have learned. You should have a thorough understanding of these principles before moving on to chapter 2.

WAVE PROPAGATION is an invisible force that enables man to communicate over long distances. Wave transmission can take many forms, such as **LIGHT**, **SOUND**, and **RADIO**.

LIGHT is a form of wave motion that can be seen. Heat cannot normally be seen, but can be felt. Radio waves cannot be seen or felt.

WAVE MOTION can be seen in action by throwing a pebble into a pool of still water. The ripples that move toward the edge of the pool demonstrate the **PROPAGATION** theory.

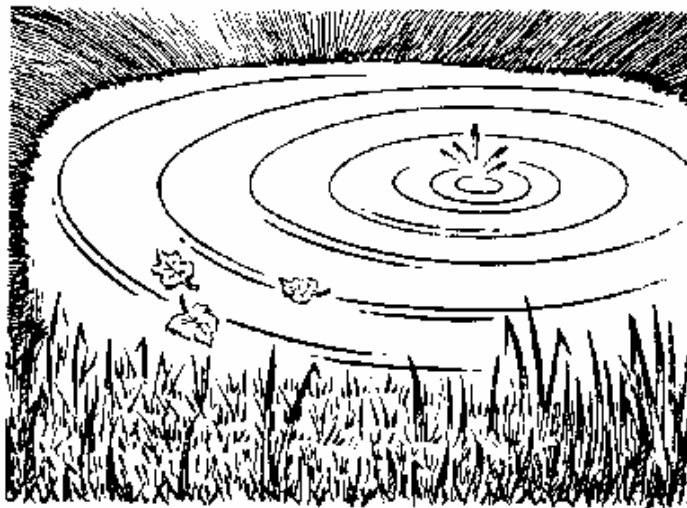

The **TRANSVERSE WAVE** is a type of wave motion. Radio, light, and heat waves are examples of transverse waves.

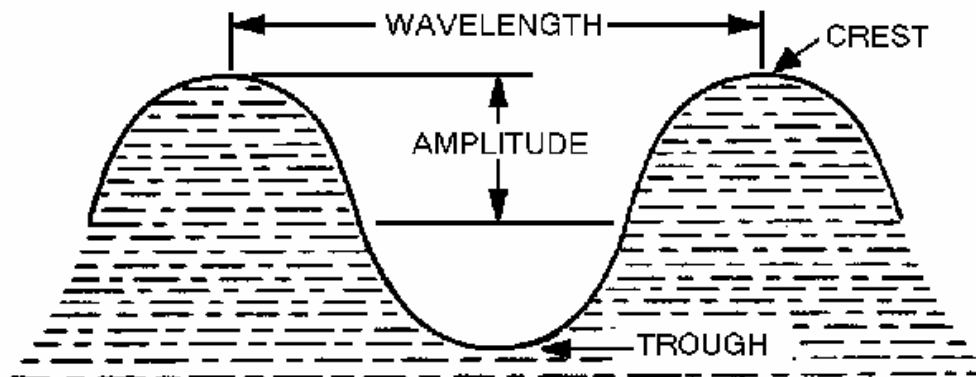

The **LONGITUDINAL WAVE** is another type of wave motion. The sound wave is the only example of a longitudinal wave given in this text.

SOURCE, MEDIUM, AND DETECTOR (RECEIVER) are the three requirements for all wave motion.

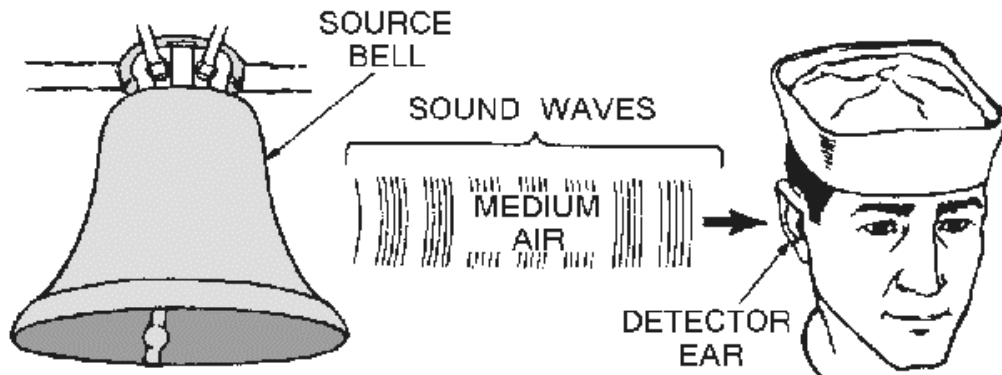

A **SOURCE** can be anything that emits or expends energy (waves).

The **MEDIUM** is the vehicle for carrying waves from one point to another. Water, air, metal, empty space, etc., are examples of a medium. Empty space is considered a medium for electro-magnetic waves but not a medium for sound waves.

The **SOUND DETECTOR** absorbs the waves emitted by the source. The human ear is an example of a detector.

HERTZ, which is abbreviated **Hz**, is used in lieu of "cycle per second" when referring to radio frequencies.

VELOCITY OF PROPAGATION is the speed (or rate) at which the crest of a wave moves through a medium. Velocity can be calculated by using the formula:

$$V = \lambda f$$

Where v is velocity of propagation and is expressed in feet (meters) per second, λ is the wavelength in feet (meters), and f is the frequency in hertz.

REFLECTION occurs when a wave strikes an object and bounces back (toward the source). The wave that moves from the source to the object is called the **INCIDENT WAVE**, and the wave that moves away from the object is called the **REFLECTED WAVE**.

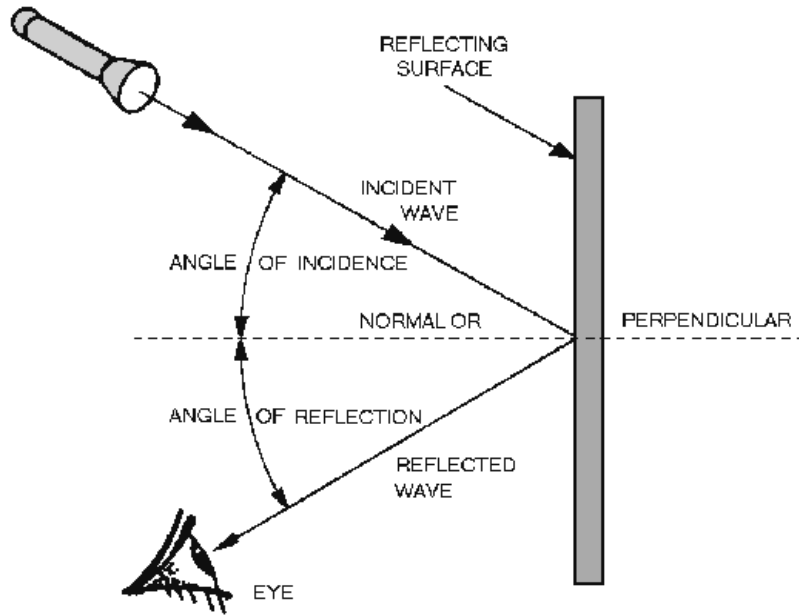

The **LAW OF REFLECTION** states:

The angle of incidence is equal to the angle of reflection.

REFRACTION occurs when a wave traveling through two different mediums passes through the **BOUNDARY** of the mediums and bends toward or away from the **NORMAL**.

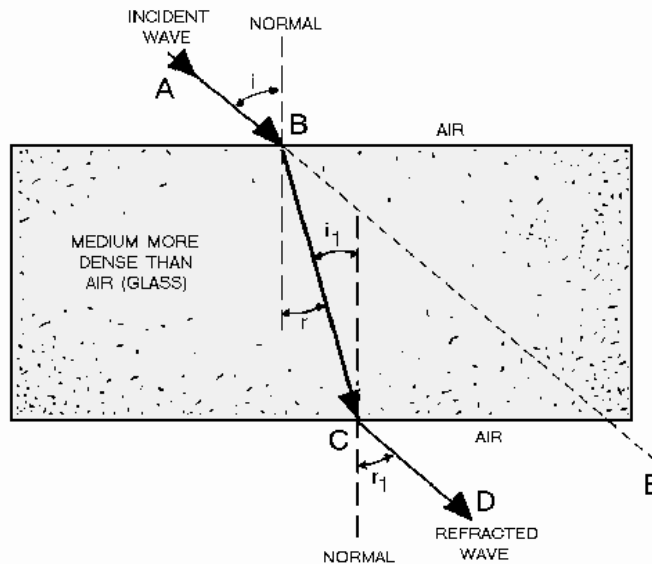

DIFFRACTION can account for the ability of the AM radio waves (due to their low frequency) to travel over a mountain, while FM and TV signals (due to their higher frequencies) are blocked.

The **DOPPLER EFFECT** is the apparent change in frequency of a source as it moves toward or away from a detector. It can affect the operation of equipment used to detect and measure wave energy.

SOUND can be audible to the human ear or it can be outside the hearing range.

NOISE AND TONES are the two general groups that broadly classify ALL sounds.



A MUSICAL NOTE



B NOISE

PITCH, INTENSITY, AND QUALITY are the three basic characteristics of sound. Pitch describes the frequency of sound. Intensity describes how much energy is transmitted. Quality enables us to distinguish one sound from another.

The **DENSITY** of a **MEDIUM, TEMPERATURE,** and **ATMOSPHERIC PRESSURE** affect the velocity of sound. If temperature, density, or pressure increases, the velocity of sound increases and vice versa.

ACOUSTICS is the science of sound and relates to the sense of hearing.

ECHO is an example of reflection. Sound echoes are used in sonar and depth finders to determine or measure the range of an object or the depth of the ocean bottom.

REVERBERATION is the multiple reflections of sound waves. The prolonged roar of thunder is caused by reverberations. With underwater sound equipment, reverberations of nearby objects may interfere with returning echoes from actual targets.

INTERFERENCE occurs when two waves move simultaneously through a medium. They can interfere constructively, destructively, or produce a resultant of zero.

RESONANCE occurs when an object vibrates (or resonates) at its natural frequency. When different frequencies are produced inside a cavity, the sound from the cavity sounds louder at its resonant frequency than at all other frequencies.

NOISE is any disturbance that distracts from or distorts the quality of sound.

A **PHOTON** is the smallest unit of radiant energy that makes up light waves and radio waves.

ANGSTROM (\AA) units are used for measuring the wavelength of light. One angstrom = 1055^{-10} m.

The **VISIBLE SPECTRUM** contains all the colors between infrared and ultraviolet. **INFRA-RED** and **ULTRA-VIOLET** are invisible to the human eye.

The **PRIMARY COLORS** of light are red, green, and blue. These primaries can be mixed to make any color between red and violet. If the three colors are mixed equally, they produce white light.

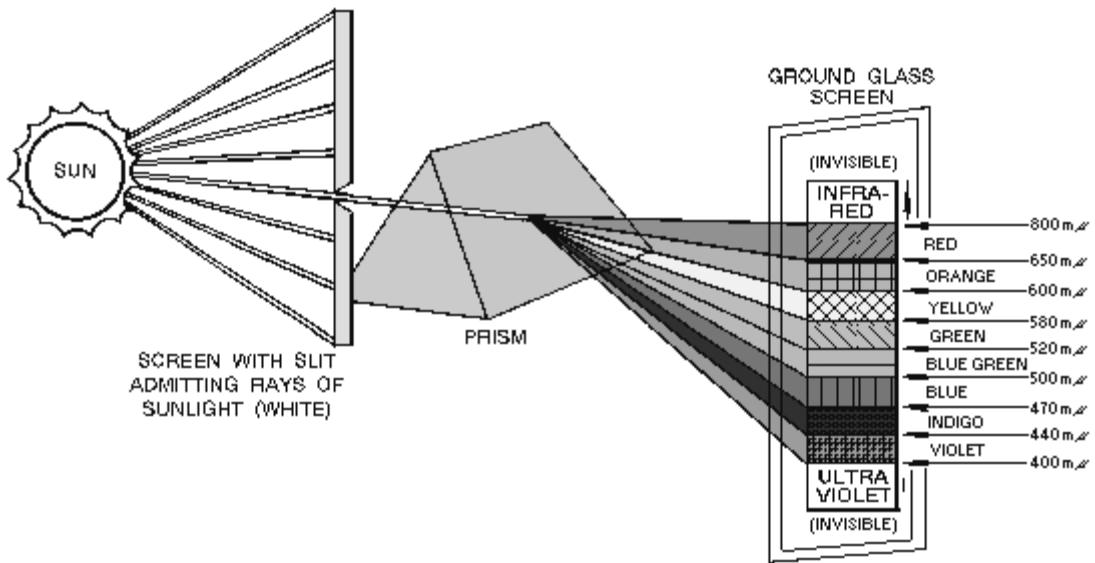

The **COMPLEMENTARY COLORS** of light are magenta, yellow, and cyan. They are produced by mixing any two of the primary colors together in overlapping beams.

The **SPEED OF LIGHT** in empty space is considered to be 186,000 miles per second (or 300,000,000 meters per second). This speed varies in different mediums, but the constant of 186,000 miles per second is always used as the speed of light.

The **ELECTROMAGNETIC SPECTRUM** is the complete range of electromagnetic frequencies from 3 kHz to beyond 300,000 THz. Audio frequencies (15 Hz-20 kHz) are not electromagnetic energy and are not included in the electromagnetic spectrum.

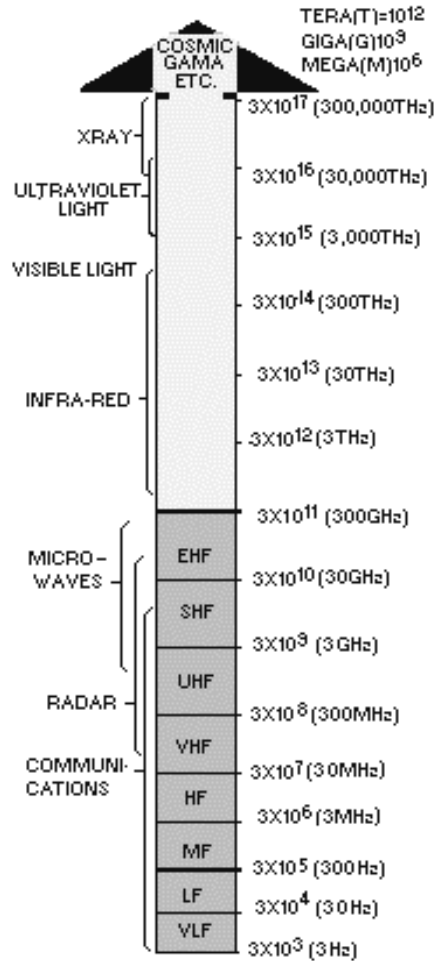

The **ELECTROMAGNETIC FIELD** consists of an **ELECTRIC FIELD** and a **MAGNETIC FIELD**. These fields are responsible for the transmission and reception of electromagnetic energy through free space.

ANSWERS TO QUESTIONS Q1. THROUGH Q48.

- A1. Propagation means spreading out.
- A2. A wave is a disturbance which moves through a medium.
- A3. A means of transferring energy from one place to another.
- A4. Sound waves, light waves, radio waves, heat waves, water waves.
- A5. Transverse waves.
- A6. Radio waves, light waves, and heat waves.

- A7. *A sound wave.*
- A8. *A source, medium, and detector (receiver).*
- A9. *A sequence of events, such as the positive and negative alternation of electrical current.*
- A10. *The space occupied by one cycle of a radio wave at any given instant.*
- A11. *The law of reflection states: The angle of incidence is equal to the angle of reflection.*
- A12. *When the incident wave is nearly parallel with the surface.*
- A13. *When the incident wave is perpendicular to the surface. Also a dull (or black) surface reflects very little regardless of the angle.*
- A14. *The density of the two mediums, and the velocity of the waves.*
- A15. *The Doppler effect.*
- A16. *Sonics.*
- A17. *No. The average human ear cannot hear all sounds in the infrasonic and ultrasonic regions.*
- A18. *An amplifier.*
- A19. *A source, medium, and detector (receiver).*
- A20. *Noise and tones.*
- A21. *Pitch, intensity, and quality.*
- A22. *20 Hz to 20 kHz.*
- A23. *The amount of energy transmitted from a source.*
- A24. *Quality.*
- A25. *Velocity increases as density decreases and temperature increases.*
- A26. *Acoustics.*
- A27. *Echo.*
- A28. *Reverberation.*
- A29. *Resonance.*
- A30. *Noise.*
- A31. *Mechanical, electrical, and chemical.*
- A32. *A photon.*
- A33. *Angstrom unit.*
- A34. *Red, green and blue.*

CHAPTER 2

RADIO WAVE PROPAGATION

LEARNING OBJECTIVES

Upon completion of this unit, you should be able to:

1. State what the electromagnetic field is and what components make up the electromagnetic field.
2. State the difference between the induction field and the radiation field.
3. State what radio waves are.
4. List the components of a radio wave and define the terms cycle, frequency, harmonics, period, wavelength, and velocity as applied to radio wave propagation.
5. Compute the wavelength of radio waves.
6. State how radio waves are polarized, vertically and horizontally.
7. State what reflection, refraction, and diffraction are as applied to radio waves.
8. State what influence the Earth's atmosphere has on radio waves and list the different layers of the Earth's atmosphere.
9. Identify a ground wave, a sky wave, and state the effects of the ionosphere on the sky wave.
10. Identify the structure of the ionosphere.
11. Define density of layer, frequency, angle of incidence, skip distance, and skip zone.
12. Describe propagation paths.
13. Describe fading, multipath fading, and selective fading. Describe propagation paths.
14. State how transmission losses affect radio wave propagation.
15. State how electromagnetic interference, man-made/natural interference, and ionospheric disturbances affect radio wave propagation. State how transmission losses affect radio wave propagation.
16. Identify variations in the ionosphere.
17. Identify the maximum, optimum, and lowest usable frequencies of radio waves.
18. State what temperature inversion is, how frequency predictions are made, and how weather affects frequency.
19. State what tropospheric scatter is and how it affects radio wave propagation.

ELECTROMAGNETIC FIELDS

The way energy is propagated into free space is a source of great dispute among people concerned with it. Although many theories have been proposed, the following theory adequately explains the phenomena and has been widely accepted. There are two basic fields associated with every antenna; an INDUCTION FIELD and a RADIATION FIELD. The field associated with the energy stored in the antenna is the induction field. This field is said to provide no part in the transmission of electromagnetic energy through free space. However, without the presence of the induction field, there would be no energy radiated.

INDUCTION FIELD

Figure 2-1, a low-frequency generator connected to an antenna, will help you understand how the induction field is produced. Let's follow the generator through one cycle of operation.

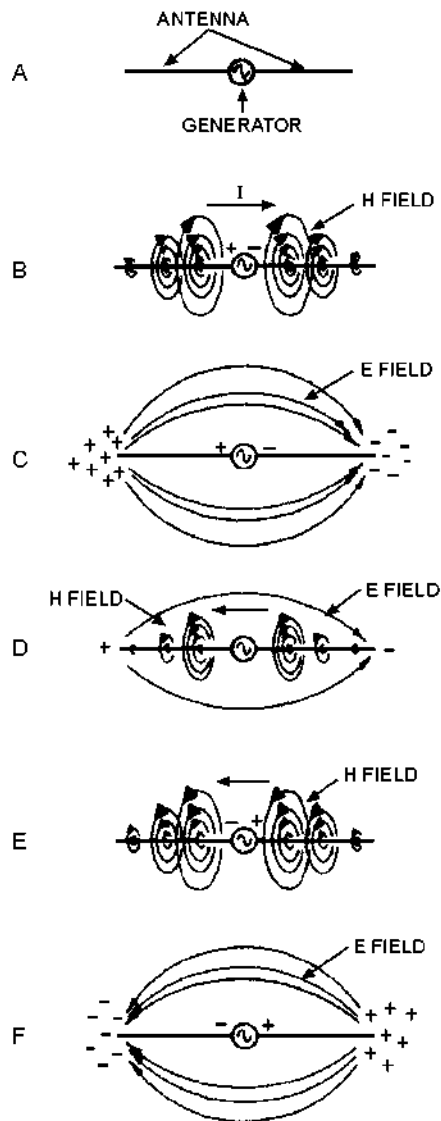

Figure 2-1.—Induction field about an antenna.

Initially, you can consider that the generator output is zero and that no fields exist about the antenna, as shown in view A. Now assume that the generator produces a slight potential and has the instantaneous polarity shown in view B. Because of this slight potential, the antenna capacitance acts as a short, allowing a large flow of current (I) through the antenna in the direction shown. This current flow, in turn, produces a large magnetic field about the antenna. Since the flow of current at each end of the antenna is minimum, the corresponding magnetic fields at each end of the antenna are also minimum. As time passes, charges, which oppose antenna current and produce an electrostatic field (E field), collect at each end of the antenna. Eventually, the antenna capacitance becomes fully charged and stops current flow through the antenna. Under this condition, the electrostatic field is maximum, and the magnetic field (H field) is fully collapsed, as shown in view C.

As the generator potential decreases back to zero, the potential of the antenna begins to discharge. During the discharging process, the electrostatic field collapses and the direction of current flow reverses, as shown in view D. When the current again begins to flow, an associated magnetic field is generated. Eventually, the electrostatic field completely collapses, the generator potential reverses, and current is maximum, as shown in view E. As charges collect at each end of the antenna, an electrostatic field is produced and current flow decreases. This causes the magnetic field to begin collapsing. The collapsing magnetic field produces more current flow, a greater accumulation of charge, and a greater electrostatic field. The antenna gradually reaches the condition shown in view F, where current is zero and the collected charges are maximum.

As the generator potential again decreases toward zero, the antenna begins to discharge and the electrostatic field begins to collapse. When the generator potential reaches zero, discharge current is maximum and the associated magnetic field is maximum. A brief time later, generator potential reverses, and the condition shown in view B recurs.

NOTE: The electric field (E field) and the electrostatic field (E field) are the same. They will be used interchangeably throughout this text.

The graph shown in figure 2-2 shows the relationship between the magnetic (H) field and the electric (E) field plotted against time. Note that the two fields are 90 degrees out of phase with each other. If you compare the graph in figure 2-2 with figure 2-1, you will notice that the two fields around the antenna are displaced 90 degrees from each other in space. (The H field exists in a plane perpendicular to the antenna. The E field exists in a plane parallel with the antenna, as shown in figure 2-1.)

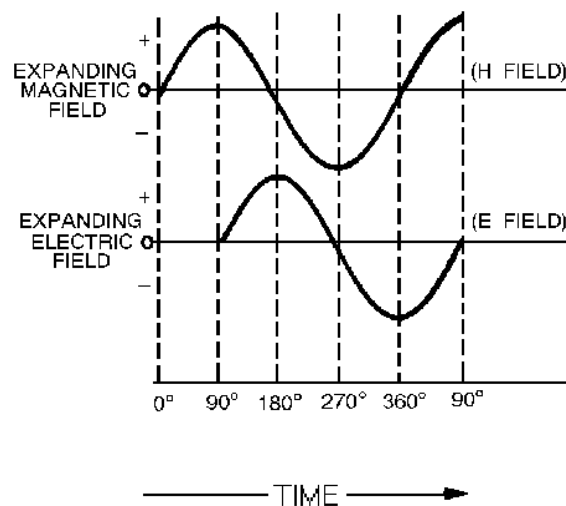

Figure 2-2.—Phase relationship of induction field components.

All the energy supplied to the induction field is returned to the antenna by the collapsing E and H fields. No energy from the induction field is radiated from the antenna. Therefore, the induction field is considered a local field and plays no part in the transmission of electromagnetic energy. The induction field represents only the stored energy in the antenna and is responsible only for the resonant effects that the antenna reflects to the generator.

RADIATION FIELDS

The E and H fields that are set up in the transfer of energy through space are known collectively as the radiation field. This radiation field is responsible for electromagnetic radiation from the antenna. The radiation field decreases as the distance from the antenna is increased. Because the decrease is linear, the radiation field reaches great distances from the antenna.

Let's look at a half-wave antenna to illustrate how this radiation actually takes place. Simply stated, a half-wave antenna is one that has an electrical length equal to half the wavelength of the signal being transmitted. Assume, for example, that a transmitter is operating at 30 megahertz. If a half-wave antenna is used with the transmitter, the antenna's electrical length would have to be at least 16 feet long. (The formula used to compute the electrical length of an antenna will be explained in chapter 4.) When power is delivered to the half-wave antenna, both an induction field and a radiation field are set up by the fluctuating energy. At the antenna, the intensities of these fields are proportional to the amount of power delivered to the antenna from a source such as a transmitter. At a short distance from the antenna and beyond, only the radiation field exists. This radiation field is made up of an electric component and a magnetic component at right angles to each other in space and varying together in intensity.

With a high-frequency generator (a transmitter) connected to the antenna, the induction field is produced as described in the previous section. However, the generator potential reverses before the electrostatic field has had time to collapse completely. The reversed generator potential neutralizes the remaining antenna charges, leaving a resultant E field in space.

Figure 2-3 is a simple picture of an E field detaching itself from an antenna. (The H field will not be considered, although it is present.) In view A the voltage is maximum and the electric field has maximum intensity. The lines of force begin at the end of the antenna that is positively charged and extend to the end of the antenna that is negatively charged. Note that the outer E lines are stretched away from the inner lines. This is because of the repelling force that takes place between lines of force in the same direction. As the voltage drops (view B), the separated charges come together, and the ends of the lines move toward the center of the antenna. But, since lines of force in the same direction repel each other, the centers of the lines are still being held out.

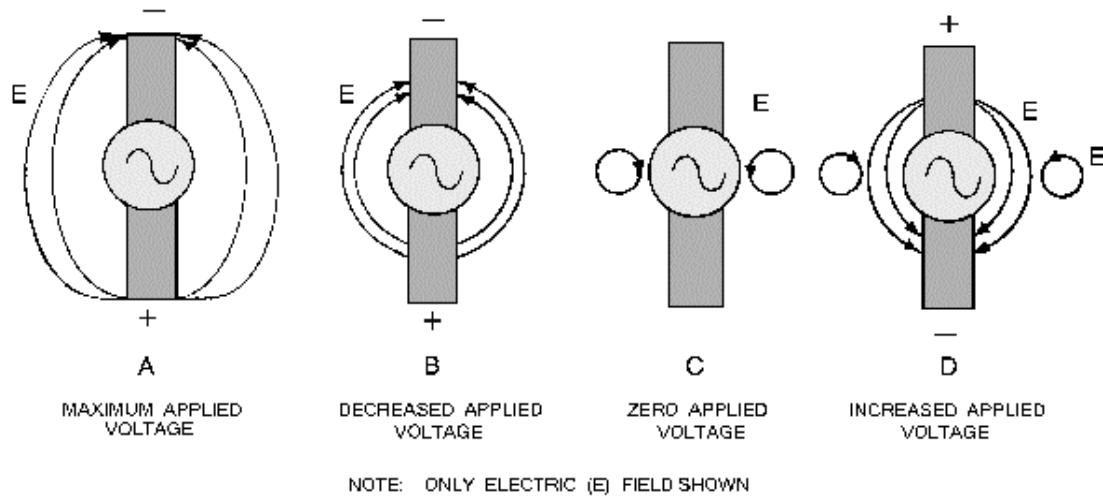

Figure 2-3.—Radiation from an antenna.

As the voltage approaches zero (view B), some of the lines collapse back into the antenna. At the same time, the ends of other lines begin to come together to form a complete loop. Notice the direction of these lines of force next to the antenna in view C. At this point the voltage on the antenna is zero. As the charge starts to build up in the opposite direction (view D), electric lines of force again begin at the positive end of the antenna and stretch to the negative end of the antenna. These lines of force, being in the same direction as the sides of the closed loops next to the antenna, repel the closed loops and force them out into space at the speed of light. As these loops travel through space, they generate a magnetic field in phase with them.

Since each successive E field is generated with a polarity that is opposite the preceding E field (that is, the lines of force are opposite), an oscillating electric field is produced along the path of travel. When an electric field oscillates, a magnetic field having an intensity that varies directly with that of the E field is produced. The variations in magnetic field intensity, in turn, produce another E field. Thus, the two varying fields sustain each other, resulting in electromagnetic wave propagation.

During this radiation process, the E and H fields are in phase in time but physically displaced 90 degrees in space. Thus, the varying magnetic field produces a varying electric field; and the varying electric field, in turn, sustains the varying magnetic field. Each field supports the other, and neither can be propagated by itself. Figure 2-4 shows a comparison between the induction field and the radiation field.

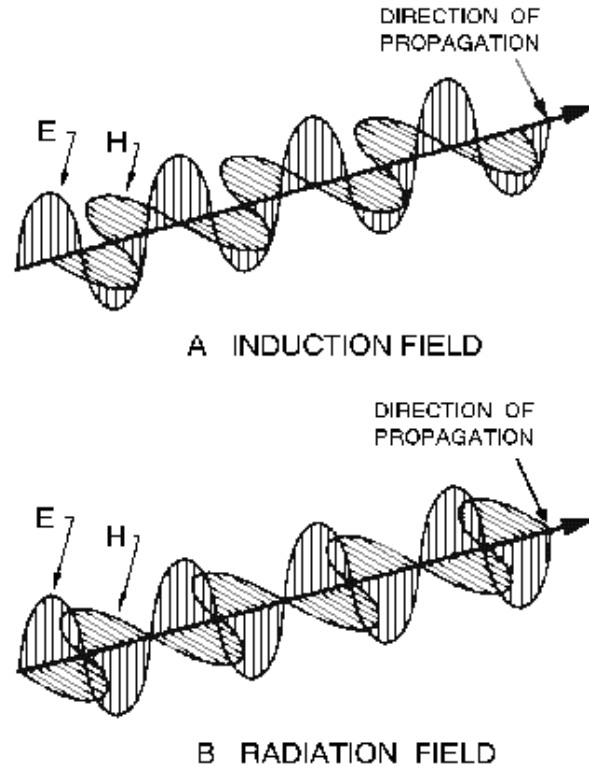

Figure 2-4.—E and H components of induction and radiation fields.

- Q1. Which two composite fields (composed of E and H fields) are associated with every antenna?
- Q2. What composite field (composed of E and H fields) is found stored in the antenna?
- Q3. What composite field (composed of E and H fields) is propagated into free space?

RADIO WAVES

An energy wave generated by a transmitter is called a RADIO WAVE. The radio wave radiated into space by the transmitting antenna is a very complex form of energy containing both electric and magnetic fields. Because of this combination of fields, radio waves are also referred to as ELECTROMAGNETIC RADIATION.

This discussion will explain the Earth's atmosphere and its effect on radio waves. All the principles of wave motion that were discussed in chapter 1 also apply to radio waves.

NOTE: The term *radio wave* is not limited to communications equipment alone. The term applies to all equipment that generate signals in the form of electromagnetic energy.

COMPONENTS OF RADIO WAVES

The basic shape of the wave generated by a transmitter is that of a sine wave. The wave radiated out into space, however, may or may not retain the characteristics of the sine wave.

A sine wave can be one cycle or many cycles. Recall from chapter 1 that the number of cycles of a sine wave that are completed in 1 second is known as the *frequency* of the sine wave. For example, 60 cycles of ordinary house current occur each second, so house current is said to have a frequency of 60 cycles per second or 60 hertz.

The frequencies falling between 3000 hertz (3 kHz) and 300,000,000,000 hertz (300 GHz) are called RADIO FREQUENCIES (abbreviated rf) since they are commonly used in radio communications. This part of the radio frequency spectrum is divided into bands, each band being 10 times higher in frequency than the one immediately below it. This arrangement serves as a convenient way to remember the range of each band. The rf bands are shown in table 2-1. The usable radio-frequency range is roughly 10 kilohertz to 100 gigahertz.

Table 2-1.—Radio Frequency Bands

| DESCRIPTION | ABBREVIATION | FREQUENCY |
|--------------------|---------------------|------------------|
| Very low | VLF | 3 to 30 KHz |
| Low | LF | 30 to 300 KHz |
| Medium | MF | 300 to 3000 KHz |
| High | HF | 3 to 30 MHz |
| Very high | VHF | 30 to 300 MHz |
| Ultrahigh | UHF | 300 to 3000 MHz |
| Super high | SHF | 3 to 30 GHz |
| Extremely high | EHF | 30 to 300 GHz |

Any frequency that is a whole number multiple of a smaller basic frequency is known as a HARMONIC of that basic frequency. The basic frequency itself is called the first harmonic or, more commonly, the FUNDAMENTAL FREQUENCY. A frequency that is twice as great as the fundamental frequency is called the second harmonic; a frequency three times as great is the third harmonic; and so on. For example:

| | |
|--|----------|
| First harmonic (Fundamental frequency) | 3000 kHz |
| Second harmonic | 6000 kHz |
| Third harmonic | 9000 kHz |

The PERIOD of a radio wave is simply the amount of time required for the completion of one full cycle. If a sine wave has a frequency of 2 hertz, each cycle has a duration, or period, of one-half second. If the frequency is 10 hertz, the period of each cycle is one-tenth of a second. Since the frequency of a radio wave is the number of cycles that are completed in one second, you should be able to see that as the frequency of a radio wave increases, its period decreases.

A wavelength is the space occupied by one full cycle of a radio wave at any given instant. Wavelengths are expressed in meters (1 meter is equal to 3.28 feet). You need to have a good understanding of frequency and wavelength to be able to select the proper antenna(s) for use in successful

communications. The relationship between frequency, wavelength, and antennas will be discussed in chapter 4 of this module.

The velocity (or speed) of a radio wave radiated into free space by a transmitting antenna is equal to the speed of light—186,000 miles per second or 300,000,000 meters per second. Because of various factors, such as barometric pressure, humidity, molecular content, etc., radio waves travel inside the Earth's atmosphere at a speed slightly less than the speed of light. Normally, in discussions of the velocity of radio waves, the velocity referred to is the speed at which radio waves travel in free space.

The frequency of a radio wave has nothing to do with its velocity. A 5-megahertz wave travels through space at the same velocity as a 10-megahertz wave. However, the velocity of radio waves is an important factor in making wavelength-to-frequency conversions, the subject of our next discussion.

Q4. What is the term used to describe the basic frequency of a radio wave?

Q5. What is the term used to describe a whole number multiple of the basic frequency of a radio wave?

WAVELENGTH-TO-FREQUENCY CONVERSIONS

Radio waves are often referred to by their wavelength in meters rather than by frequency. For example, most people have heard commercial radio stations make announcements similar to the following: "Station WXYZ operating on 240 meters..." To tune receiving equipment that is calibrated by frequency to such a station, you must first convert the designated wavelength to its equivalent frequency.

As discussed earlier, a radio wave travels 300,000,000 meters a second (speed of light); therefore, a radio wave of 1 hertz would have traveled a distance (or wavelength) of 300,000,000 meters. Obviously then, if the frequency of the wave is increased to 2 hertz, the wavelength will be cut in half to 150,000,000 meters. This illustrates the principle that the HIGHER THE FREQUENCY, the SHORTER THE WAVELENGTH.

Wavelength-to-frequency conversions of radio waves are really quite simple because wavelength and frequency are reciprocals: Either one divided into the velocity of a radio wave yields the other. Remember, the formula for wavelength is:

$$\lambda = \frac{v}{f} \quad \text{or} \quad f = \frac{v}{\lambda}$$

Where:

λ = wavelength in meters

v = velocity of radio wave
(speed of light)

f = frequency of radio wave
(in Hz, kHz or Mhz)

The wavelength in meters divided into 300,000,000 yields the frequency of a radio wave in hertz. Likewise, the wavelength divided into 300,000 yields the frequency of a radio wave in kilohertz, and the wavelength divided into 300 yields the frequency in megahertz.

Now, let us apply the formula to determine the frequency to which the receiving equipment must be tuned to receive station WXYZ operating on 240 meters. Radio wave frequencies are normally expressed in kilohertz or megahertz.

To find the frequency in hertz, use the formula:

$$f = \frac{v}{\lambda}$$

Given:

$$v = 300,000,000 \text{ meters per second}$$

$$\lambda = 240 \text{ meters}$$

Solution:

$$f = \frac{300,000,000 \text{ meters per second}}{240 \text{ meters}}$$

$$f = 1,250,000 \text{ Hz}$$

To find the frequency in kilohertz, use the formula:

$$f_{[\text{kHz}]} = \frac{300,000}{\lambda}$$

Given:

$$\lambda = 240 \text{ meters}$$

Solution:

$$f_{[\text{kHz}]} = \frac{300,000}{240 \text{ meters}}$$

$$f = 1250 \text{ kHz}$$

To find the frequency in megahertz, use the formula:

$$f_{[\text{MHz}]} = \frac{300}{\lambda}$$

Given:

$$\lambda = 240 \text{ meters}$$

Solution:

$$f_{[\text{MHz}]} = \frac{300}{240 \text{ meters}}$$

$$f = 1.25 \text{ MHz}$$

Q6. It is known that WWV operates on a frequency of 10 megahertz. What is the wavelength of WWV?

Q7. A station is known to operate at 60-meters. What is the frequency of the unknown station?

POLARIZATION

For maximum absorption of energy from the electromagnetic fields, the receiving antenna must be located in the plane of polarization. This places the conductor of the antenna at right angles to the magnetic lines of force moving through the antenna and parallel to the electric lines, causing maximum induction.

Normally, the plane of polarization of a radio wave is the plane in which the E field propagates with respect to the Earth. If the E field component of the radiated wave travels in a plane perpendicular to the Earth's surface (vertical), the radiation is said to be VERTICALLY POLARIZED, as shown in figure 2-5, view A. If the E field propagates in a plane parallel to the Earth's surface (horizontal), the radiation is said to be HORIZONTALLY POLARIZED, as shown in view B.

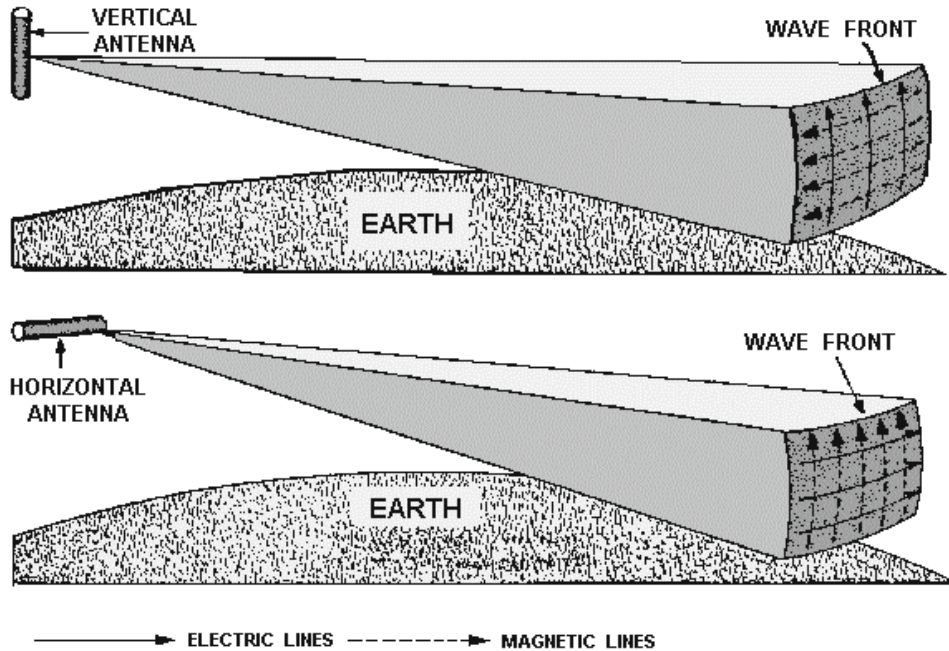

Figure 2-5.—Vertical and horizontal polarization.

The position of the antenna in space is important because it affects the polarization of the electromagnetic wave. When the transmitting antenna is close to the ground, vertically polarized waves cause a greater signal strength along the Earth's surface. On the other hand, antennas high above the ground should be horizontally polarized to get the greatest possible signal strength to the Earth's surface. Vertically and horizontally polarized antennas will be discussed in more detail in chapter 4.

The radiated energy from an antenna is in the form of an expanding sphere. Any small section of this sphere is perpendicular to the direction the energy travels and is called a WAVEFRONT. All energy on a wavefront is in phase. Usually all points on the wavefront are at equal distances from the antenna. The farther the wavefront is from the antenna, the less spherical the wave appears. At a considerable distance the wavefront can be considered as a plane surface at a right angle to the direction of propagation.

If you know the directions of the E and H components, you can use the "right-hand rule" (see figure 2-6) to determine the direction of wave propagation. This rule states that if the thumb, forefinger, and middle finger of the right hand are extended so they are mutually perpendicular, the middle finger will point in the direction of wave propagation if the thumb points in the direction of the E field and the forefinger points in the direction of the H field. Since both the E and H fields reverse directions simultaneously, propagation of a particular wavefront is always in the same direction (away from the antenna).

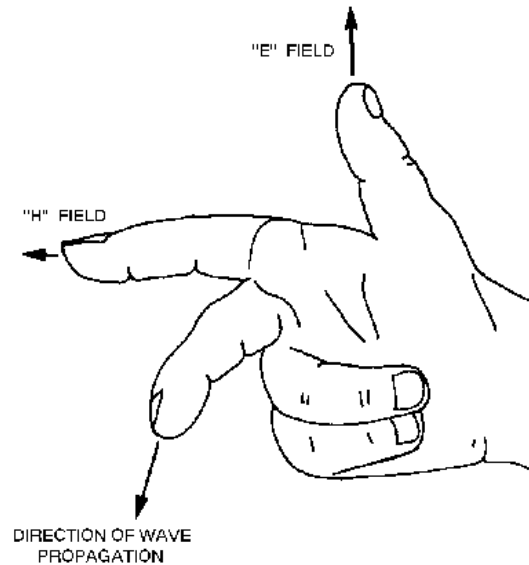

Figure 2-6.—Right-hand rule for propagation.

- Q8. If a transmitting antenna is placed close to the ground, how should the antenna be polarized to give the greatest signal strength?*
- Q9. In the right-hand rule for propagation, the thumb points in the direction of the E field and the forefinger points in the direction of the H field. In what direction does the middle finger point?*

ATMOSPHERIC PROPAGATION

Within the atmosphere, radio waves can be reflected, refracted, and diffracted like light and heat waves.

Reflection

Radio waves may be reflected from various substances or objects they meet during travel between the transmitting and receiving sites. The amount of reflection depends on the reflecting material. Smooth metal surfaces of good electrical conductivity are efficient reflectors of radio waves. The surface of the Earth itself is a fairly good reflector. The radio wave is not reflected from a single point on the reflector but rather from an area on its surface. The size of the area required for reflection to take place depends on the wavelength of the radio wave and the angle at which the wave strikes the reflecting substance.

When radio waves are reflected from flat surfaces, a phase shift in the alternations of the wave occurs. Figure 2-7 shows two radio waves being reflected from the Earth's surface. Notice that the positive and negative alternations of radio waves (A) and (B) are in phase with each other in their paths toward the Earth's surface. After reflection takes place, however, the waves are approximately 180 degrees out of phase from their initial relationship. The amount of phase shift that occurs is not constant.

It depends on the polarization of the wave and the angle at which the wave strikes the reflecting surface. Radio waves that keep their phase relationships after reflection normally produce a stronger signal at the receiving site. Those that are received out of phase produce a weak or fading signal. The shifting in the phase relationships of reflected radio waves is one of the major reasons for fading. Fading will be discussed in more detail later in this chapter.

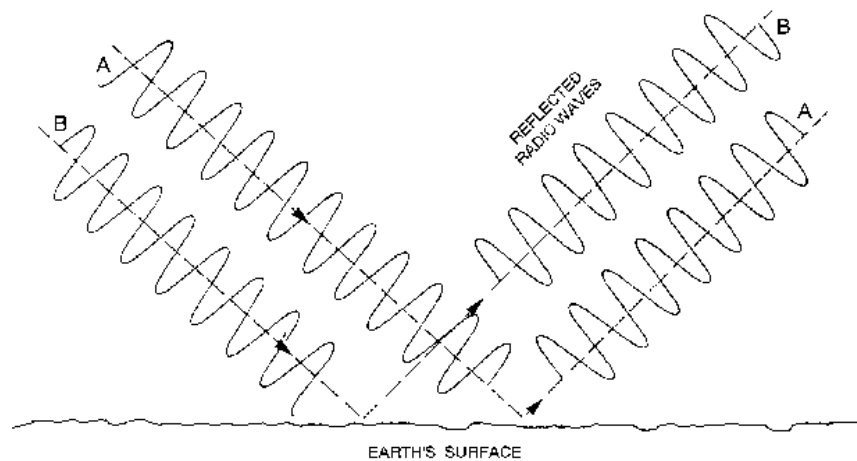

Figure 2-7.—Phase shift of reflected radio waves.

Refraction

Another phenomenon common to most radio waves is the bending of the waves as they move from one medium into another in which the velocity of propagation is different. This bending of the waves is called refraction. For example, suppose you are driving down a smoothly paved road at a constant speed and suddenly one wheel goes off onto the soft shoulder. The car tends to veer off to one side. The change of medium, from hard surface to soft shoulder, causes a change in speed or velocity. The tendency is for the car to change direction. This same principle applies to radio waves as changes occur in the medium through which they are passing. As an example, the radio wave shown in figure 2-8 is traveling through the Earth's atmosphere at a constant speed. As the wave enters the dense layer of electrically charged ions, the part of the wave that enters the new medium first travels faster than the parts of the wave that have not yet entered the new medium. This abrupt increase in velocity of the upper part of the wave causes the wave to bend back toward the Earth. This bending, or change of direction, is always toward the medium that has the lower velocity of propagation.

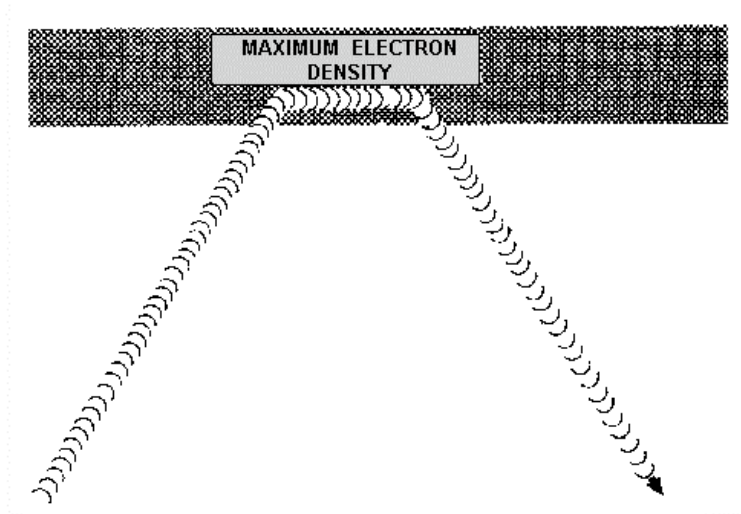

Figure 2-8.—Radio wave refraction.

Radio waves passing through the atmosphere are affected by certain factors, such as temperature, pressure, humidity, and density. These factors can cause the radio waves to be refracted. This effect will be discussed in greater detail later in this chapter.

Diffraction

A radio wave that meets an obstacle has a natural tendency to bend around the obstacle as illustrated in figure 2-9. The bending, called diffraction, results in a change of direction of part of the wave energy from the normal line-of-sight path. This change makes it possible to receive energy around the edges of an obstacle as shown in view A or at some distances below the highest point of an obstruction, as shown in view B. Although diffracted rf energy usually is weak, it can still be detected by a suitable receiver. The principal effect of diffraction extends the radio range beyond the visible horizon. In certain cases, by using high power and very low frequencies, radio waves can be made to encircle the Earth by diffraction.

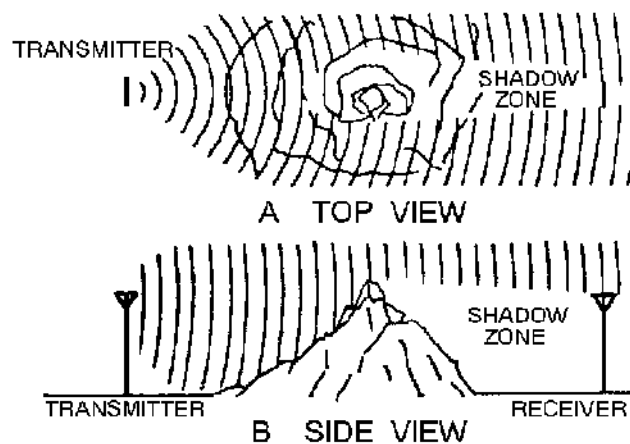

Figure 2-9.—Diffraction around an object.

Q10. What is one of the major reasons for the fading of radio waves which have been reflected from a surface?

THE EFFECT OF THE EARTH'S ATMOSPHERE ON RADIO WAVES

This discussion of electromagnetic wave propagation is concerned mainly with the properties and effects of the medium located between the transmitting antenna and the receiving antenna. While radio waves traveling in free space have little outside influence affecting them, radio waves traveling within the Earth's atmosphere are affected by varying conditions. The influence exerted on radio waves by the Earth's atmosphere adds many new factors to complicate what at first seems to be a relatively simple problem. These complications are because of a lack of uniformity within the Earth's atmosphere. Atmospheric conditions vary with changes in height, geographical location, and even with changes in time (day, night, season, year). A knowledge of the composition of the Earth's atmosphere is extremely important for understanding wave propagation.

The Earth's atmosphere is divided into three separate regions, or layers. They are the TROPOSPHERE, the STRATOSPHERE, and the IONOSPHERE. The layers of the atmosphere are illustrated in figure 2-10.

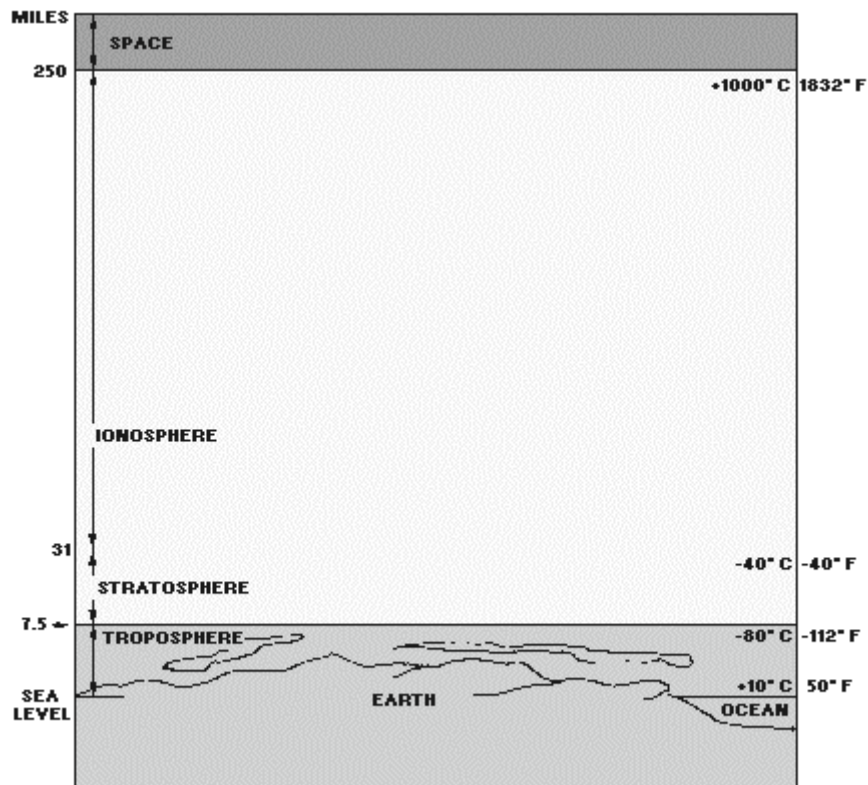

Figure 2-10.—Layers of the earth's atmosphere.

TROPOSPHERE

The troposphere is the portion of the Earth's atmosphere that extends from the surface of the Earth to a height of about 3.7 miles (6 km) at the North Pole or the South Pole and 11.2 miles (18 km) at the

equator. Virtually all weather phenomena take place in the troposphere. The temperature in this region decreases rapidly with altitude, clouds form, and there may be much turbulence because of variations in temperature, density, and pressure. These conditions have a great effect on the propagation of radio waves, which will be explained later in this chapter.

STRATOSPHERE

The stratosphere is located between the troposphere and the ionosphere. The temperature throughout this region is considered to be almost constant and there is little water vapor present. The stratosphere has relatively little effect on radio waves because it is a relatively calm region with little or no temperature changes.

IONOSPHERE

The ionosphere extends upward from about 31.1 miles (50 km) to a height of about 250 miles (402 km). It contains four cloud-like layers of electrically charged ions, which enable radio waves to be propagated to great distances around the Earth. This is the most important region of the atmosphere for long distance point-to-point communications. This region will be discussed in detail a little later in this chapter.

Q11. What are the three layers of the atmosphere?

Q12. Which layer of the atmosphere has relatively little effect on radio waves?

RADIO WAVE TRANSMISSION

There are two principal ways in which electromagnetic (radio) energy travels from a transmitting antenna to a receiving antenna. One way is by GROUND WAVES and the other is by SKY WAVES. Ground waves are radio waves that travel near the surface of the Earth (surface and space waves). Sky waves are radio waves that are reflected back to Earth from the ionosphere. (See figure 2-11.)

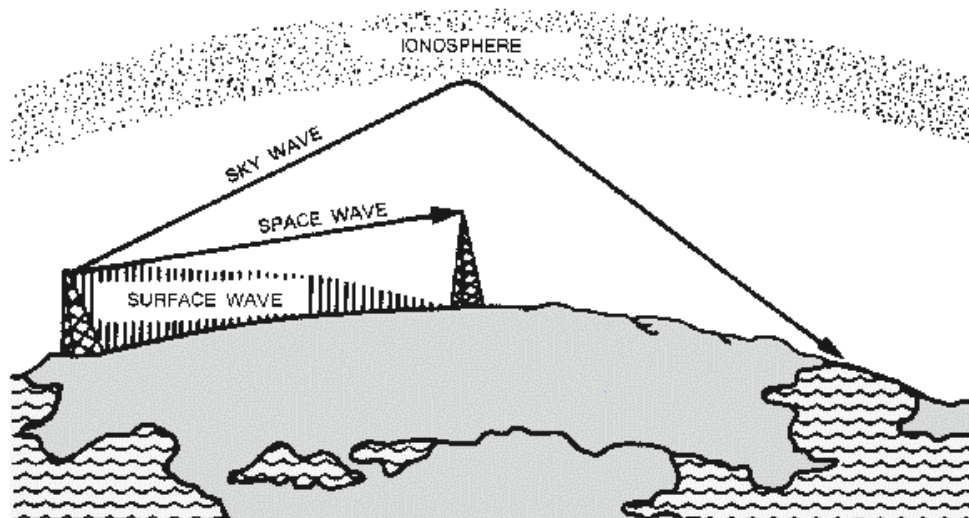

Figure 2-11.—Ground waves and sky waves.

Ground Waves

The ground wave is actually composed of two separate component waves. These are known as the SURFACE WAVE and the SPACE WAVE (fig. 2-11). The determining factor in whether a ground wave component is classified as a space wave or a surface wave is simple. A surface wave travels along the surface of the Earth. A space wave travels over the surface.

SURFACE WAVE.—The surface wave reaches the receiving site by traveling along the surface of the ground as shown in figure 2-12. A surface wave can follow the contours of the Earth because of the process of diffraction. When a surface wave meets an object and the dimensions of the object do not exceed its wavelength, the wave tends to curve or bend around the object. The smaller the object, the more pronounced the diffractive action will be.

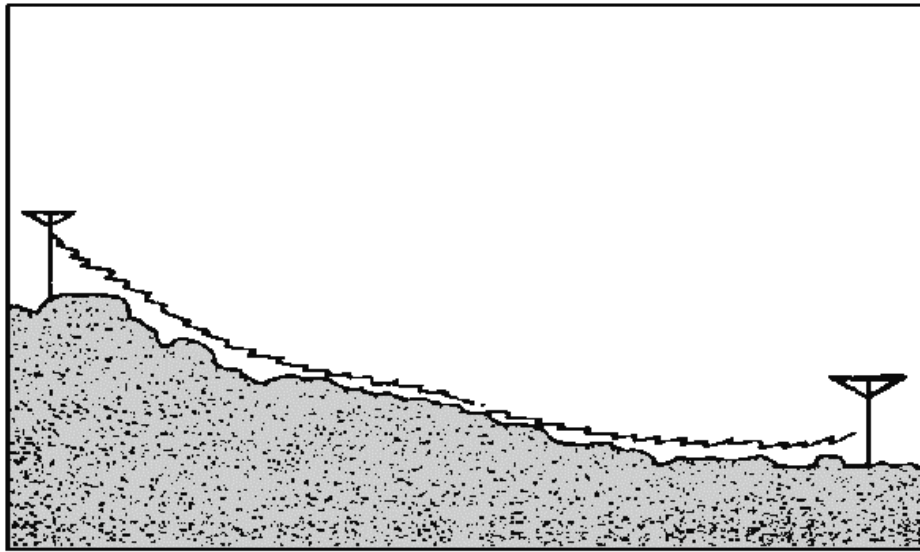

Figure 2-12.—Surface wave propagation.

As a surface wave passes over the ground, the wave induces a voltage in the Earth. The induced voltage takes energy away from the surface wave, thereby weakening, or attenuating, the wave as it moves away from the transmitting antenna. To reduce the attenuation, the amount of induced voltage must be reduced. This is done by using vertically polarized waves that minimize the extent to which the electric field of the wave is in contact with the Earth. When a surface wave is horizontally polarized, the electric field of the wave is parallel with the surface of the Earth and, therefore, is constantly in contact with it. The wave is then completely attenuated within a short distance from the transmitting site. On the other hand, when the surface wave is vertically polarized, the electric field is vertical to the Earth and merely dips into and out of the Earth's surface. For this reason, vertical polarization is vastly superior to horizontal polarization for surface wave propagation.

The attenuation that a surface wave undergoes because of induced voltage also depends on the electrical properties of the terrain over which the wave travels. The best type of surface is one that has good electrical conductivity. The better the conductivity, the less the attenuation. Table 2-2 gives the relative conductivity of various surfaces of the Earth.

Table 2-2.—Surface Conductivity

| SURFACE | RELATIVE CONDUCTIVITY |
|-----------------------------|-----------------------|
| Sea water | Good |
| Flat, loamy soil | Fair |
| Large bodies of fresh water | Fair |
| Rocky terrain | Poor |
| Desert | Poor |
| Jungle | Unusable |

Another major factor in the attenuation of surface waves is frequency. Recall from earlier discussions on wavelength that the higher the frequency of a radio wave, the shorter its wavelength will be. These high frequencies, with their shorter wavelengths, are not normally diffracted but are absorbed by the Earth at points relatively close to the transmitting site. You can assume, therefore, that as the frequency of a surface wave is increased, the more rapidly the surface wave will be absorbed, or attenuated, by the Earth. Because of this loss by attenuation, the surface wave is impractical for long-distance transmissions at frequencies above 2 megahertz. On the other hand, when the frequency of a surface wave is low enough to have a very long wavelength, the Earth appears to be very small, and diffraction is sufficient for propagation well beyond the horizon. In fact, by lowering the transmitting frequency into the very low frequency (vlf) range and using very high-powered transmitters, the surface wave can be propagated great distances. The Navy's extremely high-powered vlf transmitters are actually capable of transmitting surface wave signals around the Earth and can provide coverage to naval units operating anywhere at sea.

SPACE WAVE.—The space wave follows two distinct paths from the transmitting antenna to the receiving antenna—one through the air directly to the receiving antenna, the other reflected from the ground to the receiving antenna. This is illustrated in figure 2-13. The primary path of the space wave is directly from the transmitting antenna to the receiving antenna. So, the receiving antenna must be located within the radio horizon of the transmitting antenna. Because space waves are refracted slightly, even when propagated through the troposphere, the radio horizon is actually about one-third farther than the line-of-sight or natural horizon.

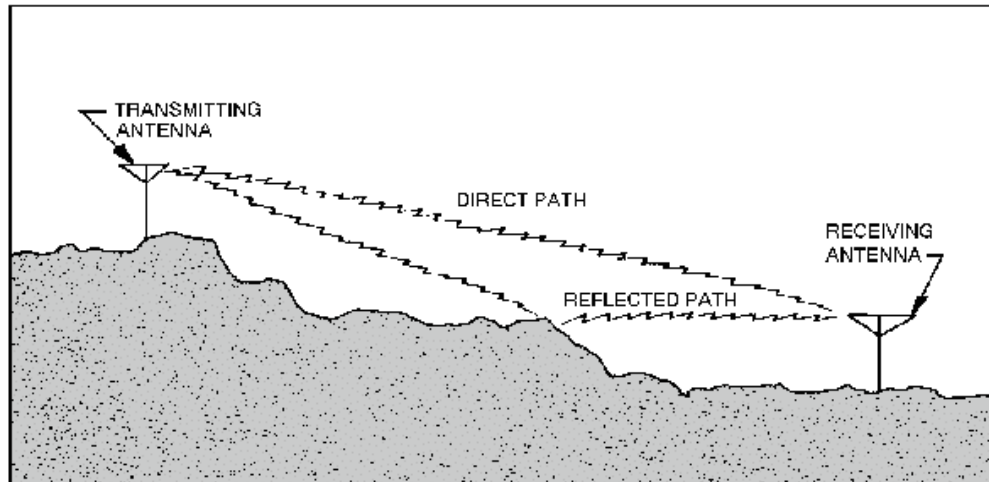

Figure 2-13.—Space wave propagation.

Although space waves suffer little ground attenuation, they nevertheless are susceptible to fading. This is because space waves actually follow two paths of different lengths (direct path and ground reflected path) to the receiving site and, therefore, may arrive in or out of phase. If these two component waves are received in phase, the result is a reinforced or stronger signal. Likewise, if they are received out of phase, they tend to cancel one another, which results in a weak or fading signal.

- Q13. What is the determining factor in classifying whether a radio wave is a ground wave or a space wave?*
- Q14. What is the best type of surface or terrain to use for radio wave transmission?*
- Q15. What is the primary difference between the radio horizon and the natural horizon?*
- Q16. What three factors must be considered in the transmission of a surface wave to reduce attenuation?*

Sky Wave

The sky wave, often called the ionospheric wave, is radiated in an upward direction and returned to Earth at some distant location because of refraction from the ionosphere. This form of propagation is relatively unaffected by the Earth's surface and can propagate signals over great distances. Usually the high frequency (hf) band is used for sky wave propagation. The following in-depth study of the ionosphere and its effect on sky waves will help you to better understand the nature of sky wave propagation.

STRUCTURE OF THE IONOSPHERE

As we stated earlier, the ionosphere is the region of the atmosphere that extends from about 30 miles above the surface of the Earth to about 250 miles. It is appropriately named the ionosphere because it consists of several layers of electrically charged gas atoms called ions. The ions are formed by a process called ionization.

Ionization

Ionization occurs when high energy ultraviolet light waves from the sun enter the ionospheric region of the atmosphere, strike a gas atom, and literally knock an electron free from its parent atom. A normal atom is electrically neutral since it contains both a positive proton in its nucleus and a negative orbiting electron. When the negative electron is knocked free from the atom, the atom becomes positively charged (called a positive ion) and remains in space along with the free electron, which is negatively charged. This process of upsetting electrical neutrality is known as IONIZATION.

The free negative electrons subsequently absorb part of the ultraviolet energy, which initially freed them from their atoms. As the ultraviolet light wave continues to produce positive ions and negative electrons, its intensity decreases because of the absorption of energy by the free electrons, and an ionized layer is formed. The rate at which ionization occurs depends on the density of atoms in the atmosphere and the intensity of the ultraviolet light wave, which varies with the activity of the sun.

Since the atmosphere is bombarded by ultraviolet light waves of different frequencies, several ionized layers are formed at different altitudes. Lower frequency ultraviolet waves penetrate the atmosphere the least; therefore, they produce ionized layers at the higher altitudes. Conversely, ultraviolet waves of higher frequencies penetrate deeper and produce layers at the lower altitudes.

An important factor in determining the density of ionized layers is the elevation angle of the sun, which changes frequently. For this reason, the height and thickness of the ionized layers vary, depending on the time of day and even the season of the year.

Recombination

Recall that the process of ionization involves ultraviolet light waves knocking electrons free from their atoms. A reverse process called RECOMBINATION occurs when the free electrons and positive ions collide with each other. Since these collisions are inevitable, the positive ions return to their original neutral atom state.

The recombination process also depends on the time of day. Between the hours of early morning and late afternoon, the rate of ionization exceeds the rate of recombination. During this period, the ionized layers reach their greatest density and exert maximum influence on radio waves. During the late afternoon and early evening hours, however, the rate of recombination exceeds the rate of ionization, and the density of the ionized layers begins to decrease. Throughout the night, density continues to decrease, reaching a low point just before sunrise.

Four Distinct Layers

The ionosphere is composed of three layers designated D, E, and F, from lowest level to highest level as shown in figure 2-14. The F layer is further divided into two layers designated F1 (the lower layer) and F2 (the higher layer). The presence or absence of these layers in the ionosphere and their height above the Earth varies with the position of the sun. At high noon, radiation in the ionosphere directly above a given point is greatest. At night it is minimum. When the radiation is removed, many of the particles that were ionized recombine. The time interval between these conditions finds the position and number of the ionized layers within the ionosphere changing. Since the position of the sun varies daily, monthly, and yearly, with respect to a specified point on Earth, the exact position and number of layers present are extremely difficult to determine. However, the following general statements can be made:

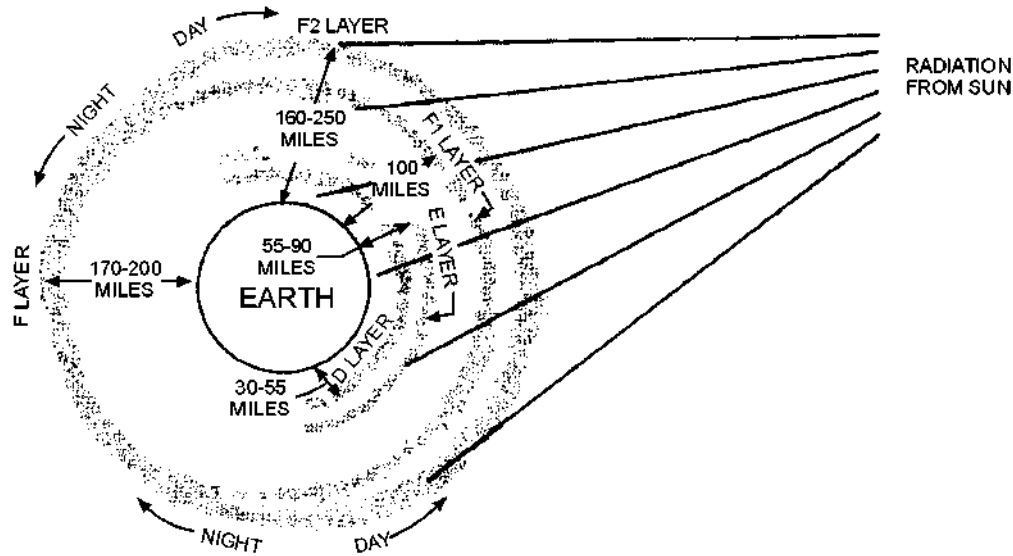

Figure 2-14.—Layers of the ionosphere.

- a. The D layer ranges from about 30 to 55 miles. Ionization in the D layer is low because it is the lowest region of the ionosphere. This layer has the ability to refract signals of low frequencies. High frequencies pass right through it and are attenuated. After sunset, the D layer disappears because of the rapid recombination of ions.
- b. The E layer limits are from about 55 to 90 miles. This layer is also known as the Kennelly-Heaviside layer, because these two men were the first to propose its existence. The rate of ionic recombination in this layer is rather rapid after sunset and the layer is almost gone by midnight. This layer has the ability to refract signals as high as 20 megahertz. For this reason, it is valuable for communications in ranges up to about 1500 miles.
- c. The F layer exists from about 90 to 240 miles. During the daylight hours, the F layer separates into two layers, the F1 and F2 layers. The ionization level in these layers is quite high and varies widely during the day. At noon, this portion of the atmosphere is closest to the sun and the degree of ionization is maximum. Since the atmosphere is rarefied at these heights, recombination occurs slowly after sunset. Therefore, a fairly constant ionized layer is always present. The F layers are responsible for high-frequency, long distance transmission.

Q17. *What causes ionization to occur in the ionosphere?*

Q18. *How are the four distinct layers of the ionosphere designated?*

Q19. *What is the height of the individual layers of the ionosphere?*

REFRACTION IN THE IONOSPHERE

When a radio wave is transmitted into an ionized layer, refraction, or bending of the wave, occurs. As we discussed earlier, refraction is caused by an abrupt change in the velocity of the upper part of a radio wave as it strikes or enters a new medium. The amount of refraction that occurs depends on three main factors: (1) the density of ionization of the layer, (2) the frequency of the radio wave, and (3) the angle at which the wave enters the layer.

Density of Layer

Figure 2-15 illustrates the relationship between radio waves and ionization density. Each ionized layer has a central region of relatively dense ionization, which tapers off in intensity both above and below the maximum region. As a radio wave enters a region of **INCREASING** ionization, the increase in velocity of the upper part of the wave causes it to be bent back **TOWARD** the Earth. While the wave is in the highly dense center portion of the layer, however, refraction occurs more slowly because the density of ionization is almost uniform. As the wave enters into the upper part of the layer of **DECREASING** ionization, the velocity of the upper part of the wave decreases, and the wave is bent **AWAY** from the Earth.

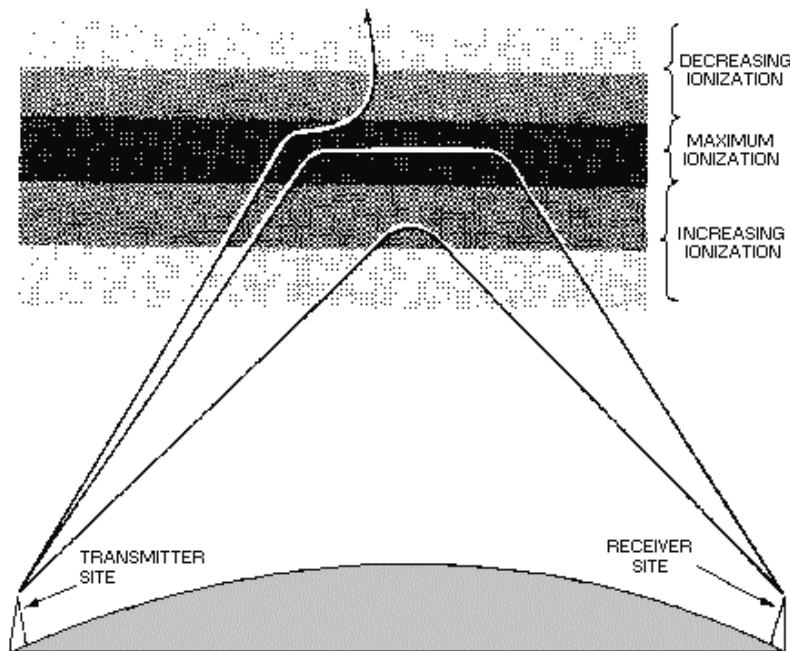

Figure 2-15.—Effects of ionospheric density on radio waves.

If a wave strikes a thin, very highly ionized layer, the wave may be bent back so rapidly that it will appear to have been reflected instead of refracted back to Earth. To reflect a radio wave, the highly ionized layer must be approximately no thicker than one wavelength of the radio wave. Since the ionized layers are often several miles thick, ionospheric reflection is more likely to occur at long wavelengths (low frequencies).

Frequency

For any given time, each ionospheric layer has a maximum frequency at which radio waves can be transmitted vertically and refracted back to Earth. This frequency is known as the **CRITICAL FREQUENCY**. It is a term that you will hear frequently in any discussion of radio wave propagation. Radio waves transmitted at frequencies higher than the critical frequency of a given layer will pass through the layer and be lost in space; but if these same waves enter an upper layer with a higher critical frequency, they will be refracted back to Earth. Radio waves of frequencies lower than the critical frequency will also be refracted back to Earth unless they are absorbed or have been refracted from a

lower layer. The lower the frequency of a radio wave, the more rapidly the wave is refracted by a given degree of ionization. Figure 2-16 shows three separate waves of different frequencies entering an ionospheric layer at the same angle. Notice that the 5-megahertz wave is refracted quite sharply. The 20-megahertz wave is refracted less sharply and returned to Earth at a greater distance. The 100-megahertz wave is obviously greater than the critical frequency for that ionized layer and, therefore, is not refracted but is passed into space.

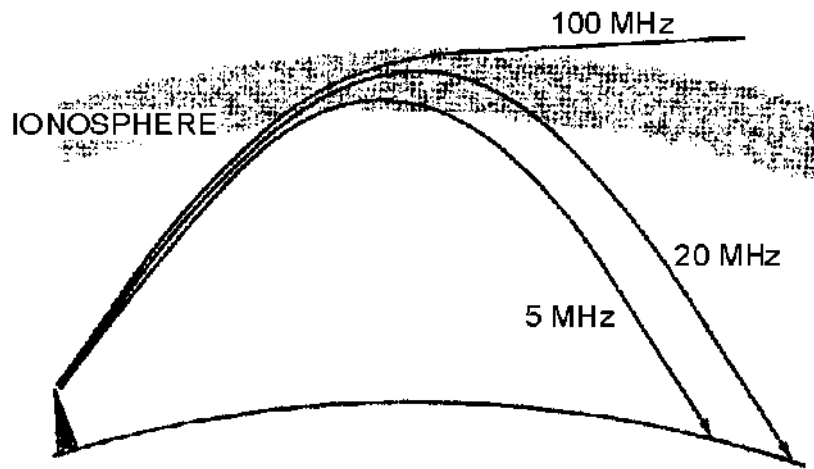

Figure 2-16.—Frequency versus refraction and distance.

Angle of Incidence

The rate at which a wave of a given frequency is refracted by an ionized layer depends on the angle at which the wave enters the layer. Figure 2-17 shows three radio waves of the same frequency entering a layer at different angles. The angle at which wave A strikes the layer is too nearly vertical for the wave to be refracted to Earth. As the wave enters the layer, it is bent slightly but passes through the layer and is lost. When the wave is reduced to an angle that is less than vertical (wave B), it strikes the layer and is refracted back to Earth. The angle made by wave B is called the **CRITICAL ANGLE** for that particular frequency. Any wave that leaves the antenna at an angle greater than the critical angle will penetrate the ionospheric layer for that frequency and then be lost in space. Wave C strikes the ionosphere at the smallest angle at which the wave can be refracted and still return to Earth. At any smaller angle, the wave will be refracted but will not return to Earth.

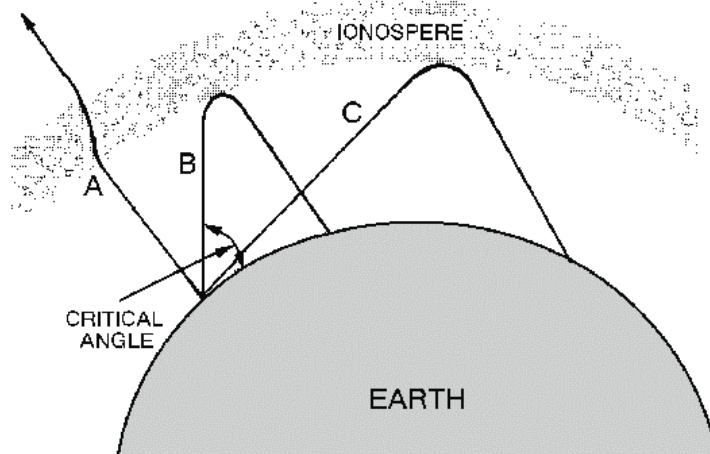

Figure 2-17.—Different incident angles of radio waves.

As the frequency of the radio wave is increased, the critical angle must be reduced for refraction to occur. This is illustrated in figure 2-18. The 2-megahertz wave strikes the layer at the critical angle for that frequency and is refracted back to Earth. Although the 5-megahertz wave (broken line) strikes the ionosphere at a lesser angle, it nevertheless penetrates the layer and is lost. As the angle is lowered from the vertical, however, a critical angle for the 5-megahertz wave is reached, and the wave is then refracted to Earth.

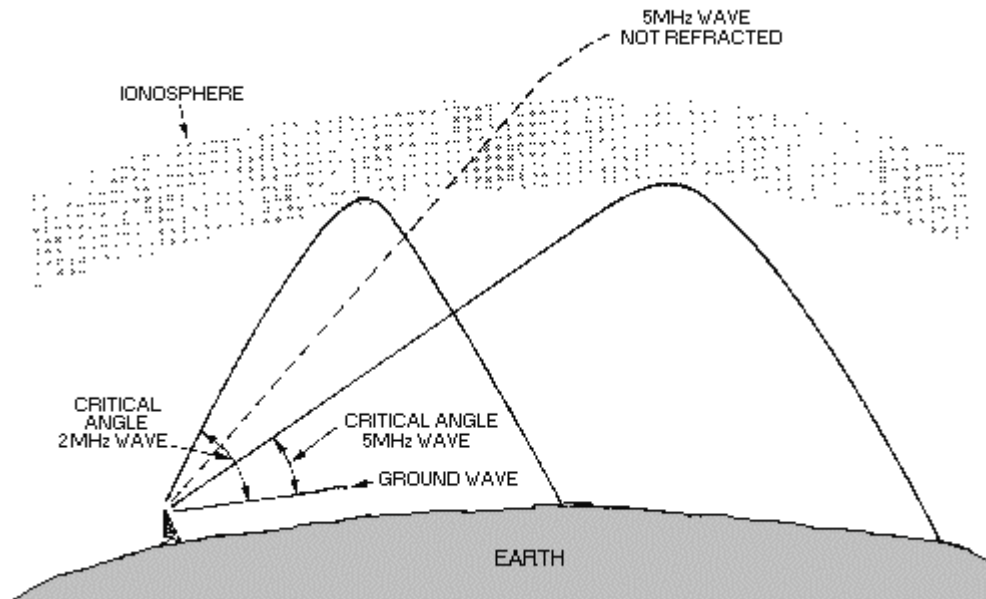

Figure 2-18.—Effects of frequency on the critical angle.

- Q20. *What factor determines whether a radio wave is reflected or refracted by the ionosphere?*
- Q21. *There is a maximum frequency at which vertically transmitted radio waves can be refracted back to Earth. What is this maximum frequency called?*
- Q22. *What three main factors determine the amount of refraction in the ionosphere?*

Skip Distance/Skip Zone

In figure 2-19, note the relationship between the sky wave skip distance, the skip zone, and the ground wave coverage. The SKIP DISTANCE is the distance from the transmitter to the point where the sky wave is first returned to Earth. The size of the skip distance depends on the frequency of the wave, the angle of incidence, and the degree of ionization present.

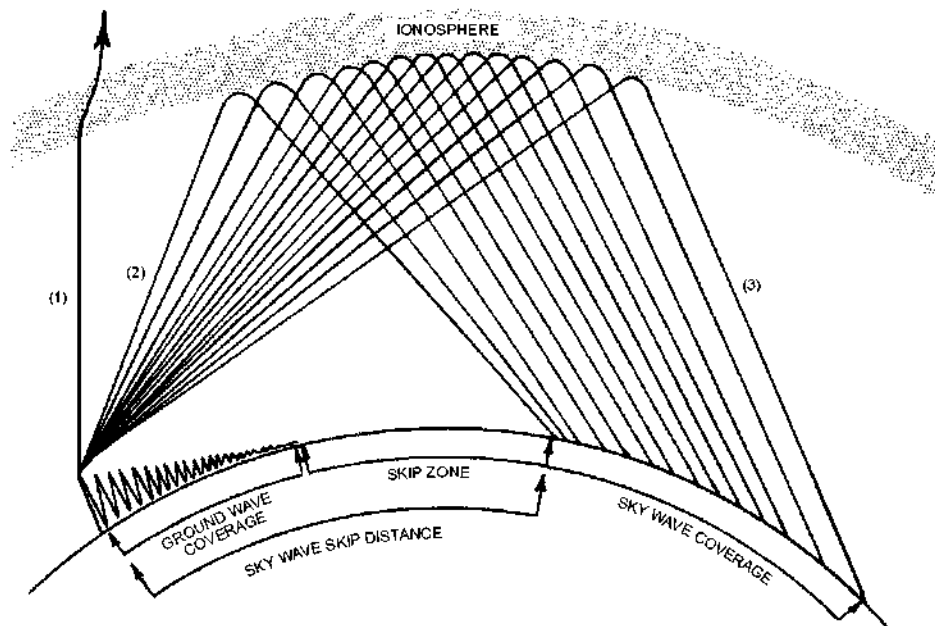

Figure 2-19.—Relationship between skip zone, skip distance, and ground wave.

The SKIP ZONE is a zone of silence between the point where the ground wave becomes too weak for reception and the point where the sky wave is first returned to Earth. The size of the skip zone depends on the extent of the ground wave coverage and the skip distance. When the ground wave coverage is great enough or the skip distance is short enough that no zone of silence occurs, there is no skip zone.

Occasionally, the first sky wave will return to Earth within the range of the ground wave. If the sky wave and ground wave are nearly of equal intensity, the sky wave alternately reinforces and cancels the ground wave, causing severe fading. This is caused by the phase difference between the two waves, a result of the longer path traveled by the sky wave.

PROPAGATION PATHS

The path that a refracted wave follows to the receiver depends on the angle at which the wave strikes the ionosphere. You should remember, however, that the rf energy radiated by a transmitting antenna spreads out with distance. The energy therefore strikes the ionosphere at many different angles rather than a single angle.

After the rf energy of a given frequency enters an ionospheric region, the paths that this energy might follow are many. It may reach the receiving antenna via two or more paths through a single layer. It

may also, reach the receiving antenna over a path involving more than one layer, by multiple hops between the ionosphere and Earth, or by any combination of these paths.

Figure 2-20 shows how radio waves may reach a receiver via several paths through one layer. The various angles at which rf energy strikes the layer are represented by dark lines and designated as rays 1 through 6.

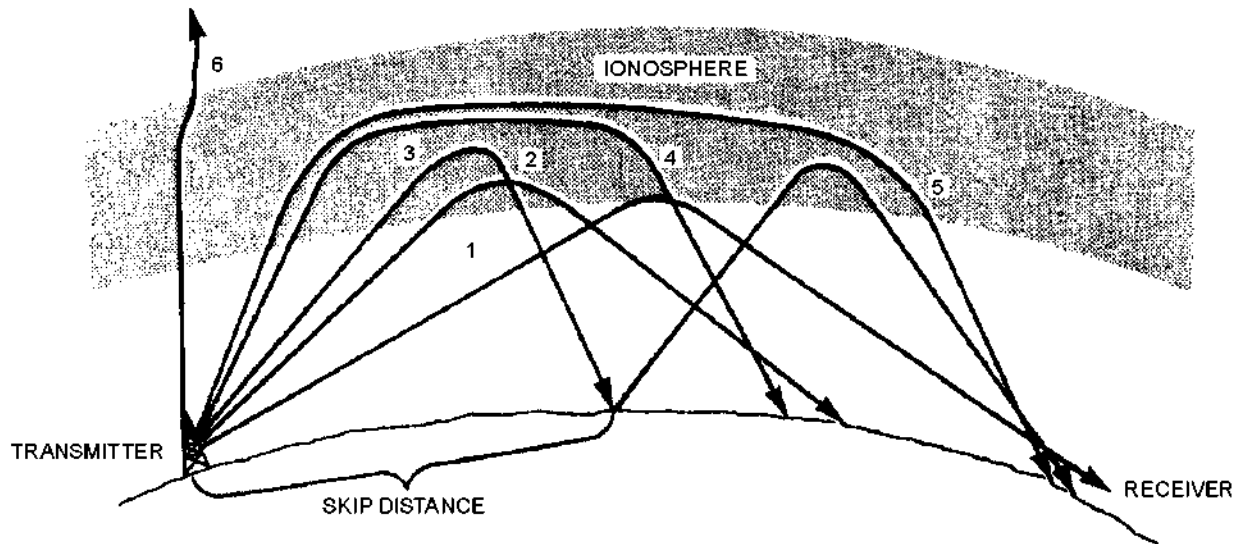

Figure 2-20.—Ray paths for a fixed frequency with varying angles of incidence.

When the angle is relatively low with respect to the horizon (ray 1), there is only slight penetration of the layer and the propagation path is long. When the angle of incidence is increased (rays 2 and 3), the rays penetrate deeper into the layer but the range of these rays decreases. When a certain angle is reached (ray 3), the penetration of the layer and rate of refraction are such that the ray is first returned to Earth at a minimal distance from the transmitter. Notice, however, that ray 3 still manages to reach the receiving site on its second refraction (called a hop) from the ionospheric layer.

As the angle is increased still more (rays 4 and 5), the rf energy penetrates the central area of maximum ionization of the layer. These rays are refracted rather slowly and are eventually returned to Earth at great distances. As the angle approaches vertical incidence (ray 6), the ray is not returned at all, but passes on through the layer.

ABSORPTION IN THE IONOSPHERE

Many factors affect a radio wave in its path between the transmitting and receiving sites. The factor that has the greatest adverse effect on radio waves is **ABSORPTION**. Absorption results in the loss of energy of a radio wave and has a pronounced effect on both the strength of received signals and the ability to communicate over long distances.

You learned earlier in the section on ground waves that surface waves suffer most of their absorption losses because of ground-induced voltage. Sky waves, on the other hand, suffer most of their absorption losses because of conditions in the ionosphere. Note that some absorption of sky waves may also occur at lower atmospheric levels because of the presence of water and water vapor. However, this becomes important only at frequencies above 10,000 megahertz.

Most ionospheric absorption occurs in the lower regions of the ionosphere where ionization density is greatest. As a radio wave passes into the ionosphere, it loses some of its energy to the free electrons and ions. If these high-energy free electrons and ions do not collide with gas molecules of low energy, most of the energy lost by the radio wave is reconverted into electromagnetic energy, and the wave continues to be propagated with little change in intensity. However, if the high-energy free electrons and ions do collide with other particles, much of this energy is lost, resulting in absorption of the energy from the wave. Since absorption of energy depends on collision of the particles, the greater the density of the ionized layer, the greater the probability of collisions; therefore, the greater the absorption. The highly dense D and E layers provide the greatest absorption of radio waves.

Because the amount of absorption of the sky wave depends on the density of the ionosphere, which varies with seasonal and daily conditions, it is impossible to express a fixed relationship between distance and signal strength for ionospheric propagation. Under certain conditions, the absorption of energy is so great that communicating over any distance beyond the line of sight is difficult.

FADING

The most troublesome and frustrating problem in receiving radio signals is variations in signal strength, most commonly known as FADING. There are several conditions that can produce fading. When a radio wave is refracted by the ionosphere or reflected from the Earth's surface, random changes in the polarization of the wave may occur. Vertically and horizontally mounted receiving antennas are designed to receive vertically and horizontally polarized waves, respectively. Therefore, changes in polarization cause changes in the received signal level because of the inability of the antenna to receive polarization changes.

Fading also results from absorption of the rf energy in the ionosphere. Absorption fading occurs for a longer period than other types of fading, since absorption takes place slowly.

Usually, however, fading on ionospheric circuits is mainly a result of multipath propagation.

Multipath Fading

MULTIPATH is simply a term used to describe the multiple paths a radio wave may follow between transmitter and receiver. Such propagation paths include the ground wave, ionospheric refraction, reradiation by the ionospheric layers, reflection from the Earth's surface or from more than one ionospheric layer, etc. Figure 2-21 shows a few of the paths that a signal can travel between two sites in a typical circuit. One path, XYZ, is the basic ground wave. Another path, XEA, refracts the wave at the E layer and passes it on to the receiver at A. Still another path, XFZFA, results from a greater angle of incidence and two refractions from the F layer. At point Z, the received signal is a combination of the ground wave and the sky wave. These two signals having traveled different paths arrive at point Z at different times. Thus, the arriving waves may or may not be in phase with each other. Radio waves that are received in phase reinforce each other and produce a stronger signal at the receiving site. Conversely, those that are received out of phase produce a weak or fading signal. Small alternations in the transmission path may change the phase relationship of the two signals, causing periodic fading. This condition occurs at point A. At this point, the double-hop F layer signal may be in or out of phase with the signal arriving from the E layer.

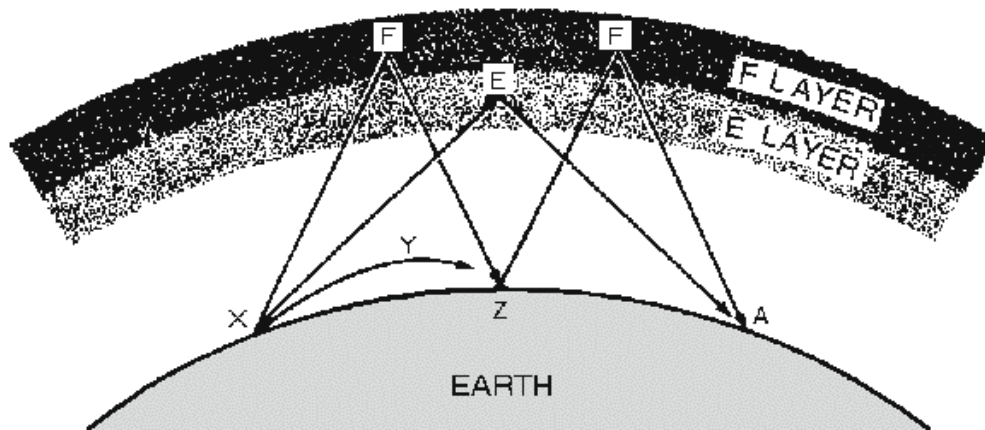

Figure 2-21.—Multipath transmission.

Multipath fading may be minimized by practices called SPACE DIVERSITY and FREQUENCY DIVERSITY. In space diversity, two or more receiving antennas are spaced some distance apart. Fading does not occur simultaneously at both antennas; therefore, enough output is almost always available from one of the antennas to provide a useful signal. In frequency diversity, two transmitters and two receivers are used, each pair tuned to a different frequency, with the same information being transmitted simultaneously over both frequencies. One of the two receivers will almost always provide a useful signal.

Selective Fading

Fading resulting from multipath propagation is variable with frequency since each frequency arrives at the receiving point via a different radio path. When a wide band of frequencies is transmitted simultaneously, each frequency will vary in the amount of fading. This variation is called SELECTIVE FADING. When selective fading occurs, all frequencies of the transmitted signal do not retain their original phases and relative amplitudes. This fading causes severe distortion of the signal and limits the total signal transmitted.

- Q23. *What is the skip zone of a radio wave?*
- Q24. *Where does the greatest amount of ionospheric absorption occur in the ionosphere?*
- Q25. *What is meant by the term "multipath"?*
- Q26. *When a wide band of frequencies is transmitted simultaneously, each frequency will vary in the amount of fading. What is this variable fading called?*

TRANSMISSION LOSSES

All radio waves propagated over ionospheric paths undergo energy losses before arriving at the receiving site. As we discussed earlier, absorption in the ionosphere and lower atmospheric levels account for a large part of these energy losses. There are two other types of losses that also significantly affect the ionospheric propagation of radio waves. These losses are known as ground reflection loss and free space loss. The combined effects of absorption, ground reflection loss, and free space loss account for most of the energy losses of radio transmissions propagated by the ionosphere.

Ground Reflection Loss

When propagation is accomplished via multihop refraction, rf energy is lost each time the radio wave is reflected from the Earth's surface. The amount of energy lost depends on the frequency of the wave, the angle of incidence, ground irregularities, and the electrical conductivity of the point of reflection.

Free space Loss

Normally, the major loss of energy is because of the spreading out of the wavefront as it travels away from the transmitter. As the distance increases, the area of the wavefront spreads out, much like the beam of a flashlight. This means the amount of energy contained within any unit of area on the wavefront will decrease as distance increases. By the time the energy arrives at the receiving antenna, the wavefront is so spread out that the receiving antenna extends into only a very small fraction of the wavefront. This is illustrated in figure 2-22.

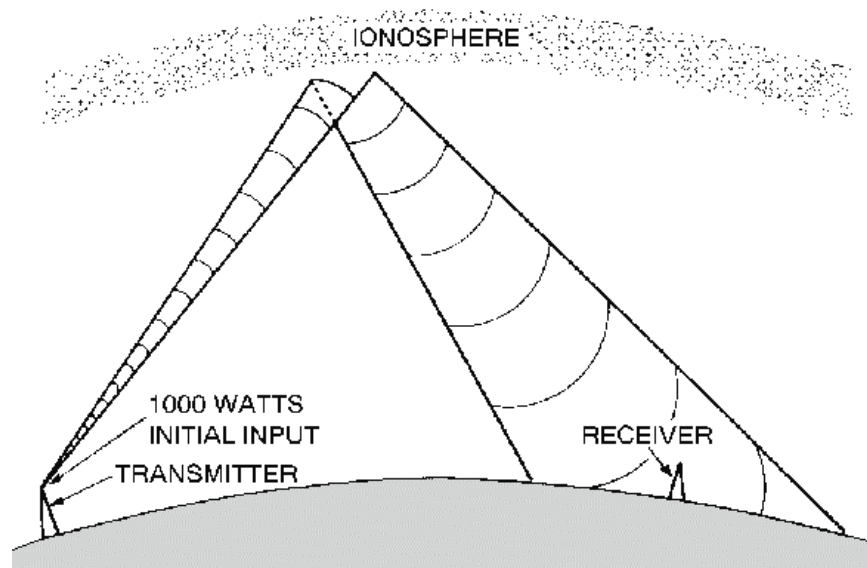

Figure 2-22.—Free space loss principle.

ELECTROMAGNETIC INTERFERENCE (EMI)

The transmission losses just discussed are not the only factors that interfere with communications. An additional factor that can interfere with radio communications is the presence of ELECTROMAGNETIC INTERFERENCE (EMI). This interference can result in annoying or impossible operating conditions. Sources of emi are both man-made and natural.

Man-Made Interference

Man-made interference may come from several sources. Some of these sources, such as oscillators, communications transmitters, and radio transmitters, may be specifically designed to generate radio frequency energy. Some electrical devices also generate radio frequency energy, although they are not specifically designed for this purpose. Examples are ignition systems, generators, motors, switches, relays, and voltage regulators. The intensity of man-made interference may vary throughout the day and drop off to a low level at night when many of these sources are not being used. Man-made interference may be a critical limiting factor at radio receiving sites located near industrial areas.

Natural Interference

Natural interference refers to the static that you often hear when listening to a radio. This interference is generated by natural phenomena, such as thunderstorms, snowstorms, cosmic sources, and the sun. The energy released by these sources is transmitted to the receiving site in roughly the same manner as radio waves. As a result, when ionospheric conditions are favorable for the long distance propagation of radio waves, they are likewise favorable for the propagation of natural interference. Natural interference is very erratic, particularly in the hf band, but generally will decrease as the operating frequency is increased and wider bandwidths are used. There is little natural interference above 30 megahertz.

Control of EMI

Electromagnetic interference can be reduced or eliminated by using various suppression techniques. The amount of emi that is produced by a radio transmitter can be controlled by cutting transmitting antennas to the correct frequency, limiting bandwidth, and using electronic filtering networks and metallic shielding.

Radiated emi during transmission can be controlled by the physical separation of the transmitting and receiving antennas, the use of directional antennas, and limiting antenna bandwidth.

Q27. What are the two main sources of emi with which radio waves must compete?

Q28. Thunderstorms, snowstorms, cosmic sources, the sun, etc., are a few examples of emi sources. What type of emi comes from these sources?

Q29. Motors, switches, voltage regulators, generators, etc., are a few examples of emi sources. What type of emi comes from these sources?

Q30. What are three ways of controlling the amount of transmitter-generated emi?

Q31. What are three ways of controlling radiated emi during transmission?

VARIATIONS IN THE IONOSPHERE

Because the existence of the ionosphere is directly related to radiations emitted from the sun, the movement of the Earth about the sun or changes in the sun's activity will result in variations in the ionosphere. These variations are of two general types: (1) those which are more or less regular and occur in cycles and, therefore, can be predicted in advance with reasonable accuracy, and (2) those which are irregular as a result of abnormal behavior of the sun and, therefore, cannot be predicted in advance. Both regular and irregular variations have important effects on radio wave propagation.

Regular Variations

The regular variations that affect the extent of ionization in the ionosphere can be divided into four main classes: daily, seasonal, 11-year, and 27-day variations.

DAILY.—Daily variations in the ionosphere are a result of the 24-hour rotation of the Earth about its axis. Daily variations of the different layers (fig. 2-14) are summarized as follows:

- The D layer reflects vlf waves; is important for long range vlf communications; refracts lf and mf waves for short range communications; absorbs hf waves; has little effect on vhf and above; and disappears at night.

- In the E layer, ionization depends on the angle of the sun. The E layer refracts hf waves during the day up to 20 megahertz to distances of about 1200 miles. Ionization is greatly reduced at night.
- Structure and density of the F region depend on the time of day and the angle of the sun. This region consists of one layer during the night and splits into two layers during daylight hours.
- Ionization density of the F1 layer depends on the angle of the sun. Its main effect is to absorb hf waves passing through to the F2 layer.
- The F2 layer is the most important layer for long distance hf communications. It is a very variable layer and its height and density change with time of day, season, and sunspot activity.

SEASONAL.—Seasonal variations are the result of the Earth revolving around the sun; the relative position of the sun moves from one hemisphere to the other with changes in seasons. Seasonal variations of the D, E, and F1 layers correspond to the highest angle of the sun; thus the ionization density of these layers is greatest during the summer. The F2 layer, however, does not follow this pattern; its ionization is greatest in winter and least in summer, the reverse of what might be expected. As a result, operating frequencies for F2 layer propagation are higher in the winter than in the summer.

ELEVEN-YEAR SUN SPOT CYCLE.—One of the most notable phenomena on the surface of the sun is the appearance and disappearance of dark, irregularly shaped areas known as SUNSPOTS. The exact nature of sunspots is not known, but scientists believe they are caused by violent eruptions on the sun and are characterized by unusually strong magnetic fields. These sunspots are responsible for variations in the ionization level of the ionosphere. Sunspots can, of course, occur unexpectedly, and the life span of individual sunspots is variable; however, a regular cycle of sunspot activity has also been observed. This cycle has both a minimum and maximum level of sunspot activity that occur approximately every 11 years.

During periods of maximum sunspot activity, the ionization density of all layers increases. Because of this, absorption in the D layer increases and the critical frequencies for the E, F1, and F2 layers are higher. At these times, higher operating frequencies must be used for long distance communications.

27-DAY SUNSPOT CYCLE.—The number of sunspots in existence at any one time is continually subject to change as some disappear and new ones emerge. As the sun rotates on its own axis, these sunspots are visible at 27-day intervals, the approximate period required for the sun to make one complete rotation.

The 27-day sunspot cycle causes variations in the ionization density of the layers on a day-to-day basis. The fluctuations in the F2 layer are greater than for any other layer. For this reason, precise predictions on a day-to-day basis of the critical frequency of the F2 layer are not possible. In calculating frequencies for long-distance communications, allowances for the fluctuations of the F2 layer must be made.

Irregular Variations

Irregular variations in ionospheric conditions also have an important effect on radio wave propagation. Because these variations are irregular and unpredictable, they can drastically affect communications capabilities without any warning.

The more common irregular variations are sporadic E, sudden ionospheric disturbances, and ionospheric storms.

SPORADIC E.—Irregular cloud-like patches of unusually high ionization, called sporadic E, often form at heights near the normal E layer. Exactly what causes this phenomenon is not known, nor can its occurrence be predicted. It is known to vary significantly with latitude, and in the northern latitudes, it appears to be closely related to the aurora borealis or northern lights.

At times the sporadic E is so thin that radio waves penetrate it easily and are returned to earth by the upper layers. At other times, it extends up to several hundred miles and is heavily ionized.

These characteristics may be either harmful or helpful to radio wave propagation. For example, sporadic E may blank out the use of higher, more favorable ionospheric layers or cause additional absorption of the radio wave at some frequencies. Also, it can cause additional multipath problems and delay the arrival times of the rays of rf energy.

On the other hand, the critical frequency of the sporadic E is very high and can be greater than double the critical frequency of the normal ionospheric layers. This condition may permit the long distance transmission of signals at unusually high frequencies. It may also permit short distance communications to locations that would normally be in the skip zone.

The sporadic E can form and disappear in a short time during either the day or night. However, it usually does not occur at the same time at all transmitting or receiving stations.

SUDDEN IONOSPHERIC DISTURBANCES.—The most startling of the ionospheric irregularities is known as a SUDDEN IONOSPHERIC DISTURBANCE (sid). These disturbances may occur without warning and may prevail for any length of time, from a few minutes to several hours. When sid occurs, long distance propagation of hf radio waves is almost totally "blanked out." The immediate effect is that radio operators listening on normal frequencies are inclined to believe their receivers have gone dead.

When sid has occurred, examination of the sun has revealed a bright solar eruption. All stations lying wholly, or in part, on the sunward side of the Earth are affected. The solar eruption produces an unusually intense burst of ultraviolet light, which is not absorbed by the F2, F1, and E layers, but instead causes a sudden abnormal increase in the ionization density of the D layer. As a result, frequencies above 1 or 2 megahertz are unable to penetrate the D layer and are usually completely absorbed by the layer.

IONOSPHERIC STORMS.—Ionospheric storms are disturbances in the Earth's magnetic field. They are associated, in a manner not fully understood, with both solar eruptions and the 27-day intervals, thus corresponding to the rotation of the sun.

Scientists believe that ionospheric storms result from particle radiation from the sun. Particles radiated from a solar eruption have a slower velocity than ultraviolet light waves produced by the eruption. This would account for the 18-hour or so time difference between a sid and an ionospheric storm. An ionospheric storm that is associated with sunspot activity may begin anytime from 2 days before an active sunspot crosses the central meridian of the sun until four days after it passes the central meridian. At times, however, active sunspots have crossed the central region of the sun without any ionospheric storms occurring. Conversely, ionospheric storms have occurred when there were no visible spots on the sun and no preceding sid. As you can see, some correlation between ionospheric storms, sid, and sunspot activity is possible, but there are no hard and fast rules. Ionospheric storms can occur suddenly without warning.

The most prominent effects of ionospheric storms are a turbulent ionosphere and very erratic sky wave propagation. Critical frequencies are lower than normal, particularly for the F2 layer. Ionospheric storms affect the higher F2 layer first, reducing its ion density. Lower layers are not appreciably affected by the storms unless the disturbance is great. The practical effect of ionospheric storms is that the range of

frequencies that can be used for communications on a given circuit is much smaller than normal, and communications are possible only at the lower working frequencies.

Q32. What are the two general types of variations in the ionosphere?

Q33. What is the main difference between these two types of variations?

Q34. What are the four main classes of regular variation which affect the extent of ionization in the ionosphere?

Q35. What are the three more common types of irregular variations in the ionosphere?

FREQUENCY SELECTION CONSIDERATIONS

Up to this point, we have covered various factors that control the propagation of radio waves through the ionosphere, such as the structure of the ionosphere, the incidence angle of radio waves, operating frequencies, etc. There is a very good reason for studying radio wave propagation. You must have a thorough knowledge of radio wave propagation to exercise good judgment when you select transmitting and receiving antennas and operating frequencies. Selection of a suitable operating frequency (within the bounds of frequency allocations and availability) is of prime importance in maintaining reliable communications.

For successful communications between any two specified locations at any given time of the day, there is a maximum frequency, a lowest frequency, and an optimum frequency that can be used.

Maximum Usable Frequency

As we discussed earlier, the higher the frequency of a radio wave, the lower the rate of refraction by an ionized layer. Therefore, for a given angle of incidence and time of day, there is a maximum frequency that can be used for communications between two given locations. This frequency is known as the MAXIMUM USABLE FREQUENCY (muf).

Waves at frequencies above the muf are normally refracted so slowly that they return to Earth beyond the desired location, or pass on through the ionosphere and are lost. You should understand, however, that use of an established muf certainly does not guarantee successful communications between a transmitting site and a receiving site. Variations in the ionosphere may occur at any time and consequently raise or lower the predetermined muf. This is particularly true for radio waves being refracted by the highly variable F2 layer.

The muf is highest around noon when ultraviolet light waves from the sun are the most intense. It then drops rather sharply as recombination begins to take place.

Lowest Usable Frequency

As there is a maximum operating frequency that can be used for communications between two points, there is also a minimum operating frequency. This is known as the LOWEST USABLE FREQUENCY (luf).

As the frequency of a radio wave is lowered, the rate of refraction increases. So a wave whose frequency is below the established luf is refracted back to Earth at a shorter distance than desired, as shown in figure 2-23.

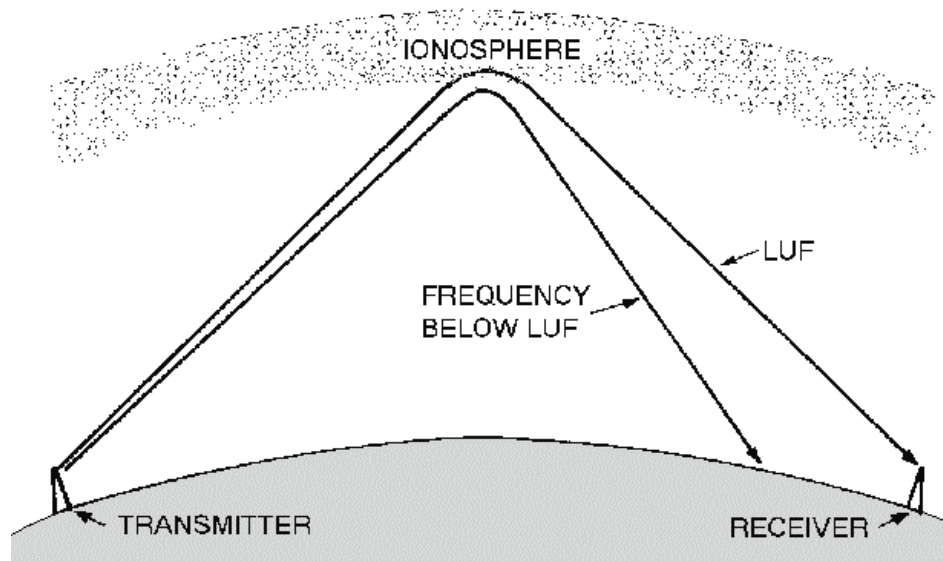

Figure 2-23.—Refraction of frequency below the lowest usable frequency (luf).

The transmission path that results from the rate of refraction is not the only factor that determines the luf. As a frequency is lowered, absorption of the radio wave increases. A wave whose frequency is too low is absorbed to such an extent that it is too weak for reception. Likewise, atmospheric noise is greater at lower frequencies; thus, a low-frequency radio wave may have an unacceptable signal-to-noise ratio.

For a given angle of incidence and set of ionospheric conditions, the luf for successful communications between two locations depends on the refraction properties of the ionosphere, absorption considerations, and the amount of atmospheric noise present.

Optimum Working Frequency

Neither the muf nor the luf is a practical operating frequency. While radio waves at the luf can be refracted back to Earth at the desired location, the signal-to-noise ratio is still much lower than at the higher frequencies, and the probability of multipath propagation is much greater. Operating at or near the muf can result in frequent signal fading and dropouts when ionospheric variations alter the length of the transmission path.

The most practical operating frequency is one that you can rely on with the least amount of problems. It should be high enough to avoid the problems of multipath, absorption, and noise encountered at the lower frequencies; but not so high as to result in the adverse effects of rapid changes in the ionosphere.

A frequency that meets the above criteria has been established and is known as the OPTIMUM WORKING FREQUENCY. It is abbreviated "fot" from the initial letters of the French words for optimum working frequency, "frequence optimum de travail." The fot is roughly about 85 percent of the muf but the actual percentage varies and may be either considerably more or less than 85 percent.

Q36. What do the letters muf, luf, and fot stand for?

Q37. When is muf at its highest and why?

Q38. What happens to the radio wave if the luf is too low?

Q39. What are some disadvantages of operating transmitters at or near the luf?

Q40. What are some disadvantages of operating a transmitter at or near the muf?

Q41. What is fot?

WEATHER VERSUS PROPAGATION

Weather is an additional factor that affects the propagation of radio waves. In this section, we will explain how and to what extent the various weather phenomena affect wave propagation.

Wind, air temperature, and water content of the atmosphere can combine in many ways. Certain combinations can cause radio signals to be heard hundreds of miles beyond the ordinary range of radio communications. Conversely, a different combination of factors can cause such attenuation of the signal that it may not be heard even over a normally satisfactory path. Unfortunately, there are no hard and fast rules on the effects of weather on radio transmissions since the weather is extremely complex and subject to frequent change. We will, therefore, limit our discussion on the effects of weather on radio waves to general terms.

PRECIPITATION ATTENUATION

Calculating the effect of weather on radio wave propagation would be comparatively simple if there were no water or water vapor in the atmosphere. However, some form of water (vapor, liquid, or solid) is always present and must be considered in all calculations. Before we begin discussing the specific effects that individual forms of precipitation (rain, snow, fog) have on radio waves, you should understand that attenuation because of precipitation is generally proportionate to the frequency and wavelength of the radio wave. For example, rain has a pronounced effect on waves at microwave frequencies. However, rain hardly affects waves with long wavelengths (hf range and below). You can assume, then, that as the wavelength becomes shorter with increases in frequency, precipitation has an increasingly important attenuation effect on radio waves. Conversely, you can assume that as the wavelength becomes longer with decreases in frequency, precipitation has little attenuation effect.

Rain

Attenuation because of raindrops is greater than attenuation because of other forms of precipitation. Attenuation may be caused by absorption, in which the raindrop, acting as a poor dielectric, absorbs power from the radio wave and dissipates the power by heat loss or by scattering (fig. 2-24). Raindrops cause greater attenuation by scattering than by absorption at frequencies above 100 megahertz. At frequencies above 6 gigahertz, attenuation by raindrop scatter is even greater.

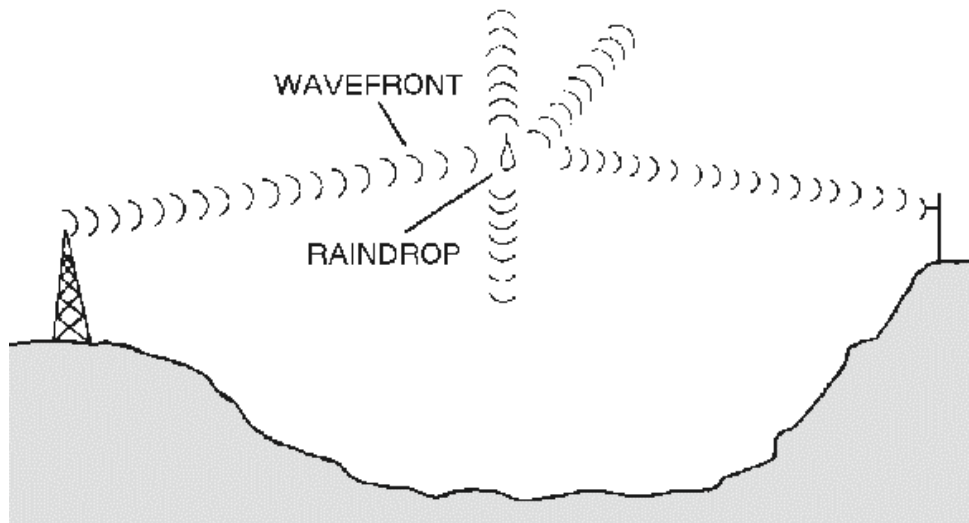

Figure 2-24.—Rf energy losses from scattering.

Fog

In the discussion of attenuation, fog may be considered as another form of rain. Since fog remains suspended in the atmosphere, the attenuation is determined by the quantity of water per unit volume and by the size of the droplets. Attenuation because of fog is of minor importance at frequencies lower than 2 gigahertz. However, fog can cause serious attenuation by absorption, at frequencies above 2 gigahertz.

Snow

The scattering effect because of snow is difficult to compute because of irregular sizes and shapes of the flakes. While information on the attenuating effect of snow is limited, scientists assume that attenuation from snow is less than from rain falling at an equal rate. This assumption is borne out by the fact that the density of rain is eight times the density of snow. As a result, rain falling at 1 inch per hour would have more water per cubic inch than snow falling at the same rate.

Hail

Attenuation by hail is determined by the size of the stones and their density. Attenuation of radio waves by scattering because of hailstones is considerably less than by rain.

TEMPERATURE INVERSION

Under normal atmospheric conditions, the warmest air is found near the surface of the Earth. The air gradually becomes cooler as altitude increases. At times, however, an unusual situation develops in which layers of warm air are formed above layers of cool air. This condition is known as TEMPERATURE INVERSION. These temperature inversions cause channels, or ducts, of cool air to be sandwiched between the surface of the Earth and a layer of warm air, or between two layers of warm air.

If a transmitting antenna extends into such a duct of cool air, or if the radio wave enters the duct at a very low angle of incidence, vhf and uhf transmissions may be propagated far beyond normal line-of-sight distances. When ducts are present as a result of temperature inversions, good reception of vhf and uhf television signals from a station located hundreds of miles away is not unusual. These long

distances are possible because of the different densities and refractive qualities of warm and cool air. The sudden change in density when a radio wave enters the warm air above a duct causes the wave to be refracted back toward Earth. When the wave strikes the Earth or a warm layer below the duct, it is again reflected or refracted upward and proceeds on through the duct with a multiple-hop type of action. An example of the propagation of radio waves by ducting is shown in figure 2-25.

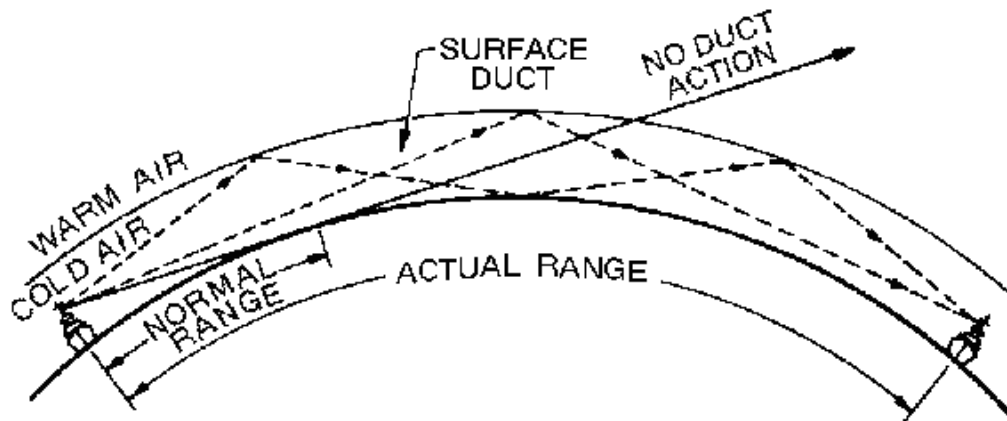

Figure 2-25.—Duct effect caused by temperature inversion.

- Q42. How do raindrops affect radio waves?
- Q43. How does fog affect radio waves at frequencies above 2 gigahertz?
- Q44. How is the term "temperature inversion" used when referring to radio waves?
- Q45. How does temperature inversion affect radio transmission?

TROPOSPHERIC PROPAGATION

As the lowest region of the Earth's atmosphere, the troposphere extends from the Earth's surface to a height of slightly over 7 miles. Virtually all weather phenomena occur in this region. Generally, the troposphere is characterized by a steady decrease in both temperature and pressure as height is increased. However, the many changes in weather phenomena cause variations in humidity and an uneven heating of the Earth's surface. As a result, the air in the troposphere is in constant motion. This motion causes small turbulences, or eddies, to be formed, as shown by the bouncing of aircraft entering turbulent areas of the atmosphere. These turbulences are most intense near the Earth's surface and gradually diminish with height. They have a refractive quality that permits the refracting or scattering of radio waves with short wavelengths. This scattering provides enhanced communications at higher frequencies.

Recall that in the relationship between frequency and wavelength, wavelength decreases as frequency increases and vice versa. Radio waves of frequencies below 30 megahertz normally have wavelengths longer than the size of weather turbulences. These radio waves are, therefore, affected very little by the turbulences. On the other hand, as the frequency increases into the vhf range and above, the wavelengths decrease in size, to the point that they become subject to tropospheric scattering. The usable frequency range for tropospheric scattering is from about 100 megahertz to 10 gigahertz.

TROPOSPHERIC SCATTERING

When a radio wave passing through the troposphere meets a turbulence, it makes an abrupt change in velocity. This causes a small amount of the energy to be scattered in a forward direction and returned to Earth at distances beyond the horizon. This phenomenon is repeated as the radio wave meets other turbulences in its path. The total received signal is an accumulation of the energy received from each of the turbulences.

This scattering mode of propagation enables vhf and uhf signals to be transmitted far beyond the normal line-of-sight. To better understand how these signals are transmitted over greater distances, you must first consider the propagation characteristics of the space wave used in vhf and uhf line-of-sight communications. When the space wave is transmitted, it undergoes very little attenuation within the line-of-sight horizon. When it reaches the horizon, the wave is diffracted and follows the Earth's curvature. Beyond the horizon, the rate of attenuation increases very rapidly and signals soon become very weak and unusable.

Tropospheric scattering, on the other hand, provides a usable signal at distances beyond the point where the diffracted space wave drops to an unusable level. This is because of the height at which scattering takes place. The turbulence that causes the scattering can be visualized as a relay station located above the horizon; it receives the transmitted energy and then reradiates it in a forward direction to some point beyond the line-of-sight distance. A high gain receiving antenna aimed toward this scattered energy can then capture it.

The magnitude of the received signal depends on the number of turbulences causing scatter in the desired direction and the gain of the receiving antenna. The scatter area used for tropospheric scatter is known as the *scatter volume*. The angle at which the receiving antenna must be aimed to capture the scattered energy is called the *scatter angle*. The scatter volume and scatter angle are shown in figure 2-26.

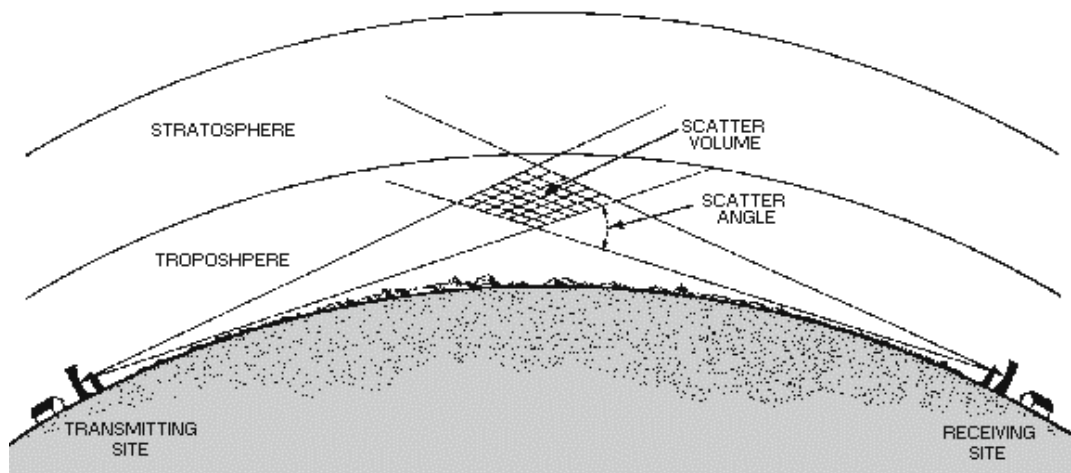

Figure 2-26.—Tropospheric scattering propagation.

The signal take-off angle (transmitting antenna's angle of radiation) determines the height of the scatter volume and the size of the scatter angle. A low signal take-off angle produces a low scatter volume, which in turn permits a receiving antenna that is aimed at a low angle to the scatter volume to capture the scattered energy.

As the signal take-off angle is increased, the height of the scatter volume is increased. When this occurs, the amount of received energy decreases. There are two reasons for this: (1) scatter angle

increases as the height of the scatter volume is increased; (2) the amount of turbulence decreases with height. As the distance between the transmitting and receiving antennas is increased, the height of the scatter volume must also be increased. The received signal level, therefore, decreases as circuit distance is increased.

The tropospheric region that contributes most strongly to tropospheric scatter propagation lies near the midpoint between the transmitting and receiving antennas and just above the radio horizon of the antennas.

Since tropospheric scatter depends on turbulence in the atmosphere, changes in atmospheric conditions have an effect on the strength of the received signal. Both daily and seasonal variations in signal strength occur as a result of changes in the atmosphere. These variations are called *long-term fading*.

In addition to long-term fading, the tropospheric scatter signal often is characterized by very rapid fading because of multipath propagation. Since the turbulent condition is constantly changing, the path lengths and individual signal levels are also changing, resulting in a rapidly changing signal. Although the signal level of the received signal is constantly changing, the average signal level is stable; therefore, no complete fade out occurs.

Another characteristic of a tropospheric scatter signal is its relatively low power level. Since very little of the scattered energy is reradiated toward the receiver, the efficiency is very low and the signal level at the final receiver point is low. Initial input power must be high to compensate for the low efficiency in the scatter volume. This is accomplished by using high-power transmitters and high-gain antennas, which concentrate the transmitted power into a beam, thus increasing the intensity of energy of each turbulence in the volume. The receiver must also be very sensitive to detect the low-level signals.

APPLICATION OF TROPOSPHERIC SCATTERING

Tropospheric scatter propagation is used for point-to-point communications. A correctly designed tropospheric scatter circuit will provide highly reliable service for distances ranging from 50 miles to 500 miles. Tropospheric scatter systems may be particularly useful for communications to locations in rugged terrain that are difficult to reach with other methods of propagation. One reason for this is that the tropospheric scatter circuit is not affected by ionospheric and auroral disturbances.

Q46. In what layer of the atmosphere does virtually all weather phenomena occur?

Q47. Which radio frequency bands use the tropospheric scattering principle for propagation of radio waves?

Q48. Where is the tropospheric region that contributes most strongly to tropospheric scatter propagation?

SUMMARY

Now that you have completed this chapter, let's review some of the new terms, concepts, and ideas that you have learned. You should have a thorough understanding of these principles before moving on to chapter 3.

The **INDUCTION FIELD** contains an E field and an H field and is localized near the antenna. The E and H fields of the induction field are 90 degrees out of phase with each other.

The **RADIATION FIELD** contains E and H fields that are propagated from the antenna into space in the form of electromagnetic waves. The E and H fields of the radiation field are in phase with each other.

A **HARMONIC FREQUENCY** is any frequency that is a whole number multiple of a smaller basic frequency. For example, a radio wave transmitted at a fundamental frequency of 3000 hertz can have a second harmonic of 6000 hertz, a third harmonic frequency of 9000 hertz, etc., transmitted at the same time.

A **VERTICALLY POLARIZED** antenna transmits an electromagnetic wave with the E field perpendicular to the Earth's surface. A **HORIZONTALLY POLARIZED** antenna transmits a radio wave with the E field parallel to the Earth's surface.

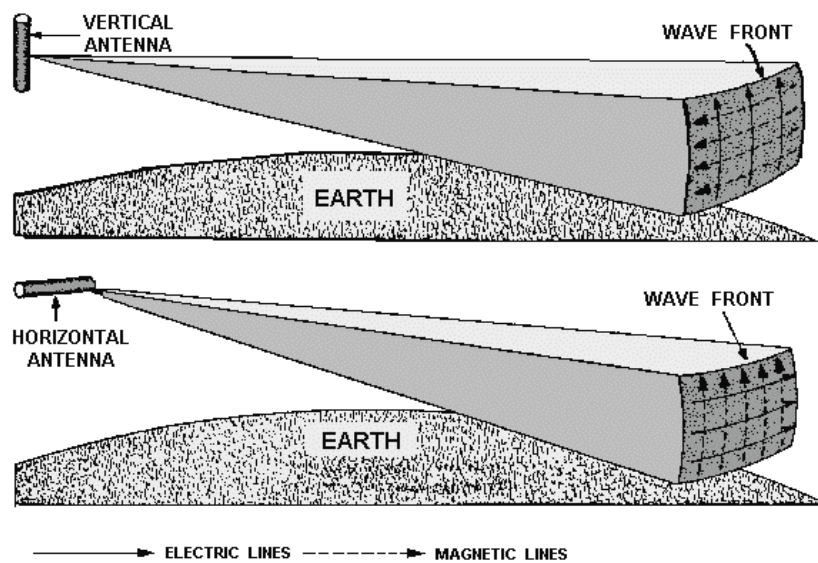

A **WAVEFRONT** is a small section of an expanding sphere of radiated energy and is perpendicular to the direction of travel from the antenna.

RADIO WAVES are electromagnetic waves that can be reflected, refracted, and diffracted in the atmosphere like light and heat waves.

REFLECTED RADIO WAVES are waves that have been reflected from a surface and are 180 degrees out of phase with the initial wave.

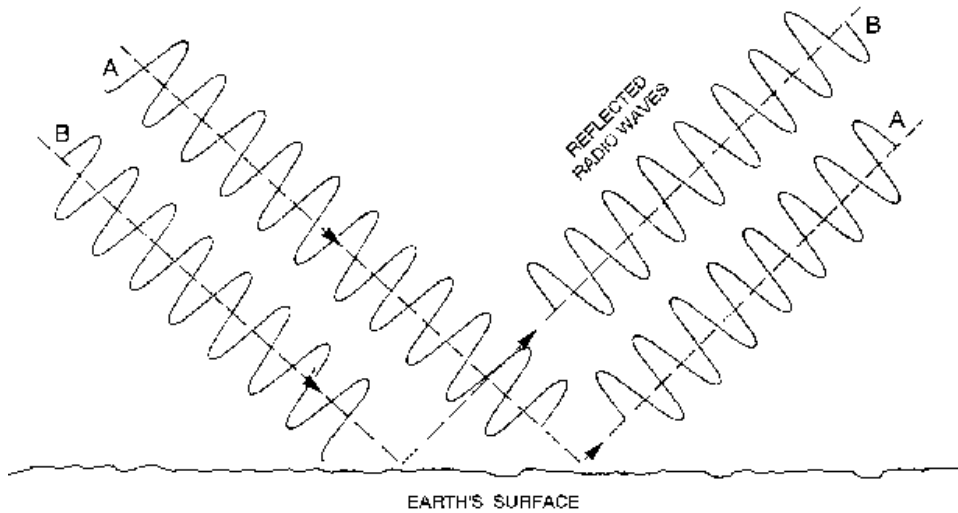

The Earth's atmosphere is divided into three separate layers: The **TROPOSPHERE**, **STRATOSPHERE**, and **IONOSPHERE**.

The **TROPOSPHERE** is the region of the atmosphere where virtually all weather phenomena take place. In this region, rf energy is greatly affected.

The **STRATOSPHERE** has a constant temperature and has little effect on radio waves.

The **IONOSPHERE** contains four cloud-like layers of electrically charged ions which aid in long distance communications.

GROUND WAVES and **SKY WAVES** are the two basic types of radio waves that transmit energy from the transmitting antenna to the receiving antenna.

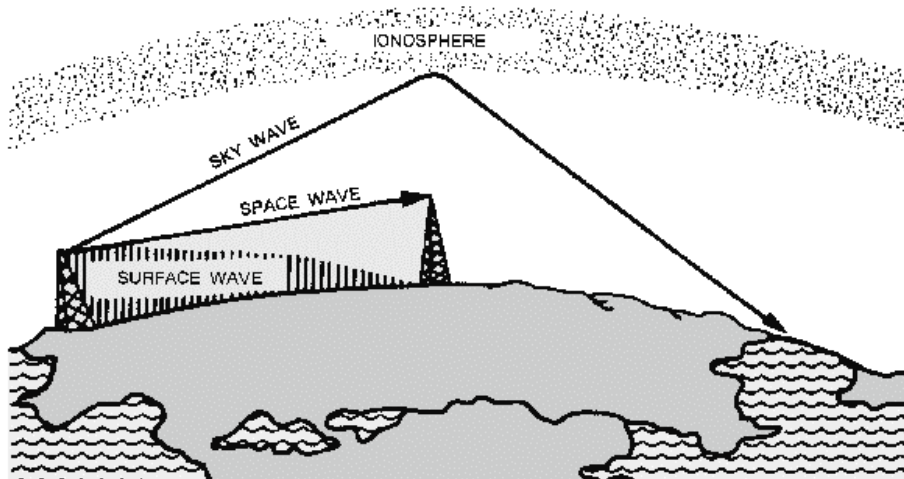

GROUND WAVES are composed of two separate component waves: the **SURFACE WAVE** and the **SPACE WAVE**.

SURFACE WAVES travel along the contour of the Earth by diffraction.

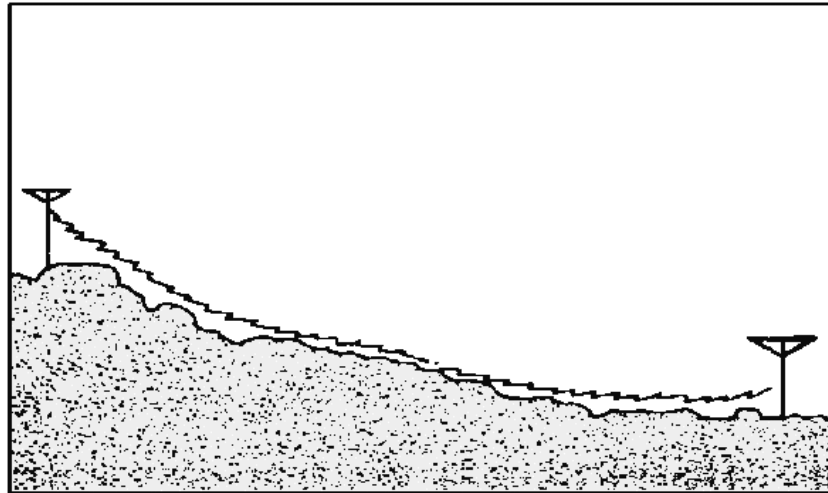

SPACE WAVES can travel through the air directly to the receiving antenna or can be reflected from the surface of the Earth.

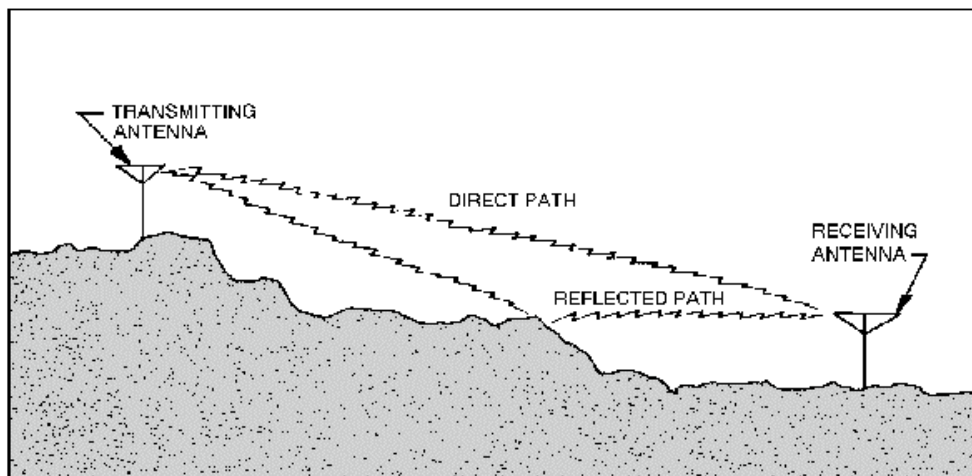

SKY WAVES, often called ionospheric waves, are radiated in an upward direction and returned to Earth at some distant location because of refraction.

NATURAL HORIZON is the line-of-sight horizon.

RADIO HORIZON is one-third farther than the natural horizon.

The **IONOSPHERE** consists of several layers of ions, formed by the process called ionization.

IONIZATION is the process of knocking electrons free from their parent atom, thus upsetting electrical neutrality.

RECOMBINATION is the opposite of ionization; that is, the free ions combine with positive ions, causing the positive ions to return to their original neutral atom state.

The **D LAYER** is the lowest region of the ionosphere and refracts signals of low frequencies back to Earth.

The **E LAYER** is present during the daylight hours; refracts signals as high as 20 megahertz back to Earth; and is used for communications up to 1500 miles.

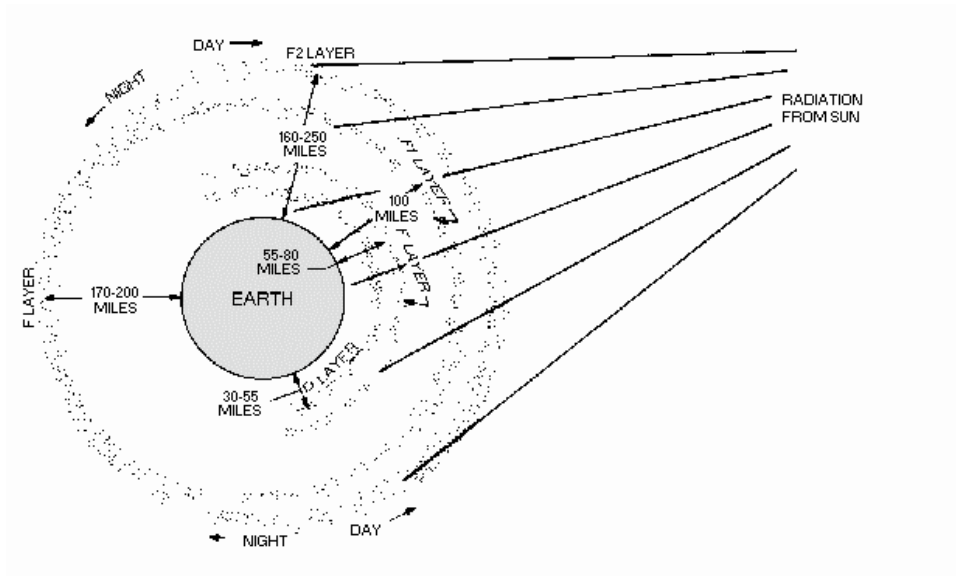

The **F LAYER** is divided into the F1 and F2 layers during the day but combine at night to form one layer. This layer is responsible for high-frequency, long-range transmission.

The **CRITICAL FREQUENCY** is the maximum frequency that a radio wave can be transmitted vertically and still be refracted back to Earth.

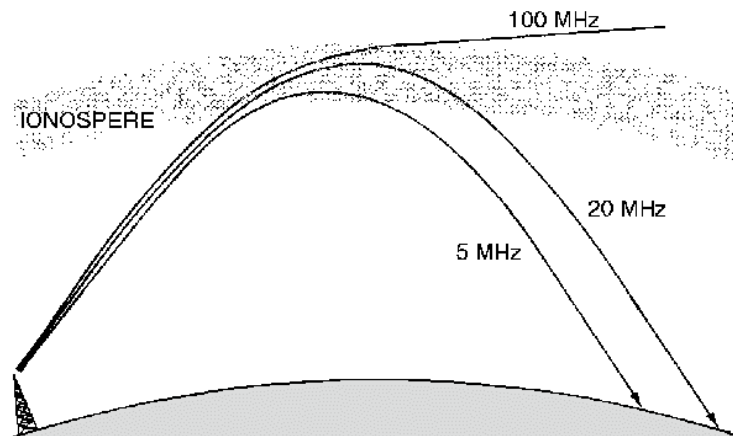

The **CRITICAL ANGLE** is the maximum and/or minimum angle that a radio wave can be transmitted and still be refracted back to Earth.

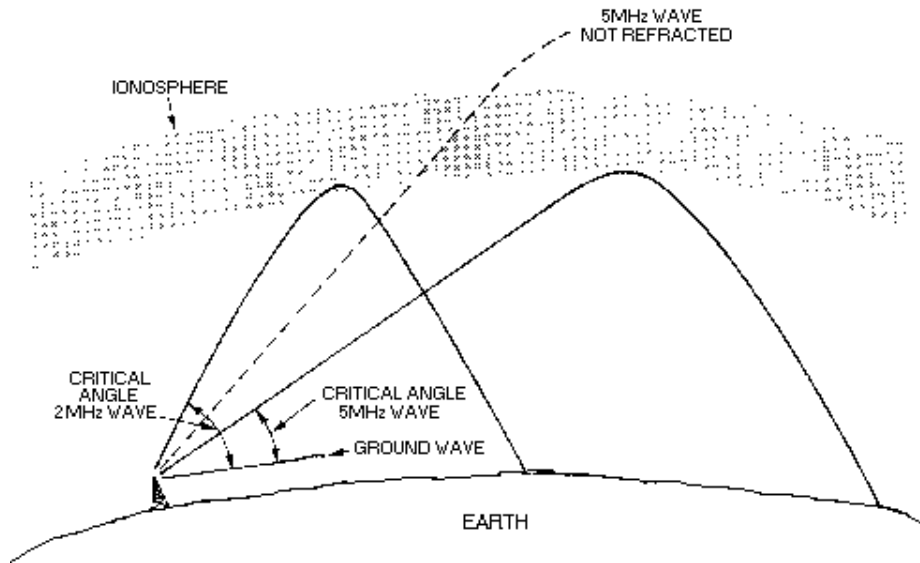

SKIP DISTANCE is the distance between the transmitter and the point where the sky wave first returns to Earth.

SKIP ZONE is the zone of silence between the point where the ground wave becomes too weak for reception and the point where the sky wave is first returned to Earth.

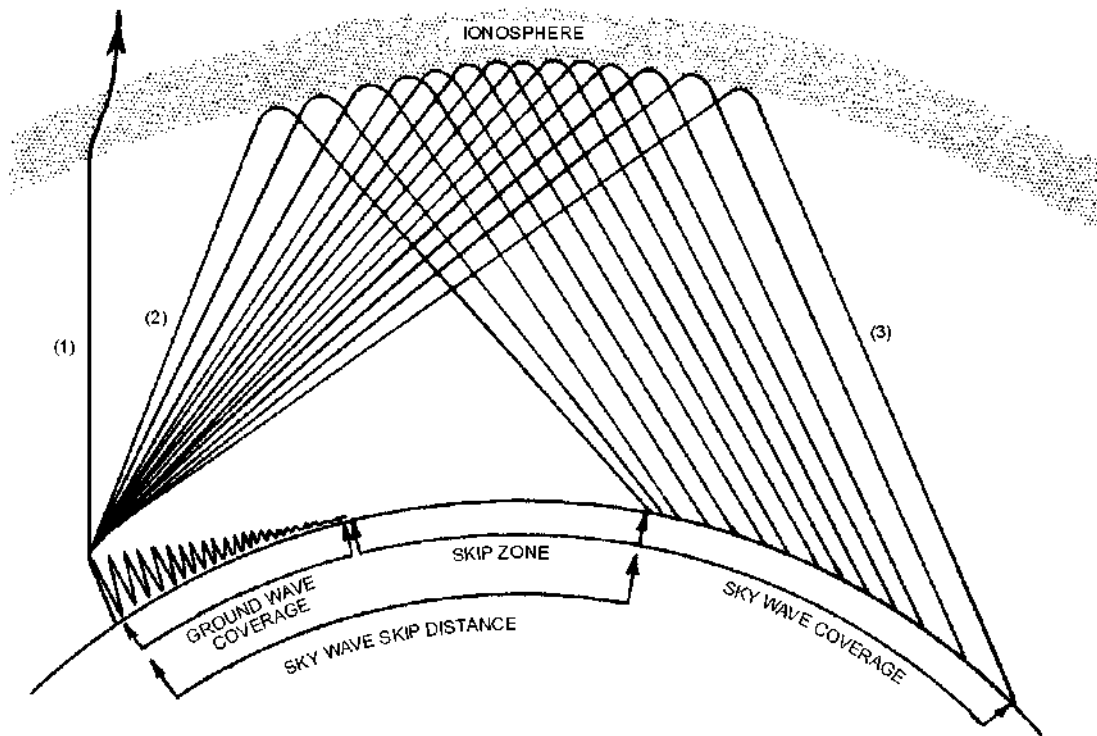

FADING is caused by variations in signal strength, such as absorption of the rf energy by the ionosphere.

MULTIPATH FADING occurs when a transmitted signal divides and takes more than one path to a receiver and some of the signals arrive out of phase, resulting in a weak or fading signal.

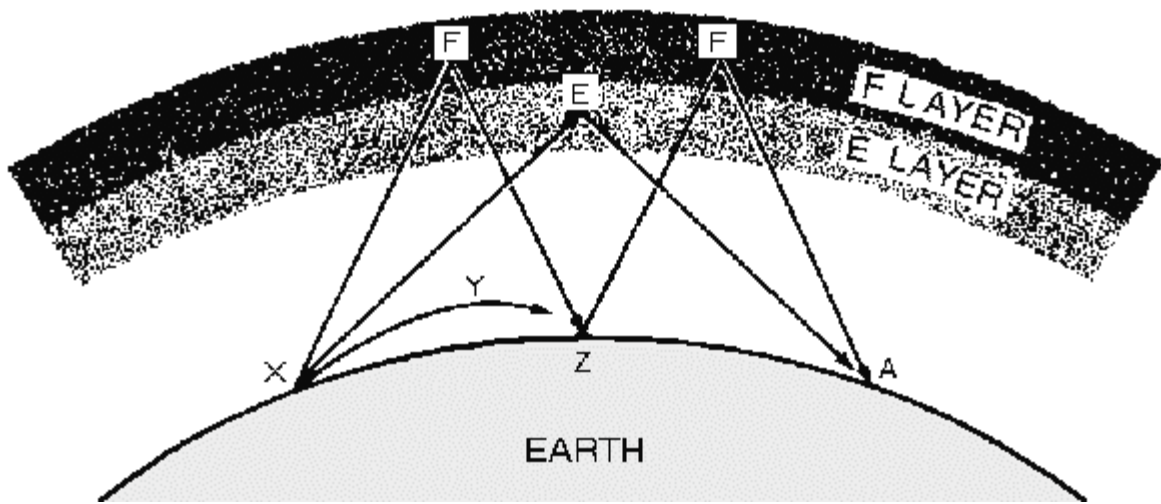

Some **TRANSMISSION LOSSES** that affect radio-wave propagation are ionospheric absorption, ground reflection, and free-space losses.

ELECTROMAGNETIC INTERFERENCE (emi), both natural and man-made, interfere with radio communications.

The **MAXIMUM USABLE FREQUENCY (muf)** is the highest frequency that can be used for communications between two locations at a given angle of incidence and time of day.

The **LOWEST USABLE FREQUENCY (luf)** is the lowest frequency that can be used for communications between two locations.

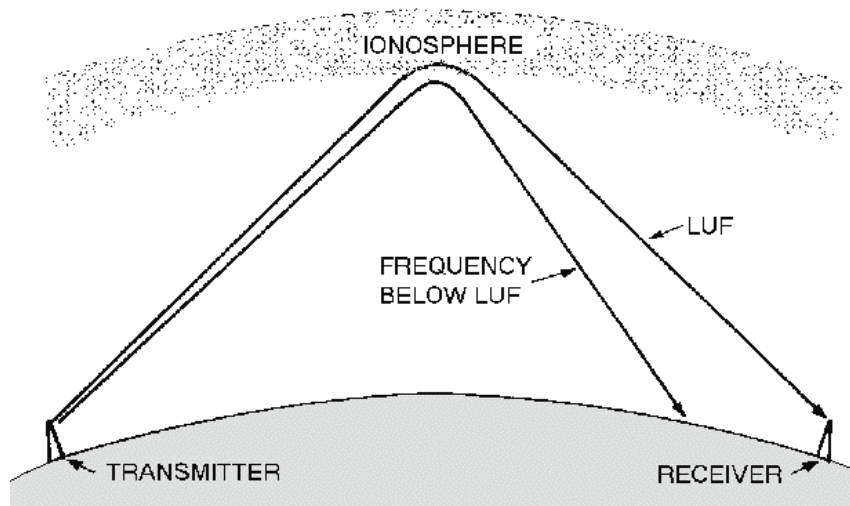

OPTIMUM WORKING FREQUENCY (fof) is the most practical operating frequency and the one that can be relied on to have the fewest problems.

PRECIPITATION ATTENUATION can be caused by rain, fog, snow, and hail; and can affect overall communications considerably.

TEMPERATURE INVERSION causes channels, or ducts, of cool air to form between layers of warm air, which can cause radio waves to travel far beyond the normal line-of-sight distances.

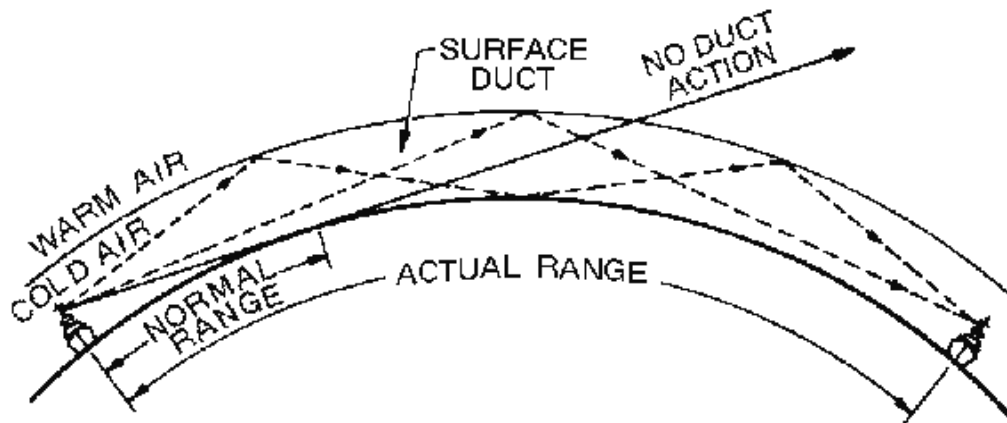

TROPOSPHERIC PROPAGATION uses the scattering principle to achieve beyond the line-of-sight radio communications within the troposphere.

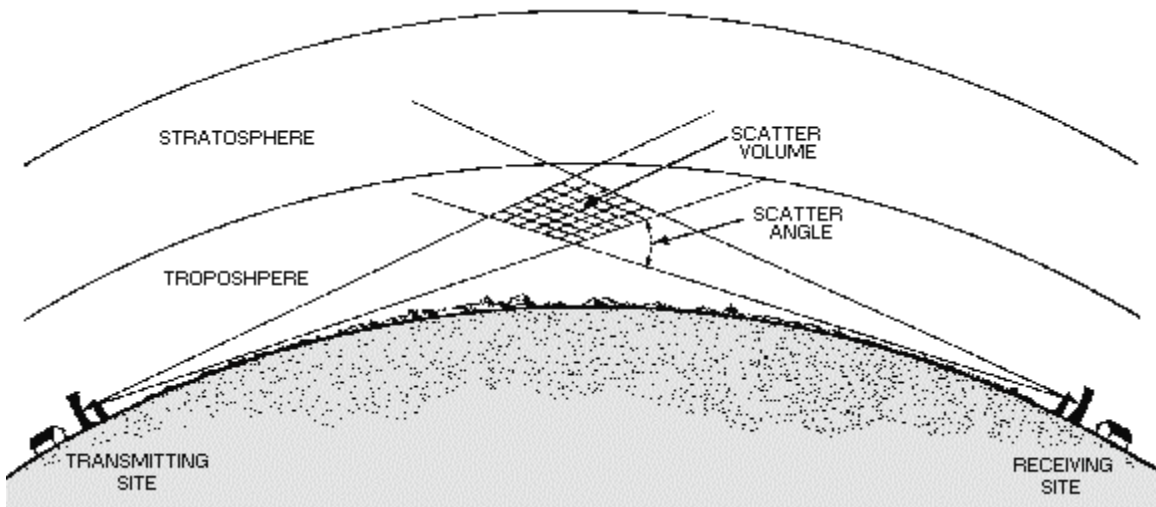

ANSWERS TO QUESTIONS Q1. THROUGH Q48.

- A1. *Induction field and radiation field.*
- A2. *Induction field.*
- A3. *Radiation field.*
- A4. *Fundamental frequency.*
- A5. *Harmonic frequency or harmonics.*
- A6. *30 meters.*
- A7. *5 megahertz.*
- A8. *Vertically polarized.*
- A9. *Direction of wave propagation.*
- A10. *Shifting in the phase relationships of the wave.*
- A11. *Troposphere, stratosphere, and ionosphere.*
- A12. *Stratosphere.*
- A13. *Whether the component of the wave is travelling along the surface or over the surface of the earth.*
- A14. *Radio horizon is about 1/3 farther.*
- A15. *Sea water.*
- A16. *(a) electrical properties of the terrain (b) frequency (c) polarization of the antenna*
- A17. *High energy ultraviolet light waves from the sun.*
- A18. *D, E, F₁, and F₂ layers.*
- A19. *D layer is 30-55 miles, E layer 55-90 miles, and F layers are 90-240 miles.*
- A20. *Thickness of ionized layer.*
- A21. *Critical frequency.*
- A22. *(a) density of ionization of the layer (b) frequency (c) angle at which it enters the layer*
- A23. *A zone of silence between the ground wave and sky wave where there is no reception.*
- A24. *Where ionization density is greatest.*
- A25. *A term used to describe the multiple pattern a radio wave may follow.*
- A26. *Selective fading.*
- A27. *Natural and man-made interference.*

- A28. *Natural.*
- A29. *Man-made.*
- A30. *(a) filtering and shielding of the transmitter (b) limiting bandwidth (c) cutting the antenna to the correct frequency*
- A31. *(a) physical separation of the antenna (b) limiting bandwidth of the antenna (c) use of directional antennas*
- A32. *Regular and irregular variations.*
- A33. *Regular variations can be predicted but irregular variations are unpredictable.*
- A34. *Daily, seasonal, 11-year, and 27-days variation.*
- A35. *Sporadic E, sudden disturbances, and ionospheric storms.*
- A36. *Muf is maximum usable frequency. Luf is lowest usable frequency. Fot is commonly known as optimum working frequency.*
- A37. *Muf is highest around noon. Ultraviolet light waves from the sun are most intense.*
- A38. *When luf is too low it is absorbed and is too weak for reception.*
- A39. *Signal-to-noise ratio is low and the probability of multipath propagation is greater.*
- A40. *Frequent signal fading and dropouts.*
- A41. *Fot is the most practical operating frequency that can be relied on to avoid problems of multipath, absorption, and noise.*
- A42. *They can cause attenuation by scattering.*
- A43. *It can cause attenuation by absorption.*
- A44. *It is a condition where layers of warm air are formed above layers of cool air.*
- A45. *It can cause vhf and uhf transmission to be propagated far beyond normal line-of-sight distances.*
- A46. *Troposphere.*
- A47. *Vhf and above.*
- A48. *Near the mid-point between the transmitting and receiving antennas, just above the radio horizon.*

CHAPTER 3

PRINCIPLES OF TRANSMISSION LINES

LEARNING OBJECTIVES

Upon completion of this chapter, you will be able to:

1. State what a transmission line is and how transmission lines are used.
2. Explain the operating principles of transmission lines.
3. Describe the five types of transmission lines.
4. State the length of a transmission line.
5. Explain the theory of the transmission line.
6. Define the term LUMPED CONSTANTS in relation to a transmission line.
7. Define the term DISTRIBUTED CONSTANTS in relation to a transmission line.
8. Define LEAKAGE CURRENT.
9. Describe how the electromagnetic lines of force around a transmission line are affected by the distributed constants.
10. Define the term CHARACTERISTIC IMPEDANCE and explain how it affects the transfer of energy along a transmission line.
11. State how the energy transfer along a transmission line is affected by characteristic impedance and the infinite line.
12. Identify the cause of and describe the characteristics of reflections on a transmission line.
13. Define the term STANDING WAVES as applied to a transmission line.
14. Describe how standing waves are produced on a transmission line and identify the types of terminations.
15. Describe the types of standing-wave ratios.

INTRODUCTION TO TRANSMISSION LINES

A TRANSMISSION LINE is a device designed to guide electrical energy from one point to another. It is used, for example, to transfer the output rf energy of a transmitter to an antenna. This energy will not travel through normal electrical wire without great losses. Although the antenna can be connected directly to the transmitter, the antenna is usually located some distance away from the transmitter. On board ship,

the transmitter is located inside a radio room and its associated antenna is mounted on a mast. A transmission line is used to connect the transmitter and the antenna.

The transmission line has a single purpose for both the transmitter and the antenna. This purpose is to transfer the energy output of the transmitter to the antenna with the least possible power loss. How well this is done depends on the special physical and electrical characteristics (impedance and resistance) of the transmission line.

TERMINOLOGY

All transmission lines have two ends (see figure 3-1). The end of a two-wire transmission line connected to a source is ordinarily called the INPUT END or the GENERATOR END. Other names given to this end are TRANSMITTER END, SENDING END, and SOURCE. The other end of the line is called the OUTPUT END or RECEIVING END. Other names given to the output end are LOAD END and SINK.

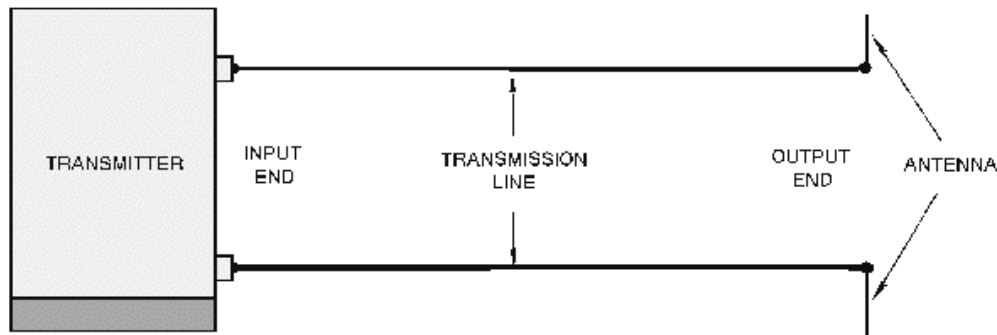

Figure 3-1.—Basic transmission line.

You can describe a transmission line in terms of its impedance. The ratio of voltage to current (E_{in}/I_{in}) at the input end is known as the INPUT IMPEDANCE (Z_{in}). This is the impedance presented to the transmitter by the transmission line and its load, the antenna. The ratio of voltage to current at the output (E_{out}/I_{out}) end is known as the OUTPUT IMPEDANCE (Z_{out}). This is the impedance presented to the load by the transmission line and its source. If an infinitely long transmission line could be used, the ratio of voltage to current at any point on that transmission line would be some particular value of impedance. This impedance is known as the CHARACTERISTIC IMPEDANCE.

- Q1. What connecting link is used to transfer energy from a radio transmitter to its antenna located on the mast of a ship?*
- Q2. What term is used for the end of the transmission line that is connected to a transmitter?*
- Q3. What term is used for the end of the transmission line that is connected to an antenna?*

TYPES OF TRANSMISSION MEDIUMS

The Navy uses many different types of TRANSMISSION MEDIUMS in its electronic applications. Each medium (line or wave guide) has a certain characteristic impedance value, current-carrying capacity, and physical shape and is designed to meet a particular requirement.

The five types of transmission mediums that we will discuss in this chapter include PARALLEL-LINE, TWISTED PAIR, SHIELDED PAIR, COAXIAL LINE, and WAVEGUIDES. The use of a particular line depends, among other things, on the applied frequency, the power-handling capabilities, and the type of installation.

NOTE: In the following paragraphs, we will mention LOSSES several times. We will discuss these losses more thoroughly under "LOSSES IN TRANSMISSION LINES."

Two-Wire Open Line

One type of parallel line is the TWO-WIRE OPEN LINE illustrated in figure 3-2. This line consists of two wires that are generally spaced from 2 to 6 inches apart by insulating spacers. This type of line is most often used for power lines, rural telephone lines, and telegraph lines. It is sometimes used as a transmission line between a transmitter and an antenna or between an antenna and a receiver. An advantage of this type of line is its simple construction. The principal disadvantages of this type of line are the high radiation losses and electrical noise pickup because of the lack of shielding. Radiation losses are produced by the changing fields created by the changing current in each conductor.

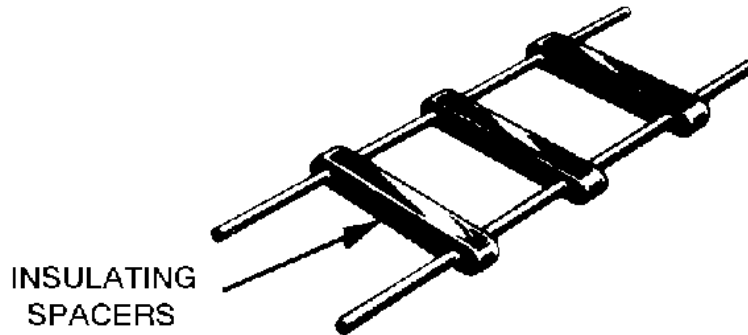

Figure 3-2.—Parallel two-wire line.

Another type of parallel line is the TWO-WIRE RIBBON (TWIN LEAD) illustrated in figure 3-3. This type of transmission line is commonly used to connect a television receiving antenna to a home television set. This line is essentially the same as the two-wire open line except that uniform spacing is assured by embedding the two wires in a low-loss dielectric, usually polyethylene. Since the wires are embedded in the thin ribbon of polyethylene, the dielectric space is partly air and partly polyethylene.

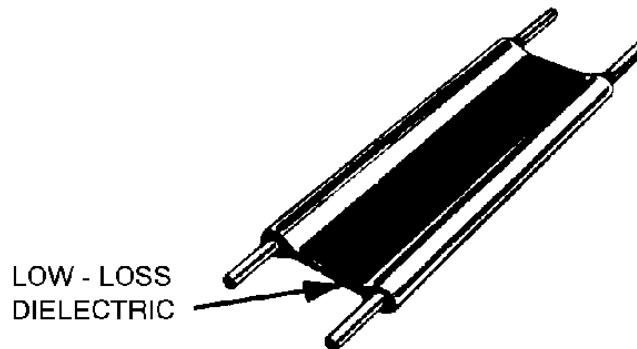

Figure 3-3.—Two-wire ribbon type line.

Twisted Pair

The TWISTED PAIR transmission line is illustrated in figure 3-4. As the name implies, the line consists of two insulated wires twisted together to form a flexible line without the use of spacers. It is not used for transmitting high frequency because of the high dielectric losses that occur in the rubber insulation. When the line is wet, the losses increase greatly.



Figure 3-4.—Twisted pair.

Shielded Pair

The SHIELDED PAIR, shown in figure 3-5, consists of parallel conductors separated from each other and surrounded by a solid dielectric. The conductors are contained within a braided copper tubing that acts as an electrical shield. The assembly is covered with a rubber or flexible composition coating that protects the line from moisture and mechanical damage. Outwardly, it looks much like the power cord of a washing machine or refrigerator.

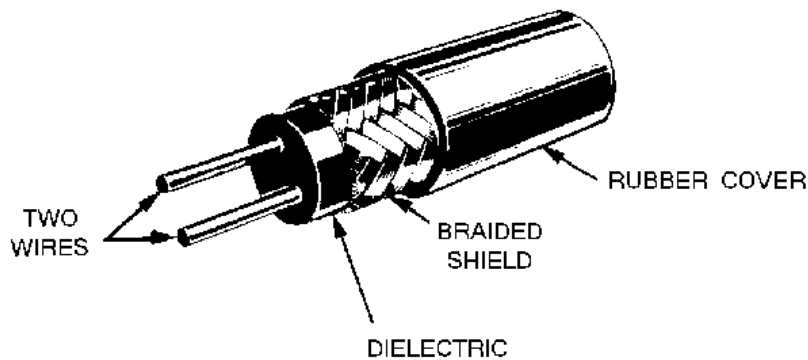

Figure 3-5.—Shielded pair.

The principal advantage of the shielded pair is that the conductors are balanced to ground; that is, the capacitance between the wires is uniform throughout the length of the line. This balance is due to the uniform spacing of the grounded shield that surrounds the wires along their entire length. The braided copper shield isolates the conductors from stray magnetic fields.

Coaxial Lines

There are two types of COAXIAL LINES, RIGID (AIR) COAXIAL LINE and FLEXIBLE (SOLID) COAXIAL LINE. The physical construction of both types is basically the same; that is, each contains two concentric conductors.

The rigid coaxial line consists of a central, insulated wire (inner conductor) mounted inside a tubular outer conductor. This line is shown in figure 3-6. In some applications, the inner conductor is also tubular. The inner conductor is insulated from the outer conductor by insulating spacers or beads at regular intervals. The spacers are made of Pyrex, polystyrene, or some other material that has good insulating characteristics and low dielectric losses at high frequencies.

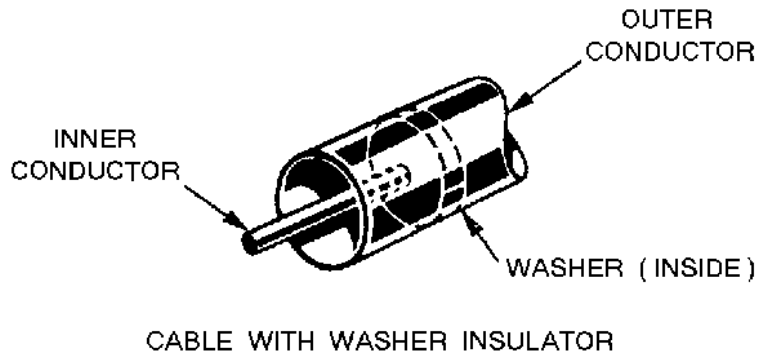

Figure 3-6.—Air coaxial line.

The chief advantage of the rigid line is its ability to minimize radiation losses. The electric and magnetic fields in a two-wire parallel line extend into space for relatively great distances and radiation losses occur. However, in a coaxial line no electric or magnetic fields extend outside of the outer conductor. The fields are confined to the space between the two conductors, resulting in a perfectly shielded coaxial line. Another advantage is that interference from other lines is reduced.

The rigid line has the following disadvantages: (1) it is expensive to construct; (2) it must be kept dry to prevent excessive leakage between the two conductors; and (3) although high-frequency losses are somewhat less than in previously mentioned lines, they are still excessive enough to limit the practical length of the line.

Leakage caused by the condensation of moisture is prevented in some rigid line applications by the use of an inert gas, such as nitrogen, helium, or argon. It is pumped into the dielectric space of the line at a pressure that can vary from 3 to 35 pounds per square inch. The inert gas is used to dry the line when it is first installed and pressure is maintained to ensure that no moisture enters the line.

Flexible coaxial lines (figure 3-7) are made with an inner conductor that consists of flexible wire insulated from the outer conductor by a solid, continuous insulating material. The outer conductor is made of metal braid, which gives the line flexibility. Early attempts at gaining flexibility involved using rubber insulators between the two conductors. However, the rubber insulators caused excessive losses at high frequencies.

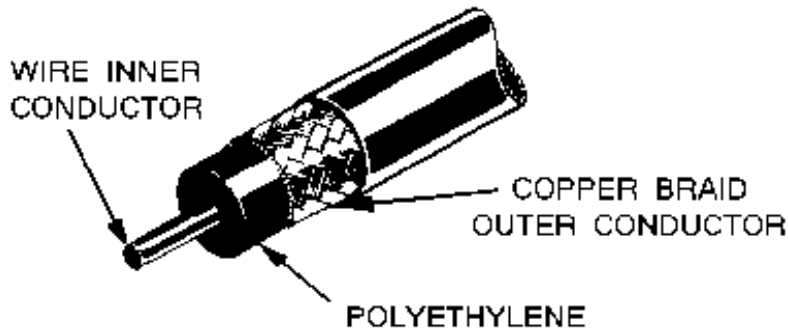

Figure 3-7.—Flexible coaxial line.

Because of the high-frequency losses associated with rubber insulators, polyethylene plastic was developed to replace rubber and eliminate these losses. Polyethylene plastic is a solid substance that remains flexible over a wide range of temperatures. It is unaffected by seawater, gasoline, oil, and most other liquids that may be found aboard ship. The use of polyethylene as an insulator results in greater high-frequency losses than the use of air as an insulator. However, these losses are still lower than the losses associated with most other solid dielectric materials.

Waveguides

The WAVEGUIDE is classified as a transmission line. However, the method by which it transmits energy down its length differs from the conventional methods. Waveguides are cylindrical, elliptical, or rectangular (cylindrical and rectangular shapes are shown in figure 3-8). The rectangular waveguide is used more frequently than the cylindrical waveguide.

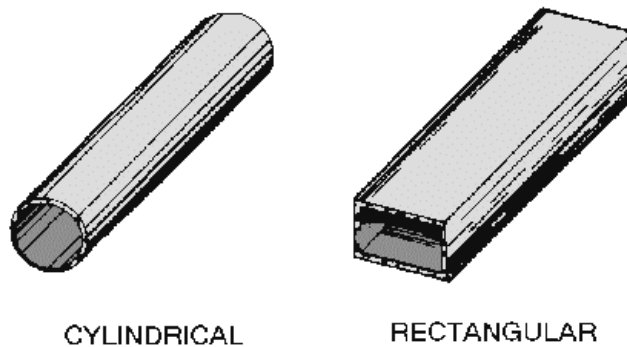

Figure 3-8.—Waveguides.

The term *waveguide* can be applied to all types of transmission lines in the sense that they are all used to guide energy from one point to another. However, usage has generally limited the term to mean a hollow metal tube or a dielectric transmission line. In this chapter, we use the term *waveguide* only to mean "hollow metal tube." It is interesting to note that the transmission of electromagnetic energy along a waveguide travels at a velocity somewhat slower than electromagnetic energy traveling through free space.

A waveguide may be classified according to its cross section (rectangular, elliptical, or circular), or according to the material used in its construction (metallic or dielectric). Dielectric waveguides are

seldom used because the dielectric losses for all known dielectric materials are too great to transfer the electric and magnetic fields efficiently.

The installation of a complete waveguide transmission system is somewhat more difficult than the installation of other types of transmission lines. The radius of bends in the waveguide must measure greater than two wavelengths at the operating frequency of the equipment to avoid excessive attenuation. The cross section must remain uniform around the bend. These requirements hamper installation in confined spaces. If the waveguide is dented, or if solder is permitted to run inside the joints, the attenuation of the line is greatly increased. Dents and obstructions in the waveguide also reduce its breakdown voltage, thus limiting the waveguide's power-handling capability because of possible arc over. Great care must be exercised during installation; one or two carelessly made joints can seriously inhibit the advantage of using the waveguide.

We will not consider the waveguide operation in this module, since waveguide theory is discussed in *NEETS*, Module 11, *Microwave Principles*.

Q4. List the five types of transmission lines in use today.

Q5. Name two of the three described uses of a two-wire open line.

Q6. What are the two primary disadvantages of a two-wire open line?

Q7. What type of transmission line is often used to connect a television set to its antenna?

Q8. What is the primary advantage of the shielded pair?

Q9. What are the two types of coaxial lines in use today?

Q10. What is the chief advantage of the air coaxial line?

Q11. List the three disadvantages of the air coaxial line.

Q12. List the two common types of waveguides in use today.

LOSSES IN TRANSMISSION LINES

The discussion of transmission lines so far has not directly addressed **LINE LOSSES**; actually some line losses occur in all lines. Line losses may be any of three types—**COPPER**, **DIELECTRIC**, and **RADIATION** or **INDUCTION LOSSES**.

NOTE: Transmission lines are sometimes referred to as rf lines. In this text the terms are used interchangeably.

Copper Losses

One type of copper loss is **I²R LOSS**. In rf lines the resistance of the conductors is never equal to zero. Whenever current flows through one of these conductors, some energy is dissipated in the form of heat. This heat loss is a **POWER LOSS**. With copper braid, which has a resistance higher than solid tubing, this power loss is higher.

Another type of copper loss is due to **SKIN EFFECT**. When dc flows through a conductor, the movement of electrons through the conductor's cross section is uniform. The situation is somewhat different when ac is applied. The expanding and collapsing fields about each electron encircle other electrons. This phenomenon, called **SELF INDUCTION**, retards the movement of the encircled electrons.

The flux density at the center is so great that electron movement at this point is reduced. As frequency is increased, the opposition to the flow of current in the center of the wire increases. Current in the center of the wire becomes smaller and most of the electron flow is on the wire surface. When the frequency applied is 100 megahertz or higher, the electron movement in the center is so small that the center of the wire could be removed without any noticeable effect on current. You should be able to see that the effective cross-sectional area decreases as the frequency increases. Since resistance is inversely proportional to the cross-sectional area, the resistance will increase as the frequency is increased. Also, since power loss increases as resistance increases, power losses increase with an increase in frequency because of skin effect.

Copper losses can be minimized and conductivity increased in an rf line by plating the line with silver. Since silver is a better conductor than copper, most of the current will flow through the silver layer. The tubing then serves primarily as a mechanical support.

Dielectric Losses

DIELECTRIC LOSSES result from the heating effect on the dielectric material between the conductors. Power from the source is used in heating the dielectric. The heat produced is dissipated into the surrounding medium. When there is no potential difference between two conductors, the atoms in the dielectric material between them are normal and the orbits of the electrons are circular. When there is a potential difference between two conductors, the orbits of the electrons change. The excessive negative charge on one conductor repels electrons on the dielectric toward the positive conductor and thus distorts the orbits of the electrons. A change in the path of electrons requires more energy, introducing a power loss.

The atomic structure of rubber is more difficult to distort than the structure of some other dielectric materials. The atoms of materials, such as polyethylene, distort easily. Therefore, polyethylene is often used as a dielectric because less power is consumed when its electron orbits are distorted.

Radiation and Induction Losses

RADIATION and INDUCTION LOSSES are similar in that both are caused by the fields surrounding the conductors. Induction losses occur when the electromagnetic field about a conductor cuts through any nearby metallic object and a current is induced in that object. As a result, power is dissipated in the object and is lost.

Radiation losses occur because some magnetic lines of force about a conductor do not return to the conductor when the cycle alternates. These lines of force are projected into space as radiation and this results in power losses. That is, power is supplied by the source, but is not available to the load.

Q13. What are the three types of line losses associated with transmission lines?

Q14. Losses caused by skin effect and the I^2R (power) loss are classified as what type of loss?

Q15. What types of losses cause the dielectric material between the conductors to be heated?

LENGTH OF A TRANSMISSION LINE

A transmission line is considered to be electrically short when its physical length is short compared to a quarter-wavelength ($1/4\lambda$) of the energy it is to carry.

NOTE: In this module, for ease of reading, the value of the wavelength will be spelled out in some cases, and in other cases, the numerical value will be used.

A transmission line is electrically long when its physical length is long compared to a quarter-wavelength of the energy it is to carry. You must understand that the terms "short" and "long" are relative ones. For example, a line that has a physical length of 3 meters (approximately 10 feet) is considered quite short electrically if it transmits a radio frequency of 30 kilohertz. On the other hand, the same transmission line is considered electrically long if it transmits a frequency of 30,000 megahertz.

To show the difference in physical and electrical lengths of the lines mentioned above, compute the wavelength of the two frequencies, taking the 30-kilohertz example first:

Given:

$$\lambda = \frac{v}{f}$$

Where:

λ = Wavelength

v = Velocity of rf in free space

f = Frequency of transmission

Hz = Cycles per second

$$\lambda = \frac{300 \times 10^6 \text{ meters /second}}{30 \times 10^3 \text{ cycles /second (Hz)}}$$

$$\lambda = 10 \times 10^3 \text{ meters/cycle}$$

$\lambda = 10,000$ meters, or approximately
6 miles for complete wavelength

Now, computing the wavelength for the line carrying 30,000 megahertz:

$$\lambda = \frac{v}{f}$$

$$\lambda = \frac{300 \times 10^6 \text{ meters /second}}{30,000 \times 10^6 \text{ cycles /second (Hz)}}$$

$$\lambda = \frac{1}{100} \text{ meter / cycle}$$

$\lambda = .01$ meter, or approximately .03 foot
for a complete wavelength

Thus, you can see that a 3-meter line is electrically very short for a frequency of 30 kilohertz. Also, the 3-meter line is electrically very long for a frequency of 30,000 megahertz.

When power is applied to a very short transmission line, practically all of it reaches the load at the output end of the line. This very short transmission line is usually considered to have practically no electrical properties of its own, except for a small amount of resistance.

However, the picture changes considerably when a long line is used. Since most transmission lines are electrically long (because of the distance from transmitter to antenna), the properties of such lines must be considered. Frequently, the voltage necessary to drive a current through a long line is considerably greater than the amount that can be accounted for by the impedance of the load in series with the resistance of the line.

TRANSMISSION LINE THEORY

The electrical characteristics of a two-wire transmission line depend primarily on the construction of the line. The two-wire line acts like a long capacitor. The change of its capacitive reactance is noticeable as the frequency applied to it is changed. Since the long conductors have a magnetic field about them when electrical energy is being passed through them, they also exhibit the properties of inductance. The values of inductance and capacitance presented depend on the various physical factors that we discussed earlier. For example, the type of line used, the dielectric in the line, and the length of the line must be considered. The effects of the inductive and capacitive reactances of the line depend on the frequency applied. Since no dielectric is perfect, electrons manage to move from one conductor to the other through the dielectric. Each type of two-wire transmission line also has a conductance value. This conductance value represents the value of the current flow that may be expected through the insulation. If the line is uniform (all values equal at each unit length), then one small section of the line may represent several feet. This illustration of a two-wire transmission line will be used throughout the discussion of transmission lines; but, keep in mind that the principles presented apply to all transmission lines. We will explain the theories using LUMPED CONSTANTS and DISTRIBUTED CONSTANTS to further simplify these principles.

LUMPED CONSTANTS

A transmission line has the properties of inductance, capacitance, and resistance just as the more conventional circuits have. Usually, however, the constants in conventional circuits are lumped into a single device or component. For example, a coil of wire has the property of inductance. When a certain amount of inductance is needed in a circuit, a coil of the proper dimensions is inserted. The inductance of the circuit is lumped into the one component. Two metal plates separated by a small space, can be used to supply the required capacitance for a circuit. In such a case, most of the capacitance of the circuit is lumped into this one component. Similarly, a fixed resistor can be used to supply a certain value of circuit resistance as a lumped sum. Ideally, a transmission line would also have its constants of inductance, capacitance, and resistance lumped together, as shown in figure 3-9. Unfortunately, this is not the case. Transmission line constants are *distributed*, as described below.

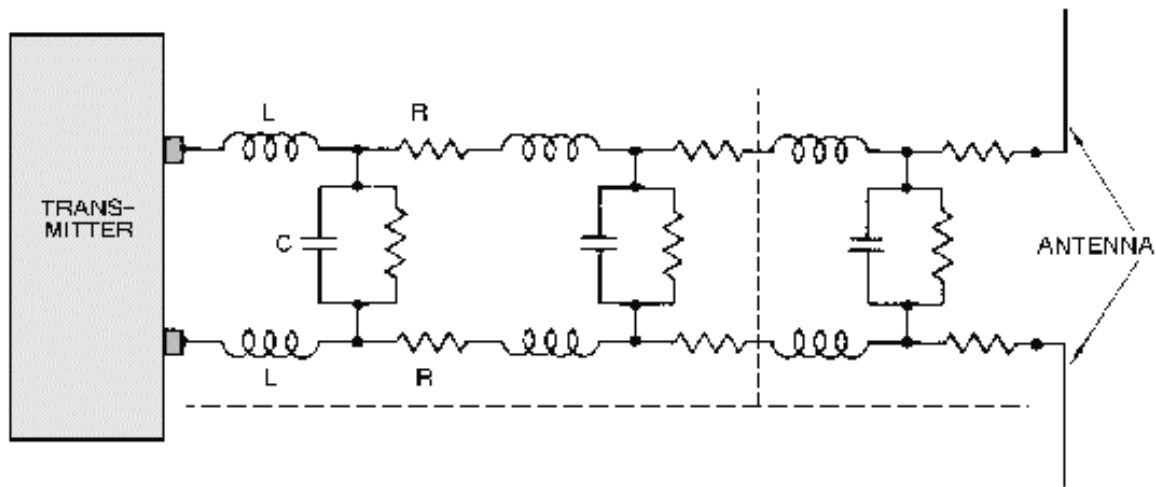

Figure 3-9.—Equivalent circuit of a two-wire transmission line.

DISTRIBUTED CONSTANTS

Transmission line constants, called *distributed constants*, are spread along the entire length of the transmission line and cannot be distinguished separately. The amount of inductance, capacitance, and resistance depends on the length of the line, the size of the conducting wires, the spacing between the wires, and the dielectric (air or insulating medium) between the wires. The following paragraphs will be useful to you as you study distributed constants on a transmission line.

Inductance of a Transmission Line

When current flows through a wire, magnetic lines of force are set up around the wire. As the current increases and decreases in amplitude, the field around the wire expands and collapses accordingly. The energy produced by the magnetic lines of force collapsing back into the wire tends to keep the current flowing in the same direction. This represents a certain amount of inductance, which is expressed in *microhenrys per unit length*. Figure 3-10 illustrates the inductance and magnetic fields of a transmission line.

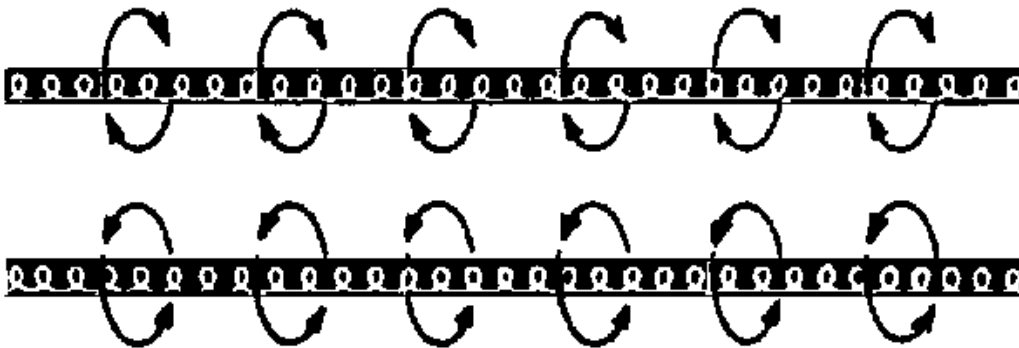

Figure 3-10.—Distributed inductance

Capacitance of a Transmission Line

Capacitance also exists between the transmission line wires, as illustrated in figure 3-11. Notice that the two parallel wires act as plates of a capacitor and that the air between them acts as a dielectric. The capacitance between the wires is usually expressed in *picofarads per unit length*. This electric field between the wires is similar to the field that exists between the two plates of a capacitor.



Figure 3-11.—Distributed capacitance.

Resistance of a Transmission Line

The transmission line shown in figure 3-12 has electrical resistance along its length. This resistance is usually expressed in *ohms per unit length* and is shown as existing continuously from one end of the line to the other.



Figure 3-12.—Distributed resistance.

- Q16. What must the physical length of a transmission line be if it will be operated at 15,000,000 Hz? Use the formula:

$$\lambda = \frac{v}{f}$$

- Q17. What are two of the three physical factors that determine the values of capacitance and inductance of a transmission line?
- Q18. A transmission line is said to have distributed constants of inductance, capacitance, and resistance along the line. What units of measurement are used to express these constants?

Leakage Current

Since any dielectric, even air, is not a perfect insulator, a small current known as LEAKAGE CURRENT flows between the two wires. In effect, the insulator acts as a resistor, permitting current to pass between the two wires. Figure 3-13 shows this leakage path as resistors in parallel connected between the two lines. This property is called CONDUCTANCE (G) and is the opposite of resistance.

Conductance in transmission lines is expressed as the reciprocal of resistance and is usually given in *micromhos per unit length*.

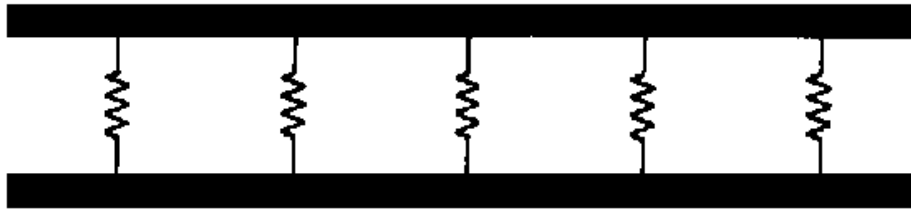

Figure 3-13.—Leakage in a transmission line.

ELECTROMAGNETIC FIELDS ABOUT A TRANSMISSION LINE

The distributed constants of resistance, inductance, and capacitance are basic properties common to all transmission lines and exist whether or not any current flow exists. As soon as current flow and voltage exist in a transmission line, another property becomes quite evident. This is the presence of an electromagnetic field, or lines of force, about the wires of the transmission line. The lines of force themselves are not visible; however, understanding the force that an electron experiences while in the field of these lines is very important to your understanding of energy transmission.

There are two kinds of fields; one is associated with voltage and the other with current. The field associated with voltage is called the ELECTRIC (E) FIELD. It exerts a force on any electric charge placed in it. The field associated with current is called a MAGNETIC (H) FIELD, because it tends to exert a force on any magnetic pole placed in it. Figure 3-14 illustrates the way in which the E fields and H fields tend to orient themselves between conductors of a typical two-wire transmission line. The illustration shows a cross section of the transmission lines. The E field is represented by solid lines and the H field by dotted lines. The arrows indicate the direction of the lines of force. Both fields normally exist together and are spoken of collectively as the electromagnetic field.

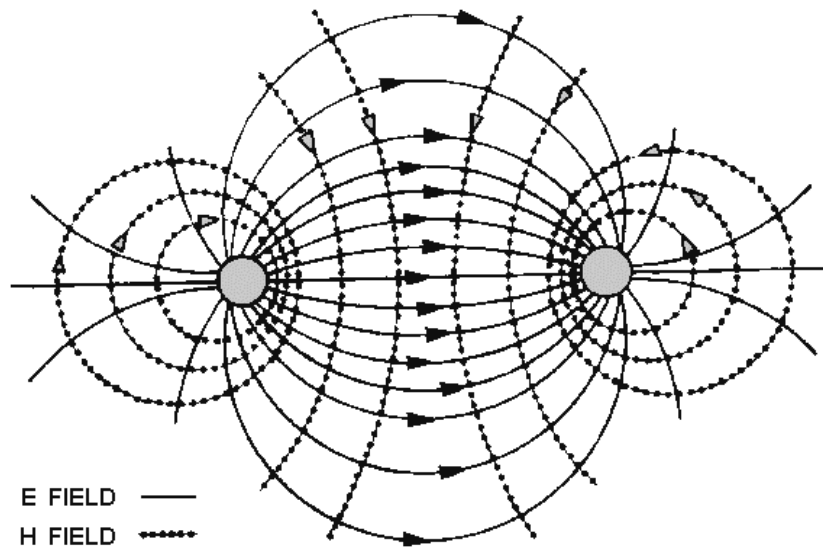

Figure 3-14.—Fields between conductors.

CHARACTERISTIC IMPEDANCE OF A TRANSMISSION LINE

You learned earlier that the maximum (and most efficient) transfer of electrical energy takes place when the source impedance is matched to the load impedance. This fact is very important in the study of transmission lines and antennas. If the characteristic impedance of the transmission line and the load impedance are equal, energy from the transmitter will travel down the transmission line to the antenna with no power loss caused by reflection.

Definition and Symbols

Every transmission line possesses a certain CHARACTERISTIC IMPEDANCE, usually designated as Z_0 . Z_0 is the ratio of E to I at every point along the line. If a load equal to the characteristic impedance is placed at the output end of any length of line, the same impedance will appear at the input terminals of the line. The characteristic impedance is the only value of impedance for any given type and size of line that acts in this way. The characteristic impedance determines the amount of current that can flow when a given voltage is applied to an infinitely long line. Characteristic impedance is comparable to the resistance that determines the amount of current that flows in a dc circuit.

In a previous discussion, lumped and distributed constants were explained. Figure 3-15, view A, shows the properties of resistance, inductance, capacitance, and conductance combined in a short section of two-wire transmission line. The illustration shows the evenly distributed capacitance as a single lumped capacitor and the distributed conductance as a lumped leakage path. Lumped values may be used for transmission line calculations if the physical length of the line is very short compared to the wavelength of energy being transmitted. Figure 3-15, view B, shows all four properties lumped together and represented by their conventional symbols.

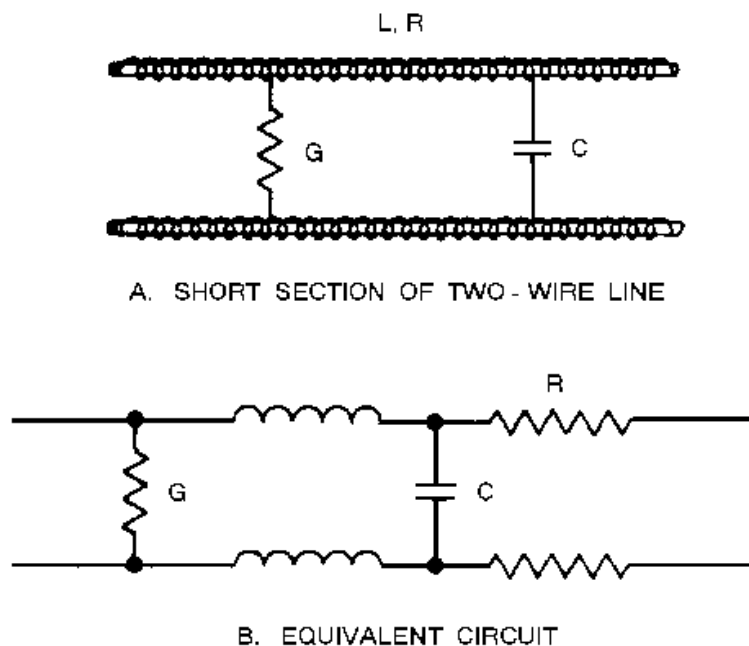

Figure 3-15.—Short section of two-wire transmission line and equivalent circuit.

Q19. Describe the leakage current in a transmission line and in what unit it is expressed.

Q20. All the power sent down a transmission line from a transmitter can be transferred to an antenna under what optimum conditions?

Q21. What symbol is used to designate the characteristic impedance of a line, and what two variables does it compare?

Characteristic Impedance and the Infinite Line

Several short sections, as shown in figure 3-15, can be combined to form a large transmission line, as shown in figure 3-16. Current will flow if voltage is applied across points K and L. In fact, any circuit, such as that represented in figure 3-16, view A, has a certain current flow for each value of applied voltage. The ratio of the voltage to the current is the impedance (Z).

Recall that:

$$Z = \frac{E}{I}$$

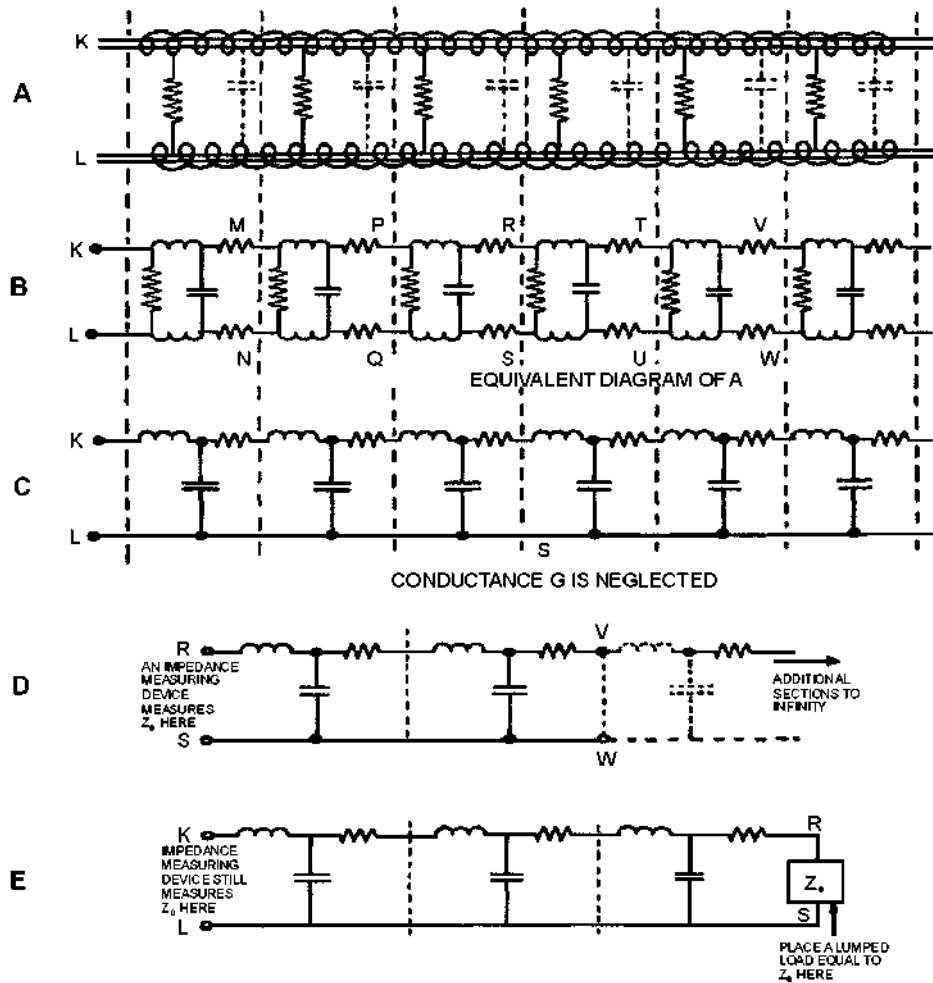

Figure 3-16.—Characteristic impedance.

The impedance presented to the input terminals of the transmission line is not merely the resistance of the wire in series with the impedance of the load. The effects of series inductance and shunt capacitance of the line itself may overshadow the resistance, and even the load, as far as the input terminals are concerned.

To find the input impedance of a transmission line, determine the impedance of a single section of line. The impedance between points K and L, in view B of figure 3-16, can be calculated by the use of series-parallel impedance formulas, provided the impedance across points M and N is known. But since this section is merely one small part of a longer line, another similar section is connected to points M and N. Again, the impedance across points K and L of the two sections can be calculated, provided the impedance of the third section is known. This process of adding one section to another can be repeated endlessly. The addition of each section produces an impedance across points K and L of a new and lower value. However, after many sections have been added, each successive added section has less and less effect on the impedance across points K and L. If sections are added to the line endlessly, the line is infinitely long, and a certain finite value of impedance across points K and L is finally reached.

In this discussion of transmission lines, the effect of conductance (G) is minor compared to that of inductance (L) and capacitance (C), and is frequently neglected. In figure 3-16, view C, G is omitted and the inductance and resistance of each line can be considered as one line.

Let us assume that the sections of view C continue to the right with an infinite number of sections. When an infinite number of sections extends to the right, the impedance appearing across K and L is Z_0 . If the line is cut at R and S, an infinite number of sections still extends to the right since the line is endless in that direction. Therefore, the impedance now appearing across points R and S is also Z_0 , as illustrated in view D. You can see that if only the first three sections are taken and a load impedance of Z_0 is connected across points R and S, the impedance across the input terminals K and L is still Z_0 . The line continues to act as an infinite line. This is illustrated in view E.

Figure 3-17, view A, illustrates how the characteristic impedance of an infinite line can be calculated. Resistors are added in series parallel across terminals K and L in eight steps, and the resultant impedances are noted. In step 1 the impedance is infinite; in step 2 the impedance is 110 ohms. In step 3 the impedance becomes 62.1 ohms, a change of 47.9 ohms. In step 4 the impedance is 48.5 ohms, a change of only 13.6 ohms. The resultant changes in impedance from each additional increment become progressively smaller. Eventually, practically no change in impedance results from further additions to the line. The total impedance of the line at this point is said to be at its characteristic impedance; which, in this case, is 37 ohms. This means that an infinite line constructed as indicated in step 8 could be effectively replaced by a 37-ohm resistor. View B shows a 37-ohm resistor placed in the line at various points to replace the infinite line of step 8 in view A. There is no change in total impedance.

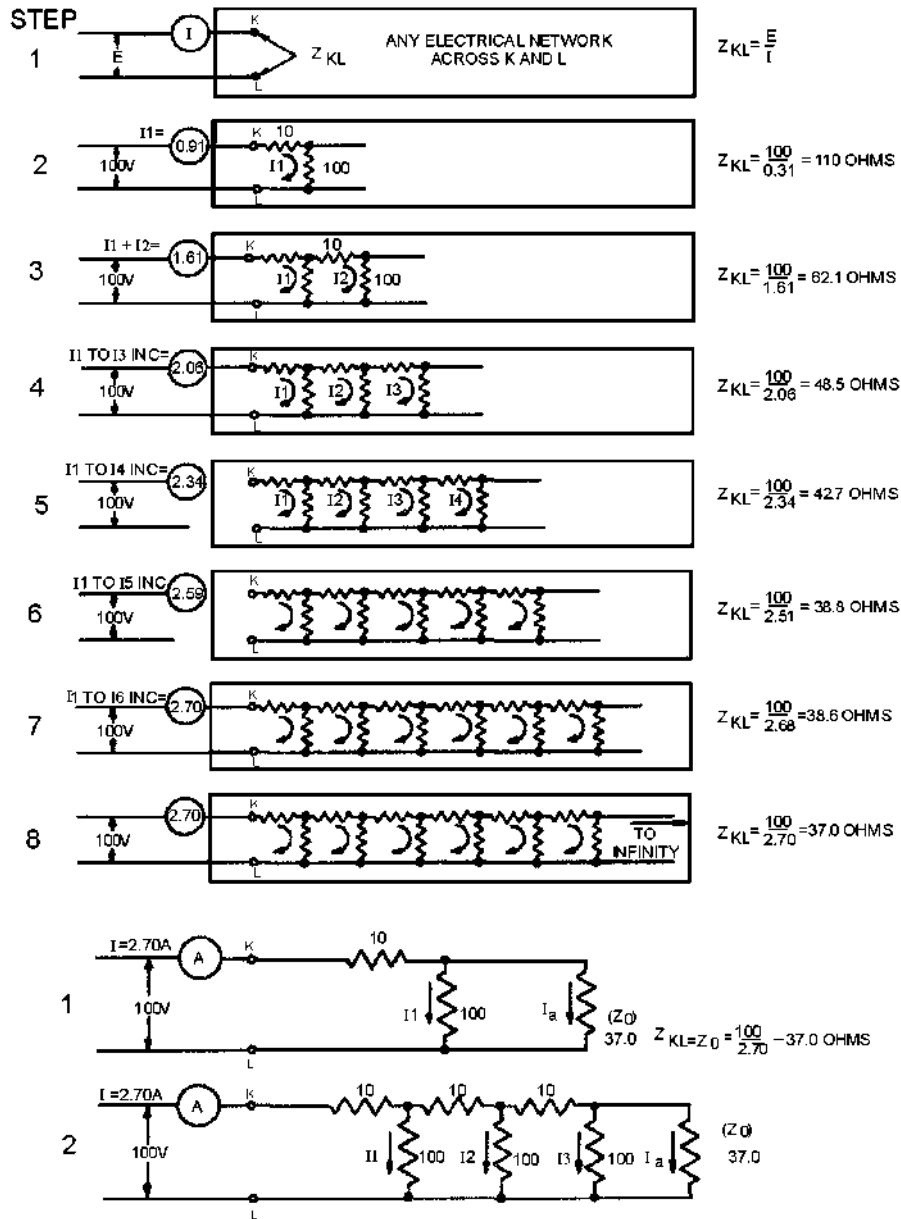

Figure 3-17.—Termination of a line.

In figure 3-17, resistors were used to show impedance characteristics for the sake of simplicity. Figuring the actual impedance of a line having reactance is very similar, with inductance taking the place of the series resistors and capacitance taking the place of the shunt resistors. The characteristic impedance of lines in actual use normally lies between 50 and 600 ohms.

When a transmission line is "short" compared to the length of the radio-frequency waves it carries, the opposition presented to the input terminals is determined primarily by the load impedance. A small amount of power is dissipated in overcoming the resistance of the line. However, when the line is "long" and the load is an incorrect impedance, the voltages necessary to drive a given amount of current through the line cannot be accounted for by considering just the impedance of the load in series with the

impedance of the line. The line has properties other than resistance that affect input impedance. These properties are inductance in series with the line, capacitance across the line, resistance leakage paths across the line, and certain radiation losses.

Q22. What is the range of the characteristic impedance of lines used in actual practice?

VOLTAGE CHANGE ALONG A TRANSMISSION LINE

Let us summarize what we have just discussed. In an electric circuit, energy is stored in electric and magnetic fields. These fields must be brought to the load to transmit that energy. At the load, energy contained in the fields is converted to the desired form of energy.

Transmission of Energy

When the load is connected directly to the source of energy, or when the transmission line is short, problems concerning current and voltage can be solved by applying Ohm's law. When the transmission line becomes long enough so the time difference between a change occurring at the generator and the change appearing at the load becomes appreciable, analysis of the transmission line becomes important.

Dc Applied to a Transmission Line

In figure 3-18, a battery is connected through a relatively long two-wire transmission line to a load at the far end of the line. At the instant the switch is closed, neither current nor voltage exists on the line. When the switch is closed, point A becomes a positive potential, and point B becomes negative. These points of difference in potential move down the line. However, as the initial points of potential leave points A and B, they are followed by new points of difference in potential which the battery adds at A and B. This is merely saying that the battery maintains a constant potential difference between points A and B. A short time after the switch is closed, the initial points of difference in potential have reached points A' and B'; the wire sections from points A to A' and points B to B' are at the same potential as A and B, respectively. The points of charge are represented by plus (+) and minus (-) signs along the wires. The directions of the currents in the wires are represented by the arrowheads on the line, and the direction of travel is indicated by an arrow below the line. Conventional lines of force represent the electric field that exists between the opposite kinds of charge on the wire sections from A to A' and B to B'. Crosses (tails of arrows) indicate the magnetic field created by the electric field moving down the line. The moving electric field and the accompanying magnetic field constitute an electromagnetic wave that is moving from the generator (battery) toward the load. This wave travels at approximately the speed of light in free space. The energy reaching the load is equal to that developed at the battery (assuming there are no losses in the transmission line). If the load absorbs all of the energy, the current and voltage will be evenly distributed along the line.

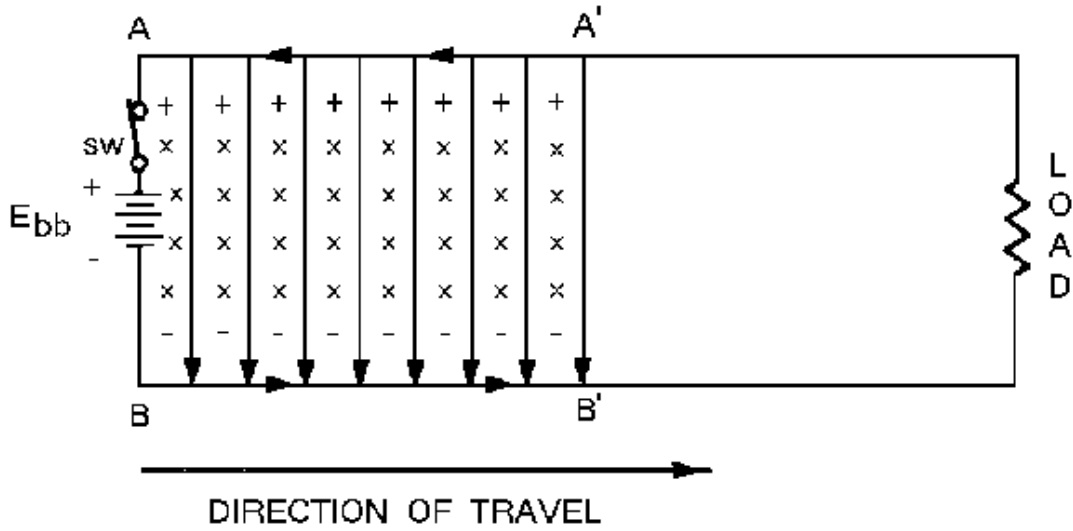

Figure 3-18.—Dc voltage applied to a line.

Ac Applied to a Transmission Line

When the battery of figure 3-18 is replaced by an ac generator (fig. 3-19), each successive instantaneous value of the generator voltage is propagated down the line at the speed of light. The action is similar to the wave created by the battery except that the applied voltage is sinusoidal instead of constant. Assume that the switch is closed at the moment the generator voltage is passing through zero and that the next half cycle makes point A positive. At the end of one cycle of generator voltage, the current and voltage distribution will be as shown in figure 3-19.

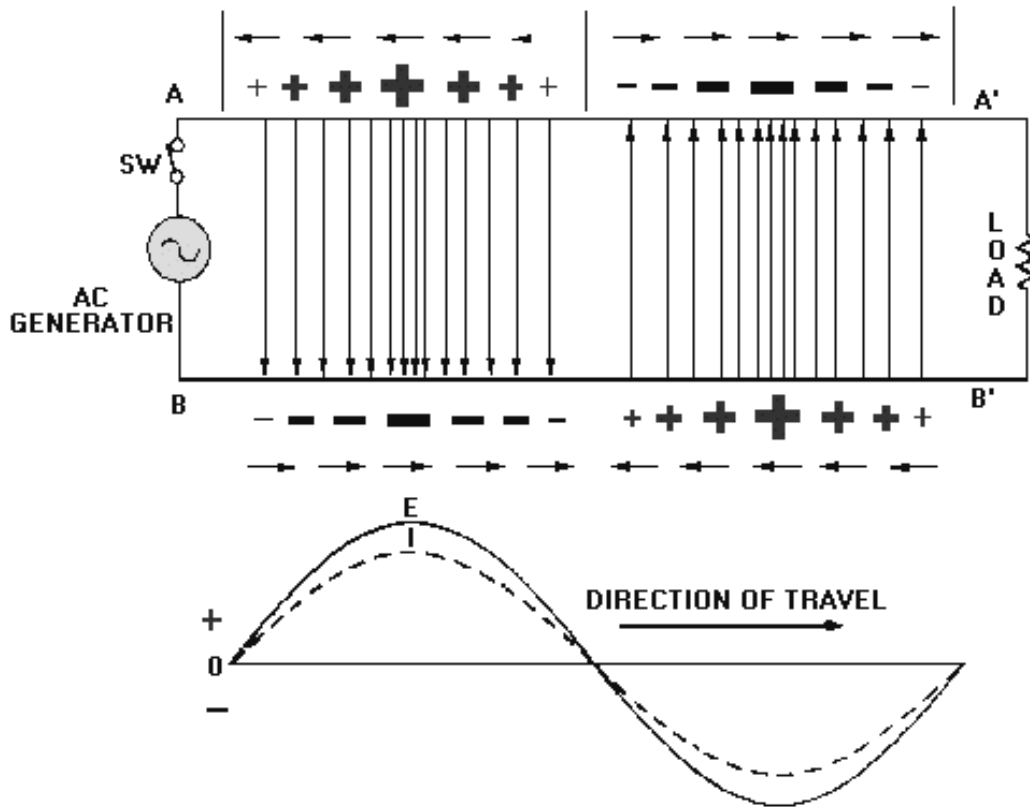

Figure 3-19.—Ac voltage applied to a line.

In this illustration the conventional lines of force represent the electric fields. For simplicity, the magnetic fields are not shown. Points of charge are indicated by plus (+) and minus (-) signs, the larger signs indicating points of higher amplitude of both voltage and current. Short arrows indicate direction of current (electron flow). The waveform drawn below the transmission line represents the voltage (E) and current (I) waves. The line is assumed to be infinite in length so there is no reflection. Thus, traveling sinusoidal voltage and current waves continually travel in phase from the generator toward the load, or far end of the line. Waves traveling from the generator to the load are called INCIDENT WAVES. Waves traveling from the load back to the generator are called REFLECTED WAVES and will be explained in later paragraphs.

Dc Applied to an Infinite Line

Figure 3-20 shows a battery connected to a circuit that is the equivalent of a transmission line. In this line the series resistance and shunt conductance are not shown. In the following discussion the line will be considered to have no losses.

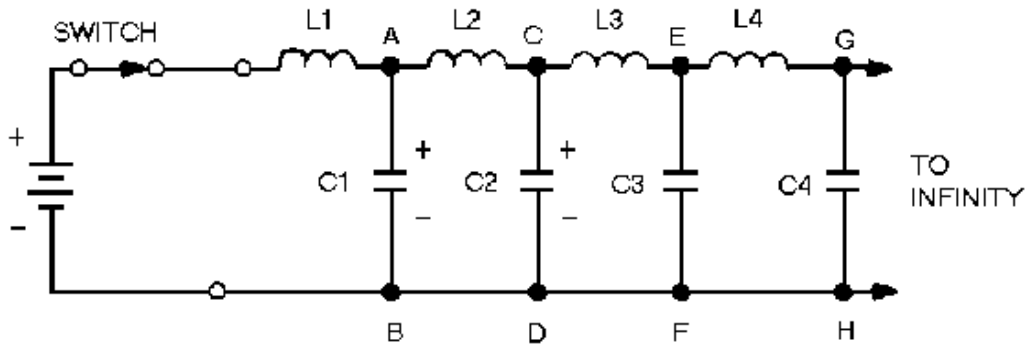

Figure 3-20.—Dc applied to an equivalent transmission line.

As the switch is closed, the battery voltage is applied to the input terminals of the line. Now, C1 has no charge and appears, effectively, as a short circuit across points A and B. The full battery voltage appears across inductor L1. Inductor L1 opposes the change of current (0 now) and limits the rate of charge of C1.

Capacitor C2 cannot begin to charge until after C1 has charged. No current can flow beyond points A and B until C1 has acquired some charge. As the voltage across C1 increases, current through L2 and C2 charges C2. This action continues down the line and charges each capacitor, in turn, to the battery voltage. Thus a voltage wave is traveling along the line. Beyond the wavefront, the line is uncharged. Since the line is infinitely long, there will always be more capacitors to be charged, and current will not stop flowing. Thus current will flow indefinitely in the line.

Notice that current flows to charge the capacitors along the line. The flow of current is not advanced along the line until a voltage is developed across each preceding capacitor. In this manner voltage and current move down the line together in phase.

Ac Applied to an Infinite Line

An rf line displays similar characteristics when an ac voltage is applied to its sending end or input terminals. In figure 3-21, view A, an ac voltage is applied to the line represented by the circuit shown.

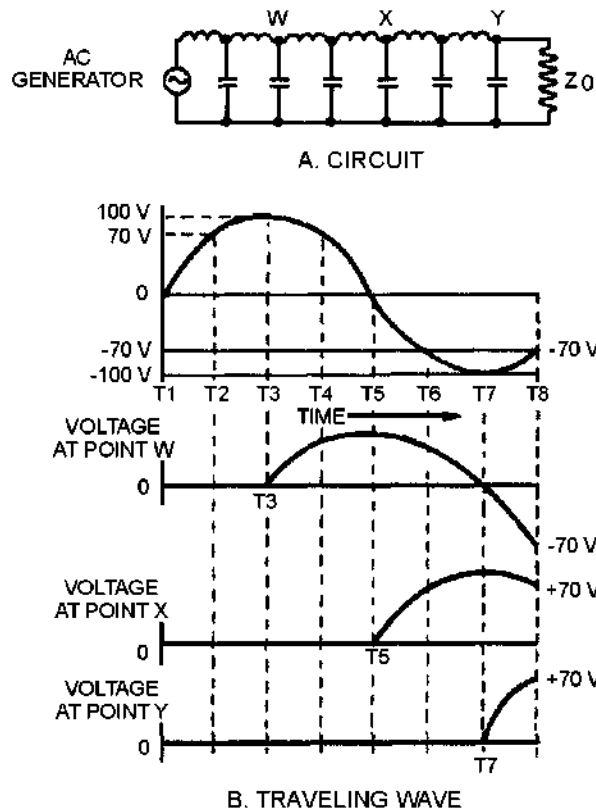

Figure 3-21.—Ac applied to an equivalent transmission line.

In view B the generator voltage starts from zero (T1) and produces the voltage shown. As soon as a small voltage change is produced, it starts its journey down the line while the generator continues to produce new voltages along a sine curve. At T2 the generator voltage is 70 volts. The voltages still move along the line until, at T3, the first small change arrives at point W, and the voltage at that point starts increasing. At T5, the same voltage arrives at point X on the line. Finally, at T7, the first small change arrives at the receiving end of the line. Meanwhile, all the changes in the sine wave produced by the generator pass each point in turn. The amount of time required for the changes to travel the length of the line is the same as that required for a dc voltage to travel the same distance.

At T7, the voltage at the various points on the line is as follows:

| | |
|-------------------|--------|
| At the generator: | -100 V |
| At point W: | 0 V |
| At point X: | +100 V |
| At point Y: | 0 V |

If these voltages are plotted along the length of the line, the resulting curve is like the one shown in figure 3-22, view A. Note that such a curve of instantaneous voltages resembles a sine wave. The changes in voltage that occur between T7 and T8 are as follows:

| | | |
|-------------------|-----------|-----------------|
| At the generator: | Rise from | -100 V to -70 V |
| At point W: | Drop from | 0 V to -70 V |
| At point X: | Drop from | +100 V to +70 V |
| At point Y: | Rise from | 0 V to +70 V |

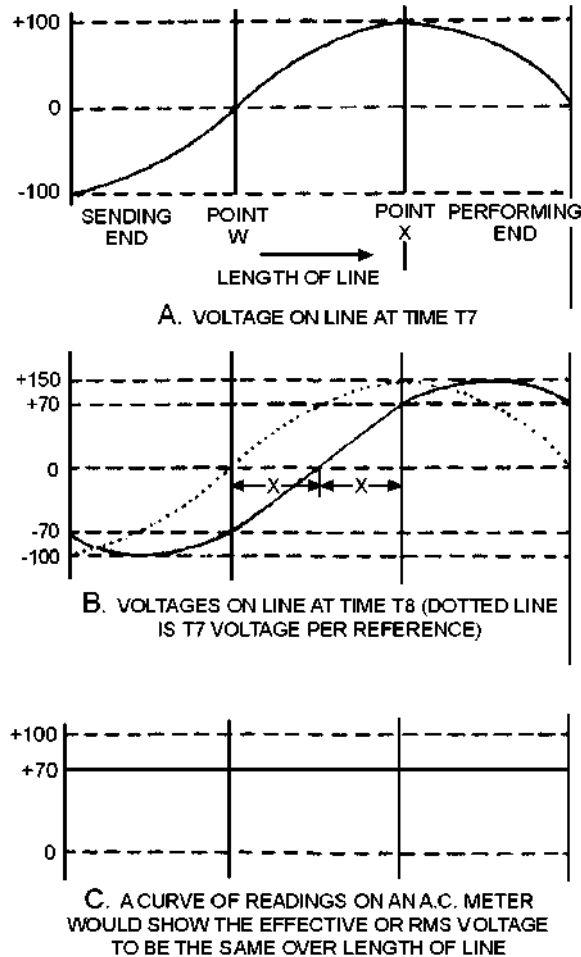

Figure 3-22.—Instantaneous voltages along a transmission line.

A plot of these new voltages produces the solid curve shown in figure 3-22, view B. For reference, the curve from T7 is drawn as a dotted line. The solid curve has exactly the same shape as the dotted curve, but has moved to the right by the distance X. Another plot at T9 would show a new curve similar to the one at T8, but moved to the right by the distance Y.

By analyzing the points along the graph just discussed, you should be able to see that the actions associated with voltage changes along an rf line are as follows:

1. All instantaneous voltages of the sine wave produced by the generator travel down the line in the order they are produced.
2. At any point, a sine wave can be obtained if all the instantaneous voltages passing the point are plotted. An oscilloscope can be used to plot these values of instantaneous voltages against time.

3. The instantaneous voltages (oscilloscope displays) are the same in all cases except that a phase difference exists in the displays seen at different points along the line. The phase changes continually with respect to the generator until the change is 360 degrees over a certain length of line.
4. All parts of a sine wave pass every point along the line. A plot of the readings of an ac meter (which reads the effective value of the voltage over a given time) taken at different points along the line shows that the voltage is constant at all points. This is shown in view C of figure 3-22.
5. Since the line is terminated with a resistance equal to Z_0 , the energy arriving at the end of the line is absorbed by the resistance.

VELOCITY OF WAVE PROPAGATION

If a voltage is initially applied to the sending end of a line, that same voltage will appear later some distance from the sending end. This is true regardless of any change in voltage, whether the change is a jump from zero to some value or a drop from some value to zero. The voltage change will be conducted down the line at a constant rate.

Recall that the inductance of a line delays the charging of the line capacitance. The velocity of propagation is therefore related to the values of L and C. If the inductance and capacitance of the rf line are known, the time required for any waveform to travel the length of the line can be determined. To see how this works, observe the following relationship:

$$Q = IT$$

This formula shows that the total charge or quantity is equal to the current multiplied by the time the current flows. Also:

$$Q = CE$$

This formula shows that the total charge on a capacitor is equal to the capacitance multiplied by the voltage across the capacitor.

If the switch in figure 3-23 is closed for a given time, the quantity (Q) of electricity leaving the battery can be computed by using the equation $Q = IT$. The electricity leaves the battery and goes into the line, where a charge is built up on the capacitors. The amount of this charge is computed by using the equation $Q = CE$.

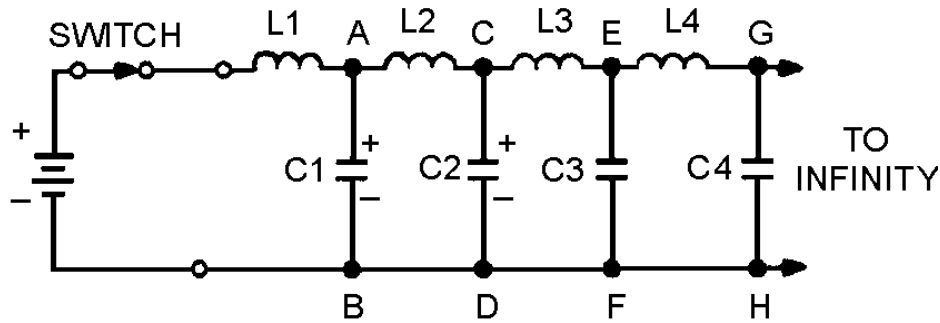

Figure 3-23.—Dc applied to an equivalent transmission line.

Since none of the charge is lost, the total charge leaving the battery during T is equal to the total charge on the line. Therefore:

$$Q = IT = CE$$

As each capacitor accumulates a charge equal to CE, the voltage across each inductor must change. As C1 in figure 3-23 charges to a voltage of E, point A rises to a potential of E volts while point B is still at zero volts. This makes E appear across L2. As C2 charges, point B rises to a potential of E volts as did point A. At this time, point B is at E volts and point C rises. Thus, we have a continuing action of voltage moving down the infinite line.

In an inductor, these circuit components are related, as shown in the formula

$$E = L \left(\frac{\Delta I}{\Delta T} \right).$$

This shows that the voltage across the inductor is directly proportional to inductance and the change in current, but inversely proportional to a change in time. Since current and time start from zero, the change in time (ΔT) and the change in current (ΔI) are equal to the final time (T) and final current (I). For this case the equation becomes:

$$ET = LI$$

If voltage E is applied for time (T) across the inductor (L), the final current (I) will flow. The following equations show how the three terms (T, L, and C) are related:

$$\begin{aligned} IT &= CE \\ ET &= LI \end{aligned}$$

For convenience, you can find T in terms of L and C in the following manner. Multiply the left and right member of each equation as follows:

$$(IT)(ET) = (CE)(LI)$$

Then: $EIT^2 = LCEI$

Dividing by (EI): $T^2 = LC$

and $T = \sqrt{LC}$

This final equation is used for finding the time required for a voltage change to travel a unit length, since L and C are given in terms of unit length. The velocity of the waves may be found by:

$$V = \frac{D}{T} \text{ or } V = \frac{D}{\sqrt{LC}}$$

Where: D is the physical length of a unit

This is the rate at which the wave travels over a unit length. The units of L and C are henrys and farads, respectively. T is in seconds per unit length and V is in unit lengths per second.

DETERMINING CHARACTERISTIC IMPEDANCE

As previously discussed, an infinite transmission line exhibits a definite input impedance. This impedance is the CHARACTERISTIC IMPEDANCE and is independent of line length. The exact value of this impedance is the ratio of the input voltage to the input current. If the line is infinite or is terminated in a resistance equal to the characteristic impedance, voltage and current waves traveling the line are in phase. To determine the characteristic impedance or voltage-to-current ratio, use the following procedure:

Divide the equation:

$$ET = LI \text{ by } IT = CE$$

$$\frac{ET}{IT} = \frac{LI}{CE}$$

Multiply by $\frac{E}{I}$:

$$\frac{E^2 T}{I^2 T} = \frac{LIE}{CEI}$$

Simplify:

$$\frac{E^2}{I^2} = \frac{L}{C}$$

Take the square root:

$$\frac{E}{I} = \sqrt{\frac{L}{C}} = Z_0 \text{ (characteristic impedance)}$$

Example:

A problem using this equation will illustrate how to determine the characteristics of a transmission line. Assume that the line shown in figure 3-23 is 1000 feet long. A 100-foot (approximately 30.5 meter) section is measured to determine L and C. The section is found to have an inductance of 0.25 millihenries and a capacitance of 1000 picofarads. Find the characteristic impedance of the line and the velocity of the wave on the line.

The characteristic impedance is:

$$Z_0 = \sqrt{LC}$$

$$Z_0 = \sqrt{\frac{0.25 \times 10^{-3}}{1000 \times 10^{-12}}}$$

$$Z_0 = \sqrt{0.25 \times 10^6}$$

$$Z_0 = 0.5 \times 10^3$$

$$Z_0 = 500 \Omega$$

If any other unit length had been considered, the values of L and C would be different, but their ratio would remain the same as would the characteristic impedance.

The formula for T is:

$$T = \sqrt{LC}$$

$$T = \sqrt{0.25 \times 10^{-3} \times 1000 \times 10^{-12}}$$

$$T = \sqrt{0.25 \times 10^{-12}}$$

$$T = 0.5 \times 10^{-6} \text{ second}$$

$$T = 0.5 \text{ microsecond}$$

The formula for the velocity of a wave is:

$$V = \frac{D}{T}$$

$$V = \frac{100 \text{ feet}}{0.5 \times 10^{-6} \text{ second}}$$

$$V = 200 \times 10^6 \text{ feet/second}$$

$$V = 200,000,000 \text{ feet/second}$$

REFLECTIONS ON A TRANSMISSION LINE

Transmission line characteristics are based on an infinite line. A line cannot always be terminated in its characteristic impedance since it is sometimes operated as an OPEN-ENDED line and other times as a SHORT-CIRCUIT at the receiving end. If the line is open-ended, it has a terminating impedance that is infinitely large. If a line is not terminated in characteristic impedance, it is said to be finite.

When a line is not terminated in Z_0 , the incident energy is not absorbed but is returned along the only path available—the transmission line. Thus, the behavior of a finite line may be quite different from that of the infinite line.

REFLECTION OF DC VOLTAGE FROM AN OPEN CIRCUIT

The equivalent circuit of an open-ended transmission line is shown in figure 3-24, view A. Again, losses are to be considered as negligible, and L is lumped in one branch. Assume that (1) the battery in this circuit has an internal impedance equal to the characteristic impedance of the transmission line ($Z_i = Z_0$); (2) the capacitors in the line are not charged before the battery is connected; and (3) since the line is open-ended, the terminating impedance is infinitely large.

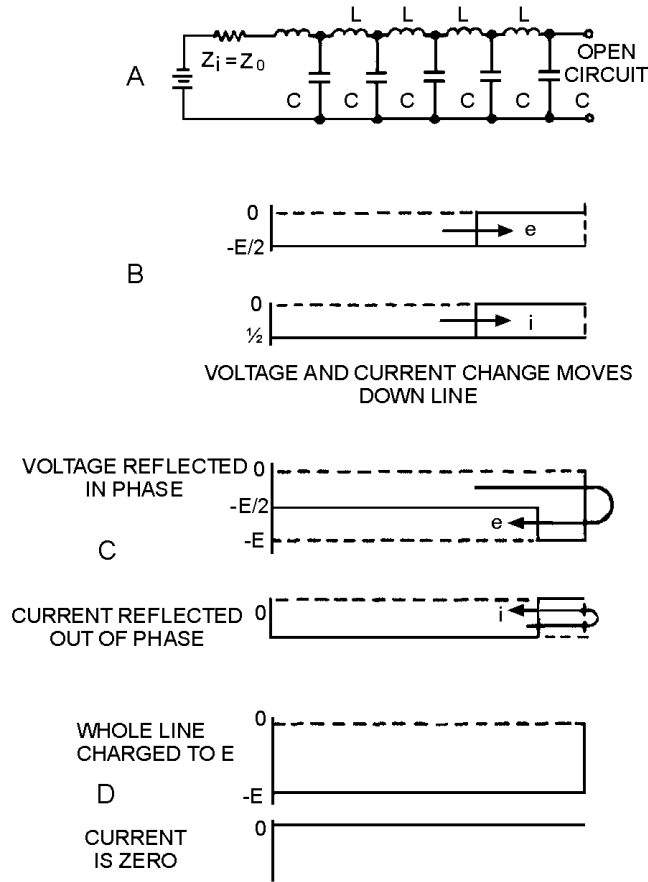

Figure 3-24.—Reflection from an open-ended line.

When the battery is connected to the sending end as shown, a negative voltage moves down the line. This voltage charges each capacitor, in turn, through the preceding inductor. Since Z_i equals Z_0 , one-half the applied voltage will appear across the internal battery impedance, Z_i , and one-half across the impedance of the line, Z_0 . Each capacitor is then charged to $E/2$ (view B). When the last capacitor in the line is charged, there is no voltage across the last inductor and current flow through the last inductor stops. With no current flow to maintain it, the magnetic field in the last inductor collapses and forces current to continue to flow in the same direction into the last capacitor. Because the direction of current has not changed, the capacitor charges in the same direction, thereby increasing the charge in the capacitor. Since the energy in the magnetic field equals the energy in the capacitor, the energy transfer to the capacitor doubles the voltage across the capacitor. The last capacitor is now charged to E volts and the current in the last inductor drops to zero.

At this point, the same process takes place with the next to the last inductor and capacitor. When the magnetic field about the inductor collapses, current continues to flow into the next to the last capacitor, charging it to E volts. This action continues backward down the line until the first capacitor has been fully charged to the applied voltage. This change of voltage, moving backward down the line, can be thought of in the following manner. The voltage, arriving at the end of the line, finds no place to go and returns to the sending end with the same polarity (view C). Such action is called REFLECTION.

When a reflection of voltage occurs on an open-ended line, the polarity is unchanged. The voltage change moves back to the source, charging each capacitor in turn until the first capacitor is charged to the

source voltage and the action stops (view D). As each capacitor is charged, current in each inductor drops to zero, effectively reflecting the current with the opposite polarity (view C). Reflected current of opposite polarity cancels the original current at each point, and the current drops to zero at that point. When the last capacitor is charged, the current from the source stops flowing (view D).

Important facts to remember in the reflection of dc voltages in open-ended lines are:

- Voltage is reflected from an open end without change in polarity, amplitude, or shape.
- Current is reflected from an open end with opposite polarity and without change in amplitude or shape.

REFLECTION OF DC VOLTAGE FROM A SHORT CIRCUIT

A SHORT-CIRCUITED line affects voltage change differently from the way an open-circuited line affects it. The voltage across a perfect short circuit must be zero; therefore, no power can be absorbed in the short, and the energy is reflected toward the generator.

The initial circuit is shown in figure 3-25, view A. The initial voltage and current waves (view B) are the same as those given for an infinite line. In a short-circuited line the voltage change arrives at the last inductor in the same manner as the waves on an open-ended line. In this case, however, there is no capacitor to charge. The current through the final inductor produces a voltage with the polarity shown in view C. When the field collapses, the inductor acts as a battery and forces current through the capacitor in the opposite direction, causing it to discharge (view D). Since the amount of energy stored in the magnetic field is the same as that in the capacitor, the capacitor discharges to zero.

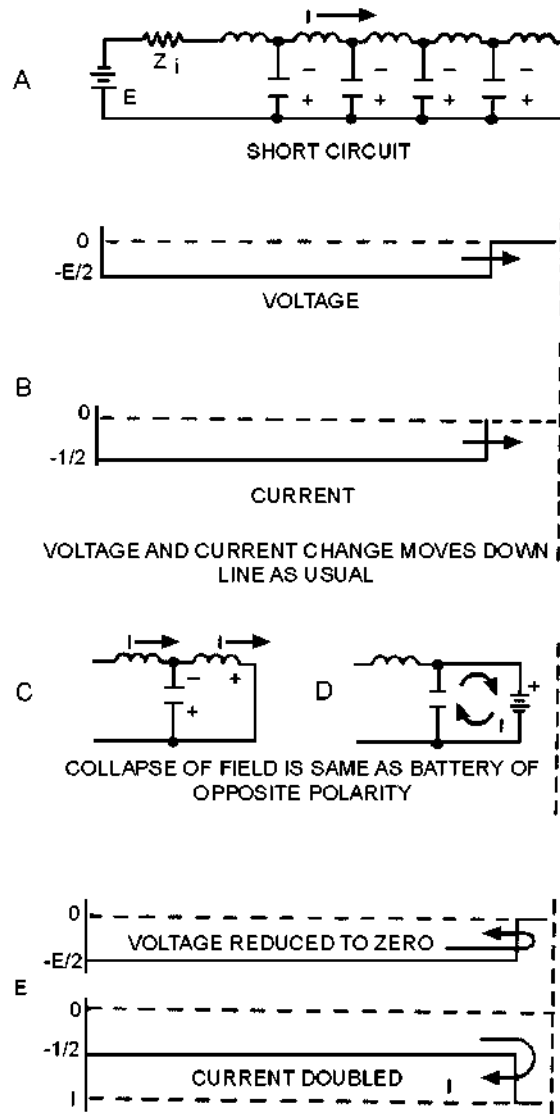

Figure 3-25.—Reflection from a short-circuited line.

Now there is no voltage to maintain the current through the next to the last inductor. Therefore, this inductor discharges the next to the last capacitor.

As each capacitor is discharged to zero, the next inductor effectively becomes a new source of voltage. The amplitude of each of these voltages is equal to $E/2$, but the polarity is the opposite of the battery at the input end of the line. The collapsing field around each inductor, in turn, produces a voltage that forces the current to continue flowing in the same direction, adding to the current from the source to make it $2I$. This action continues until all the capacitors are discharged (view E).

Reflected waves from a short-circuited transmission line are characterized as follows:

- The reflected voltage has the opposite polarity but the same amplitude as the incident wave.
- The reflected current has the same polarity and the same amplitude as the incident current.

REFLECTION OF AC VOLTAGE FROM AN OPEN CIRCUIT

In most cases where rf lines are used, the voltages applied to the sending end are ac voltages. The action at the receiving end of the line is exactly the same for ac as for dc. In the open-ended line, shown in figure 3-26, view A, the generated ac voltage is distributed along the line, shown in view B. This voltage is distributed in such a way that as each instantaneous voltage arrives at the end, it is reflected with the same polarity and amplitude. When ac is used, this reflection is in phase. Each of the reflected voltages travels back along the line until it reaches the generator. If the generator impedance is the same as the line impedance, energy arriving at the generator is absorbed and not reflected again. Now two voltages are on the line.

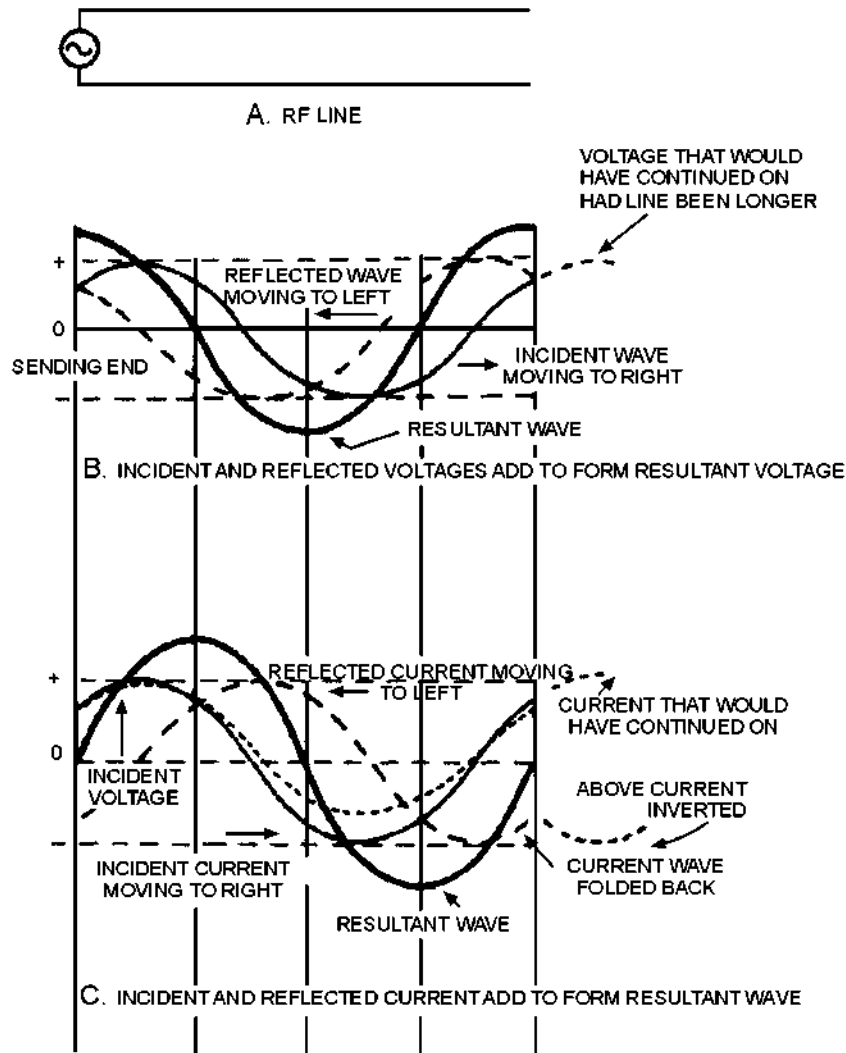

Figure 3-26.—Formation of standing waves.

View B shows how two waves of the same frequency and amplitude moving in opposite directions on the same conductor will combine to form a resultant wave. The small solid line is moving steadily from left to right and is the INCIDENT WAVE (from the source). The broken-line waveform is moving from right to left and is the REFLECTED WAVE. The resultant waveform, the heavy line, is found by algebraically adding instantaneous values of the two waveforms. The resultant waveform has an

instantaneous peak amplitude that is equal to the sum of the peak amplitudes of the incident and reflected waves. Since most indicating instruments are unable to separate these voltages, they show the vector sum. An oscilloscope is usually used to study the instantaneous voltages on rf lines.

Since two waves of voltage are moving on the line, you need to know how to distinguish between the two. The voltages moving toward the receiving end are called **INCIDENT VOLTAGES**, and the whole waveshape is called the **INCIDENT WAVE**. The wave moving back to the sending end after reflection is called the **REFLECTED WAVE**. The resultant voltage curve (view B of figure 3-26) shows that the voltage is maximum at the end of the line, a condition that occurs across an open circuit.

Another step in investigating the open-circuited rf line is to see how the current waves act. The incident current wave is the solid line in figure 3-26, view C. The voltage is represented by the dotted line. The current is in phase with the voltage while traveling toward the receiving end. At the end of the line, the current is reflected in the opposite polarity; that is, it is shifted 180 degrees in phase, but its amplitude remains the same. The reflected wave of current is shown by dashed lines in view C. The heavy-line curve represents the sum of the two instantaneous currents and is the resultant wave. Notice that current is zero at the end of the line. This is reasonable, since there can be no current flow through an open circuit.

Views B and C of figure 3-26 show the voltage and current distribution along a transmission line at a point about $1/8$ after a maximum voltage or current reaches the end of the line. Since the instantaneous values are continuously changing during the generation of a complete cycle, a large number of these pictures are required to show the many different relationships.

Figure 3-27 shows the incident and reflected waveshapes at several different times. The diagrams in the left column of figure 3-27 (representing *voltage*) show the incident wave and its reflection without change in polarity. In figure 3-27, waveform (1), the incident wave and the reflected wave are added algebraically to produce the resultant wave indicated by the heavy line. In waveform (2), a zero point preceding the negative-going cycle of the incident wave is at the end of the line. The reflected wave and incident wave are 180 degrees out of phase at all points. (The reflected wave is the positive cycle that just preceded the negative cycle now approaching the end of the line.) The resultant of the incident and reflected waves is zero at all points along the line. In waveform (3), the waves have moved $1/8\lambda$ along the line; the incident wave has moved 45 degrees to the right, and the reflected wave has moved 45 degrees to the left. The resultant voltage, shown by the heavy line, has a maximum negative at the end of the line and a maximum positive $1/2\lambda$ from the end of the line.

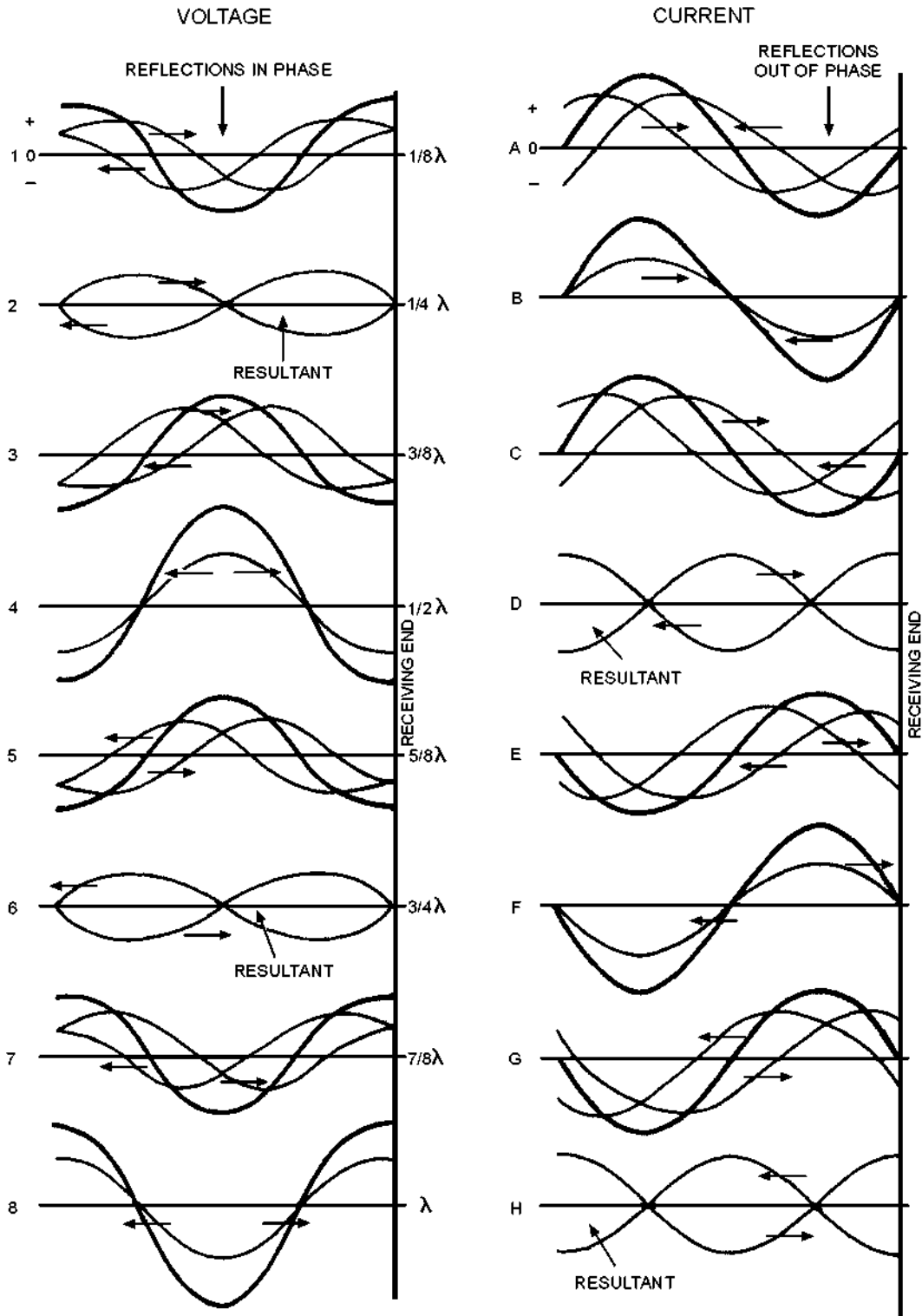

Figure 3-27.—Instantaneous values of incident and reflected waves on an open-ended line.

In waveform (4), the incident wave is at a maximum negative value at the end of the line. The wave has moved another 45 degrees to the right from the wave in the preceding illustration. The reflected wave has also moved 45 degrees, but to the left. The reflected wave is in phase with the incident wave. The resultant of these two waves, shown by the dark line, again has a negative maximum at the end of the line and a positive maximum $1/2\lambda$ from the end of the line. Notice that these maxima have a greater amplitude than those in waveform (3).

In waveform (5), the incident wave has moved another 45 degrees to the right and the reflected wave 45 degrees to the left. The resultant again is maximum negative at the end and positive maximum $1/2\lambda$ from the end. The maxima are lower than those in waveform (4). In waveform (6), the incident and reflected wave have moved another $1/8\lambda$. The two waves again are 180 degrees out of phase, giving a resultant wave with no amplitude. The incident and reflected waves continue moving in opposite directions, adding to produce the resultant waveshapes shown in waveforms (7) and (8). Notice that the maximum voltage in each resultant wave is at the end and $1/2\lambda$ from the end.

Study each part of figure 3-27 carefully and you will get a clear picture of how the resultant waveforms of voltage are produced. You will also see that the resultant voltage wave on an open-ended line is always zero at $1/4\lambda$ and $3/4\lambda$ from the end of the transmission line. Since the zero and maximum points are always in the same place, the resultant of the incident and the reflected wave is called a **STANDING WAVE** of voltage.

The right-hand column in figure 3-27 shows the *current* waveshapes on the open-ended line. Since the current is reflected out of phase at an open end, the resultant waveshapes differ from those for voltage. The two out-of-phase components always cancel at the end of the transmission line, so the resultant is always zero at that point. If you check all the resultant waveshapes shown in the right-hand column of figure 3-27, you will see that a zero point always occurs at the end and at a point $1/2\lambda$ from the end. Maximum voltages occur $1/4\lambda$ and $3/4\lambda$ from the end.

When an ac meter is used to measure the voltages and currents along a line, the polarity is not indicated. If you plot all the current and voltage readings along the length of the line, you will get curves like the ones shown in figure 3-28. Notice that all are positive. These curves are the conventional method of showing current and voltage standing waves on rf lines.



Figure 3-28.—Conventional picture of standing waves.

When an rf line is terminated in a short circuit, reflection is complete, but the effect on voltage and current differs from that in an open-ended line. Voltage is reflected in opposite phase, while current is reflected in phase. Again refer to the series of pictures shown in figure 3-27. However, this time the left column represents *current*, since it shows reflection in phase; and the right column of pictures now represents the *voltage* changes on the shorted line, since it shows reflection out of phase.

The composite diagram in figure 3-29 shows all resultant curves on a full-wavelength section of line over a complete cycle. Notice that the amplitude of the voltage varies between zero and maximum in both directions at the center and at both ends as well but, one-fourth of the distance from each end the voltage is always zero. The resultant waveshape is referred to as a standing wave of voltage. Standing waves, then, are caused by reflections, which occur only when the line is not terminated in its characteristic impedance.

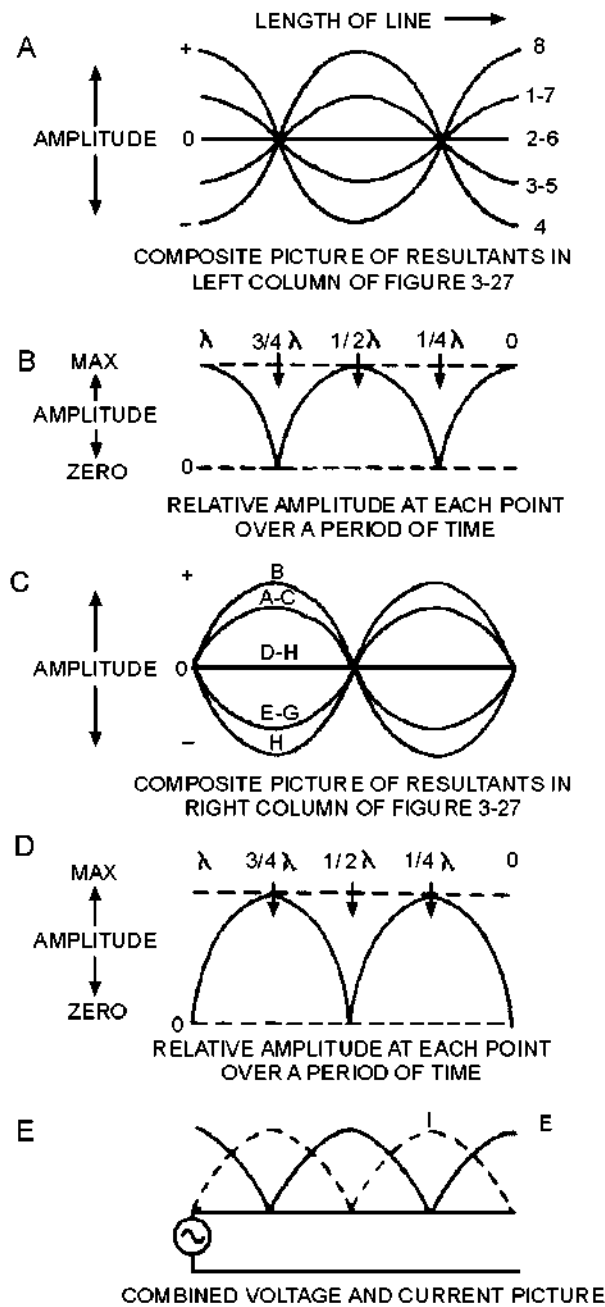

Figure 3-29.—Composite results of instantaneous waves.

The voltage at the center and the ends varies at a sinusoidal rate between the limits shown. At the one-fourth the three-fourths points, the voltage is always zero. A continuous series of diagrams such as these is difficult to see with conventional test equipment, which reads the effective or average voltage over several cycles. The curve of amplitude over the length of line for several cycles is shown in figure 3-29, view B. A meter will read zero at the points shown and will show a maximum voltage at the center, no matter how many cycles pass.

As shown in view D, the amplitude varies along the length of the line. In this case it is zero at the end and center but maximum at the one-fourth and three-fourths points. The entire diagram of the open-ended line conditions is shown in view E. The standing waves of voltage and current appear together. Observe that one is maximum when the other is minimum. The current and voltage standing waves are one-quarter cycle, or 90 degrees, out of phase with one another.

REFLECTION OF AC VOLTAGE FROM A SHORT CIRCUIT

Reflection is complete when an rf line is terminated in a short circuit, but the effect on voltage and current differs from the effect obtained in an open-ended line. Voltage is reflected in opposite phase, while current is reflected in phase. Again look at the series of diagrams in figure 3-27. The left column represents current, and the right column shows voltage changes on the shorted line. The standard representation of standing waves on a shorted line is shown in figure 3-30; the voltage is a solid line, and the current is a dashed line. The voltage is zero at the end and center ($1/2\lambda$) and maximum at the $1/4\lambda$ and $3/4\lambda$ points, while the current is maximum at the end and center and minimum at the $1/4\lambda$ and $3/4\lambda$ points.

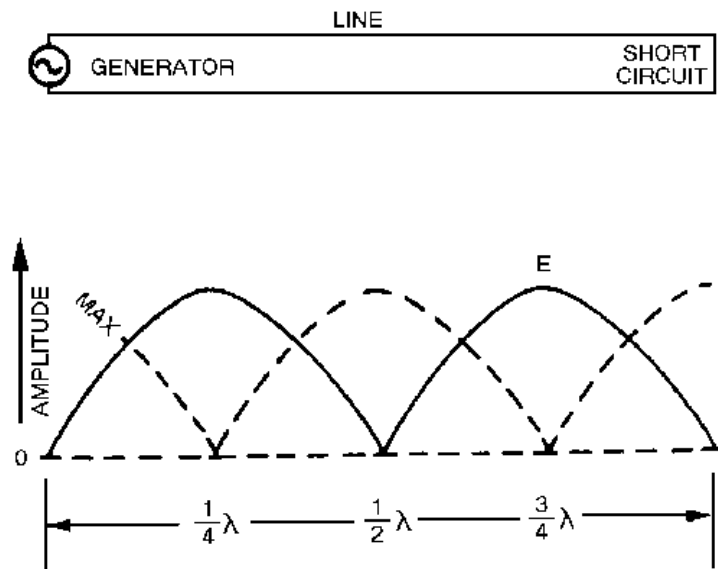

Figure 3-30.—Standing waves on a shorted line.

As we discussed voltage and current waves on transmission lines, we pointed out several differences between open and shorted lines. Basic differences also appear in the standing-wave patterns for open and shorted lines. You can see these differences by comparing figure 3-29, view E, and figure 3-30. Notice that the current and voltage standing waves are shifted 90 degrees with respect to the termination. At the open end of a line, voltage is maximum (zero if there are no losses in the line). At a short circuit, current is maximum and voltage is minimum.

Q23. Two types of waves are formed on a transmission line. What names are given to these waves?

Q24. In figure 3-27, which waveforms on the left have a resultant wave of zero, and what is indicated by these waves?

Q25. On an open-ended transmission line, the voltage is always zero at what distance from each end of the line?

TERMINATING A TRANSMISSION LINE

A transmission line is either NONRESONANT or RESONANT. First, let us define the terms nonresonant lines and resonant lines. A nonresonant line is a line that has no standing waves of current and voltage. A resonant line is a line that has standing waves of current and voltage.

Nonresonant Lines

A nonresonant line is either infinitely long or terminated in its characteristic impedance. Since no reflections occur, all the energy traveling down the line is absorbed by the load which terminates the line. Since no standing waves are present, this type of line is sometimes spoken of as a FLAT line. In addition, because the load impedance of such a line is equal to Z_0 , no special tuning devices are required to effect a maximum power transfer; hence, the line is also called an UNTUNED line.

Resonant Lines

A resonant line has a finite length and is not terminated in its characteristic impedance. Therefore reflections of energy do occur. The load impedance is different from the Z_0 of the line; therefore, the input impedance may not be purely resistive but may have reactive components. Tuning devices are used to eliminate the reactance and to bring about maximum power transfer from the source to the line. Therefore, a resonant line is sometimes called a TUNED line. The line also may be used for a resonant or tuned circuit.

A resonant line is sometimes said to be resonant at an applied frequency. This means that at one frequency the line acts as a resonant circuit. It may act either as a high-resistive circuit (parallel resonant) or as a low-resistive circuit (series resonant). The line may be made to act in this manner by either open- or short-circuiting it at the output end and cutting it to some multiple of a quarter-wavelength.

At the points of voltage maxima and minima on a short-circuited or open-circuited line, the line impedance is resistive. On a short-circuited line, each point at an odd number of quarter-wavelengths from the receiving end has a high impedance (figure 3-31, view A). If the frequency of the applied voltage to the line is varied, this impedance decreases as the effective length of the line changes. This variation is exactly the same as the change in the impedance of a parallel-resonant circuit when the applied frequency is varied.

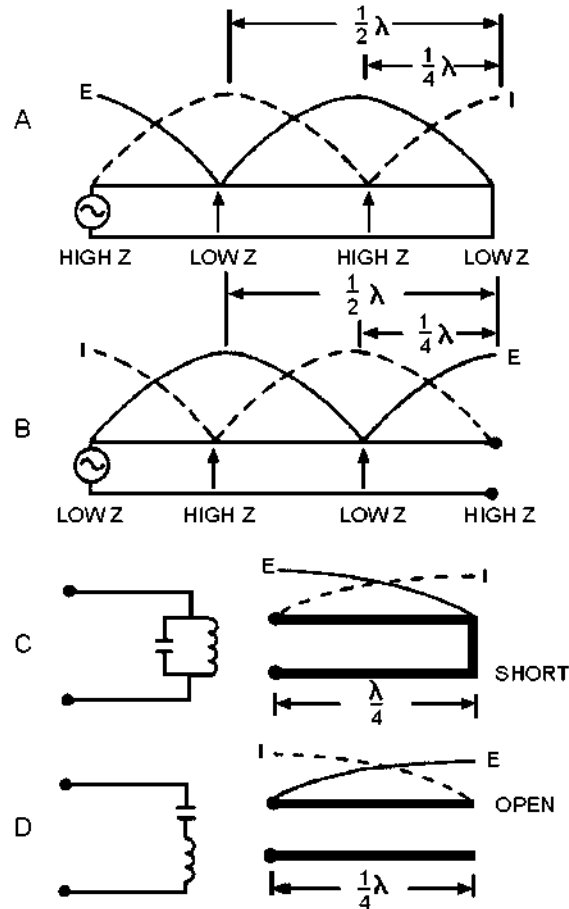

Figure 3-31.—Sending-end impedance of various lengths and terminations.

At all even numbered quarter-wavelength points from the short circuit, the impedance is extremely low. When the frequency of the voltage applied to the line is varied, the impedance at these points increases just as the impedance of a series-resonant circuit varies when the frequency applied to it is changed. The same is true for an open-ended line (figure 3-31, view B) except that the points of high and low impedance are reversed.

At this point let us review some of the characteristics of resonant circuits so we can see how resonant line sections may be used in place of LC circuits.

A PARALLEL-RESONANT circuit has the following characteristics:

- At resonance the impedance appears as a very high resistance. A loss-free circuit has infinite impedance (an open circuit). Other than at resonance, the impedance decreases rapidly.
- If the circuit is resonant at a point above the generator frequency (the generator frequency is too low), more current flows through the coil than through the capacitor. This happens because X_L decreases with a decrease in frequency but X_C increases.

A SERIES-RESONANT circuit has these characteristics:

- At resonance the impedance appears as a very low resistance. A loss-free circuit has zero impedance (a short circuit). Other than at resonance the impedance increases rapidly.
- If the circuit is resonant at a point above the generator frequency (the generator frequency is too low), then X_C is larger than X_L and the circuit acts capacitively.
- If the circuit is resonant at a point below the generator frequency (the generator frequency is too high), then X_L is larger than X_C and the circuit acts inductively.

Since the impedance a generator sees at the quarter-wave point in a shorted line is that of a parallel-resonant circuit, a shorted quarter-wave-length of line may be used as a parallel-resonant circuit (figure 3-31, view C). An open quarter-wavelength of line may be used as a series-resonant circuit (view D). The Q of such a resonant line is much greater than can be obtained with lumped capacitance and inductance.

Impedance for Various Lengths of Open Lines

In figure 3-32, the impedance (Z) the generator sees for various lengths of line is shown at the top. The curves above the letters of various heights show the relative value of the impedances presented to the generator for the various line lengths. The circuit symbols indicate the equivalent electrical circuits for the transmission lines at each particular length. The standing waves of voltage and current are shown on each length of line.

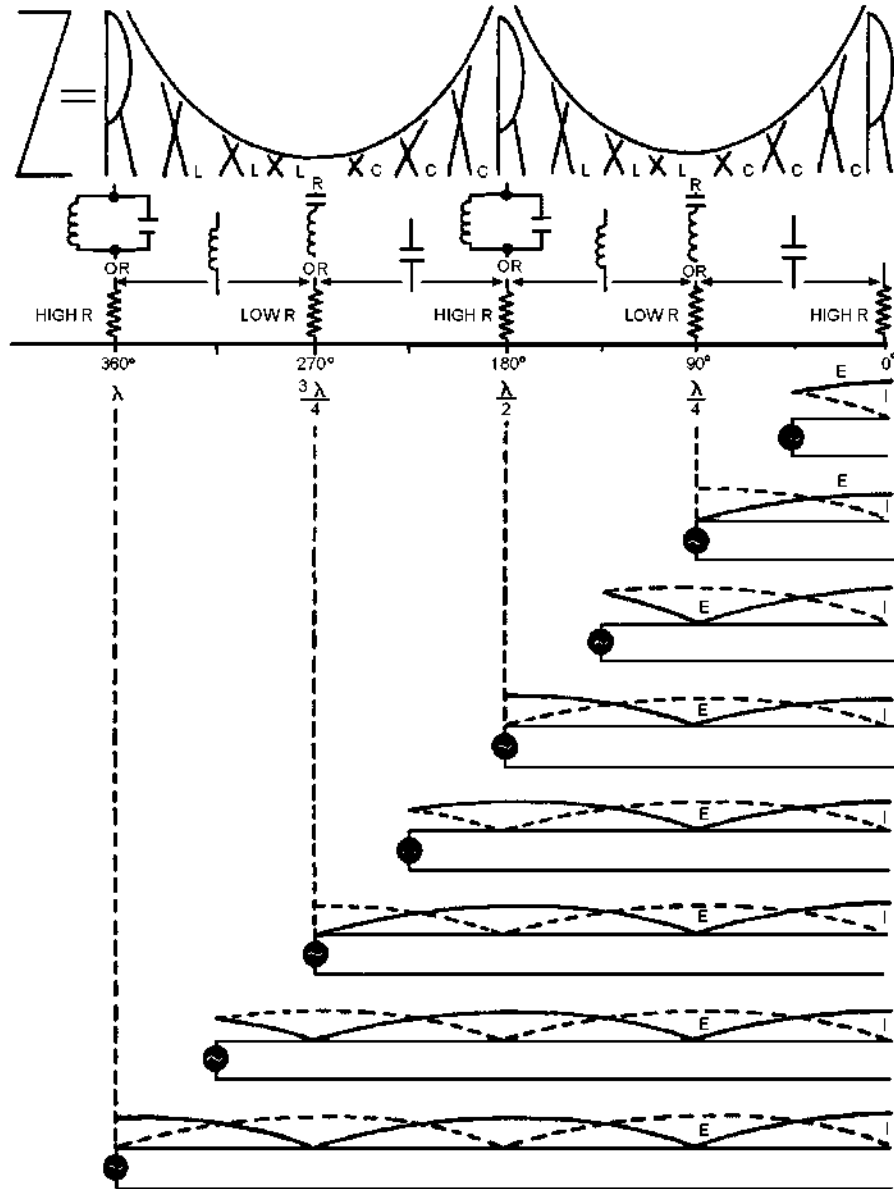

Figure 3-32.—Voltage, current, and impedance on open line.

At all odd quarter-wave points ($1/4\lambda$, $3/4\lambda$, etc.), the voltage is minimum, the current is maximum, and the impedance is minimum. Thus, at all odd quarter-wave points, the open-ended transmission line acts as a series-resonant circuit. The impedance is equivalent to a very low resistance, prevented from being zero only by small circuit losses.

At all even quarter-wave points ($1/2\lambda$, 1λ , $3/2\lambda$, etc.), the voltage is maximum, the current is minimum, and the impedance is maximum. Comparison of the line with an LC resonant circuit shows that at an even number of quarter-wavelengths, an open line acts as a parallel-resonant circuit. The impedance is therefore an extremely high resistance.

In addition, resonant open lines may also act as nearly pure capacitances or inductances. The illustration shows that an open line less than a quarter-wavelength long acts as a capacitance. Also, it acts

as an inductance from 1/4 to 1/2 wavelength, as a capacitance from 1/2 to 3/4 wavelength, and as an inductance from 3/4 to 1 wavelength, etc. A number of open transmission lines, with their equivalent circuits, are shown in the illustration.

Impedance of Various Lengths of Shorted Lines

Follow figure 3-33 as we study the shorted line. At the odd quarter-wavelength points, the voltage is high, the current is low, and the impedance is high. Since these conditions are similar to those found in a parallel-resonant circuit, the shorted transmission line acts as a parallel-resonant circuit at these lengths.

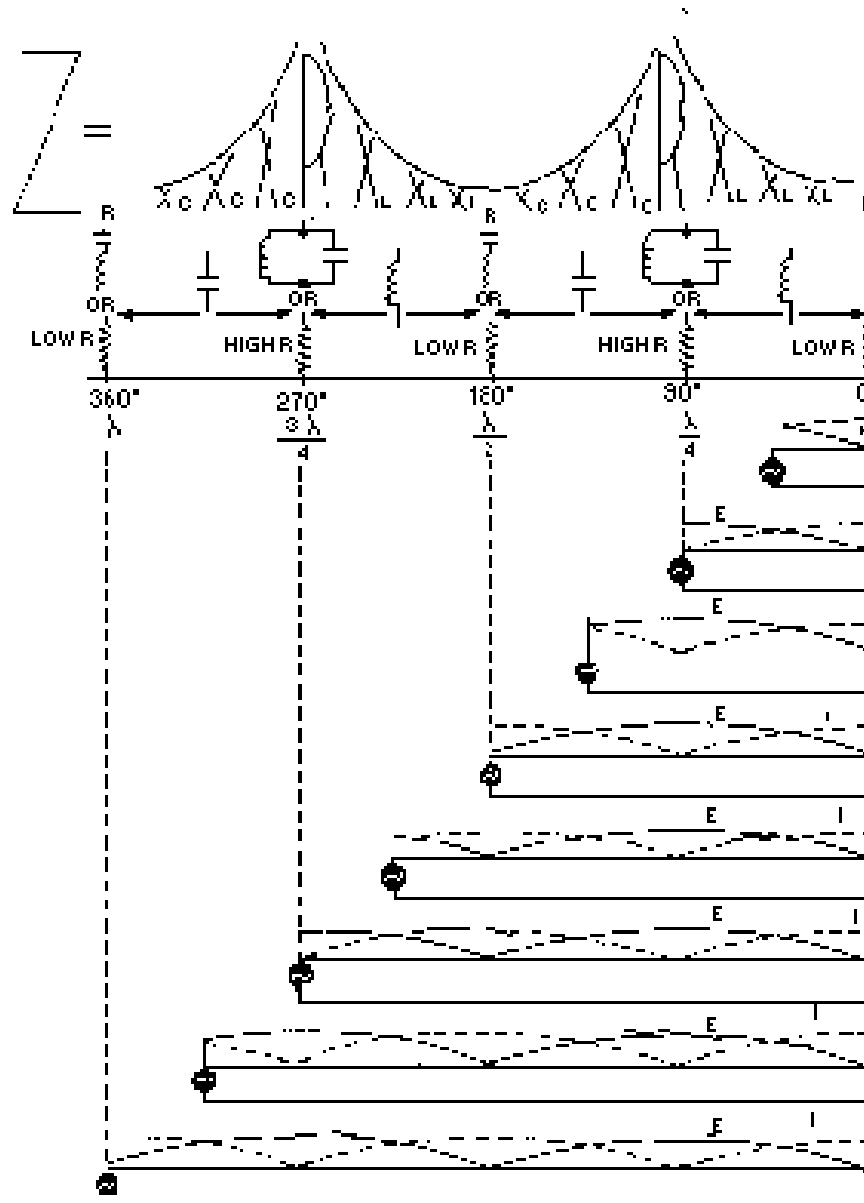

Figure 3-33.—Voltage, current, and impedance on shorted line.

At the even quarter-wave points voltage is minimum, current is maximum, and impedance is minimum. Since these characteristics are similar to those of a series-resonant LC circuit, a shorted transmission line whose length is an even number of quarter-wavelengths acts as a series-resonant circuit.

Resonant shorted lines, like open-end lines, also may act as pure capacitances or inductances. The illustration shows that a shorted line less than $1/4$ wavelength long acts as an inductance. A shorted line with a length of from $1/4$ to $1/2$ wavelength acts as a capacitance. From $1/2$ to $3/4$ wavelength, the line acts as an inductance; and from $3/4$ to 1 wavelength, it acts as a capacitance, and so on. The equivalent circuits of shorted lines of various lengths are shown in the illustration. Thus, properly chosen line segments may be used as parallel-resonant, series-resonant, inductive, or capacitive circuits.

STANDING WAVES ON A TRANSMISSION LINE

There is a large variety of terminations for rf lines. Each type of termination has a characteristic effect on the standing waves on the line. From the nature of the standing waves, you can determine the type of termination that produces the waves.

TERMINATION IN Z_0

Termination in Z_0 (characteristic impedance) will cause a constant reading on an ac meter when it is moved along the length of the line. As illustrated in figure 3-34, view A, the curve, provided there are no losses in the line, will be a straight line. If there are losses in the line, the amplitude of the voltage and current will diminish as they move down the line (view B). The losses are due to dc resistance in the line itself.

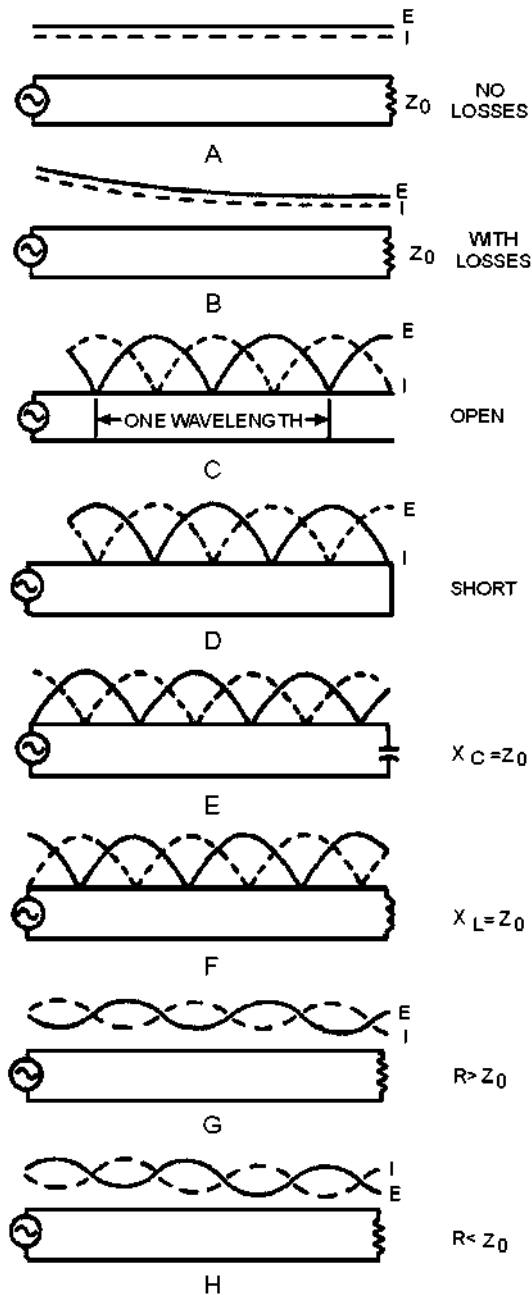

Figure 3-34.—Effects of various terminations on standing waves.

TERMINATION IN AN OPEN CIRCUIT

In an open-circuited rf line (figure 3-34, view C), the voltage is maximum at the end, but the current is minimum. The distance between two adjacent zero current points is $1/2\lambda$, and the distance between alternate zero current points is 1λ . The voltage is zero at a distance of $1/4\lambda$ from the end of the line. This is true at any frequency. A voltage peak occurs at the end of the line, at $1/2\lambda$ from the end, and at each $1/2\lambda$ thereafter.

TERMINATION IN A SHORT CIRCUIT

On the line terminated in a short circuit, shown in figure 3-34, view D, the voltage is zero at the end and maximum at $1/4\lambda$ from the end. The current is maximum at the end, zero at $1/4\lambda$ from the end, and alternately maximum and zero every $1/4\lambda$ thereafter.

TERMINATION IN CAPACITANCE

When a line is terminated in capacitance, the capacitor does not absorb energy, but returns all of the energy to the circuit. This means there is 100 percent reflection. The current and voltage relationships are somewhat more involved than in previous types of termination. For this explanation, assume that the capacitive reactance is equal to the Z_0 of the line. Current and voltage are in phase when they arrive at the end of the line, but in flowing through the capacitor and the characteristic impedance (Z_0) connected in series, they shift in phase relationship. Current and voltage arrive in phase and leave out of phase. This results in the standing-wave configuration shown in figure 3-34, view E. The standing wave of voltage is minimum at a distance of exactly $1/8\lambda$ from the end. If the capacitive reactance is greater than Z_0 (smaller capacitance), the termination looks more like an open circuit; the voltage minimum moves away from the end. If the capacitive reactance is smaller than Z_0 , the minimum moves toward the end.

TERMINATION IN INDUCTANCE

When the line is terminated in an inductance, both the current and voltage shift in phase as they arrive at the end of the line. When X_L is equal to Z_0 , the resulting standing waves are as shown in figure 3-34, view F. The current minimum is located $1/8\lambda$ from the end of the line. When the inductive reactance is increased, the standing waves appear closer to the end. When the inductive reactance is decreased, the standing waves move away from the end of the line.

TERMINATION IN A RESISTANCE NOT EQUAL TO THE CHARACTERISTIC IMPEDANCE (Z_0)

Whenever the termination is not equal to Z_0 , reflections occur on the line. For example, if the terminating element contains resistance, it absorbs some energy, but if the resistive element does not equal the Z_0 of the line, some of the energy is reflected. The amount of voltage reflected may be found by using the equation:

$$E_r = E_i \left(\frac{R_L - Z_0}{R_L + Z_0} \right)$$

Where:

E_r = the reflected voltage

E_i = the incident voltage

R_L = the terminating resistance

Z_0 = the characteristic impedance of the line

If you try different values of R_L in the preceding equation, you will find that the reflected voltage is equal to the incident voltage only when R_L equals 0 or is infinitely large. When R_L equals Z_0 , no reflected voltage occurs. When R_L is greater than Z_0 , E_r is positive, but less than E_i . As R_L increases and

approaches an infinite value, E_R increases and approaches E_i in value. When R_L is smaller than Z_0 , E_R has a negative value. This means that the reflected voltage is of opposite polarity to the incident wave at the termination of the line. As R_L approaches zero, E_R approaches E_i in value. The smaller the value of E_R , the smaller is the peak amplitude of the standing waves and the higher are the minimum values.

TERMINATION IN A RESISTANCE GREATER THAN Z_0

When R_L is greater than Z_0 , the end of the line is somewhat like an open circuit; that is, standing waves appear on the line. The voltage maximum appears at the end of the line and also at half-wave intervals back from the end. The current is minimum (not zero) at the end of the line and maximum at the odd quarter-wave points. Since part of the power in the incident wave is consumed by the load resistance, the minimum voltage and current are less than for the standing waves on an open-ended line. Figure 3-34, view G, illustrates the standing waves for this condition.

TERMINATION IN A RESISTANCE LESS THAN Z_0

When R_L is less than Z_0 , the termination appears as a short circuit. The standing waves are shown in figure 3-34, view H. Notice that the line terminates in a current LOOP (peak) and a voltage NODE (minimum). The values of the maximum and minimum voltage and current approach those for a shorted line as the value of R_L approaches zero.

A line does not have to be any particular length to produce standing waves; however, it cannot be an infinite line. Voltage and current must be reflected to produce standing waves. For reflection to occur, a line must not be terminated in its characteristic impedance. Reflection occurs on lines terminated in opens, shorts, capacitances, and inductances, because no energy is absorbed by the load. If the line is terminated in a resistance not equal to the characteristic impedance of the line, some energy will be absorbed and the rest will be reflected.

The voltage and current relationships for open-ended and shorted lines are opposite to each other, as shown in figure 3-34, views C and D. The points of maximum and minimum voltage and current are determined from the output end of the line, because reflection always begins at that end.

Q26. A nonresonant line is a line that has no standing waves of current and voltage on it and is considered to be flat. Why is this true?

Q27. On an open line, the voltage and impedance are maximum at what points on the line?

STANDING-WAVE RATIO

The measurement of standing waves on a transmission line yields information about equipment operating conditions. Maximum power is absorbed by the load when $Z_L = Z_0$. If a line has no standing waves, the termination for that line is correct and maximum power transfer takes place.

You have probably noticed that the variation of standing waves shows how near the rf line is to being terminated in Z_0 . A wide variation in voltage along the length means a termination far from Z_0 . A small variation means termination near Z_0 . Therefore, the ratio of the maximum to the minimum is a measure of the perfection of the termination of a line. This ratio is called the STANDING-WAVE RATIO (swr) and is always expressed in whole numbers. For example, a ratio of 1:1 describes a line terminated in its characteristic impedance (Z_0).

Voltage Standing-Wave Ratio

The ratio of maximum voltage to minimum voltage on a line is called the VOLTAGE STANDING-WAVE RATIO (vswr). Therefore:

$$vswr = \frac{E_{max}}{E_{min}}$$

The vertical lines in the formula indicate that the enclosed quantities are absolute and that the two values are taken without regard to polarity. Depending on the nature of the standing waves, the numerical value of vswr ranges from a value of 1 ($Z_L = Z_0$, no standing waves) to an infinite value for theoretically complete reflection. Since there is always a small loss on a line, the minimum voltage is never zero and the vswr is always some finite value. However, if the vswr is to be a useful quantity, the power losses along the line must be small in comparison to the transmitted power.

Power Standing-Wave Ratio

The square of the voltage standing-wave ratio is called the POWER STANDING-WAVE RATIO (pswr). Therefore:

$$pswr = \frac{P_{max}}{P_{min}}$$

This ratio is useful because the instruments used to detect standing waves react to the square of the voltage. Since power is proportional to the square of the voltage, the ratio of the square of the maximum and minimum voltages is called the power standing-wave ratio. In a sense, the name is misleading because the power along a transmission line does not vary.

Current Standing-Wave Ratio

The ratio of maximum to minimum current along a transmission line is called CURRENT STANDING-WAVE RATIO (iswr). Therefore:

$$iswr = \frac{I_{max}}{I_{min}}$$

This ratio is the same as that for voltages. It can be used where measurements are made with loops that sample the magnetic field along a line. It gives the same results as vswr measurements.

Q28. At what point on an open-circuited rf line do voltage peaks occur?

Q29. What is the square of the voltage standing-wave ratio called?

Q30. What does vswr measure?

SUMMARY

This chapter has presented information on the characteristics of transmission lines. The information that follows summarizes the important points of this chapter.

TRANSMISSION LINES are devices for guiding electrical energy from one point to another.

INPUT IMPEDANCE is the ratio of voltage to current at the input end of a transmission line.

OUTPUT IMPEDANCE is the ratio of voltage to current at the output end of the line.

TWO-WIRE OPEN LINES are parallel lines and have uses such as power lines, rural telephone lines, and telegraph lines. This type of line has high radiation losses and is subject to noise pickup.

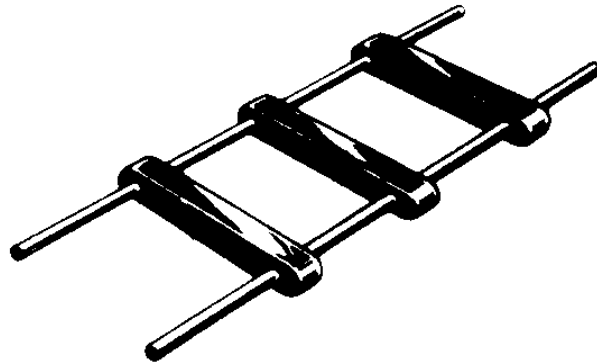

TWIN LEAD has parallel lines and is most often used to connect televisions to their antennas.

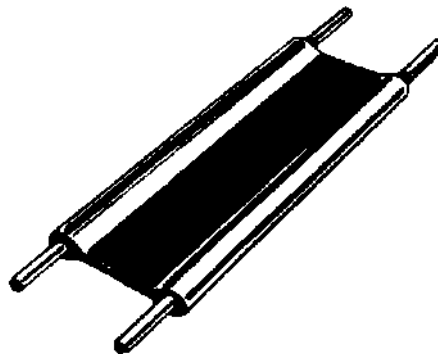

A **TWISTED PAIR** consists of two insulated wires twisted together. This line has high insulation loss.



A **SHIELDED PAIR** has parallel conductors separated by a solid dielectric and surrounded by copper braided tubing. The conductors are balanced to ground.

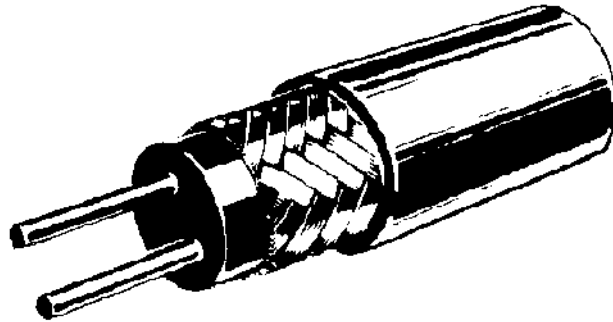

RIGID COAXIAL LINE contains two concentric conductors insulated from each other by spacers. Some rigid coaxial lines are pressurized with an inert gas to prevent moisture from entering. High-frequency losses are less than with other lines.

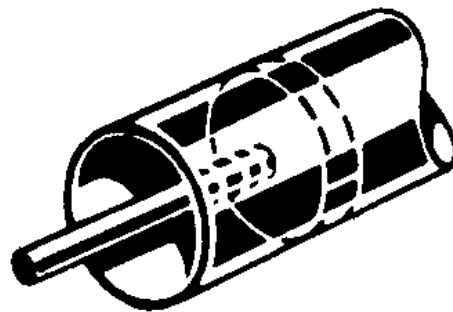

FLEXIBLE COAXIAL LINES consist of a flexible inner conductor and a concentric outer conductor of metal braid. The two are separated by a continuous insulating material.

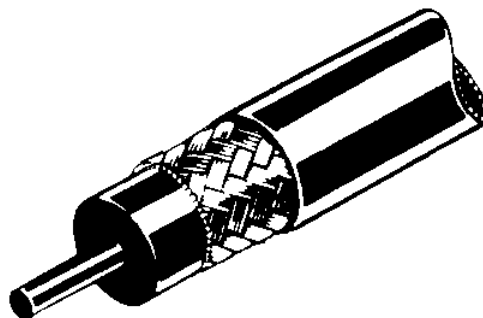

WAVEGUIDES are hollow metal tubes used to transfer energy from one point to another. The energy travels slower in a waveguide than in free space.

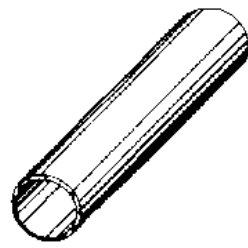

CYLINDRICAL

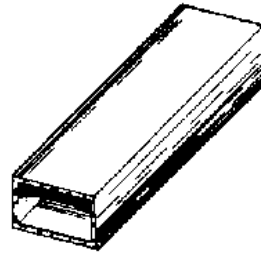

RECTANGULAR

COPPER LOSSES can result from power (I^2R) loss, in the form of heat, or skin effect. These losses decrease the conductivity of a line.

DIELECTRIC LOSSES are caused by the heating of the dielectric material between conductors, taking power from the source.

RADIATION and **INDUCTION LOSSES** are caused by part of the electromagnetic fields of a conductor being dissipated into space or nearby objects.

A transmission line is either electrically **LONG** or **SHORT** if its physical length is not equal to $1/4\lambda$ for the frequency it is to carry.

LUMPED CONSTANTS are theoretical properties (inductance, resistance, and capacitance) of a transmission line that are lumped into a single component.

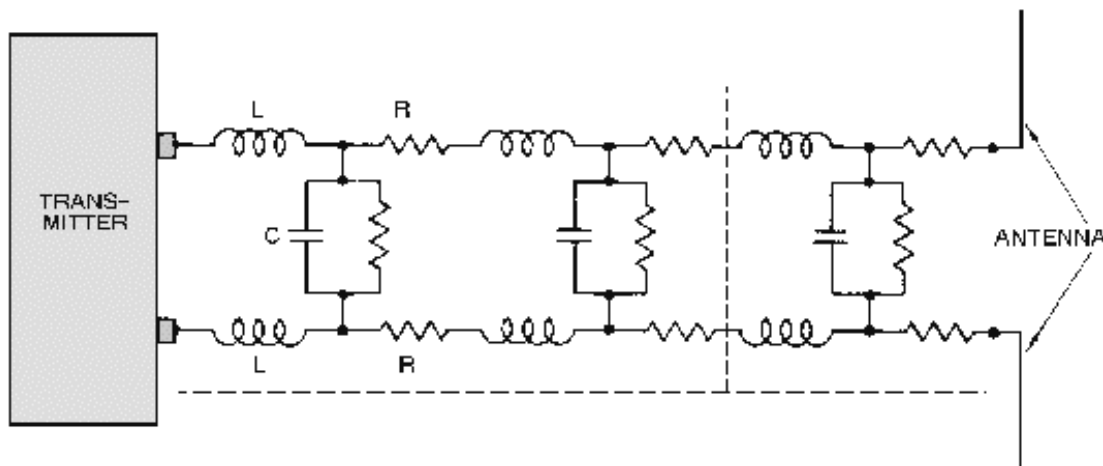

DISTRIBUTED CONSTANTS are constants of inductance, capacitance and resistance that are distributed along the transmission line.

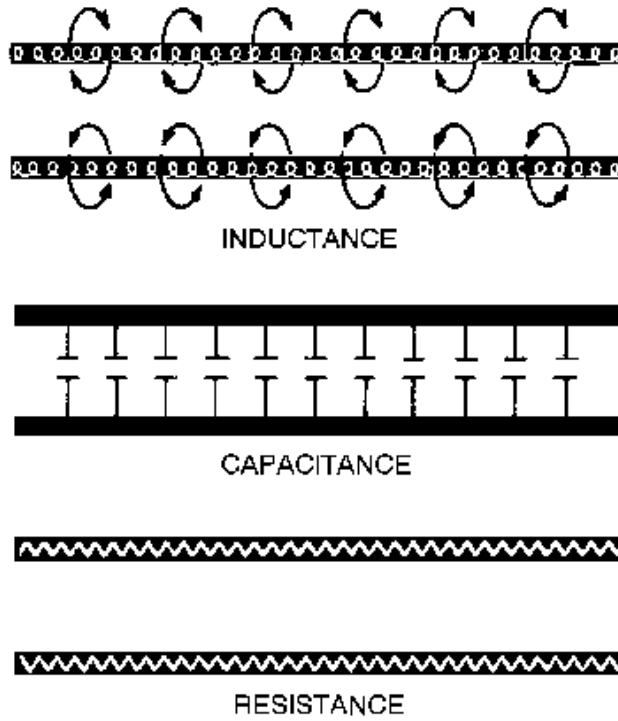

LEAKAGE CURRENT flows between the wires of a transmission line through the dielectric. The dielectric acts as a resistor.

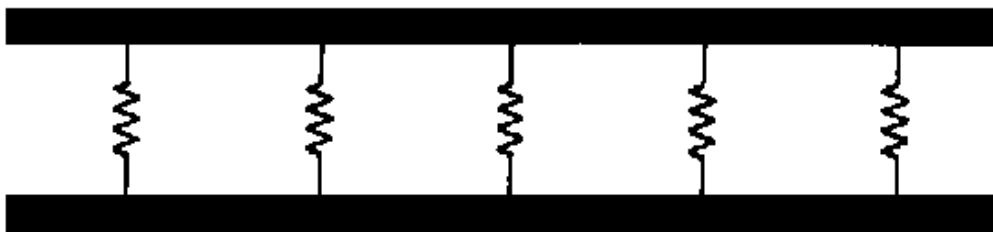

An **ELECTROMAGNETIC FIELD** exists along transmission line when current flows through it.

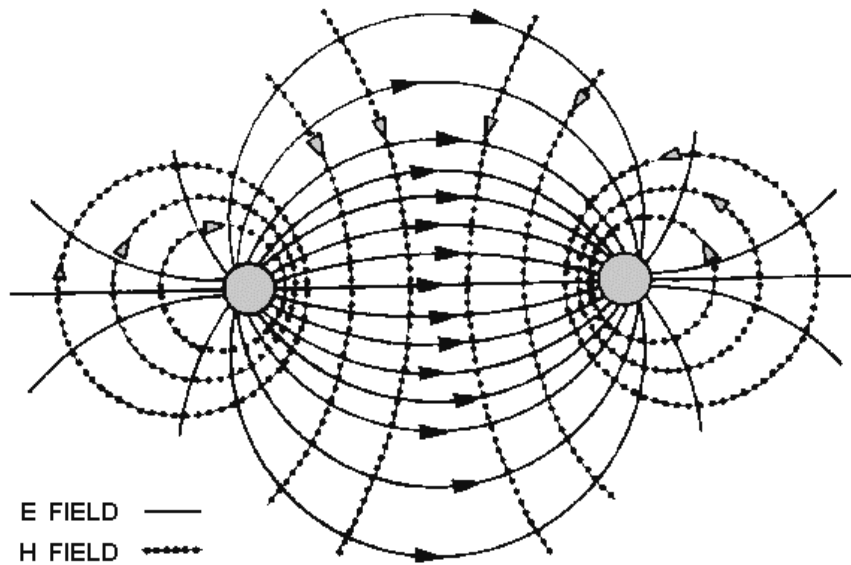

CHARACTERISTIC IMPEDANCE, Z_0 , is the ratio of E to I at every point along the line. For maximum transfer of electrical power, the characteristic impedance and load impedance must be matched.

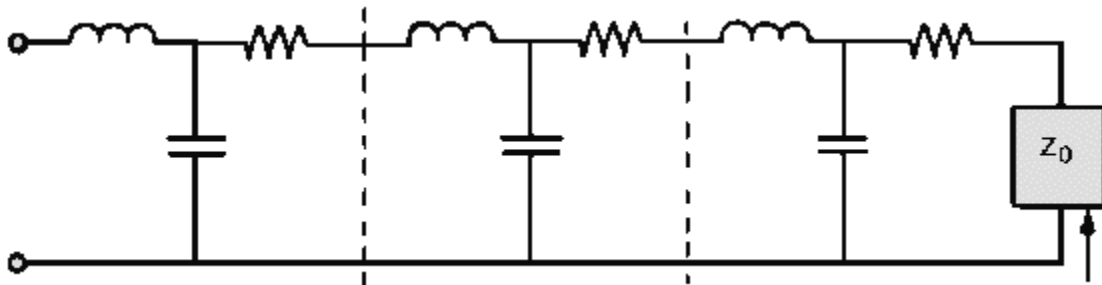

The **VELOCITY** at which a wave travels over a given length of transmission line can be found by using the formula:

$$V = \frac{D}{\sqrt{LC}}$$

A transmission line that is not terminated in its characteristic impedance is said to be **FINITE**.

When dc is applied to an **OPEN-ENDED** line, the voltage is reflected back from the open end without any change in polarity, amplitude, or shape. Current is reflected back with the same amplitude and shape but with opposite polarity.

When dc is applied to a **SHORT-CIRCUITED** line, the current is reflected back with the same amplitude, and polarity. The voltage is reflected back with the same amplitude but with opposite polarity.

When ac is applied to an **OPEN-END** line, voltage is always reflected back in phase with the incident wave and current is reflected back out of phase.

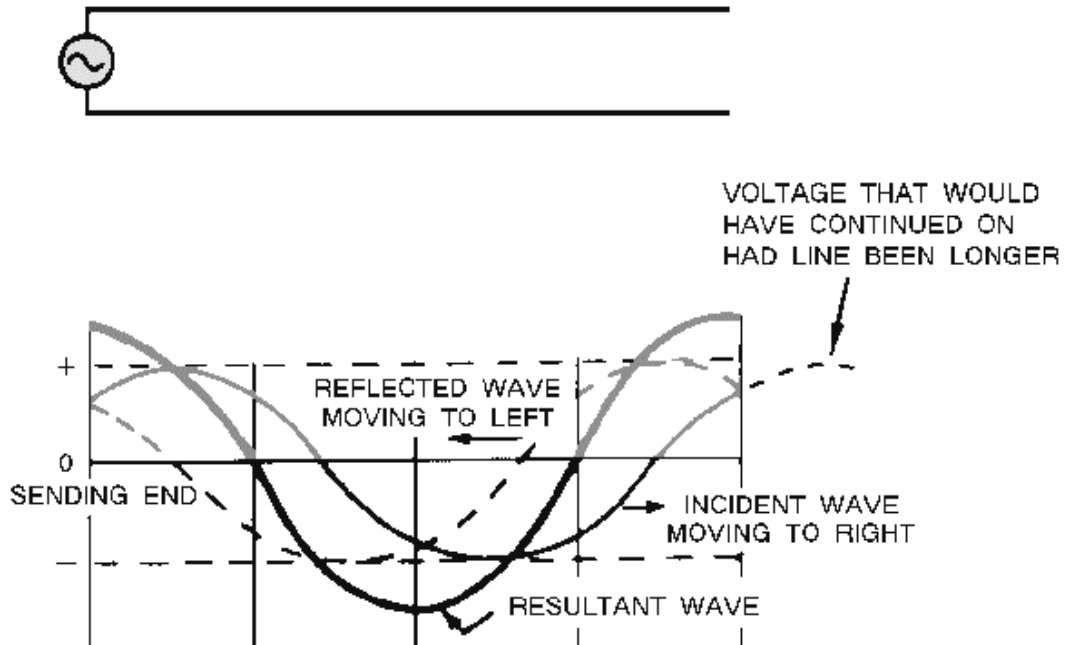

When ac is applied to a **SHORT-CIRCUITED** line, voltage is reflected in opposite phase, while current is reflected in phase.

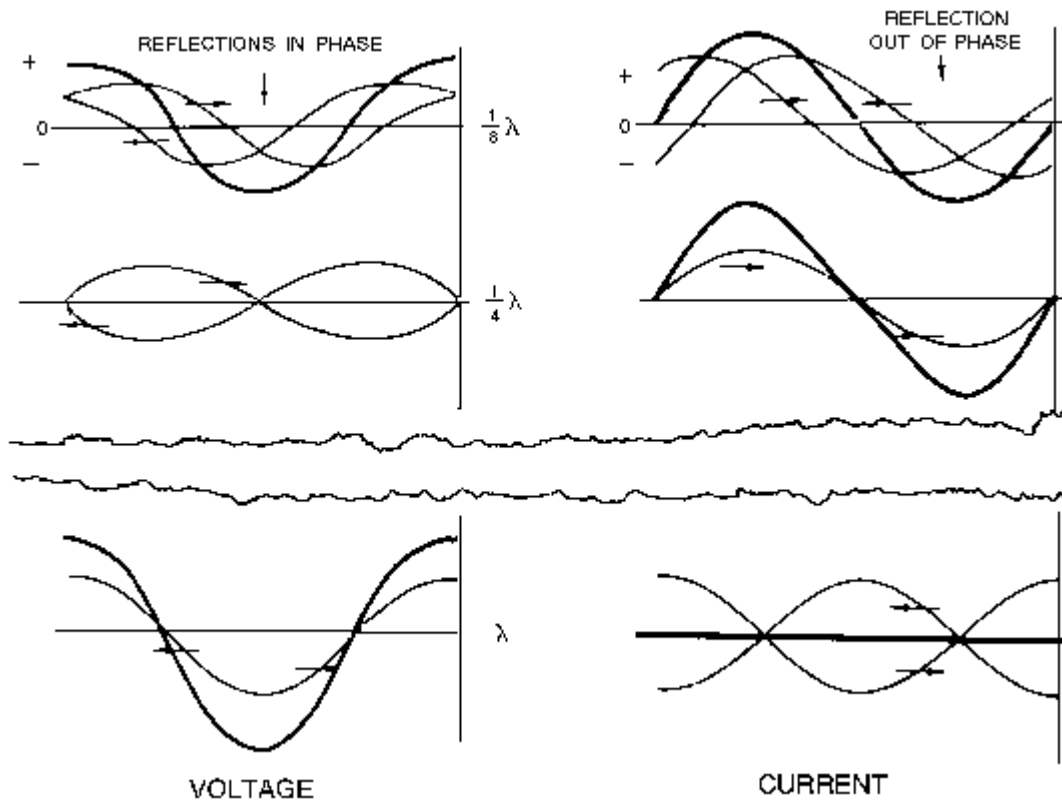

A **NONRESONANT** line has **NO STANDING WAVES** of current and voltage and is either infinitely long or terminated in its characteristic impedance.

A **RESONANT** line has **STANDING WAVES** of current and voltage and is of finite length and is **NOT** terminated in its characteristic impedance.

On an open-ended resonant line, and at all odd $1/4\lambda$ points, the voltage is minimum, the current is maximum, and the impedance is minimum. At all even $1/4\lambda$ points, the voltage is maximum, the current is minimum and the impedance is maximum.

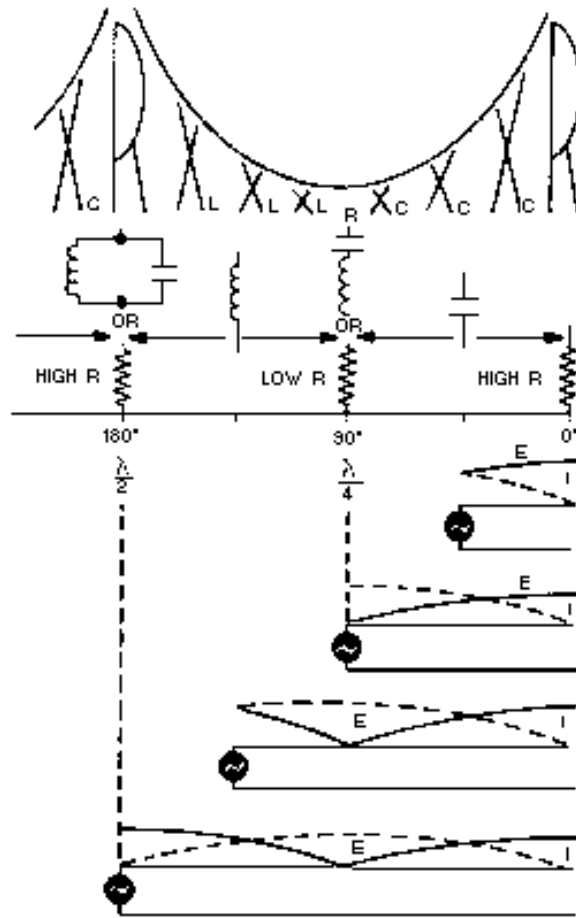

There are a variety of **TERMINATIONS** for rf lines. Each termination has an effect on the standing waves on the line.

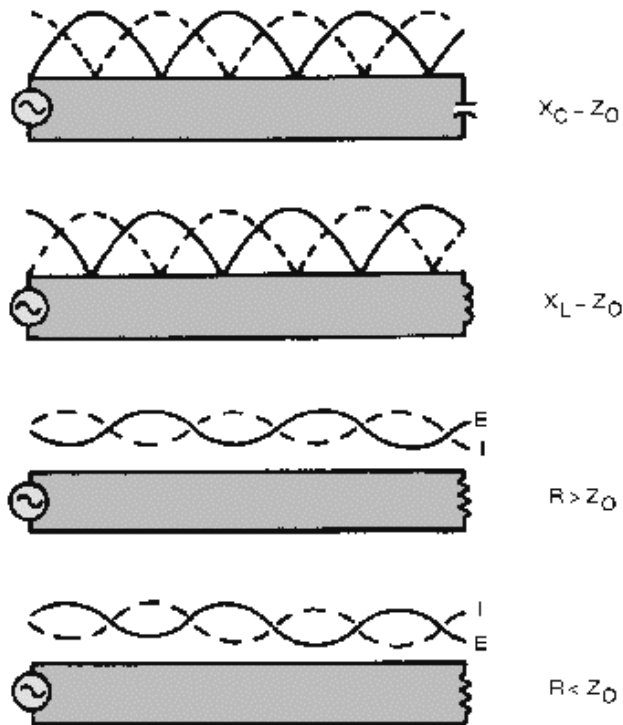

A transmission line can be terminated in its characteristic impedance as an open- or short-circuit, or in capacitance or inductance.

Whenever the termination on a transmission line is NOT EQUAL TO Z_0 , there are reflections on the line. The amount of voltage reflected may be found by using the equation:

$$E_r = E_i \left(\frac{R_L - Z_0}{R_L + Z_0} \right)$$

When the termination on a transmission line EQUALS Z_0 , there is NO reflected voltage.

The measurement of standing waves on a transmission line yields information about operating conditions. If there are NO standing waves, the termination for that line is correct and maximum power transfer takes place.

The **STANDING WAVE RATIO** is the measurement of maximum voltage (current) to minimum voltage (current) on a transmission line and measures the perfection of the termination of the line. A ratio of 1:1 describes a line terminated in its characteristic impedance.

ANSWERS TO QUESTIONS Q1. THROUGH Q30.

- A1. *Transmission line.*
- A2. *Input end, generator end, transmitter end, sending end, and source.*
- A3. *Output end, receiving end, load end and sink.*
- A4. *Parallel two-wire, twisted pair, shielded pair, coaxial line and waveguide.*
- A5. *Power lines, rural telephone lines, and telegraph lines.*
- A6. *High radiation losses and noise pickup.*
- A7. *Twin lead.*
- A8. *The conductors are balanced to ground.*
- A9. *Air coaxial (rigid) and solid coaxial (flexible).*
- A10. *The ability to minimize radiation losses.*
- A11. *Expensive to construct, must be kept dry, and high frequency losses limit the practical length of the line.*
- A12. *Cylindrical and rectangular.*
- A13. *Copper, dielectric, and radiation.*
- A14. *Copper losses.*
- A15. *Dielectric losses.*
- A16. $\lambda = 20$ meters.
- A17. *(1) Type of line used, (2) dielectric in the line, and (3) length of line.*
- A18. *Inductance is expressed in microhenrys per unit length, capacitance is expressed in picofarads per unit length, and resistance is expressed in ohms per unit length.*
- A19. *The small amount of current that flows through the dielectric between two wires of a transmission line and is expressed in micromhos per unit length.*
- A20. *When the characteristic impedance of the transmission line and the load impedance are equal.*
- A21. Z_0 and it is the ratio of E to I at every point along the line.
- A22. *Between 50 and 600 ohms.*
- A23. *Incident waves from generator to load. Reflected waves from load back to generator.*
- A24. *2 and 6 have zero resultant wave and they indicate that the incident and reflected waves are 180 degrees out of phase at all parts.*
- A25. *One-fourth the distance from each end of the line.*

- A26. *The load impedance of such a line is equal to Z_0 .*
- A27. *Even quarter-wave points ($1/2\lambda$, 1λ , $3/2\lambda$, etc.).*
- A28. *At $1/2$ wavelength from the end and at every $1/2$ wavelength along the line.*
- A29. *Power standing-wave ratio (pswr).*
- A30. *The existence of voltage variations on a line.*

CHAPTER 4

ANTENNAS

LEARNING OBJECTIVES

Upon completion of this chapter you will be able to:

1. State the basic principles of antenna radiation and list the parts of an antenna.
2. Explain current and voltage distribution on an antenna.
3. Describe how electromagnetic energy is radiated from an antenna.
4. Explain polarization, gain, and radiation resistance characteristics of an antenna.
5. Describe the theory of operation of half-wave and quarter-wave antennas.
6. List the various array antennas.
7. Describe the directional array antennas presented and explain the basic operation of each.
8. Identify various special antennas presented, such as long-wire, V, rhombic, turnstile, ground-plane, and corner-reflector; describe the operation of each.
9. List safety precautions when working aloft and around antennas.

INTRODUCTION

If you had been around in the early days of electronics, you would have considered an ANTENNA (AERIAL) to be little more than a piece of wire strung between two trees or upright poles. In those days, technicians assumed that longer antennas automatically provided better reception than shorter antennas. They also believed that a mysterious MEDIUM filled all space, and that an antenna used this medium to send and receive its energy. These two assumptions have since been discarded. Modern antennas have evolved to the point that highly directional, specially designed antennas are used to relay worldwide communications in space through the use of satellites and Earth station antennas (fig. 4-1). Present transmission theories are based on the assumption that space itself is the only medium necessary to propagate (transmit) radio energy.

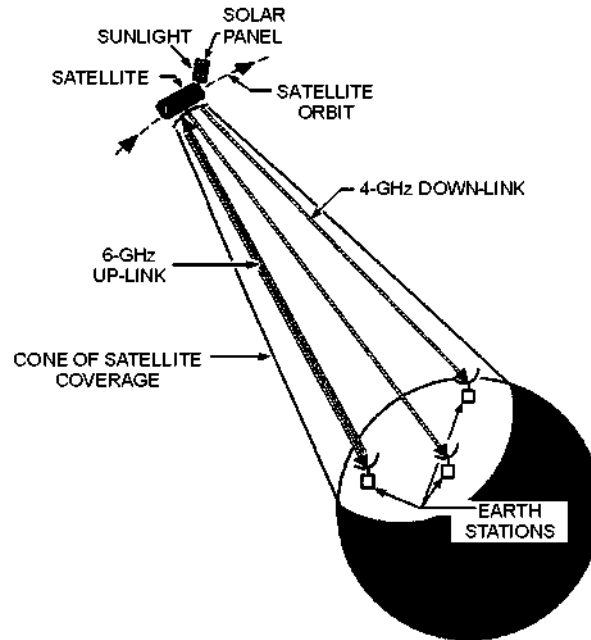

Figure 4-1.—Satellite/earth station communications system.

A tremendous amount of knowledge and information has been gained about the design of antennas and radio-wave propagation. Still, many old-time technicians will tell you that when it comes to designing the length of an antenna, the best procedure is to perform all calculations and try out the antenna. If it doesn't work right, use a cut-and-try method until it does. Fortunately, enough information has been collected over the last few decades that it is now possible to predict the behavior of antennas. This chapter will discuss and explain the basic design and operation of antennas.

PRINCIPLES OF ANTENNA RADIATION

After an rf signal has been generated in a transmitter, some means must be used to radiate this signal through space to a receiver. The device that does this job is the antenna. The transmitter signal energy is sent into space by a TRANSMITTING ANTENNA; the rf signal is then picked up from space by a RECEIVING ANTENNA.

The rf energy is transmitted into space in the form of an electromagnetic field. As the traveling electromagnetic field arrives at the receiving antenna, a voltage is induced into the antenna (a conductor). The rf voltages induced into the receiving antenna are then passed into the receiver and converted back into the transmitted rf information.

The design of the antenna system is very important in a transmitting station. The antenna must be able to radiate efficiently so the power supplied by the transmitter is not wasted. An efficient transmitting antenna must have exact dimensions. The dimensions are determined by the transmitting frequencies. The dimensions of the receiving antenna are not critical for relatively low radio frequencies. However, as the frequency of the signal being received increases, the design and installation of the receiving antenna become more critical. An example of this is a television receiving antenna. If you raise it a few more inches from the ground or give a slight turn in direction, you can change a snowy blur into a clear picture.

The conventional antenna is a conductor, or system of conductors, that radiates or intercepts electromagnetic wave energy. An ideal antenna has a definite length and a uniform diameter, and is completely isolated in space. However, this ideal antenna is not realistic. Many factors make the design of an antenna for a communications system a more complex problem than you would expect. These factors include the height of the radiator above the earth, the conductivity of the earth below it, and the shape and dimensions of the antenna. All of these factors affect the radiated-field pattern of the antenna in space. Another problem in antenna design is that the radiation pattern of the antenna must be directed between certain angles in a horizontal or vertical plane, or both.

Most practical transmitting antennas are divided into two basic classifications, HERTZ (half-wave) ANTENNAS and MARCONI (quarter-wave) ANTENNAS. Hertz antennas are generally installed some distance above the ground and are positioned to radiate either vertically or horizontally. Marconi antennas operate with one end grounded and are mounted perpendicular to the Earth or to a surface acting as a ground. Hertz antennas are generally used for frequencies above 2 megahertz. Marconi antennas are used for frequencies below 2 megahertz and may be used at higher frequencies in certain applications.

A complete antenna system consists of three parts: (1) The COUPLING DEVICE, (2) the FEEDER, and (3) the ANTENNA, as shown in figure 4-2. The coupling device (coupling coil) connects the transmitter to the feeder. The feeder is a transmission line that carries energy to the antenna. The antenna radiates this energy into space.

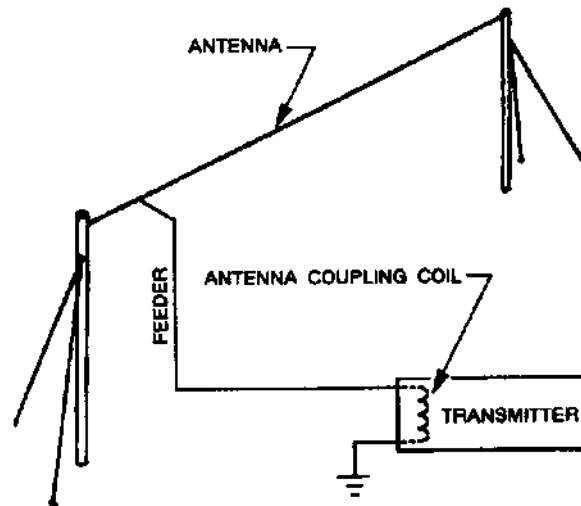

Figure 4-2.—Typical antenna system.

The factors that determine the type, size, and shape of the antenna are (1) the frequency of operation of the transmitter, (2) the amount of power to be radiated, and (3) the general direction of the receiving set. Typical antennas are shown in figure 4-3.

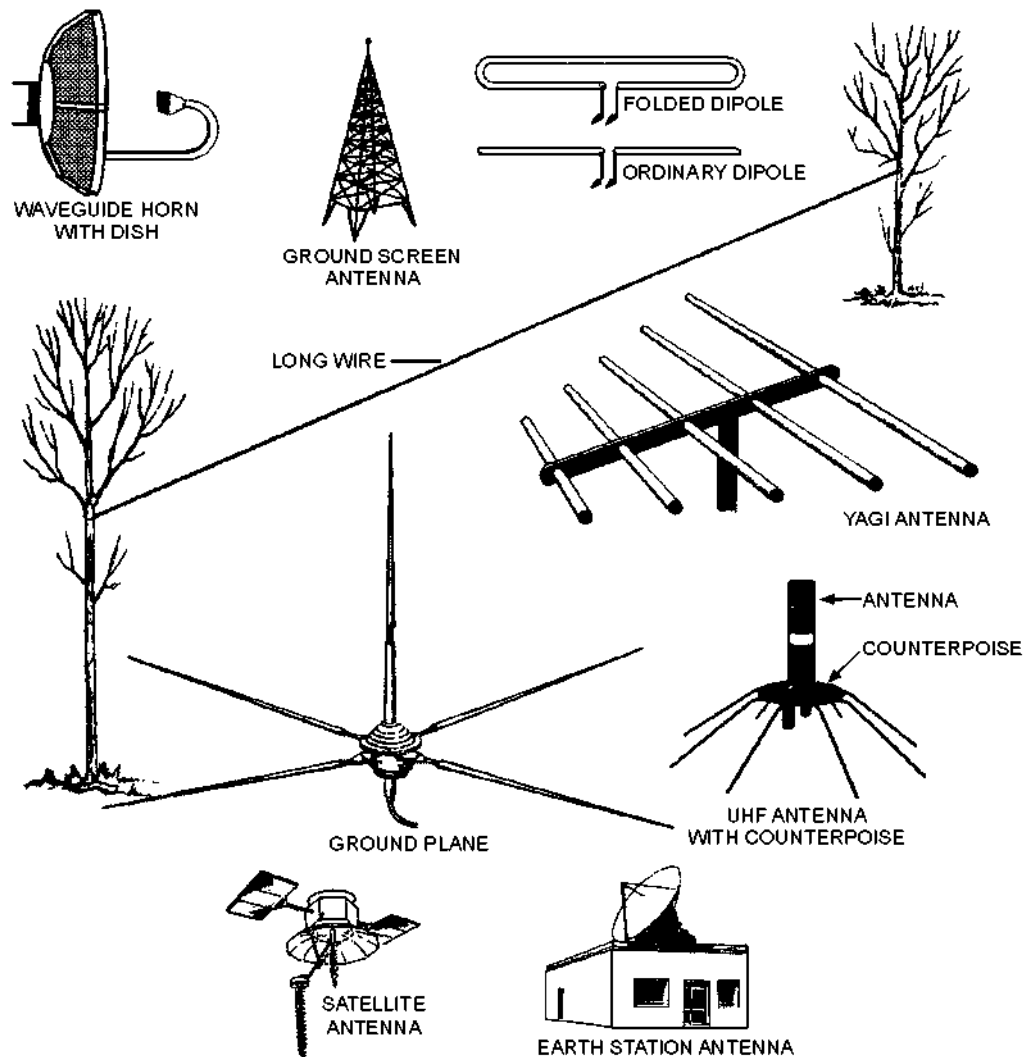

Figure 4-3.—Typical antennas.

CURRENT AND VOLTAGE DISTRIBUTION ON AN ANTENNA

A current flowing in a wire whose length is properly related to the rf produces an electro magnetic field. This field is radiated from the wire and is set free in space. We will discuss how these waves are set free later in this chapter. Remember, the principles of radiation of electromagnetic energy are based on two laws:

1. A MOVING ELECTRIC FIELD CREATES A MAGNETIC (H) FIELD.
2. A MOVING MAGNETIC FIELD CREATES AN ELECTRIC (E) FIELD.

In space, these two fields will be in phase and perpendicular to each other at any given time. Although a conductor is usually considered present when a moving electric or magnetic field is mentioned, the laws that govern these fields say nothing about a conductor. Therefore, these laws hold true whether a conductor is present or not.

Figure 4-4 shows the current and voltage distribution on a half-wave (Hertz) antenna. In view A, a piece of wire is cut in half and attached to the terminals of a high-frequency ac generator. The frequency of the generator is set so that each half of the wire is 1/4 wavelength of the output. The result is a common type of antenna known as a DIPOLE.

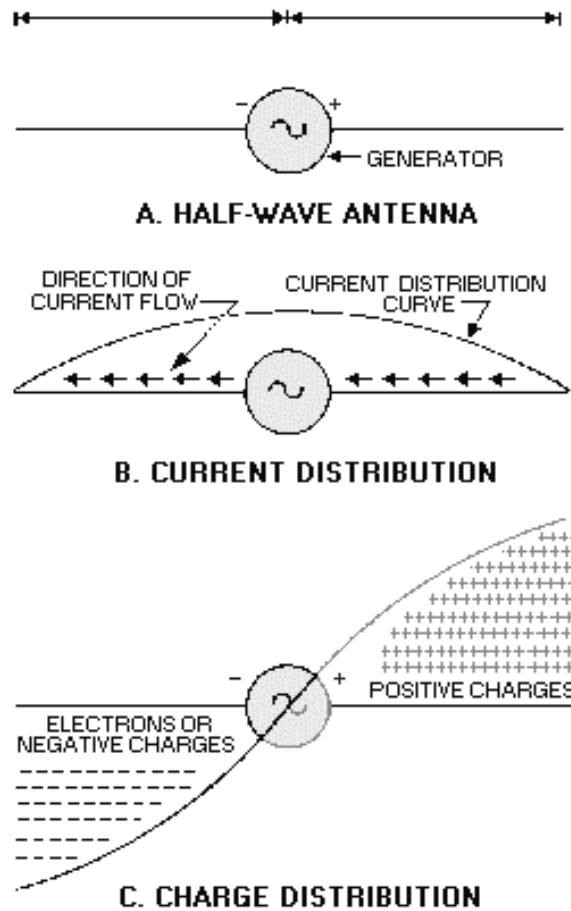

Figure 4-4.—Current and voltage distribution on an antenna.

At a given time the right side of the generator is positive and the left side negative. Remember that like charges repel. Because of this, electrons will flow away from the negative terminal as far as possible, but will be attracted to the positive terminal. View B shows the direction and distribution of electron flow. The distribution curve shows that most current flows in the center and none flows at the ends. The current distribution over the antenna will always be the same no matter how much or how little current is flowing. However, current at any given point on the antenna will vary directly with the amount of voltage developed by the generator.

One-quarter cycle after electrons have begun to flow, the generator will develop its maximum voltage and the current will decrease to 0. At that time the condition shown in view C will exist. No current will be flowing, but a maximum number of electrons will be at the left end of the line and a minimum number at the right end. The charge distribution view C along the wire will vary as the voltage of the generator varies. Therefore, you may draw the following conclusions:

1. A current flows in the antenna with an amplitude that varies with the generator voltage.
2. A sinusoidal distribution of charge exists on the antenna. Every 1/2 cycle, the charges reverse polarity.
3. The sinusoidal variation in charge magnitude lags the sinusoidal variation in current by 1/4 cycle.

Q1. What are the two basic classifications of antennas?

Q2. What are the three parts of a complete antenna system?

Q3. What three factors determine the type, size, and shape of an antenna?

RADIATION OF ELECTROMAGNETIC ENERGY

The electromagnetic radiation from an antenna is made up of two components, the E field and the H field. We discussed these fields in chapters 1 and 2. The two fields occur 90 degrees out of phase with each other. These fields add and produce a single electromagnetic field. The total energy in the radiated wave remains constant in space except for some absorption of energy by the Earth. However, as the wave advances, the energy spreads out over a greater area and, at any given point, decreases as the distance increases.

Various factors in the antenna circuit affect the radiation of these waves. In figure 4-5, for example, if an alternating current is applied at the A end of the length of wire from A to B, the wave will travel along the wire until it reaches the B end. Since the B end is free, an open circuit exists and the wave cannot travel farther. This is a point of high impedance. The wave bounces back (reflects) from this point of high impedance and travels toward the starting point, where it is again reflected. The energy of the wave would be gradually dissipated by the resistance of the wire of this back-and-forth motion (oscillation); however, each time it reaches the starting point, the wave is reinforced by an amount sufficient to replace the energy lost. This results in continuous oscillations of energy along the wire and a high voltage at the A end of the wire. These oscillations are applied to the antenna at a rate equal to the frequency of the rf voltage.

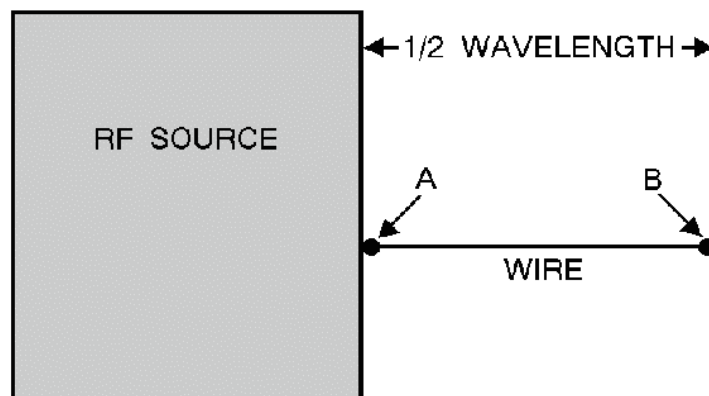

Figure 4-5.—Antenna and rf source.

These impulses must be properly timed to sustain oscillations in the antenna. The rate at which the waves travel along the wire is constant at approximately 300,000,000 meters per second. The length of

the antenna must be such that a wave will travel from one end to the other and back again during the period of 1 cycle of the rf voltage. Remember, the distance a wave travels during the period of 1 cycle is known as the wavelength and is found by dividing the rate of travel by the frequency.

Look at the current and voltage (charge) distribution on the antenna in figure 4-6. A maximum movement of electrons is in the center of the antenna at all times; therefore, the center of the antenna is at a low impedance. This condition is called a STANDING WAVE of current. The points of high current and high voltage are known as current and voltage LOOPS. The points of minimum current and minimum voltage are known as current and voltage NODES. View A shows a current loop and current nodes. View B shows voltage loops and a voltage node. View C shows the resultant voltage and current loops and nodes. The presence of standing waves describes the condition of resonance in an antenna. At resonance the waves travel back and forth in the antenna reinforcing each other and the electromagnetic waves are transmitted into space at maximum radiation. When the antenna is not at resonance, the waves tend to cancel each other and lose energy in the form of heat.

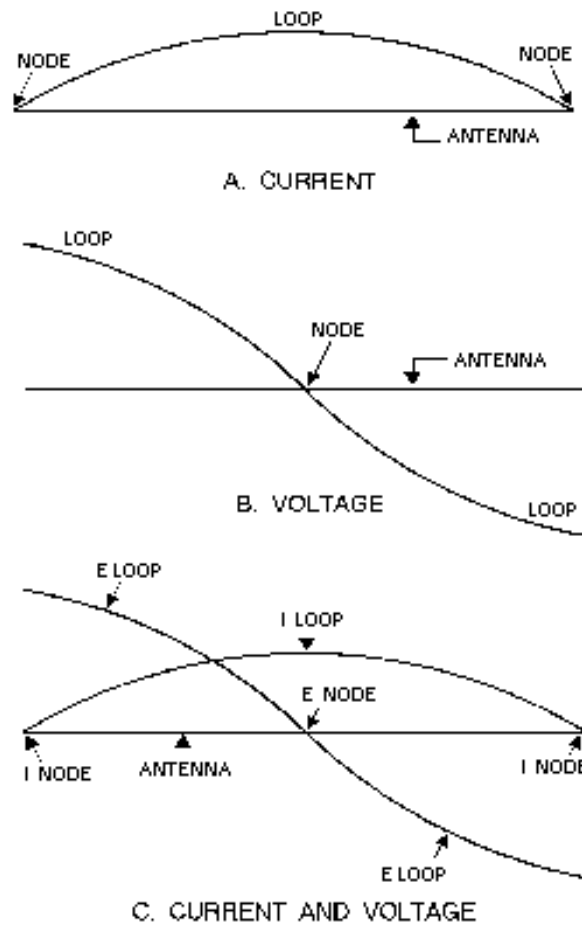

Figure 4-6.—Standing waves of voltage and current on an antenna.

Q4. If a wave travels exactly the length of an antenna from one end to the other and back during the period of 1 cycle, what is the length of the antenna?

Q5. What is the term used to identify the points of high current and high voltage on an antenna?

Q6. What is the term used to identify the points of minimum current and minimum voltage on an antenna?

ANTENNA CHARACTERISTICS

You can define an antenna as a conductor or group of conductors used either for radiating electromagnetic energy into space or for collecting it from space. Electrical energy from the transmitter is converted into electromagnetic energy by the antenna and radiated into space. On the receiving end, electromagnetic energy is converted into electrical energy by the antenna and is fed into the receiver.

Fortunately, separate antennas seldom are required for both transmitting and receiving rf energy. Any antenna can transfer energy from space to its input receiver with the same efficiency that it transfers energy from the transmitter into space. Of course, this is assuming that the same frequency is used in both cases. This property of interchangeability of the same antenna for transmitting and receiving is known as antenna RECIPROCITY. Antenna reciprocity is possible because antenna characteristics are essentially the same for sending and receiving electromagnetic energy.

RECIPROCITY OF ANTENNAS

In general, the various properties of an antenna apply equally, regardless of whether you use the antenna for transmitting or receiving. The more efficient a certain antenna is for transmitting, the more efficient it will be for receiving on the same frequency. Likewise, the directive properties of a given antenna also will be the same whether it is used for transmitting or receiving.

Assume, for example, that a certain antenna used with a transmitter radiates a maximum amount of energy at right angles to the axis of the antenna, as shown in figure 4-7, view A. Note the minimum amount of radiation along the axis of the antenna. Now, if this same antenna were used as a receiving antenna, as shown in view B, it would receive best in the same directions in which it produced maximum radiation; that is, at right angles to the axis of the antenna.

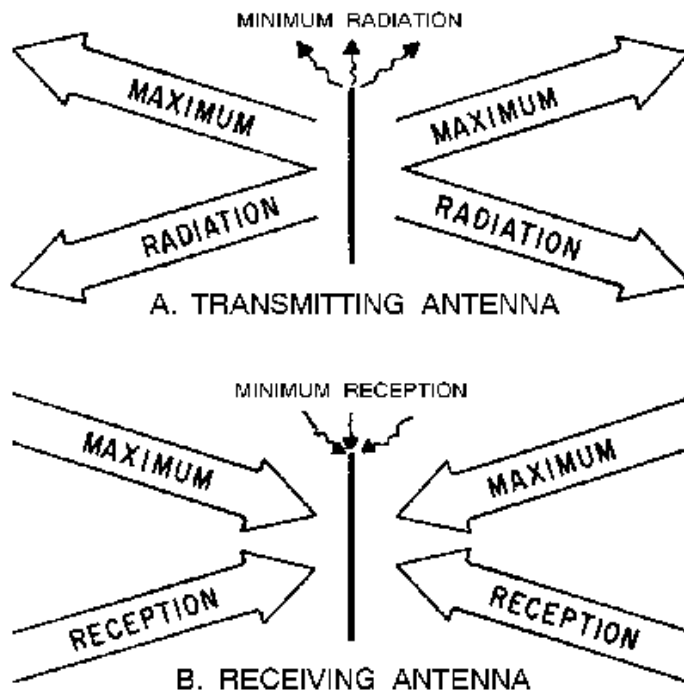

Figure 4-7.—Reciprocity of antennas.

ANTENNA GAIN

Another characteristic of a given antenna that remains the same whether the antenna is used for transmitting or receiving is GAIN. Some antennas are highly directional that is, more energy is propagated in certain directions than in others. The ratio between the amount of energy propagated in these directions compared to the energy that would be propagated if the antenna were not directional is known as its gain. When a transmitting antenna with a certain gain is used as a receiving antenna, it will also have the same gain for receiving.

POLARIZATION

Let's review polarization briefly. In chapter 2 you learned that the radiation field is composed of electric and magnetic lines of force. These lines of force are always at right angles to each other. Their intensities rise and fall together, reaching their maximums 90 degrees apart. The electric field determines the direction of polarization of the wave. In a vertically polarized wave, the electric lines of force lie in a vertical direction. In a horizontally polarized wave, the electric lines of force lie in a horizontal direction. Circular polarization has the electric lines of force rotating through 360 degrees with every cycle of rf energy.

The electric field was chosen as the reference field because the intensity of the wave is usually measured in terms of the electric field intensity (volts, millivolts, or microvolts per meter). When a single-wire antenna is used to extract energy from a passing radio wave, maximum pickup will result when the antenna is oriented in the same direction as the electric field. Thus a vertical antenna is used for the efficient reception of vertically polarized waves, and a horizontal antenna is used for the reception of horizontally polarized waves. In some cases the orientation of the electric field does not remain constant.

Instead, the field rotates as the wave travels through space. Under these conditions both horizontal and vertical components of the field exist and the wave is said to have an elliptical polarization.

Q7. The various properties of a transmitting antenna can apply equally to the same antenna when it is used as a receiving antenna. What term is used for this property?

Q8. The direction of what field is used to designate the polarization of a wave?

Q9. If a wave's electric lines of force rotate through 360 degrees with every cycle of rf energy, what is the polarization of this wave?

Polarization Requirements for Various Frequencies

Ground-wave transmission is widely used at medium and low frequencies. Horizontal polarization cannot be used at these frequencies because the electric lines of force are parallel to and touch the earth. Since the earth acts as a fairly good conductor at low frequencies, it would short out the horizontal electric lines of force and prevent the radio wave from traveling very far. Vertical electric lines of force, on the other hand, are bothered very little by the earth. Therefore vertical polarization is used for ground-wave transmission, allowing the radio wave to travel a considerable distance along the ground surface with minimum attenuation.

Sky-wave transmission is used at high frequencies. Either horizontal or vertical polarization can be used with sky-wave transmission because the sky wave arrives at the receiving antenna elliptically polarized. This is the result of the wave traveling obliquely through the Earth's magnetic field and striking the ionosphere. The radio wave is given a twisting motion as it strikes the ionosphere. Its orientation continues to change because of the unstable nature of the ionosphere. The relative amplitudes and phase differences between the horizontal and vertical components of the received wave also change. Therefore, the transmitting and receiving antennas can be mounted either horizontally or vertically.

Although either horizontally or vertically polarized antennas can be used for high frequencies, horizontally polarized antennas have certain advantages and are therefore preferred. One advantage is that vertically polarized interference signals, such as those produced by automobile ignition systems and electrical appliances, are minimized by horizontal polarization. Also, less absorption of radiated energy by buildings or wiring occurs when these antennas are used. Another advantage is that support structures for these antennas are of more convenient size than those for vertically polarized antennas.

For frequencies in the vhf or uhf range, either horizontal or vertical polarization is satisfactory. These radio waves travel directly from the transmitting antenna to the receiving antenna without entering the ionosphere. The original polarization produced at the transmitting antenna is maintained throughout the entire travel of the wave to the receiver. Therefore, if a horizontally polarized antenna is used for transmitting, a horizontally polarized antenna must be used for receiving. The requirements would be the same for a vertical transmitting and receiving antenna system.

For satellite communications, parallel frequencies can be used without interference by using polarized radiation. The system setup is shown in figure 4-8. One pair of satellite antennas is vertically polarized and another pair is horizontally polarized. Either vertically or horizontally polarized transmissions are received by the respective antenna and retransmitted in the same polarization. For example, transmissions may be made in the 3.7 to 3.74 GHz range on the vertical polarization path and in the 3.72 to 3.76 GHz range on the horizontal polarization path without adjacent frequency (co-channel) interference.

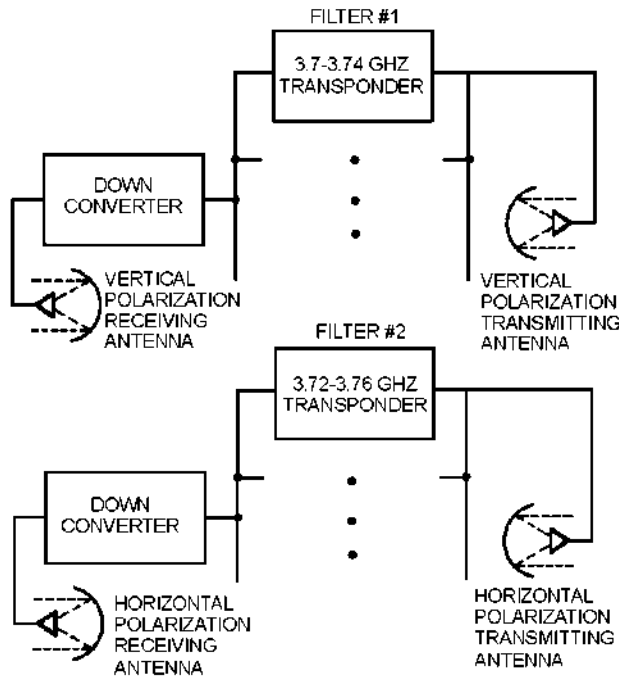

Figure 4-8.—Satellite transmissions using polarized radiation.

Advantages of Vertical Polarization

Simple vertical antennas can be used to provide OMNIDIRECTIONAL (all directions) communication. This is an advantage when communications must take place from a moving vehicle.

In some overland communications, such as in vehicular installations, antenna heights are limited to 3 meters (10 feet) or less. In such instances vertical polarization results in a stronger receiver signal than does horizontal polarization at frequencies up to about 50 megahertz. From approximately 50 to 100 megahertz, vertical polarization results in a slightly stronger signal than does horizontal polarization with antennas at the same height. Above 100 megahertz, the difference in signal strength is negligible.

For transmission over bodies of water, vertical polarization is much better than horizontal polarization for antennas at the lower heights. As the frequency increases, the minimum antenna height decreases. At 30 megahertz, vertical polarization is better for antenna heights below about 91 meters (300 feet); at 85 megahertz, antenna heights below 15 meters (50 feet); and still lower heights at the high frequencies. Therefore, at ordinary antenna mast heights of 12 meters (40 feet), vertical polarization is advantageous for frequencies less than about 100 megahertz.

Radiation is somewhat less affected by reflections from aircraft flying over the transmission path when vertical polarization is used instead of horizontal polarization. With horizontal polarization, such reflections cause variations in received signal strength. This factor is important in locations where aircraft traffic is heavy.

When vertical polarization is used, less interference is produced or picked up because of strong vhf and uhf broadcast transmissions (television and fm). This is because vhf and uhf transmissions use horizontal polarization. This factor is important when an antenna must be located in an urban area having several television and fm broadcast stations.

Advantages of Horizontal Polarization

A simple horizontal antenna is bi-directional. This characteristic is useful when you desire to minimize interference from certain directions. Horizontal antennas are less likely to pick up man-made interference, which ordinarily is vertically polarized.

When antennas are located near dense forests or among buildings, horizontally polarized waves suffer lower losses than vertically polarized waves, especially above 100 megahertz. Small changes in antenna locations do not cause large variations in the field intensity of horizontally polarized waves. When vertical polarization is used, a change of only a few meters in the antenna location may have a considerable effect on the received signal strength. This is the result of interference patterns that produce standing waves in space when spurious reflections from trees or buildings occur.

When simple antennas are used, the transmission line, which is usually vertical, is less affected by a horizontally mounted antenna. When the antenna is mounted at right angles to the transmission line and horizontal polarization is used, the line is kept out of the direct field of the antenna. As a result, the radiation pattern and electrical characteristics of the antenna are practically unaffected by the presence of the vertical transmission line.

Q10. What type of polarization should be used at medium and low frequencies?

Q11. What is an advantage of using horizontal polarization at high frequencies?

Q12. What type of polarization should be used if an antenna is mounted on a moving vehicle at frequencies below 50 megahertz?

RADIATION RESISTANCE

Radiated energy is the useful part of the transmitter's signal. However, it represents as much of a loss to the antenna as the energy lost in heating the antenna wire. In either case, the dissipated power is equal to I^2R . In the case of heat losses, the R is real resistance. In the case of radiation, R is an assumed resistance; if this resistance were actually present, it would dissipate the same amount of power that the antenna takes to radiate the energy. This assumed resistance is referred to as the RADIATION RESISTANCE.

Radiation resistance varies at different points on the antenna. This resistance is always measured at a current loop. For the antenna in free space, that is, entirely removed from any objects that might affect its operation, the radiation resistance is 73 ohms. A practical antenna located over a ground plane may have any value of radiation resistance from 0 to approximately 100 ohms. The exact value of radiation resistance depends on the height of the antenna above the ground. For most half-wave wire antennas, the radiation resistance is about 65 ohms. It will usually vary between 55 and 600 ohms for antennas constructed of rod or tubing. The actual value of radiation resistance, so long as it is 50 ohms or more, has little effect on the radiation efficiency of the antenna. This is because the ohmic resistance is about 1 ohm for conductors of large diameter. The ohmic resistance does not become important until the radiation resistance drops to a value less than 10 ohms. This may be the case when several antennas are coupled together.

RADIATION TYPES AND PATTERNS

The energy radiated from an antenna forms a field having a definite RADIATION PATTERN. A radiation pattern is a plot of the radiated energy from an antenna. This energy is measured at various angles at a constant distance from the antenna. The shape of this pattern depends on the type of antenna

used. In this section, we will introduce the basic types of radiation (isotropic and anisotropic) and their radiation patterns.

Isotropic Radiation

Some antenna sources radiate energy equally in all directions. Radiation of this type is known as ISOTROPIC RADIATION. We all know the Sun radiates energy in all directions. The energy radiated from the Sun measured at any fixed distance and from any angle will be approximately the same. Assume that a measuring device is moved around the Sun and stopped at the points indicated in figure 4-9 to make a measurement of the amount of radiation. At any point around the circle, the distance from the measuring device to the Sun is the same. The measured radiation will also be the same. The Sun is therefore considered an isotropic radiator.

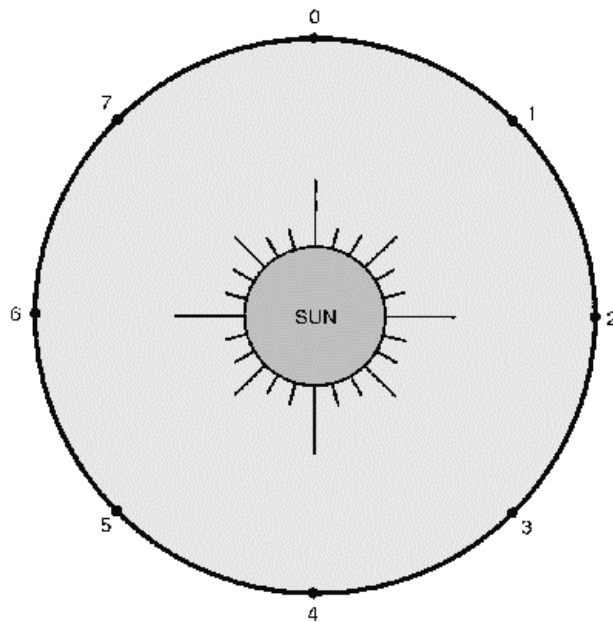

Figure 4-9.—Isotropic radiator.

To plot this pattern, we will assume that the radiation is measured on a scale of 0 to 10 units and that the measured amount of radiation is 7 units at all points. We will then plot our measurements on two different types of graphs, rectangular- and polar-coordinate graphs. The RECTANGULAR-COORDINATE GRAPH of the measured radiation, shown in view A of figure 4-10, is a straight line plotted against positions along the circle. View B shows the POLAR-COORDINATE GRAPH for the same isotropic source.

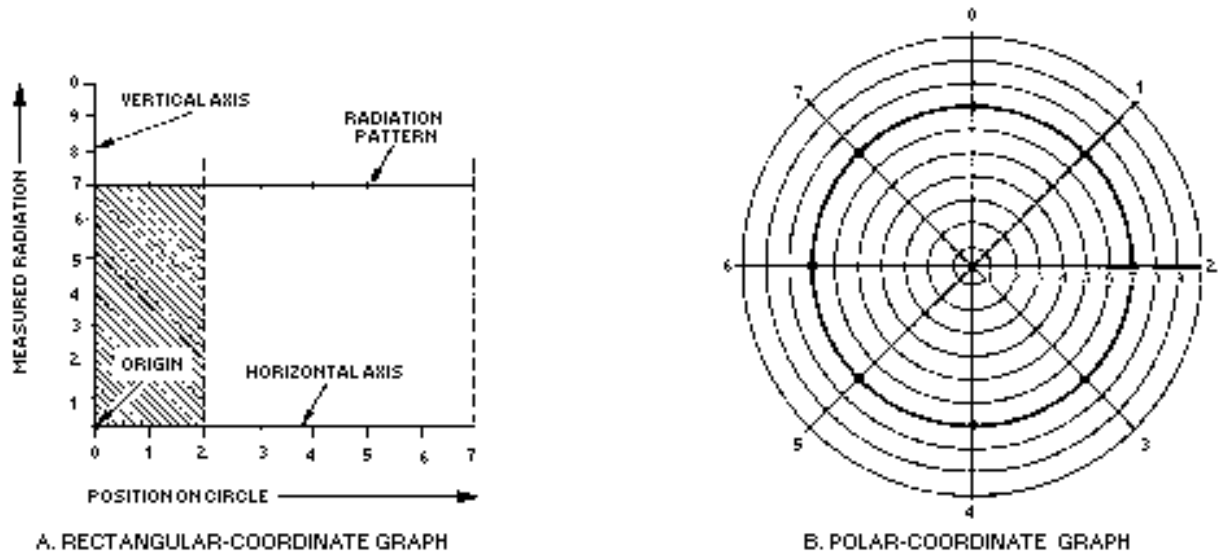

Figure 4-10.—Comparison of rectangular- and polar-coordinate graphs for an isotropic source.

In the rectangular-coordinate graph, points are located by projection from a pair of stationary, perpendicular axes. In the polar-coordinate graph, points are located by projection along a rotating axis (radius) to an intersection with one of several concentric, equally-spaced circles. The horizontal axis on the rectangular-coordinate graph corresponds to the circles on the polar-coordinate graph. The vertical axis on the rectangular-coordinate graph corresponds to the rotating axis (radius) on the polar-coordinate graph.

Rectangular-Coordinate Pattern

Look at view A of figure 4-10. The numbered positions around the circle are laid out on the HORIZONTAL AXIS of the graph from 0 to 7 units. The measured radiation is laid out on the VERTICAL AXIS of the graph from 0 to 10 units. The units on both axes are chosen so the pattern occupies a convenient part of the graph.

The horizontal and vertical axes are at a right angle to each other. The point where the axes cross each other is known as the ORIGIN. In this case, the origin is 0 on both axes. Now, assume that a radiation value of 7 units view B is measured at position 2. From position 2 on the horizontal axis, a dotted line is projected upwards that runs parallel to the vertical axis. From position 7 on the vertical axis, a line is projected to the right that runs parallel to the horizontal axis. The point where the two lines cross (INTERCEPT) represents a value of 7 radiation units at position 2. This is the only point on the graph that can represent this value.

As you can see from the figure, the lines used to plot the point form a rectangle. For this reason, this type of plot is called a *rectangular-coordinate graph*. A new rectangle is formed for each different point plotted. In this example, the points plotted lie in a straight line extending from 7 units on the vertical scale to the projection of position 7 on the horizontal scale. This is the characteristic pattern in rectangular coordinates of an isotropic source of radiation.

Polar-Coordinate Pattern

The polar-coordinate graph has proved to be of great use in studying radiation patterns. Compare views A and B of figure 4-10. Note the great difference in the shape of the radiation pattern when it is

transferred from the rectangular-coordinate graph in view A to the polar-coordinate graph in view B. The scale of radiation values used in both graphs is identical, and the measurements taken are both the same. However, the shape of the pattern is drastically different.

Look at view B of figure 4-10 and assume that the center of the concentric circles is the Sun. Assume that a radius is drawn from the Sun (center of the circle) to position 0 of the circle. When you move to position 1, the radius moves to position 1; when you move to position 2, the radius also moves to position 2, and so on.

The positions where a measurement was taken are marked as 0 through 7 on the graph. Note how the position of the radius indicates the actual direction from the source at which the measurement was taken. This is a distinct advantage over the rectangular-coordinate graph in which the position is indicated along a straight-line axis and has no physical relation to the actual direction of measurement. Now that we have a way to indicate the *direction* of measurement, we must devise a way to indicate the *magnitude* of the radiation.

Notice that the rotating axis is always drawn from the center of the graph to some position on the edge of the graph. As the axis moves toward the edge of the graph, it passes through a set of equally-spaced, concentric circles. In this example view B, they are numbered successively from 1 to 10 from the center out. These circles are used to indicate the magnitude of the radiation.

The advantages of the polar-coordinate graph are immediately evident. The source, which is at the center of the observation circles, is also at the center of the graph. By looking at a polar-coordinate plot of a radiation pattern, you can immediately see the direction and strength of radiation put out by the source. Therefore, the polar-coordinate graph is more useful than the rectangular-coordinate graph in plotting radiation patterns.

Anisotropic Radiation

Most radiators emit (radiate) stronger radiation in one direction than in another. A radiator such as this is referred to as ANISOTROPIC. An example of an anisotropic radiator is an ordinary flashlight. The beam of the flashlight lights only a portion of the space surrounding it. If a circle is drawn with the flashlight as the center, as shown in view B of figure 4-11, the radiated light can be measured at different positions around the circle. Again, as with the isotropic radiator, all positions are the same distance from the center, but at different angles. However, in this illustration the radiated light is measured at 16 different positions on the circle.

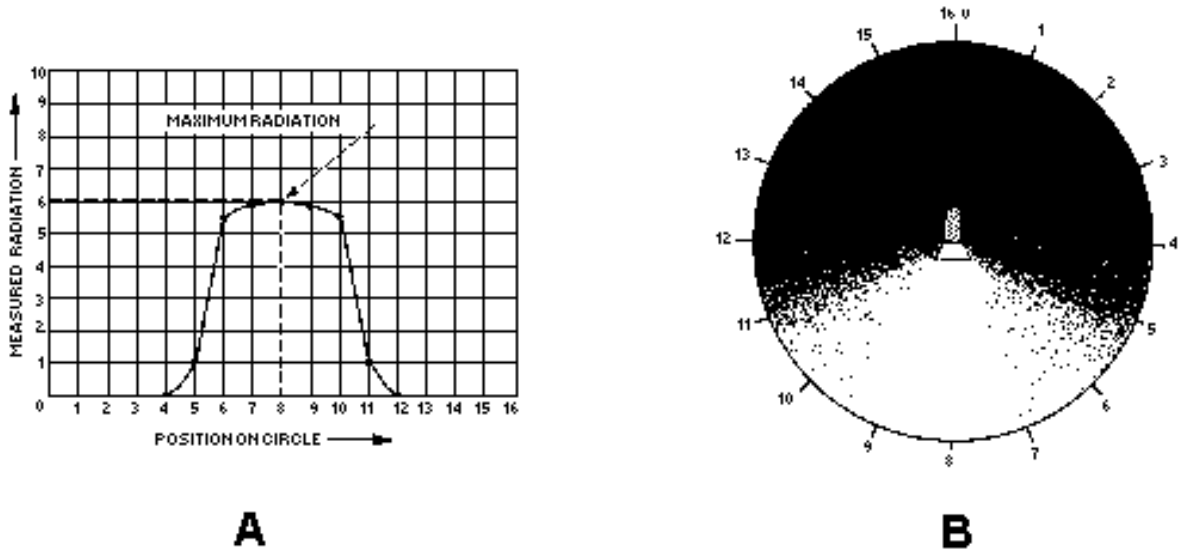

Figure 4-11.—Anisotropic radiator.

Directly behind the flashlight (position 0) the radiation measured is minimum. Accordingly, a 0 value is assigned to this position in the rectangular-coordinate graph (fig. 4-11, view A). This radiation remains at minimum until position 4 is reached. Between positions 4 and 6, the measuring device enters the flashlight beam. You can see this transition from darkness to brightness easily in view B. Radiation is fairly constant between positions 6 and 10. Maximum brightness occurs at position 8, which is directly in the path of the flashlight beam. From positions 10 to 12, the measuring device leaves the flashlight beam and the radiation measurement falls off sharply. At position 13 the radiation is again at 0 and stays at this value back to position 0.

Radiation from a light source and radiation from an antenna are both forms of electromagnetic waves. Therefore, the measurement of radiation of an antenna follows the same basic procedure as that just described for the Sun and the flashlight. Before proceeding further with the study of antenna patterns, you should be sure you understand the methods used to graph the measured radiation (magnitude of the radiation). Study the rectangular- and polar-coordinate systems of plotting presented in the following section.

- Q13. *What is the radiation resistance of a half-wave antenna in free space?*
- Q14. *A radiating source that radiates energy stronger in one direction than another is known as what type of radiator?*
- Q15. *A radiating source that radiates energy equally in all directions is known as what type of radiator?*
- Q16. *A flashlight is an example of what type of radiator?*

In figure 4-11, view A, the radiation pattern of the flashlight is graphed in rectangular coordinates. The illustration of the flashlight beam in view B clearly indicates the shape of the flashlight beam. This is not evident in the radiation pattern plotted on the rectangular-coordinate graph. Now look at figure 4-12. The radiation pattern shown in this figure looks very much like the actual flashlight beam. The pattern in figure 4-12 is plotted using the same values as those of figure 4-11, view A, but is drawn using polar coordinates.

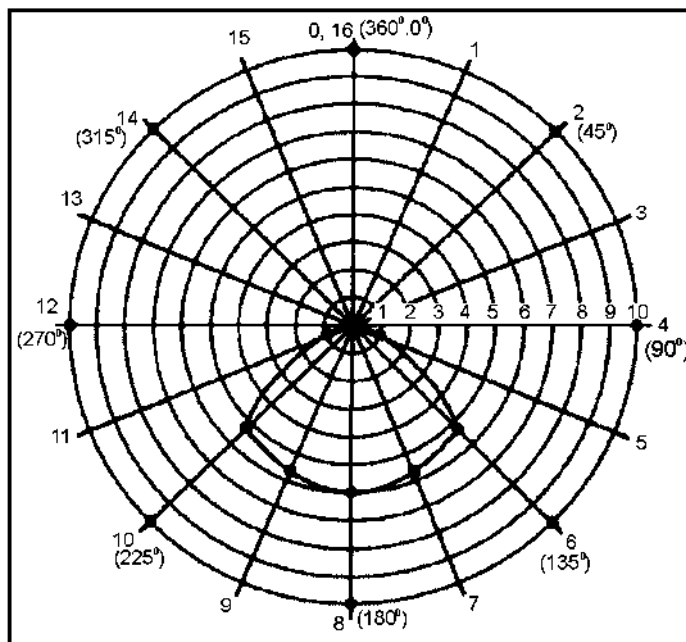

Figure 4-12.—Polar-coordinate graph for anisotropic radiator.

The positions marked off on the two polar-coordinate graphs in figures 4-10 and 4-12 were selected and numbered arbitrarily. However, a standard method allows the positions around a source to be marked off so that one radiation pattern can easily be compared with another. This method is based on the fact that a circle has a radius of 360 degrees. The radius extending vertically from the center (position 0 in figure 4-10) is designated 0 degrees. At position 4 the radius is at a right angle to the 0-degree radius. Accordingly, the radius at position 4 is marked 90 degrees, position 8 is 180 degrees, position 12 is 270 degrees, and position 16 is 360 degrees. The various radii drawn on the graph are all marked according to the angle each radius makes with the reference radius at 0 degrees.

The radiation pattern in figure 4-12 is obtained by using the same procedure that was used for (figure 4-10, view B). The radiation measured at positions 1, 2, 3, and 4 is 0. Position 5 measures approximately 1 unit. This is marked on the graph and the rotating radius moves to position 6. At this position a reading of 5.5 units is taken. As before, this point is marked on the graph. The procedure is repeated around the circle and a reading is obtained from positions 6 through 11. At position 12 no radiation is indicated, and this continues on to position 16.

The polar-coordinate graph now shows a definite area enclosed by the radiation pattern. This pattern indicates the general direction of radiation from the source. The enclosed area is called a LOBE. Outside of this area, minimum radiation is emitted in any direction. For example, at position 2 the radiation is 0. Such a point is called a NULL. In real situations, some radiation is usually transmitted in all directions. Therefore, a null is used to indicate directions of minimum radiation. The pattern of figure 4-12 shows one lobe and one continuous null.

ANTENNA LOADING

You will sometimes want to use one antenna system for transmitting and receiving on several different frequencies. Since the antenna must always be in resonance with the applied frequency, you may need to either physically or electrically lengthen or shorten the antenna.

Except for trailing-wire antennas used in aircraft installations (which may be lengthened or shortened), physically lengthening the antenna is not very practical. But you can achieve the same result by changing the electrical length of the antenna. To change the electrical length, you can insert either an inductor or a capacitor in series with the antenna. This is shown in figure 4-13, views A and B. Changing the electrical length by this method is known as LUMPED-IMPEDANCE TUNING, or LOADING. The electrical length of any antenna wire can be increased or decreased by loading. If the antenna is too short for the wavelength being used, it is resonant at a higher frequency than that at which it is being excited. Therefore, it offers a capacitive reactance at the excitation frequency. This capacitive reactance can be compensated for by introducing a lumped-inductive reactance, as shown in view A. Similarly, if the antenna is too long for the transmitting frequency, it offers an inductive reactance. Inductive reactance can be compensated for by introducing a lumped-capacitive reactance, as shown in view B. An antenna without loading is represented in view C.

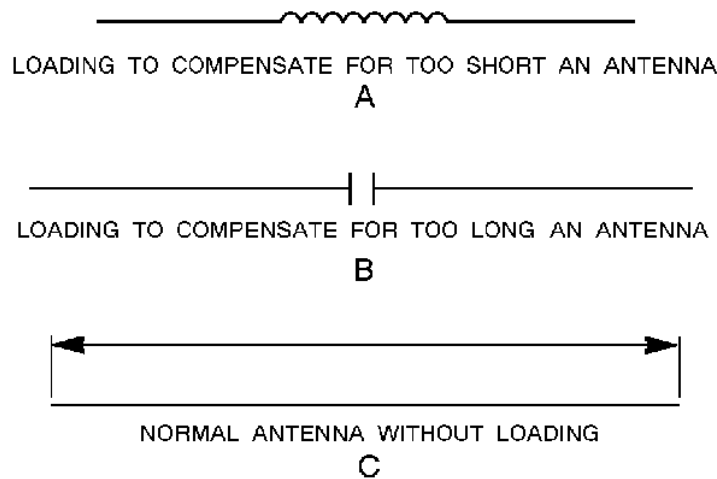

Figure 4-13.—Electrically equal antenna.

BASIC ANTENNAS

Before you look at the various types of antennas, consider the relationship between the wavelength at which the antenna is being operated and the actual length of the antenna. An antenna does not necessarily radiate or receive more energy when it is made longer. Specific dimensions must be used for efficient antenna operation.

Nearly all antennas have been developed from two basic types, the Hertz and the Marconi. The basic Hertz antenna is $1/2$ wavelength long at the operating frequency and is insulated from ground. It is often called a DIPOLE or a DOUBLET. The basic Marconi antenna is $1/4$ wavelength long and is either grounded at one end or connected to a network of wires called a COUNTERPOISE. The ground or counterpoise provides the equivalent of an additional $1/4$ wavelength, which is required for the antenna to resonate.

HALF-WAVE ANTENNAS

A half-wave antenna (referred to as a dipole, Hertz, or doublet) consists of two lengths of wire rod, or tubing, each $1/4$ wavelength long at a certain frequency. It is the basic unit from which many complex antennas are constructed. The half-wave antenna operates independently of ground; therefore, it may be installed far above the surface of the Earth or other absorbing bodies. For a dipole, the current is

maximum at the center and minimum at the ends. Voltage is minimum at the center and maximum at the ends, as was shown in figure 4-6.

Radiation Patterns

In the following discussion, the term DIPOLE is used to mean the basic half-wave antenna. The term DOUBLET is used to indicate an antenna that is very short compared with the wavelength of the operating frequency. Physically, it has the same shape as the dipole.

RADIATION PATTERN OF A DOUBLET.—The doublet is the simplest form of a practical antenna. Its radiation pattern can be plotted like the radiation pattern of the flashlight (fig. 4-12). Figure 4-14 shows the development of vertical and horizontal patterns for a doublet. This is NOT a picture of the radiation, but three-dimensional views of the pattern itself. In three views the pattern resembles a doughnut. From the dimensions in these views, two types of polar-coordinate patterns can be drawn, horizontal and vertical. The HORIZONTAL PATTERN view A is derived from the solid pattern view C by slicing it horizontally. This produces view B, which is converted to the polar coordinates seen in view A. The horizontal pattern illustrates that the radiation is constant in any direction along the horizontal plane.

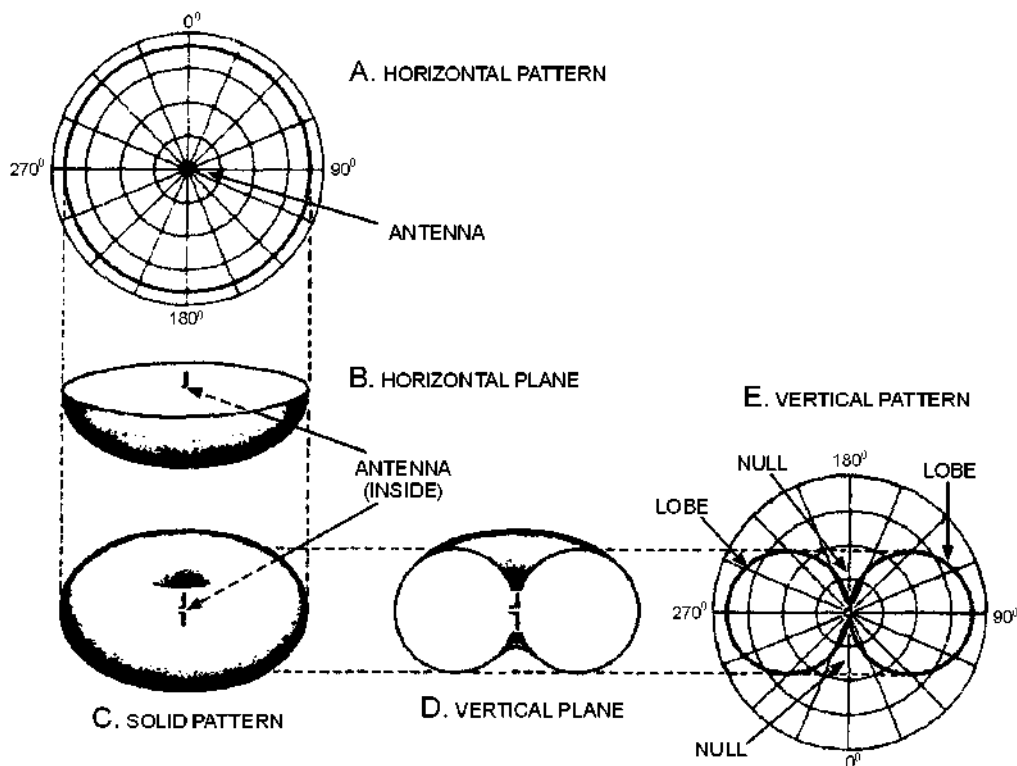

Figure 4-14.—Development of vertical and horizontal patterns.

A VERTICAL PATTERN view E is obtained from the drawing of the vertical plane view D of the radiation pattern view C. The radiation pattern view C is sliced in half along a vertical plane through the antenna. This produces the vertical plane pattern in view D. Note how the vertical plane in view D of the radiation pattern differs from the horizontal plane in view B. The vertical pattern view E exhibits two lobes and two nulls. The difference between the two patterns is caused by two facts: (1) no radiation is

emitted from the ends of the doublet; and (2) maximum radiation comes from the doublet in a direction perpendicular to the antenna axis. This type of radiation pattern is both NONDIRECTIONAL (in a horizontal plane) and DIRECTIONAL (in a vertical plane).

From a practical viewpoint, the doublet antenna can be mounted either vertically or horizontally. The doublet shown in figure 4-14 is mounted vertically, and the radiated energy spreads out about the antenna in every direction in the horizontal plane. Since ordinarily the horizontal plane is the useful plane, this arrangement is termed NONDIRECTIONAL. The directional characteristics of the antenna in other planes is ignored. If the doublet were mounted horizontally, it would have the effect of turning the pattern on edge, reversing the patterns given in figure 4-14. The antenna would then be directional in the horizontal plane. The terms "directional" and "nondirectional" are used for convenience in describing specific radiation patterns. A complete description always involves a figure in three dimensions, as in the radiation pattern of figure 4-14.

Q17. What terms are often used to describe basic half-wave antennas?

Q18. If a basic half-wave antenna is mounted vertically, what type of radiation pattern will be produced?

Q19. In which plane will the half-wave antenna be operating if it is mounted horizontally?

RADIATION PATTERN OF A DIPOLE.—The radiation pattern of a dipole (fig. 4-15) is similar to that of the doublet (fig. 4-14). Increasing the length of the doublet to $1/2$ wavelength has the effect of flattening out the radiation pattern. The radiation pattern in the horizontal plane of a dipole is a larger circle than that of the doublet. The vertical-radiation pattern lobes are no longer circular. They are flattened out and the radiation intensity is greater.

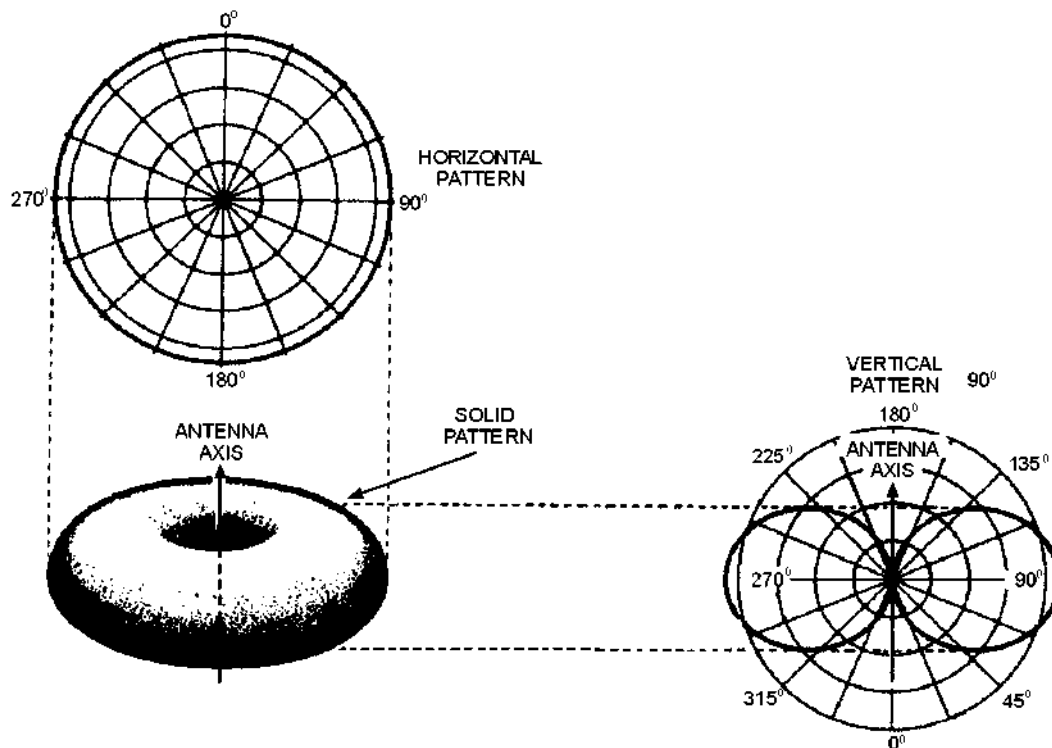

Figure 4-15.—Radiation pattern of a dipole.

Methods of Feeding Energy to an Antenna

Voltage and current distribution for the half-wave antenna (shown in figure 4-16) is the same as that for the antenna discussed earlier in this chapter. A point closely related to the voltage and current distribution on an antenna is the method of feeding the transmitter output to the antenna. The simplest method of feeding energy to the half-wave antenna is to connect one end through a capacitor to the final output stage of the transmitter. This method is often called the END-FEED or VOLTAGE-FEED method. In this method the antenna is fed at a point of high voltage (the end).

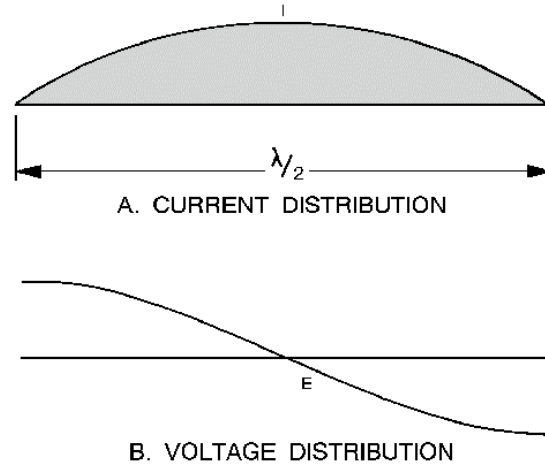

Figure 4-16.—Standing waves of current and voltage.

Energy may also be fed to the half-wave antenna by dividing the antenna at its center and connecting the transmission line from the final transmitter output stage to the two center ends of the halved antenna. Since the antenna is now being fed at the center (a point of low voltage and high current), this type of feed is known as the CENTER-FEED or CURRENT-FEED method. The point of feed is important in determining the type of transmission line to be used.

QUARTER-WAVE ANTENNAS

As you have studied in the previous sections, a $1/2$ wavelength antenna is the shortest antenna that can be used in free space. If we cut a half-wave antenna in half and then ground one end, we will have a grounded quarter-wave antenna. This antenna will resonate at the same frequency as the ungrounded half-wave antenna. Such an antenna is referred to as a QUARTER-WAVE or Marconi antenna. Quarter-wave antennas are widely used in the military. Most mobile transmitting and receiving antennas (fig. 4-17) are quarter-wave antennas.

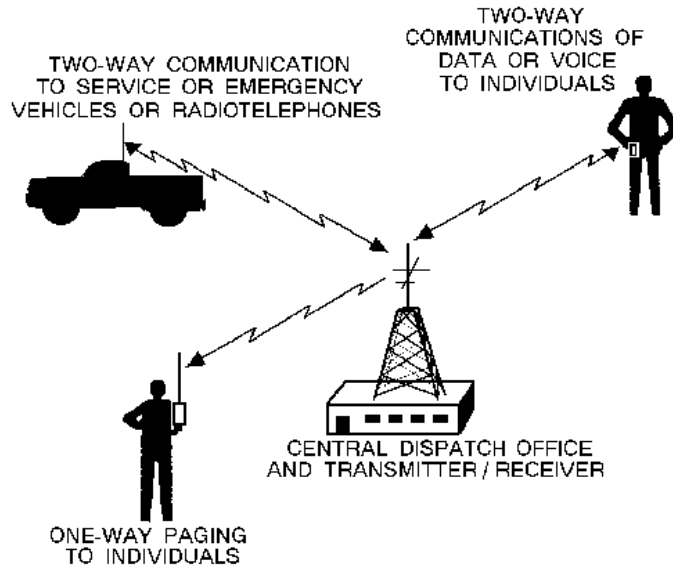

Figure 4-17.—Mobile antennas.

As stated above, a grounded quarter-wave antenna will resonate at the same frequency as an ungrounded half-wave antenna. This is because ground has high conductivity and acts as an electrical mirror image. This characteristic provides the missing half of the antenna, as shown in the bottom part of figure 4-18. In other words, the grounded quarter-wave antenna acts as if another quarter-wave were actually down in the earth.

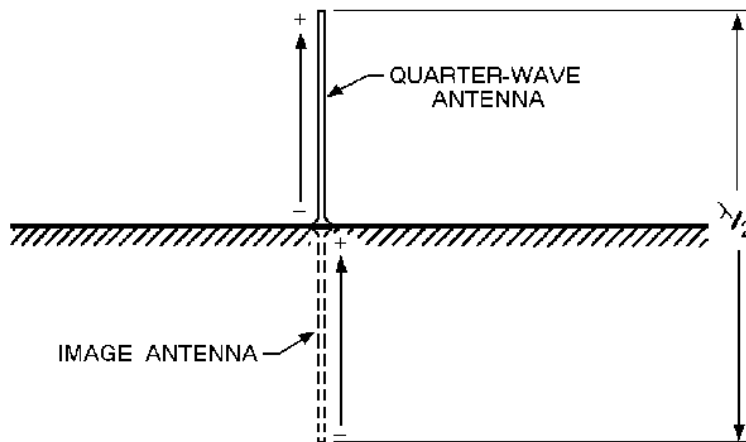

Figure 4-18.—Grounded quarter-wave antenna image.

Characteristics of Quarter-Wave Antennas

The grounded end of the quarter-wave antenna has a low input impedance and has low voltage and high current at the input end, as shown in figure 4-18. The ungrounded end has a high impedance, which causes high voltage and low current. The directional characteristics of a grounded quarter-wave antenna are the same as those of a half-wave antenna in free space.

As explained earlier, ground losses affect radiation patterns and cause high signal losses for some frequencies. Such losses may be greatly reduced if a perfectly conducting ground is provided in the

vicinity of the antenna. This is the purpose of a GROUND SCREEN (figure 4-19, view A) and COUNTERPOISE view B.

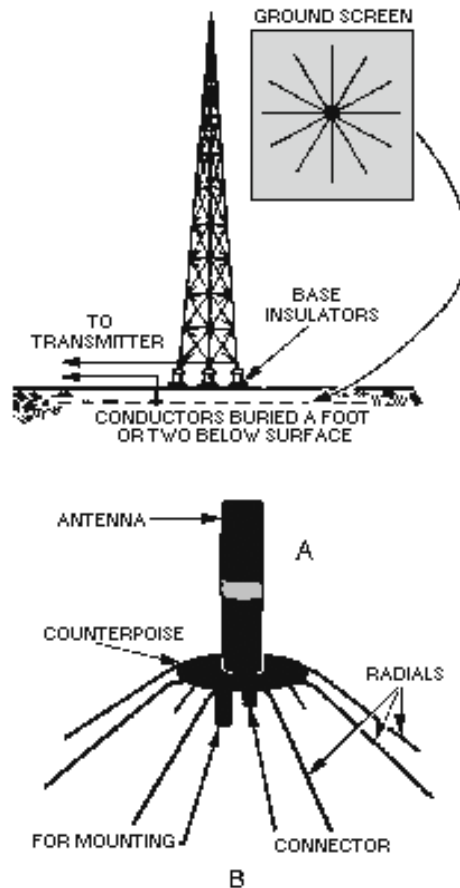

Figure 4-19.—Groundscreen and counterpoise.

The ground screen in view A is composed of a series of conductors buried 1 or 2 feet (0.3 to 0.6 meter) below the surface of the earth and arranged in a radial pattern. These conductors reduce losses in the ground in the immediate vicinity of the antenna. Such a radial system of conductors is usually $1/2$ wavelength in diameter.

A counterpoise view B is used when easy access to the base of the antenna is necessary. It is also used when the earth is not a good conducting surface, such as ground that is sandy or solid rock. The counterpoise serves the same purpose as the ground screen but it is usually elevated above the earth. No specific dimensions are necessary in the construction of a counterpoise nor is the number of wires particularly critical. A practical counterpoise may be assembled from a large screen of chicken wire or some similar material. This screen may be placed on the ground, but better results are obtained if it is placed a few feet above the ground.

Q20. Since the radiation pattern of a dipole is similar to that of a doublet, what will happen to the pattern if the length of the doublet is increased?

Q21. What is the simplest method of feeding power to the half-wave antenna?

Q22. What is the radiation pattern of a quarter-wave antenna?

Q23. Describe the physical arrangement of a ground screen.

FOLDED DIPOLE

The use of parasitic elements and various stacking arrangements causes a reduction in the radiation resistance of a center-fed, half-wave antenna. Under these conditions obtaining a proper impedance match between the radiator and the transmission line is often difficult. A convenient method of overcoming these difficulties is to use a FOLDED DIPOLE in place of the center-fed radiator. (See views A and B of figure 4-20).

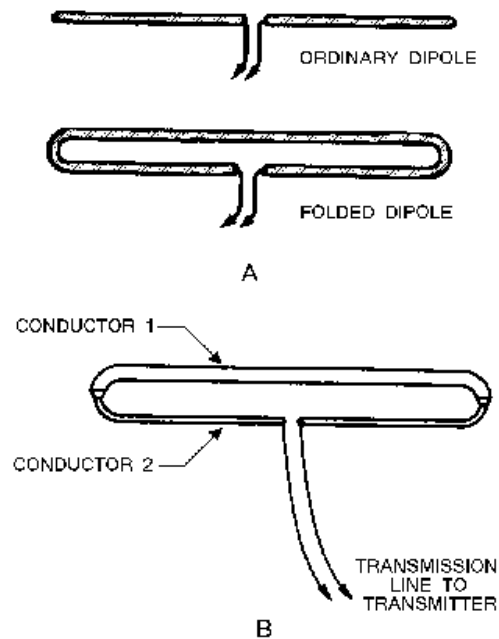

Figure 4-20.—Folded-dipole antennas.

A FOLDED DIPOLE is an ordinary half-wave antenna that has one or more additional conductors connected across its ends. Additional conductors are mounted parallel to the dipole elements at a distance equal to a very small fraction of a wavelength. Spacing of several inches is common.

The feed-point impedance can be further increased by using three or four properly spaced parallel conductors. Standard feed-line SPREADERS are used to maintain this spacing when required. In any folded dipole, the increase of impedance is the square of the number of conductors used in the radiator. Thus, a three-wire dipole has nine times (3^2) the feed-point impedance of a simple center-fed dipole. A second method of stepping up the impedance of a folded dipole is to use two conductors with different radii, as shown in view B.

The directional characteristics of a folded dipole are the same as those of a simple dipole. However, the reactance of a folded dipole varies much more slowly as the frequency is varied from resonance. Because of this the folded dipole can be used over a much wider frequency range than is possible with a simple dipole.

Q24. What is the difference in the amount of impedance between a three-wire dipole and a simple center-fed dipole?

Q25. Which has a wider frequency range, a simple dipole or a folded dipole?

ARRAY ANTENNAS

An array antenna is a special arrangement of basic antenna components involving new factors and concepts. Before you begin studying about arrays, you need to study some new terminology.

DEFINITION OF TERMS

An array antenna is made up of more than one ELEMENT, but the basic element is generally the dipole. Sometimes the basic element is made longer or shorter than a half-wave, but the deviation usually is not great.

A DRIVEN element is similar to the dipole you have been studying and is connected directly to the transmission line. It obtains its power directly from the transmitter or, as a receiving antenna, it delivers the received energy directly to the receiver. A PARASITIC ELEMENT is located near the driven element from which it gets its power. It is placed close enough to the driven element to permit coupling.

A parasitic element is sometimes placed so it will produce maximum radiation (during transmission) from its associated driver. When it operates to reinforce energy coming from the driver toward itself, the parasitic element is referred to as a DIRECTOR. If a parasitic element is placed so it causes maximum energy radiation in a direction away from itself and toward the driven element, that parasitic element is called a REFLECTOR.

If all of the elements in an array are driven, the array is referred to as a DRIVEN ARRAY (sometimes as a CONNECTED ARRAY). If one or more elements are parasitic, the entire system usually is considered to be a PARASITIC ARRAY.

MULTIELEMENT ARRAYS frequently are classified according to their directivity. A BIDIRECTIONAL ARRAY radiates in opposite directions along the line of maximum radiation. A UNIDIRECTIONAL ARRAY radiates in only one general direction.

Arrays can be described with respect to their radiation patterns and the types of elements of which they are made. However, you will find it useful to identify them by the physical placement of the elements and the direction of radiation with respect to these elements. Generally speaking, the term BROADSIDE ARRAY designates an array in which the direction of maximum radiation is perpendicular to the plane containing these elements. In actual practice, this term is confined to those arrays in which the elements themselves are also broadside, or parallel, with respect to each other.

A COLLINEAR ARRAY is one in which all the elements lie in a straight line with no radiation at the ends of the array. The direction of maximum radiation is perpendicular to the axis of the elements.

An END-FIRE ARRAY is one in which the principal direction of radiation is along the plane of the array and perpendicular to the elements. Radiation is from the end of the array, which is the reason this arrangement is referred to as an end-fire array.

Sometimes a system uses the characteristics of more than one of the three types mentioned. For instance, some of the elements may be collinear while others may be parallel. Such an arrangement is

often referred to as a COMBINATION ARRAY or an ARRAY OF ARRAYS. Since maximum radiation occurs at right angles to the plane of the array, the term broadside array is also used.

The FRONT-TO-BACK RATIO is the ratio of the energy radiated in the principal direction compared to the energy radiated in the opposite direction for a given antenna.

PHASING

Various reflected and refracted components of the propagated wave create effects of reinforcement and cancellation. At certain distant points from the transmitter, some of the wave components meet in space. Reception at these points is either impaired or improved. If the different components arrive at a given point in the same phase, they add, making a stronger signal available. If they arrive out of phase, they cancel, reducing the signal strength.

Radiation Pattern

Effects similar to those described in the preceding paragraph can be produced at the transmitting point itself. Consider the antennas shown in figure 4-21, views A and B. View A shows an unobstructed view of the radiation pattern of a single dipole. In view B two dipoles, shown as points 1 and 2, are perpendicular to the plane of the page. They are spaced $1/4$ wavelength apart at the operating frequency. The radiation pattern from either antenna 1 or 2, operating alone, would be uniform in all directions in this plane, as shown in view A. Suppose that current is being fed to both antennas from the same transmitter in such a way that the current fed to antenna 2 lags the current in antenna 1 by 90 degrees. Energy radiating from antenna 1 toward receiving location X will reach antenna 2 after $1/4$ cycle of operation. The energy from both antennas will add, and propagation toward X will be strong.

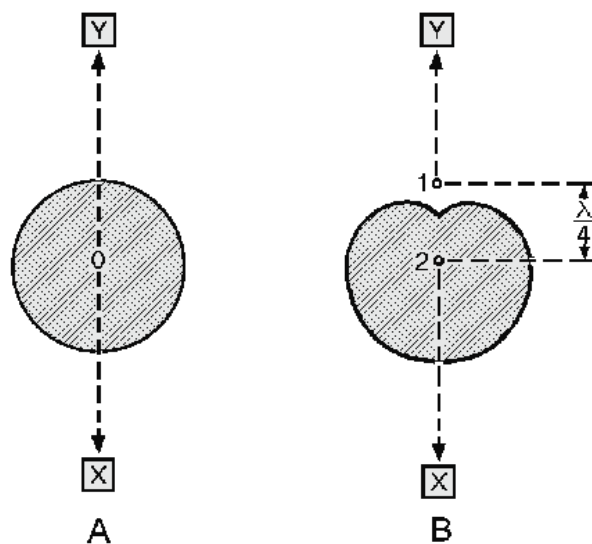

Figure 4-21.—Phasing of antenna in free space.

Radiation from antenna 2 toward receiving location Y will reach antenna 1 after $1/4$ cycle. The energy in antenna 1 was $1/4$ cycle behind that of antenna 2 to begin with; therefore, the radiation from antenna 1 toward receiving point Y will be exactly 180 degrees out of phase with that of antenna 2. As a result, the radiation fields will cancel and there will be no radiation toward Y.

At receiving points away from the line of radiation, phase differences occur between 0 and 180 degrees, producing varying amounts of energy in that direction. The overall effect is shown by the

radiation pattern shown in view B. The physical phase relationship caused by the 1/4-wavelength spacing between the two elements, as well as the phase of the currents in the elements, has acted to change the radiation pattern of the individual antennas.

Stub Phasing

In the case just discussed, the currents fed to the two antennas from the same transmitter were 90 degrees out of phase. Sections of transmission line, called STUBS, are frequently used for this purpose. These stubs can be adjusted to produce any desired phase relationship between connected elements.

When two collinear half-wave elements are connected directly so their currents are in the same phase, the effect is the same as that of a full-wave antenna, as shown in figure 4-22, view A. The current in the first 1/2 wavelength is exactly 180 degrees out of phase with that in the second 1/2 wavelength. This is the opposite of the desired condition. In the illustration, arrows are used to indicate the direction of current flow in the antenna. (Using arrows is a convenient means of determining the phase on more complicated arrays.)

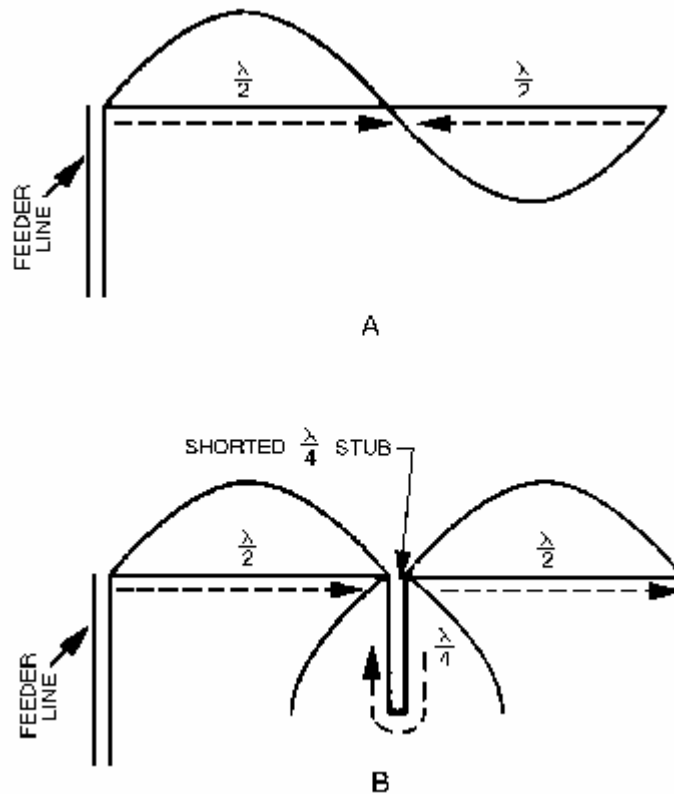

Figure 4-22.—Phasing of connected elements.

When the two elements are connected by a shorted 1/4-wavelength stub, as shown in view B, current travels down one side of the stub and up the other. It travels a distance of a 1/2 wavelength in the stub itself. As a result, the current moves through 1/2 cycle of change. When the current reaches the second element, it is in the desired phase. Since the current on one side of the stub is equal and opposite to the current on the other side, the fields produced here cancel and no radiation is transmitted from the stub itself.

DIRECTIVITY

The DIRECTIVITY of an antenna or an array can be determined by looking at its radiation pattern. In an array propagating a given amount of energy, more radiation takes place in certain directions than in others. The elements in the array can be altered in such a way that they change the pattern and distribute it more uniformly in all directions. The elements can be considered as a group of antennas fed from a common source and facing different directions. On the other hand, the elements could be arranged so that the radiation would be focused in a single direction. With no increase in power from the transmitter, the amount of radiation in a given direction would be greater. Since the input power has no increase, this increased directivity is achieved at the expense of gain in other directions.

Directivity and Interference

In many applications, sharp directivity is desirable although no need exists for added gain. Examine the physical disposition of the units shown in figure 4-23. Transmitters 1 and 2 are sending information to receivers 1 and 2, respectively, along the paths shown by the solid arrows. The distance between transmitter 1 and receiver 1 or between transmitter 2 and receiver 2 is short and does not require high-power transmission. The antennas of the transmitters propagate well in all directions. However, receiver 1 picks up some of the signals from transmitter 2, and receiver 2 picks up some of the signals from transmitter 1, as shown by the broken arrows. This effect is emphasized if the receiving antennas intercept energy equally well in all directions.

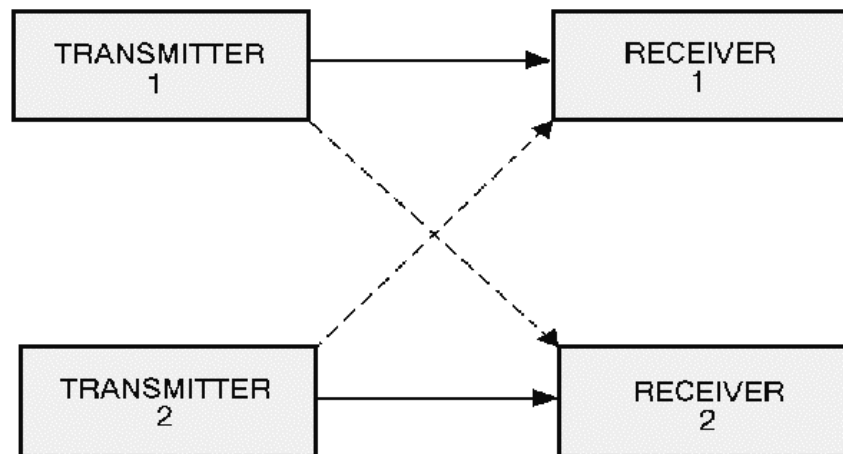

Figure 4-23.—Directivity and interference.

The use of highly directional arrays as radiators from the transmitters tends to solve the problem. The signals are beamed along the paths of the solid arrows and provide very low radiation along the paths of the broken arrows. Further improvement along these lines is obtained by the use of narrowly directed arrays as receiving antennas. The effect of this arrangement is to select the desired signal while discriminating against all other signals. This same approach can be used to overcome other types of radiated interference. In such cases, preventing radiation in certain directions is more important than producing greater gain in other directions.

Look at the differences between the field patterns of the single-element antenna and the array, as illustrated in figure 4-24. View A shows the relative field-strength pattern for a horizontally polarized single antenna. View B shows the horizontal-radiation pattern for an array. The antenna in view A

radiates fairly efficiently in the desired direction toward receiving point X. It radiates equally as efficiently toward Y, although no radiation is desired in this direction. The antenna in view B radiates strongly to point X, but very little in the direction of point Y, which results in more satisfactory operation.

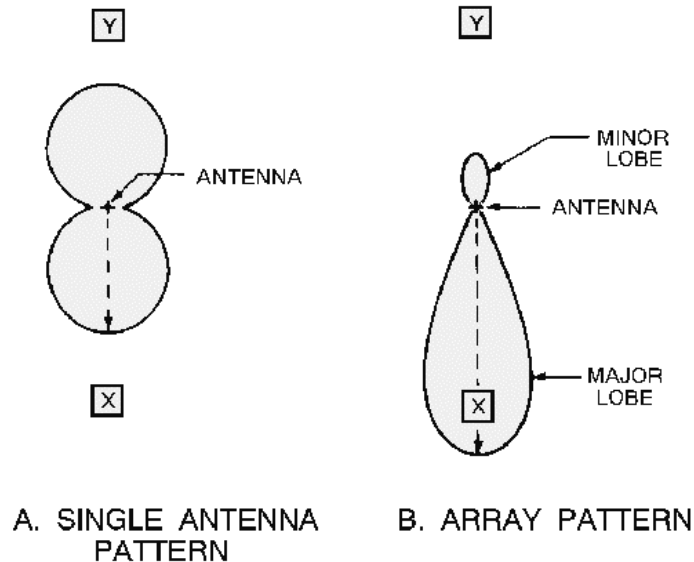

Figure 4-24.—Single antenna versus array.

Major and Minor Lobes

The pattern shown in figure 4-24, view B, has radiation concentrated in two lobes. The radiation intensity in one lobe is considerably stronger than in the other. The lobe toward point X is called a MAJOR LOBE; the other is a MINOR LOBE. Since the complex radiation patterns associated with arrays frequently contain several lobes of varying intensity, you should learn to use appropriate terminology. In general, major lobes are those in which the greatest amount of radiation occurs. Minor lobes are those in which the radiation intensity is least.

Q26. What is the purpose of antenna stubs?

Q27. What is the primary difference between the major and minor lobes of a radiation pattern?

DIRECTIONAL ARRAYS

You have already learned about radiation patterns and directivity of radiation. These topics are important to you because using an antenna with an improper radiation pattern or with the wrong directivity will decrease the overall performance of the system. In the following paragraphs, we discuss in more detail the various types of directional antenna arrays mentioned briefly in the "definition of terms" paragraph above.

Collinear Array

The pattern radiated by the collinear array is similar to that produced by a single dipole. The addition of the second radiator, however, tends to intensify the pattern. Compare the radiation pattern of the dipole (view A of figure 4-25) and the two-element antenna in view B. You will see that each pattern consists of two major lobes in opposite directions along the same axis, QQ1. There is little or no radiation along the

PP1 axis. QQ1 represents the line of maximum propagation. You can see that radiation is stronger with an added element. The pattern in view B is sharper, or more directive, than that in view A. This means that the gain along the line of maximum energy propagation is increased and the beam width is decreased. As more elements are added, the effect is heightened, as shown in view C. Unimportant minor lobes are generated as more elements are added.

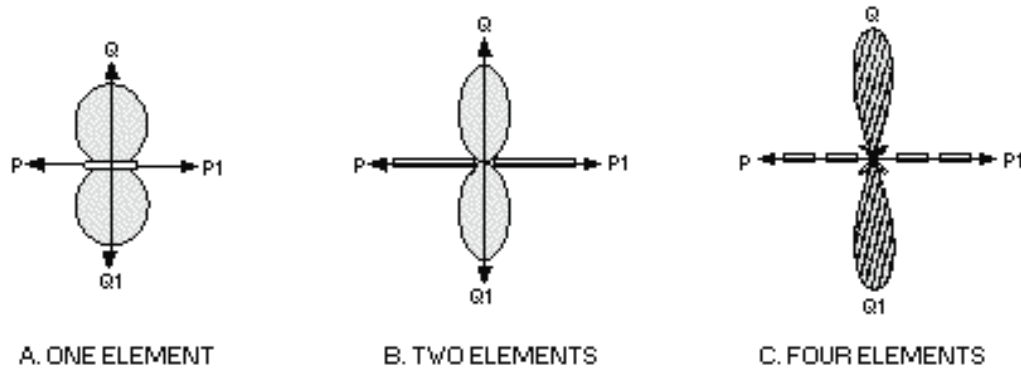

Figure 4-25.—Single half-wave antenna versus two half-wave antennas in phase.

More than four elements are seldom used because accumulated losses cause the elements farther from the point of feeding to have less current than the nearer ones. This introduces an unbalanced condition in the system and impairs its efficiency. Space limitations often are another reason for restricting the number of elements. Since this type of array is in a single line, rather than in a vertically stacked arrangement, the use of too many elements results in an antenna several wavelengths long.

RADIATION PATTERN.—The characteristic radiation pattern of a given array is obtained at the frequency or band of frequencies at which the system is resonant. The gain and directivity characteristics are lost when the antenna is not used at or near this frequency and the array tunes too sharply. A collinear antenna is more effective than an end-fire array when used off its tuned frequency. This feature is considered when transmission or reception is to be over a wide frequency band. When more than two elements are used, this advantage largely disappears.

LENGTH AND PHASING.—Although the $1/2$ wavelength is the basis for the collinear element, you will find that greater lengths are often used. Effective arrays of this type have been constructed in which the elements are 0.7 and even 0.8 wavelength long. This type of array provides efficient operation at more than one frequency or over a wider frequency range. Whatever length is decided upon, all of the elements in a particular array should closely adhere to that length. If elements of different lengths are combined, current phasing and distribution are changed, throwing the system out of balance and seriously affecting the radiation pattern.

Q28. What is the maximum number of elements ordinarily used in a collinear array?

Q29. Why is the number of elements used in a collinear array limited?

Q30. How can the frequency range of a collinear array be increased?

Q31. How is directivity of a collinear array affected when the number of elements is increased?

SPACING.—The lower relative efficiency of collinear arrays of many elements, compared with other multi-element arrays, relates directly to spacing and mutual impedance effects. Mutual impedance is

an important factor to be considered when any two elements are parallel and are spaced so that considerable coupling is between them. There is very little mutual impedance between collinear sections. Where impedance does exist, it is caused by the coupling between the ends of adjacent elements. Placing the ends of elements close together is frequently necessary because of construction problems, especially where long lengths of wire are involved.

The effects of spacing and the advantages of proper spacing can be demonstrated by some practical examples. A collinear array consisting of two half-wave elements with $1/4$ -wavelength spacing between centers has a gain of 1.8 dB. If the ends of these same dipoles are separated so that the distance from center to center is $3/4$ wavelengths and they are driven from the same source, the gain increases to approximately 2.9 dB.

A three-dipole array with negligible spacing between elements gives a gain of 3.3 dB. In other words, when two elements are used with wider spacing, the gain obtained is approximately equal to the gain obtainable from three elements with close spacing. The spacing of this array permits simpler construction, since only two dipoles are used. It also allows the antenna to occupy less space. Construction problems usually dictate small-array spacing.

Broadside Arrays

A broadside array is shown in figure 4-26, view A. Physically, it looks somewhat like a ladder. When the array and the elements in it are polarized horizontally, it looks like an upright ladder. When the array is polarized vertically, it looks like a ladder lying on one side (view B). View C is an illustration of the radiation pattern of a broadside array. Horizontally polarized arrays using more than two elements are not common. This is because the requirement that the bottom of the array be a significant distance above the earth presents construction problems. Compared with collinear arrays, broadside arrays tune sharply, but lose efficiency rapidly when not operated on the frequencies for which they are designed.

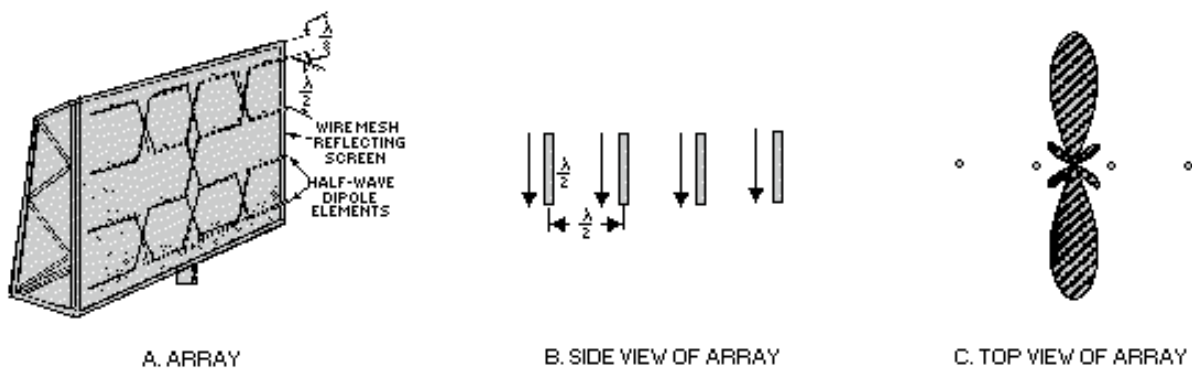

Figure 4-26.—Typical broadside array.

RADIATION PATTERN.—Figure 4-27 shows an end view of two parallel half-wave antennas (A and B) operating in the same phase and located $1/2$ wavelength apart. At a point (P) far removed from the antennas, the antennas appear as a single point. Energy radiating toward P from antenna A starts out in phase with the energy radiating from antenna B in the same direction. Propagation from each antenna travels over the same distance to point P, arriving there in phase. The antennas reinforce each other in this direction, making a strong signal available at P. Field strength measured at P is greater than it would be if the total power supplied to both antennas had been fed to a single dipole. Radiation toward point P1 is built up in the same manner.

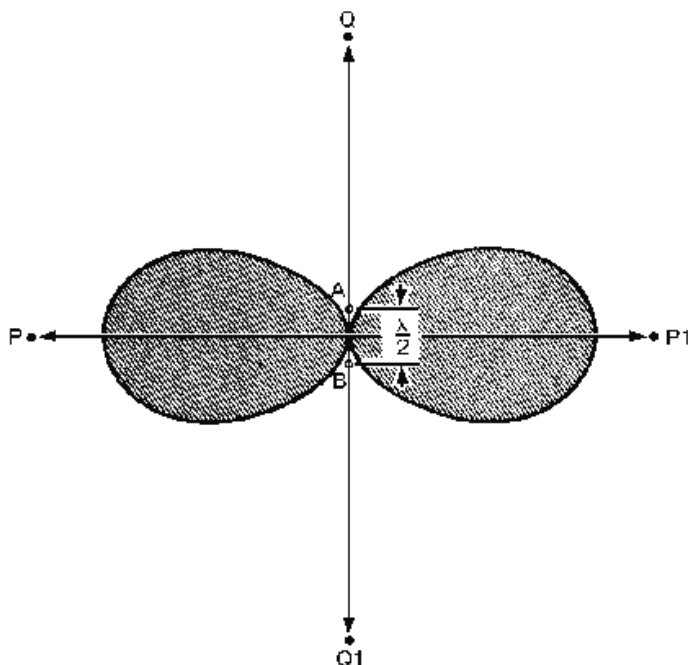

Figure 4-27.—Parallel elements in phase.

Next consider a wavefront traveling toward point Q from antenna B. By the time it reaches antenna A, $1/2$ wavelength away, $1/2$ cycle has elapsed. Therefore energy from antenna B meets the energy from antenna A 180 degrees out of phase. As a result, the energy moving toward point Q from the two sources cancels. In a like manner, radiation from antenna A traveling toward point Q1 meets and cancels the radiation in the same direction from antenna B. As a result, little propagation takes place in either direction along the QQ1 axis. Most of the energy is concentrated in both directions along the PP1 axis. When both antenna elements are fed from the same source, the result is the basic broadside array.

When more than two elements are used in a broadside arrangement, they are all parallel and in the same plane, as shown in figure 4-26, view B. Current phase, indicated by the arrows, must be the same for all elements. The radiation pattern shown in figure 4-26, view C, is always bi-directional. This pattern is sharper than the one shown in figure 4-27 because of the additional two elements. Directivity and gain depend on the number of elements and the spacing between them.

GAIN AND DIRECTIVITY.—The physical disposition of dipoles operated broadside to each other allows for much greater coupling between them than can occur between collinear elements. Moving the parallel antenna elements closer together or farther apart affects the actual impedance of the entire array and the overall radiation resistance as well. As the spacing between broadside elements increases, the effect on the radiation pattern is a sharpening of the major lobes. When the array consists of only two dipoles spaced exactly $1/2$ wavelength apart, no minor lobes are generated at all. Increasing the distance between the elements beyond that point, however, tends to throw off the phase relationship between the original current in one element and the current induced in it by the other element. The result is that, although the major lobes are sharpened, minor lobes are introduced, even with two elements. These, however, are not large enough to be of concern.

If you add the same number of elements to both a broadside array and a collinear array, the gain of the broadside array will be greater. Reduced radiation resistance resulting from the efficient coupling between dipoles accounts for most of this gain. However, certain practical factors limit the number of

elements that may be used. The construction problem increases with the number of elements, especially when they are polarized horizontally.

- Q32. *What is the primary cause of broadside arrays losing efficiency when not operating at their designed frequency?*
- Q33. *When more than two elements are used in a broadside array, how are the elements arranged?*
- Q34. *As the spacing between elements in a broadside array increases, what is the effect on the major lobes?*

End-Fire Arrays

An end-fire array looks similar to a broadside array. The ladder-like appearance is characteristic of both (fig. 4-28, view A). The currents in the elements of the end-fire array, however, are usually 180 degrees out of phase with each other as indicated by the arrows. The construction of the end-fire array is like that of a ladder lying on its side (elements horizontal). The dipoles in an end-fire array are closer together ($1/8$ -wavelength to $1/4$ -wavelength spacing) than they are for a broadside array.

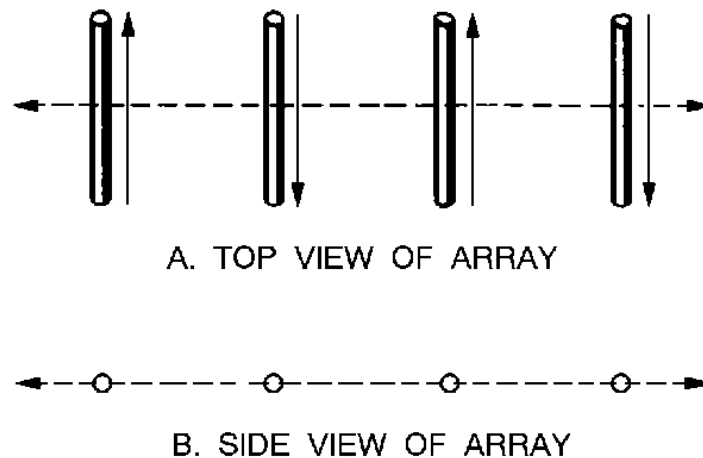

Figure 4-28.—Typical end-fire array.

Closer spacing between elements permits compactness of construction. For this reason an end-fire array is preferred to other arrays when high gain or sharp directivity is desired in a confined space. However, the close coupling creates certain disadvantages. Radiation resistance is extremely low, sometimes as low as 10 ohms, making antenna losses greater. The end-fire array is confined to a single frequency. With changes in climatic or atmospheric conditions, the danger of detuning exists.

RADIATION PATTERN.—The radiation pattern for a pair of parallel half-wave elements fed 180 degrees out of phase is shown in figure 4-29, view A. The elements shown are spaced $1/2$ wavelength apart. In practice, smaller spacings are used. Radiation from elements L and M traveling toward point P begins 180 degrees out of phase. Moving the same distance over approximately parallel paths, the respective wavefronts from these elements remain 180 degrees out of phase. In other words, maximum cancellation takes place in the direction of P. The same condition is true for the opposite direction (toward P1). The P to P1 axis is the line of least radiation for the end-fire array.

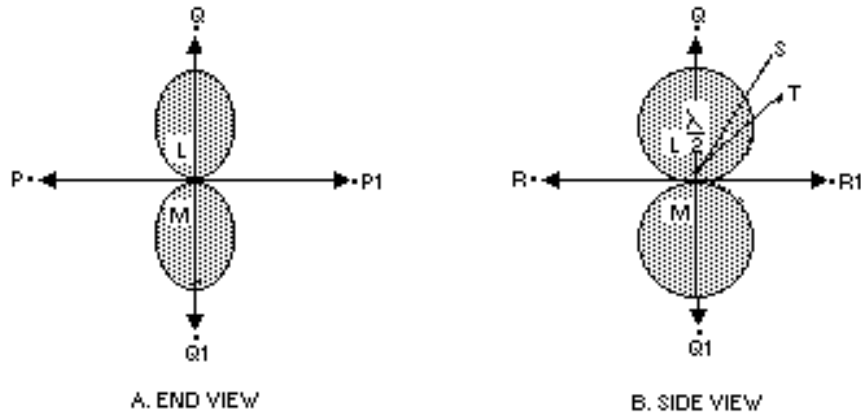

Figure 4-29.—Parallel elements 180 degrees out of phase.

Consider what happens along the QQ1 axis. Energy radiating from element M toward Q reaches element L in about 1/2 cycle (180 degrees) after it leaves its source. Since element L was fed 180 degrees out of phase with element M, the wavefronts are now in the same phase and are both moving toward Q reinforcing each other. Similar reinforcement occurs along the same axis toward Q1. This simultaneous movement towards Q and Q1 develops a bi-directional pattern. This is not always true in end-fire operation. Another application of the end-fire principle is one in which the elements are spaced 1/4 wavelength apart and phased 90 degrees from each other to produce a unidirectional pattern.

In figure 4-29, view A, elements A and B are perpendicular to the plane represented by the page; therefore, only the ends of the antennas appear. In view B the antennas are rotated a quarter of a circle in space around the QQ1 axis so that they are seen in the plane of the elements themselves. Therefore, the PP1 axis, now perpendicular to the page, is not seen as a line. The RR1 axis, now seen as a line, is perpendicular to the PP1 axis as well as to the QQ1 axis. The end-fire array is directional in this plane also, although not quite as sharply. The reason for the greater broadness of the lobes can be seen by following the path of energy radiating from the midpoint of element B toward point S in view B. This energy passes the A element at one end after traveling slightly more than the perpendicular distance between the dipoles. Energy, therefore, does not combine in exact phase toward point S. Although maximum radiation cannot take place in this direction, energy from the two sources combines closely enough in phase to produce considerable reinforcement. A similar situation exists for wavefronts traveling toward T. However, the wider angle from Q to T produces a greater phase difference and results in a decrease in the strength of the combined wave.

Directivity occurs from either one or both ends of the end-fire array, along the axis of the array, as shown by the broken arrows in figure 4-28, view A; hence, the term *end-fire* is used.

The major lobe or lobes occur along the axis of the array. The pattern is sharper in the plane that is at right angles to the plane containing the elements (figure 4-29, view A). If the elements are not exact half-wave dipoles, operation is not significantly affected. However, because of the required balance of phase relationships and critical feeding, the array must be symmetrical. Folded dipoles, such as the one shown in figure 4-20, view A, are used frequently because the impedance at their terminals is higher. This is an effective way of avoiding excessive antenna losses. Another expedient to reduce losses is the use of tubular elements of wide diameter.

GAIN AND DIRECTIVITY.—In end-fire arrays, directivity increases with the addition of more elements and with spacings approaching the optimum. The directive pattern for a two-element,

bi-directional system is illustrated in figure 4-29. View A shows radiation along the array axis in a plane perpendicular to the dipoles, and view B shows radiation along the array axis in the plane of the elements. These patterns were developed with a 180-degree phase difference between the elements. Additional elements introduce small, minor lobes.

With a 90-degree phase difference in the energy fed to a pair of end-fire elements spaced approximately $1/4$ wavelength apart, unidirectional radiation can be obtained. The pattern perpendicular to the plane of the two elements is shown in figure 4-30, view A. The pattern shown in view B, taken in the same plane, is for a six-element array with 90-degree phasing between adjacent elements. Since both patterns show relative gain only, the increase in gain produced by the six-element array is not evident. End-fire arrays are the only unidirectional arrays wholly made up of driven elements.

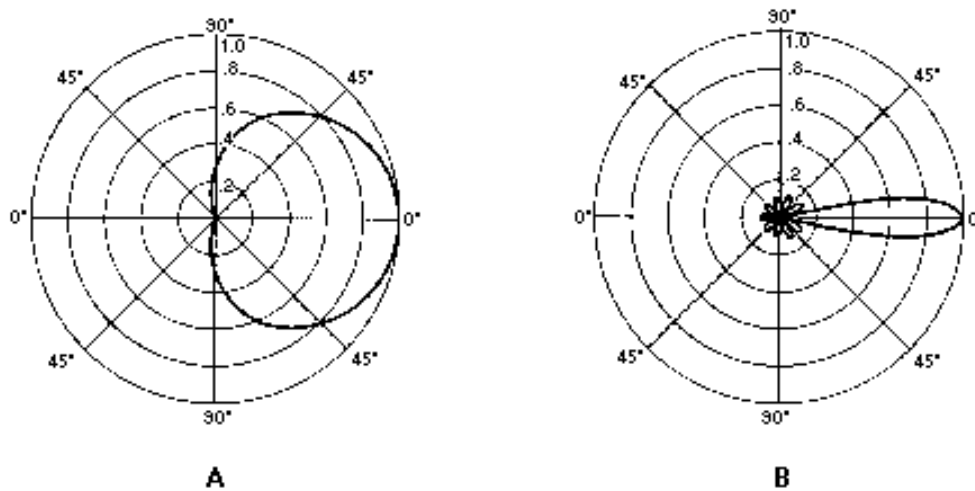

Figure 4-30.—Unidirectional end-fire arrays.

- Q35. *What are some disadvantages of the end-fire array?*
- Q36. *Where does the major lobe in the end-fire array occur?*
- Q37. *To maintain the required balance of phase relationships and critical feeding, how must the end-fire array be constructed?*

Parasitic Arrays

If a small light bulb were placed in the center of a large room, the illumination would be very poor. However, if a reflector were placed behind the bulb, the space in front of the reflector would be brighter and the space behind the reflector would be dimmer. The light rays would be concentrated. Also, if a lens were placed in front of the bulb, the light would be even more concentrated and a very bright spot would appear on the wall in front of the lens. A flashlight is a practical combination of the small bulb, the reflector, and the lens. The energy from an antenna can be reflected and concentrated in a similar manner.

Although we do not usually discuss the gain of a flashlight, we can continue the comparison of an antenna and a flashlight to explain the meaning of antenna gain. Suppose the spot on the wall in front of the flashlight becomes 10 times brighter than it was when only the open bulb was used. The lens and reflector have then produced a 10-fold gain in light. For antennas, the simple half-wave antenna corresponds to the open bulb in the flashlight. Suppose an antenna system concentrates the radio waves so

that at a particular point the field strength is 10 times more than it would be at the same distance from a half-wave antenna. The antenna system is then said to have a gain of 10.

Parasitic arrays represent another method of achieving high antenna gains. A parasitic array consists of one or more parasitic elements placed in parallel with each other and, in most cases, at the same line-of-sight level. The parasitic element is fed inductively by radiated energy coming from the driven element connected to the transmitter. It is in NO way connected directly to the driven element.

When the parasitic element is placed so that it radiates away from the driven element, the element is a director. When the parasitic element is placed so that it radiates toward the driven element, the parasitic element is a reflector.

The directivity pattern resulting from the action of parasitic elements depends on two factors. These are (1) the tuning, determined by the length of the parasitic element; and (2) the spacing between the parasitic and driven elements. To a lesser degree, it also depends on the diameter of the parasitic element, since diameter has an effect on tuning.

OPERATION.—When a parasitic element is placed a fraction of a wavelength away from the driven element and is of approximately resonant length, it will re-radiate the energy it intercepts. The parasitic element is effectively a tuned circuit coupled to the driven element, much as the two windings of a transformer are coupled together. The radiated energy from the driven element causes a voltage to be developed in the parasitic element, which, in turn, sets up a magnetic field. This magnetic field extends over to the driven element, which then has a voltage induced in it. The magnitude and phase of the induced voltage depend on the length of the parasitic element and the spacing between the elements. In actual practice the length and spacing are arranged so that the phase and magnitude of the induced voltage cause a unidirectional, horizontal-radiation pattern and an increase in gain.

In the parasitic array in figure 4-31, view A, the parasitic and driven elements are spaced $1/4$ wavelength apart. The radiated signal coming from the driven element strikes the parasitic element after $1/4$ cycle. The voltage developed in the parasitic element is 180 degrees out of phase with that of the driven element. This is because of the distance traveled (90 degrees) and because the induced current lags the inducing flux by 90 degrees ($90 + 90 = 180$ degrees). The magnetic field set up by the parasitic element induces a voltage in the driven element $1/4$ cycle later because the spacing between the elements is $1/4$ wavelength. This induced voltage is in phase with that in the driven element and causes an increase in radiation in the direction indicated in figure 4-31, view A. Since the direction of the radiated energy is stronger in the direction away from the parasitic element (toward the driven element), the parasitic element is called a reflector. The radiation pattern as it would appear if you were looking down on the antenna is shown in view B. The pattern as it would look if viewed from the ends of the elements is shown in view C.

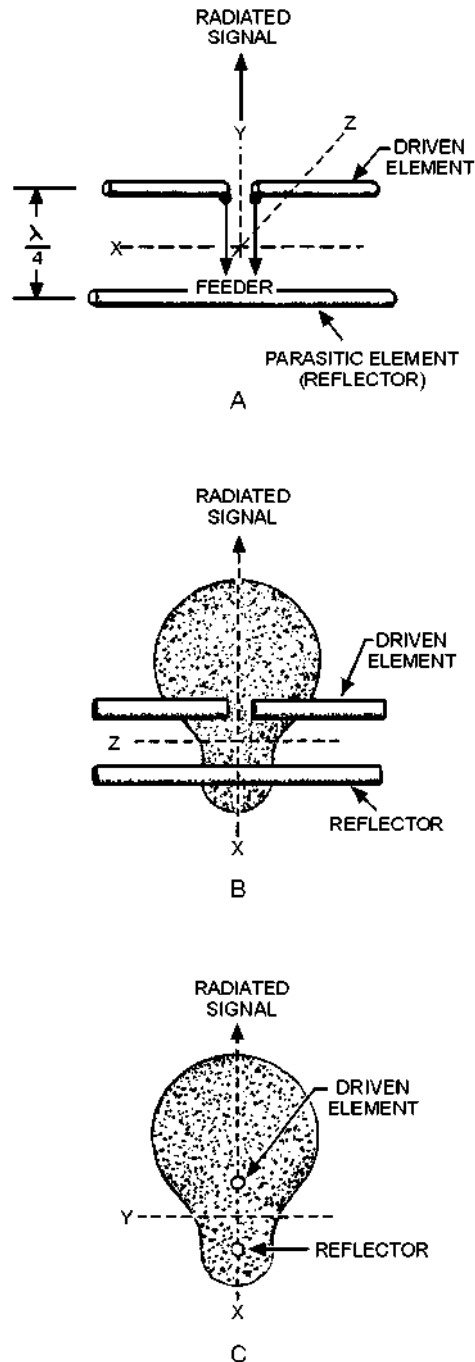

Figure 4-31.—Patterns obtained using a reflector with proper spacing.

Because the voltage induced in the reflector is 180 degrees out of phase with the signal produced at the driven element, a reduction in signal strength exists behind the reflector. Since the magnitude of an induced voltage never quite equals that of the inducing voltage, even in very closely coupled circuits, the energy behind the reflector (minor lobe) is not reduced to 0.

The spacing between the reflector and the driven element can be reduced to about 15 percent of a wavelength. The parasitic element must be made electrically inductive before it will act as a reflector. If

this element is made about 5 percent longer than $1/2$ wavelength, it will act as a reflector when the spacing is 15 percent of a wavelength.

Changing the spacing and length can change the radiation pattern so that maximum radiation is on the same side of the driven element as the parasitic element. In this instance the parasitic element is called a director.

Combining a reflector and a director with the driven element causes a decrease in back radiation and an increase in directivity. This combination results in the two main advantages of a parasitic array—unidirectivity and increased gain. If the parasitic array is rotated, it can pick up or transmit in different directions because of the reduction of transmitted energy in all but the desired direction. An antenna of this type is called a ROTARY ARRAY. Size for size, both the gain and directivity of parasitic arrays are greater than those of driven arrays. The disadvantage of parasitic arrays is that their adjustment is critical and they do not operate over a wide frequency range.

GAIN AND DIRECTIVITY.—Changing the spacing between either the director or the reflector and the driven element results in a change in the radiation pattern. More gain and directivity are obtained by changing the length of the parasitic elements.

The FRONT-TO-BACK RATIO of an array is the proportion of energy radiated in the principal direction of radiation to the energy radiated in the opposite direction. A high front-to-back ratio is desirable because this means that a minimum amount of energy is radiated in the undesired direction. Since completely suppressing all such radiation is impossible, an infinite ratio cannot be achieved. In actual practice, however, rather high values can be attained. Usually the length and spacing of the parasitic elements are adjusted so that a maximum front-to-back ratio is obtained, rather than maximum gain in the desired direction.

Q38. What two factors determine the directivity pattern of the parasitic array?

Q39. What two main advantages of a parasitic array can be obtained by combining a reflector and a director with the driven element?

Q40. The parasitic array can be rotated to receive or transmit in different directions. What is the name given to such an antenna?

Q41. What are the disadvantages of the parasitic array?

Multielement Parasitic Array

A MULTIELEMENT PARASITIC array is one that contains two or more parasitic elements with the driven element. If the array contains two parasitic elements (a reflector and a director) in addition to the driven element, it is usually known as a THREE-ELEMENT ARRAY. If three parasitic elements are used, the array is known as a FOUR-ELEMENT ARRAY, and so on. Generally speaking, if more parasitic elements are added to a three-element array, each added element is a director. The field behind a reflector is so small that additional reflectors would have little effect on the overall radiation pattern. In radar, from one to five directors are used.

CONSTRUCTION.—The parasitic elements of a multi-element parasitic array usually are positioned as shown in figure 4-32, views A and B. Proper spacings and lengths are determined experimentally. A folded dipole (view B) is often used as the driven element to obtain greater values of radiation resistance.

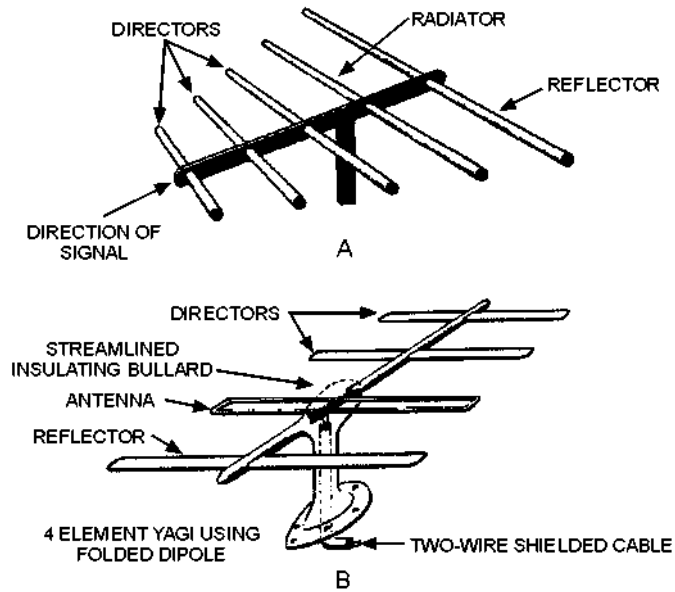

Figure 4-32.—Yagi antenna.

YAGI ANTENNAS.—An example of a multielement parasitic array is the YAGI ANTENNA (figure 4-32, views A and B). The spacings between the elements are not uniform. The radiation from the different elements arrives in phase in the forward direction, but out of phase by various amounts in the other directions.

The director and the reflector in the Yagi antenna are usually welded to a conducting rod or tube at their centers. This support does not interfere with the operation of the antenna. Since the driven element is center-fed, it is not welded to the supporting rod. The center impedance can be increased by using a folded dipole as the driven element.

The Yagi antenna shown in figure 4-32, view A, has three directors. In general, the greater number of parasitic elements used, the greater the gain. However, a greater number of such elements causes the array to have a narrower frequency response as well as a narrower beamwidth. Therefore, proper adjustment of the antenna is critical. The gain does not increase directly with the number of elements used. For example, a three-element Yagi array has a relative power gain of 5 dB. Adding another director results in a 2 dB increase. Additional directors have less and less effect.

A typical Yagi array used for receiving and transmitting energy is shown with a support frame in figure 4-33. This antenna is used by the military services. It operates at frequencies of from 12 to 50 megahertz and consists of two separate arrays (one high-frequency and one low-frequency antenna array) mounted on one frame. The various elements are indicated in the figure. The high-frequency (hf) array consists of one reflector, one driven element, and two directors; the low-frequency (lf) array has the same arrangement with one less director. The lengths of the elements in the high-frequency array are shorter than those in the low-frequency array. The physical lengths of the elements in the individual arrays are equal, but the electrical lengths can be varied by means of the tuning stubs at the center of the elements. The array can be rotated in any desired direction by a remotely controlled, electrically driven, antenna rotator.

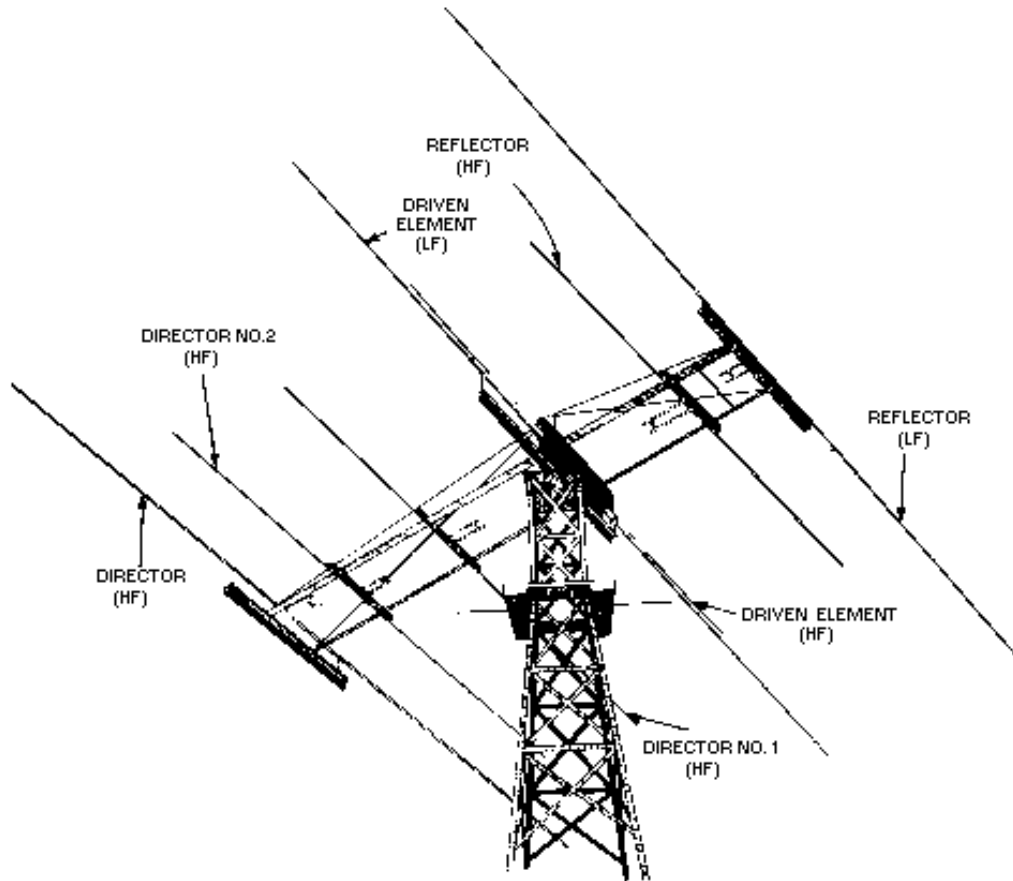

Figure 4-33.—A typical parasitic array used for transmitting and receiving.

Q42. What is the advantage of adding parasitic elements to a Yagi array?

Q43. The Yagi antenna is an example of what type of array?

SPECIAL ANTENNAS

In this section we will cover some special communications and radar antennas. Some of these antennas we touch on briefly since they are covered thoroughly in other courses.

Previously discussed antennas operate with standing waves of current and voltage along the wires. This section deals principally with antenna systems in which the current is practically uniform in all parts of the antenna. In its basic form, such an antenna consists of a single wire grounded at the far end through a resistor. The resistor has a value equal to the characteristic impedance of the antenna. This termination, just as in the case of an ordinary transmission line, eliminates standing waves. The current, therefore, decreases uniformly along the wire as the terminated end is approached. This decrease is caused by the loss of energy through radiation. The energy remaining at the end of the antenna is dissipated in the terminating resistor. For such an antenna to be a good radiator, its length must be fairly long. Also, the wire must not be too close to the ground. The return path through the ground will cause cancellation of the radiation. If the wire is sufficiently long, it will be practically nonresonant over a wide range of operating frequencies.

LONG-WIRE ANTENNA

A LONG-WIRE ANTENNA is an antenna that is a wavelength or longer at the operating frequency. In general, the gain achieved with long-wire antennas is not as great as the gain obtained from the multielement arrays studied in the previous section. But the long-wire antenna has advantages of its own. The construction of long-wire antennas is simple, both electrically and mechanically, with no particularly critical dimensions or adjustments. The long-wire antenna will work well and give satisfactory gain and directivity over a frequency range up to twice the value for which it was cut. In addition, it will accept power and radiate it efficiently on any frequency for which its overall length is not less than approximately $1/2$ wavelength. Another factor is that long-wire antennas have directional patterns that are sharp in both the horizontal and vertical planes. Also, they tend to concentrate the radiation at the low vertical angles. Another type of long-wire antenna is the BEVERAGE ANTENNA, also called a WAVE ANTENNA. It is a horizontal, long-wire antenna designed especially for the reception and transmission of low-frequency, vertically polarized ground waves. It consists of a single wire, two or more wavelengths long, supported 3 to 6 meters above the ground, and terminated in its characteristic impedance, as shown in figure 4-34.

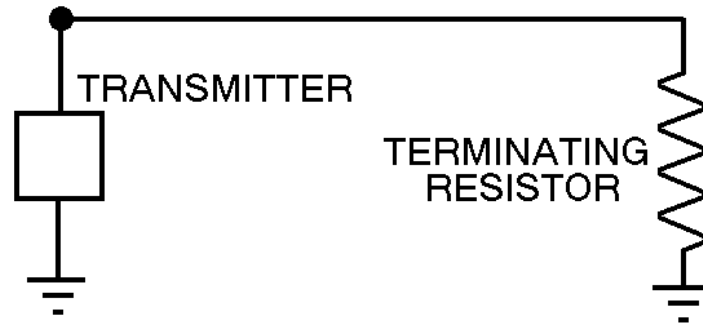

Figure 4-34.—Beverage antenna.

- Q44. To radiate power efficiently, a long-wire antenna must have what minimum overall length?
- Q45. What is another name for the Beverage antenna?

V ANTENNA

A V ANTENNA is a bi-directional antenna used widely in military and commercial communications. It consists of two conductors arranged to form a V. Each conductor is fed with currents of opposite polarity.

The V is formed at such an angle that the main lobes reinforce along the line bisecting the V and make a very effective directional antenna (see figure 4-35). Connecting the two-wire feed line to the apex of the V and exciting the two sides of the V 180 degrees out of phase cause the lobes to add along the line of the bisector and to cancel in other directions, as shown in figure 4-36. The lobes are designated 1, 2, 3, and 4 on leg AA', and 5, 6, 7, and 8 on leg BB'. When the proper angle between AA' and BB' is chosen, lobes 1 and 4 have the same direction and combine with lobes 7 and 6, respectively. This combination of two major lobes from each leg results in the formation of two stronger lobes, which lie along an imaginary line bisecting the enclosed angle. Lobes 2, 3, 5, and 8 tend to cancel each other, as do the smaller lobes, which are approximately at right angles to the wire legs of the V. The resultant waveform pattern is shown at the right of the V antenna in figure 4-36.

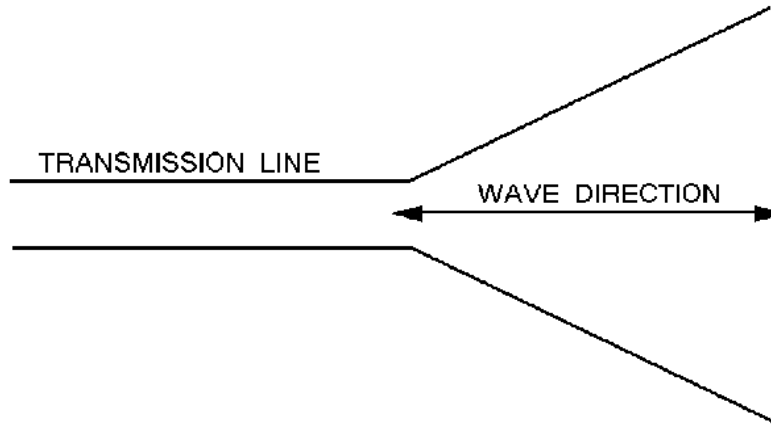

Figure 4-35.—Basic V antenna.

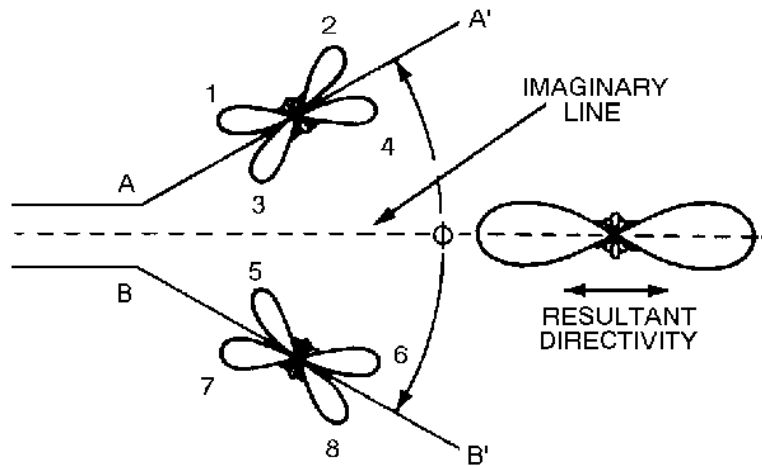

Figure 4-36.—Formation of directional radiation pattern from a resonant V antenna.

Q46. What is the polarity of the currents that feed the V antenna?

RHOMBIC ANTENNA

The highest development of the long-wire antenna is the RHOMBIC ANTENNA (see figure 4-37). It consists of four conductors joined to form a rhombus, or diamond shape. The antenna is placed end to end and terminated by a noninductive resistor to produce a uni-directional pattern. A rhombic antenna can be made of two obtuse-angle V antennas that are placed side by side, erected in a horizontal plane, and terminated so the antenna is nonresonant and unidirectional.

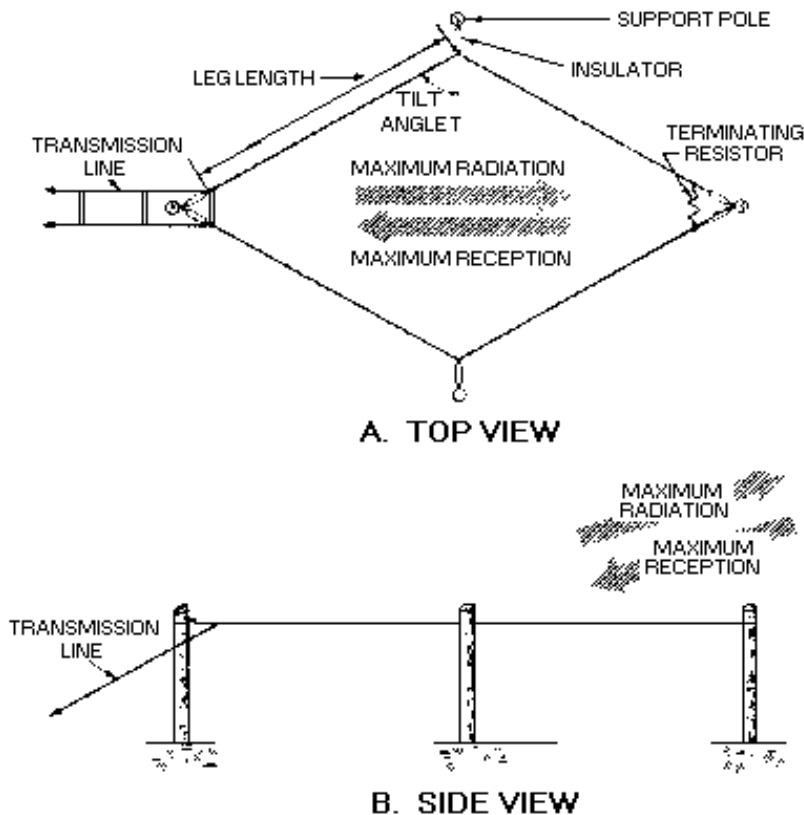

Figure 4-37.—Basic rhombic antenna.

The rhombic antenna is WIDELY used for long-distance, high-frequency transmission and reception. It is one of the most popular fixed-station antennas because it is very useful in point-to-point communications.

Advantages

The rhombic antenna is useful over a wide frequency range. Although some changes in gain, directivity, and characteristic impedance do occur with a change in operating frequency, these changes are small enough to be neglected.

The rhombic antenna is much easier to construct and maintain than other antennas of comparable gain and directivity. Only four supporting poles of common heights from 15 to 20 meters are needed for the antenna.

The rhombic antenna also has the advantage of being noncritical as far as operation and adjustment are concerned. This is because of the broad frequency characteristics of the antenna.

Still another advantage is that the voltages present on the antenna are much lower than those produced by the same input power on a resonant antenna. This is particularly important when high transmitter powers are used or when high-altitude operation is required.

Disadvantages

The rhombic antenna is not without its disadvantages. The principal one is that a fairly large antenna site is required for its erection. Each leg is made at least 1 or 2 wavelengths long at the lowest operating frequency. When increased gain and directivity are required, legs of from 8 to 12 wavelengths are used. These requirements mean that high-frequency rhombic antennas have wires of several hundred feet in length. Therefore, they are used only when a large plot of land is available.

Another disadvantage is that the horizontal and vertical patterns depend on each other. If a rhombic antenna is made to have a narrow horizontal beam, the beam is also lower in the vertical direction. Therefore, obtaining high vertical-angle radiation is impossible except with a very broad horizontal pattern and low gain. Rhombic antennas are used, however, for long-distance sky wave coverage at the high frequencies. Under these conditions low vertical angles of radiation (less than 20 degrees) are desirable. With the rhombic antenna, a considerable amount of the input power is dissipated uselessly in the terminating resistor. However, this resistor is necessary to make the antenna unidirectional. The great gain of the antenna more than makes up for this loss.

Radiation Patterns

Figure 4-38 shows the individual radiation patterns produced by the four legs of the rhombic antenna and the resultant radiation pattern. The principle of operation is the same as for the V and the half-rhombic antennas.

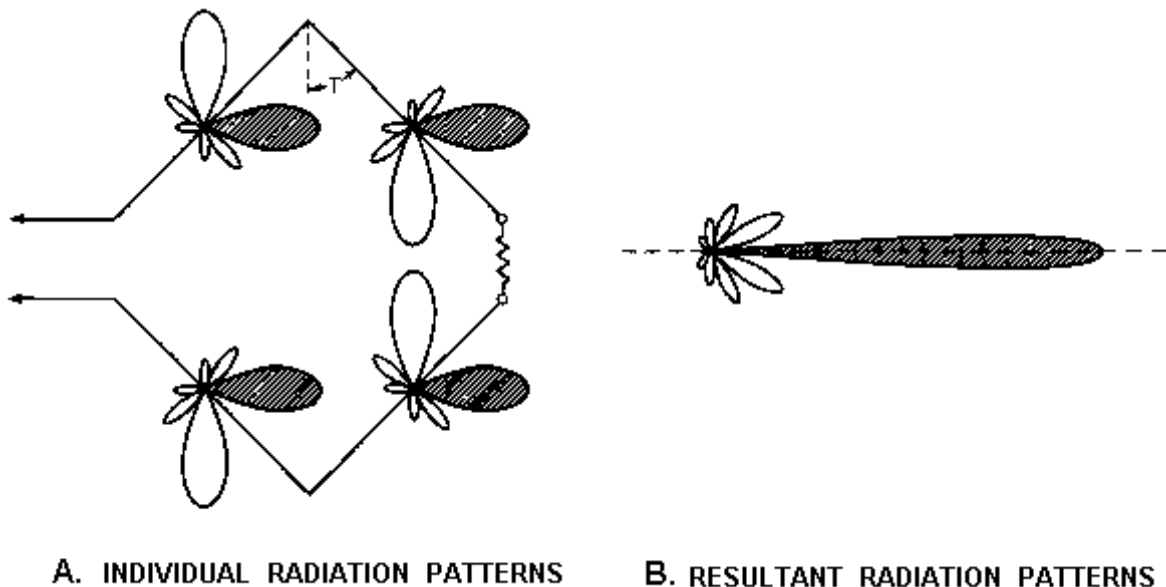

Figure 4-38.—Formation of a rhombic antenna beam.

Terminating Resistor

The terminating resistor plays an important part in the operation of the rhombic antenna. Upon it depend the unidirectionality of the antenna and the lack of resonance effects. An antenna should be properly terminated so it will have a constant impedance at its input. Terminating the antenna properly will also allow it to be operated over a wide frequency range without the necessity for changing the coupling adjustments at the transmitter. Discrimination against signals coming from the rear is of great importance

for reception. The reduction of back radiation is perhaps of lesser importance for transmission. When an antenna is terminated with resistance, the energy that would be radiated backward is absorbed in the resistor.

Q47. What is the main disadvantage of the rhombic antenna?

TURNSTILE ANTENNA

The TURNSTILE ANTENNA is one of the many types that has been developed primarily for omnidirectional vhf communications. The basic turnstile consists of two horizontal half-wave antennas mounted at right angles to each other in the same horizontal plane. When these two antennas are excited with equal currents 90 degrees out of phase, the typical figure-eight patterns of the two antennas merge to produce the nearly circular pattern shown in figure 4-39, view A. Pairs of such antennas are frequently stacked, as shown in figure 4-40. Each pair is called a BAY. In figure 4-40 two bays are used and are spaced $1/2$ wavelength apart, and the corresponding elements are excited in phase. These conditions cause a part of the vertical radiation from each bay to cancel that of the other bay. This results in a decrease in energy radiated at high vertical angles and increases the energy radiated in the horizontal plane. Stacking a number of bays can alter the vertical radiation pattern, causing a substantial gain in a horizontal direction without altering the overall horizontal directivity pattern. Figure 4-39, view B, compares the circular vertical radiation pattern of a single-bay turnstile with the sharp pattern of a four-bay turnstile array. A three-dimensional radiation pattern of a four-bay turnstile antenna is shown in figure 4-39, view C.

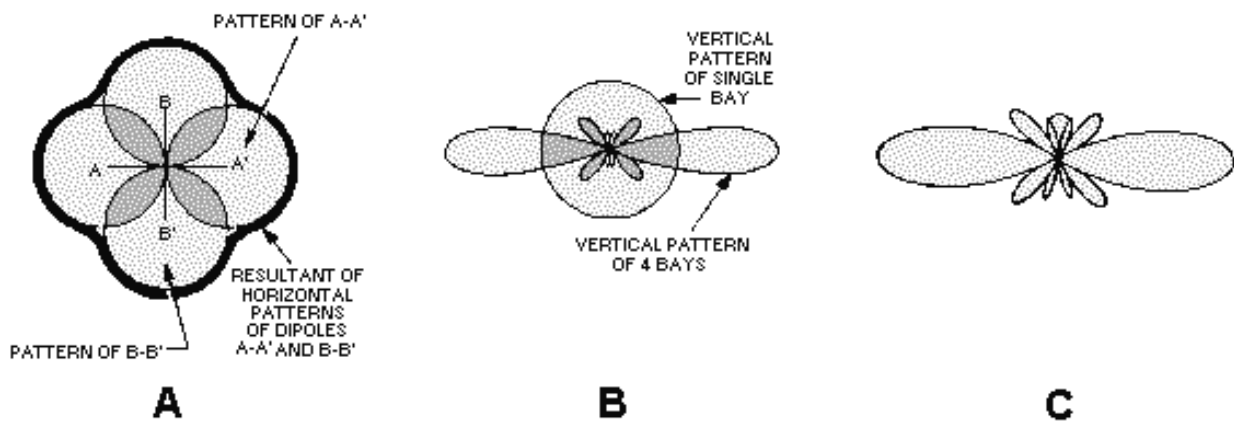

Figure 4-39.—Turnstile antenna radiation pattern.

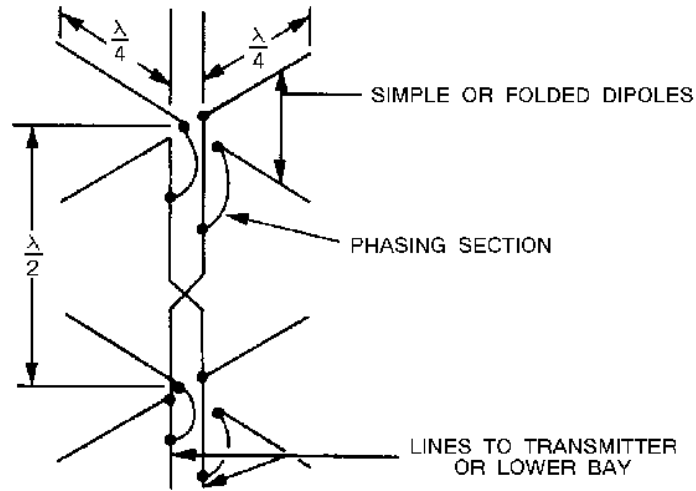

Figure 4-40.—Stacked turnstile antennas.

GROUND-PLANE ANTENNA

A vertical quarter-wave antenna several wavelengths above ground produces a high angle of radiation that is very undesirable at vhf and uhf frequencies. The most common means of producing a low angle of radiation from such an antenna is to work the radiator against a simulated ground called a GROUND PLANE. A simulated ground may be made from a large metal sheet or several wires or rods radiating from the base of the radiator. An antenna so constructed is known as a GROUND-PLANE ANTENNA. Two ground-plane antennas are shown in figure 4-41, views A and B.

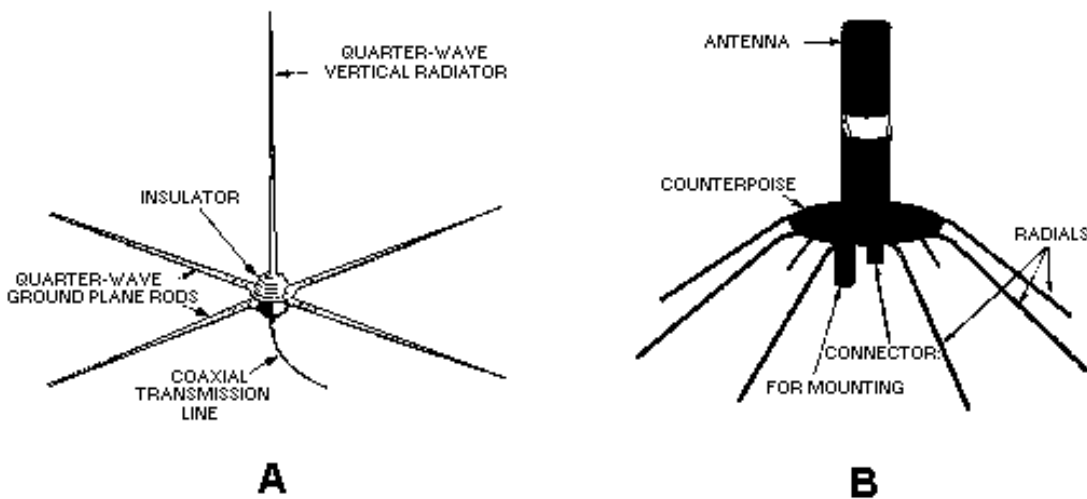

Figure 4-41.—Ground-plane antennas.

CORNER REFLECTOR

When a unidirectional radiation pattern is desired, it can be obtained by the use of a corner reflector with a half-wave dipole. A CORNER-REFLECTOR ANTENNA is a half-wave radiator with a reflector. The reflector consists of two flat metal surfaces meeting at an angle immediately behind the radiator. In other words, the radiator is set in the plane of a line bisecting the corner angle formed by the reflector

sheets. The construction of a corner reflector is shown in figure 4-42. Corner-reflector antennas are mounted with the radiator and the reflector in the horizontal position when horizontal polarization is desired. In such cases the radiation pattern is very narrow in the vertical plane, with maximum signal being radiated in line with the bisector of the corner angle. The directivity in the horizontal plane is approximately the same as for any half-wave radiator having a single-rod type reflector behind it. If the antenna is mounted with the radiator and the corner reflector in the vertical position, as shown in view A, maximum radiation is produced in a very narrow horizontal beam. Radiation in a vertical plane will be the same as for a similar radiator with a single-rod type reflector behind it.

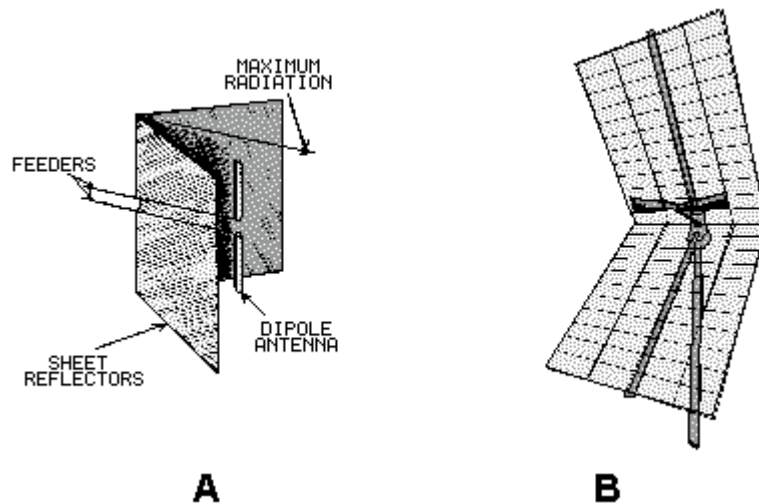

Figure 4-42.—Corner-reflector antennas.

Q48. What is the primary reason for the development of the turnstile antenna?

RF SAFETY PRECAUTIONS

Although electromagnetic radiation from transmission lines and antennas is usually of insufficient strength to electrocute personnel, it can lead to other accidents and compound injuries. Voltages may be induced in ungrounded metal objects, such as wire guys, wire cable (hawser), hand rails, or ladders. If you come in contact with these objects, you could receive a shock or rf burn. This shock can cause you to jump or fall into nearby mechanical equipment or, when working aloft, to fall from an elevated work area. Take care to ensure that all transmission lines or antennas are deenergized before working near or on them.

Either check or have someone check all guys, cables, rails, and ladders around your work area for rf shock dangers. Use working aloft "chits" and safety harnesses for your own safety. Signing a "working aloft chit" signifies that all equipment is in a nonradiating status. The person who signs the chit should ensure that no rf danger exists in areas where you or other personnel will be working.

Nearby ships or parked aircraft are another source of rf energy that you must consider when you check a work area for safety. Combustible materials can be ignited and cause severe fires from arcs or heat generated by rf energy. Also, rf radiation can detonate ordnance devices by inducing currents in the internal wiring of the devices or in the external test equipment or leads connected to them.

ALWAYS obey rf radiation warning signs and keep a safe distance from radiating antennas. The six types of warning signs for rf radiation hazards are shown in figure 4-43.

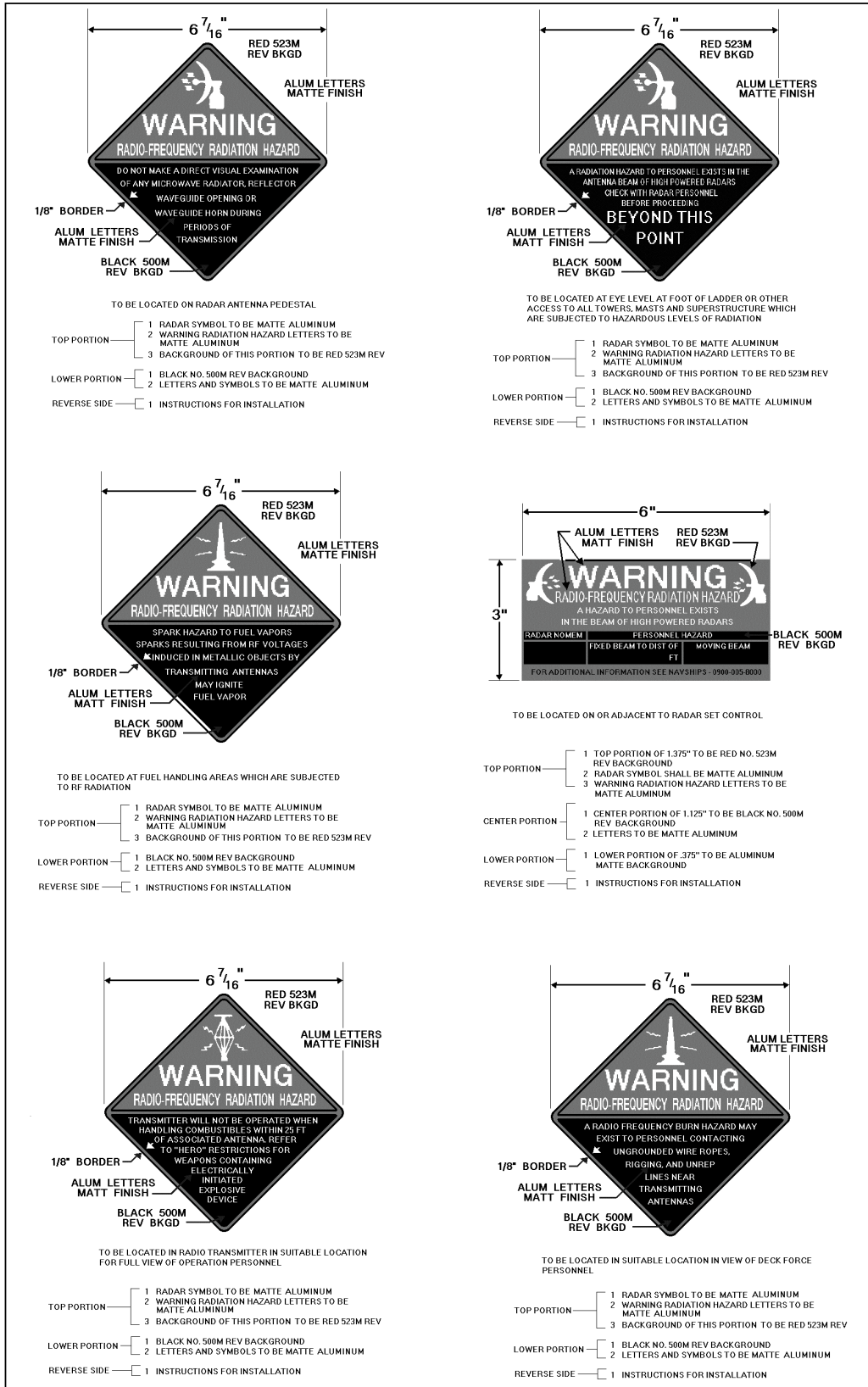

Figure 4-43.—Examples of rf radiation warning signs.

RF BURNS

Close or direct contact with rf transmission lines or antennas may result in rf burns. These are usually deep, penetrating, third-degree burns. To heal properly, these burns must heal from the inside to the skin's surface. To prevent infection, you must give proper attention to all rf burns, including the small "pinhole" burns. Petrolatum gauze can be used to cover these burns temporarily, before the injured person reports to medical facilities for further treatment.

DIELECTRIC HEATING

DIELECTRIC HEATING is the heating of an insulating material by placing it in a high-frequency electric field. The heat results from internal losses during the rapid reversal of polarization of molecules in the dielectric material.

In the case of a human in an rf field, the body acts as a dielectric. If the power in the rf field exceeds 10 milliwatts per centimeter, a person in that field will have a noticeable rise in body temperature. The eyes are highly susceptible to dielectric heating. For this reason, you should not look directly into devices radiating rf energy. The vital organs of the body also are susceptible to dielectric heating. For your own safety, you must NOT stand directly in the path of rf radiating devices.

PRECAUTIONS WHEN WORKING ALOFT

When radio or radar antennas are energized by transmitters, you must not go aloft unless advance tests show that little or no danger exists. A casualty can occur from even a small spark drawn from a charged piece of metal or rigging. Although the spark itself may be harmless, the "surprise" may cause you to let go of the antenna involuntarily and you may fall. There is also a shock hazard if nearby antennas are energized.

Rotating antennas also might cause you to fall when you are working aloft. Motor safety switches controlling the motion of rotating antennas must be tagged and locked open before you go aloft near such antennas.

When working near a stack, you should draw and wear the recommended oxygen breathing apparatus. Among other toxic substances, stack gas contains carbon monoxide. Carbon monoxide is too unstable to build up to a high concentration in the open, but prolonged exposure to even small quantities is dangerous.

SUMMARY

This chapter has presented information on the various types of antennas. The information that follows summarizes the important points of this chapter.

An **ANTENNA** is a conductor, or system of conductors, that radiates or receives energy in the form of electromagnetic waves.

HERTZ (half-wave) and **MARCONI** (quarter-wave) are the two basic classifications of antennas.

RECIPROCITY of antennas means that the various properties of the antenna apply equally to transmitting and receiving.

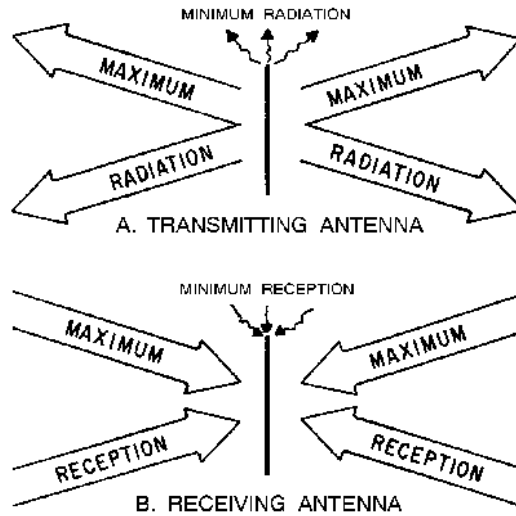

RADIATION RESISTANCE is the amount of resistance which, if inserted in place of the antenna, would consume the same amount of power that is actually radiated by the antenna.

RADIATION PATTERNS can be plotted on a rectangular- or polar-coordinate graph. These patterns are a measurement of the energy leaving an antenna.

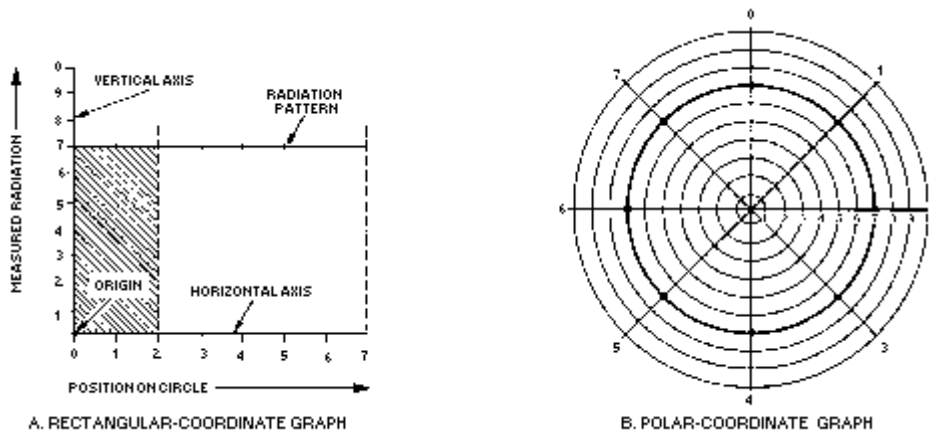

An **ISOTROPIC RADIATOR** radiates energy equally in all directions.

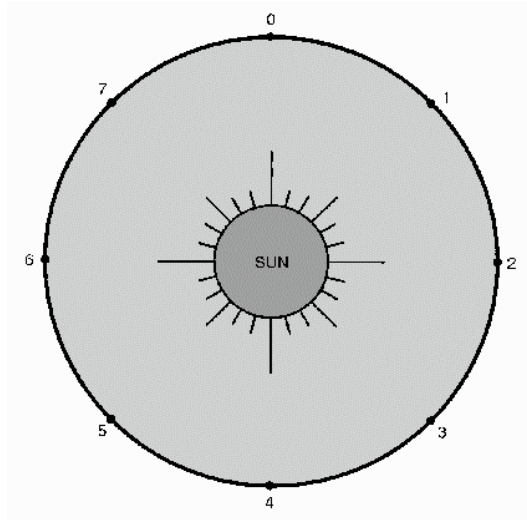

An **ANISOTROPIC RADIATOR** radiates energy directionally.

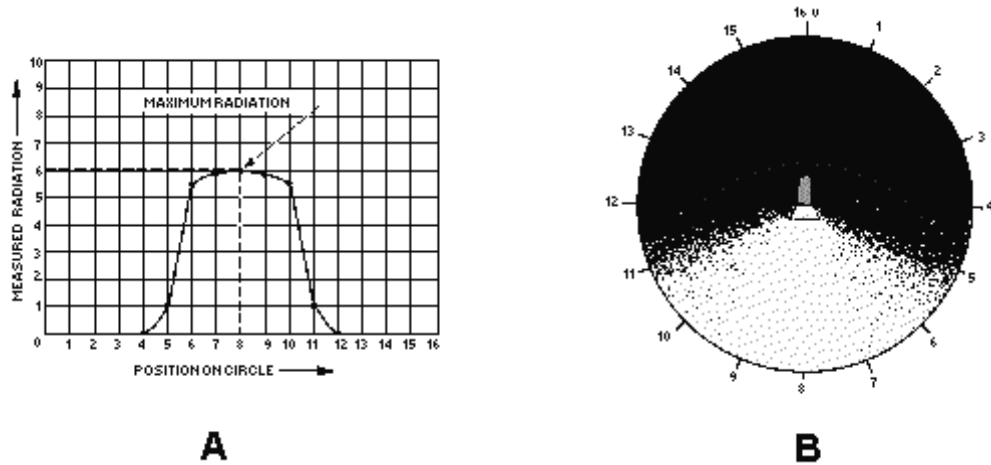

A **LOBE** is the area of a radiation pattern that is covered by radiation.

A **NULL** is the area of a radiation pattern that has minimum radiation.

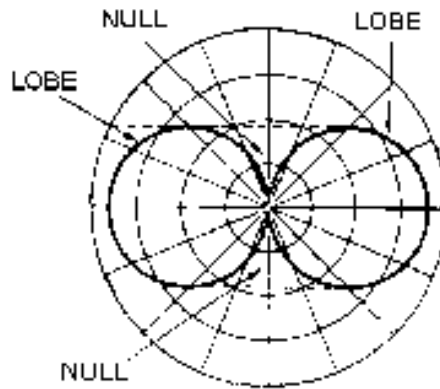

ANTENNA LOADING is the method used to change the electrical length of an antenna. This keeps the antenna in resonance with the applied frequency. It is accomplished by inserting a variable inductor or capacitor in series with the antenna.

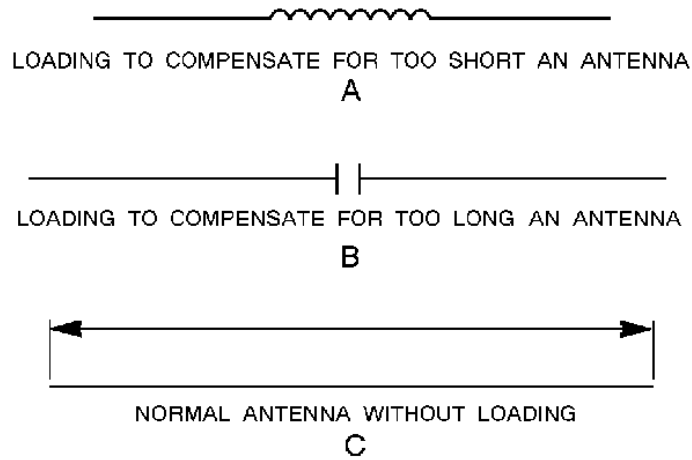

A **HALF-WAVE ANTENNA (Hertz)** consists of two lengths of rod or tubing, each a quarter-wave long at a certain frequency, which radiates a doughnut pattern.

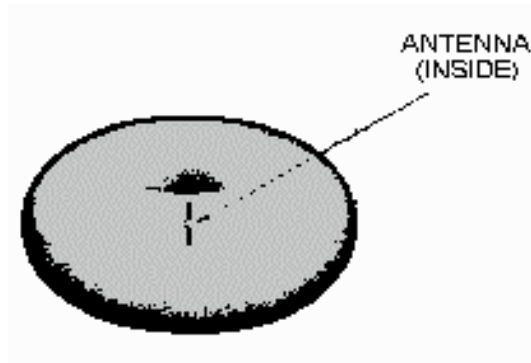

A **QUARTER-WAVE ANTENNA (Marconi)** is a half-wave antenna cut in half with one end grounded. The ground furnishes the missing half of the antenna.

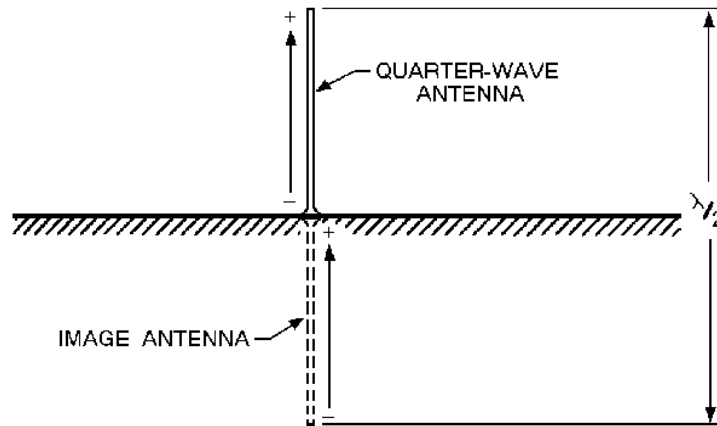

The **GROUND SCREEN** and the **COUNTERPOISE** are used to reduce losses caused by the ground in the immediate vicinity of the antenna. The ground screen is buried below the surface of the earth. The counterpoise is installed above the ground.

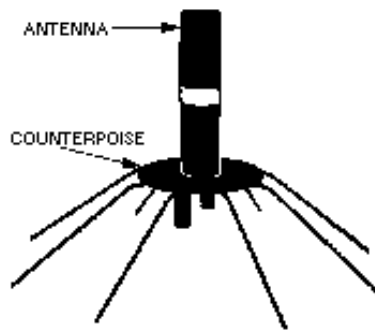
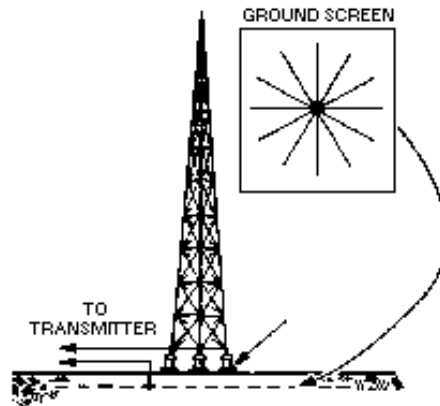

The **FOLDED DIPOLE** consists of a dipole radiator, which is connected in parallel at its ends to a half-wave radiator.

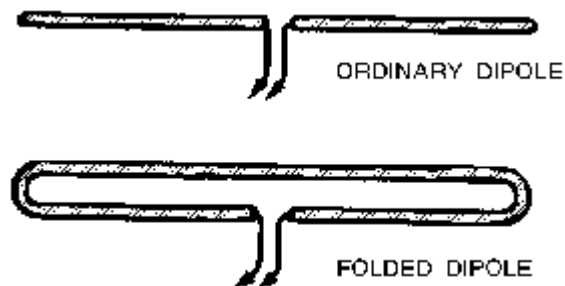

AN **ARRAY** is a combination of half-wave elements operating together as a single antenna. It provides more gain and greater directivity than single element antennas.

A **DRIVEN ARRAY** derives its power directly from the source.

A **PARASITIC ARRAY** derives its power by coupling the energy from other elements of the antenna.

The **BIDIRECTIONAL ARRAY** radiates energy equally in two opposing directions.

The **UNIDIRECTIONAL ARRAY** radiates energy efficiently in a single direction.

The **COLLINEAR ARRAY** has elements in a straight line. Maximum radiation occurs at right angles to this line.

The **BROADSIDE ARRAY** has elements parallel and in the same plane. Maximum radiation develops in the plane at right angles to the plane of the elements.

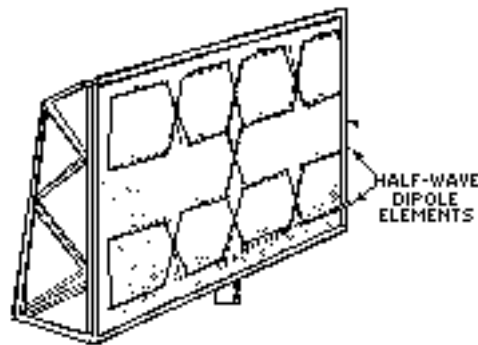

The **END-FIRE ARRAY** has elements parallel to each other and in the same plane. Maximum radiation occurs along the axis of the array.

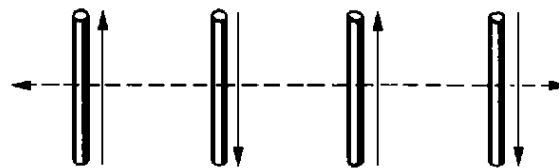

A. TOP VIEW OF ARRAY

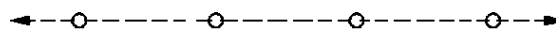

B. SIDE VIEW OF ARRAY

MATCHING STUBS are used between elements to maintain current in the proper phase.

The **GAIN OF A COLLINEAR ANTENNA** is greatest when the elements are spaced from 0.4 to 0.5 wavelength apart or when the number of elements is increased.

The **OPTIMUM GAIN OF A BROADSIDE ARRAY** is obtained when the elements are spaced 0.65 wavelength apart.

A **PARASITIC ARRAY** consists of one or more parasitic elements with a driven element. The amount of power gain and directivity depends on the lengths of the parasitic elements and the spacing between them.

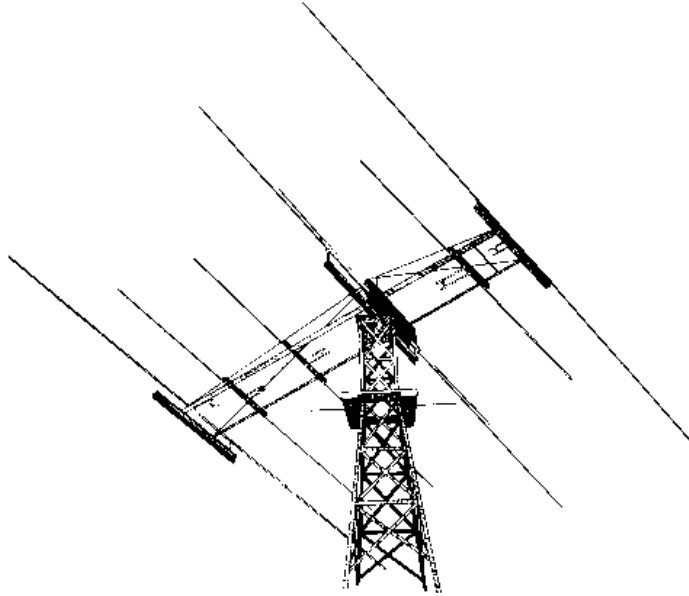

MULTIELEMENT ARRAYS, such as the YAGI, have a narrow frequency response as well as a narrow beamwidth.

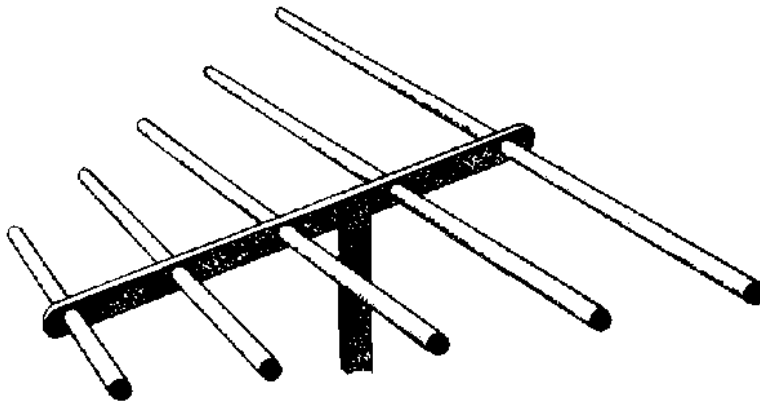

A **LONG-WIRE ANTENNA** is an antenna that is a wavelength or more long at the operating frequency. These antennas have directive patterns that are sharp in both the horizontal and vertical planes.

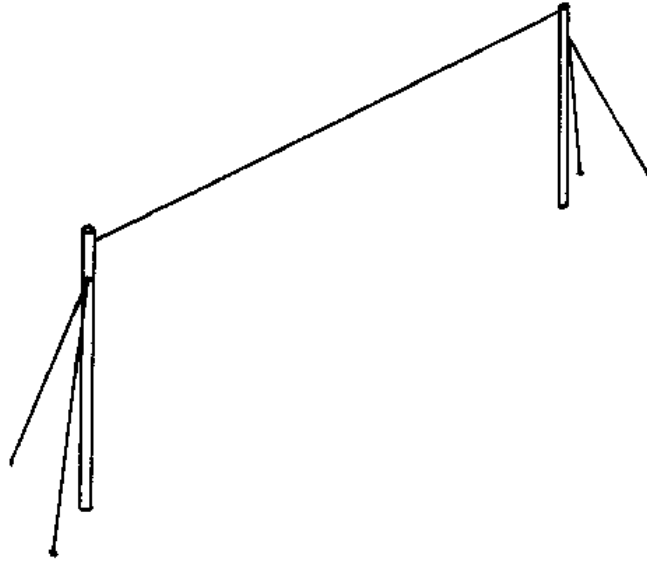

BEVERAGE ANTENNAS consist of a single wire that is two or more wavelengths long.

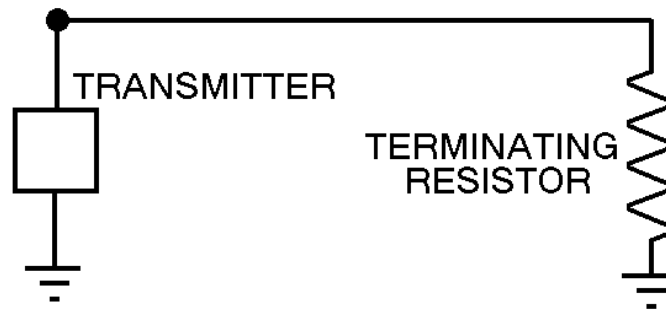

A **V ANTENNA** is a bi-directional antenna consisting of two horizontal, long wires arranged to form a V.

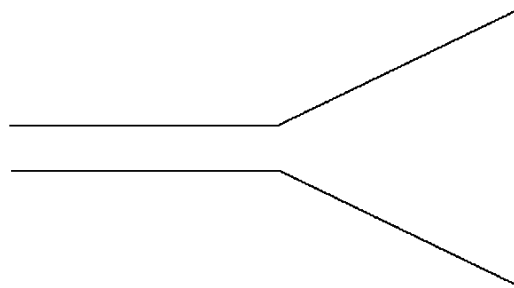

The **RHOMBIC ANTENNA** uses four conductors joined to form a rhombus shape. This antenna has a wide frequency range, is easy to construct and maintain, and is noncritical as far as operation and adjustment are concerned.

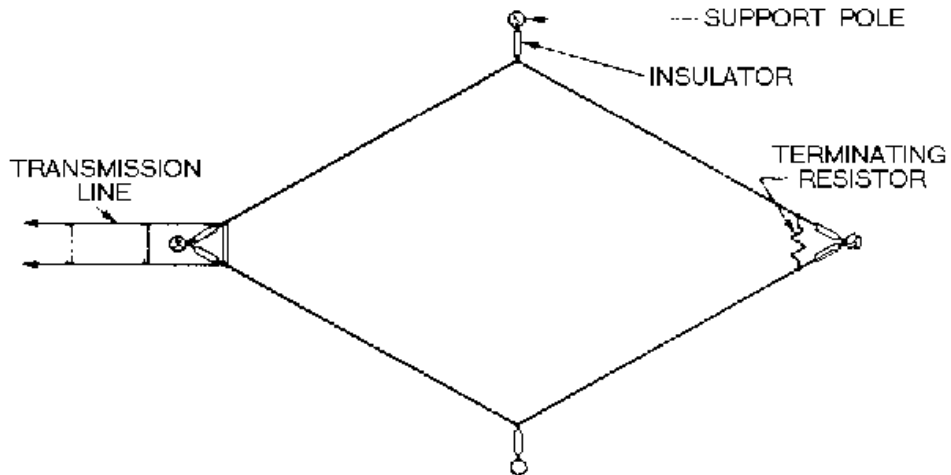

The **TURNSTILE ANTENNA** consists of two horizontal, half-wire antennas mounted at right angles to each other.

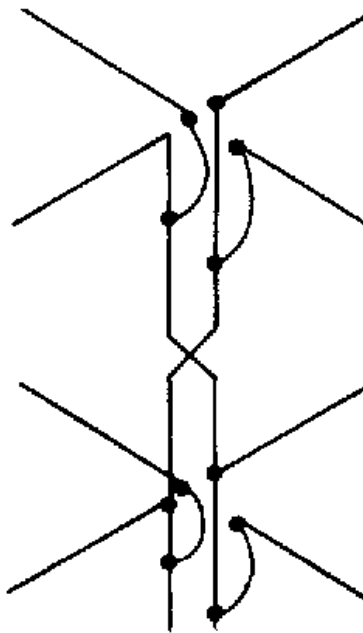

ANSWERS TO QUESTIONS Q1. THROUGH Q48.

- A1. *Half-wave (Hertz) and quarter-wave (Marconi).*
- A2. *Coupling device, feeder, and antenna.*
- A3. *Frequency of operation of the transmitter, amount of power to be radiated, and general direction of the receiving set.*

- A4. One-half the wavelength.*
- A5. Current and voltage loops.*
- A6. Current and voltage nodes.*
- A7. Reciprocity of antennas.*
- A8. Electric (E) field.*
- A9. Circular polarization.*
- A10. Vertical polarization.*
- A11. Less interference is experienced by man-made noise sources.*
- A12. Vertical polarization.*
- A13. 73 ohms.*
- A14. Anisotropic radiator.*
- A15. Isotropic radiator.*
- A16. Anisotropic radiator.*
- A17. Dipole, doublet and Hertz.*
- A18. Nondirectional.*
- A19. Vertical plane.*
- A20. The pattern would flatten.*
- A21. To connect one end through a capacitor to the final output stage of the transmitter.*
- A22. A circular radiation pattern in the horizontal plane, or same as a half wave.*
- A23. It is composed of a series of conductors arranged in a radial pattern and buried 1 to 2 feet below the ground.*
- A24. Nine times the feed-point impedance.*
- A25. Folded dipole.*
- A26. To produce desired phase relationship between connected elements.*
- A27. Major lobes have the greatest amount of radiation.*
- A28. Four.*
- A29. As more elements are added, an unbalanced condition in the system occurs which impairs efficiency.*
- A30. By increasing the lengths of the elements of the array.*

- A31. *Directivity increases.*
- A32. *Lower radiation resistance.*
- A33. *Parallel and in the same plane.*
- A34. *They sharpen.*
- A35. *Extremely low radiation resistance, confined to one frequency, and affected by atmospheric conditions.*
- A36. *Along the major axis*
- A37. *Symmetrically.*
- A38. *Length of the parasitic element (tuning) and spacing between the parasitic and driven elements.*
- A39. *Increased gain and directivity.*
- A40. *Rotary array.*
- A41. *Their adjustment is critical and they do not operate over a wide frequency range.*
- A42. *Increased gain.*
- A43. *Multielement parasitic array.*
- A44. *One-half wavelength.*
- A45. *Wave antenna.*
- A46. *Opposite.*
- A47. *It requires a large antenna site.*
- A48. *For omnidirectional vhf communications.*

APPENDIX I

GLOSSARY

- ABSORPTION**—(1) Absorbing light waves. Does not allow any reflection or refraction.
(2) Atmospheric absorption of rf energy with no reflection or refraction (adversely affects long distance communications).
- ACOUSTICS**—The science of sound.
- AMPLITUDE**—The portion of a cycle measured from a reference line to a maximum value above (or to a maximum value below) the line.
- ANGLE OF INCIDENCE**—The angle between the incident wave and the normal.
- ANGLE OF REFLECTION**—The angle between the reflected wave and the normal.
- ANGLE OF REFRACTION**—The angle between the normal and the path of a wave through the second medium.
- ANGSTROM UNIT**—The unit used to define the wavelength of light waves.
- ANISOTROPIC**—The property of a radiator to emit strong radiation in one direction.
- ANTENNA**—A conductor or set of conductors used either to radiate rf energy into space or to collect rf energy from space.
- ARRAY OF ARRAYS**—Same as COMBINATION ARRAY.
- BAY**—Part of an antenna array.
- BEVERAGE ANTENNA**—A horizontal, longwire antenna designed for reception and transmission of low-frequency, vertically polarized ground waves.
- BIDIRECTIONAL ARRAY**—An array that radiates in opposite directions along the line of maximum radiation.
- BROADSIDE ARRAY**—An array in which the direction of maximum radiation is perpendicular to the plane containing the elements.
- CENTER-FEED METHOD**—Connecting the center of an antenna to a transmission line, which is then connected to the final (output) stage of the transmitter.
- CHARACTERISTIC IMPEDANCE**—The ratio of voltage to current at any given point on a transmission line. Represented by a value of impedance.
- COAXIAL LINE**—A type of transmission line that contains two concentric conductors.
- COLLINEAR ARRAY**—An array with all the elements in a straight line. Maximum radiation is perpendicular to the axis of the elements.
- COMBINATION ARRAY**—An array system that uses the characteristics of more than one array.

COMPLEMENTARY (SECONDARY) COLORS OF LIGHT—The colors of light produced when two of the primaries are mixed in overlapping beams of light. The complementary colors of light are magenta, yellow, and cyan.

COMPLEX WAVE—A wave produced by combining two or more pure tones at the same time.

COMPRESSION WAVES—Longitudinal waves that have been compressed (made more dense) as they move away from the source.

CONDUCTANCE—The opposite of resistance in transmission lines. The minute amount of resistance that is present in the insulator of a transmission line.

CONNECTED ARRAY—Another term for DRIVEN ARRAY.

COPPER LOSSES—The I^2R loss in a conductor caused by the current flow through the resistance of the conductor.

CORNER-REFLECTOR ANTENNA—A half-wave antenna with a reflector consisting of two flat metal surfaces meeting at an angle behind the radiator.

COUNTERPOISE—A network of wire that is connected to a quarter-wave antenna at one end and provides the equivalent of an additional 1/4 wavelength.

COUPLING DEVICE—A coupling coil that connects the transmitter to the feeder.

CREST (TOP)—The peak of the positive alternation (maximum value above the line) of a wave.

CRITICAL ANGLE—The maximum angle at which radio waves can be transmitted and still be refracted back to earth.

CRITICAL FREQUENCY—The maximum frequency at which a radio wave can be transmitted vertically and still be refracted back to earth.

CURRENT-FEED METHOD—Same as CENTER-FEED METHOD.

CURRENT STANDING-WAVE RATIO (ISWR)—The ratio of maximum to minimum current along a transmission line.

CYCLE—One complete alternation of a sine wave that has a maximum value above and a maximum value below the reference line.

DAMPING—Reduction of energy by absorption.

DENSITY—(1) The compactness of a substance. (2) Mass per unit volume.

DETECTOR—The device that responds to a wave or disturbance.

DIELECTRIC HEATING—The heating of an insulating material by placing it in a high frequency electric field.

DIELECTRIC LOSSES—The losses resulting from the heating effect on the dielectric material between conductors.

DIFFRACTION—The bending of the paths of waves when the waves meet some form of obstruction.

DIFFUSION—The scattering of reflected light waves (beams) from an object, such as white paper.

DIPOLE—A common type of half-wave antenna made from a straight piece of wire cut in half. Each half operates at a quarter wavelength of the output.

DIRECTIONAL—Radiation that varies with direction.

DIRECTOR—The parasitic element of an array that reinforces energy coming from the driver toward itself.

DIRECTIVITY—The property of an array that causes more radiation to take place in certain directions than in others.

DISPERSION—The refraction of light waves that causes the different frequencies to bend at slightly different angles.

DISTRIBUTED CONSTANTS—The constants of inductance, capacitance, and resistance in a transmission line. The constants are spread along the entire length of the line and cannot be distinguished separately.

DOPPLER EFFECT—The apparent change in frequency or pitch when a sound source moves either toward or away from a listener.

DOUBLET—Another name for the dipole antenna.

DRIVEN ARRAY—An array in which all of the elements are driven.

DRIVEN ELEMENT—An element of an antenna (transmitting or receiving) that is connected directly to the transmission line.

ECHO—The reflection of the original sound wave as it bounces off a distant surface.

ELASTICITY—The ability of a substance to return to its original state.

ELECTROMAGNETIC FIELD—The combination of an electric (E) field and a magnetic (H) field.

ELECTROMAGNETIC INTERFERENCE—Man-made or natural interference that degrades the quality of reception of radio waves.

ELECTROMAGNETIC RADIATION—The radiation of radio waves into space.

ELECTRIC (E) FIELD—The field produced as a result of a voltage charge on a conductor or antenna.

ELEMENT—A part of an antenna that can be either an active radiator or a parasitic radiator.

END-FEED METHOD—Connecting one end of an antenna through a capacitor to the final output stage of a transmitter.

END-FIRE ARRAY—An array in which the direction of radiation is parallel to the axis of the array.

FADING—Variations in signal strength by atmospheric conditions.

FEEDER—A transmission line that carries energy to the antenna.

FLAT LINE—A transmission line that has no standing waves. This line requires no special tuning device to transfer maximum power.

FLEXIBLE COAXIAL LINE—A coaxial line made with a flexible inner conductor insulated from the outer conductor by a solid, continuous insulating material.

FOLDED DIPOLE—An ordinary half-wave antenna (dipole) that has one or more additional conductors connected across the ends parallel to each other.

FOUR-ELEMENT ARRAY—An array with three parasitic elements and one driven element.

FREE-SPACE LOSS—The loss of energy of a radio wave because of the spreading of the wavefront as it travels from the transmitter.

FREQUENCY—The number of cycles that occur in one second. Usually expressed in hertz.

FREQUENCY DIVERSITY—Transmitting (and receiving) of radio waves on two different frequencies simultaneously.

FRONT-TO-BACK RATIO—The ratio of the energy radiated in the principal direction to the energy radiated in the opposite direction.

FUNDAMENTAL FREQUENCY—The basic frequency or first harmonic frequency.

GAIN—The ratio between the amount of energy propagated from an antenna that is directional to the energy from the same antenna that would be propagated if the antenna were not directional.

GENERATOR END—See INPUT END.

GROUND PLANE—The portion of a groundplane antenna that acts as ground.

GROUND-PLANE ANTENNA—A type of antenna that uses a ground plane as a simulated ground to produce low-angle radiation.

GROUND REFLECTION LOSS—The loss of rf energy each time a radio wave is reflected from the Earth's surface.

GROUND SCREEN—A series of conductors buried below the surface of the earth and arranged in a radial pattern. Used to reduce losses in the ground.

GROUND WAVES—Radio waves that travel near the surface of the Earth.

HALF-WAVE DIPOLE ANTENNA—An antenna consisting of two rods ($1/4$ wavelength each) in a straight line, that radiates electromagnetic energy.

HARMONIC—A frequency that is a whole number multiple of a smaller base frequency.

HERTZ ANTENNA—A half-wave antenna installed some distance above ground and positioned either vertically or horizontally.

HORIZONTAL AXIS—On a graph, the straight line axis plotted from left to right.

HORIZONTAL PATTERN—The part of a radiation pattern that is radiated in all directions along the horizontal plane.

HORIZONTALLY POLARIZED—Waves that are radiated with their E field component parallel to the Earth's surface.

INCIDENT WAVE—(1) The wave that strikes the surface of a medium. (2) The wave that travels from the sending end to the receiving end of a transmission line.

INDUCTION FIELD—The electromagnetic field produced about an antenna when current and voltage are present on the same antenna.

INDUCTION LOSSES—The losses that occur when the electromagnetic field around a conductor cuts through a nearby metallic object and induces a current into that object.

INFRASONIC (SUBSONIC)—Sounds below 15 hertz.

INPUT END—The end of a two-wire transmission line that is connected to a source.

INPUT IMPEDANCE—The impedance presented to the transmitter by the transmission line and its load.

INTENSITY (OF SOUND)—The measurement of the amplitude of sound energy. Sometimes mistakenly called loudness.

INTERCEPT—The point where two lines drawn on a graph cross each other.

INTERFERENCE—Any disturbance that produces an undesirable response or degrades a wave.

IONOSPHERE—The most important region of the atmosphere extending from 31 miles to 250 miles above the earth. Contains four cloud-like layers that affect radio waves.

IONOSPHERIC STORMS—Disturbances in the earth's magnetic field that make communications practical only at lower frequencies.

IONIZATION—The process of upsetting electrical neutrality.

ISOTROPIC RADIATION—The radiation of energy equally in all directions.

LEAKAGE CURRENT—The small amount of current that flows between the conductors of a transmission line through the dielectric.

LIGHT RAYS—Straight lines that represent light waves emitting from a source.

LOAD END—See OUTPUT END.

LOADING—See LUMPED-IMPEDANCE TUNING.

LOBE—An area of a radiation pattern plotted on a polar-coordinate graph that represents maximum radiation.

LONG-WIRE ANTENNA—An antenna that is a wavelength or more long at its operating frequency.

LONGITUDINAL WAVES—Waves in which the disturbance (back and forth motion) takes place in the direction of propagation. Sometimes called compression waves.

LOOP—The curves of a standing wave or antenna that represent amplitude of current or voltage.

LOWEST USABLE FREQUENCY—The minimum operating frequency that can be used for communications between two points.

LUMPED CONSTANTS—The properties of inductance, capacitance, and resistance in a transmission line.

LUMPED-IMPEDANCE TUNING—The insertion of an inductor or capacitor in series with an antenna to lengthen or shorten the antenna electrically.

MAGNETIC (H) FIELD—The field produced when current flows through a conductor or antenna.

MAJOR LOBE—The lobe in which the greatest amount of radiation occurs.

MARCONI ANTENNA—A quarter-wave antenna oriented perpendicular to the earth and operated with one end grounded.

MAXIMUM USABLE FREQUENCY—Maximum frequency that can be used for communications between two locations for a given time of day and a given angle of incidence.

MEDIUM—The substance through which a wave travels from one point to the next. Air, water, wood, etc., are examples of a medium.

MINOR LOBE—The lobe in which the radiation intensity is less than a major lobe.

MULTIELEMENT ARRAY—An array consisting of one or more arrays and classified as to directivity.

MULTIELEMENT PARASITIC ARRAY—An array that contains two or more parasitic elements and a driven element.

MULTIPATH—The multiple paths a radio wave may follow between transmitter and receiver.

NATURAL HORIZON—The line-of-sight horizon.

NEGATIVE ALTERNATION—The portion of a sine wave below the reference line.

NODE—The fixed minimum points of voltage or current on a standing wave or antenna.

NOISE (OF SOUND)—An unwanted disturbance caused by spurious waves that originate from man-made or natural sources.

NONDIRECTIONAL—See OMNIDIRECTIONAL.

NONLUMINOUS BODIES—Objects that either reflect or diffuse light that falls upon them.

NONRESONANT LINE—A transmission line that has no standing waves of current or voltage.

NORMAL—The imaginary line perpendicular to the point at which the incident wave strikes the reflecting surface. Also called the perpendicular.

NULL—On a polar-coordinate graph, the area that represents minimum or 0 radiation.

OMNIDIRECTIONAL—Transmitting in all directions.

OPAQUE—A type of substance that does not transmit any light rays.

OPEN-ENDED LINE—A transmission line that has an infinitely large terminating impedance.

OPTIMUM WORKING FREQUENCY—The most practical operating frequency that can be used with the least amount of problems; roughly 85 percent of the maximum usable frequency.

ORIGIN—The point on a graph where the vertical and horizontal axes cross each other.

OUTPUT END—The end of a transmission line that is opposite the source.

OUTPUT IMPEDANCE—The impedance presented to the load by the transmission line and its source.

PARALLEL RESONANT CIRCUIT—A circuit that acts as a high impedance at resonance.

PARALLEL-WIRE—A type of transmission line consisting of two parallel wires.

PARASITIC ARRAY—An array that has one or more parasitic elements.

PARASITIC ELEMENT—The passive element of an antenna array that is connected to neither the transmission line nor the driven element.

PERIOD—The amount of time required for completion of one full cycle.

PITCH—A term used to describe the frequency of a sound heard by the human ear.

PLANE OF POLARIZATION—The plane (vertical or horizontal) with respect to the earth in which the E field propagates.

POINT OF ZERO DISPLACEMENT—See REFERENCE LINE.

POLAR-COORDINATE GRAPH—A graph whose axes consist of a series of circles with a common center and a rotating radius extending from the center of the concentric circles.

POSITIVE ALTERNATION—The portion of a sine wave above the reference line.

POWER LOSS—The heat loss in a conductor as current flows through it.

POWER STANDING-WAVE RATIO (PSWR)—The ratio of the square of the maximum and minimum voltages of a transmission line.

PRIMARY COLORS (OF LIGHT)—The three primary colors of light (red, green, and blue), from which all other colors may be derived.

PRISM—A triangular-shaped glass that refracts and disperses light waves into component wavelengths.

PROPAGATION—Waves traveling through a medium.

QUALITY (OF SOUND)—The factor that distinguishes tones of pitch and loudness.

QUARTER-WAVE ANTENNA—Same as the Marconi antenna.

RADIATION FIELD—The electromagnetic field that detaches itself from an antenna and travels through space.

RADIATION LOSSES—The losses that occur when magnetic lines of force about a conductor are projected into space as radiation and are not returned to the conductor as the cycle alternates.

RADIATION PATTERN—A plot of the radiated energy from an antenna.

RADIATION RESISTANCE—The resistance, which if inserted in place of an antenna, would consume the same amount of power as that radiated by the antenna.

RADIO FREQUENCIES—Electromagnetic frequencies that fall between 3 kilohertz and 300 gigahertz and are used for radio communications.

RADIO HORIZON—The boundary beyond the natural horizon in which radio waves cannot be propagated over the earth's surface.

RADIO WAVE—(1) A form of radiant energy that can neither be seen nor felt. (2) An electromagnetic wave generated by a transmitter.

RAREFIED WAVE—A longitudinal wave that has been expanded or rarefied (made less dense) as it moves away from the source.

RECEIVER—The object that responds to a wave or disturbance. Same as detector.

RECEIVING ANTENNA—The device used to pick up an rf signal from space.

RECEIVING END—See OUTPUT END.

RECIPROCITY—The property of interchangeability of the same antenna for transmitting and receiving.

RECTANGULAR-COORDINATE GRAPH—A graph in which straight-line axes (horizontal and vertical) are perpendicular.

REFERENCE LINE—The position a particle of matter would occupy if it were not disturbed by wave motion.

REFLECTED WAVE—(1) The wave that reflects back from a medium. (2) Waves traveling from the load back to the generator on a transmission line. (3) The wave moving back to the sending end of a transmission line after reflection has occurred.

REFLECTION WAVES—Waves that are neither transmitted nor absorbed, but are reflected from the surface of the medium they encounter.

REFLECTOR—The parasitic element of an array that causes maximum energy radiation in a direction toward the driven element.

REFRACTION—The changing of direction as a wave leaves one medium and enters another medium of a different density.

RERADIATION—The reception and retransmission of radio waves caused by turbulence in the troposphere.

RESONANCE—The condition produced when the frequency of vibrations are the same as the natural frequency (of a cavity). The vibrations reinforce each other.

RESONANT LINE—A transmission line that has standing waves of current and voltage.

REST POSITION—See REFERENCE LINE.

REVERBERATION—The multiple reflections of sound waves.

RHOMBIC ANTENNA—A diamond-shaped antenna used widely for long-distance, high-frequency transmission and reception.

RIGID COAXIAL LINE—A coaxial line consisting of a central, insulated wire (inner conductor) mounted inside a tubular outer conductor.

SCATTER ANGLE—The angle at which the receiving antenna must be aimed to capture the scattered energy of tropospheric scatter.

SELF-INDUCTION—The phenomenon caused by the expanding and collapsing fields of an electron which encircles other electrons and retards the movement of the encircled electrons.

SELF-LUMINOUS BODIES—Objects that produce their own light.

SENDING END—See INPUT END.

SERIES RESONANT CIRCUIT—A circuit that acts as a low impedance at resonance.

SHIELDED PAIR—A line consisting of parallel conductors separated from each other and surrounded by a solid dielectric.

SHORT-CIRCUITED LINE—A transmission line that has a terminating impedance equal to 0.

SINK—See OUTPUT END.

SKIN EFFECT—The flow of ac current near the surface of a conductor at rf frequencies.

SKIP DISTANCE—The distance from a transmitter to the point where the sky wave is first returned to earth.

SKIP ZONE—A zone of silence between the point where the ground wave becomes too weak for reception and the point where the sky wave is first returned to earth.

SKY WAVES—Radio waves reflected back to earth from the ionosphere.

SONIC—Pertaining to sounds capable of being heard by the human ear.

SOURCE—(1) The object that produces waves or disturbance. (2) The name given to the end of a two-wire transmission line that is connected to a source.

SPACE DIVERSITY—Reception of radio waves by two or more antennas spaced some distance apart.

SPACE WAVE—A radio wave that travels directly from the transmitter to the receiver and remains in the troposphere.

SPECTRUM—(1) The entire range of electromagnetic waves. (2) **VISIBLE**. The range of electromagnetic waves that stimulate the sense of sight. (3) **ELECTROMAGNETIC**. The entire range of electromagnetic waves arranged in order of their frequencies.

SPORADIC E LAYER—Irregular cloud-like patches of unusually high ionization. Often forms at heights near the normal E layer.

SPREADER—Insulator used with transmission lines and antennas to keep the parallel wires separated.

STANDING WAVE—The distribution of voltage and current formed by the incident and reflected waves which have minimum and maximum points on a resultant wave that appears to stand still.

STANDING-WAVE RATIO (SWR)—The ratio of the maximum (voltage, current) to the minimum (voltage, current) of a transmission line. Measures the perfection of the termination of the line.

STRATOSPHERE—Located between the troposphere and the ionosphere. Has little effect on radio waves.

STUB—Short section of a transmission line used to match the impedance of a transmission line to an antenna. Can also be used to produce desired phase relationships between connected elements of an antenna.

SUDDEN IONOSPHERIC DISTURBANCE—An irregular ionospheric disturbance that can totally blank out hf radio communications.

SUPERSONIC—Speed greater than the speed of sound.

SURFACE WAVE—A radio wave that travels along the contours of the earth, thereby being highly attenuated.

TEMPERATURE INVERSION—The condition in which warm air is formed above a layer of cool air that is near the earth's surface.

THREE-ELEMENT ARRAY—An array with two parasitic elements (reflector and director) and a driven element.

TONES—Musical sounds.

TRANSLUCENT—A type of substance, such as frosted glass, through which some light rays can pass but through which objects cannot be seen clearly.

TRANSMISSION LINE—A device designed to guide electrical energy from one point to another.

TRANSMITTING ANTENNA—The device used to send the transmitted signal energy into space.

TRANSPARENT—A type of substance, such as glass, that transmits almost all of the light waves that fall upon it.

TRANSMISSION MEDIUMS—The various types of lines and waveguides used as transmission lines.

TRANSMITTER END—See INPUT END.

TRANSVERSE WAVE MOTION—The up and down motion of a wave as the wave moves outward.

TROPOSPHERE—The portion of the atmosphere closest to the earth's surface, where all weather phenomena take place.

TROPOSPHERIC SCATTER—The propagation of radio waves in the troposphere by means of scatter.

TROUGH (BOTTOM)—The peak of the negative alternation (maximum value below the line).

TUNED LINE—Another name for the resonant line. This line uses tuning devices to eliminate the reactance and to transfer maximum power from the source to the line.

TURNSTILE ANTENNA—A type of antenna used in vhf communications that is omnidirectional and consists of two horizontal half-wave antennas mounted at right angles to each other in the same horizontal plane.

TWISTED PAIR—A line consisting of two insulated wires twisted together to form a flexible line without the use of spacers.

TWO-WIRE OPEN LINE—A parallel line consisting of two wires that are generally spaced from 2 to 6 inches apart by insulating spacers.

TWO-WIRE RIBBON (TWIN LEAD)—A parallel line similar to a two-wire open line except that uniform spacing is assured by embedding the two wires in a low-loss dielectric.

ULTRASONIC—Sounds above 20,000 hertz.

UNIDIRECTIONAL ARRAY—An array that radiates in only one general direction.

UNTUNED LINE—Another name for the flat or nonresonant line.

V ANTENNA—A bi-directional antenna, shaped like a V, which is widely used for communications.

VELOCITY—The rate at which a disturbance travels through a medium.

VERTICAL AXIS—On a graph, the straight line axis oriented from bottom to top.

VERTICAL PATTERN—The part of a radiation pattern that is radiated in the vertical plane.

VERTICALLY POLARIZED—Waves radiated with the E field component perpendicular to the earth's surface.

VOLTAGE-FEED METHOD—Same as END FEED METHOD.

VOLTAGE STANDING-WAVE RATIO (VSWR)—The ratio of maximum to minimum voltage of a transmission line.

WAVE ANTENNA—Same as BEVERAGE ANTENNA.

WAVE MOTION—A recurring disturbance advancing through space with or without the use of a physical medium.

WAVE TRAIN—A continuous series of waves with the same amplitude and wavelength.

WAVEFRONT—A small section of an expanding sphere of electromagnetic radiation, perpendicular to the direction of travel of the energy.

WAVEGUIDE—A hollow metal tube used as a transmission line to guide energy from one point to another.

WAVELENGTH—(1) The distance in space occupied by 1 cycle of a radio wave at any given instant.
(2) The distance a disturbance travels during one period of vibration.

YAGI ANTENNA—A multielement parasitic array. Elements lie in the same plane as those of the end-fire array.

MODULE 10 INDEX

A

Absorption in the ionosphere, 2-24
Absorption of light, 1-31
Acoustics, sound waves, 1-23
Amplitude, wave motion, 1-7
Antennas, 4-1
 antenna characteristics, 4-8
 array antennas, 4-25
 operation of basic antennas, 4-18
 principles of antenna radiation, 4-2
 radiation of electromagnetic energy, 4-6
 rf safety precautions, 4-47
 special antennas, 4-40
Atmospheric propagation, 2-11
 diffraction, 2-13
 reflection, 2-11
 refraction, 2-12

B

Basic antennas, operation of, 4-18
Broadside arrays, 4-31
Bums, if, 4-50

C

Characteristic impedance of a transmission
 line, 3-14
Collinear array, 4-29
Color and frequencies, 1-27
Color and light, 1-28
Comparison of light waves and sound waves,
 1-32
Corner reflector, 4-46
Current and voltage distribution on an antenna,
 4-4
Cycle, wave motion, 1-8

D

Density and velocity of transmission, sound
 waves, 1-22
Determining characteristic impedance, 3-26

Dielectric heating, 4-49
Diffraction, atmospheric propagation, 2-13
Diffraction, wave motion, 1-16
Diffusion of light, 1-31
Directivity, 4-28
Distributed constants, 3-11
Doppler effect, wave motion, 1-16

E

Echo, acoustics, 1-23
Electromagnetic fields, 2-2
 induction field, 2-2
 radiation fields, 2-4
Electromagnetic fields about a transmission
 line, 3-13
Electromagnetic interference (EMI), 2-28
 control of EMI, 2-29
 man-made, 2-28
 natural, 2-29
Electromagnetic spectrum, 1-33
Electromagnetic theory of light, 1-26
Electromagnetic waves, 1-33
 basic antenna, 1-34
 components, 1-35
End-fire array, 4-33

F

Fading, radio wave propagation, 2-26
 multipath, 2-26
 selective, 2-27
Folded dipole, 4-24
Frequency and time, wave motion, 1-9
Frequency selection considerations, radio
 waves, 2-32
 lowest usable frequency, 2-32
 maximum usable frequency, 2-32
 optimum working frequency, 2-33

G

Gain, antenna, 4-9
Glossary, AI-1 to AI-11

Ground-plane antenna, 4-46

H

Half-wave antennas, 4-18

I

Induction field, electromagnetic fields, 2-2

Intensity of sound, 1-20

Interference, acoustics, 1-24

Introduction to transmission lines, 3-1

Ionosphere, 2-15

ionization, 2-19

layers, 2-19

recombination, 2-19

L

Length of a transmission line, 3-8

Light waves, 1-25

comparison of light waves and sound waves, 1-32

electromagnetic theory of light, 1-26

frequencies and color, 1-27

frequencies and wavelengths, 1-27

light and color, 1-28

luminous bodies, 1-28

propagation of light, 1-25

properties of light, 1-28

Loading, antenna, 4-17

Longitudinal waves, wave motion, 1-5

Long-wire antennas, 4-41

Losses in transmission lines, 3-7

Luminous bodies, 1-28

Lumped constants, 3-10

M

Medium, wave motion, 1-6

Mediums, types of transmission, 3-2

Multipath fading, 2-26

N

Noise, acoustics, 1-25

P

Parasitic arrays, 4-35

Phasing, 4-26

Pitch of sound, 1-20

Polarization, 4-9

Polarization, radio waves, 2-10

Precipitation attenuation, 2-34

fog, 2-35

hail, 2-35

rain, 2-34

snow, 2-35

Principles of antenna radiation, 4-2

Principles of transmission lines, 3-1

length of a transmission line, 3-8

losses in transmission lines, 3-7

reflections on a transmission line, 3-28

terminology, 3-2

transmission line theory, 3-10

types of transmission mediums, 3-2

Propagation paths, 2-24

Properties of light, 1-25

Q

Quality of sound, 1-21

Quarter-wave antennas, 4-21

R

Radiation fields, 2-4

Radiation of electromagnetic energy, 4-6

Radiation resistance, 4-12

Radiation types and patterns, 4-12

Radio wave propagation, 2-1

effect of the earth's atmosphere on radio waves, 2-14

electromagnetic fields, 2-2

radio waves, 2-6

tropospheric propagation, 2-36

weather versus propagation, 2-34

Radio wave transmission, 2-15

ground wave, 2-16

sky wave, 2-18

Reciprocity of antennas, 4-8
Reflection, atmospheric propagation, 2-11
Reflection of light, 1-30
Reflection, wave motion, 1-13
Reflections on a transmission line, 3-28
Refraction, acoustics, 1-23
Refraction, atmospheric propagation, 2-12
Refraction in the ionosphere, 2-20
 angle of incidence, 2-22
 density of layer, 2-21
 frequency, 2-21
 skip distance/skip zone, 2-24
Refraction of light, 1-30
Refraction, wave motion, 1-14
Resonance, acoustics, 1-24
Reverberation, acoustics, 1-24
Rhombic antennas, 4-42

S

Safety precautions, if, 4-47
Selective fading, 2-27
Sound waves, 1-17
 acoustics, 1-23
 characteristics, 1-19
 density and velocity of transmission, 1-22
 requirements for sound, 1-18
 terms, 1-19
Special antennas, 4-40
Speed of light, 1-30
Standing waves on a transmission line, 3-43

T

Temperature inversion, 2-35
Terminating a transmission line, 3-38
Termination, 3-43
Terminology, 3-2
Transmission line theory, 3-10
Transmission losses, radio wave propagation, 2-27
 freespace loss, 2-28
 ground reflection loss, 2-28

Transmission mediums, types of, 3-2
Transverse waves, 1-5
Tropospheric propagation, 2-36
 application of tropospheric scatter, 2-38
 tropospheric scattering, 2-37
Turnstile antenna, 4-45

V

V antennas, 4-41
Variations in the ionosphere, 2-29
 irregular variations, 2-30
 regular variations, 2-29
Velocity of wave propagation, 3-24
Voltage change along a transmission line, 3-18

W

Wave motion, principles of, 1-2
 characteristics, 1-9
 in water, 1-3
 longitudinal waves, 1-5
 medium, 1-6
 terms, 1-7
 transverse waves, 1-5
Wave propagation, 1-1
 electromagnetic spectrum, 1-33
 electromagnetic waves, 1-33
 light waves, 1-25
 principles of wave motion, 1-2
 sound waves, 1-17
Wavelength to frequency conversions, radio waves, 2-8
Wavelength, wave motion, 1-8
Wavelengths and frequencies, 1-27
Weather versus propagation, 2-34
 precipitation attenuation, 2-34
 temperature inversion, 2-35
Working aloft, precautions, 4-49

Assignment Questions

Information: The text pages that you are to study are provided at the beginning of the assignment questions.

ASSIGNMENT 1

Textbook assignment: Chapter 1, "Wave Propagation," pages 1-1 through 1-48.

- 1-1. What is the major advantage of the telegraph over earlier methods of communication?
1. Range
 2. Speed
 3. Security
 4. Reliability
- 1-2. The spreading out of radio waves is referred to as propagation and is used in which of the following Navy equipment?
1. Detection
 2. Communication
 3. Radar and navigation
 4. Each of the above
- 1-3. Radio-frequency waves CANNOT be seen for which of the following reasons?
1. Because radio-frequency energy is low powered
 2. Because radio-frequency waves are below the sensitivity range of the human eye
 3. Because the human eye detects only magnetic energy
 4. Because radio-frequency waves are above the sensitivity range of the human eye
- 1-4. Radio waves travel at what speed?
1. Speed of sound
 2. Speed of light
 3. Speed of the Earth's rotation
 4. Speed of the Earth's orbit around the sun
- 1-5. Which of the following types of energy CANNOT be seen, heard, or felt?
1. Radio waves
 2. Sound waves
 3. Heat waves
 4. Light waves
- 1-6. A stone dropped into water creates a series of expanding circles on the surface of the water. This is an example of which of the following types of wave motion?
1. Transverse
 2. Concentric
 3. Longitudinal
 4. Compression
- 1-7. A sound wave that moves back and forth in the direction of propagation is an example of which of the following types of wave motion?
1. Composite
 2. Concentric
 3. Transverse
 4. Longitudinal
- 1-8. Which of the following terms is used for the vehicle through which a wave travels from point to point?
1. Medium
 2. Source
 3. Detector
 4. Receiver
- 1-9. Which of the following is NOT an element necessary to propagate sound?
1. Medium
 2. Source
 3. Detector
 4. Reference

- 1-10. If a wave has a velocity of 4,800 feet per second and a wave-length of 5 feet, what is the frequency of the wave?
1. 9.6 Hz
 2. 96 Hz
 3. 960 Hz
 4. 9,600 Hz

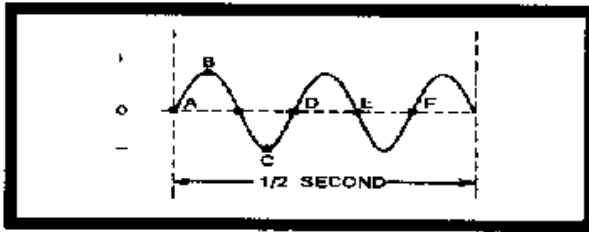

Figure 1-A.—Waveform.

IN ANSWERING QUESTIONS 1-11 THROUGH 1-15, REFER TO FIGURE 1-A.

- 1-11. The waveform in the figure is what type of wave?
1. Sine
 2. Square
 3. Sawtooth
 4. Trapezoidal
- 1-12. The distance between which of the following points represents the completion of a full cycle of alternating current?
1. A to C
 2. B to D
 3. C to E
 4. D to F
- 1-13. The distance between which of the following points represents a full wavelength?
1. A to D
 2. A to E
 3. D to E
 4. E to F

- 1-14. What is the frequency of the wave?
1. 0.5 Hz
 2. 2.5 Hz
 3. 5.0 Hz
 4. 7.5 Hz
- 1-15. What is the period of the wave?
1. 100 milliseconds
 2. 200 milliseconds
 3. 250 milliseconds
 4. 500 milliseconds

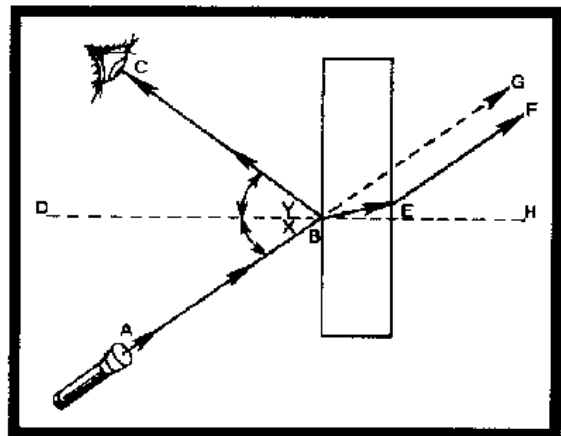

Figure 1-B.—Wave angles.

IN ANSWERING QUESTIONS 1-16 THROUGH 1-19, REFER TO FIGURE 1-B.

- 1-16. What line in the figure indicates the incident wave?
1. A to B
 2. B to E
 3. C to B
 4. D to H
- 1-17. Angle "x" is which of the following angles?
1. Normal
 2. Incidence
 3. Reflection
 4. Refraction

- 1-18. Line E to F represents which of the following waves?
1. Normal
 2. Incident
 3. Refracted
 4. Reflected
- 1-19. Line D to H represents which of the following references?
1. Normal
 2. Perpendicular
 3. Both 1 and 2 above
 4. Reflected line
- 1-20. Which of the following statements about a wave is the law of reflection?
1. The angle of incidence is equal to the refracted wave
 2. The angle of incidence is not equal to the refracted wave
 3. The angle of incidence is equal to the angle of reflection
 4. The angle of incidence is not equal to the angle of reflection
- 1-21. If a wave passes first through a dense medium and then through a less dense medium, which of the following angle-of-refraction conditions exists?
1. The angle of refraction is greater than the angle of incidence
 2. The angle of refraction is less than the angle of incidence
 3. The angle of refraction is equal to the angle of incidence
 4. The wave will pass through in a straight line
- 1-22. The reception of an AM-band radio signal over mountains can be explained by which of the following principles of wave propagation?
1. Reflection
 2. Refraction
 3. Diffraction
 4. Doppler effect
- 1-23. What wave propagation principle accounts for the apparent increase in frequency as a train whistle approaches and the apparent decrease in frequency as it moves away?
1. Refraction
 2. Reflection
 3. Diffraction
 4. Doppler effect
- 1-24. Longitudinal wave disturbances that travel through a medium are known as what type of waves?
1. Air
 2. Sound
 3. Radio
 4. Light
- 1-25. What are the three audible frequency ranges?
1. Subsonic, sonic, and supersonic
 2. Infrasonic, sonic, and ultrasonic
 3. Infrasonic, subsonic, and ultrasonic
 4. Infrasonic, subsonic, and supersonic
- 1-26. If a bell is placed in a jar and the air in the jar is replaced with a gas of a higher density, what is the effect, if any, on the speed of the sound when the bell is rung?
1. The sound stops
 2. The sound travels faster
 3. The sound travels slower
 4. The sound is not affected
- 1-27. Varying which of the following wave characteristics will cause the length of sound waves to vary?
1. Phase
 2. Quality
 3. Amplitude
 4. Frequency

- 1-28. What are the three basic characteristics of sound?
1. Amplitude, intensity, and quality
 2. Amplitude, pitch, and tone
 3. Pitch, intensity, and quality
 4. Pitch, frequency, and quality
- 1-29. If several musical instruments are playing the same note, you should be able to distinguish one instrument from another because of which of the following characteristics of sound?
1. Quality
 2. Overtones
 3. Frequency
 4. Intensity
- 1-30. Through which of the following mediums will sound travel fastest, at the indicated temperature?
1. Air at 68° F
 2. Lead at 20° C
 3. Steel at 32° F
 4. Steel at 20° C
- 1-31. In sound terminology, which of the following terms is the same as a wave reflection?
1. Echo
 2. Image
 3. Acoustics
 4. Refraction
- 1-32. Multiple reflections of sound waves are referred to as
1. noise
 2. acoustics
 3. interference
 4. reverberation
- 1-33. Two out-of-phase waves of the same frequency that are moving through the same medium are said to present which of the following types of interference?
1. Additive
 2. Constructive
 3. Both 1 and 2 above
 4. Subtractive
- 1-34. A cavity that vibrates at its own natural frequency and produces a sound that is louder than at other frequencies is demonstrating which of the following sound characteristics?
1. Noise
 2. Quality
 3. Resonance
 4. Reverberation
- 1-35. Energy in the form of light can be produced through which of the following means?
1. Chemical
 2. Electrical
 3. Mechanical
 4. Each of the above
- 1-36. The scientist, J. C. Maxwell, developed the theory that small packets of electromagnetic energy called photons produce
1. sound
 2. noise
 3. echoes
 4. light
- 1-37. A large volume of light radiating in a given direction is referred to as a
1. ray
 2. beam
 3. shaft
 4. pencil

- 1-38. Which of the following units of measurement is/are used to measure very short wavelengths of light?
1. Angstrom (\AA)
 2. Millimicron
 3. Both 1 and 2 above
 4. Millimeter
- 1-39. What are the primary colors of light?
1. Red, blue, and yellow
 2. Red, blue, and green
 3. Red, violet, and indigo
 4. Blue, green, and violet
- 1-40. What are the secondary colors of light?
1. Orange, yellow, and blue-green
 2. Magenta, yellow, and cyan
 3. Purple, yellow, and black
 4. Red, white, and blue
- 1-41. What causes sunlight to separate into different wavelengths and display a rainbow of colors when passed through a prism?
1. Refraction
 2. Reflection
 3. Dispersion
 4. Diffraction
- 1-42. The sun, gas flames, and electric light filaments are visible because they are
1. opaque
 2. transparent
 3. nonluminous
 4. self-luminous
- 1-43. Substances that transmit almost all of the light waves falling upon them possess which of the following properties?
1. Opaqueness
 2. Transparency
 3. Translucence
 4. Self-lumination
- 1-44. Some substances are able to transmit light waves but objects cannot be seen through them. Which of the following properties does this statement describe?
1. Opaqueness
 2. Transparency
 3. Translucence
 4. Self-lumination
- 1-45. The speed of light depends on the medium through which light travels. For which of the following reasons does light travel through empty space faster than through an object such as glass?
1. Space is less dense than glass
 2. Space is more dense than glass
 3. Glass reflects the light back to the source
 4. Glass refracts the light, causing the light to travel in all directions
- 1-46. If a light wave strikes a sheet of glass at a perpendicular angle, what is the effect, if any, on the light wave?
1. The wave is completely absorbed
 2. The wave is reflected back toward the source
 3. The wave is refracted as it passes through the glass
 4. The wave is unchanged and continues in a straight line
- 1-47. The amount of absorption of the light that strikes an object is determined by the object's
1. color
 2. purity
 3. density
 4. complexity

- 1-48. In a comparison of waves of light and sound as they travel from an air into water, how is the speed of (a) light waves and (b) sound waves affected?
1. (a) Increased (b) increased
 2. (a) Increased (b) decreased
 3. (a) Decreased (b) decreased
 4. (a) Decreased (b) increased
- 1-49. Which of the following waves are NOT a form of electromagnetic energy?
1. Heat waves
 2. Sound waves
 3. Light waves
 4. Radio waves
- 1-50. The electromagnetic spectrum represents the entire range of electromagnetic waves arranged in the order of their
1. color
 2. frequency
 3. visibility
 4. application
- 1-51. Which of the following portions of the frequency spectrum contains the highest frequency?
1. X-ray
 2. Radar
 3. Light
 4. Cosmic
- 1-52. Which of the following electronic devices is used to radiate and/or collect electromagnetic waves?
1. Antenna
 2. Receiver
 3. Transmitter
 4. Transmission line
- 1-53. The electric field and magnetic field combine to form which of the following types of waves?
1. Spherical
 2. Elliptical
 3. Electromagnetic
 4. Each of the above
- 1-54. The magnetic field radiated from an antenna is produced by what electrical property?
1. Voltage
 2. Current
 3. Reactance
 4. Resistance
- 1-55. The electric field radiated from an antenna is produced by what electrical property?
1. Voltage
 2. Current
 3. Reactance
 4. Resistance
- 1-56. Applying rf energy to the elements of an antenna results in what phase relationship between voltage and current?
1. Voltage lags current by 90 degrees
 2. Voltage leads current by 90 degrees
 3. Voltage and current are 180 degrees out of phase
 4. Voltage and current are in phase
- 1-57. What field exists close to the conductor of an antenna and carries the current?
1. Electric
 2. Magnetic
 3. Induction
 4. Radiation

1-58. What field travels through space after being detached from the current-carrying rod of an antenna?

1. Electric
2. Magnetic
3. Induction
4. Radiation

1-59. Electric and magnetic fields on an antenna reach their maximum intensity at which of the following times?

1. When they are a full cycle apart
2. When they are three-quarter cycle apart
3. When they are a half-cycle apart
4. When they are a quarter-cycle apart

ASSIGNMENT 2

Textbook assignment: Chapter 2, "Radio Wave Propagation," pages 2-1 through 2-47.

- 2-1. The induction field is made up of which of the following fields?
1. E field only
 2. H field only
 3. Both E and H fields
- 2-2. After the radiation field leaves an antenna, what is the relationship between the E and H fields with respect to (a) phase and (b) physical displacement in space?
1. (a) In phase (b) 90 degrees
 2. (a) Out of phase (b) 90 degrees
 3. (a) In phase (b) 180 degrees
 4. (a) Out of phase (b) 180 degrees
- 2-3. What is the first harmonic of a radio wave that has a fundamental frequency of 2,000 kHz?
1. 6,000 kHz
 2. 2,000 kHz
 3. 3,000 kHz
 4. 4,000 kHz
- 2-4. In a radio wave with a fundamental frequency of 1.5 kHz, which of the following frequencies is NOT a harmonic?
1. 6,000 kHz
 2. 5,000 kHz
 3. 3,000 kHz
 4. 4,000 kHz
- 2-5. A radio wave with a frequency of 32 kHz is part of which of the following frequency bands?
1. The lf band
 2. The mf band
 3. The hf band
 4. The vhf band
- 2-6. A frequency of 3.5 GHz falls into what rf band?
1. High
 2. Very high
 3. Super high
 4. Extremely high
- 2-7. A radio wavelength expressed as 250 meters may also be expressed as how many feet?
1. 410
 2. 820
 3. 1,230
 4. 1,640
- 2-8. An increase in the frequency of a radio wave will have what effect, if any, on the velocity of the radio wave?
1. Increase
 2. Decrease
 3. None
- 2-9. An increase in frequency of a radio wave will have what effect, if any, on the wavelength of the radio wave?
1. Increase
 2. Decrease
 3. None
- 2-10. What is the frequency, in kiloHertz, of a radio wave that is 40 meters long?
1. 75
 2. 750
 3. 7,500
 4. 75,000

2-11. What is the approximate wavelength, in feet, of a radio wave with a frequency of 5,000 kHz?

1. 197 feet
2. 1,970 feet
3. 19,700 feet
4. 197,000 feet

2-12. The polarity of a radio wave is determined by the orientation of (a) what moving field with respect to (b) what reference?

1. (a) Electric (b) earth
2. (a) Electric (b) antenna
3. (a) Magnetic (b) antenna
4. (a) Magneti (b) earth

2-13. Energy radiated from an antenna is considered horizontally polarized under which of the following conditions?

1. If the wavefront is in the horizontal plane
2. If the magnetic field is in the horizontal plane
3. If the electric field is in the horizontal plane
4. If the induction field is in the horizontal plane

2-14. The ability of a reflecting surface to reflect a specific radio wave depends on which of the following factors?

1. Striking angle
2. Wavelength of the wave
3. Size of the reflecting area
4. All of the above

THIS SPACE LEFT BLANK
INTENTIONALLY.

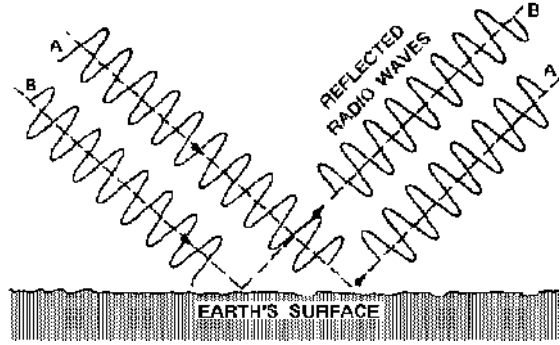

Figure 2-A.—Reflected radio waves.

IN ANSWERING QUESTION 2-15, REFER TO FIGURE 2-A.

2-15. If the two reflected radio waves shown in the figure are received at the same instant at the receiving site, what will be the effect, if any, on signal quality?

1. A stronger signal will be produced
2. A weak or fading signal will be produced
3. The signal will be completely canceled out
4. None

2-16. The bending of a radio wave because of a change in its velocity through a medium is known as

1. refraction
2. reflection
3. deflection
4. diffraction

2-17. Radio communications can be diffracted to exceptionally long distances through the use of (a) what frequency band at (b) what relative power level?

1. (a) Very low frequency (b) Low power
2. (a) Very high frequency (b) Low power
3. (a) Very low frequency (b) High power
4. (a) Very high frequency (b) High power

2-18. Electrically charged particles that affect the propagation of radio waves are found in what atmospheric layer?

1. Troposphere
2. Ionosphere
3. Chronosphere
4. Stratosphere

2-19. Most weather phenomena take place in which of the following region of the atmosphere?

1. Troposphere
2. Ionosphere
3. Chronosphere
4. Stratosphere

2-20. Radio wave propagation has the least effect because of its constancy on which of the following atmospheric layers?

1. Troposphere
2. Ionosphere
3. Chronosphere
4. Stratosphere

2-21. Long range, surface-wave communications are best achieved when the signal is transmitted over seawater with (a) what polarization at (b) what relative frequency?

1. (a) Vertical (b) Low
2. (a) Vertical (b) High
3. (a) Horizontal (b) High
4. (a) Horizontal (b) Low

2-22. The Navy's long-range vlf broadcasts are possible because of the advantages of which of the following types of propagation?

1. Diffraction
2. Ionospheric refraction
3. Repeated reflection and refraction
4. Both 2 and 3 above

2-23. A space wave (a) is primarily a result of refraction in what atmospheric layer and (b) extends approximately what distance beyond the horizon?

1. (a) Ionosphere (b) One-tenth farther
2. (a) Ionosphere (b) One-third farther
3. (a) Troposphere (b) One-third farther
4. (a) Troposphere (b) One-tenth farther

2-24. The signal of a space wave is sometimes significantly reduced at the receiving site because of which of the following interactions?

1. Space-wave refraction
2. Space-wave reflections
3. Ground-wave diffraction
4. Ground-wave reflections

2-25. For long-range communications in the hf band, which of the following types of waves is most satisfactory?

1. Sky wave
2. Space wave
3. Surface wave
4. Reflected ground wave

2-26. Ionization in the atmosphere is produced chiefly by which of the following types of radiation?

1. Alpha radiation
2. Cosmic radiation
3. Infrared radiation
4. Ultraviolet radiation

2-27. Ultraviolet waves of higher frequencies produce ionized layers at what relative altitude(s)?

1. Lower
2. Higher
3. Both 1 and 2 above

- 2-28. The density of ionized layers is normally greatest during which of the following periods?
1. At night
 2. Before sunrise
 3. Between early morning and late afternoon
 4. Between afternoon and sunset
- 2-29. Compared to the other ionospheric layers at higher altitudes, the ionization density of the D layer is
1. about the same
 2. relatively low
 3. relatively high
- 2-30. What two layers in the ionosphere recombine and largely disappear at night?
1. D and F
 2. D and E
 3. E and F2
 4. F1 and F2
- 2-31. For hf-radio communications covering long distances, what is the most important layer of the ionosphere?
1. C
 2. D
 3. E
 4. F
- 2-32. Refraction of a sky wave in the ionosphere is influenced by which of the following factors?
1. Ionospheric density
 2. Frequency of the wave
 3. Angle of incidence of the wave
 4. All of the above
- 2-33. A 10-MHz wave entering the ionosphere at an angle greater than its critical angle will pass through the ionosphere and be lost in space unless which of the following actions is taken?
1. The ground wave is canceled
 2. The frequency of the wave is increased
 3. The frequency of the wave is decreased
 4. The ground wave is reinforced
- 2-34. The distance between the transmitter and the nearest point at which refracted waves return to earth is referred to as the
1. skip distance
 2. return distance
 3. reception distance
 4. ground-wave distance
- 2-35. When ground-wave coverage is LESS than the distance between the transmitter and the nearest point at which the refracted waves return to earth, which of the following reception possibilities should you expect?
1. No sky-wave
 2. Weak ground wave
 3. A zone of silence
 4. Strong ground wave
- 2-36. The greatest amount of absorption takes place in the ionosphere under which of the following conditions?
1. When sky wave intensity is the greatest
 2. When collision of particles is least
 3. When the density of the ionized layer is the greatest
 4. When precipitation is greatest
- 2-37. Which of the following layers provide the greatest amount of absorption to the ionospheric wave?
1. D and E
 2. D and F1
 3. E and F1
 4. F1 and F2

- 2-38. If the signal strength of an incoming signal is reduced for a prolonged period, what type of fading is most likely involved?
1. Selective
 2. Multipath
 3. Absorption
 4. Polarization
- 2-39. Radio waves that arrive at a receiving site along different paths can cause signal fading if these waves have different
1. velocities
 2. amplitudes
 3. phase relationships
 4. modulation percentages
- 2-40. The technique of reducing multipath fading by using several receiving antennas at different locations is known as what type of diversity?
1. Space
 2. Receiver
 3. Frequency
 4. Modulation
- 2-41. The amount of rf energy lost because of ground reflections depends on which of the following factors?
1. Angle of incidence
 2. Ground irregularities
 3. Frequency of the wave
 4. Each of the above
- 2-42. Receiving sites located near industrial areas can expect to have exceptionally large losses in signal quality as a result of which of the following propagation situations?
1. Absorption
 2. Multihop refraction
 3. Natural interference
 4. Man-made interference
- 2-43. Which of the following ionospheric variation causes densities to vary with the axial rotation of the sun?
1. Daily variation
 2. Seasonal variation
 3. 27-day sunspot cycle
 4. 11-year sunspot cycle
- 2-44. Which of the following ionospheric variation causes densities to vary with the position of the earth in its orbit around the sun?
1. Daily variation
 2. Seasonal variation
 3. 27-day sunspot cycle
 4. 11-year sunspot cycle
- 2-45. Which of the following ionospheric variation causes densities to vary with the time of the day?
1. Daily variation
 2. Seasonal variation
 3. 27-day sunspot cycle
 4. 11-year sunspot cycle
- 2-46. What relative range of operating frequencies is required during periods of maximum sunspot activity?
1. Lower
 2. Medium
 3. Higher
- 2-47. What factor significantly affects the frequency of occurrence of the sporadic-E layer?
1. Seasons
 2. Latitude
 3. Weather conditions
 4. Ionospheric storms

- 2-48. What effect can the sporadic-E layer have on the propagation of sky waves?
1. Causes multipath interference
 2. Permits long distance communications at unusually high frequencies
 3. Permits short-distance communications in the normal skip zone
 4. Each of the above
- 2-49. A sudden and intense burst of ultraviolet light is especially disruptive to communications in which of the following frequency bands?
1. Hf
 2. Mf
 3. Lf
 4. Vlf
- 2-50. The density of what ionosphere layer increases because of a violent eruption on the surface of the sun?
1. D
 2. E
 3. F1
 4. F2
- 2-51. Which irregular variation in ionospheric conditions can cause a waiting period of several days before communications return to normal?
1. Sporadic E
 2. Ionospheric storms
 3. Sudden ionospheric disturbance
 4. Each of the above
- 2-52. For a radio wave entering the atmosphere of the earth at a given angle, the highest frequency at which refraction will occur is known by which of the following terms?
1. Usable frequency
 2. Refraction frequency
 3. Maximum usable frequency
 4. Optimum working frequency
- 2-53. The most consistent communications can be expected at which of the following frequencies?
1. Critical frequency
 2. Maximum usable frequency
 3. Maximum working frequency
 4. Optimum working frequency
- 2-54. If the optimum working frequency for a communications link is 4,250 kHz, what is the approximate maximum usable frequency?
1. 4,500 kHz
 2. 5,000 kHz
 3. 5,500 kHz
 4. 6,000 kHz
- 2-55. In determining the success of radio transmission, which of the following factors is the LEAST predictable?
1. Antenna capabilities
 2. Weather conditions along the path of communication
 3. Density of ionized layers
 4. Presence of ionized layers
- 2-56. At frequencies above 100 MHz, the greatest attenuation of rf energy from raindrops is caused by which of the following factors?
1. Ducting
 2. Heat loss
 3. Scattering
 4. Absorption
- 2-57. Under certain conditions, such as ducting, line-of-sight radio waves often propagate for distances far beyond their normal ranges because of which of the following factors?
1. Low cloud masses
 2. Ionospheric storms
 3. Temperature inversions
 4. Frequency fluctuations

- 2-58. When ducting is present in the atmosphere, multihop refraction of line-of-sight transmission can occur because of which of the following factors?
1. Operating frequency of the transmitter
 2. Height of the transmitting antenna
 3. Angle of incidence of the radio wave
 4. Each of the above
- 2-59. A propagation technique used to extend uhf transmission range beyond the horizon uses which of the following propagation characteristics?
1. Ground reflection
 2. Ionospheric scatter
 3. Tropospheric scatter
 4. Atmospheric refraction
- 2-60. Communications by tropospheric scatter can be affected by which of the following conditions?
1. Sunspot activity
 2. Atmospheric conditions
 3. Ionospheric disturbances
 4. All of the above
- 2-61. What effect, if any, does the radiation angle of a transmitting antenna have on the reception of communications by tropospheric scatter?
1. The lower the angle, the weaker the signal
 2. The lower the angle, the stronger the signal
 3. The lower the angle, the more susceptible the signal is to distortion
 4. None
- 2-62. Which of the following descriptions of tropospheric scatter signal reception is NOT true?
1. Receiver signal strength decreases as the turbulence height is increased
 2. The level of reception depends on the number of turbulences causing scatter
 3. The energy received is the portion of the wave reradiated by the turbulence
 4. Increased communications distance enables more turbulence to act on the signal, thereby raising the received signal level
- 2-63. The tropospheric scatter signal is often characterized by very rapid fading caused by which of the following factors?
1. Extreme path lengths
 2. Multipath propagation
 3. Turbulence in the atmosphere
 4. Angle of the transmitted beam
- 2-64. For which of the following communications situations would turbulence in the troposphere scatter transmission?
1. 10 MHz, range 200 miles
 2. 30 MHz, range 800 miles
 3. 50 MHz, range 600 miles
 4. 100 MHz, range 400 miles

ASSIGNMENT 3

Textbook assignment: Chapter 3, "Principles of Transmission Lines," pages 3-1 through 3-58.

- 3-1. A transmission line is designed to perform which of the following functions?
1. Disperse energy in all directions
 2. Detune a transmitter to match the load
 3. Guide electrical energy from point to point
 4. Replace the antenna in a communications system
- 3-2. All transmission lines must have two ends, the input end and the output end. What other name is given to the input end?
1. Sending end
 2. Generator end
 3. Transmitter end
 4. Each of the above
- 3-3. A measurement of the voltage to current ratio (E_{in}/I_{in}) at the input end of a transmission line is called the
1. input-gain rate
 2. input impedance
 3. output impedance
 4. voltage-gain ratio
- 3-4. Which of the following lines is NOT a transmission medium?
1. Load line
 2. Coaxial line
 3. Two-wire line
 4. Twisted-pair line
- 3-5. Electrical power lines are most often made of which of the following types of transmission lines?
1. Twin-lead line
 2. Shielded-pair line
 3. Two-wire open line
 4. Two-wire ribbon line
- 3-6. Uniform capacitance throughout the length of the line is an advantage of which of the following transmission lines?
1. Coaxial line
 2. Twisted pair
 3. Shielded pair
 4. Two-wire open line
- 3-7. What is the primary advantage of a rigid coaxial line?
1. Low radiation losses
 2. Inexpensive construction
 3. Low high-frequency losses
 4. Each of the above
- 3-8. Which of the following wave-guides is seldom used because of its large energy loss characteristics?
1. Metallic
 2. Dielectric
 3. Elliptical
 4. Cylindrical
- 3-9. To some degree, transmission lines always exhibit which of the following types of losses?
1. I^2R
 2. Inductor
 3. Dielectric
 4. Each of the above
- 3-10. Skin effect is classified as which of the following types of loss?
1. Copper
 2. Voltage
 3. Induction
 4. Dielectric

- 3-11. What transmission-line loss is caused by magnetic lines of force not returning to the conductor?
1. Copper
 2. Radiation
 3. Induction
 4. Dielectric
- 3-12. What is the electrical wave-length of 1 cycle if the frequency is 60 hertz?
1. 125,000 meters
 2. 1,250,000 meters
 3. 5,000,000 meters
 4. 20,000,000 meters
- 3-13. A transmission line 10 meters in length is considered to be electrically long at which of the following frequencies?
1. 60 kilohertz
 2. 600 kilohertz
 3. 6 megahertz
 4. 60 megahertz
- 3-14. The conductance value of a transmission line represents which of the following values?
1. Expected value of current flow through the insulation
 2. Expected value of voltage supplied by the transmitter
 3. Value of the lump and distributed constants of the line divided by impedance
 4. Value of the lump and distributed constants of the line divided by impedance
- 3-15. Electrical constants in a transmission line are distributed in which of the following ways?
1. Into a single device
 2. Along the length of the line
 3. According to the thickness of the line
 4. According to the cross-sectional area of the line
- 3-16. Leakage current in a two-wire transmission line is the current that flows through what component?
1. The resistor
 2. The inductor
 3. The insulator
 4. The conductor
- 3-17. Conductance is the reciprocal of what electrical property?
1. Inductance
 2. Resistance
 3. Capacitance
 4. Reciprocity
- 3-18. A transmission line that has current flowing through it has which, if any, of the following fields about it?
1. Electric field only
 2. Magnetic field only
 3. Both electric and magnetic fields
 4. None of the above
- 3-19. Maximum transfer of energy from the source to the transmission line takes place when what impedance relationship exists between the source and the transmission line?
1. When the load impedance equals source impedance
 2. When the load impedance is twice the source impedance
 3. When the load impedance is half the source impedance
 4. When the load impedance is one-fourth the source impedance
- 3-20. The characteristic impedance (Z_0) of a transmission line is calculated by using which of the following ratios?
1. R_s to R_{load} of the line
 2. I_{max} to I_{min} at every point along the line
 3. E to I at every point along the line
 4. E_{in} to E_o of the line

- 3-21. For a given voltage, what determines the amount of current that will flow in a transmission line?
1. Conductance
 2. Spacing of the wires
 3. Diameter of the wires
 4. Characteristic impedance
- 3-22. When the impedance of a transmission line is measured, which of the following values frequently is NOT considered?
1. Inductance
 2. Resistance
 3. Conductance
 4. Capacitance
- 3-23. The characteristic impedance of a long transmission line may be determined by using which of the following methods?
1. Trial and error
 2. Calculating the impedance of the entire line
 3. Calculating the impedances at each end of the line
 4. Adding the impedances of successive short sections
- 3-24. When should lumped values for transmission-line constants be used to calculate characteristic impedance?
1. When the line is short compared to one wavelength
 2. When the line is long compared to one wavelength
 3. When the line is infinitely long
- 3-25. In actual practice, the characteristic impedance of a transmission line is usually within which of the following resistance ranges?
1. 0 to 0.9 ohm
 2. 1 to 49 ohms
 3. 50 to 600 ohms
 4. 601 to 1,000 ohms
- 3-26. The input impedance of a transmission line is affected by which of the following properties?
1. Radiation loss
 2. Series inductance
 3. Parallel capacitance
 4. Each of the above
- 3-27. When a dc voltage is applied to a transmission line and the load absorbs all the energy, what is the resulting relationship between current and voltage?
1. They are in phase with each other
 2. They are equal to Z_0 of the line
 3. They are out of phase with each other
 4. They are evenly distributed along the line
- 3-28. The initial waves that travel from the source to the load of a transmission line are referred to as what type of waves?
1. Incident
 2. Refracted
 3. Reflected
 4. Diffracted
- 3-29. Waves that travel from the output end to the input end of a transmission line are referred to as what type of waves?
1. Incident
 2. Refracted
 3. Reflected
 4. Diffracted

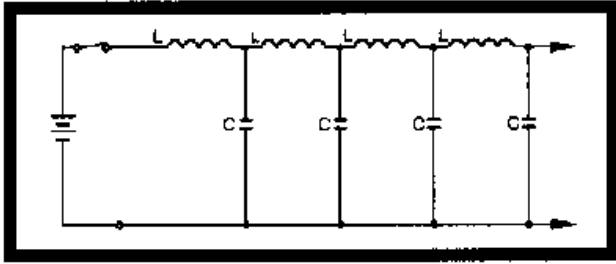

Figure 3-A.—Equivalent infinite transmission line.

IN ANSWERING QUESTION 3-30, REFER TO FIGURE 3-A.

- 3-30. When a dc voltage is applied to the equivalent infinite line in the figure, which of the following conditions occurs along the length of the line?
1. Standing waves of voltage form
 2. Standing waves of current form
 3. Current flows indefinitely
 4. Voltage appears for a short time

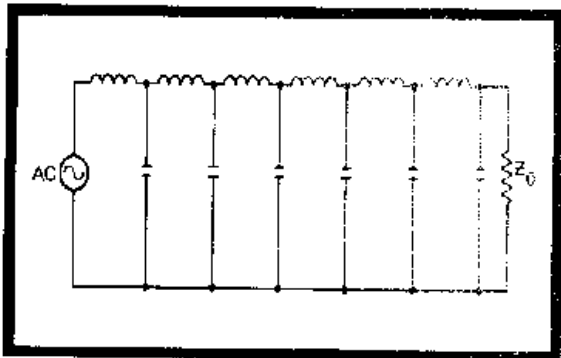

Figure 3-B.—Equivalent transmission line.

IN ANSWERING QUESTION 3-31, REFER TO FIGURE 3-B.

- 3-31. Compared to a dc input, what relative amount of time is required for an ac input voltage to travel the length of the line shown in the circuit?
1. Less
 2. Same
 3. More

- 3-32. The instantaneous voltage on an infinite transmission line can be plotted against time by using which of the following instruments?

1. A wavemeter
2. A multimeter
3. An oscilloscope
4. A spectrum analyzer

- 3-33. On an infinite transmission line with an ac voltage applied, which of the following is an accurate description of the effective voltage distribution along the line?

1. Voltage is 0 at all points
2. Voltage is constant at all points
3. Voltage varies at a sine-wave rate
4. Voltage varies at double the sine-wave rate

- 3-34. The velocity of propagation on a transmission line is controlled by which of the following line characteristics?

1. Conductance
2. Inductance only
3. Capacitance only
4. Capacitance and inductance

- 3-35. The total charge on a transmission line is equal to the current multiplied by which of the following factors?

1. Time
2. Power
3. Voltage
4. Resistance

3-36. With only capacitance and inductance of the line given, the time (T) required for a voltage change to travel down a transmission line can be found by what formula? The characteristic impedance for an infinite transmission line can be figured using which of the following ratios?

1. $T = \sqrt{\frac{L}{C}}$ 3. $T = L + C$

2. $T = \sqrt{LC}$ 4. $T = L - C$

3-37. The characteristic impedance for an infinite transmission line can be figured using which of the following ratios?

1. Input current to velocity
2. Input voltage to input current
3. Input voltage to line resistance
4. Input current to line resistance

3-38. The characteristic impedance of a transmission line can be figured by using which of the following formulas?

1. $Z_0 = \frac{1}{LC}$ 3. $Z_0 = \frac{C}{L}$

2. $Z_0 = \sqrt{LC}$ 4. $Z_0 = \sqrt{\frac{L}{C}}$

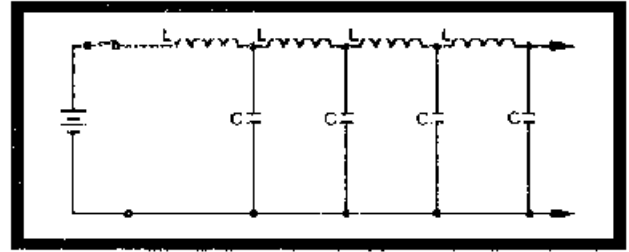

Figure 3-C.—Equivalent transmission line.

IN ANSWERING QUESTIONS 3-39 AND 3-40, REFER TO FIGURE 3-C. ASSUME THAT THE LINE IS 1,200 FEET LONG. A 150-FOOT SECTION IS MEASURED TO DETERMINE L AND C. THE 150-FOOT SECTION HAS AN INDUCTANCE OF 0.36 MILLIHENRIES AND A CAPACITANCE OF 1,000 PICOFARADS.

3-39. What is the characteristic impedance of the line?

1. 400 ohms
2. 600 ohms
3. 800 ohms
4. 900 ohms

3-40. What is the velocity of the wave on the 150-foot section?

1. 210,000,000 fps
2. 225,000,000 fps
3. 250,000,000 fps
4. 275,000,000 fps

3-41. If a transmission line is open-ended, which of the following conditions describes its terminating impedance?

1. Finite
2. Infinitely large
3. Equal to load impedance
4. Equal to source impedance

3-42. When a transmission line is not terminated in its characteristic impedance (Z_0), what happens to the incident energy that is NOT transferred to the load?

1. It is returned along the transmission line
2. It is radiated into space
3. It is absorbed by the line
4. It is converted to heat energy

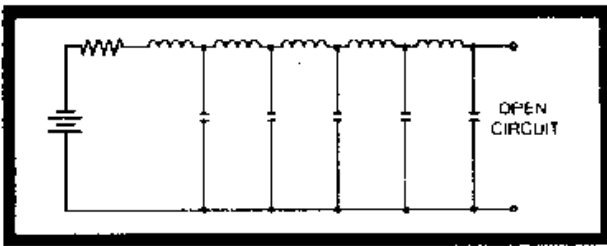

Figure 3-D.—Open-ended transmission line.

IN ANSWERING QUESTIONS 3-43 AND 3-44, REFER TO FIGURE 3-D.

3-43. When the dc voltage reaches the open end of the transmission line in the figure and is reflected, it has which, if any, of the following changes?

1. Increased amplitude
2. Decreased amplitude
3. The opposite polarity
4. None of the above

3-44. When the dc current reaches the open end of the transmission line and is reflected, it has which, if any, of the following changes?

1. Increased amplitude
2. Decreased amplitude
3. The opposite polarity
4. None of the above

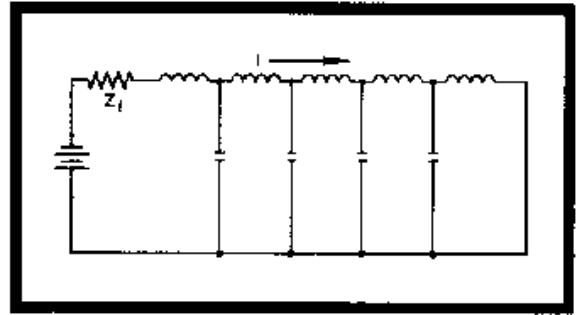

Figure 3-E.—Short-circuited transmission line.

IN ANSWERING QUESTIONS 3-45 AND 3-46, REFER TO FIGURE 3-E.

3-45. When the dc voltage reaches the shorted end of the transmission line, it is reflected. It has which, if any, of the following changes?

1. Increased amplitude
2. Decreased amplitude
3. The opposite polarity
4. None

3-46. When the dc current reaches the shorted end of the transmission line, it is reflected. It has which, if any, of the following changes?

1. Decrease amplitude
2. Increase amplitude
3. Increased polarity
4. None of the above

- 3-47. In an open-ended transmission line with an ac signal applied, what is the phase relationship between the incident and reflected voltage waves?
1. In phase
 2. 45 degrees out of phase
 3. 90 degrees out of phase
 4. 180 degrees out of phase
- 3-48. The resultant of the incident and reflected voltage waves is called the standing wave. Its value is figured by using which of the following procedures?
1. Adding the effective values of the two waveforms
 2. Algebraically adding the instantaneous values of the two waveforms
 3. Algebraically subtracting the instantaneous values of the two waveforms
 4. Taking the square root of the product of the incident and reflected voltages
- 3-49. On an open-ended transmission line that is carrying an ac signal, what is the total number of moving voltage waves?
1. One
 2. Two
 3. Three
 4. Four
- 3-50. At the end of an open-ended transmission line, which, if any, of the following voltage waves is at its maximum value?
1. Incident
 2. Reflected
 3. Resultant
 4. None
- 3-51. On a transmission line that is carrying an ac signal, what is the relative value of the resultant voltage wave $1/4$ wavelength from the open end?
1. Maximum positive
 2. Maximum negative
 3. Zero
- 3-52. In an open-ended transmission line, the resultant ac current waveform is always zero at what point(s)?
1. At the open end only
 2. $1/2$ wavelength from the open-end only
 3. At the open end and $1/2$ wavelength from the open-end
- 3-53. The resultant waveform obtained by adding the incident wave to the reflected wave is referred to as a/an
1. standing wave
 2. negative wave
 3. algebraic wave
 4. concentrated wave
- 3-54. On an open-ended transmission line, what is the phase relationship between the standing waves of voltage and current?
1. In phase
 2. 45 degrees out of phase
 3. 90 degrees out of phase
 4. 180 degrees out of phase
- 3-55. Which of the following conditions exist at the end of a shorted transmission line?
1. Maximum voltage and minimum current
 2. Maximum voltage and maximum current
 3. Minimum voltage and maximum current
 4. Minimum voltage and minimum current
- 3-56. Transmission line is considered to be nonresonant (flat) when it is terminated in which of the following ways?
1. In an impedance equal to Z_0
 2. In an impedance that is infinite
 3. In an inductive reactance greater than Z_0
 4. In a capacitive reactance greater than Z_0

- 3-57. Of the following terms, which one is used for the nonresonant transmission line?
1. A tuned line
 2. A shorted line
 3. An untuned line
 4. A terminated line
- 3-58. A transmission line that is resonant is sometimes referred to as which of the following types of lines?
1. Tuned
 2. Matched
 3. Untuned
 4. Unmatched
- 3-59. A short-circuited section of transmission line that is an odd number of quarter-wavelengths long shows the same characteristics as which of the following devices?
1. A series-resonant circuit
 2. A parallel-resonant circuit
 3. An inductive reactance equal to Z_0
 4. A capacitive reactance equal to Z_0
- 3-60. Which of the following circuits appears as a very high resistance at resonance?
1. Nonresonant
 2. Series-resonant
 3. Parallel-resonant
 4. Each of the above
- 3-61. When a series-resonant circuit is resonant at a frequency above the generator frequency, it acts as what type of circuit?
1. Open
 2. Resistive
 3. Inductive
 4. Capacitive
- 3-62. Which of the following sections of transmission line can be used as a parallel-resonant circuit?
1. A shorted $1/4$ -wavelength section
 2. An open $1/4$ -wavelength section
 3. A shorted $1/2$ -wavelength section
 4. An open $3/4$ -wavelength section
- 3-63. A generator connected to an open-ended line greater than $1/4$ wave-length but less than $1/2$ wave-length senses which of the following circuit component characteristics?
1. Zero reactance
 2. Low resistance
 3. Inductive reactance
 4. Capacitive reactance
- 3-64. Which of the following conditions of current (I) and impedance (Z) exist at even quarter-wave points on a shorted transmission line?
1. Low I, low Z
 2. Low I, high Z
 3. High I, high Z
 4. High I, low Z
- 3-65. What is the maximum distance, in wavelengths (λ), between adjacent zero-current points on an open-circuited line?
1. 1λ
 2. $1/2 \lambda$
 3. $1/4 \lambda$
 4. $1/8 \lambda$
- 3-66. When a line is terminated in a capacitance, the capacitor performs which, if any, of the following circuit actions?
1. It absorbs all the energy
 2. It reflects all the energy
 3. It reacts as if it were a short
 4. None

- 3-67. When a transmission line is terminated in an inductive reactance, which, if any, of the following phase shifts takes place with respect to the current and voltage?
1. Only voltage is phase-shifted
 2. Only current is phase-shifted
 3. Both voltage and current are phase-shifted
 4. None
- 3-68. When a transmission line is terminated in a resistance greater than Z_0 , which of the following conditions exist?
1. The end of the line appears as an open circuit
 2. Standing waves appear on the line
 3. Voltage is maximum and current is minimum at the end of the line
 4. Each of the above
- 3-69. On a transmission line, reflections begin at which of the following locations?
1. At the load
 2. At the source
 3. At the middle
 4. At the half-wavelength point
- 3-70. The ratio of maximum voltage to minimum voltage on a transmission line is referred to as the
1. rswr
 2. pswr
 3. vswr
 4. iswr
- 3-71. Which of the following ratios samples the magnetic field along a line?
1. Vswr
 2. Pswr
 3. Iswr
 4. Rswr

ASSIGNMENT 4

Textbook assignment: Chapter 4, "Antennas," pages 4-1 through 4-60.

- 4-1. Radio energy is transmitted through which of the following mediums?
1. Rock
 2. Soil
 3. Water
 4. Space
- 4-2. Energy is transmitted from a transmitter into space using which of the following devices?
1. A receiver
 2. A delay line
 3. A receiving antenna
 4. A transmitting antenna
- 4-3. Transmitted rf energy takes what form as it is sent into space?
1. A magnetic field only
 2. An electric field only
 3. An electromagnetic field
 4. A static dielectric field
- 4-4. The dimensions of a transmitting antenna are determined by which of the following factors?
1. Transmitted power
 2. Transmitted frequency
 3. Distance to the receiver
 4. Antenna height above the ground
- 4-5. A device used to radiate or receive electromagnetic wave energy is referred to as a/an
1. feeder
 2. antenna
 3. transmitter
 4. coupling device
- 4-6. An antenna that can be mounted to radiate rf energy either vertically or horizontally is classified as which of the following types?
1. Hertz
 2. Marconi
 3. Quarter-wave
 4. Both 2 and 3 above
- 4-7. A complete antenna system consists of which of the following components?
1. A feeder, a coupling device, and a transmitter
 2. A feeder line, a coupling device, and an antenna
 3. An antenna, a transmission line, and a receiver
 4. An impedance-matching device, a feeder, and a transmission line
- 4-8. What component in an antenna system transfers energy from the transmitter to the antenna?
1. A feeder
 2. A delay line
 3. A choke joint
 4. A rotating joint
- 4-9. The type, size, and shape of an antenna are determined by which of the following factors?
1. Power output of the transmitter
 2. Transmitter frequency
 3. Direction to the receiver
 4. Each of the above

- 4-10. Moving electric and magnetic fields in space have what (a) phase and (b) angular relationships?
1. (a) In phase
(b) Perpendicular
 2. (a) In phase
(b) Displaced 45°
 3. (a) Out of phase
(b) Displaced 45°
 4. (a) Out of phase
(b) Perpendicular
- 4-11. What is the length of each half of the wire for a dipole antenna?
1. Wavelength
 2. 3/4 wavelength
 3. 1/2 wavelength
 4. 1/4 wavelength
- 4-12. On a dipole antenna, the sinusoidal variation in charge magnitude lags the sinusoidal variation in current by what amount?
1. 1 cycle
 2. 1/2 cycle
 3. 1/4 cycle
 4. 1/8 cycle
- 4-13. On a standing wave, the points of high current and voltage are identified by which of the following terms?
1. Peaks
 2. Nodes
 3. Poles
 4. Loops
- 4-14. The presence of standing waves indicates which of the following conditions of an antenna?
1. Resonance
 2. Saturation
 3. Nonresonance
 4. Minimum efficiency
- 4-15. The antenna property that allows the same antenna to both transmit and receive energy is
1. gain
 2. resonance
 3. reciprocity
 4. directivity
- 4-16. There is a ratio between the amount of energy propagated in certain directions by a directional antenna compared to the energy that would be propagated in these directions if the antenna were not directional. This ratio is known as which of the following antenna characteristics?
1. Gain
 2. Directivity
 3. Reciprocity
 4. Polarization
- 4-17. The polarization plane of the radiation field is determined by which of the following fields?
1. Electric field only
 2. Magnetic field only
 3. Electromagnetic field
- 4-18. For best reception of a signal from a horizontally polarized antenna, the receiving antenna should be mounted so that it has what relationship with the transmitting antenna?
1. 0 degrees
 2. 45 degrees
 3. 90 degrees
 4. 135 degrees
- 4-19. An electric field that rotates as it travels through space exhibits what type of polarization?
1. Vertical
 2. Spherical
 3. Elliptical
 4. Horizontal

- 4-20. For ground-wave transmissions, what type of polarization is required?
1. Vertical
 2. Spherical
 3. Elliptical
 4. Horizontal
- 4-21. For high-frequency operation, which of the following antenna polarization patterns is preferred?
1. Vertically polarized
 2. Spherically polarized
 3. Elliptically polarized
 4. Horizontally polarized
- 4-22. Omnidirectional transmission is obtained from which of the following antennas?
1. Elliptically polarized
 2. Horizontal half-wave
 3. Vertical half-wave
 4. Each of the above
- 4-23. With an antenna height of 40 feet and a transmitter frequency of 90 megahertz, which of the following antenna radiation patterns is best for transmitting over bodies of water?
1. Vertically polarized
 2. Spherically polarized
 3. Elliptically polarized
 4. Horizontally polarized
- 4-24. To select a desired signal and discriminate against interfering signals from strong vhf and uhf broadcast transmissions, which of the following actions should you take?
1. Increase receiver gain
 2. Make the transmitting antenna bi-directional
 3. Use a vertically polarized receiving antenna
 4. Use narrowly directional arrays as receiving antennas
- 4-25. A vertically mounted transmission line is LEAST affected by which of the following antenna radiation patterns?
1. Vertically polarized
 2. Spherically polarized
 3. Horizontally polarized
 4. Elliptically polarized
- 4-26. An antenna with which of the following radiation resistance values will exhibit reduced efficiency?
1. 39 ohms
 2. 82 ohms
 3. 107 ohms
 4. 150 ohms
- 4-27. An isotropic radiator radiates energy in which of the following patterns?
1. Vertical
 2. Bi-directional
 3. Unidirectional
 4. Omnidirectional
- 4-28. An ordinary flashlight is an example of what type of radiator?
1. Isotropic
 2. Polarized
 3. Anisotropic
 4. Stroboscopic
- THIS SPACE LEFT BLANK INTENTIONALLY.

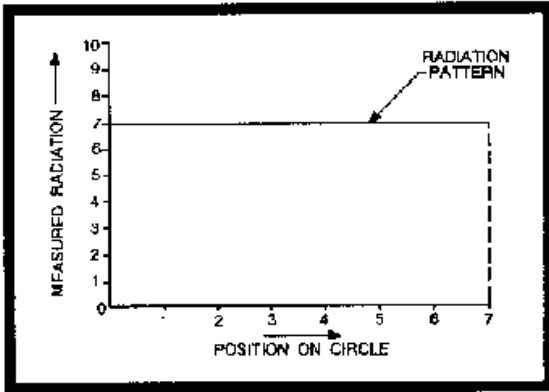

Figure 4-A.—Rectangular-coordinate graph.

IN ANSWERING QUESTION 4-29, REFER TO FIGURE 4-A.

4-29. How many points on the graph can represent the value of 7 radiation units at position 2 of the circle?

1. One
2. Two
3. Three
4. Four

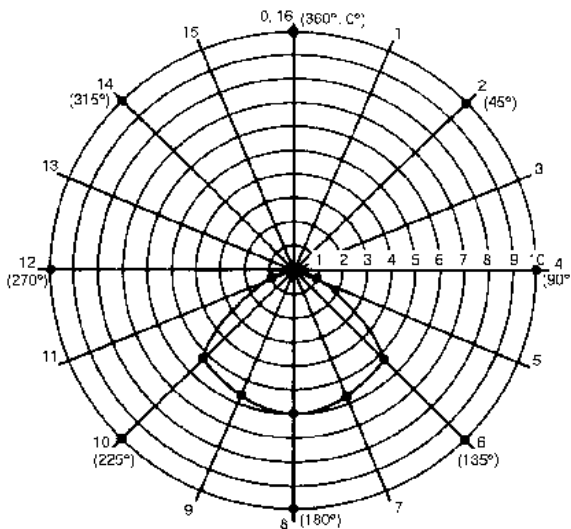

Figure 4-B.—Polar-coordinate graph.

IN ANSWERING QUESTIONS 4-30 AND 4-31, REFER TO FIGURE 4-B.

4-30. Compared with the rectangular-coordinate graph, the polar-coordinate graph has the advantage of showing which of the following antenna characteristics?

1. Polarization
2. Radiation pattern
3. Phase relationship
4. Gain versus directivity

4-31. The area enclosed by the radiation pattern is the

1. lobe
2. null
3. axis
4. coordinate

4-32. Inserting an inductor or capacitor in series with an antenna is one method of electrically changing the electrical length of an antenna. What is this method called?

1. Loading
2. Inserting
3. Unloading
4. Decoupling

4-33. Many complex antennas are constructed from what basic antenna?

1. The Marconi antenna
2. The full-wave antenna
3. The half-wave antenna
4. The quarter-wave antenna

4-34. On an energized half-wave antenna, which of the following electrical conditions exist?

1. Voltage is maximum at the ends
2. Voltage is minimum at the ends
3. Current is maximum at the ends
4. Impedance is minimum at the center

- 4-35. Which of the following radiation patterns is/are exhibited by a simple vertical doublet antenna?
1. Nondirectional in the horizontal plane
 2. Directional in the vertical plane
 3. Both 1 and 2 above
 4. Spherical in all planes
- 4-36. A method of feeding energy to a half-wave antenna is to connect one end through a capacitor to the output stage. What is this method of feeding called?
1. End feed
 2. Voltage feed
 3. Both 1 and 2 above
 4. Current feed
- 4-37. An antenna supplied by the center-fed method is fed at what point?
1. Low voltage and low current
 2. Low voltage and high current
 3. High voltage and low current
 4. High voltage and high current
- 4-38. The basic Marconi antenna has which of the following characteristics?
1. One-quarter wavelength and ungrounded
 2. One-half wavelength and grounded at one end
 3. One-half wavelength and insulated from ground
 4. One-quarter wavelength and grounded at one end
- 4-39. The Marconi antenna behaves as a dipole for which of the following reasons?
1. It is fed at one end
 2. An image antenna is formed by reflections from the ground
 3. A quarter-wavelength of conductor is buried in the ground and forms the rest of the dipole
 4. The applied signal is rectified so that only half the signal will appear on the quarter-wave antenna
- 4-40. A series of conductors arranged in a radial pattern and buried in the ground beneath the antenna is referred to as a
1. ground spur
 2. counterpoise
 3. ground screen
 4. ground reflector
- 4-41. A folded dipole can be used instead of a simple, center-fed dipole for which of the following purposes?
1. Matching voltage
 2. Matching impedance
 3. Increasing directivity
 4. Decreasing directivity
- 4-42. An antenna arrangement that has elements aligned in a straight line is referred to as what type array?
1. Isotropic
 2. Collinear
 3. Line-of-sight
 4. Unidirectional
- 4-43. To have current in two adjoining collinear half-wave elements in proper phase, they must be connected by which of the following stubs?
1. A shorted half-wave stub
 2. An open quarter-wave stub
 3. A shorted eighth-wave stub
 4. A shorted quarter-wave stub
- 4-44. To select a desired signal and discriminate against interfering signals, the receiving antenna should have which of the following characteristics?
1. Be omnidirectional
 2. Be highly directional
 3. Be vertically polarized
 4. Be horizontally polarized

- 4-45. Adding more elements to a collinear antenna array produces which of the following effects?
1. Increased gain
 2. Decreased gain
 3. Decreased directivity
 4. Mismatched impedances
- 4-46. What is the maximum number of elements ordinarily used in a collinear array?
1. One
 2. Two
 3. Three
 4. Four
- 4-47. Constructing a collinear array with elements longer than $1/2$ wavelength has which of the following effects on antenna characteristics?
1. Increased gain
 2. Decreased gain
 3. Increased frequency range
 4. Decreased frequency range
- 4-48. In a two-element collinear array, maximum gain is obtained when the center-to-center spacing between the ends of the elements is approximately what electrical distance?
1. Wavelength
 2. 0.15 wavelength
 3. 0.5 wavelength
 4. 0.75 wavelength
- 4-49. Compared with collinear arrays, broadside arrays have which of the following advantages?
1. Sharper tuning
 2. Broader bandwidth
 3. Broader frequency response
 4. Less coupling between dipole
- 4-50. Optimum gain is obtained from a broadside array when the spacing of its elements is which of the following distances?
1. One-half wavelength
 2. One-quarter wavelength
 3. Greater than one-half wavelength
 4. Slightly less than one-quarter
- 4-51. An end-fire array physically resembles the collinear array except that it is more compact. What disadvantage does the endfire array possess?
1. It has lower gain
 2. It has low radiation resistance
 3. It has loose coupling
 4. Each of the above
- 4-52. What is the range of electrical spacing between the elements of an end-fire array?
1. $3/4$ to 1 wavelength
 2. $1/2$ to $3/4$ wavelength
 3. $1/4$ to $1/2$ wavelength
 4. $1/8$ to $1/4$ wavelength
- 4-53. The end-fire array produces what type of lobes, if any, along the axis of the array?
1. Minor lobes
 2. Major lobes
 3. None
- 4-54. Assuming that the elements are correctly spaced, the directivity of an end-fire array may be increased by which of the following actions?
1. Increasing the frequency
 2. Decreasing the frequency
 3. Decreasing the number of elements
 4. Increasing the number of elements

- 4-55. A unidirectional pattern can be obtained from an end-fire array by using what phase relationship between the energy fed to adjacent elements?
1. 0°
 2. 45°
 3. 90°
 4. 180°
- 4-56. Energy is fed to a parasitic element using what method?
1. Direct coupling
 2. Inductive coupling
 3. Capacitive coupling
 4. Transmission-line coupling
- 4-57. The directivity pattern resulting from the action of parasitic elements depends on which of the following element characteristics?
1. Length of the element
 2. Diameter of the element
 3. Spacing between parasitic and driven elements
 4. Each of the above
- 4-58. The advantages of unidirectivity and increased gain can best be obtained by using which of the following elements in a parasitic array?
1. Driven elements only
 2. Reflector and director elements only
 3. Reflector, director, and driven elements
 4. Driven and director elements only
- 4-59. The ratio of energy radiated by an array in the principal direction of radiation to the energy radiated in the opposite direction describes which of the following relationships?
1. Side-to-side ratio
 2. Front-to-back ratio
 3. Driven-to-parasitic ratio
 4. Reflector-to-director ratio
- 4-60. The Yagi antenna is an example of what type of antenna array?
1. Driven
 2. End-fire
 3. Multielement parasitic
 4. Single-element parasitic
- 4-61. The addition of parasitic elements to the Yagi antenna has which of the following effects on antenna characteristics?
1. Increased gain
 2. Narrower beam width
 3. Narrower frequency response
 4. Each of the above
- 4-62. An antenna which is designed especially for vertically-polarized ground waves at low frequencies is the
1. Yagi antenna
 2. Marconi antenna
 3. Beverage antenna
 4. V antenna
- 4-63. What is the phase relationship of the signals that feed the V antenna?
1. 0°
 2. 45°
 3. 90°
 4. 180°
- 4-64. A rhombic antenna is essentially a combination of which of the following antennas?
1. Two stacked long-wire radiators
 2. Two V antennas placed side by side
 3. Two collinear arrays in parallel
 4. Four parallel half-wave radiators
- 4-65. A rhombic antenna has which of the following advantages?
1. Simple construction
 2. Wide frequency range
 3. Noncritical adjustment
 4. Each of the above

- 4-66. The principal disadvantage of the rhombic antenna is its
1. poor directivity
 2. large antenna size
 3. low antenna voltage
 4. high-frequency inefficiency
- 4-67. The unidirectional radiation pattern of the rhombic antenna is caused by which of the following antenna characteristics?
1. Size
 2. Shape
 3. Termination resistance
 4. Frequency of the input energy
- 4-68. Horizontal half-wave antennas mounted at right angles to each other in the same horizontal plane make up which of the following antennas?
1. Rhombic
 2. Flat-top
 3. Turnstile
 4. Ground-plane
- 4-69. The most common means of obtaining a low-radiation angle from a vertical quarter-wave antenna is by what procedure?
1. Decreasing power
 2. Increasing frequency
 3. Adding a ground plane
 4. Rotating the antenna to a horizontal plane
- 4-70. A corner reflector antenna is used for which of the following purposes?
1. To decrease frequency range
 2. To increase frequency range
 3. To produce a unidirectional pattern
 4. To produce an omnidirectional pattern
- 4-71. If a corner-reflector antenna is horizontally polarized, its radiation pattern will take on what shape?
1. A narrow beam in the horizontal plane
 2. A narrow beam in the vertical plane
 3. A beam similar to a half-wave dipole in the horizontal plane
 4. A beam similar to a half-wave dipole with a reflector in the vertical plane
- 4-72. When radio or radar antennas are energized by transmitters, you must not go aloft until which of the following requirements are met?
1. A safety harness has been issued to you
 2. All transmitters are secured and tagged
 3. A working aloft "chit" has been filled out and signed by proper authority
 4. Each of the above

LAST MODIFIED:

Wednesday, 21-Jul-2004 19:14:29 PDT

ANTENNA BASICS

YOU ARE HERE: [HOME](#) > [ANTENNAS](#) > ANTENNA BASICS

What are the basics of antennas?

Antennas, to quote a friend, are one of life's eternal mysteries. "All I'm totally certain of is that any antenna is better than no antenna and the antenna should preferably be erected as high and be as long as is possible or desirable". Here we will discuss the very basics of antennas. Remember that thought: **these are just some introductory antenna basics**. Each type of antenna will eventually have its own page. In particular I would commend everyone to read my page on [earth dangers](#). I think it ought to be compulsory reading.

The basic antenna

The most basic antenna is called "a quarter wave vertical", it is a quarter [wavelength](#) long and is a vertical radiator. Typical examples of this type would be seen installed on motor vehicles for two way communications. Technically the most basic antenna is an "isotropic radiator". This is a mythical antenna which radiates in all directions as does the light from a lamp bulb. It is the standard against which we sometimes compare other antennas.

This type of antenna relies upon an "artificial ground" of either drooping radials or a car body to act as ground. Sometimes the

antenna is worked against an actual ground - see later.

Antenna Polarisation

Depending upon how the antenna is orientated physically determines it's polarisation. An antenna erected vertically is said to be "vertically polarised" while an antenna erected horizontally is said (not so surprising) to be "horizontally polarised". Other specialised antennas exist with "cross polarisation", having both vertical and horizontal components and we can have "circular polarisation".

Note that when a signal is transmitted at one polarisation but received at a different polarisation there exists a great many [decibels](#) of loss.

This is quite significant and is often taken advantage of when TV channels and other services are allocated. If there is a chance of co-channel interference then the license will stipulate a different polarisation. Have you ever noticed vertical and horizontal TV antennas in some areas. Now you know why.

Antenna Impedance

Technically, antenna [impedance](#) is the ratio at any given point in the antenna of voltage to current at that point. Depending upon height above ground, the influence of surrounding objects and other factors, our quarter wave antenna with a near perfect ground exhibits a nominal input impedance of around 36 ohms. A half wave dipole antenna is nominally 75 ohms while a half wave folded dipole antenna is nominally 300 ohms. The two previous examples indicate why we have 75 ohm coaxial cable and 300 ohm ribbon line for TV antennas.

A quarter wave antenna with drooping quarter wave radials exhibits a nominal 50 ohms impedance, one reason for the existence of 50 ohm coaxial cable.

The quarter wave vertical antenna

The quarter wave vertical antenna is usually the simplest to construct and erect although I know a great many people who would dispute that statement. In this context I am speaking of people (the majority) who have limited space to erect an antenna.

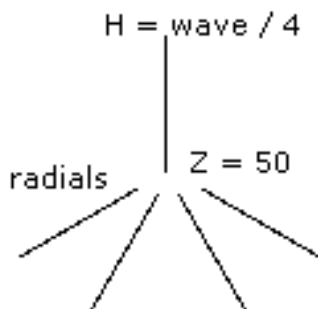

Figure 1. - a quarter wave vertical antenna with drooping radials

In figure 1 we have depicted a quarter wave vertical antenna with drooping radials which would be about 45 degrees from horizontal. These 45 degree drooping radials simulate an artificial ground and lead to an antenna impedance of about 50 ohms.

A quarter wave vertical antenna could also be erected directly on the ground and indeed many AM radio transmitting towers accomplish this especially where there is suitable marshy ground noted for good conductivity. An AM radio transmitting tower of a quarter wave length erected for say 810 KHz in the AM band would have a length of nearly 88 metres (288') in height.

The formula for quarter wave is $L = 71.25 \text{ metres} / \text{freq (mhz)}$ and in feet $L = 234 / \text{freq (mhz)}$. Note the variance from the standard wavelength formula of $300 / \text{freq}$. This is because we allow for "velocity factor" of 5% and our wavelength formula becomes $285 / \text{freq}$.

When a quarter wave antenna is erected and "worked" against a good rf ground (called a Marconi Antenna) the earth provides a "mirror" image of the missing half of the desired half wave antenna.

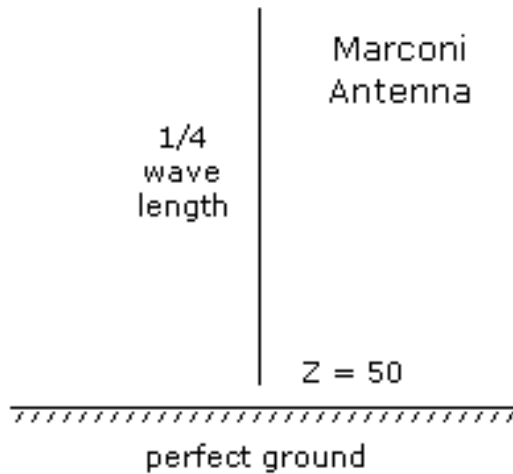

Figure 2. - a marconi antenna

In figure 2 above where I have depicted the Marconi Antenna imagine a duplicate of the quarter wave antenna being in existence from the top of the ground and extending down the page. This is the mirror image.

Half wave dipole antenna

The half wave dipole antenna becomes quite common where space permits. It can be erected vertically but is more often than not erected horizontally for practical reasons. I gave quite a good example of its use in my paper on [radio telescopes](#) from my original site. I have reproduced it in figure 3 below.

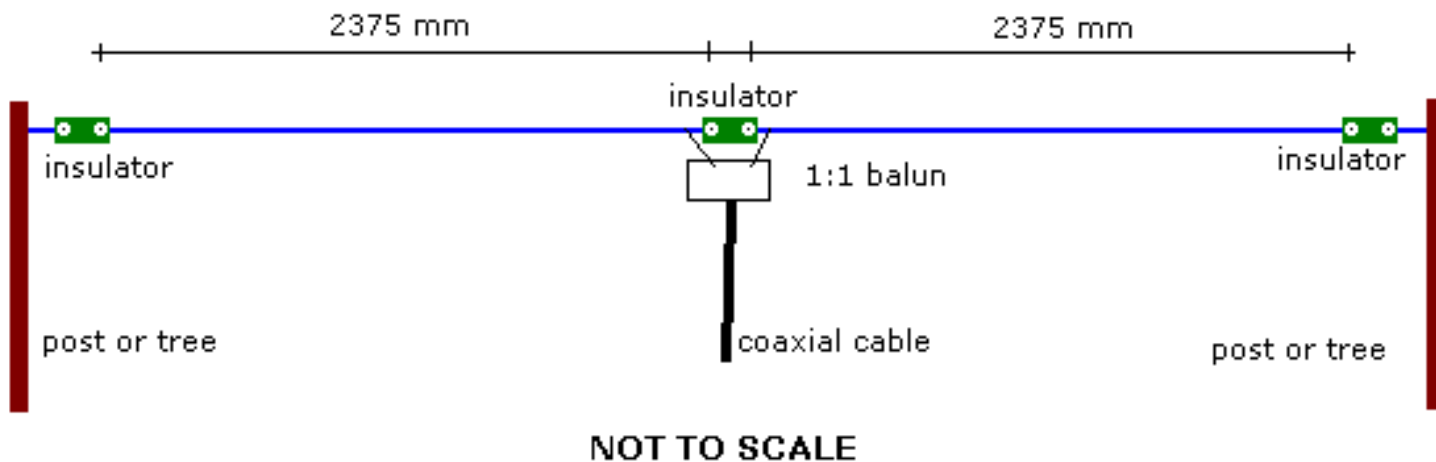

Figure 3. - half wave dipole antenna

This particular antenna was dimensioned for use at 30 Mhz. You will note that the left and right hand halves are merely quarter wave sections determined by the formula given earlier. The input impedance (affected by many factors) is nominally 50 ohms.

As with all antennas, the height above ground and proximity to other objects such as buildings, trees, guttering etc. play an important part. However, reality says we must live with what we can achieve in the real world notwithstanding what theory may say.

People erect half wave dipoles in attics constructed of fine gauge wire - far from ideal BUT they get reasonable results by living with less than the "ideal". A lesson in life we should always remember in more ways than one.

The folded dipole antenna

The folded dipole antenna is probably only ever seen as a TV antenna. It exhibits an impedance of 300 ohms whereas a half wave dipole is 75 ohms and I'm certain someone will be alert enough to ask "why 75 ohms, if figure 3 above is 50 ohms?".

Within the limits of my artistic skills I have depicted a folded dipole antenna below.

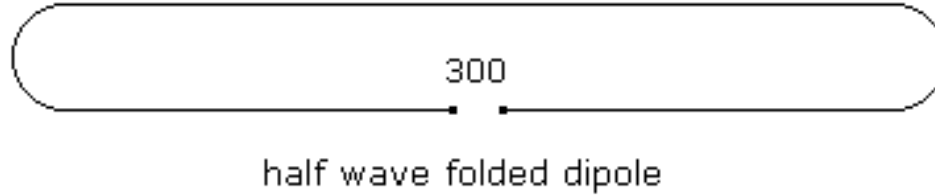

Figure 4. - half wave folded dipole

One powerful advantage of a folded dipole antenna is that it has a wide bandwidth, in fact a one octave bandwidth. This is the reason it was often used as a TV antenna for multi channel use. Folded dipole antennas were mainly used in conjunction with Yagi antennas.

The Yagi antenna

The Yagi antenna or more correctly, the Yagi - Uda antenna was developed by Japanese scientists in the 1930's. It consists of a half wave dipole (sometimes a folded one, sometimes not), a rear "reflector" and may or may not have one or more forward "directors". These are collectively referred to as the "elements".

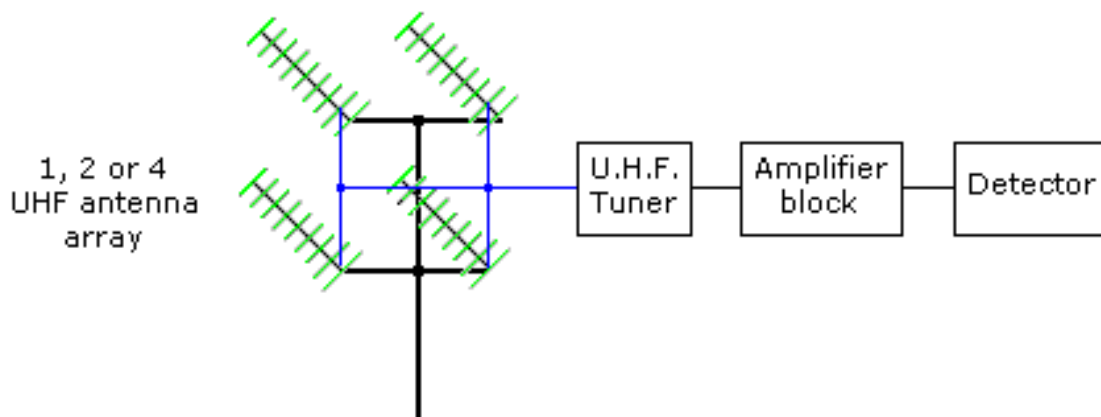

Figure 5. - the Yagi antenna

In figure 5 above I have reprinted a UHF Yagi antenna array from my [radio telescopes](#) page. You will note, not altogether clearly.

However in figure 6 below, which happens to be a photograph of a neighbour's TV antenna, I can clearly point out details of a practical Yagi antenna.

This particular antenna has been optimised for dual band operation. It is designed to pick up both VHF and UHF transmissions. Because I live in a regional of NSW in Australia, TV antennas tend to be single channel types designed either for higher gain or better directivity. Different examples will be presented later.

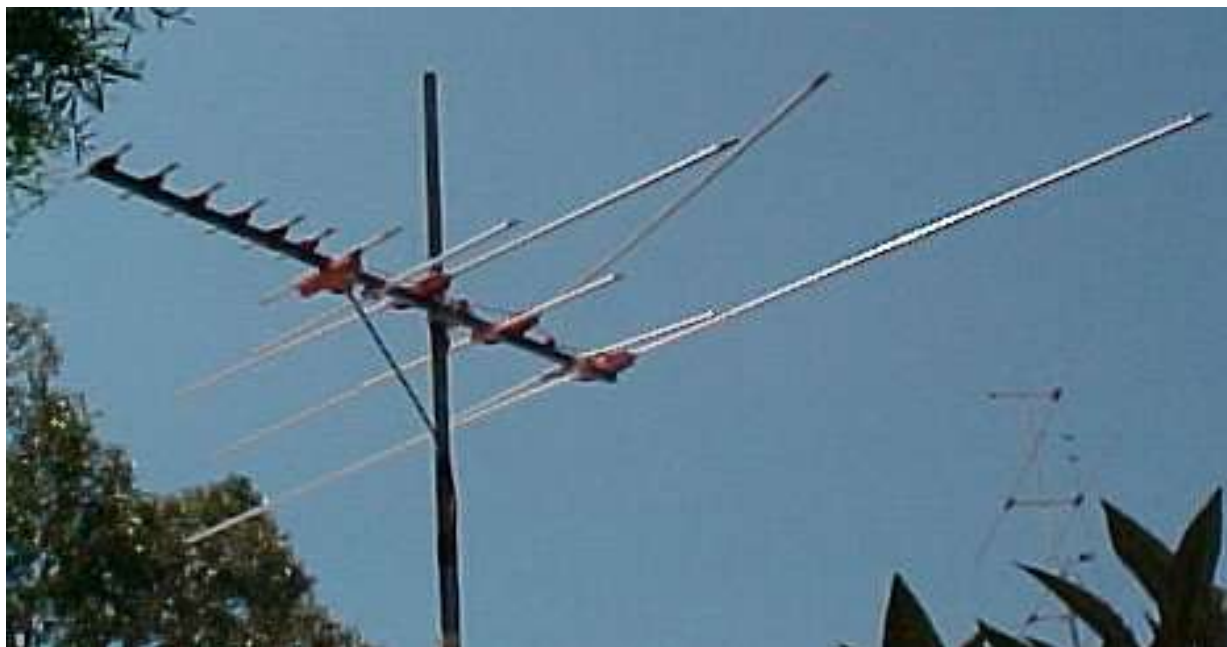

Figure 6. - a practical Yagi TV antenna

Looking from left to right on this dual band Yagi we have six UHF "director" elements which improve gain and directivity. Next is the UHF half wave dipole which could have easily been a folded dipole but is in fact a plain half wave dipole.

The next three much longer elements form a "phased array" for the

VHF band. I am unsure of the function of the three remaining smaller elements, information is quite scant here but one would certainly be a UHF "reflector". Likely the other two also fulfill this function also.

Note: This is a horizontally polarised antenna and is orientated roughly NNW, 315 degrees.

You will notice the effect of very strong storms from the sea have had in bending the second larger elements. In my locality storms are a problem but not as much as roosting parrots such as large sulphur crested cockatoos.

UHF Yagi antenna

In the photograph in figure 7 below you can see a classic UHF Yagi antenna. It has a total of nineteen "elements" comprising seventeen "directors", a fancy folded dipole with a "low-noise mast head amplifier" and a "reflector".



Figure 7. - a vertically polarised UHF Yagi antenna

This is a vertically polarised UHF Yagi antenna and it is orientated WSW or 225 degrees. It does in fact pick up signals about 100 Km or 60 mile distant from Sydney.

This is the very same antenna I was suggesting to be used in the radio telescope array I depicted in figure 5 above.

Stacked half wave dipoles or a collinear array

The majority of TV antennas in my retirement village are stacked half wave dipoles. These consist of four sets of a half wave dipole and a reflector only, but mounted one above another. These antennas owe their origin to the days we only had VHF TV in the area. Surprising with the introduction of UHF they continued to function quite well in picking up UHF as well. This particular antenna is my one and I've never had the need to go to a UHF antenna. The top two elements normally are home to roosting "top knot" pigeons, a pigeon native to Australia.



Figure 8. - four stacked half wave dipoles collinear antenna

To the left of the photograph are the "reflectors" and to the right are the four vertically stacked half wave dipoles. The wires connecting each half wave dipole are done in a "phased way". This comprises a collinear antenna array and is so arranged for improved gain.

Note this antenna is horizontally polarised.

Loop Antennas

The loop antenna comes in an amazing number of configurations. It is a "small space" antenna and although extremely inefficient is capable of surprising results. In receiving applications the loop antenna works on the principle of the "**differences**" in voltages induced by the current flowing in the sides of the antenna. As you might imagine these difference voltages can be extremely minute in amplitude and any loop antenna usually requires an associated amplifier capable of at least 25 dB power gain following it.

One example of a shielded loop antenna is taken from my tutorial on [mobius winding techniques](#) is shown in figure 9 below.

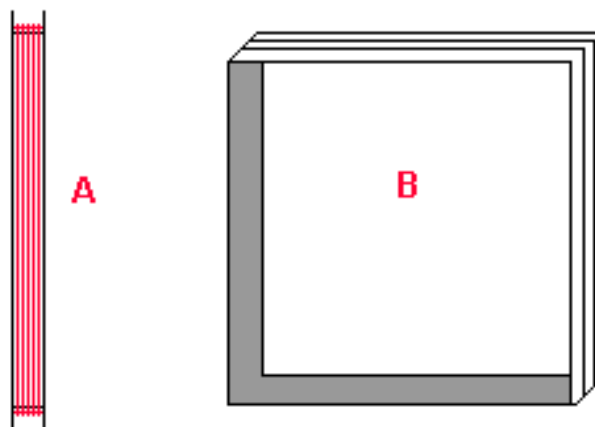

Figure 9. - mobius winding of a loop antenna

This is the general loop antenna which has one interesting characteristic. It responds well to signals arriving in one direction, either from the left hand side of your computer screen or the right hand side of your computer screen for the loop shown in figure 9 (b) above. Signals from either your face or from behind your monitor would produce equal signal currents from both sides of the loop and consequently produce no difference voltage output.

Technically speaking, a loop antenna responds to the magnetic field

rather than the electric field.

Rather than being omnidirectional (as a whip antenna would be) the loop antenna responds to the cosine of the angle between its face and the direction of arrival of the electromagnetic wave. This actually produces a figure eight pattern, which for receiving presents no problems. The addition of a small whip antenna in conjunction with proper phasing allows the direction ambiguity to be resolved and we have an antenna relatively ideal for direction finding.

The most common loop antenna you will encounter is the loopstick antenna [in the U.K. it is referred to as a "ferrite rod antenna"] built into portable receivers. In figure 10 below is the AM and shortwave loopstick antenna in a Sanyo model RP2127 MW / SW receiver (it's old).



Figure 10. - AM and shortwave loopstick antenna

The AM and shortwave loopstick antenna is located in the upper half under the words "loopstick antenna". For greater efficiency and size reduction, a loopstick antenna is wound on a "ferrite" rod. This

particular one happens to be circular but you may encounter ones which are rectangular.

As an experiment you might, if you have a loopstick antenna radio available, tune to a weak station and rotate the radio around 360 degrees. You should notice two points 180 degrees apart where the signals seem to be the strongest and similarly notice two other points 180 degrees apart where the signals seem to be the weakest - these are called "nulls". This is the aid to "Radio Direction Finding - RDF"

Terminated Tilted Folded Dipole

Now here is a little gem. The terminated tilted folded dipole is bound to give a "rush of blood to the head" of any avid DX'er (that means long distance -dx- receive / transmit enthusiast).

The terminated tilted folded dipole is somewhat similar to the half wave folded dipole in figure 4 above yet the claims for its performance are quite astonishing. The terminated tilted folded dipole is claimed to have a bandwidth of something like 5 or 6 to one, been extensively tested and adopted by the US Navy, easy to construct from readily available materials and, has a feedpoint impedance of around 300 ohms.

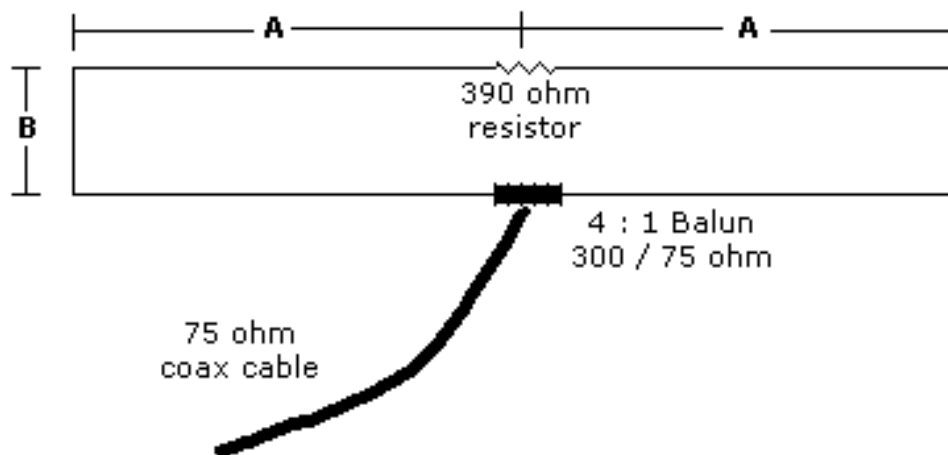

Figure 11. - Terminated Tilted Folded Dipole

The dimensions "A" and "B" for a terminated tilted folded dipole are as follows:

Each leg "A" = [2 X pi (15.25 / Fo)] and;

Distance "B" = [2 X pi (0.915 / Fo)]

where in both instances $2 \times \pi = 6.28$ and Fo is in Mhz.

There seems to be some debate about the exact formula, my friend L. B. Cebik (see next) says:

"The "Wide-Long" version coincides with standard construction formulations, since the antenna is about $300/F(\text{MHz})$ long and $10/F(\text{MHz})$ wide. (Excessively fussy cutting formulas for this antenna are largely superfluous, since strict resonance is not in question)."

My friend L. B. Cebik (see later) has modeled this antenna. [Modeling the T2FD](#)

Further comprehensive details on the claims for the amazing terminated tilted folded dipole antenna and its construction can be found at:

<http://www.hard-core-dx.com/nordicdx/antenna/wire/t2fd.html>

Conclusion on antenna basics

The reason there has been emphasis on TV antennas is simply because nearly everyone can look at examples in their own locality for comparison. At TV frequencies the physical dimensions are such I can offer practical examples with photographs.

The same basic principles apply at HF and LF although physical sizes tend to be totally impractical.

As time permits I will flesh out more and more in depth articles on all these antennas and even more types not even mentioned here. This page alone comprises well over 2,000 words so you can imagine the job ahead with competing demands on my time. Meanwhile consider this important publication on antennas.

Meanwhile I would also suggest that you take a good look at [L.B. Cebik 's W4RNL](#) great web site. My good friend LB is "THE antenna guru".

PRACTICAL ANTENNA HANDBOOK

By Joseph Carr, from TAB Books

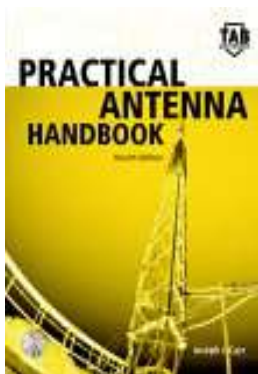

Designed for use by the novice as well as the professional, this book/CD- ROM combo gives the reader all kinds of projects with material that explains why they work.

A wide variety of antennae are covered: high frequency dipole, vertically polarized HF, multiband and tunable wire, hidden and limited space, directional phased vertical and directional beam, VHF/UHF transmitting and receiving, shortwave reception, microwave, mobile, marine and emergency.

This third edition has new material on wire antenna construction methods, antenna modeling software, antennas for radio astronomy and Radio Direction Finding, and antenna noise temperature.

BUY NEW FROM AMAZON

 **ORDER - U.S.A. - [Practical Antenna Handbook](#)**

A WORTHWHILE PUBLICATION ON THE TOPIC OF ANTENNA BALUNS

 **ORDER - U.S.A. NOW [Building and Using Baluns and Ununs](#) : Practical Designs for the Experimenter - by Dr. Jerry Sevick, W2FMI.**

Got a question on this topic?

If you are involved in electronics then consider joining our ["electronics Questions and Answers"](#) news group to ask your question there as well as sharing your thorny questions and answers. Help out your colleagues!.

The absolute fastest way to get your question answered and yes, I DO read most posts.

This is a mutual help group with a very professional air about it. I've learn't things. Not for absolute newcomers to ask questions BUT it is an excellent learning resource for lurkers.

RELATED TOPICS ON ANTENNA BASICS

[baluns](#)

[earth dangers](#)

[wavelength](#)

[decibels](#)

[impedance](#)

[mobius winding techniques](#)

[radio telescopes](#)

YOU ARE HERE: [HOME](#) > [ANTENNAS](#) > ANTENNA BASICS

the author Ian C. Purdie, VK2TIP of www.electronics-tutorials.com asserts the moral right to be identified as the author of this web site and all contents herein. Copyright © 2000, all rights reserved. See [copying and links](#). These electronic tutorials are provided for individual private use and the author assumes no liability whatsoever for the application, use, misuse, of any of these projects or electronics tutorials that may result in the direct or indirect damage or loss that comes from these projects or tutorials. All materials are provided for free private and public use.

Commercial use prohibited without prior written permission from www.electronics-tutorials.com.

Copyright © 2000 - 2001 - 2002, all rights reserved. URL - <http://www.electronics-tutorials.com/antennas/antenna-basics.htm>

Updated 25th March, 2002

webmaster@electronics-tutorials.com

11 Meter Antennas

[Home](#)

[Web Links](#)

[Search](#)

[Antenna Basics](#)

[Coax Basics](#)

Antenna Types

I. Omnidirectional

- [Verticals](#)

II. Directional

- [Yagi](#)
- [Cubical Quad](#)
- [Hybrid](#)

[Mobile Antennas](#)

Performance Tips

- [Co-Phasing](#)
- [Circular Polarization](#)
- [Angle of Radiation](#)
- [Earth Ground](#)

Antenna Building

- [4 Element Quad](#)
- [4 Element Yagi NEW!](#)

Get the true facts about different type of Citizen Band / 11 Meter antennas!

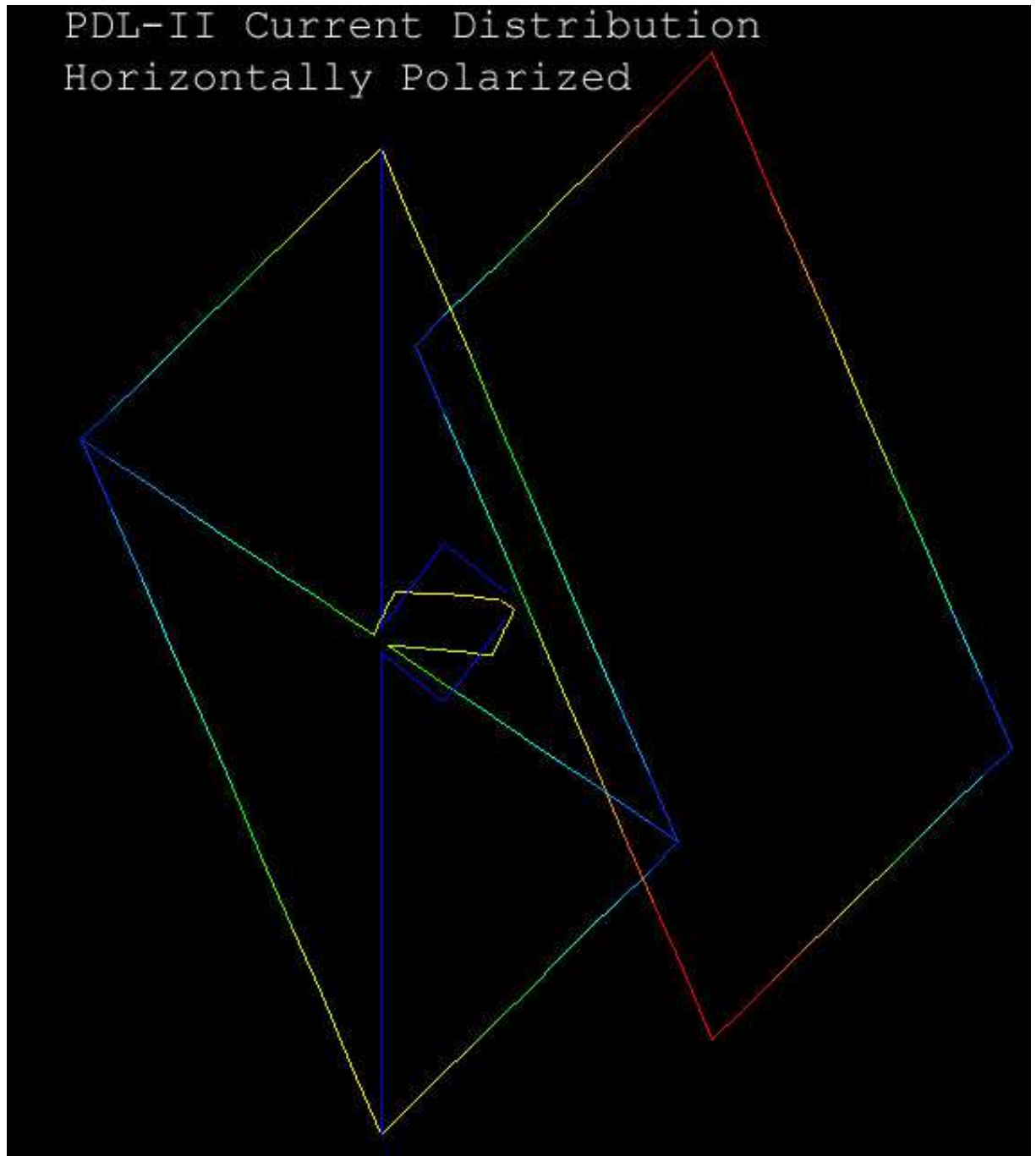

I have been studying dual polarity quad such as the Avanti PDL-II pictured above. Stay tuned for my latest article on building the ultimate dual polarity cubical quad!

Last update: Wednesday, 19-Nov-2003 23:40:43 EST Updated!



Hello, this site is dedicated to bringing true information about the different types of antennas you can use, buy and build for Citizen Band Radio and 11 Meter DXing. From concept to construction, I have set out to provide the most technically correct information possible. It contains information from antenna basics to advanced antenna theories such as the angle of radiation. I believe that it is not necessary to have great knowledge of electric fundamentals to understand how an antenna works. I have included tons of figures so that you can see what I am talking about! This site should be of interest to all CB users and 11 meter DXers because the station antenna provides the most improvement in station performance (even more so than an amplifier) when it is built correctly.

I decided to do this after all the info I read at antenna manufactures web sites. They all try to sell you their antenna. On one site I read says top loaded mobile antennas are the best, even better than base loaded. Then you read the web site of a company that makes base load mobiles only to find out base loaded are the best. Good thing is, I am not trying to sell you an antenna. Most of these web pages (and ad's in magazines) are done by the advertising department, not by the antenna engineers. And those advertised gain numbers are not regulated by any government agency! If you are looking for quick answers, frequently asked questions, this is not the place to start reading. I recommend reading it all, so that you get all the important concepts. Another reason I decided to this page is lack of good information on the web about antennas in general. Everyone has a "resource" site with a 1000 dead links to antennas manufacture pages....but no one has any *real* content. So here is my attempt at it! If there are any section that you would like to see added, let me know. For further reading see my [BIBLIOGRAPHY](#)

This page *has* to be viewed at a resolution *greater* than 800x600. I am sorry if you can not turn up the resolution any higher than 800x600, but I had to make the figures big enough to show detail clearly. You know your resolution is too small if you have to scroll out to read the end of each line in the sections (not this page, however). Click [HERE](#) for instructions on how to turn the resolution up in Windows 95/98/NT.

The Yagi building page is up!

- Scott, 2 Sugar Delta 789

Antenna Basics

Where to start reading if you are not really familiar with antenna basics such as radiation resistance, SWR, antenna bandwidth and polarization. Even if you have heard of these terms, read on to get a better understanding of all the essential fundamental antenna subjects. Discussion on the different type of antennas will use terminology explained here.

Coax Basics

Information about coaxial cable. Wonder why changing the your coax length changes the SWR of your antenna? Subjects such as impedance and velocity factor will be explained.

Antenna Types

Details the most common types of antennas used on 11 meters. Different types of omnidirectional and beams are covered and explains which design most common commercial CB antennas use. This is the section to read if you do not want to build your own antenna but figure out which commercial design best suites you. Make sure you read the "Hybrid" section if you own a Moonraker (or any beam with a quad reflector) for an important note.

Mobile Antennas

Explains mobile antenna basics.

Performance Tips

Four ways to improve your stations performance greatly.

- Co-Phase your antennas for 3db more gain
- Circular Polarize your dual polarity beam for solid DX contacts
- Angle of Radiation, Match the height of your antenna to the distance you are trying to communicate
- Really Ground that radio for improved receiver performance!

Antenna Building

Build your own optimized DX antenna. Not for the faint of heart. Now includes a JavaScript Calculator to fully automate designing the antenna for the frequency you talk on (Cubical Quad)!

- 4 Element Cubical Quad
- 4 Element Yagi NEW!

[Scott <scott2RP789@netscape.net>](mailto:scott2RP789@netscape.net)

All Content Copyright 1998,1999,2000

.

This section has moved. [Click here](#) if your browser doesn't support Refresh tags.

[Click Here to
Order this information in Print](#)

[Click Here to
Order this information on CD-
ROM](#)

[Click Here to
Download this information in PDF
Format](#)

[Click here to make tpub.com your
Home Page](#)

Page Title: 14182
[Back](#) | [Up](#) | [Next](#)

[tpub.com Updates](#)



Web

www.tpub.com

[Home](#)

Information Categories

[Administration](#)

[Advancement](#)

[Aerographer](#)

[Automotive](#)

[Aviation](#)

[Combat](#)

[Construction](#)

[Diving **New**](#)

[Draftsman](#)

[Engineering](#)

[Electronics **New**](#)

[Food and Cooking **New**](#)

[Math](#)

[Medical](#)

[Music](#)

[Nuclear Fundamentals](#)

[Photography](#)

[Religion](#)

[USMC](#)

[Chapter 1 Wave Propagation](#)

- [Principles Of Wave Motion](#)
- [Wave Motion In Water](#)
- [Figure 1-1.—Formation Of Waves In Water](#)
- [Transverse Waves](#)
- [Medium](#)
- [Terms Used In Wave Motion](#)
- [Cycle](#)
- [Characteristics Of Wave Motion](#)
- [Figure 1-8.—Longitudinal Wave Represented Graphically By A Transverse Wave](#)
- [Characteristics Of Wave Motion-Cont.](#)
- [Characteristics Of Wave Motion-Cont.](#)
- [Reflection](#)
- [Refraction](#)
- [Figure 1-10.—Refraction Of A Wave](#)
- [Diffraction](#)
- [Sound Waves](#)
- [Requirements For Sound](#)
- [Characteristics Of Sound](#)
- [The Intensity Of Sound](#)
- [Sound Quality](#)
- [Elasticity And Density And Velocity Of Transmission](#)
- [Acoustics](#)
- [Interference](#)

Products[Educational CD-ROM's](#)[Printed Manuals](#)[Downloadable Books](#)

- [Propagation Of Light](#)
- [Electromagnetic Theory Of Light](#)
- [Frequencies And Color](#)
- [Properties Of Light](#)
- [Figure 1-20.—Transparent, Translucent, And Opaque Substances](#)
- [Reflection Of Light](#)
- [Diffusion Of Light](#)
- [Comparison Of Light Waves With Sound Waves](#)
- [Electromagnetic Spectrum](#)
- [The Basic Antenna](#)
- [Components Of The Electromagnetic Wave](#)
- [Electric Field](#)
- [Figure 1-26.—Electric Fields Between Plates At Different Angles](#)
- [Magnetic Field](#)
- [Figure 1-28.—Magnetic Fields Around Elements](#)
- [Combined Electric And Magnetic Fields](#)
- [Summary](#)
- [Longitudinal Wave](#)
- [Law Of Reflection](#)
- [Doppler Effect](#)
- [Primary Colors](#)
- [Answers To Questions Q1. Through Q48](#)
- [Answers To Questions Q1. Through Q48](#)

Chapter 2 Radio Wave Propagation

- [Electromagnetic Fields](#)
- [Figure 2-2.—Phase Relationship Of Induction Field Components](#)
- [Radiation Fields](#)
- [Figure 2-3.—Radiation From An Antenna](#)
- [Radio Waves](#)
- [Table 2-1.—Radio Frequency Bands](#)
- [Wavelength-To-Frequency Conversions](#)
- [Wavelength-To-Frequency Conversions-Cont.](#)
- [Polarization](#)
- [Atmospheric Propagation](#)
- [Refraction](#)
- [Diffraction](#)

- [The Effect Of The Earth's Atmosphere On Radio Waves](#)
- [Radio Wave Transmission](#)
- [Surface Wave](#)
- [Space Wave](#)
- [Structure Of The Ionosphere](#)
- [Four Distinct Layers](#)
- [Refraction In The Ionosphere](#)
- [Density Of Layer](#)
- [Angle Of Incidence](#)
- [Figure 2-18.—Effects Of Frequency On The Critical Angle](#)
- [Skip Distance/Skip Zone](#)
- [Absorption In The Ionosphere](#)
- [Fading](#)
- [Transmission Losses](#)
- [Ground Reflection Loss](#)
- [Control Of Emi](#)
- [Eleven-Year Sun Spot Cycle](#)
- [Sporadic E](#)
- [Frequency Selection Considerations](#)
- [Optimum Working Frequency](#)
- [Weather Versus Propagation](#)
- [Temperature Inversion](#)
- [Tropospheric Propagation](#)
- [Tropospheric Scattering](#)
- [Summary](#)
- [Vertically Polarized](#)
- [Troposphere](#)
- [Sky Waves](#)
- [Critical Frequency](#)
- [Skip Zone](#)
- [Multipath Fading](#)
- [Optimum Working Frequency \(Fot\)](#)
- [Answers To Questions Q1. Through Q48](#)
- [Answers To Questions Q1. Through Q48](#)

[Chapter 3 Principles Of Transmission Lines](#)

- [Terminology](#)

- [Two-Wire Open Line](#)
- [Shielded Pair](#)
- [Figure 3-6.—Air Coaxial Line.](#)
- [Waveguides](#)
- [Losses In Transmission Lines](#)
- [Dielectric Losses](#)
- [Length Of A Transmission Line-Cont.](#)
- [Transmission Line Theory](#)
- [Distributed Constants](#)
- [Capacitance Of A Transmission Line](#)
- [Electromagnetic Fields About A Transmission Line](#)
- [Characteristic Impedance Of A Transmission Line](#)
- [Characteristic Impedance And The Infinite Line](#)
- [Characteristic Impedance And The Infinite Line-Cont.](#)
- [Figure 3-17.—Termination Of A Line.](#)
- [Voltage Change Along A Transmission Line](#)
- [Ac Applied To A Transmission Line](#)
- [Dc Applied To An Infinite Line](#)
- [Ac Applied To An Infinite Line](#)
- [Figure 3-21.—Ac Applied To An Equivalent Transmission Line.](#)
- [Figure 3-22.—Instantaneous Voltages Along A Transmission Line](#)
- [Velocity Of Wave Propagation](#)
- [Figure 3-23.—Dc Applied To An Equivalent Transmission Line](#)
- [Determining Characteristic Impedance](#)
- [Determining Characteristic Impedance-Cont.](#)
- [Reflection Of Dc Voltage From An Open Circuit](#)
- [Figure 3-24.—Reflection From An Open-Ended Line.](#)
- [Reflection Of Dc Voltage From A Short Circuit](#)
- [Figure 3-25.—Reflection From A Short-Circuited Line](#)
- [Reflection Of Ac Voltage From An Open Circuit](#)
- [Reflection Of Ac Voltage From An Open Circuit-Cont.](#)
- [Figure 3-27.—Instantaneous Values Of Incident And Reflected Waves On An Open-Ended Line](#)
- [Figure 3-28.—Conventional Picture Of Standing Waves](#)
- [Figure 3-29.—Composite Results Of Instantaneous Waves](#)
- [Reflection Of Ac Voltage From A Short Circuit](#)
- [Terminating A Transmission Line](#)
- [Figure 3-31.—Sending-End Impedance Of Various Lengths And](#)

- [Terminations](#)
- [Impedance For Various Lengths Of Open Lines](#)
- [Figure 3-32.—Voltage, Current, And Impedance On Open Line](#)
- [Impedance Of Various Lengths Of Shorted Lines](#)
- [Standing Waves On A Transmission Line](#)
- [Termination In An Open Circuit](#)
- [Termination In Inductance](#)
- [Termination In A Resistance Less Than \$Z_0\$](#)
- [Voltage Standing-Wave Ratio](#)
- [Summary](#)
- [Shielded Pair](#)
- [Copper Losses](#)
- [Leakage Current](#)
- [Characteristic Impedance, \$Z_0\$](#)
- [Short-Circuited](#)
- [Nonresonant](#)
- [Terminations](#)
- [Standing Wave Ratio](#)
- [Answers To Questions Q1. Through Q30](#)
- [Answers To Questions Q1. Through Q30](#)

[Chapter 4 Antennas](#)

- [Principles Of Antenna Radiation](#)
- [Figure 4-2.—Typical Antenna System](#)
- [Current And Voltage Distribution On An Antenna](#)
- [Figure 4-4.—Current And Voltage Distribution On An Antenna](#)
- [Radiation Of Electromagnetic Energy](#)
- [Figure 4-6.—Standing Waves Of Voltage And Current On An Antenna](#)
- [Antenna Characteristics](#)
- [Polarization](#)
- [Polarization Requirements For Various Frequencies](#)
- [Advantages Of Vertical Polarization](#)
- [Radiation Resistance](#)
- [Isotropic Radiation](#)
- [Rectangular-Coordinate Pattern](#)
- [Anisotropic Radiation](#)

- [Figure 4-11.—Anisotropic Radiator](#)
- [Antenna Loading](#)
- [Basic Antennas](#)
- [Radiation Patterns](#)
- [Radiation Pattern Of A Dipole](#)
- [Methods Of Feeding Energy To An Antenna](#)
- [Characteristics Of Quarter-Wave Antennas](#)
- [Figure 4-19.—Groundscreen And Counterpoise](#)
- [Folded Dipole](#)
- [Array Antennas](#)
- [Phasing](#)
- [Stub Phasing](#)
- [Directivity](#)
- [Directional Arrays](#)
- [Radiation Pattern](#)
- [Broadside Arrays](#)
- [Gain And Directivity](#)
- [End-Fire Arrays](#)
- [Figure 4-29.—Parallel Elements 180 Degrees Out Of Phase](#)
- [Parasitic Arrays](#)
- [Operation](#)
- [Figure 4-31.—Patterns Obtained Using A Reflector With Proper Spacing](#)
- [Gain And Directivity](#)
- [Yagi Antennas](#)
- [Special Antennas](#)
- [Long-Wire Antenna](#)
- [Rhombic Antenna](#)
- [Advantages](#)
- [Disadvantages](#)
- [Turnstile Antenna](#)
- [Ground-Plane Antenna](#)
- [Rf Safety Precautions](#)
- [Figure 4-43.—Examples Of Rf Radiation Warning Signs](#)
- [Precautions When Working Aloft](#)
- [Radiation Resistance](#)
- [Anisotropic Radiator](#)
- [Antenna Loading](#)

- [Quarter-Wave Antenna \(Marconi\)](#)
- [Folded Dipole](#)
- [End-Fire Array](#)
- [Parasitic Array](#)
- [Beverage Antennas](#)
- [Turnstile Antenna](#)
- [Answers To Questions Q1. Through Q48](#)
- [Answers To Questions Q1. Through Q48](#)

[Glossary](#)

- [Glossary](#)
- [Glossary](#)
- [Glossary](#)
- [Glossary](#)
- [Glossary](#)
- [Glossary](#)
- [Glossary](#)
- [Glossary](#)
- [Glossary](#)
- [Glossary](#)

[Module 10 Index](#)

- [Module 10 Index](#)
- [Module 10 Index](#)

[Assignment Questions](#)

- [Assignment Questions](#)
- [Assignment Questions](#)
- [Assignment Questions](#)
- [Assignment Questions](#)
- [Assignment Questions](#)
- [Assignment Questions](#)
- [Assignment Questions](#)
- [Assignment Questions](#)
- [Assignment Questions](#)
- [Assignment Questions](#)



This page last updated on 19 October 2001 at 20:37:00

[Home](#) | [ATV](#) | [ATV Centre](#) | [Schools](#) | [Fenton Relay](#) | [Antenna Theory](#) | [Other Pages](#)

Basic Antenna Theory

Radio waves are generated by electrons accelerating in the antenna.

Consider a transmitter perpendicular to the ground. The electrons in the antenna, when a signal is applied, are changing their velocities continuously (i.e. moving up and down very quickly) in response to the applied signal.

For a station that broadcasts at a wavelength of 1500m, the antenna needs to be 750m long. This is because there is a 'virtual antenna' caused by the aerial being earthed in the ground:

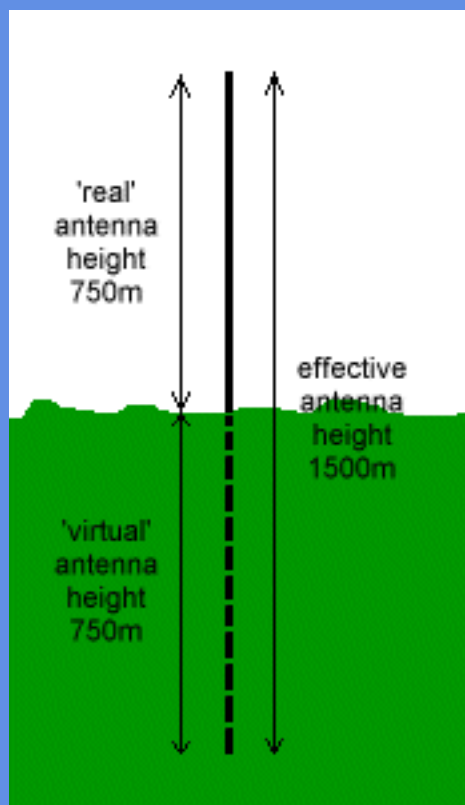

The transmitting aerial (and the receiving aerial) need only be half-the-wavelength tall.

Now if this transmitter has no directional properties (i.e. it radiates in all directions equally), it has a coverage area, assuming completely flat ground, that is a perfect circle:

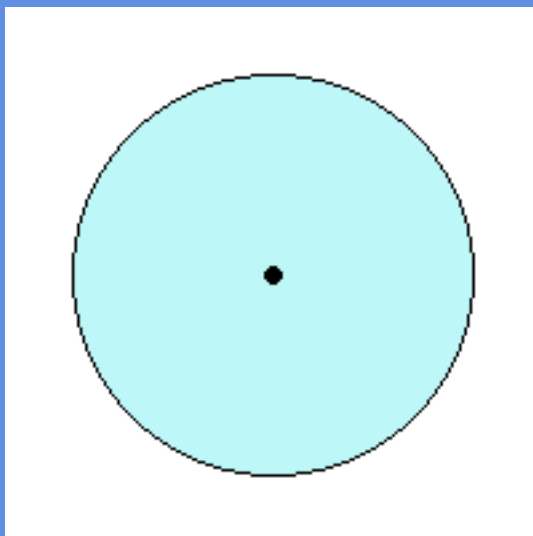

(View from above - antenna in centre; blue is coverage area)

Broadcasters rarely use a non-directional aerial though. It is possible to 'force' the energy radiated by the transmitter into particular directions - the aerial becomes directional. Directional aerials are used to great effect near the coasts of the UK, where the broadcasters do not want their signal to be easily picked up on the continent.

It is important that signal doesn't leak onto the continent since i) continental stations use the same frequencies and leaking signal would cause interference and ii) some programme broadcast rights apply to the UK only.

Under unusual weather conditions, despite the best efforts of broadcasters both in this country and abroad, signals travel much further than they normally would and interfere with reception of stations using the same channel, causing co-channel interference.

Let's switch the emphasis from the transmitting aerial to the receiving aerial. Similar principles apply for receiving aerials as for transmitters as above.

The Half-Wave Dipole

There is only one part of a receiving aerial that is active, i.e. does the receiving and is connected to the TV/radio set. This active element is called the dipole. The simplest design of antenna would consist of a dipole only:

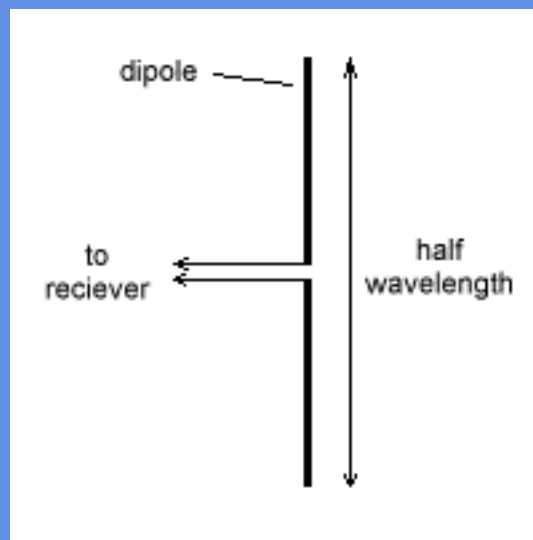

A half-wave dipole

In the diagram above, there are two wires marked 'to receiver.' For UHF and VHF, one wire will be the copper-core and the other the copper braiding of a co-axial cable.

Before we proceed, a quick word about gain. Although having a technical definition, for us 'gain' can mean "the effectiveness with which a receiving aerial receives a signal."

The diagram below shows the reception pattern of a half-wave dipole. The blue area is where the gain is higher than a certain value; the dipole is in the centre:

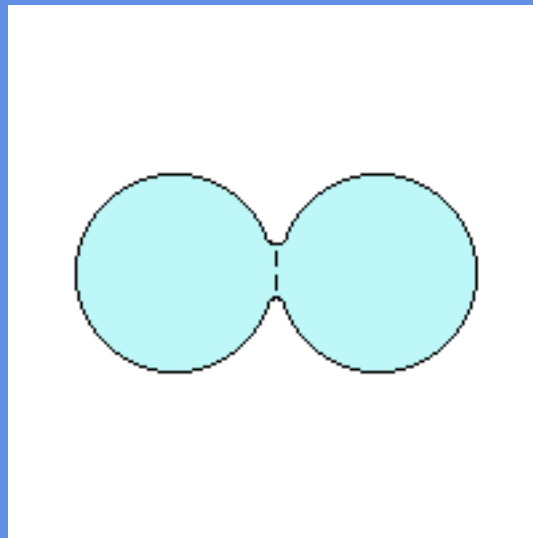

We can change the directivity of the aerial by adding other elements. Any other elements that we add to the basic half-wave dipole are called passive elements and are not connected electrically to the dipole.

There are two types of passive elements:

Directors

Directors alter the directivity of the aerial so that the aerial's gain is improved in front of the dipole. Most aerials have

more than one director, and the more directors the aerial has the better the aerial is at picking out the signal from the required source and rejecting signals from other angles.

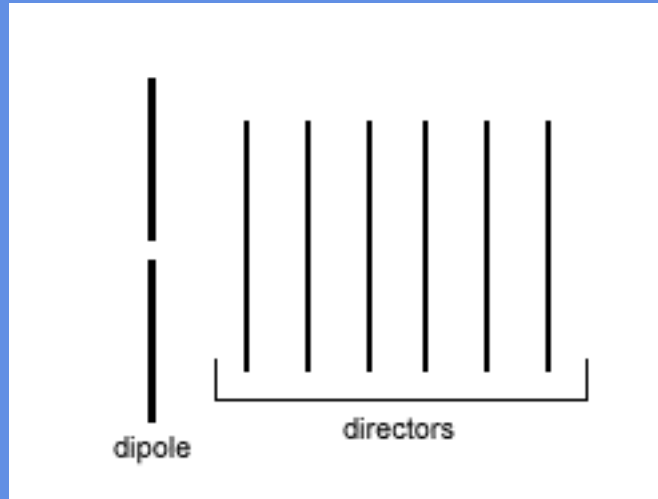

These diagrams do not show the cross-bar that holds all the elements in place as it does not much affect the characteristics of the aerial.

The spacing between the directors, diameter of the tubing used and the spacing between the first director and the dipole are important in practice but will be disregarded here. The length of the directors governs the bandwidth of the aerial (over which channels it is effective), but suffice it to say that it is about 75% the length of the dipole.

The gain of the dipole with directors in place looks like this:

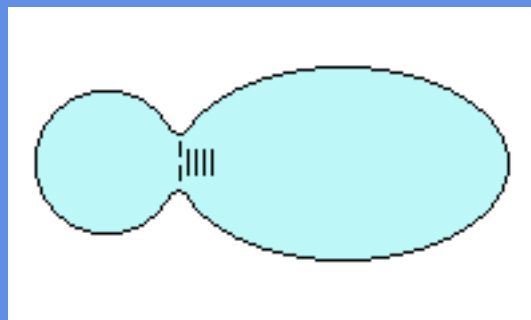

Notice how the gain is now more focused in the direction of the directors.

As stated earlier, the more directors an aerial has the more focused the gain is in the direction of the directors. Every new director added becomes less effective though, and in practice it is only worth adding 18-20 directors to the aerial, as any more than this wouldn't increase the gain very much.

On the diagram above, the aerial still has some gain at the rear - in other words, it can still receive signals from behind. This is known as a low front-to-back ratio.

The Reflector

To improve the front-to-back ratio we can add the second type of passive element, a reflector. The reflector reflects signal coming in from the back of the aerial whilst improving the forward gain.

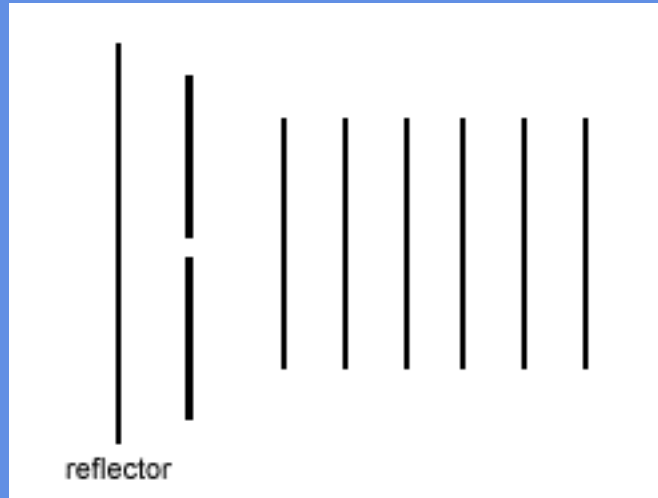

This design is called a Yagi-Uda array, after its creators.

Again, the length, size and position of the reflector affect the aerial's properties, but we won't go into that here.

The reflector can take the shape of a metal plate (with holes in it, making the aerial more impervious to wind) or several rods spaced equidistant from the centre of the dipole.

The result is that there is less gain behind the aerial and more, where we want it to be, in front:

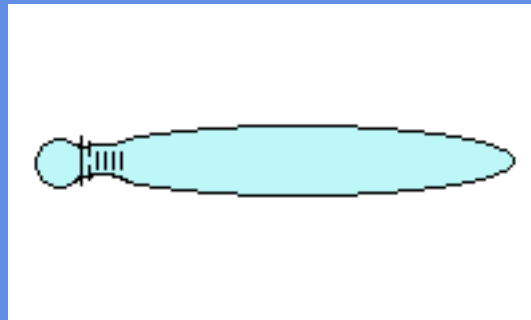

Folded Dipoles

In order to minimise signal loss it is important that the impedance (a sort of resistance for AC) of the dipole matches that of the feeder cable and the receiving set.

The impedance for the type of dipole discussed above is about 75 ohms. More often than not though the impedance needs to be altered to match the cable and receiving set characteristics.

This change of impedance is achieved by folding a rod over so that its folded length is still half-a-wavelength:

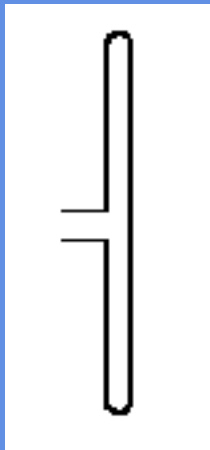

Now we know what each constituent part of an aerial is called and what its function is, let's look at some examples in the field.

[Next >](#)
[< Prev](#)

[The Electromagnetic Spectrum](#)
[Practical Examples of Aerial Design](#)

[Back to sub-TV home](#)

8758

since 8th March 2001

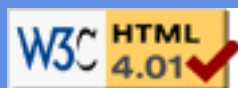



Find on this site...

[Site Index](#)

•[Exams](#) Search site: Call sign search:
 •[Clubs](#)
 •[Hamfests](#)
 •[Addresses](#)

ARRL Member Login...

Username: Password:

[Register](#)

Quick Links...

•[Join or Renew](#)
 •[Catalog & Store](#)
 •[ARRL Courses](#)
 •[Classifieds](#)
 •[Getting Started](#)

[Operating Activities](#) [Licensing](#) [News/Bulletins](#) [Services](#) [Educational](#) [Public Service](#) [Support](#) [Donate to ARRL](#) [ARRL Info](#) [Text-only/Printable](#)

Why an Antenna Radiates

You don't have to know how an antenna works to use one, but getting a handle on this subject can deepen your understanding of radio. Here's a searching look at the mysterious process by which our antennas hurl energy from Here to There.

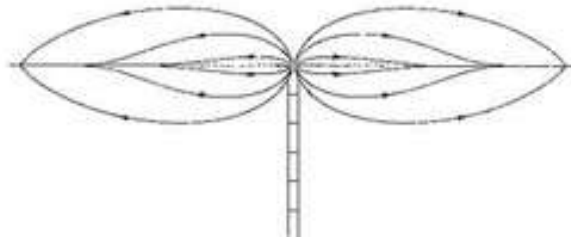

By Kenneth Macleish, W7TX
QST November 1992

If antennas didn't radiate, we might be well advised to dispose of our ham gear and take up another hobby. Fortunately, they *do* radiate. Our purpose here is to explore the basic principles underlying this wonderful and little-understood phenomenon.

Before starting, let's try a simple test to see how much you already know about antennas. Don't peek at the answers¹ until you have answered all the questions!

1. In a center-fed, half-wave dipole, electrons surge back and forth from one side of the antenna to the other.

True ___ False ___

2. It is possible for a perfect insulator to radiate.

True ___ False ___

3. Unlike ohmic resistance, "radiation resistance" has significance only at the feed point of an antenna or antenna system.

**ARRL Products:
 Pins, Patches, Maps, Gift
 Ideas & Supplies...**
[\(More\)](#)



NTS Mug --

Ceramic mug (10 oz) with colorful logo of the National Traffic System (NTS).



**ARRL Life Member
 Decal** -- Unique

design to show off your ARRL life membership.



**ARES Magnetic
 Sign** -- **Now**

Shipping! -- This eye-catching, flexible magnetic sign is perfect for use at public service and emergency communications support activities.



**The ARRL World
 Grid Locator Atlas** -

- Containing all 32,400 Maidenhead Locator Squares.

True ___ False ___

4. The ground around a transmitting antenna radiates.

True ___ False ___

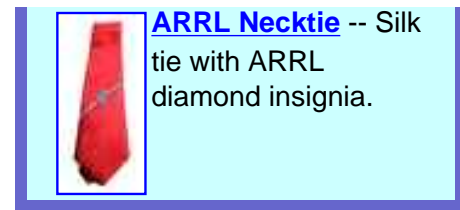

If you got all the answers right, you probably know more than the writer, and you have permission to skip the rest of this article.

An Imaginary Experiment

Take a pithball about the size of a marble between your thumb and forefinger. If you don't know what a pithball is, or can't find one, a hunk of plastic foam or a ping pong ball will be fine. For lack of a better name we will refer to any of these articles as a pithball. Rub the pithball on your carpet to give it a good electrical charge. Now wave the pithball back and forth in the air over a six-inch distance as fast as you can. The pithball is sending out electromagnetic waves! Let's say you are achieving a rate of 10 cycles of motion per second. If you have placed in the corner of the room a sufficiently sensitive megameter-wave receiver, it will detect a signal when tuned to a frequency of 10 hertz, or to a wavelength of 30 million meters. If you could vibrate your hand fast enough you might even be able to carry on radio communication in this fashion!

We will continue this experiment shortly. Meanwhile let's take a look at what goes on inside an antenna.

Put Your Antenna Under a Microscope

Now, admittedly the average antenna doesn't contain any pithballs. But it does contain hordes of minute, lightweight, electrically charged particles called *electrons*. Many of these are so-called *free* electrons that have broken loose from their parent copper or aluminum atoms and are able to travel more or less freely through the spaces between atoms, under the influence of any electric fields that may be present. The free electrons behave in many ways like tiny pithballs.

We know that an electric current in a conductor is simply a mass migration of free electrons. If the current is alternating, as in an antenna, the free electrons in a given locality move back and forth in unison. Evidently, then, any individual electron moves to and fro around an average position, like the pithball in our experiment. Let's see how far and how fast this electron might travel.

Consider an antenna made of #12 copper wire and operating at 14.1 MHz. Each free electron near the surface of the wire is executing 14.1 million cycles of motion per second. Knowing the number of free electrons per cubic inch of copper, the electric charge on each, and the depth of RF penetration into the wire (the *skin depth*), we can calculate the peak speed of an electron at a place where the RMS antenna current is, say, one ampere. The result comes out to be less than half an inch per second. At that rate the electron doesn't move very far during each half cycle of vibration: its peak-to-peak travel is no more than a hundred-millionth of an inch. In the eyes of an electron this distance is quite respectable, being tens of thousands of times its own diameter. The answer to question 1 above, though, is clearly "False." Not one electron makes it through the feed system from one side of the antenna to the other.

We can compute the electron's deceleration and acceleration, which are greatest when the electron is coming to a stop and then starting up in the other direction. At an antenna current of one ampere, these quantities reach more than 50,000 gs! And an accelerating or decelerating charged body, be it an electron or a pithball, is a source of

electromagnetic radiation.

A pithball is a pretty good insulator, and so, presumably, is an electron. So the answer to question 2 is "True": a perfect insulator *can* radiate.

Let's return to our imaginary experiment. This time, instead of waving a pithball at 10 hertz, we'll pretend to vibrate a single electron at radio frequency² and examine the resulting fields.

Fields of a Vibrating Electron

The detailed structure of an electron is unknown, but for our purposes it doesn't matter; we can assume that our electron is a little round ball with an electrical charge distributed uniformly over its surface. We determine the fields by solving Maxwell's equations³ at all distances from the electron, right down to its surface. This analysis is not an exercise for the faint-hearted. We'll skip the details and concentrate here on the results.

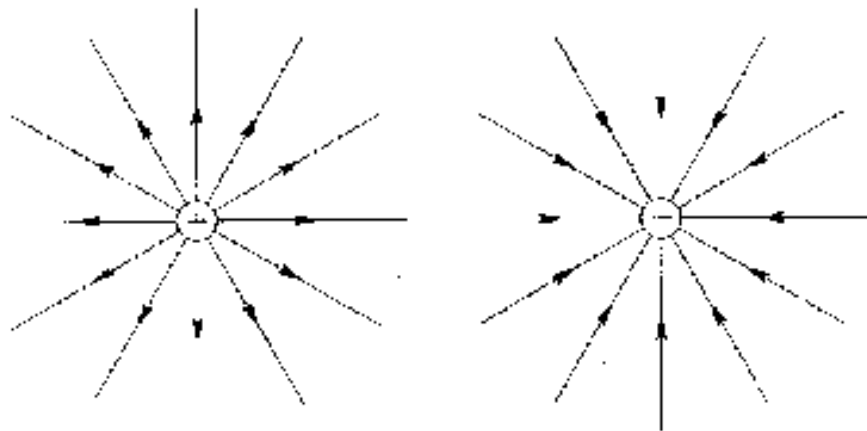

Fig 1 -- Always present around a charged particle, the coulomb field plays a vital role in energy radiation.

The Coulomb Field

Grasping the electron in, say, a tiny pair of tweezers, let's start by holding it still. After a while the only field present will be a stationary electric field that points outward⁴ in all directions from the electron. The field lines take the form illustrated in Fig 1 for both positive and negative charges. This is called the *coulomb field*. It is always present, regardless of whether the electron is in motion. We'll find later that the coulomb field plays a vital role in the operation of antennas.

With vibratory motion, two new fields make their appearance.

The Magnetic Field

A moving electron constitutes a current, and a current is always surrounded by a *magnetic field*. As if hitchhiking, point the thumb of your right hand in the direction of the electron's motion; then your curled fingers represent the circular lines of the magnetic field around the electron. Point your thumb in the opposite direction and you see that the

magnetic field reverses, so a vibrating electron gives rise to an alternating magnetic field. At the electron's surface, the magnetic field is almost exactly in phase with the electron's speed, but as we move away, the phase of the magnetic field begins to lag. Out to a radius of $1/6$ wavelength, the phase lag is small. Beyond this radius, the lag starts to increase at a more rapid rate and soon settles at 360 degrees per wavelength of distance.

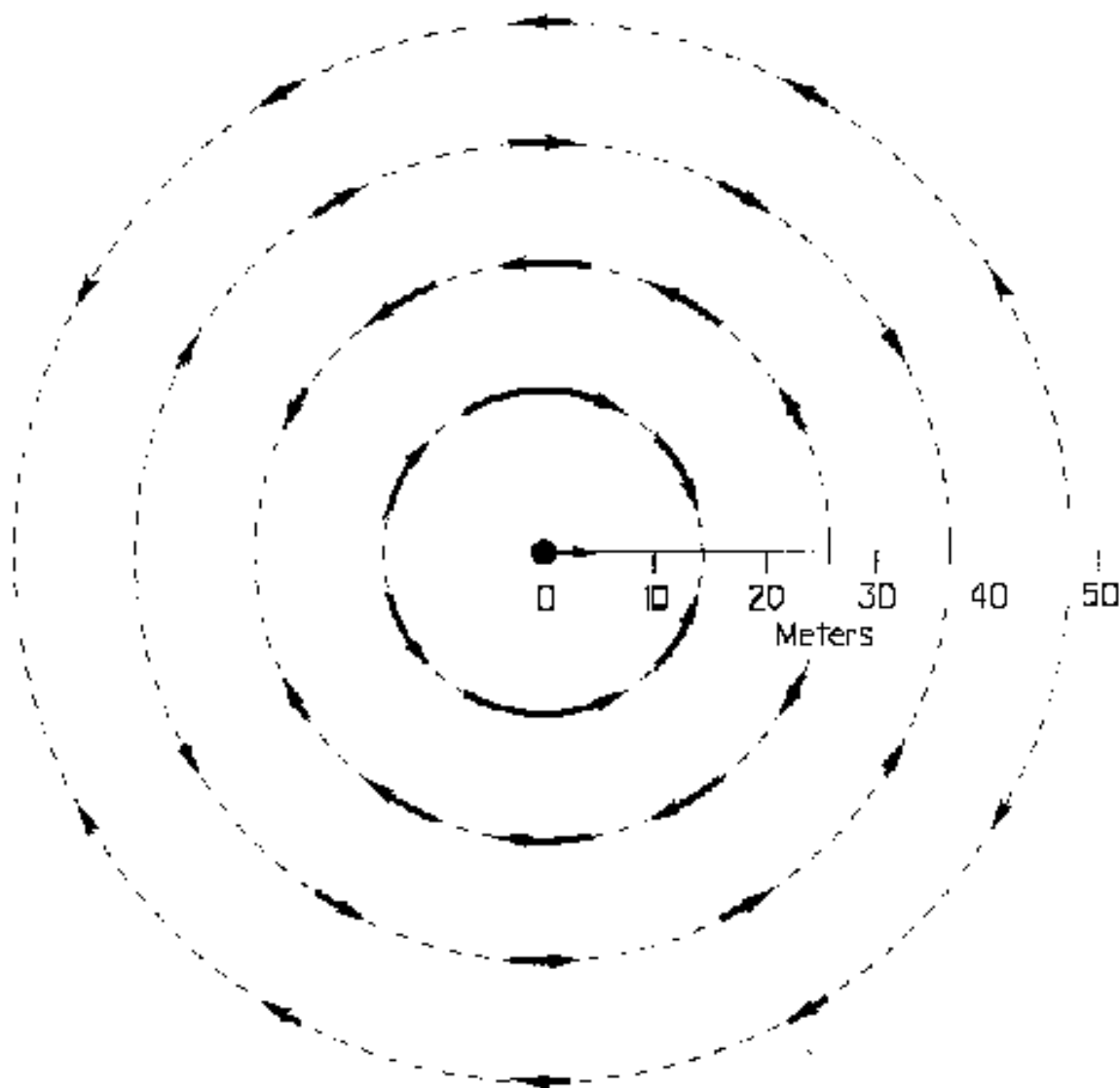

Fig 2 -- The radiation field of an electron vibrating as 14.1 MHz. Each broken line represents a wave crest.

The Dynamic Electric Field

The second new field is an electric field that results from the electron's acceleration. Because of its dynamic origin -- in contrast to the electrostatic nature of the coulomb field -- we'll call this field the *dynamic electric field*. It's useful to regard the dynamic electric field as the sum of two separate fields, one of which is in phase with the magnetic field and the other 90 degrees out of phase. We will call the in-phase component the *radiation field* and the out-of-phase component the *induction field*. It is the radiation field that carries energy from an antenna into the surrounding universe.

Fig 2 shows an area the size of a football field in which a lone electron, greatly magnified, is being vibrated at 14.1 MHz. The figure is a snapshot of the electron's radiation field taken at an instant when the electron is at the center of its travel and moving to the right, as indicated by an arrow. The curved arrows show the direction and strength of the radiation field. The dashed circles represent spherical wavecrests on which the field is at a local maximum. As we go outward from a wavecrest, the field decreases to zero, then reverses and rises again to the next wavecrest. Like ripples in a cosmic pond, these spherical waves are expanding outward at the speed of light, 300 million meters per second.

At any one point, the radiation and induction fields vary as sine-wave functions of time. About $1/6$ wavelength away from the electron (actually $1/[2\pi]$ wavelength), in a direction at right angles to the line of motion, the two fields are equal in amplitude. As we move farther away, the induction field falls off so much more rapidly than the radiation field that we soon have essentially nothing but the radiation field. Inside a vacuum-dielectric coaxial transmission line carrying power in one direction, the ratio of the electric to the magnetic field is equal to 377 ohms. In our pure radiation field, which carries power in the same manner even though there are no physical conductors present, this ratio is likewise equal to 377 ohms—a value that is sometimes called the characteristic impedance of space.

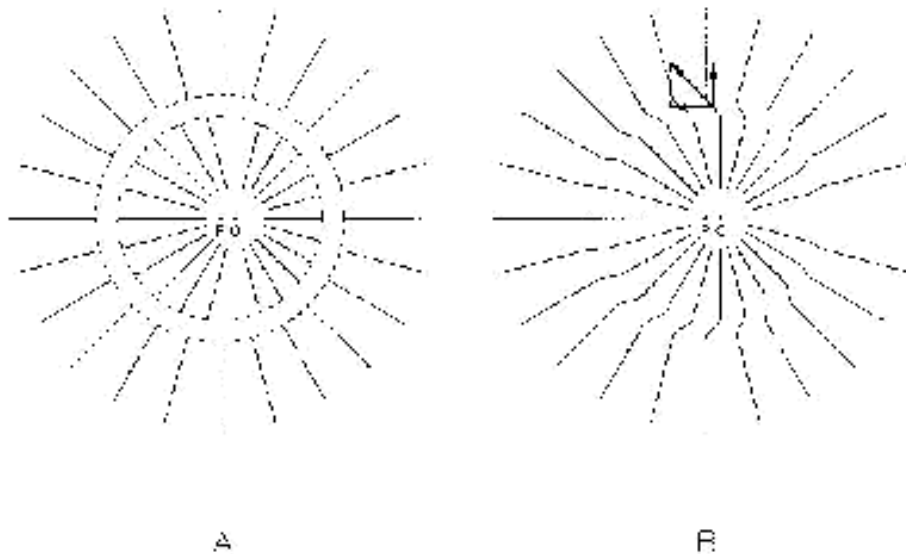

Fig 3 -- The electric field of an electron that was accelerated recently. The resulting disturbance in the field is traveling outward at the speed of light. The transverse component of the disturbed field is the radiation field.

Why an Accelerating Electron Radiates

We've described the radiation field of a vibrating electron, but we haven't yet explained why it happens. The answer is hidden in Fig 3A.

Suppose that, until a short while ago, an electron was held at rest at point P in Fig 3A. It was then accelerated briefly to the right by our tweezers and afterward was kept moving to the right at constant speed. At the present time (which we'll call time zero), the electron is passing point Q.

Fig 3A contains two circles. The larger circle (the outermost broken line) is centered at P and has radius equal to the distance light would travel in the interval from the beginning of acceleration until time zero. The smaller circle is

centered at the spot occupied by the electron at the end of acceleration; its radius is equal to the distance light would travel between the *end* of acceleration and time zero. As time marches on, the circles evidently grow at the speed of light. The space between the circles is equal to the distance light would travel during the period of acceleration. If the electron moves slowly in comparison with light, as it does in an antenna, the distance it covers during acceleration is small compared to the size of the circles, so the circles are nearly concentric. For clarity we have greatly exaggerated the distance PQ; it too would be very small if drawn to scale. Now we can determine what the electric field must look like at time zero.

Outside the larger circle, the field at time zero is a stationary coulomb field centered on P, as if the electron had never started to move.⁵ Inside the smaller circle, the field is a moving coulomb field centered on the electron's present position, point Q. Between the circles the field is intermediate between the fields in the other two regions.

Now connect the field lines across the space between the circles and erase the circles, making Fig 3B. You can see that the electron, while accelerating, gave birth to an expanding electromagnetic disturbance. In the disturbed region, as shown by the arrows, there is a transverse field component -- the radiation field -- in addition to the outward-pointing coulomb field.

The radiation field resulting from a *vibrating* electron, Fig 2, is simply a continuous series of such disturbances caused by successive intervals of changing acceleration and deceleration.

The Bootstrap Forces

The radiation and induction fields of a vibrating electron exist right down to the electron's surface. Since the electron's surface carries an electric charge, and since an electric charge is pulled by an electric field, it's fair to ask whether these fields are able to exert forces on the very electron that is producing them. In other words, can an electron "feel" its own dynamic electric field? The answer is yes. The electron is pulled by its own bootstraps! The tweezers that are providing the motive power must overcome the bootstrap forces.⁶

The bootstrap forces are responsible for two very important properties of a conductor: radiation resistance and inductance.

Radiation Resistance Versus Ohmic Resistance

By our definition, an alternating radiation field is in phase with the accompanying magnetic field. At the surface of a vibrating electron the magnetic field is essentially in phase with the electron's speed, so here the radiation field, and the bootstrap force exerted by it, are likewise in phase with this speed. The direction of the force is such as to resist the electron's motion. It is evident that the force feels to our tweezers like a drag proportional to speed, as if the electron were moving through a viscous fluid. This drag force is the cause of radiation resistance.

An electron moving in a conductor also feels a drag force that is due to frequent progress-impeding collisions between the electron and the atoms in its path. This drag is the cause of ohmic resistance, the familiar R in Ohm's Law.

Both kinds of resistance dissipate energy at a rate equal to the resistance times the square of the current. Of course, energy dissipated this way doesn't actually disappear. An alternating current, flowing against *radiation* resistance, turns electrical energy into radiant energy, which wings its way off into space. Current flowing against *ohmic* resistance transforms electrical energy into heat, which is mechanical vibration of the atoms of the conductor -- the atoms vibrate when they're hit by the moving free electrons.

Radiation resistance varies along the length of an antenna wire, but it is independent of the diameter and material of the conductor. The middle third of a half-wave, 14.1-MHz dipole has a radiation resistance of 3.7 ohms per foot. That's nearly 80 times the ohmic resistance of clean #12 copper wire at this frequency. Closer to the ends of the antenna, the radiation resistance is even higher.

Inductance

At the surface of a vibrating electron, the induction field, being 90 degrees out of phase with the magnetic field, is 90 degrees out of phase with the electron's speed (ie, the current). The bootstrap force of the induction field therefore opposes *the rate of change of current* rather than the current itself. Here we see the underlying cause of the property of inductance. In reacting to this bootstrap force our tweezers deliver energy *to* the electron during acceleration and receive back an equal amount of energy *from* the electron during deceleration. The delivered energy is stored in the magnetic field around the moving electron and is returned when the magnetic field collapses as the electron slows down.

Because the bootstrap force of the induction field is proportional to acceleration, it feels to the tweezers just like mechanical inertia. In consequence the electron has an *effective inertial mass* that greatly exceeds its gravitational mass.

Now let's step back and look at the fields in and around an entire antenna. You will recognize that the basic principles involved apply to any kind of antenna. Because of its simplicity, we will use an isolated, center-fed, half-wave dipole as an example.

The Big Picture

If our antenna doesn't contain any pithballs, it doesn't contain any tweezers either. What is it, then, that causes the free electrons to vibrate? In real life it takes an electric field to move an electron. Inside an isolated straight dipole, the motive power comes from the combined coulomb fields of all the charged particles, positive and negative, in the antenna. We'll refer to this combined field as the *antenna's coulomb field*.

In addition to the coulomb field, the antenna as a whole exhibits a magnetic field that is the sum of the magnetic fields of all the moving free electrons. It also sports a dynamic electric field that is the vector sum of the dynamic electric fields of all the free electrons. As we did with an individual electron, we can separate the dynamic electric field of the antenna at any point in space into two components, one in phase with the total magnetic field and the other 90 degrees out of phase. We will call the in-phase component the radiation field of the antenna and the out-of-phase component the induction field. Right at the antenna, both fields are parallel to the metal surface.

It happens that the coulomb field and the induction field fall off much more rapidly than the radiation field with increasing distance from the antenna. At distances greater than a few wavelengths from the antenna, in what is called the antenna's *far field*, the electric field is essentially pure radiation.⁷ Closer to the antenna, we have the *near field*, which is a mixture of the radiation, induction and coulomb fields.

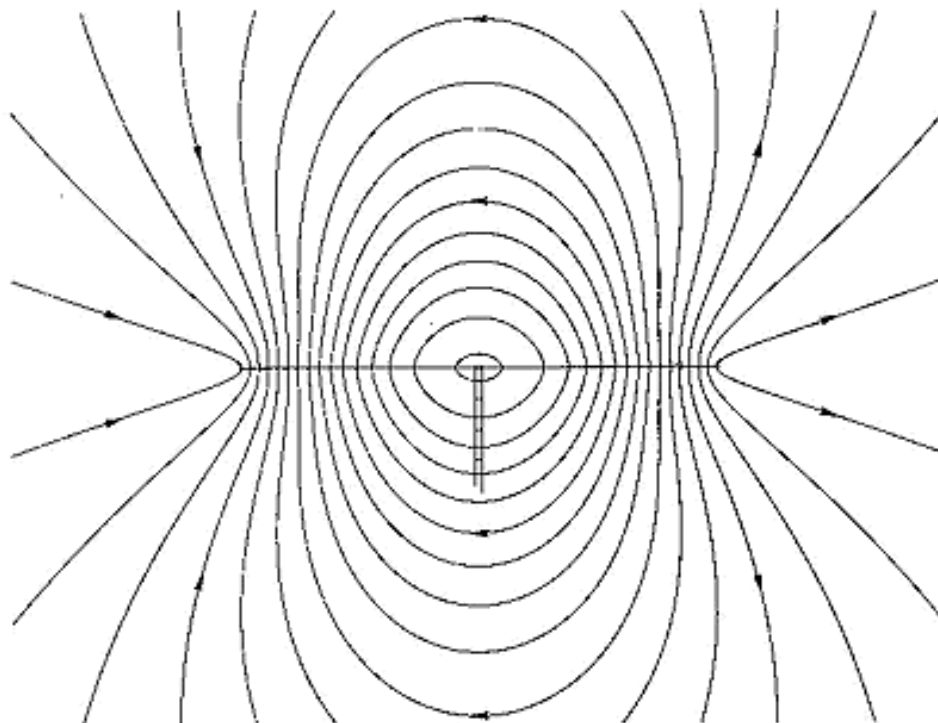

Fig 4 -- The coulomb field at an instant in time around a half-wave resonant dipole. A half-cycle later, the polarity, and all the arrows, will be reversed. The spacing between the field lines indicates field strength.

Action of the Coulomb Field

We see in Fig 4 a snapshot of the coulomb field near the antenna. This picture shows an instant in time when the right-hand half of the antenna is positively charged and the left-hand half is negatively charged, as a result of a process that we'll examine in a moment. A half-cycle later, the polarity, and all the arrows, will be reversed. The spacing between the field lines indicates field strength. At the antenna wire or tubing, the field lines are nearly, but not exactly, perpendicular to the metal surface.

On alternating halves of the antenna, the perpendicular component of the coulomb field tries to pull electrons out of the surface. This effort is generally unsuccessful in amateur antennas because the "work function" for copper or aluminum -- the energy it takes to dislodge an electron from the surface -- is too great. If the transmitter power is very high, though, the field may be strong enough to pull electrons out into the air. The result is an exciting (but power-wasting) luminous display called *corona*. But because the coulomb field leans slightly away from the perpendicular at the antenna's surface, it can always pull free electrons *along* the surface.

At one point in the RF cycle, free electrons throughout the antenna are moving to the right at or near their maximum speed. The right-hand half of the antenna thereupon begins to accumulate an excess of electrons, even if no single electron will shift to the right by more than a hundred-millionth of an inch. In the left-hand half of the antenna the departure of free electrons leaves an equal excess of oppositely charged metal ions, which are stationary atoms that have lost an electron. The coulomb field produced by this increasing imbalance of charges now opposes the electrons' rightward motion. By virtue of their effective mechanical inertia (also known as the bootstrap force of their induction field), the electrons coast for a while against the rising force of the coulomb field, which eventually brings them to a

stop and then propels them back toward the left. After the electrons again reach maximum speed, now in the opposite direction, the foregoing scenario is repeated with left and right interchanged. The end result is the vibratory motion of free electrons that causes them to heat the metal and generate electromagnetic waves.

Newton's second law of motion tells us the relationship between the acceleration of an electron and the sum of the forces acting on it. In this case, one of the forces is the pull of the coulomb field parallel to the metal surface. The other two forces are the bootstrap force of the dynamic electric field and the drag of ohmic resistance. According to Sir Isaac, the sum of all three forces is equal to the gravitational mass of the electron times its acceleration. We will assume that an electron is so nearly weightless that its gravitational mass can be set to zero in this equation. Then the three forces must always add up to zero.

Turning this statement around another way, we can say that the dynamic electric field and the parallel component of the coulomb field partly cancel each other, the remaining field being just enough to overcome the drag of ohmic resistance. If the ohmic resistance is small enough to be ignored, the coulomb field is precisely equal and opposite to the dynamic electric field everywhere on the surface of an antenna.

This result leads to a procedure, which amounts to the construction and inversion of a matrix, for computing the current distribution on an antenna. Then, using the principles we've been discussing, we can compute the behavior of the system in detail.

Power Flow Through Space

Electrical engineers use the term *real power* for power that flows in one direction past a given point. They also speak of *reactive power*, which is power that flows back and forth in alternating directions with a net flow of zero in any one cycle. The radiation field of an antenna transmits only real power, which travels out toward distant localities without ever reversing direction. The induction field carries only reactive power, and the coulomb field carries both real and reactive power. Again we'll illustrate this with an isolated, center-fed, half-wave dipole.

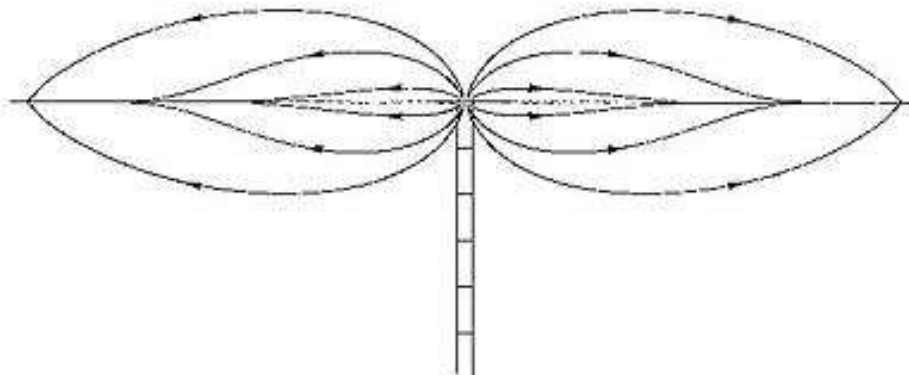

Fig 5 -- Flow of power from the feed point of a half-wave resonant dipole. The coulomb field around the antenna conductors carries power *through the space surrounding the conductors*.

Real Power Flow

How do you suppose your hard-earned RF power gets from the feed point to the rest of the antenna? You might think that it flows out through the wire or tubing of the dipole, but actually this real power is carried *through the*

surrounding space by the coulomb field. Some lines of power flow are plotted in Fig 5.

As you see in the figure, when power coming up the feed line reaches the antenna it spews out into the air in all directions. It then arches to the right and left on curved paths that eventually intersect the antenna. At the points of intersection the coulomb field donates its real power to the free electrons, making up for the energy they are losing to ohmic resistance and radiation resistance.

Reactive Power Flow

During one interval in the RF cycle, the charge on the antenna reaches a maximum, and the current and the magnetic field go through zero. A quarter of a cycle later, the reverse is true. In the first interval, the antenna is surrounded by a cloud of electrostatic energy stored in the coulomb field. In the second interval, the coulomb field has disappeared, and we find the same energy stored in the magnetic field. The energy stored in the coulomb field is used in accelerating the effective inertial mass of the free electrons, which by their motion create the rising magnetic field. Energy thus moves from the coulomb field, via the induction field, to the magnetic field, only to move back again during the next quarter cycle as the magnetic field collapses. This is reactive power flow, with a net of zero.

You can think of the cloud of electrostatic energy as energy stored in the distributed capacitance between the two halves of the antenna. Similarly, the stored magnetic field energy can be thought of as energy residing in the distributed inductance of the antenna wire. If power is suddenly cut off by short-circuiting the feed point, the antenna doesn't stop radiating right away. Instead, it oscillates with diminishing vigor at its resonant frequency until the energy stored in the fields has been dissipated in ohmic resistance and radiation resistance. Our antenna can be accurately described as a resonant circuit made up of distributed capacitance, distributed inductance, and two kinds of distributed resistance.

Antennas and Non-Antennas

What do the following items have in common: a dipole antenna, a radar dish, the ground around a transmitting antenna, a coil and capacitor in parallel, and a wire carrying music to a loudspeaker? One answer: to a greater or lesser degree, they all radiate!

This is true because in operation they all carry time-varying currents and, consequently, accelerating electrons. The dipole antenna is an example of a distributed circuit that owes its existence to the fact that it radiates well. It is designed for efficient conversion of electrical energy into radio waves. But any system of conductors that carries varying currents behaves in accordance with the principles described earlier. The same processes, including radiation, take place whether we call the system an antenna or something else. For example, what we generally refer to as reflection from a conducting surface (the radar dish, the ground) is actually radiation from free electrons set in motion by incident electric fields.

In Sum

Perhaps the foregoing intuitive introduction to classical electromagnetic theory will inspire further development and refinement of the ideas presented. In any event, I hope you'll be able to contemplate an antenna, or a non-antenna, with a warm feeling for all the interesting things going on in and around it!

Notes

¹1--False. 2--True. 3--False. 4--True.

²The classical electromagnetic theory we use in this article is valid at frequencies from dc through microwaves. At still higher frequencies one must venture into the realm of quantum electrodynamics.

³For some pertinent theoretical background see Feynman, Leighton and Sands, *The Feynman Lectures on Physics*, Vol 11 (Addison-Wesley Publishing Co, 1964).

⁴To get an outward-pointing field we must take the charge on the electron to be positive instead of negative as is actually the case. I find it easier to visualize the interaction of electric fields and electrons by thinking of the electron charge as positive. In the end it doesn't make the slightest difference. After all, Ben Franklin, on rubbing an ebony rod with cat's fur, could just as well have defined the charge induced on the cat to be positive. Life might be simpler today if he had.

⁵If you were observing from anywhere outside the larger circle at time zero, the electron would appear to be at point P instead of its actual position, point Q. That's because, according to Einstein's theory of relativity, the news that the electron has started to move can't propagate faster than the speed of light. If you were anywhere inside the smaller circle, the electron would appear at time zero to be in its actual position.

⁶The electron is pulled by its own coulomb field too, but equally in all directions, so the net effect is zero.

⁷In summing the radiation fields at a given point in the far-field region from all the free electrons, we must take into account the differing phases of the source electrons and the varying propagation times. The resulting phase variations cause partial reinforcement or cancellation of the fields, to a degree that depends on direction from the antenna. This effect is the basis of the very extensive subject of antenna radiation patterns, which we will not discuss further here.

Ken Macleish received his first Amateur Radio license 60 years ago at age 12. He now has an Extra Class ticket and still enjoys ham radio, especially CW ragchewing.

He holds a BS in physics (1939) from Caltech and a PhD in physics (1943) from the University of California at Berkeley. He was with Tennessee Eastman Company at Oak Ridge, Tennessee, during World War II, then transferred to Eastman Kodak in Rochester, New York, where his most recent position was assistant director of research and engineering in the Kodak Apparatus Division. In 1962 he joined the Perkin-Elmer Corporation in Norwalk, Connecticut, as a vice president of engineering. He retired in 1970 to enjoy the climate and scenery of Arizona.

Ken has authored QST articles on frequency counters and frequency measurement. Also, over the years, he's had a nagging desire to understand why a radio antenna works. Combining this desire with a background in physics, a hobby of ham radio and an interest in computers, Ken has been working off and on for some time to help dispel some of the mystery surrounding this subject.

Page last modified: 02:37 PM, 06 Oct 2000 ET

Page author: webmaster@arrl.org

Copyright © 2000, American Radio Relay League, Inc. All Rights Reserved.

Embedded Secure Document

The file <http://www.radioelectronicschool.com/reading/reading37.pdf> is a secure document that has been embedded in this document. Double click the pushpin to view.



Construction Practices

KQ6RH

(C) 1998, 1999, 2000

Ray Jurgens

(Up-Dated 2/25/2000)

Introduction

The construction of light weight structures that support wire antennas requires some definite insight into the behavior of the materials. I shall consider only constructions using fiberglass tubes that telescope and the guy lines that are required to stiffen the structures. In some cases, the guy lines are actually the antenna wires, to the mechanical properties of the wires is also important. To understand the structural properties of fiberglass tubing, you should read [Properties of Fiberglass Rods and Tubes](#). This section should give you a first hand understanding of the mechanical properties of this material and a good feel for the amount of bending that can be expected for various diameters and lengths of tubing. The total bending of composite telescoping spreaders made from the standard sizes of tubing can be estimated by considering the loading of the outer most sections at the beginning of the next larger section and working inward so long as the total angle of bending remains small. Small for practical purposes is about 20 degrees. In the case of most light structures, the bending will be more than is desirable, and guy lines will be required to take some the load thus reducing the total bending moment along the beam or spreader. In the end, the maximum loading is controlled by the tendency of the spreader to buckle due to the total force of the guys along the axis of the tubing or rods. This limiting force is easily computed given the geometry and the modulus of elasticity of the material. The remainder of this section considers mostly construction practices that have been found to work well and save time in assembly and disassembly of the antennas. As most of the antennas considered in this web site can be considered as portable, assembly time is often an important factor.

Telescoping Spreaders

The standard tubing sizes available from Max Gain Systems begin at 1/4" OD and work

upward to about 2" in 1/4" increments. The walls are slightly less than 1/8" thick allowing the sections to telescope. In the case of the 3/4" tubing, the OD is slightly too large, and it is not possible to insert this size into the 1" material more than about a foot without getting it seriously stuck. This works fine as a fixed length spreader, but you can not vary the length. I shall focus on the construction of light weight antennas using only the 1/8", 1/4" and 1/2" sizes for the spreaders and the 3/4" and 1" sizes for boom and upper mast sections. These materials are sufficiently light that all antennas I have considered here can be easily constructed and erected by a single person.

The standard procedure used to assemble telescoping aluminum sections works equally well here. Six inches to one foot of overlap is always desired between sections. The sections are locked in place by using standard hose clamps to compress the tubing at the tip. For this to work, a slit must be cut at the tip of each section to be compressed, and the depth of the cut should be about twice the diameter of the tubing. So, for 1/2" material the cut should be about 1" and the hose clamp mounted exactly flush at the tip. The cut can be made most easily using a hack saw. you should be careful not to breath the dust from this operation, i.e., I suggest you use one of the paper filter masks while doing the sawing. You may find it difficult to find hose clamps smaller than 1/2" in most hardware stores, however, the 1/2" size will normally compress down to 1/4" but that is about the limit. The 1/8" solid rod can be used for micro extensions to the spreaders, but these are normally limited to about 6" in length. As a result, the maximum length of the spreader is limited to about 16' when using 8' sections of 1/4" and 1/2" materials. So the largest practical structure might support a full-size rotatable 20 meter dipole. A more useful limit for quads and planar wire beams is about 12'.

Supporting Spreaders

After considering many standard procedures for supporting spreaders, I decided that quick assembly was more important than cheap. There are several inexpensive ways to mount spreaders, for example, you can use a 1 or 2' section of 3/4" fiberglass rod in the center that can be U-bolted to a plate or hub. The plates and hubs are normally made of aluminum or hardwood. I experimented with both materials and found that neither suited me for this application. After discussing the problem with a good machinist, he suggested that we try PVC. We initially constructed four hubs from this material for testing, and found that it is sufficiently strong, light in weight, dark in color, easy to machine, and holds tolerances well. Currently, we are making these available in one size only, that is, for 1/2" spreaders with a 1" boom or mast. Stainless steel set screws are used to lock the spreaders into the sockets and to lock the hub to the mast or boom. The initial hubs have been in use for two nearly years at this point and show no degradation of the material other than a slight change in color. See our [Products Page](#) for details and cost. These hubs permit rapid assembly and disassembly using a small Allen wrench. We have paid considerable attention to the accuracy of the machining. The spreaders

are held accurately at ninety degrees and the length from the center of the hub to the tip is exactly one inch longer than the spreader when the spreaders are fully inserted in the sockets. These tolerances are important to maintain so that the lengths of the guy lines can be accurately calculated when they are needed.

Guy Lines

We have experimented with and tested guy lines made of three materials at this point. The decision of which to use depends upon a number of considerations such as visual impact, the amount of stretch that can be tolerated, the degradation over time related to weather and ultraviolet, and the expense of the material. The following materials have been tested:

| Material | Diameter | #Test | E, Modulus of Elasticity |
|----------------------------|--------------------|-------|--------------------------|
| Nylon Fishing Line | 25/1000" | 40 | |
| Black Dacron Rope, DR33225 | 3/32", ~ 105/1000" | >600 | |
| Bonded Kevlar, Size 207 | 25/1000" | > | |

Table 1
Properties of Guy Line Materials

Of the three materials, the Black Dacron is most visible due to its greater diameter, the Kevlar is next due to its gold color, and the Nylon is least visible of the three if the material is clear or lightly tinted. Of the three materials, the Kevlar stretches the least for a given force and does not creep with time. In general, it is difficult to measure the tensile strength of these materials, as it depends upon how the materials are tied or bonded to the supports. These materials will always break at knots, so, that tells you that tying knots in the material is not the best way to form the tie-loops. After considerable testing we found that crimp fittings designed for fishing leaders worked well for the monofilament Nylon lines. These work less well for the multi-filament line, because the line flattens easily and requires the crimp to compress fully which is often doesn't. This results in slippage under tension. In the case of Kevlar, we found that most of the failures could be prevented by double crimping and tying a double half-hitch behind the crimp. The the larger diameter Dacron material can be handled with standard aluminum crimp fittings designed for wire cable. Again, the crimp fittings have to be compressed evenly across the tube. It is a good idea to do a few practice crimps and test them under tension just to be sure you have the technique under control. Once you are sure of this, it is time to make some

guy lines of specific length.

The easiest way to make guy lines of accurate length is to fabricate them on a wood board about 8' feet long using two finishing nails separated by the desired length if the lengths are less than 8'. Longer spans can be looped back one or more times, i.e., the nails are spaced at some sub-multiple of the required length. We have found that stainless steel leader clips are very useful for attaching guys to the eye-bolts. The leader clips permit easy assembly and disassembly-assembly of the structures and provide a simple method of attachment that is stronger than most other methods. The combination of the crimp fittings and the leader clips permits the guys to be assembled under tension. As shown in the figure below. The second figure shows

The computation of the length of guy lines is normally not very difficult in the case that the assembly consisting of a hub and spreaders is planar. However, even in that case, one must make allowance for the distance of the attachment points from the spreaders, guy posts, and any other attachment structure that changes the distance between the two points of attachment. If you use snap clips, you must include them in the length of the guy. As an example, consider calculating the length of a guy line that spans the distance from a central guy post to a point near the tip of an 8' spreader. The lines are to be secured with snap clips to eye-bolts that extend perpendicular to the center post and to the spreader. Suppose the guys are attached to the center post at a height of 36" above the plane of the antenna. The eye-bolt extends 1.5" from the center of the post. The attachment to the spreader is set at 93 inches from the center of the hub, and the eye-bolts extend 1.25" above the center of the spreader. The spreaders are to be planar (not bent). The offsets due to the eye-bolts define a slightly smaller right triangle whose length, L, and height, H, are as follows:

$$L = 93 - 1.50 \text{ inches}$$

$$H = 36 - 1.25 \text{ inches}$$

So, if S is the required length of the guy line, the required length is:

$$S = \text{sqrt}(L^2 + H^2) = 97.9"$$

In the case where the spreaders are bent out of the plane, the computation of the guy lengths is a little more complicated. This is because as the spreader is bent by pulling on the guy point near the tip, the length of the guy point moves up and out of the plane and closer to the center guy pole. If you choose the amount to bend upward out of the plane, you then must know how far that point moves toward the center as well as the angle of the bend at the guy point on the spreader. Calculating these quantities is possible but a bit complicated, so it may be simpler

just to bend the spreader and measure the length from the guy point to a point perpendicular to the guy pole or directly to the attachment point on the guy pole. However, the table below gives the approximate length of the tip of the spreader perpendicular to the center of the guy pole, the elevation of the tip above the plane of the hub, and the approximate force required to pull the spreader into this shape when guyed to a 3' guy pole.

All materials used for guy lines stretch, and the amount of tension in the line determines how much it stretches. Different materials of various weights stretch different amounts, so you may want to measure the amount of stretch. Nylon fish line stretches quite a lot while Kevlar thread hardly stretches at all. The stretched materials also grow in length under tension, for example, a Nylon line cut initially to 100" may creep to 104" when to about 3 kg or 6.6 lbs. It will also almost return to its original length when left un-tensioned. Because of this behavior, it is very difficult to measure the modulus of elasticity except by dynamic means. On the other hand, a similar length of Kevlar thread size #207 will stretch only about 3/8" when tensioned to 3kg and returns to the same length when the tension is removed. However, even the Kevlar deforms slightly over a period of weeks by about 3/8" to 1/2" for a 100" length. This means that you should provide for some room for adjustment when setting the locations of the guy points. You should assume that line lengths will grow a bit and provide space to extend the guy points. It is also possible to alleviate the stretching by pre-tensioning the material before cutting the lengths, and this is especially true for Nylon. In the case of Kevlar, the tension may take several days to weeks to stretch the material. Pre-tensioning also is commonly done with copper antenna wire, as it also grows in length in a similar manner. So, it is a good idea to pre-tension all materials before cutting. The only exception to this rule might be the Kevlar.

Fortunately, it is easy to compute the amount of stretch for a given material with simple tools. If you have a fishing scale, a pulley, a long board and a few nails, you have every thing you need. Or you can use the same materials that we use for which the numbers are known. (to be completed)

[Return to Main Menu](#)

VISIT SOME OF MY OTHER WEBSITES BY CLICKING ON EACH TITLE:

["HAM RADIO AMONG THE ALLIGATORS"](#)

["THE WORLD TRADE CENTER DISASTER"](#)

["EMERGENCY COMMUNICATIONS-WHAT TO BRING AND WHY"](#)

["HAM RADIO'S HEALTH HAZARDS"](#)

["FAMILY PREPAREDNESS"-NEW !](#)



W2IK Presents:
**"OVERLOOKED ANTENNA
 CONSTRUCTION TIPS"**

=====

By Bob Hejl - W2IK c2004

Many ham radio operators enjoy the triumph of constructing or repairing their own antennas. As guidelines, they often use one or more of the many antenna designs which are available in both books and on the Internet. Sometimes they might even take a basic design and adapt it to increase it's efficiency or to make the antenna fit within the physical limitations of their property. It is unfortunate that in these designs little thought is ever given regarding material selection beyond it's cost, weight and strength. There is another important detail that must be taken into consideration during selection and before construction is to begin. The best antenna design using the strongest materials available may be a fruitless effort if you expect your antenna to perform for an extended period of time. One of the most overlooked antenna construction considerations involves the action that usually occurs when two dissimilar metals are brought into physical contact (mated) during the assembly process and exposed to the weather. There can be a serious onset of a type of corrosion at their respective contact points.

This corrosion, also called "galvanic corrosion", can create havoc in as little as three months. Galvanic corrosion is a process that occurs when certain metals are connected to each other and moisture, such as rain, condensation or even high humidity, is introduced. When all of this is present, electrons flow between the two metals (also called "ionic flow"), which causes the most chemically active metal to change. When galvanic corrosion occurs, it can usually be identified by characteristic surface blistering or white powder corrosion around dissimilar metal points.

If left on its own, the corrosion process will continue, eventually pitting of the metal will occur and electrical or RF conductivity will fail. It's problems can be magnified when an antenna is used in humid, windy, intense heat or cold (thermo-galvanic corrosion) or other harsh conditions. Even an antenna encased in a fiberglass shell, such as a vhf or uhf repeater antenna, can suffer from the effects of this corrosion.

There is a direct relationship between various types of dissimilar metals when they are mated. Some dissimilar metals, such as copper and brass, when mated cause very little corrosion. There are other metals, however, that react most harshly when matched. Zinc and brass, for example, will cause corrosion with the zinc metal quickly breaking down. If you wish to prevent galvanic corrosion the best means, of course, is to use the same metal throughout your construction. If this is not possible your next course of action would be to assemble materials that have a close relationship on a galvanic metals table. Here is a descending list of metals and their associated relationships in order of the most "noble" or least active.

least active

gold

silver

silver solder

bronze

copper

brass

nickel (plating)

tin
lead
lead-tin solder
stainless steel
iron/steel
aluminum alloys
aluminum
zinc-galvanized steel
most active
zinc

When choosing materials you should try to pick a metal part made from the type closest to the other metal parts you will be using as charted on the above list. It is very important to consider EVERY part of your antenna including clamps and washers. For example, if brass screws are used to hold aluminum tubing in place they will cause a headache when corrosion takes hold. The better choices would be either stainless-steel screws to secure aluminum tubing or brass screws to hold copper tubing.

Remember that if you are refurbishing an antenna system you might be locked into using a hard to find piece of hardware based upon the original construction materials. Some antenna companies skim by using the cheapest, but improper mating metals. For example, if you are servicing a tall two-meter base or repeater antenna and you notice that the antenna company used stainless steel couplers and set screws to link two sections of brass or copper rods it would be wise to replace the couplers and the set screws with brass components. If you don't, you might find that the antenna will exhibit intermittent high swr when unseen corrosion takes place between the set screws and the rods. If any wind flexes the antenna the flexing will cause the corrosive joint to change the swr and it will not only effect your signal but will also stress your transmitter as the load it sees will constantly change with the wind. You don't want to "lose" a set of repeater output transistors because of antenna joint corrosion that could have been prevented. It's worth the extra time to locate hardware made of either the same metal or one closest to the antenna metal as outlined on my chart. In doing so you will avoid having to re-fix the problems caused by improper repair.

If you need to clean off a metal surface it is important to use a "like metal" brush to do so. Using steel wool to clean a brass rod that might be part of a vhf/uhf repeater antenna will embed small particles of steel into the rod and create a corrosive atmosphere. Use a small brass brush instead. Be aware that even when you solder, the type of solder used (silver solder or tin-lead solder) needs to be considered based upon what you are bonding. When you construct an antenna also be aware that the surface area of each contact point is very important. Making one small point of contact, using one set-screw for example, will increase the possibility of galvanic corrosion creating problems. This is compounded by the fact that any RF energy will have to pass through a smaller contact point causing additional resistance. If you must assemble two pieces of your antenna either design a larger overlap or use two or MORE flat tipped set-screws to hold the joint. Do not use plated set-screws because as soon as they are tightened they will lose some of their plating at the contact point possibly exposing the metal below the plating. This may cause a corrosion problem unseen to the naked eye. Multiple set-screws within the same collar are a must. This not only reduces the problem but also makes a better physical connection that won't be as easily loosened due to winds or vibrations.

Whenever you are inspecting an antenna for refurbishing, the tiny corrosion on the contact point of a set-screw may go un-noticed. Many problems can arise due to galvanic corrosion including high swr, lowered output power, reduced receive capability, introduction of intermod in vhf and uhf operations, induced static in receive, an increase in "stray current corrosion", "telluric effect corrosion" and harmonic interference being generated. If you find it necessary to combine metals not closely linked on the above list, use an intermediate metal, such as if you must attach a copper wire to aluminum tubing, use stainless steel or nickel washers and a stainless steel screw or a tinned solder lug with a stainless steel screw. This isn't the best solution, but it will reduce the chance of corrosion. The best answer is to always use "like metals" where possible.

In every case of bonding or connection, in order to reduce the galvanic corrosion, coat all of your antenna's joints and connections. This can be done with a joint sealing compound, but it is important that the compound is non-hygroscopic (not waterbased) and does not contain any aggressive ions that can be leached during service. Spray or paint on coatings that contain zinc or aluminum powder should be avoided. Epoxy-based coatings are much better. If possible, use a clear type as this will aid in joint inspections. If, during any inspection, you see a peeling of the sealer, remove it completely and re-apply. These epoxy coatings can be obtained at most marine supply companies as they are made for both marine and atmospheric applications. Make sure that the surface you wish to protect (the joint) is clean and dry. The spray type allows you a quick seal coating "in the field". In humid conditions, use a hair dryer to remove any moisture. You do NOT want any moisture trapped under the coating. If you are working with tubing, remember that moisture can be introduced through the ends of the tubing into the interior of the joint so make sure the tubing ends are also sealed. The less moisture the better the joint will be protected. BEFORE YOU COAT: Make sure that no corrosion has taken place at the joint. If it has, the corrosion that has started will continue. Take the time... inspect, clean and re-assemble any questionable joint. Also be aware that even when bolting your antenna to a tower you need to use the right hardware. Refrain from using stainless steel "U" bolts to connect an antenna to

an aluminum tower even though the two metals are close on the list. Use aluminum hardware or galvanized "U" bolts. So the next time you plan on building or repairing that antenna, consider your material selections accordingly.

BEFORE YOU LEAVE:

While I have your ear there is something else you should also know. This same principle also should be applied when repairing or installing a grounding system for your shack. Don't use copper grounding braid and attach it to steel (or even copper-clad steel) ground rods!! This creates a wonderful corrosion point that not only affects your system from a safety standpoint, but also RF may be reintroduced back into your shack and give you a nasty RF burn. Ouch ! Your best bet: Use several 1/2 inch copper tubing sections to act as ground rods, then attach your copper ground wire or braid using copper or brass clamps or wrap it around the tubing and solder it using silver solder. Another reason for doing this is that the copper tubing has more surface area exposure to the ground and is, of course, a better conductor. Use more than one and stagger them so they are not in a straight line and space them differently and not a fractional wavelength such as 1/4 wavelength from each other.

page created with [Easy Designer](#)

The Antenna Elmer

Here you will find information about wire antennas as well as directional beams.



[HF / VHF / UHF dipoles](#)

[Other wire antennas](#)

[Design your own dipoles and inverted vees \(Metric\)](#)

[Design your own ground plane \(Metric\)](#)

[Design your own 5/8 wave vertical antenna](#)

[Design your own quad \(Metric\)](#)

[Folded dipoles](#)

[Design your own dipoles and inverted vees](#)

[Design your own ground plane](#)

[Design your own half wave vertical antenna](#)

[Design your own quad](#)

[2 meter 2 element direct connect beam](#)

[HF satellite antenna \(10/15 meter beam\)](#)

[2 meter 3 element direct connect beam](#)

[VHF / UHF direct connect beams](#)

[Fan-tenna...An antenna made from a fan?](#)

[Calculate electrical length of a line](#)

[Determine the power output to your antenna](#)

[How long should my coax cable be?](#)

[Convert from feet to meters](#)

[Quarter wave line matching transformer](#)

[Decimal to fraction conversion chart](#)

[Determine the efficiency of your transmission line](#)

[Frequency scaling](#)

[Convert from meters to feet](#)

[Antenna construction tips](#)

[Back to the Home Page](#)

All trademarks mentioned belong to their respective owners.

The content on this page is provided as is, and should be accepted and used without expecting any particular fitness for any particular purpose. No liability is assumed with respect to the use of this information.

© Copyright 1996 — 97 Edward Oros and Bob Cocco

Formulas To Design Your Own Dipoles And Inverted Vees

Most hams are familiar with the center fed, half wave dipoles and inverted vees that are very popular and easy to build.

This formula will give you a starting point to make these antennas. There are several factors that affect the resonant frequency of any antenna. Some of these factors are: the height above ground, the diameter of the wire, nearby structures, the affects of other antennas in the area and even the conductivity of the soil.

If you've ever used some of the other antenna design programs you may realize that the formula for these types of antennas vary from about $476/f$ Mhz to $490/f$ MHz depending on the band and the height above ground!

Fortunately there is a **standard** formula that can be used as a starting point in your design. For a center fed, wire dipole, this formula is $468 / \text{frequency in megahertz}$. I've always cut the antenna a few inches longer which would allow me to trim the antenna in order to obtain a 1:1 match.

The inverted vee has always been about 3 - 5% shorter than a dipole at the same frequency. I used 4% as a constant in the calculation. You may change this value to any number that you like to use.

This page uses the standard formula, $468 / f$ MHz to calculate dipole lengths. You may change this number if you know of a better number to use as your starting point.

Enter the formula for the antenna calculation

Divided by Freq MHz

Percent smaller for the Inverted Vee

Your dipole's total length is feet

Each leg of the dipole is feet

Your Inverted Vee's total length is feet

Each leg of the Inverted Vee is feet

[Return to Main Page](#)

AMANDX PRESENTS



DIPOLE ANTENNA



INTRODUCTION-The longwire antenna is a very effective antenna for the listener who wants to cover all of the shortwave bands from 530 KHZ to 30 MHZ. However if you have some favourite frequencies that you listen to on a regular basis you may wish to consider a dipole antenna. This antenna is a fairly easy to construct antenna and will give you better reception on the frequency it is cut for. Think of a dipole as a longwire that has a insulator in the middle.

FREQUENCY-A dipole antenna will not only work well on the frequency it is cut for, but also for the multiples of that frequency. For example if you cut a dipole for 7.0 Mhz will also work well on 14 Mhz, 21 Mhz and 28 Mhz. This way if you can pick and choose your frequency you can make one antenna work on two or three bands.

LENGTH- To find out how long the antenna should be all you have to do is fill in a simple formula:

FREQUENCY IN MHZ divide by 468 = LENGTH IN FEET

That is the only formula you need ever know to build a dipole antenna.

Formulas To Design Your Own Dipoles And Inverted Vees

This page uses the standard formula, $468 / f$ MHz to calculate dipole lengths. You may change this number if you know of a better number to use as your starting point.

Enter the formula for the antenna calculation

Divided by Freq MHz

Percent smaller for the Inverted Vee

Your dipole's total length is feet

Each leg of the dipole is feet

Your Inverted Vee's total length is feet

Each leg of the Inverted Vee is feet

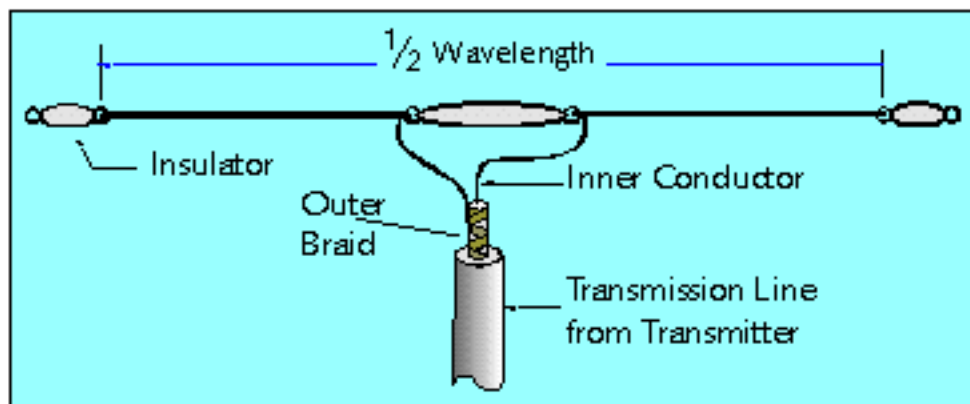

dipole antenna

CONSTRUCTION- Once you have selected a frequency and calculated the length of wire you need add two feet to this length. This is done so you will have six (6) inches of wire at each end to wrap around the insulators. Once you have this extended length of wire cut it in half. This will give you both sides of the dipole.

Attach an end insulator to one end of each piece of wire. You can use the egg shaped insulators sold by many radio supply stores or make your own out of a piece of plastic. This can be done by cutting a piece of heavy plastic or plexi-glass to a size of about six (6) inches in length and about 2-3 inches wide. Drill a small hole one to one and a half inches from each end of the plastic to wrap the wire around. It is best to solder these connections and wrap them in a sealant tape to keep the effects of the weather from harming them.

The other free ends are attached to a centre connector which you can buy with a built in coaxial cable connector, or make your own. This will look similar to the end connectors but you will have to find a way to secure the coax lead wire to the insulator. If you build your own when you attach the coax to the ends of the wires, insure that you solder and wrap the connections. One wire will go to the centre of the coax, while the other wire will go to the shielded braid of the coax. This will give you a perfect half wave dipole. You should also wrap the coax fitting of the commercially available centre insulator to keep water and other moisture out. Moisture will ruin the connections on any type of insulator and make the antenna less effective or at worst useless.

MULTI-BAND DIPOLES- As was stated above you can use the dipole on the harmonics or multiples of the frequency it is cut for. However if you are short on space you can build a multi-band dipole. This way you will get an antenna that will operate on several frequencies. Instead of using a single strand of wire you can use wire that has several insulated wires in it. These **MUST** be insulated wires to insure that they do not touch each other. You then cut the top wire to be the longest, the second wire to be the second longest, the third wire to be the third longest etc.. Only the longest wire is attached to the end insulators and all wires are fed to the centre insulator to attach to the coax feed line.

INSTALLATION- Once you have the antenna cut all you have to do is put it between two masts. Make sure that you use the free side of the end insulators to attach some rope. Tie this rope from the end insulators to the masts. Leave some slack on the antenna. If you pull too tight the antenna will break in the wind or if snow and or ice should coat the antenna. **KEEP AWAY FROM OVERHEAD WIRES!!** Keep away from these as should the antenna ever come into contact with an overhead wire you will do permanent damage to your radio if not yourself. All you have to do is feed the coax to your radio and listen to the stations come in. It would be best to install a lightning arrester in the coax feed line to help protect your receiver. These are available from many radio supply stores. Follow the instructions carefully! In areas where thunder storms or snow storms are common a lightning arrester is a must for safety.

You can install them flat or at an angle. If at an angle they will be more directional the direction taht they are sloped. You can also istall them as an inverted V shape. This dipole has a higher center with lower ends to save on space in smaller back yards. All three versions work well.

FURTHER INFORMATION- If you want more information on dipole antennas and for that matter all types of shortwave antennas look for these books:

Easy-up Antennas for Radio Listeners and Hams by Edward M. Noll

Joe Carr's Receiving Antenna Handbook by Joe Carr

The Easy Wire Antenna Handbook by Dave Ingram

Practical Wire Antennas by J. Heys

These books are orientated towards the Shortwave Listener more so than the Ham operator. The first two above are probably the best for the beginner and the more advanced, but not technically minded. They put forward a lot of information in a manner everyone can understand. Ed Noll's Easy-up Antennas for Radio Listeners and Hams even comes with tables giving you pre-calculated lengths for many types of antennas. There is lots of tips on making antenna construction simple but effective. It does not come any easier than this.

[RETURN TO MAIN PAGE](#)

Remember On A Clear Day You Can Hear Forever

This page will work best with Netscape

Antenna Calculations

This will calculate the length of a 1 wavelength loop

| Freq. in Megahertz | length of loop in feet | | |
|----------------------|------------------------|----------------------|----------------------|
| <input type="text"/> | <input type="text"/> | <input type="text"/> | <input type="text"/> |

This will calculate the length of a half wave dipole.

| Freq. in Megahertz | length of half wave length wire in feet | | |
|----------------------|---|----------------------|----------------------|
| <input type="text"/> | <input type="text"/> | <input type="text"/> | <input type="text"/> |

This will calculate the length of a 5/8 wave vertical with 1/4 wave radials.

| Freq. in Megahertz | length of 5/8 wave vertical in feet | length of 1/4 wave radials in feet | | |
|----------------------|-------------------------------------|------------------------------------|----------------------|----------------------|
| <input type="text"/> | <input type="text"/> | <input type="text"/> | <input type="text"/> | <input type="text"/> |

| Freq. in Megahertz | length of L1 in feet | length of L2 and L3 in feet | | |
|----------------------|----------------------|-----------------------------|----------------------|----------------------|
| <input type="text"/> | <input type="text"/> | <input type="text"/> | <input type="text"/> | <input type="text"/> |

[HOME](#)

This page hosted by

Get your own [Free Home Page](#)



Why I use dBi---Mostly

L. B. Cebik, W4RNL



Although current commercial practice is to specify antenna gain in dBd, I tend in my modeling work to use dBi. It is reasonable to ask why, if for no other reason than to understand better the other entries in this collection of notes. So I shall explain why. My object is not to get anyone to change their preferred ways, but only to make a little clearer my preference for specifying gain in dBi.

dBi

Every measure in decibels, or dB, is ultimately a relative power measurement (with some defined relative voltage and current measures having been derived from the basic power measure). Decibels are defined this way:

$$\text{Relative power in dB} = 10 \log (\text{base } 10) P1 / P2,$$

where P1 and P2 are two power levels measured in the same units (e.g., watts).

Since we may pick any two powers for P1 and P2, power gain or loss is strictly relative.

However, we have found it useful to select--for specific purposes--certain baseline power levels. One such level is whatever power there might be in the radiation far field of an isotropic radiator. An isotropic radiator is a lossless dimensionless point in free space that radiates equally well in all directions. Although some say this is an absolutely theoretic concept only, Brian Beezley, K6STI, has established that a pretty good approximation of an isotropic radiator can actually be constructed.

Using this radiator as the baseline and taking measurements at the same far field distance from the antenna, the power received from the antenna will have a certain relative level in comparison to what would have been received from the isotropic radiator. What that level is depends on the characteristics of the test antenna and the direction in which we choose to take the readings, using a full 3-dimensional sphere as the possible directions for readings. In some directions we may get more power; in others we may receive less.

One of the chief advantages of the isotropic radiator is that its field never changes, so that it functions as

an agreed upon constant against which every antenna may be measured in every direction.

Every antenna measurement referenced to a P2 that is the far field power from an isotropic radiator has a positive or negative gain in dBi.

Gain

When we casually refer to antenna gain, we do not normally mean the gain in any haphazard direction from the test antenna. Nor do we mean all the possible gain numbers we might gather from a systematic tour around the surface of our far field globe surrounding the antenna. Gain in every direction is important, for it defines the antenna pattern and tells us where the far field is strongest and weakest and in the middle--and by how much.

However, when we casually mention gain, we are usually interested in the direction(s) of maximum gain from a given test antenna. Then we rotate the antenna to present that antenna direction to the receiving station. For satellites, we may rotate in 3 dimensions, but for HF, 2-dimensional rotation usually suffices (unless we must somehow compensate for a bit of tricky terrain and have the wherewithal to do so).

We can specify maximum antenna gain in terms of dBi. Then we can compare maximum antenna gains from 2 or more antennas by citing their gains in dBi and merely comparing numbers.

This practice is perfectly reasonable so long as we do not make it a fetish; that is, so long as we do not use this number exclusively in our gain considerations. Horizontal beamwidth is also important and is usually defined in terms of the number of degrees between half-power or -3 dB points where the direction of maximum gain is the center. Vertical beamwidth is also important in estimating the success of a potential path. We also want to know, in conjunction with vertical beamwidth, the elevation angle of maximum radiation. Together, these numbers give a more complete picture of antenna performance in a desired direction than raw gain alone.

I have modeled an array with a 21 dBi gain figure. However, the horizontal beamwidth is only about 17 or 18 degrees wide, making it unsuited for general amateur operation. However, we often assume that competing antennas have the same beamwidth and that all we need to know in making our selection is the maximum gain. Good practice calls for making no such assumption. Rather, before we focus on maximum gain, we should establish that all other factors are equal.

dBd: a warm but fuzzy concept

The concept of dBd was formed to capture the gain of an antenna relative to a dipole. A dipole is considered the standard basic horizontal antenna, and comparisons to it seemed to some folks to be more meaningful than comparisons to the isotropic radiator.

Unfortunately, the concept of dBd has become a cluster of concepts. Here are some of them. The notation is my own, since few folks are anxious to distinguish the individuals in the cluster.

1. dBd-I: dBd ideal compares the gain of an antenna to an ideal dipole in free space. An ideal dipole uses infinitely thin lossless wire and is resonant at the frequency of interest. In this application, the ideal dipole has a gain of about 2.15 dBi, that is, 2.15 dB over an isotropic radiator. All measurements are thus arithmetically transportable between dBi and dBd-I by adding or subtracting 2.15, as appropriate.

dBd-I is of limited utility, since my backyard dipole may have a gain of 7.15 dBi and 5 dBd. Some folks become confused by the idea that a dipole has gain over a dipole. We then have to explain that the real wire dipole has gain over the perfect dipole in free space. That rarely helps a lot. And it does not tell us until we do some arithmetic how much gain some other antenna has over a real dipole.

2. dBd-RM: dBd can be expressed as the gain over a real dipole modeled at the same height as the test antenna. For studies that are strictly modeling investigations, this measure is sometimes useful. However, it requires that we further specify the construction of the dipole in terms of element diameter and element material. Using the same material, dipole gain will vary with element diameter. It will also vary inversely with the loss of the material used for the dipole.

Both these constraints apply within the further rule of keeping the dipole resonant. If we make measurements across a ham band, we shall find that the dipole gain varies with frequency unless we reresonate it for each readout frequency. Actually, we are usually more careless than this and take one resonant reading and apply it across the band without checking. And we tend to use fairly loose standards of resonance rather than converging the results. We may more precisely say that an antenna is resonant when the reduction of feedpoint reactance results in no further changes in gain to the number of significant digits that apply to the test.

As one more qualification, we should note that dipoles and other antennas may have different elevation angles of maximum radiation over the same type of ground. When we cite dBd-RM, we must also say whether we are giving the figure for the dipole at its angle of maximum radiation or at the angle chosen for the test antenna. To avoid confusion, it is usually better to give details about the differing elevation patterns.

3. dBd-RR: dBd can be expressed as the gain over a real dipole set in the same position as the test antenna, where both antennas are oriented for maximum gain relative to the far field receiving site of the test range. For fairness, one should specify the construction of the dipole to ensure that the materials are comparable to those of the test antenna.

However, there are a number of variables that occur within this way of handling dBd. First, range conditions vary considerably from one site to another. Second, some testers take the average of a number of readings in various directions, while others take readings along a single line defined as the best test line. Third, different ranges may use different test heights. The importance of this factor stems from the

fact that many antennas that might be tested have different elevation angles of maximum radiation than a dipole, and this variance may introduce differences in readings as we change test antennas and as we move from range to range with different test antenna heights.

Good testing and modeling protocols would specify all of the relevant factors applying to the comparisons involved. We sometimes do find these specifications. Unfortunately, we often don't. Without the specifications, comparisons in dBd-R (either M or R) are quite difficult to make. If we could only bring all antennas to a single test range with a single (large) set of dipoles and standardized conditions, we could likely establish the gain of each antenna over its standard dipole and then have truly precise comparisons among antennas. Someone has noted to me that the odds of the earth being struck by a meteor like the one which ended the reign of the dinosaurs are higher than the odds of the emergence of a universal test range. I really wish I could have disagreed with this individual.

For additional [pitfalls of careless dBd-ing](#), see the next item on the Index.

Why I tend to stick to dBi

My antenna work includes the building of test models of antennas that are feasible to construct, but is devoted predominantly to modeling all sorts of antennas for all sorts of purposes. This factor alone suggests the use of a single standard for all comparisons, such as dBi. However, there are a number of reasons I tend not to use dBd except in special circumstances.

1. The relevant comparisons are not with a dipole. Very often, antenna comparisons are among antennas that do not include dipoles. In such cases, simply comparing gain figures in dBi tells us all we need to know and can know about the relative maximum gains of the antennas. For example, in comparing the gains of self-contained 1 wl wire-loop antennas, the best designs for a given purpose are the ones that are best within the group, and the group does not include a horizontal dipole.

Likewise, when contemplating whether it is worthwhile to increase the size of a Yagi for 20 meters from 3 to 4 elements, the dipole is not relevant. Rather, the relevant gain comparison is between both models and real antennas of 3 and 4 element design. The gain advantage is derived as easily from dBi as from any other system of gain numbers.

2. The relevant comparisons have only passing reference to maximum gain. Additional factors, such as elevation angle, beamwidth, etc., may be far more important than gain itself. For some applications, good antennas do not need gain relative to a dipole. But they may require close specification of other antenna properties. Gain becomes a secondary specification for which dBi suffices nicely.

Range tests are another matter

If my work were primarily with real antennas, then dBi would become a problematical term. A test range

approximation of an isotropic radiator is an unlikely event anytime soon. Hence, antennas on test ranges must be compared to some standard, and the dipole is the most likely simple horizontally polarized candidate. If we accept this premise, then it is unreasonable to expect range testers to then correlate their results to a scheme of modeling in which the gain is converted to a value in dBi.

However, this situation makes it imperative that range testers specify a test protocol and comparison antenna for the evaluation of the procedure against good engineering practice. In many instances, the comparison antenna will not be a dipole (although amateurs often think only in terms of Yagi tests). Verticals require specification of a vertical standard of the appropriate class. Nothing substitutes for the revelation of detailed test protocols where range testing is at stake.

Conversion of the test situation to models--like any other case of modeling--is at best the most reasonable approximation we can develop. Absolute precision is unlikely in most instances. Hence, the conversion of range test results to modeling results--with the accompanying conversion of dBd-RR (with a clear specification of the standard dipole used) to dBi--is not an automatic process and is subject to varying degrees of adequacy.

Modeling of detailed test protocols, on the other hand, can yield some correlation factors among different test protocols. A model may substitute one standard dipole for another, may insert or remove test range objects affecting results, may change antenna heights with ease, etc. As a simple example, if Smith tests his antenna at 60' up and Jones tests his at 85' up, the differences in test results (all other factors being equal or equalized) can be at least tentatively resolved with effective modeling.

Whatever the prospects for such work in the future (for we have just begun to scratch the surface of effective modeling in antenna work), those who predominantly model will likely stick to dBi as the basic measure of maximum gain. Range testers will likely stick to dBd-RR, where the range test is a comparison to a dipole or other relevant standard.

Since I am mostly a modeler, I use dBi---mostly.

Updated 6-23-97. © L. B. Cebik, W4RNL. Data may be used for personal purposes, but may not be reproduced for publication in print or any other medium without permission of the author.



[Return to Main Index](#)

How High should my Dipole be?

Dipole Antennas - the Effect of Height Above Ground

I frequently hear the question: how high should my dipole be? Or alternatively, will my dipole work well at this or that height? Unfortunately, these questions can not be answered without first stating what you want the dipole to actually DO, i.e. how you plan to operate with it. Some possible goals for a dipole might be:

1. DX work.
2. Local work: nets and rag chewing.
3. Directionality: gain in one direction, or nulls in some other direction
4. Omni-directionality.
5. Feed point impedance of 50 ohms.

As you may surmise, many of these potential goals are mutually exclusive, or at least tradeoffs. However, once you define what you want to do with your dipole, then you can look at the radiation patterns to see if it will accomplish those goals.

I make the assumption that anyone reading this understands that DX work requires a low angle of radiation, with gain in the favored direction being desirable. Nets and rag chewing require a much higher angle of radiation and an omni-directional pattern. A null aimed in some direction may be desirable in various situations. Something close to 50 ohms impedance will aide matching and power transfer to/from coax cable.

There are many other potential goals for a dipole, but the ones I have listed are those that are most dependent on it's height above ground. Thus this discussion will not touch upon the issues of multi - banded operation, tuned open wire feeders, and the like. So, lets limit the issue at hand to: how the character of a dipole varies with its height above ground.

To investigate this problem, I have modeled a hypothetical wire dipole using the EZNEC program (from W7EL). This model is well within the verified capability of EZNEC.

For those interested in the modeling details, this dipole, named D40M, has the following specifications:

Material: #12 copper wire.

Length: 69.057 feet.

Ground Type: good (.005,13) NEC Sommerfield.

Frequency: 7.00 MHz nominal, but the comparative patterns were computed by adjusting the frequency slightly for resonance at each height.

The dipole was modeled at various heights from .05 wavelengths (7 feet) to 4 wavelengths (560 feet) above

good ground. One may argue that 560 feet is ridiculous for a 40 meter dipole, but keep in mind that the data can be scaled down to a 10 meter dipole with similar results.

The table below tabulates the results. In the first two columns, the antenna's height above ground is given in wavelengths and in feet. The next two columns show the maximum gain in the favored direction (i.e. broadside to the wire), followed by the launch angle and the -3 dB vertical beam width. The next two columns once again present the gain and launch angle / beam width, but for the axial direction (off the ends of the wire). Finally, the last 2 columns list the complex impedance at the feed point, and the actual resonance frequency at that specific height.

| Height | Height | Fav Dir | Fav Dir | End Dir | End Dir | | |
|-------------|--------|---------|-------------------|---------|-------------------|-----------|------|
| | | | Launch | | Launch | | |
| Wave | | Gain | Angle/ Bmwidth | Gain | Angle/ Bmwidth | Feedpt | Res. |
| Lengths | Feet | (dbi) | | (dbi) | | Z | Freq |
| 4.0* | 560 | 7.75 | 4 / 4 | 5.57 | 72 / 13 | | 6.93 |
| 3.0 | 420 | 7.83 | 5 / 5 | 5.25 | 68 / 14 | 77 + j11 | 6.94 |
| 2.0* | 280 | 7.80 | 7 / 7 | 0 | 39 / | 75 + j12 | 6.95 |
| 1.5 | 210 | 7.72 | 9 / 10 | -2.50 | 33 / | 75 + j11 | 6.96 |
| 1.0* | 140 | 7.64 | 14 / 15 | -11.00 | 20 / | 74 + j08 | 6.96 |
| .9 | 126 | 7.03 | 16 / 17 | -8.30 | 22 / | 85 + j13 | 6.94 |
| .8 | 112 | 7.16 | 18 / 19 | -6.40 | 25 / | 84 + j26 | 6.88 |
| .7* | 98 | 7.95 | 20 / 22 | -4.50 | 30 / | 70 + j30 | 6.88 |
| .6 | 84 | 8.35 | 23 / 26 | -1.95 | 40 / | 60 + j16 | 6.94 |
| .5* | 70 | 7.45 | 28 / 33 | -0.51 | 43 / 33 | 71 - j00 | 7.00 |
| .4 | 56 | 6.06 | 35 / 47 | 1.30 | 59 / 102 | 93 + j04 | 6.98 |
| .3* | 42 | 5.59 | 50 / 137 | 4.71 | 90 / 80 | 100 + j32 | 6.86 |
| .2 | 28 | 6.70 | 90 / 118 | 6.70 | 90 / 67 | 71 + j56 | 6.77 |
| .1* | 14 | 8.21 | 90 / 103 | 8.21 | 90 / 66 | 23 + j39 | 6.84 |
| .05 | 7 | 9.61 | 90 / 99 | 9.60 | 90 / 72 | 7 + j12 | 6.95 |

* Elevation plots shown below

Analysis, Favored Direction:

The first thing to notice is that the gain in the favored (broadside) direction varies very little with height. The important change in the broadside pattern occurs in the launch angle of the primary lobe. As the antenna

moves closer to the ground, the launch angle of radiation gets higher and the -3 dB vertical beam width becomes broader. Note that below the benchmark height of $\frac{1}{2}$ wavelength, the launch angle increases rapidly. Once the dipole is lowered to 0.3 wavelengths, most of the radiation goes in a vertical direction. This explains the frequently heard "rule" that a dipole must be at least $\frac{1}{2}$ wavelength high to work. The seeming anomaly with the beam width below 0.4 wavelengths is easier to understand by viewing the plots shown below.

Analysis, End-Fire Direction:

One frequently sees a dipole azimuth pattern depicting a very sharp null off of the ends of a dipole. While technically accurate, this can be very misleading as the table above shows, and is a result of trying to depict a 3 dimensional pattern in 2 dimensions. This often seen null is only evident at the same launch angle as the maximum broadside gain. Of major significance is the large amount of gain off the ends at higher launch angles. Due to multiple lobes forming above $\frac{1}{2}$ wavelength, this is not easily shown in tabular form. I have arbitrarily chosen to list gain and launch angle for the secondary lobe with the lowest launch angle, but recognize that there is frequently a stronger primary lobe at higher angles. Consult the plots below for a better visualization.

Analysis, Feed Point Impedance:

The reference antenna length was chosen to resonate at the $\frac{1}{2}$ wavelength height. As expected, the feed point impedance oscillates significantly as the height changes from our reference point. Thus we verify the old adage that you must trim the dipole to fit your particular QTH (height being very important). The corresponding resonant frequency for each height is shown in the last column for reference, since complex impedance's may be of less practical importance to some.

So, How High should the dipole be to work well?

Now we are back to looking at what we want the dipole to achieve.

For DX work, higher placement is warranted, since more power concentrated between 5 and 15 degrees is reported to be of major benefit. Heights around one wavelength are necessary to get the broadside lobe to launch in this range. However, higher may not always be better. Pay careful attention to the magnitude of secondary lobes in the broadside direction, as well as high angle radiation off the ends. Some heights would appear better than others due to concerns with nulling out local QRM. A complete discussion of of this aspect is beyond the scope of this article, but may be investigated at a later date.

For local work, lower heights appear to be more beneficial. Note especially how omni-directional our dipole becomes at lower heights. Below 0.4 wavelengths, there is less than 1 dB of attenuation in the end fire direction, which suggests a height between 0.4 and 0.3 might be an ideal compromise for local nets and rag chewing.

Feed point impedance and matching does not seem to be of major concern except at very low heights. The effect of height on 2:1 SWR bandwidth was not investigated.

Radiation Plots

Our first plot shows the elevation pattern in both the broadside (white trace) and end fire (yellow trace) directions for a height of 4 wavelengths, or 560 feet. Note the substantial high angle radiation in all directions, in addition to the excellent low angle lobes.

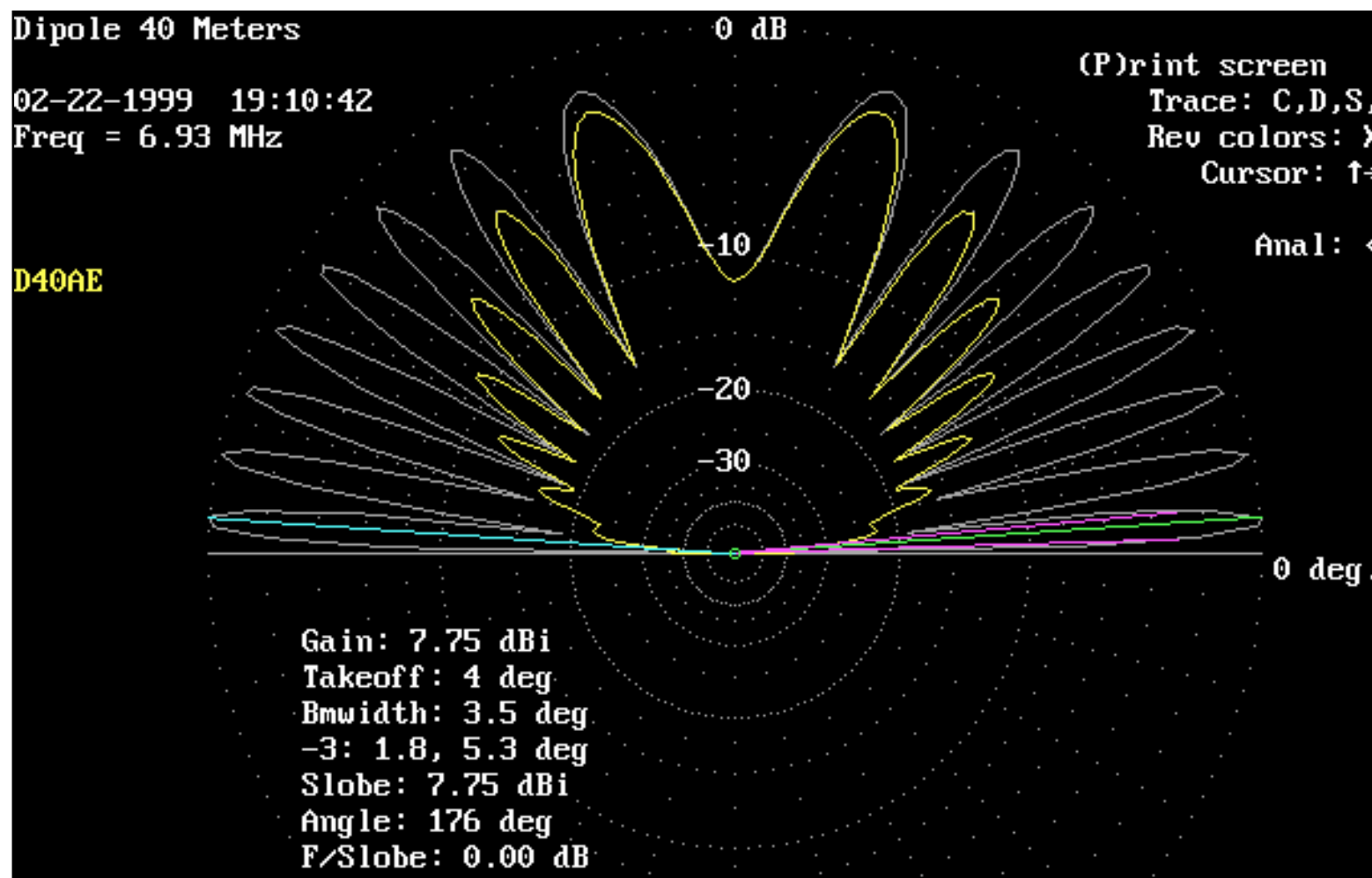

This plot shows the elevation patterns at a height of 2 wavelengths, or 280 feet. White trace is broadside. Yellow trace is axial (off the ends). Still Lots of high angle radiation.

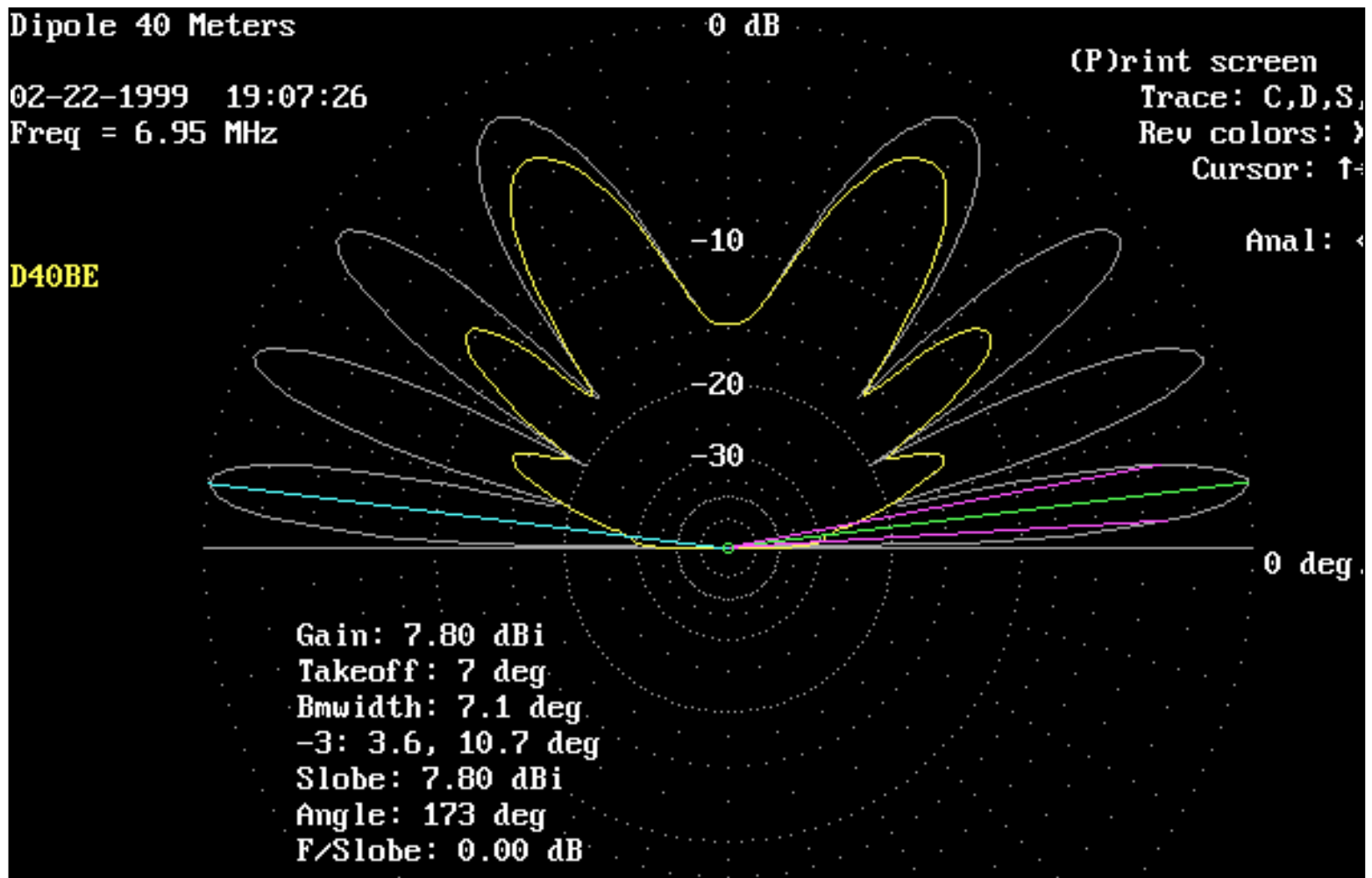

This plot shows the elevation patterns at a height of 1 wavelength, or 140 feet.
 White trace is broadside. Yellow trace is axial (off the ends).
 The secondary lobe is down to 47 degrees, but the primary lobe is up to 14 degrees.

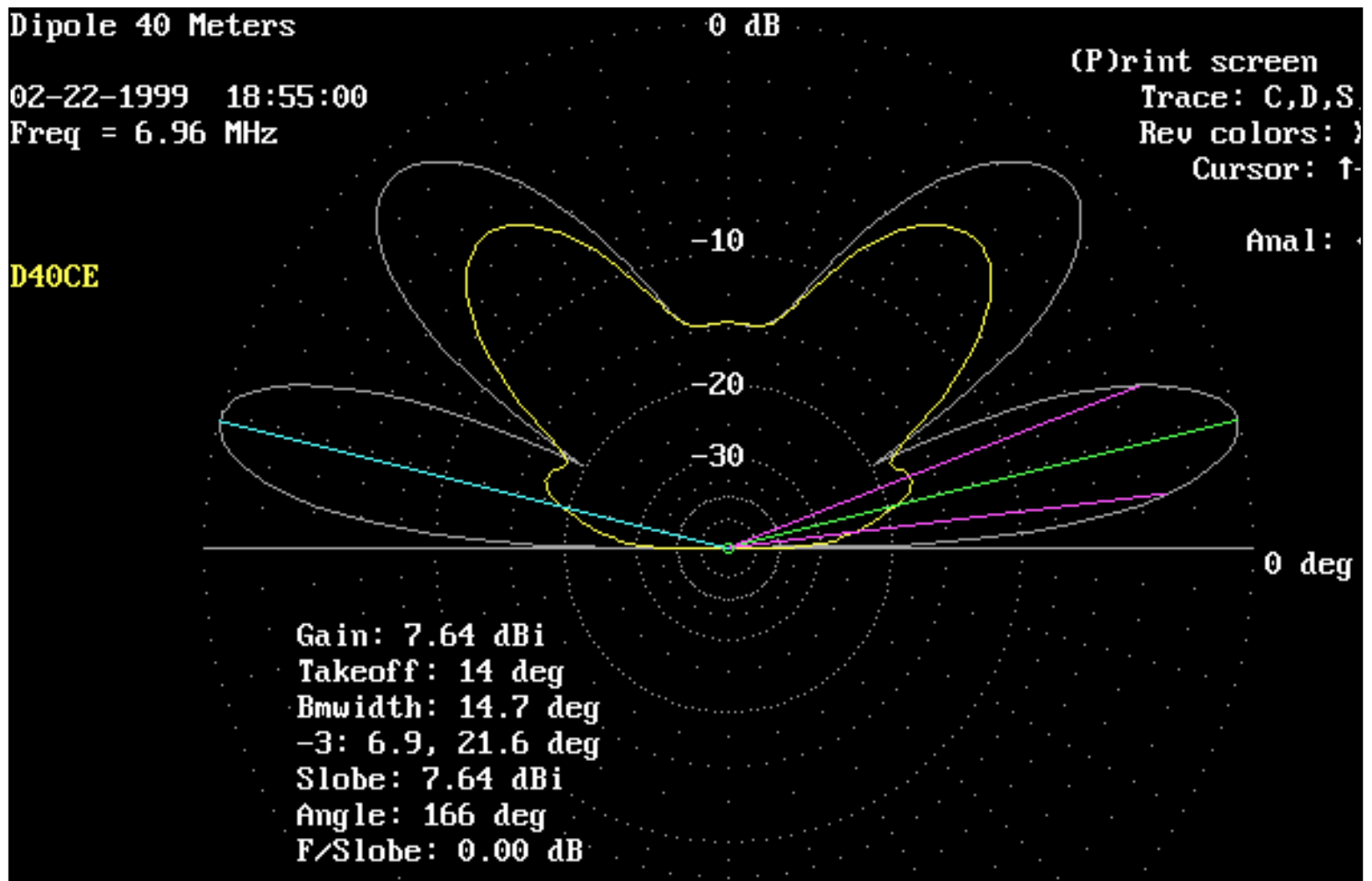

This plot shows the elevation patterns at a height of 0.7 wavelength, or 98 feet.
 White trace is broadside. Yellow trace is axial (off the ends).
 The primary lobe is up to 20 degrees.
 Note the large vertical lobe which has appeared!

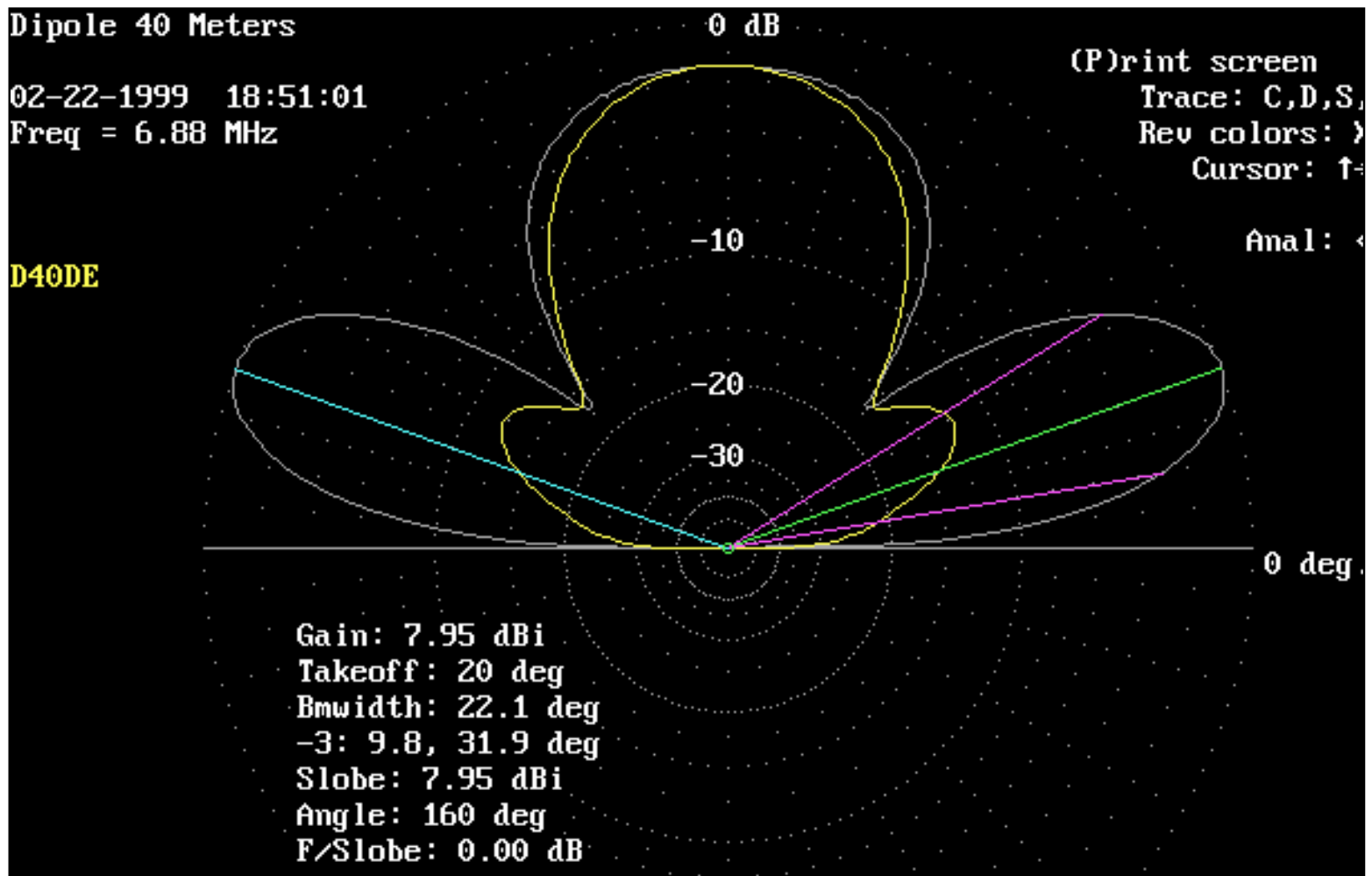

This plot shows the elevation patterns at a height of $1/2$ wavelength, or 70 feet.
White trace is broadside. Yellow trace is axial (off the ends).
Now that's a classical dipole pattern!

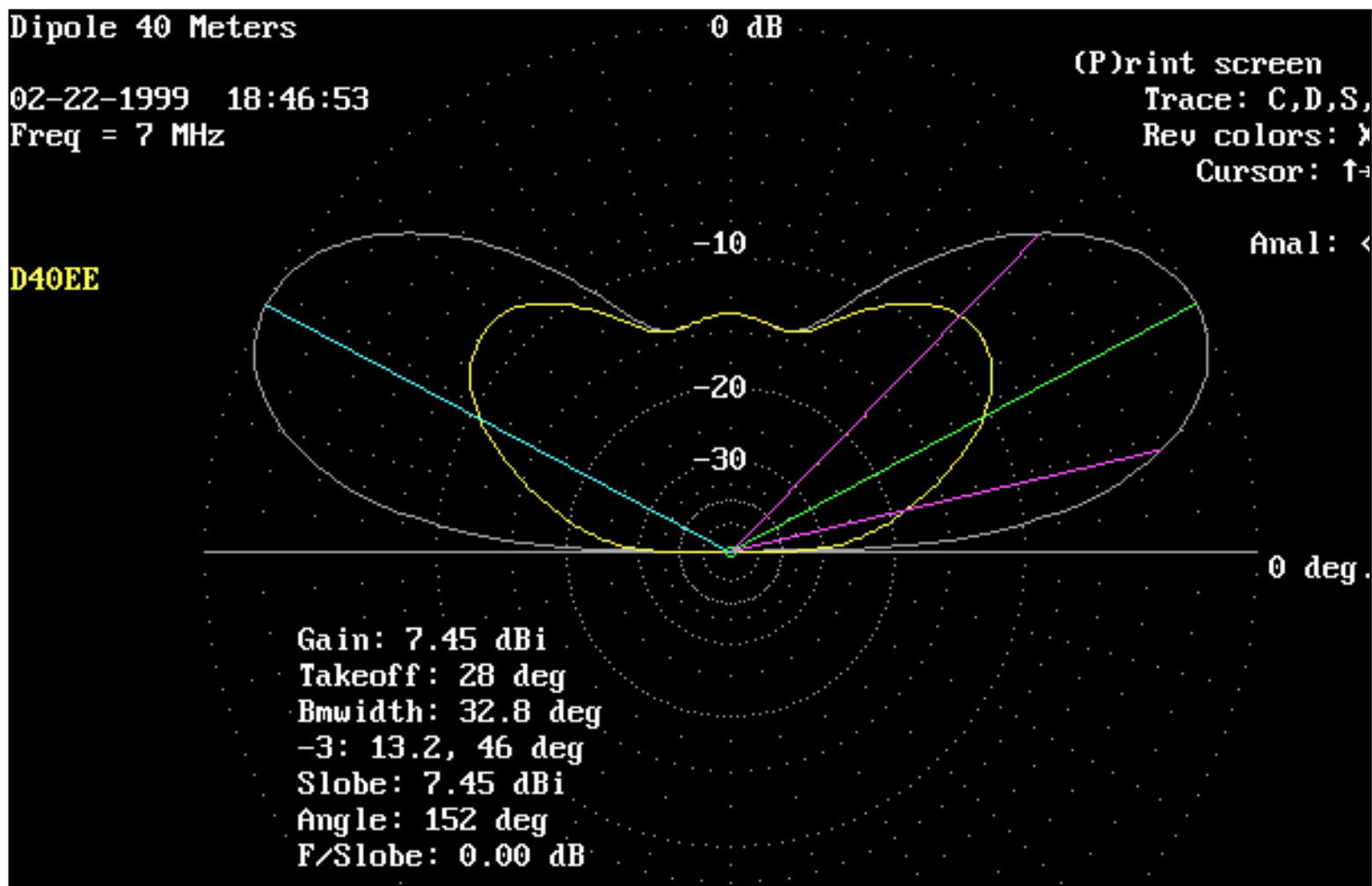

This plot shows the elevation patterns at a height of 0.3 wavelength, or 42 feet.
 White trace is broadside. Yellow trace is axial (off the ends).
 We are entering the "skywarmer" mode here.

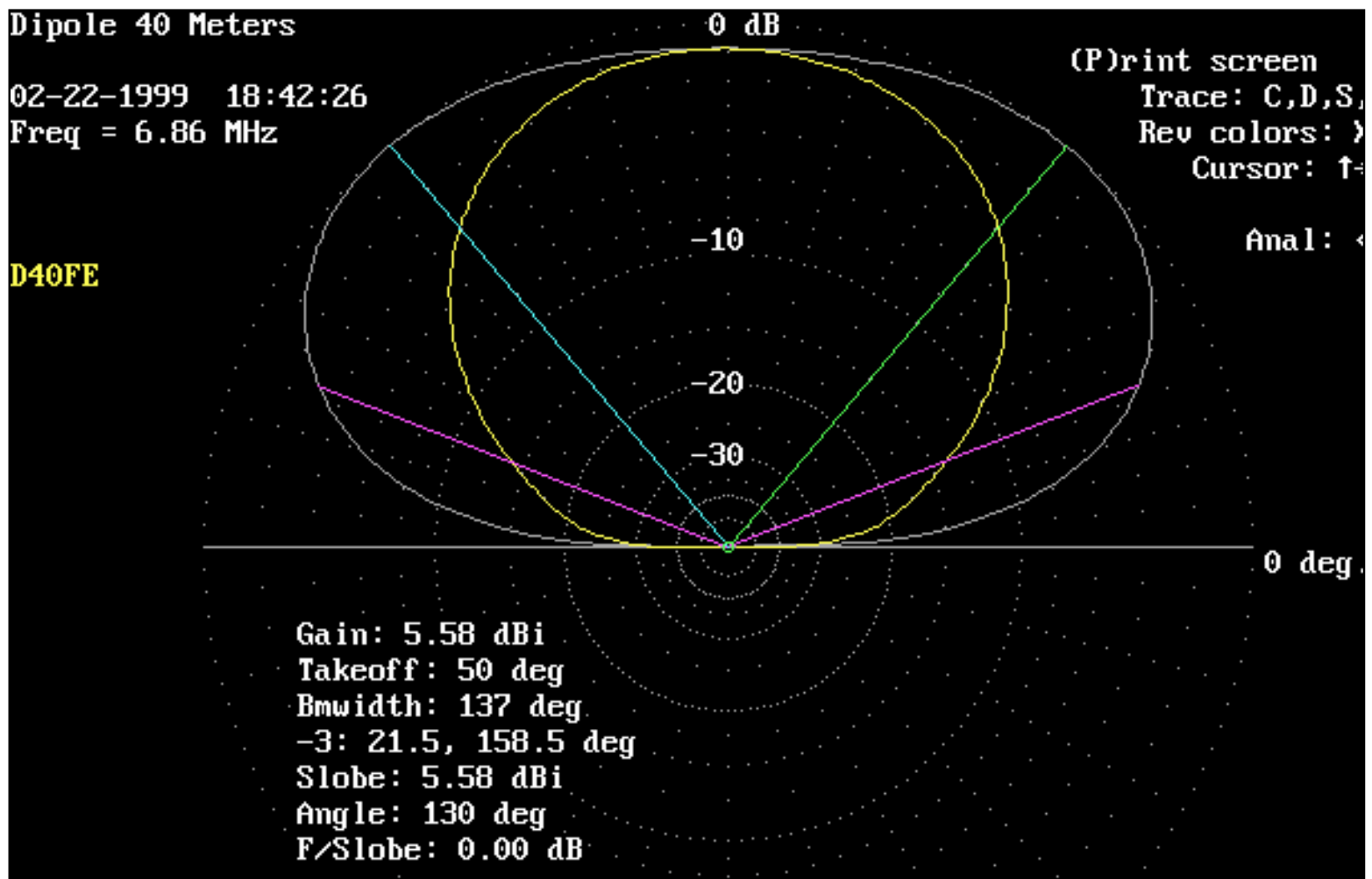

This plot shows the elevation patterns at a height of 0.1 wavelength, or 14 feet.
White trace is broadside. Yellow trace is axial (off the ends).

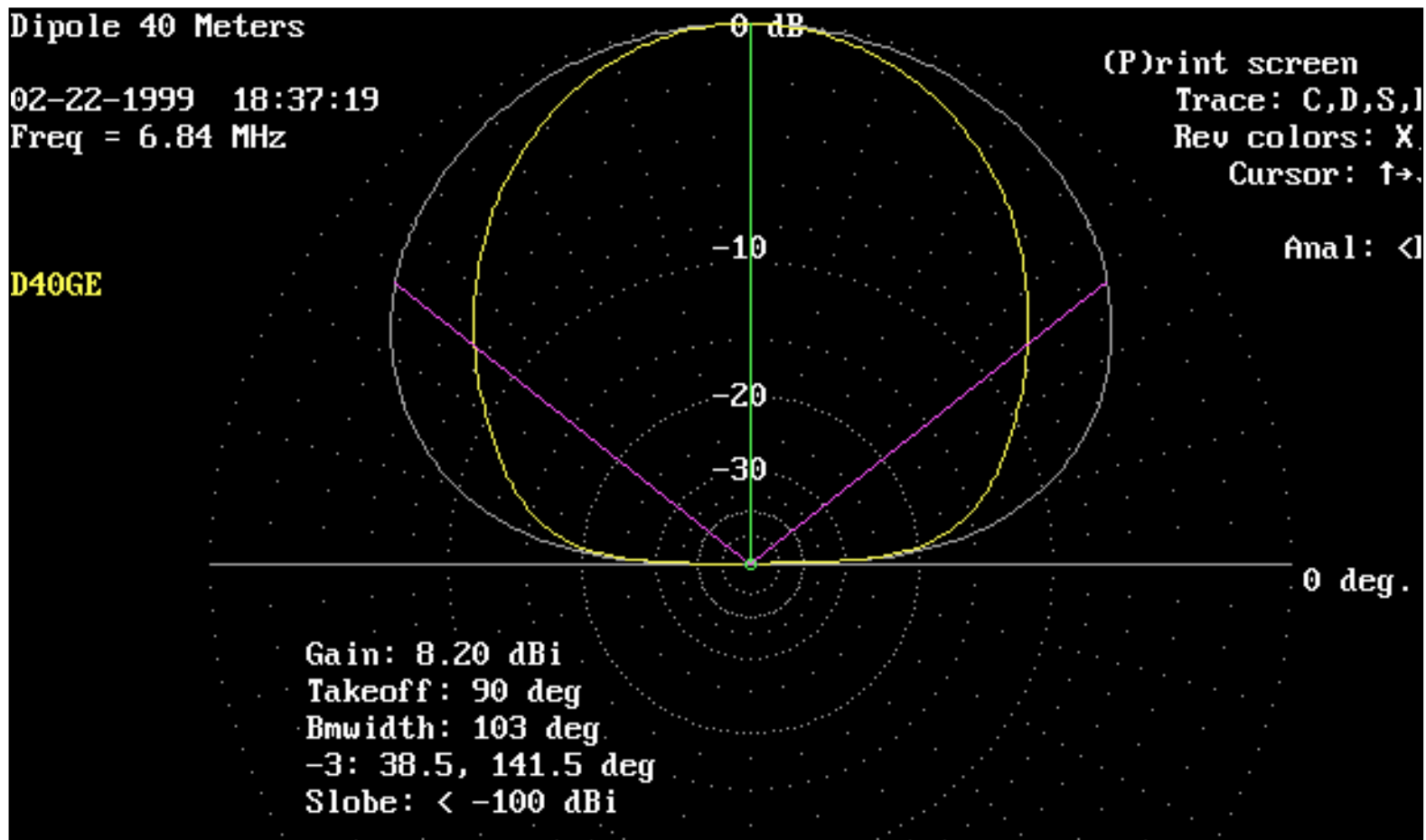

This plot shows comparative elevation patterns, in the broadside direction only,
White trace is for 2 wavelengths, 280 feet.
Yellow trace is for 1 wavelengths, 140 feet.

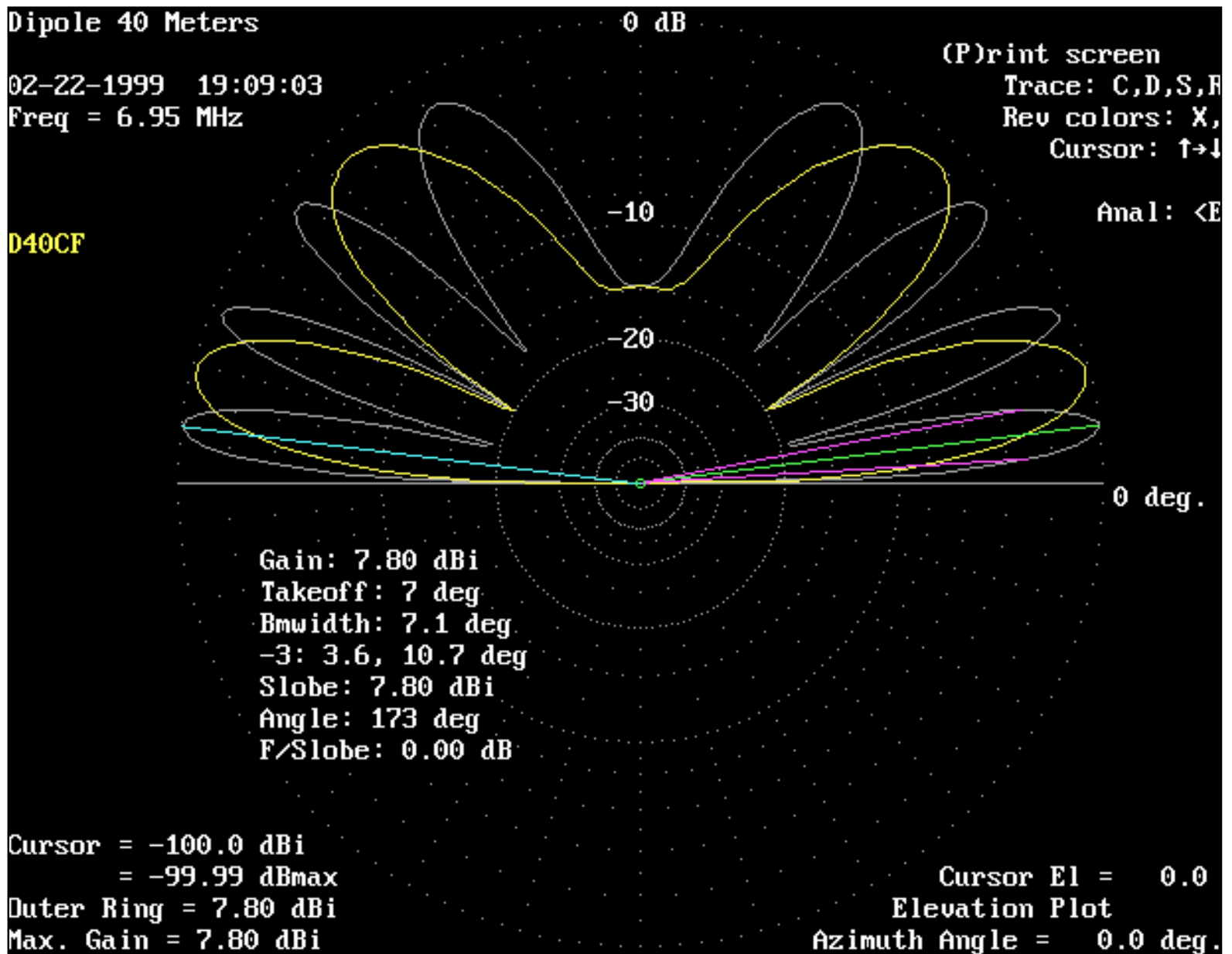

This plot shows comparative elevation patterns, in the broadside direction only.

White trace is for 0.7 wavelengths, 98 feet.

Yellow trace is for 0.5 wavelengths, 70 feet.

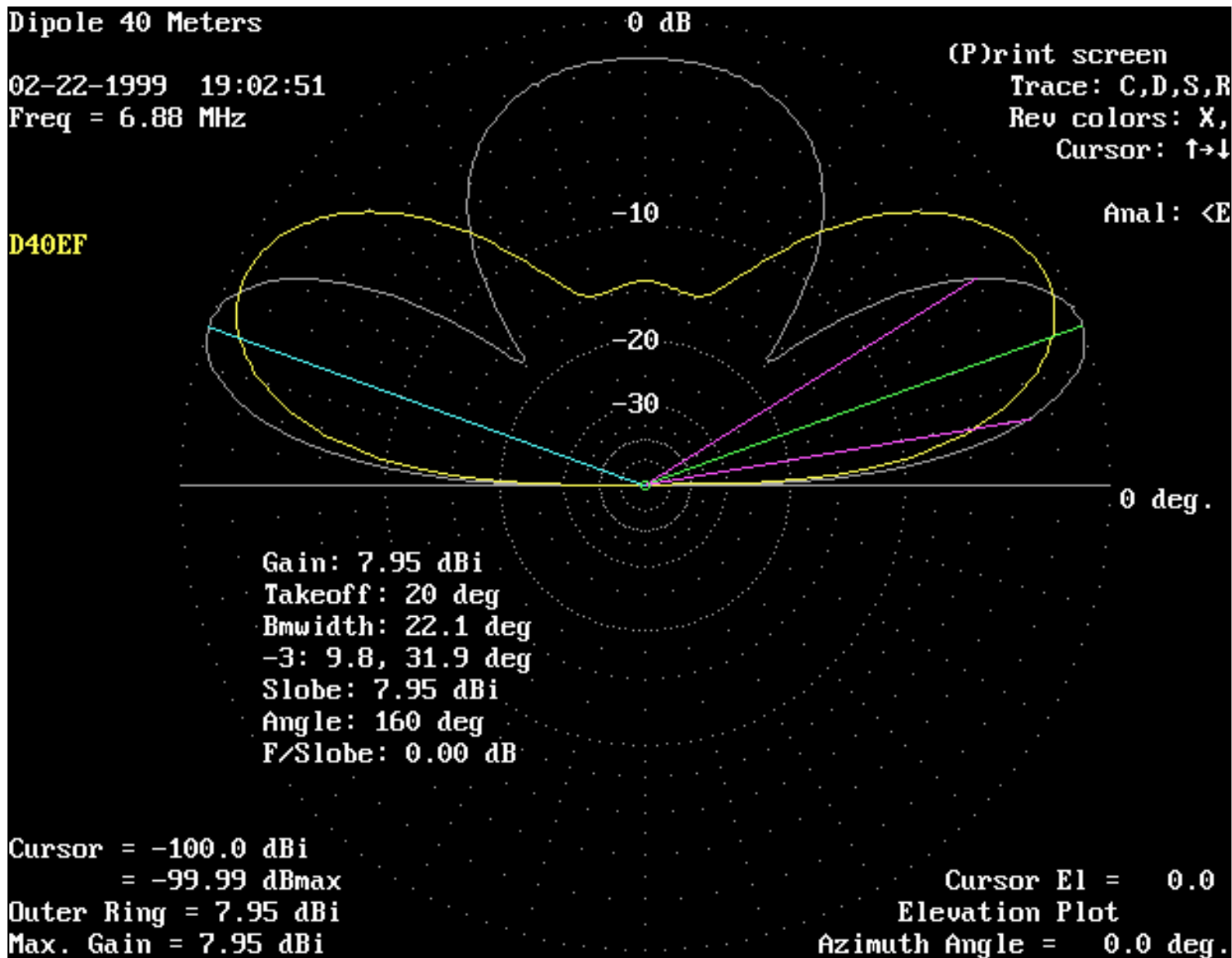

This plot shows comparative elevation patterns, in the broadside direction only.
White trace is for 0.5 wavelengths, 70 feet.
Yellow trace is for 0.3 wavelengths, 42 feet.
Pink trace is for 0.1 wavelengths, 14 feet.

Dipole 40 Meters

02-22-1999 18:48:16
Freq = 7 MHz

(P)rint screen
Trace: C,D,S,R
Rev colors: X,
Cursor: ↑↓

D40FF
D40GF

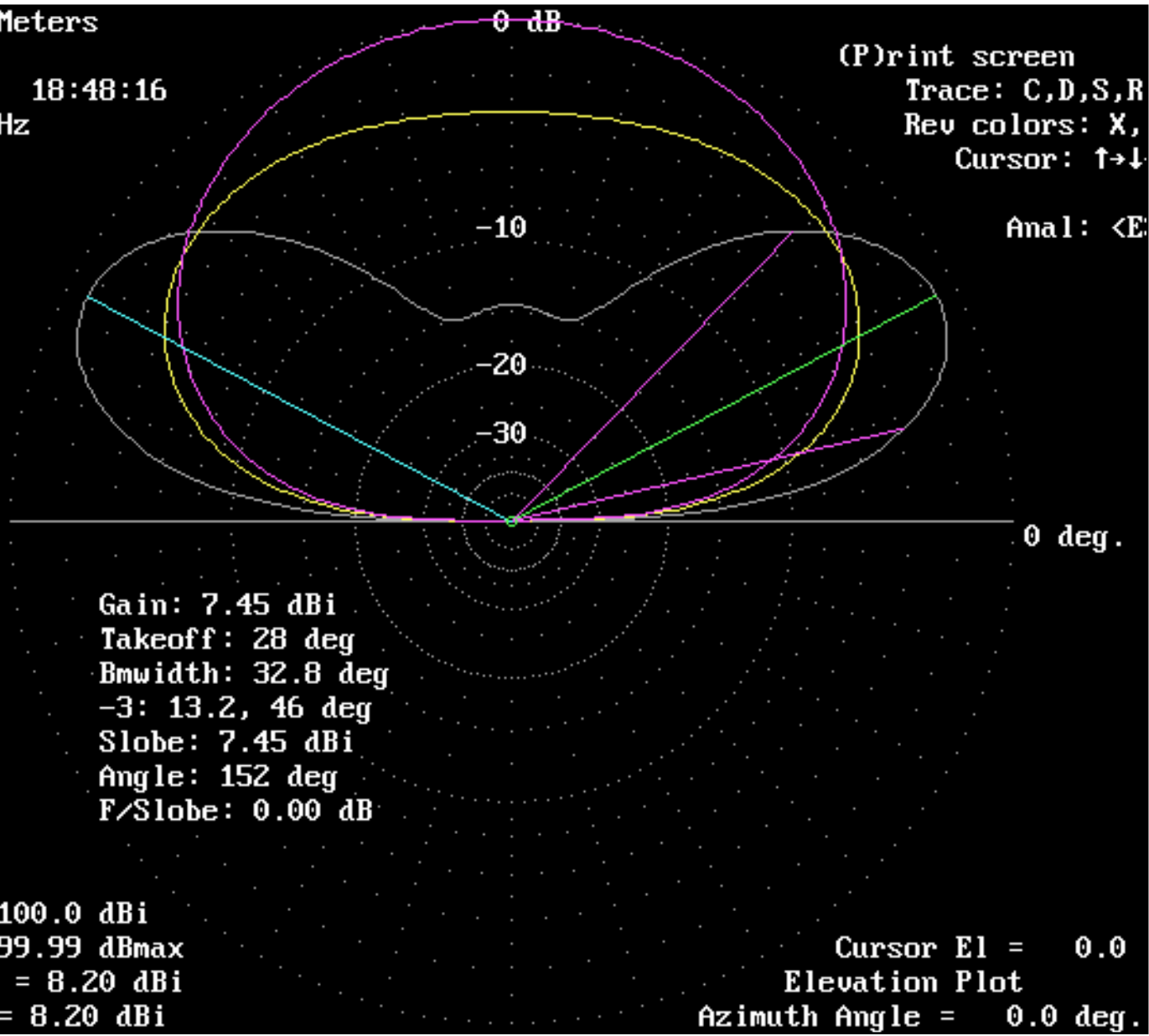

This page is published by Mike Banz, AA3RL as a service to the Amateur Radio community.
Please distribute freely.

The author welcomes any questions, criticisms, or compliments via email.



[email Mike with comments or questions.](#)

File.

ant2.rtf

ant2.html



Ham Radio Operators ID Badge
Engraved with Your Name, Call Sign [Click Here](#)



Find on this site...

[Site Index](#)

•[Exams](#) Search site: Call sign search:
•[Clubs](#)
•[Hamfests](#)
•[Addresses](#)

ARRL Member Login...

Username: Password:

[Register](#)

Quick Links...

•[Join or Renew](#)
•[Catalog & Store](#)
•[ARRL Courses](#)
•[Classifieds](#)
•[Getting Started](#)

[Operating Activities](#)

[Licensing](#)

[News/Bulletins](#)

[Services](#)

[Educational](#)

[Public Service](#)

[Support](#)

[Donate to ARRL](#)

[ARRL Info](#)

[Text-only/Printable](#)

Antenna Tuner Operation

I'm a little confused about how antenna tuners function in terms of reducing antenna system SWR. Is it true that an antenna tuner does not really 'tune' the antenna? And if an antenna is cut to resonance already, what good is a tuner?

Yes, it's true--an antenna tuner doesn't really tune your antenna in the strict sense of the word. It does not, for example, adjust the lengths of your antenna elements, their heights above ground and so on. What an antenna tuner or transmatch does do, however, is transform the impedance at the feed line input to a value that your transceiver can handle (typically 50 Ohm--see Figure 1). When thinking about antenna tuners and SWR, it's important to remember that the tuner has no effect whatsoever on the SWR between itself and the antenna. It's the SWR between the tuner and the transceiver that changes.

In practical terms, all a tuner does is act as a kind of adjustable impedance transformer between the antenna system and the radio. It takes whatever impedance the antenna system presents and attempts to convert it to 50 Ohm--or something reasonably close to that value--for the transceiver. When the transceiver "sees" a 50 Ohm impedance, it is able to load its maximum RF output into the system. That power is transferred through the antenna tuner, to the feed line and, ultimately, to the antenna--minus any losses incurred along the way.

These losses are the reason that the highest efficiency feed-line for each individual case is desirable and why some amateurs use ladder line.

What is the correct way to tune an antenna tuner?

Most antenna tuners have an inductance rotary switch and two capacitors. The capacitors are often labeled ANTENNA and

ARRL Products:
Instructor Support
[\(More\)](#)



[Amateur Radio
Emergency
Communications
Course -- Level III --](#)

Certification Instructors: these manuals are intended for classroom use, as part of the ARRL Certification and Continuing Education Program (ARRL CCE).



[Ham
Radio...Planning
for the Future 2001](#)

-- Proceedings of
The ARRL National
Educational Workshop. July
2001.



[N0AX's Radio
Puzzler -- Online](#)

Special! -- A fun
collection of
challenging logic
problems, puzzles, quizzes,
humorous articles, and more!



[The ARRL
Instructor's
Manual -- For](#)

Technician Class
License Courses.

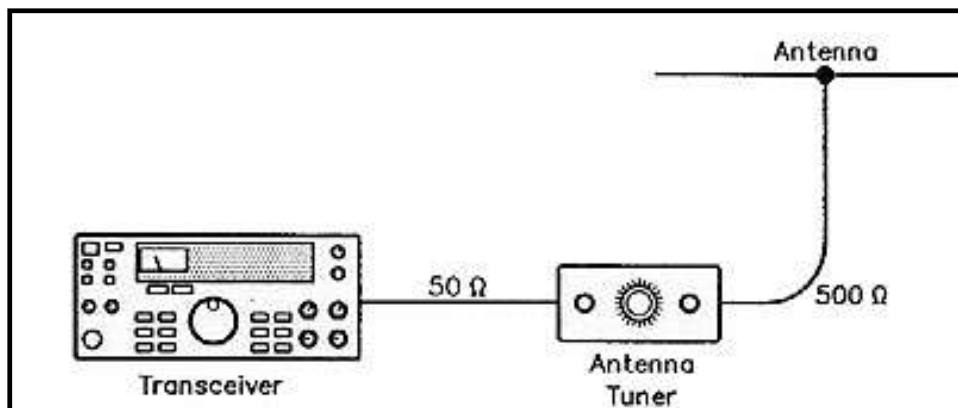

(Figure) (QST February 2000, p. 49)

TRANSMITTER. In some antenna tuners the inductance switch is replaced with a continuously variable inductance, popularly known as a roller inductor.

Let's assume you're using a tuner with an inductance switch, because they are the most common. Place both capacitor controls at their mid-range positions. Don't trust the knob markers if this is your first experience with the tuner; remove the cover and turn the knobs until the moving capacitor plates are only half meshed with the stationary plates. If the knobs are pointing to half scale, consider yourself lucky. If not, loosen their Allen nuts and rotate the knobs so that they point to mid scale. Replace the tuner cover and you're ready to go.

Turn the radio on and, with the ANTENNA and TRANSMITTER controls at mid scale, crank the inductance switch until you hear the loudest noise or signals coming into your radio. Then, rotate the ANTENNA and TRANSMITTER controls until you get to the absolutely loudest noise or signal level on the radio. This should be close to your best tuning spot.

With your rig set to low power, send an ID then transmit a continuous carrier while you tweak the ANTENNA and TRANSMITTER controls for the lowest reflected power reading with the highest output power as read on the SWR meter. You may find that you have to vary the position of the inductance switch a position or two to get your best match. Be gentle to your radio; keep the key-down periods as short as possible.

Depending on the impedance at the antenna input (and the overall design of the tuner) you may not be able to obtain a flat 1:1 SWR on all frequencies and bands.

Plus, a Morse code course. Instructor lesson modules, for use with *Now You're Talking!*



[Amateur Radio
Emergency
Communications
Course -- Level II --](#)

Certification Instructors: these manuals are intended for classroom use, as part of the ARRL Certification and Continuing Education Program (ARRL CCE).

Do You Need an Antenna Tuner?

Maybe yes, maybe no. It all depends on the type of antenna and feed line you're using.

By Steve Ford, WB8IMY
Assistant Technical Editor

There is a great cloud of mythology surrounding antenna tuners, particularly when the conversation turns to what they can and cannot do. Make no mistake, they are useful devices in the right applications. The trick is deciding whether you need one!

When Rigs and Antenna Systems Disagree

Every antenna has an *impedance* expressed in *ohms*. The same is true of the feed line you use to connect your transceiver to the antenna. Impedance sounds like a complicated beast and, to a certain extent, it is. In simplest terms, it is a combination of *inductive reactance*, *capacitive reactance* and garden-variety *resistance*.

It's probably best to avoid a long discussion about the meaning of reactance. This is "New Ham Companion," not the *Proceedings of the IEEE*. If I had several more pages to devote to this article, I'd be more than happy to bore you to tears with reactance theory. For our purposes, think of reactance as opposition to the flow of an ac signal in a circuit. In this case, the ac is the RF generated by your transceiver and the circuit is your antenna system. File this idea away for the moment. We'll come back to it later.

Meanwhile, back at the radio ranch....

The impedance of the antenna depends on a number of factors, including the length, operating frequency, height above ground, proximity of metal objects and even weather conditions (such as ice on the antenna). The impedance of the feed line depends on how the cable is constructed.

Your feed line does more than simply connect your radio to your antenna. It acts as an *impedance transformer*. That is, the impedance of your antenna is transformed by the feed line into the value your radio "sees" when you connect it to the cable. This *system impedance* acts as a load for the energy created by your radio—just like a light bulb is a load for the energy supplied by a battery.

Most amateur transceivers are designed to work with a load impedance of 50 ohms. When your radio sees an impedance of 50 ohms, or something close to it, you're on easy street. You press the mike switch, close the CW key or type on your keyboard and all is right with the world.

But what happens when the impedance isn't 50 ohms? Now you have a situation known as a *mismatch*.

When a mismatch exists, a certain portion of the power generated by your radio is *reflected*—like light is reflected by a mirror. This reflected power comes shooting back down the cable to your radio. When it reaches the radio, it is reflected back toward the antenna. The reflected power combines with the *forward* power being generated at the radio to create

standing waves in the feed line.

By using a *standing-wave-ratio* (SWR) meter, you can measure both the forward and reflected power. A 1:1 SWR reading indicates that no power is being reflected back to your radio. This is good. On the other hand, an SWR of 3:1 or more means that a substantial amount of power is being reflected. This is usually bad. (Don't you love these simple concepts?)

A high SWR can cause considerable RF voltages to develop in the feed line and in the output circuits of your radio. This is a dangerous condition for your rig—especially if it is a modern solid-state transceiver. To prevent this, many radios manufactured within the past 10 years include SWR protection circuits. When the SWR gets too high, these circuits automatically

reduce the output power or, in some cases, shut down the transceiver altogether (see Fig 1). Older tube radios are much more forgiving, but even they can be damaged when operated under high SWR conditions.

If your antenna system presents a serious mismatch to your radio, what can you do? If you connect your transceiver directly, the protection circuitry will drop your output like a rock. Worse yet, you may find yourself on the receiving end of an expensive repair bill. You need to provide a 50-ohm load for your transceiver—regardless of what is really present. One way to accomplish this is by using an antenna tuner.

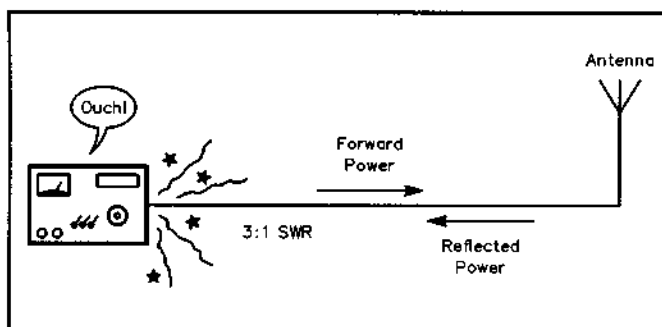

Fig 1—Most transceivers are designed to expect an antenna system impedance of 50 ohms. When the antenna impedance is something other than 50 ohms, a transmission line mismatch occurs and a portion of the RF power is reflected back to the radio. Standing waves are created in the feed line and high RF voltages can develop. When the standing-wave ratio becomes higher than 3:1, your transceiver may be damaged.

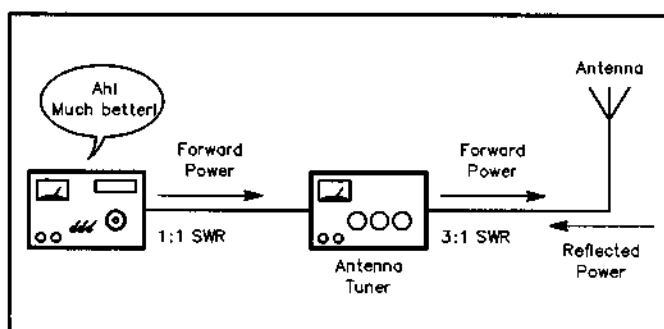

Fig 2—By using an antenna tuner, you can adjust the impedance your transceiver "sees" to a hospitable 50 ohms. The antenna mismatch to the line still exists, but the tuner protects your radio from the RF voltages while allowing it to develop its maximum output.

How Does an Antenna Tuner Work?

In its most basic form, an antenna tuner is simply a network of variable inductors (coils) and capacitors. By adjusting the coils and capacitors, you counterbalance and cancel the effects of the inductive and capacitive reactance at the *transceiver* end of the feed line. (Now you know why I bothered bringing up the subject of reactance in the first place!) As the reactances are canceled, the impedance at the transceiver is transformed to 50 ohms (see Fig 2).

As far as your transceiver is concerned, the load impedance is matched and it's free to dump all of its power into the antenna system.

I bet a number of you are saying to yourselves, "Wait a minute! The impedance at the transceiver side of the tuner is 50 ohms, but it's still some other value at the antenna side. All you've done is shift the mismatch problem from the transceiver to the tuner!"

You're right. The mismatch still exists, but now it's at the output of the antenna tuner instead of the transceiver. By using the tuner, we're protecting the radio while still allowing it to develop maximum output. If the tuner is well designed, it should be able to handle the RF voltages and currents caused by the high SWR.

Of course, the reflected power is still bouncing back and forth between the antenna tuner and the antenna. Some of this power is lost in the feed line. If you're using low-loss feed line, however, most of it is radiated at your antenna. In the meantime, your transceiver is happy and you're happy. Who could ask for more?

Use an Antenna Tuner if...

...you want to feed your antenna with open-wire line.

Open-wire line (or ladder line) offers extremely low loss at HF frequencies (much better than coaxial cable). One problem is that open-wire line is *balanced* while your transceiver output is *unbalanced*. You need to use an antenna tuner with a built-in *balun* to form a bridge between the balanced line and the unbalanced output of your radio. A balun is a type of transformer that converts balanced feed lines to unbalanced, or vice versa. (**B**ALANCED to **U**NBALANCED. Get it?) Most antenna tuners use 4:1 baluns that also convert the impedance of open-wire feed lines to a value that the tuner can handle.

...you want to operate your antenna on bands other than those it was designed for.

When you attempt to use, say, a 40-meter dipole on 10 meters, a big mismatch will develop, along with a high SWR. By using an antenna tuner, you may be able to create a 1:1 SWR at your transceiver. (I say "may" because the mismatch can sometimes be so great that it is beyond the capability of your tuner to handle.) The high SWR may cause substantial loss in a coaxial feed line, but at least you'll radiate some power at the antenna.

...your antenna has a narrow SWR bandwidth on some bands.

Some types of multiband antennas do not offer low SWRs from one end of each band to the other. There is usually a range—expressed in kilohertz—where an SWR below 2:1 can be achieved. For example, a multiband trap dipole may offer an SWR of 2:1 or less from 3600 to 3800 kHz. That's an SWR bandwidth of 200 kHz. If you try to operate above 3800 kHz or below

3600 kHz, you'll encounter an SWR higher than 2:1 and your radio may become displeased. With an antenna tuner, you can operate outside the SWR bandwidth and still load the full output of your radio into the antenna system.

Don't Bother with an Antenna Tuner if...

...your SWR is 1.5:1 or less at the frequencies you operate most often.

An SWR of 1.5:1 or less is not serious and does not require the assistance of an antenna tuner. Most modern rigs will tolerate a 1.5:1 SWR just fine. In fact, many will be happy at an SWR of 2:1. If you are using a good-quality feed line, the loss caused by an SWR of 1.5:1 or even 2:1 isn't enough to worry about at HF frequencies. Many hams are obsessed with providing an absolute 1:1 SWR for their radios at all times. Apparently they also have money to burn!

...you have a high SWR at VHF or UHF frequencies.

VHF/UHF antenna tuners are available, but my advice is to save your money. Remember that an antenna tuner massages the antenna system impedance *at the transceiver*. The mismatch still exists and the SWR is still high at the antenna side of the tuner. Even the best coaxial cables have significant losses at VHF and UHF when the SWR is high. A VHF/UHF antenna tuner will make your radio happy, but most of its power will never make it to the antenna. The best approach is to correct the mismatch at the antenna by adjusting whatever tuning mechanism it provides. If the antenna cannot be tuned, check the cable for defects and make sure you've installed the antenna properly.

...you're interfering with TVs, telephones and other appliances in your neighborhood.

Despite what you may have heard, an antenna tuner will not necessarily cure your interference problems. It's true that most antenna tuners will reduce the level of *harmonic radiation* (signals your radio generates in addition to the ones you want), and if the interference is being caused by

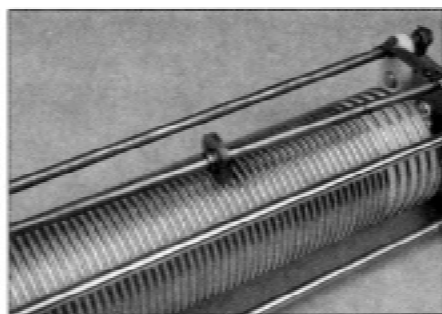

Fig 3—This is a typical roller inductor. Notice the wheel that rolls along the coil windings. As the wheel moves, the inductance changes.



harmonics, a tuner may help. Most interference, however, is caused by RF energy that's picked up indirectly by cables or wires, or directly by the device itself. By using an antenna tuner, you'll probably radiate more energy at the antenna than you did before. That may make your interference problem worse!

Looking for Mr Goodtuner

So, you've decided that you need an antenna tuner after all. Antenna tuners come in all shapes and sizes. What features should you consider?

□ **A built-in SWR meter**—An SWR meter of some type is a must if you want to use an antenna tuner. When adjusting your tuner, you need to keep your eye on the *reflected power* indicator. Your goal is to reduce the reflected power to zero—or at least as close as you can get. When the reflected power is zero, the SWR is 1:1 at your transceiver.

Many tuners feature built-in meters. If not, you can purchase one separately. Your radio may even have its own SWR meter.

□ **A roller or tapped inductor**—More expensive tuners feature a variable coil called a *roller inductor*. As you turn the front-panel inductor knob, the coil inside the tuner rotates. A metal wheel rolls along the coil like a train on a railroad track. As the wheel moves along the coil, the inductance increases or decreases.

Less expensive tuners do not use roller inductors. Instead, there is a coil with wires attached at various points. On the front panel, a rotary switch selects the wires. According to how the inductor is wired in the circuit, selecting one *tap* or another

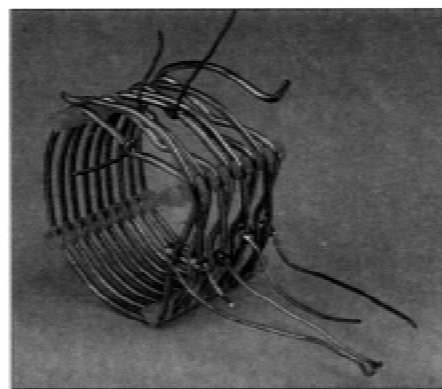

Fig 4—Tapped inductors have wires attached at various points. By selecting a particular wire, you get a fixed amount of inductance.

varies the inductance. This is known as a *tapped inductor*.

There are advantages and disadvantages to both approaches. Roller inductors offer the best tuning performance, but they are subject to the woes of mechanical wear and tear. For example, if corrosion builds up on the wheel or the coil windings, the electrical quality of the connection will deteriorate. Roller inductors are also cumbersome to use. You may have to twist the control many times when moving from one band to another.

Tapped inductors are easy to use and free of mechanical problems (unless the switches get dirty). However, you may find that they restrict the operating range of your tuner. When you turn the switch, you select a *fixed* amount of inductance. You can't easily change it to tune a particularly difficult mismatch situation.

□ **A built-in balun**—If you intend to use an open-wire feed line, buy a tuner with a built-in 4:1 balun. These baluns often dissipate quite a bit of heat, so always choose a large balun over a small one.

□ **Multiple antenna capability and dummy loads**—Some tuners offer the ability to connect more than one antenna. This is handy in all sorts of applications. Let's say you have a vertical antenna for 40-10 meters and a wire dipole for 80 meters. You can connect both feed lines to your tuner and easily switch between them.

Built-in dummy loads are convenient, but not necessary. A dummy load is a resistor (or group of resistors) that absorbs the output of your transceiver while allowing very little energy to radiate. It's used for making transmitter adjustments and other

tests. If your tuner lacks a dummy load, you can purchase one separately.

□ **Automatic operation**—Most transceiver manufacturers offer *automatic* antenna tuners. These tuners are usually built in the radio itself, or they're offered separately. Automatic tuners are convenient when you need to change bands or frequencies quickly. You simply push a button and your tuner adjusts its coils and capacitors to achieve the lowest SWR. Some automatic tuners sense when you've changed frequency and will readjust immediately! (You don't have to lift a finger.)

Automatic antenna tuners are expensive and their tuning range is limited. If your operating style requires you to jump from band to band rapidly (contesting is one scenario), consider an automatic tuner. Otherwise, conserve your cash and invest in a manual tuner.

A Word About Power Ratings

If your transceiver produces only 50 or 100 watts of power, a 200- or 300-watt tuner should do the trick, right? Well...yes and no. Remember what we said about mismatches causing high RF voltages in the tuner? If you're trying to use your tuner in a high-SWR situation, the RF voltages at the tuner may cause an unpleasant phenomenon known as *arcing*. That's when the RF energy literally jumps the gaps between the capacitor plates or coil windings. When your tuner arcs, you'll usually hear a snapping or buzzing noise. The reflected power meter will fluctuate wildly. Interference to your TV and other devices will increase dramatically. You may even see brilliant flashes of light inside your tuner!

Arcing is obviously bad news for your tuner. It's your tuner's way of saying, "Stop! I can't handle this mismatch!" There are two cures for arcing: reduce your output until it stops, or get a tuner with a higher power rating.

High-power tuners use large capacitors and coils. The gaps between the plates and windings are greater, making it more difficult for an arc to occur. If you can afford it, you're always better off buying a tuner with a 1.5 kW rating or better. (The exception is QRP operating where you're running low power levels.) A hefty tuner costs more, but it will serve you well in the long run.

Buy or Build?

As you comb through the advertising pages of *QST*, you'll see many new antenna tuners for sale. The prices are often reasonable and the quality is usually good. Keep your eyes open for used tuners, too. If an old tuner is in decent condition, it's every bit as usable as a new one.

If you like to build things, however, consider an antenna tuner as your next project. Antenna tuners are relatively easy to construct. You can find capacitors and coils at hamfest flea markets at low prices. Even roller inductors—the most expensive part of a roller-inductor tuner—can be found for less than \$40 if you look carefully.

Your chances of success with an antenna tuner project are excellent. You have to try pretty hard to build one poorly! Best of all, you'll have the satisfaction of using a piece of equipment that you've put together yourself. The *ARRL Handbook* offers several tuner designs you can try. Heat up your soldering iron and go to it! QST

Radio Tips:

Log it or Lose it

Back in the old days (not all that long ago!), the FCC required every amateur to keep a detailed station log. (In addition to regular QSOs, hams even had to log unfruitful CQ calls.) And although we're not required to keep a log nowadays, an accurate station log is useful not only today, but tomorrow, too.

We all have things we like to keep track of: states and countries worked and confirmed; information for awards; or the names and addresses of our on-the-air friends. A well-kept station log is invaluable in your quest for the Worked All States or the DX Century Club (DXCC) awards. In addition to keeping a running list of states and countries, your logbook is the perfect place to keep detailed information on a wide range of subjects.

Your logbook is also a good place to keep notes on modifications to your equipment. Not only will the information be easy to find for future reference, it will be easier to note the effects of such changes by referencing contacts before and after.

How does your new loop antenna compare with your old trap vertical? Check out the signal reports in your logbook and you'll have a good idea!

DXers often refer to their logs when trying to work into specific parts of the world. When is the best time to work Africa in the winter? A quick check of last year's log entries will probably turn up the required information.

While you're at it, why not keep other changes in your log? When you upgrade, note it in your log. When you get a new rig or put up that long-awaited tribander, write it down. Ten years down the road, your log entries will bring back a flood of memories!

Speaking of memories, poring through your old logbooks can be a lot of fun. You'll come across your first QSO and remember how nervous you were, or you'll come across rare DX stations you've worked, pileups you've busted or the first time you worked someone special. Reliving those events is almost as much fun as it was when it happened!

Computers have become quite popular

in ham shacks across the country—especially those belonging to contesters and DXers. If you have a PC in your shack, you might want to consider keeping your station log on your computer. A number of suitable programs are available. Check the ads in *QST*. Logging programs may also be available through your local club or computer user's group. If you're into programming, consider writing your own logging software.

If you do go the computer route, remember to keep regular backups and a hard copy of your log information—otherwise, the benefits of having instant access may be lost if your data disks are lost or damaged.

If computerized logging isn't your thing, *The ARRL Logbook* is just what you've been looking for. Used by thousands (millions?) of hams over the years, the latest version is available from the ARRL for \$3.50. It has room for nearly 1000 QSOs and includes useful information such as Q signals, a time-conversion chart, the ITU phonetic alphabet, an RST chart, international call sign prefixes and more.—NT0Z

[GO TO HOME PAGE](#)

[Teory](#) [Practice](#) [My Balun](#)

ABOUT BALUN

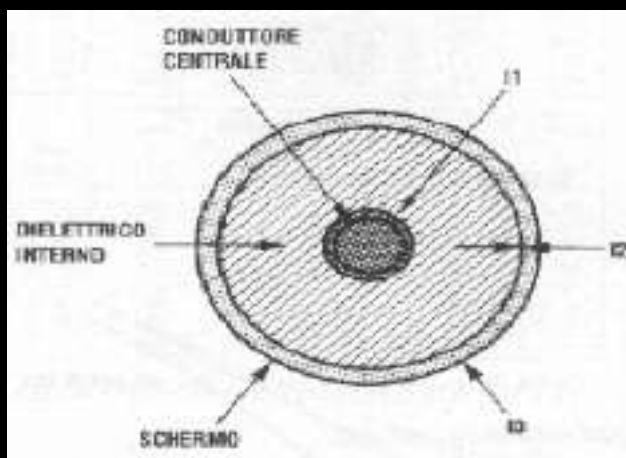

Maybe baluns are still a mystery for hams; the only way to understand it is learning what it is and how to use it.

The word balun means balanced-unbalanced: it's used to adapt a balanced device to an unbalanced one; in a balanced device (as larger type of antennas) we have on both terminal the same voltage respect to the ground (if not so it's an unbalanced device);

a dipole with direct feed is balanced, a coaxial cable is unbalanced.

So, when we connect a balanced device to an unbalanced one the following occurs:

we have a dipole with coaxial cable direct fed (i.e. RG213); normally, transmitting, there are 2 currents on the cable:

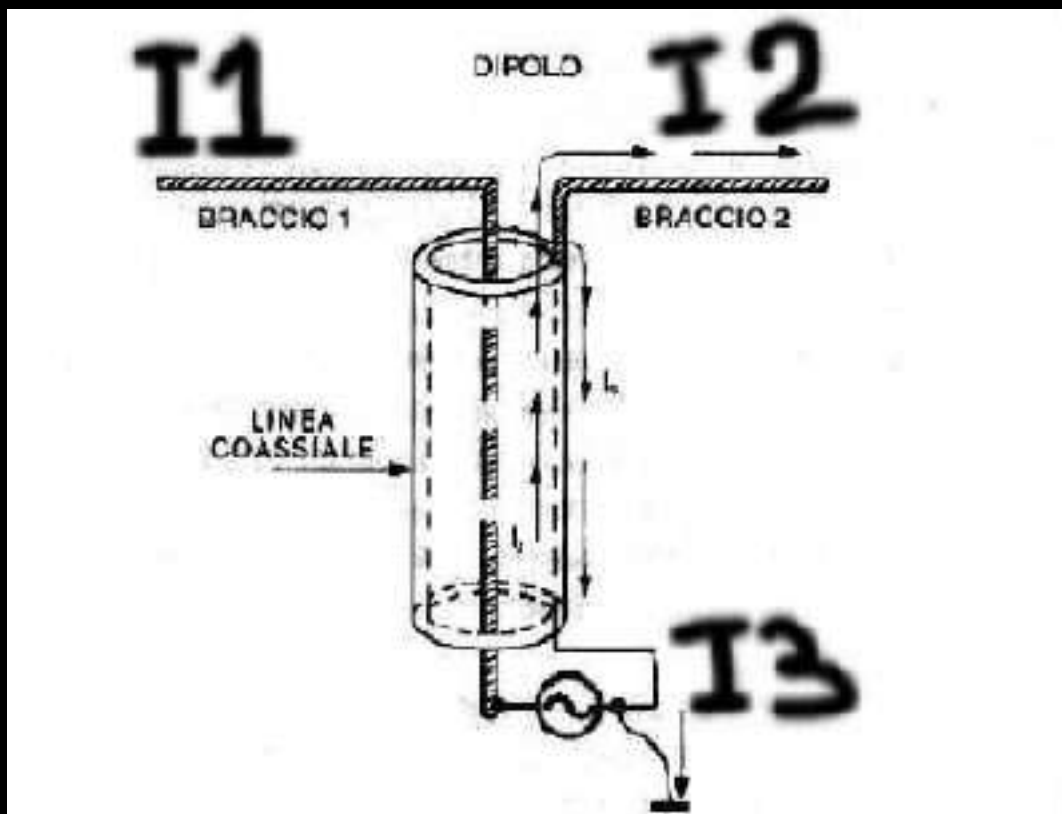

1. I_1 , which flows through the central wire of coaxial cable and from transmitter goes up to the dipole;
2. I_2 , which flows (for the skin effect) on the inside part of the copper shield;

The two currents, equal and opposite, humble itself and we have no radiation from coaxial cable.

The two currents comes on the dipole to be irradiated; part of it comes back; the one on the shield comes back through the external side of the shield (no more the inside: so we have 2 current on the shield, I_2 and I_3); the value of this current (which we'll call I_3) depends to the impedance value of the external side of coaxial cable respect to the ground (in a word if it will find high or low resistance);

if impedance will be high, I_3 will find high resistance and its value will be low; if impedance will be low, resistance will be low and I_3 value will be high; in this way I_3 will radiate RF and the external side of the coaxial cable will radiate as a third wire of dipole: it's as we have a dipole with 3 wire ([see picture 1](#)); as consequence the radiation pattern will be distorted ([see picture](#)

2);

the big problem is that this new wire is often near TV and telephon cables irrading directly on those: so we have more probabilities to cause TVI.

This new wire, when its impedance is low, change the dipole impedance so we can have high S.W.R; this is the reason why (without balun) varying the coaxial cable length the S.W.R. changes.

Let's see now why use a balun; to delete this current I3, we need an high impedance for RF on the external side of coaxial cable; so we have high impedance casually for some cable length (odd multiple of 1/4 lamda) or using a balun: so the first reason to use a balun is TO AVOID THAT ON THE EXTERNAL SIDE OF COAXIAL CABLE FLOWS A CURRENT I3. The simpler balun is a coil with some coaxial cable turns just belowe the antenna feed point: this inductance make the cable impedance (we mean the external side of cable shield) higher so that the RF current will find an high resistance and its value will be very low (that will not disturb I2 and I1 which flow inside the coaxial cable).

[Continue...](#)

LAST MODIFIED:**Wednesday, 30-Jun-2004 19:39:10 PDT**

CHOKE BALUN

YOU ARE HERE: [HOME](#) > [ANTENNAS](#) > CHOKE BALUN

WHAT IS A CHOKE BALUN?

My friend Jim Duffy [once said](#) "Whatever antenna you chose, if it is fed with coaxial cable you should use a choke balun. This will prevent the feed line from becoming part of the antenna which can cause all sorts of problems. There are many designs to chose from. My favourite is an air core balun wound from coax".

Essentially, a choke balun is designed to "divorce" your antenna from the feed line. If your feed line is coaxial cable then you don't want it to be part of your antenna. You want to be able to deliver all your power to the radiator itself, i.e. "the antenna". A choke balun does this admirably.

Got a question on this topic?

If you are involved in electronics then consider joining our ["electronics Questions and Answers"](#) news group to ask your question

there as well as sharing your thorny questions and answers. Help out your colleagues!.

The absolute fastest way to get your question answered and yes, I **DO** read most posts.

This is a mutual help group with a very professional air about it. I've learn't things. Not for absolute newcomers to ask questions BUT it is an excellent learning resource for lurkers.

RELATED TOPICS ON AN Choke Balun

[earlier tutorial on Active Receiving Antennas](#)

[Newer Active Receiving Antennas tutorial](#)

[antenna basics](#)

[low pass filters](#)

[high pass filters](#)

[narrow band filters](#)

[reactance tutorial](#)

[earth dangers](#)

[baluns](#)

[impedance](#)

[inductance](#)

YOU ARE HERE: [HOME](#) > [ANTENNAS](#) > Choke Balun

the author Ian C. Purdie, VK2TIP of www.electronics-tutorials.com asserts the moral right to be identified as the author of this web site and all contents herein. Copyright © 2000, all rights reserved. See [copying and links](#). These electronic tutorials are provided for individual private use and the author assumes no liability whatsoever for the application, use, misuse, of any of these projects or electronics tutorials that may result in the direct or indirect damage or loss that comes from these projects or tutorials. All materials are provided for free private and public use. Commercial use prohibited without prior written permission from www.electronics-tutorials.com.

Copyright © 2000 - 2001 - 2002, all rights reserved. URL - <http://www.electronics-tutorials.com/antennas/choke-balun.htm>

Updated 29th January, 2002

webmaster@electronics-tutorials.com

Antennas

[[Home](#)] [[Balun and Transformer Core Selection](#)] [[Crossfire Phasing](#)] [[Detuning Towers](#)]
[[Combiner and Splitters](#)] [[E-H Antenna](#)] [[Omega and Gama Matching](#)] [[Radiation Resistance](#)]
[[Receiving](#)] [[Transmitting](#)] [[Transmitting Baluns](#)] [[toroid balun winding](#)] [[Traps](#)]
[[Loading Inductors](#)] [[Inductors and Loading Coil Current \(Mobile and Loaded Antennas\)](#)]
[[Mobile Antenna FS Comparisons](#)] [[Phasing Systems](#)] [[Sleeve Baluns](#)]
[[Baluns on Log Periodic Antennas](#)] [[Snap on core material data](#)] [[Short dipoles and problems](#)]
[[End-fed vertical j-pole and horizontal zepp](#)] [[Ground resistance measurements](#)]

Multiple Articles at:

Receiving: Contains information in many articles. Receiving antennas including Beverages and Beverage Antenna Construction, Loops, K9AY, Pennant, Flag, EWE, Slinky Beverage Antennas, vertical arrays, magnetic loop antenna, and terminated loop arrays

Transmitting: Contains information on various transmitting antennas

Single articles:

Balun and Core Selection: Contains information on core selection for transformers and baluns

Baluns, Sleeve balun: How they work

Baluns, transmitting: What they do, how they do it, and how to test them

Balun, Toroid: Winding style, debunking split-winding will improve performance

Crossfire Phasing: Contains information on cross fire phasing and why it is superior for broad bandwidth arrays

Combiner and Splitters: Contains information on Magic-T splitters and combiners, how they work and what they do

Detuning Towers: A quick explanation of how it works and the incorrect idea that you adjust for minimum current! Pass this along, it is a major error to tune for minimum current!

EH antenna: the E-H and CFA antennas. How they work.

Inductors, Loading: A brief tutorial on loading inductors

Mobile and Loaded Antennas: Small loaded antenna systems

(Related page: [Inductor spice model](#))

Omega and Gamma Matching: Contains technical information on Omega and Gamma matches and matching, impedance limits, component selection, component failures

Radiation and Fields: What the terms we use actually describe

Radiation Resistance: A revised (as of Feb 14, 03) tutorial on radiation resistance and how it is used and misused

Traps: Measurements and operation of traps and trap antennas. Including trap antenna loss.

 since May 2004

©2003,2004 W8JI

AMANDX PRESENTS



CHOOSING WIRE FOR AN ANTENNA



One of the most asked questions when it comes to antennas is what kind of wire should I use. The answer is as varied as the people who put them up. Over the last 28 years I have used or have seen used every kind of wire used to make an antenna. Just one disclaimer the information below is referring to antennas used for listening and NOT transmitting.

Stranded or Solid

I have seen both used with great success. Stranded wire is as a rule (and we all know rules are made to be broken) easier to work with and can at times be stronger. Stranded wire is usually more flexible so if you are not putting out a straight wire or bringing it into a house or apartment it may be superior to solid core wire. Solid wire is at times (especially with thinner wire) easier to break.

Coated or Bare

Wire with a coating is called insulated while bare wire is uninsulated. For antennas I do prefer the coated or insulated wire. The reason for this is that coated wire can be easier to work with as if it touches something conductive such as metal it is OK. Bare wire must be kept away from anything conductive to work properly. If bare wire comes into contact with anything conductive that material becomes part of the antenna. This can ruin an antenna's pattern or worse yet a ground system. This latter matter can cause an antenna to short out or worse yet cause damage to a radio due to static discharges. The choice would be yours as the coating or insulation will NOT decrease the signals received. If radio signals can go through your brick wall the tiny amount of plastic or rubber used to coat the wire will not bother your reception.

Thickness

The thickness of wire is measured by its gauge. The higher the gauge number the thinner the wire. I have used wire any where from 24 to 16 gauge over the years. Now the very thin high gauge 24 or 22 wire was used in pairs to give it some strength. No use putting out an antenna and have

the

first gust of wind tear it up. Wire of 18 or 16 gauge is quite good. I

often use

lamp cord or light indoor extension cord wire. This is insulated and cheap to buy at any hardware store. Hey you can be frugal and buy half the wire you need and split the wires to give you the length you need on a heavier gauge wire that is twinned like the lamp cord. If you live in areas that

are

subject to bad weather especially high winds or ice storms heavier gauge wire should be used so it can with stand the elements if the antenna is up

in

the air.

Copper vs Everything Else

In my humble opinion it matters not which you use. I have used everything from copper to aluminum to mystery metal over the years. I have never noticed any difference in the signal strength obtained from different types

of

wire. Go with the price on this topic depending on what you can obtain at your location.

Simple rules to follow:

Once you pick the wire you want make sure you have thought these points out:

must.

If a wire is going to be left on the ground coated/insulated wire is a

If a wire is on snow you can use either as snow in an insulator.

If a wire is up in the air and away from anything conductive you can use either type.

If up in the air and near or touching anything conductive you must use coated/insulated wire.

or

If you live in areas that are subject to bad weather especially high winds ice storms heavier gauge wire should be used so it can with stand the elements.

OK now go out and put up something. Experimenting is half the fun in this hobby.

Life span of an antenna...one man's joking opinion:

Well, generally it depends on hours spent listening.

The antenna converts electro-magnetic energy into electrical energy, which is basically electrons moving into your radio.

There are only so many electrons in each inch of copper wire, so when they've been sent downstream into your radio, the wire will become "ionized" and deteriorate and probably fall down. This explains why, when you come home one day, your antenna is on the ground (see below).

What happens to all those electrons, you ask. Well, they migrate into your radio and accumulate. In older tube radios, there was a "grid leak" resistor circuit which allowed the electrons to fall on the ground. Now you can't see them, but they're there. As more pile up, they slide into your back yard.

Tube radios, because of the "grid leak" last a lot longer than solid state radios, which stop working when enough electrons have piled up inside to short it out.

Now those electrons in your back yard want to get back into the copper wire, so they "pull" the antenna down to be re-united with it. Since the antenna is high, and they're on the ground, this attraction is not strong, but on a windy day, the electrons get lifted from the ground towards the antenna, pulling it down again. The wind oftens brings in free electrons from your neighbor's homes (from TVs, etc), so there may be a lot of these things around. If too many electrons get lifted up all at once, they overload the antenna, causing a heat mark, or worse getting back into the radio. Now this is why your antenna usually falls down on windy days.

At least, that's how I understand it.

You can extend the life of your antenna by disconnecting it from your radio when you're not listening. But overall, 500 to 1000 hours spent listening will do in a longwire antenna.

It a joke OK!!!

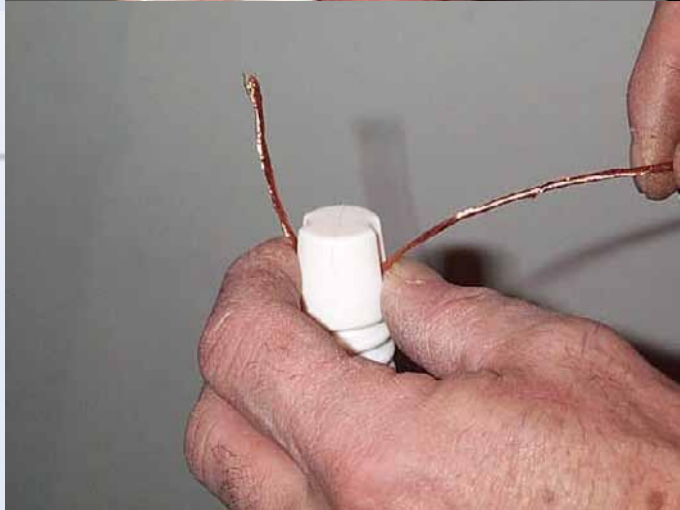
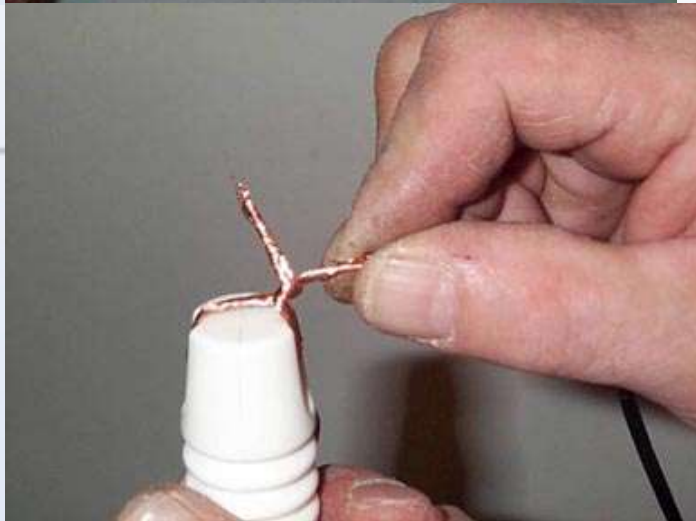

[RETURN TO MAIN PAGE](#)

Remember On A Clear Day You Can Hear Forever

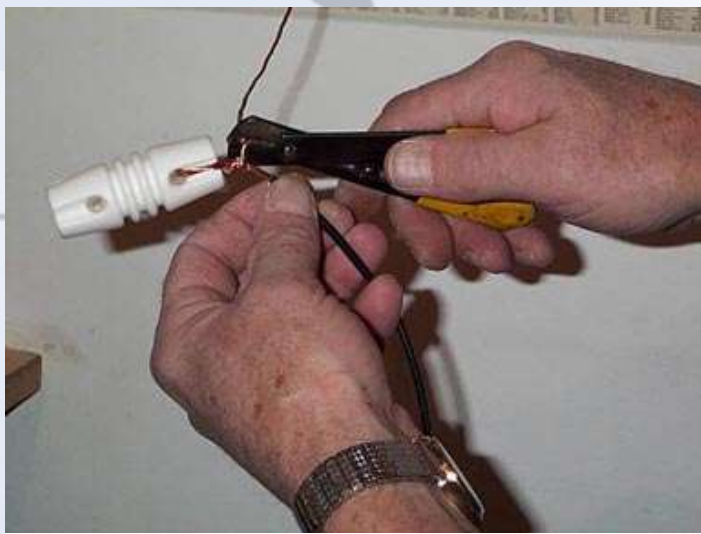

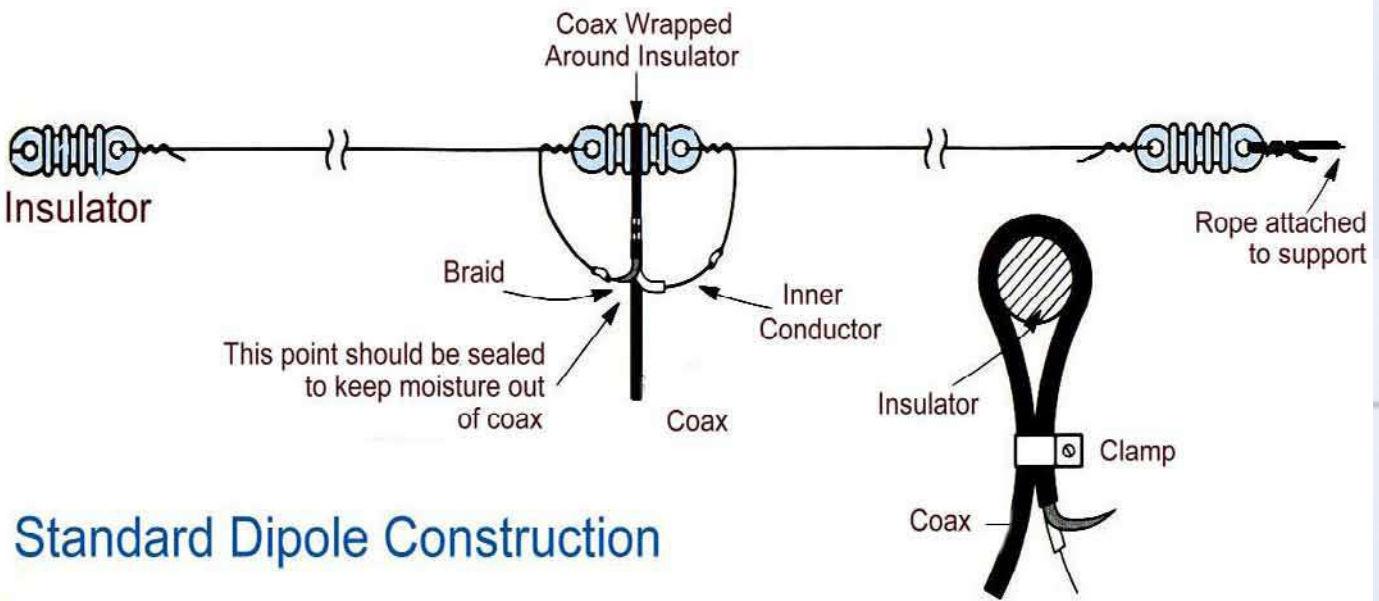
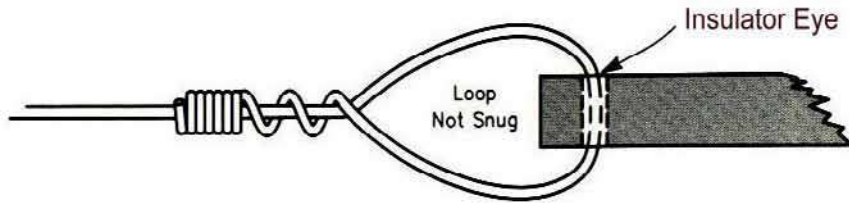

NorthWest Antennas



Standard Dipole Construction

Installing your dipole end insulators.

Dipole links :

How high should by dipole be ?

I hope this information will help.

I wish you the best of luck.

73` Kevin



NorthWest Antennas

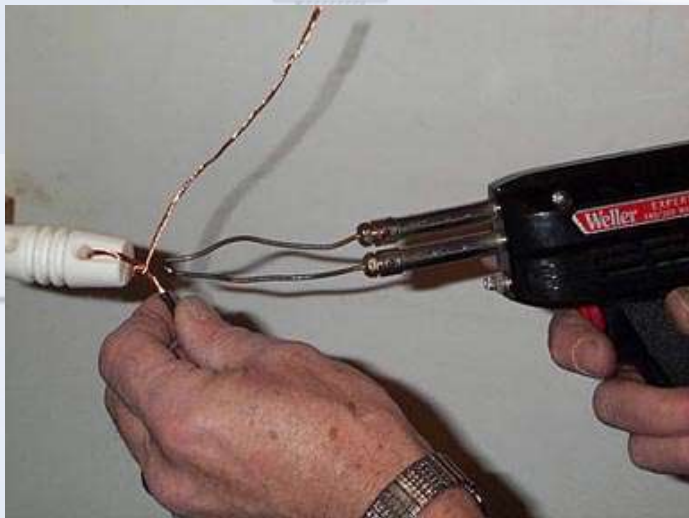

Total Length for Dipole Antennas

| |
|--|
|  <p>Frequency (MHz)</p> |
| <p>Total Length (Ft)</p> |

[NorthWest Antennas](#)

[Home Page](#)

[End insulators installing the fast and easy method here](#)

[Installing lugs/terminals on your coax](#)

[NorthWest Antennas eBay Auctions](#)

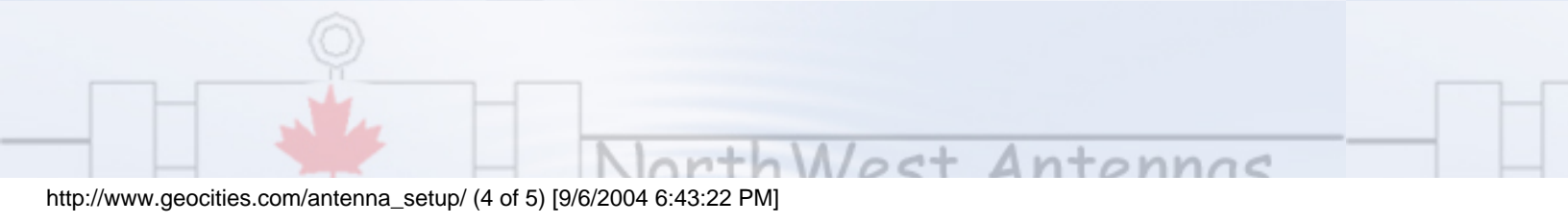

NORTHWEST ANTENNAS



NorthWest Antennas



NorthWest Antennas



NorthWest Antennas

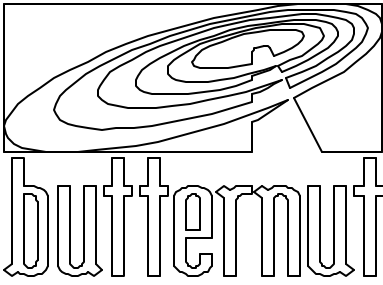

Ground/Radial Systems

GROUND MOUNTING

A vertical antenna in its simplest form, is electrically equivalent to one-half of a dipole antenna stood on end. When the antenna is mounted close to the ground, the earth below takes the place of the "missing" half of the dipole. If ground conductivity is fair to good, a short metal stake or rod may provide a sufficiently good ground connection for resonant and low SWR operation on the bands for which the antenna is designed. This basic arrangement is shown in figure 1.

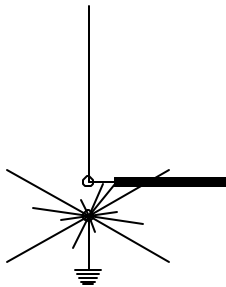
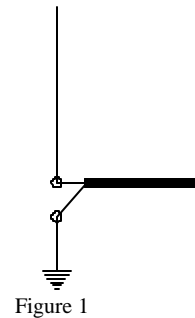

The way it works is that the capacitance between the vertical radiator and the ground causes *return* currents to flow along the earth's surface back to the transmitter. If they have to come back along untreated lossy earth they get back to the source greatly attenuated. This *return* loss is like a resistor in series with the antenna radiation resistance and will therefore affect the feed point impedance. In almost every case the efficiency of a vertical antenna will be greater if radial wires are used to improve ground conductivity as in figure 2. It's important to note that there's no point in cutting radials to any particular length when ground mounting because the earth will detune them anyway. All you want to do is make the surface of the earth around the antenna more conductive than it

is ordinarily.

If you can't copper-plate the backyard, the best approach is to run out as many radials as possible, each as long as possible around the antenna in all directions. Radials may be left on top of the ground however they should be buried for the sake of pedestrians and lawnmowers.

How long should radials be? A good rule is no shorter than the antenna is tall because 50% of your losses will occur in the first 1/4 λ out from the antenna. If you have more than a dozen radials, they must be longer to get the most out of them which is why the FCC specifies 113 wires each .48 λ for AM broadcast stations—the equivalent of a zero-loss ground plane. Obviously, for most ham work this would be overkill.

In some cases wire mesh (i.e. chicken wire) may be used as a substitute for radial wires and/or a ground connection, the mesh or screen acting as one plate of a capacitor to provide coupling to the earth beneath the antenna.

It should be noted that a ground rod is useful only as a d.c. ground or as a tie point for radials. It does little or nothing to reduce ground losses at r.f. regardless of how far it goes into the ground.

Bare wire, insulated, any gauge, it doesn't matter. The current coming back along any one wire won't amount to that much.

EFFICIENCY

The importance of reducing losses in the ground system can be seen from an examination of a vertical antenna's feedpoint impedance which at resonance consists of three components: antenna radiation resistance; conductor loss resistance; and earth loss resistance. An unloaded quarter-wave vertical antenna has a radiation resistance of about 35 ohms with negligible ohmic or conductor loss, but ground loss resistance may be very great if no measures are taken to reduce it, and in some cases ground loss R may even exceed the antenna radiation resistance. These three components may be added together to arrive at the feedpoint **impedance** of a **resonant** (no reactance) antenna. For the sake of illustration, assume that the ground loss beneath a quarter wavelength vertical antenna is 15 ohms, that conductor

loss resistance is zero, and that the radiation resistance is the textbook figure of 35 ohms. The feedpoint impedance would then be $15 + 0 + 35 = 50$ ohms, and the antenna would be perfectly matched to a 50 ohm coaxial line. Since the radiation resistance is an index of the amount of applied power that is consumed as useful radiation rather than simply lost as heat in the earth or in the conductor, the radiation resistance must be kept as high as possible in relation to the total feedpoint impedance for maximum efficiency. Efficiency, expressed as a percentage, may be found by dividing the radiation resistance by the total feedpoint impedance of a resonant antenna, so under the conditions assumed above our vertical antenna would show an efficiency of $35/50 = 70\%$. As a vertical antenna is made progressively shorter than one-quarter wavelength the radiation resistance drops rapidly and conductor losses from the required loading inductors increase. A one-eighth wave inductively loaded vertical would have a radiation resistance of something like 15 ohms and coil losses (or trap losses for multiband antennas) would be in the range of 5 ohms. Assuming the same value of ground loss resistance (15 ohms), the feedpoint impedance would become $15 + 5 + 15 = 35$ ohms and the efficiency would be $15/35 = 43\%$. From the above calculations it is clear that the shorter a vertical antenna must be the less efficient it also must be for a given ground loss resistance. Or to state the matter another way, more elaborate ground or radial systems must be used with shorter verticals for reasonable efficiency. If the ground loss of resistance of 15 ohms from the preceding example could be reduced to zero ohms, it is easy to show that the efficiency of our one-eighth wavelength loaded vertical would increase to 75%. Unfortunately, more than 100 radials each one-half wavelength long would be required for zero ground loss, so lower efficiencies with shorter radials must usually be accepted for the sake of convenience. In spite of their limitations, short vertical antennas over less than ideal ground systems are often more effective DX performers than horizontal dipoles which must be placed well above the earth (especially on the lower bands) to produce any significant radiation at the lower elevation angles. Verticals, on the other hand, are primarily low-angle radiators on all bands.

ABOVE GROUND (ELEVATED) INSTALLATIONS (rooftop, tower, mast. etc.)

The problem of ground loss resistance may be avoided to some extent by mounting a vertical antenna some distance above the earth over an artificial ground plane consisting of resonant (usually 1/4 λ) radial wires. Four resonant radials are considered to provide a very low-loss ground plane system for vertical antennas at base heights of 1/2 λ or more. This arrangement contrasts favorably with the more than 100 radials for zero ohms loss resistance at ground level, and since 1/2 λ is only about thirty-five feet at 20 meters, very worthwhile improvement in vertical antenna performance can be realized, at least on the higher bands, with moderate pole or tower heights. At base heights below 1/2 λ more than four radials will be required to provide a ground plane of significantly greater conductivity than the lossy earth immediately below the antenna: even so, a slightly elevated vertical with relatively few radials may be more effective than a ground-level vertical operating over a larger number of radials if only because the former is apt to be more in the clear. Resonant radial lengths for any band may be calculated from the formula:

$$\text{Length (ft)} = \frac{240}{\text{Frequency (MHz)}}$$

Figure 3 shows the basic ground plane system for elevated verticals. Radials may slope downward as much as 45 degrees without any significant effect on operation or performance. Radials for different bands should be separated as much as possible and the far end of each radial insulated from supporting wires. Figure 4 shows a ground plane system that uses four resonant radials for 40 meters, another set of four for 20 meters, and a third set for 10 meters. A separate set for 15 meters is not ordinarily required because the 40 meter radials operate as resonant 3/4 λ radials on that band. At the lower heights the separate wires of this system may provide enough capacitance to ground to permit low SWR operation on 80/75 meters as well, but it is probable that at least one resonant radial will be required for low SWR on that band. It's important to note that cutting each conductor of rotator cable to a specific frequency will not work unless you separate it, angling each conductor away for most of its length because the longer ones will detune the shorter ones.

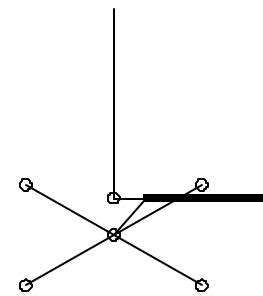

Figure 3

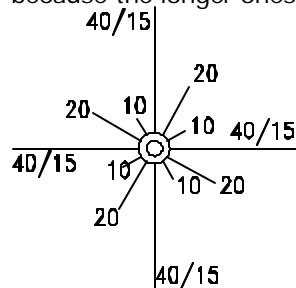

Figure 4

The 12-radial system of Figure 4 is a very good one, but it requires at least 12 tie-off points. Butternut has developed a multiband radial made of 300-ohm ribbon that resonates simultaneously on 40, 20, 15 and 10 meters. Four such radials offer essentially the same ground plane performance as the system of Figure 4 but require only 4 supports. These multiband radials plus additional wire for an 80 meter radial are available separately (our STR-II kit) or as part of the Butternut roof mounting kit (RMK-II).

There are times when physical restrictions will dictate the use of fewer than four radials, and at least one

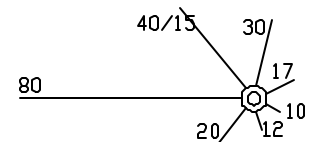

Figure 5

manufacturer recommends 2 radials per band, the radials for each band running 180 degrees away from each other. A simpler (and no doubt less effective) system is shown in Figure 5. Since only one resonant radial is used per band the antenna will radiate both vertically and horizontally polarized energy, and the pattern will not be completely omnidirectional. For true ground plane action and predominantly vertical polarization no fewer than three equally-spaced radials should be used.

Figure 6 illustrates the construction of a multi-band radial which is resonant on 40, 20, 15 and 10 meters. Good quality 300 ohm TV ribbon lead should be used (velocity factor is critical), and the conductors should employ at least one strand of steel wire to support the weight of the radial. Four such radials will be the practical equivalent of the system shown in figure four for operation on 40 through 10 meters.

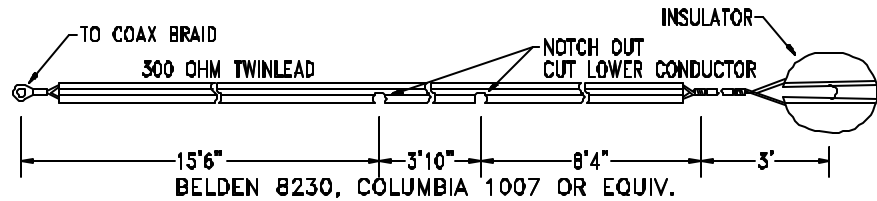

Figure 6

Regardless of the number of radials used in either elevated or ground level systems, all radials should be attached to the ground connection at the antenna feedpoint by the shortest possible leads. An elaborate radial system at ground level, for example, cannot be used with a vertical antenna on a rooftop or on a tall tower, for the length of the ground lead would effectively become part of the antenna, thus detuning the system on most or all bands.

METAL TOWERS AND MASTS

If a metal mast or tower is used to support a vertical antenna all radials should be connected to the mast or tower at the ground connection of the antenna feedline. This is because one of the functions of a resonant radial is to detune a supporting metal structure for antenna currents that might otherwise flow on the structure and thus turn the vertical antenna system into a vertical long wire with unwanted high-angle radiation.

OTHER MOUNTING SCHEMES

In cases where a resonant vertical antenna may neither be ground mounted nor used with an elevated ground plane, operation may still be possible if connection can be made to a large mass of metal that is directly connected or capacitively coupled to the ground, e.g., central air conditioning systems or structural steel frames of apartment buildings. Some amateurs have reported good results with vertical antennas extended horizontally or semi-vertically from metal terraces which serve as the ground connection. Alternatively, a quarterwave vertical may be window mounted if a short ground lead to a cold water pipe or radiator can be used. If a long lead must be used, tuned radials may be required for resonance on one or more bands. Great care should be exercised in such installations to avoid power lines and to keep the antenna from falling onto persons or property.

MOBILE HOME AND RV INSTALLATION

The principles of vertical antenna installations for use on mobile homes or RV's are the same as for other installations, and they all boil down to two main considerations. The first is that of erecting the vertical in the clearest possible spot, away from obstacles (including the MH or RV) that can interfere with radiation from the antenna. The second is that of installing the best possible ground system beneath the antenna in order to minimize losses from r.f. currents flowing in the earth below the antenna. Fortunately, the metal bodies of both MH's and RV's can be used as highly conducting ground planes for vertical antennas in exactly the same way that automobile bodies, etc., provide the ground system for shorter vertical antennas for mobile operation. The metal body of an automobile, MH or RV may be viewed as one plate of a capacitor. Since the surface area of even a small automobile is quite large and in close proximity to the earth, its body is tightly coupled to the earth below and may be considered simply as an extension of the earth itself—a kind of hill as far as radio frequencies are concerned, but one having higher conductivity than the earth itself. RV's and especially MH's, having much greater surface area, will therefore provide a more extensive and effective ground system than a large number of radial wires occupying the same space as the MH or RV.

As in mobile installations, a vertical antenna may be mounted almost anywhere on the body of the vehicle or MH and made to operate with reasonably low VSWR, but it is generally considered that the best possible location for a mobile antenna is in the middle of the roof of the vehicle, i.e., at the center of the vehicle's ground plane and at a point where the antenna will not be in the "shadow" of any part of the vehicle. It is not usually convenient, or even practical to install a relatively tall vertical on the roof of an RV or MH for any number of reasons, so the next best procedure would be to install a vertical antenna with its base at the same level as the roof, preferably near the middle of one of the longer sides.

The exact way in which this may be done is a matter of convenience, but a short mast extending from ground level to the roof of the MH and RV and placed alongside the building or RV would provide a stable and sturdy support with a minimum of mounting brackets and other modifications to the RV or MH. For portable operation such a mast could simply be lashed alongside the RV with the base in a shallow hole in the ground for additional support, and there would be no harm in extending the mast a few inches above the roof level to permit attachment of ropes which could be used to hold the mast firmly against the side of the vehicle and to prevent side sway.

This system has been used successfully with various types of RVs, travel trailers and even passenger automobiles during portable operation. For "L" shaped mobile homes a vertical antenna should be placed in the corner of the "L" so that the metal roof will provide groundplane coverage over 270 degrees.

In all cases the base of the vertical antenna should not be more than a few inches away from the MH or RV so that the shortest possible lead may be run from the ground connection of the antenna to the metal body, as the length of this ground lead will effectively lengthen the antenna itself on all bands, and detuning can occur in some cases. A good electrical connection between the body of the RV or MH and the antenna is important, and in the case of mobile homes it would be a good idea to make sure that good electrical contact exists between the different parts of the metal body. Discontinuities can often lead to the production of harmonic radiation and TVI. The essential circuit connections are shown in the diagram above.

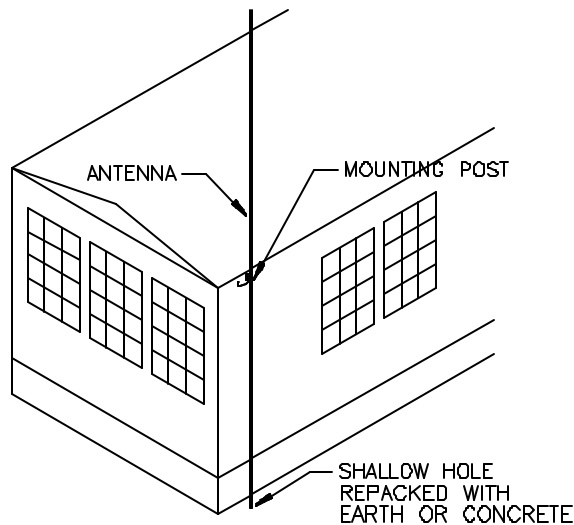
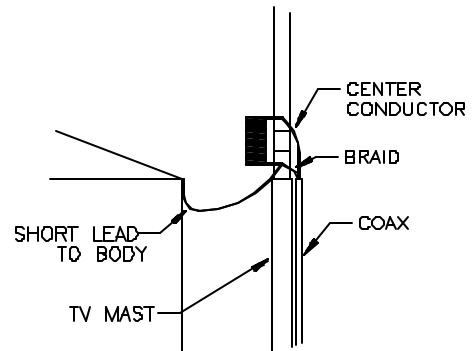

For permanent installations the bottom of the mast may be set deeper in the ground, and concrete may be used for greater strength and stability. The upper portion of the mast should be securely attached to the side of the building. Steel TV mast sections are readily available in lengths of ten feet and the mounting posts of Butternut HF verticals will slide into those which have an outside diameter of 1 1/4 inches and a wall thickness of .058 inches. Other vertical antennas may use different mounting techniques and requirements, so be sure to select a mast that will be suited to the particular situation. The main point to keep in mind is that the mast should not extend more than a few inches above the level of the roof so that the ground lead may be kept short.

LIGHTNING PROTECTION

Modern solid state amateur equipment is particularly vulnerable to damage from lightning or static induced transients that may appear on transmission lines, and conventional air-gap lightning protectors may provide no real protection at all for solid state gear. A line of very effective lightning and static protectors has been developed by ALPHA DELTA COMMUNICATIONS, P.O. Box 571, Centerville, Ohio 45459, for use with solid state equipment, and since these devices feature much faster transient discharge times than earlier designs, they should be investigated for possible use with all vertical and other antenna systems.

Inductors and Loading Coil Current (Mobile and Loaded Antennas)

[[Home](#)] [[Up](#)] [[Independent Measurements](#)] [[Inductor operation](#)]

Related pages:

[Mobile antenna FS comparisons](#) [Loading Inductors](#) [Inductor Spice Model](#)

[W7EL's Measurements and comments](#) [Constructing an RF Current Meter](#)

Much of the data below also applies to inductors in equipment, such as tank circuit.

If you arrived here from a link from K3BU, welcome to W8JI.com I hope you enjoy your visit. If you are not linked here from loading coil current articles on another web site, please skip the blue-text immediately below. It is meaningless.

*If you arrived here from a link from K3BU, I want to apologize for the personal nature of that page and this response. Why is this response necessary? None of us like to see false or out of context claims or personal attack articles. Many of the comments from below were removed from context and quoted to mean something else in another internet article. It is important to read everything **IN CONTEXT**.*

How Does an Inductor or Loading Coil Work?

The most basic answers are:

What does the coil do? A loading coil does not replace a missing fraction of a wavelength. The coil simply inserts a series inductive reactance that cancels capacitive antenna reactance. When a 150 ohm reactance inductor is inserted in series with a 150 ohm capacitive load (like an antenna), only the resistive parts remain.

What determines current distribution in a loading coil? The capacitance to the outside world and the impedance above the loading coil. The current in any inductor would be equal at each end except for displacement currents, which are "imaginary currents" that flow through capacitance.

How much difference is there in loading coil current entering the coil and loading coil current exiting the far end? If the antenna beyond the coil has a low self-impedance compared to the impedance of the shunting capacitance from the coil to "ground", the currents at each end of the coil will be essentially equal. It has NOTHING to do with electrical degrees the coil compensates for. In other words if the portion of antenna above or beyond the loading coil is long or has a large area compared to the physical size of the coil, current is essentially equal throughout the coil.

What does significant current taper in the loading coil indicate? It generally indicates a poor antenna design, where the loading coil (or any other application using an inductor) has high stray capacitance to other areas of the antenna system (like the groundplane) compared to the capacitive reactance of the antenna beyond the inductor. Significant current taper indicates a poor loading coil or poor antenna design.

[click to view typical installation measurements](#)

The Difference Between a Loading Coil and a Normal Inductor

There really isn't any difference, except the location where the coil is used. Mobile loading coils or loading coils for short antennas often have very high reactance. They have small amounts of capacitance at the end, and so stray capacitances are more of a concern. Stray capacitance from turn-to-

turn increases circulating currents and has the effect of increasing inductance and effective resistance at the expense of reducing bandwidth and Q. Stray capacitance to the outside world causes the coil to behave like an L-network, and transform impedances instead of providing a series reactance. This is why the optimum form factor of a coil becomes longer compared to the diameter with any inductor having very high reactance.

Inductors with low reactance are less critical of stray capacitances. Optimum form-factor in a low reactance inductor leans towards a short coil with the diameter nearly equaling length. In tank circuits or loading coils used with longer antennas or with capacitance hats, an optimum inductor is shorter and larger in diameter.

Most optimized inductors fall between 1:1 and 4:1 length to diameter ratios, the exact value depending on the terminating reactances. A coil is a coil, they behave the same way regardless if used as a loading coil or a tank inductor.

Common myths about inductor behavior:

One common myth is loading coil current is reduced as it passes through the coil. There are two reasons cited for this. One idea is the current is reduced because the loading coil replaces a certain amount of "electrical degrees" of antenna area, like the current taper in an antenna. The other idea is that series loss resistance causes a current reduction.

We often find inexperienced builders of 5/8th wl antennas think the "loading coil" needs to contain 1/8th wavelength of wire in order to make a "3/4wl antenna" and thus cause a low feed impedance. In other cases, some claim a half-wave of wire wound on a form causes a 180-degree delay, and is useful for phasing in a collinear array.

The basic flaw is the above ideas do not account for what happens in a coil with mutual coupling between turns. The flawed viewpoint is that current goes in one end, winds its way around through the physical length of wire in the coil, and after a time delay comes out the other end. There is a physical mechanism that prevents this, as we might intuitively think, from actually happening. The mechanism is the magnetic field in the coil!

What Really Happens

When current flows in the transmitter-end of the coil, a magnetic field is created. This magnetic field causes charges in the other turns to instantly move. This effect ripples through the coil at light-speed, just over 186,000 miles per second. As long as the magnetic flux coupling is high, the delay through the coil is the speed of light over the physical length of the coil. The electrical delay is the physical length of expressed the coil expressed in degrees at the operating frequency.

(Another interesting effect occurs. The increasing magnetic field sets up an "opposing voltage" as it cuts across conductors. This opposing voltage, created as the field expands, is what causes the current to rise slower than the applied voltage. If the exciting voltage is decreased the field collapses, and now the voltage changes polarity and aids current flow! If we don't allow the current to flow, the voltage will rise until it does. This is what causes the kick in a relay coil when we open the relay coil path, or the spark in an ignition when the points abruptly open.)

In an RF system, the physical size of the coil actually does add some "antenna effect". For example, on 160 meters the wavelength is about 550 feet. 1.5 feet is about one electrical degree. A skinny one foot tall coil, with negligible stray capacitance, would have about 0.67 electrical degrees phase delay. This delay occurs because to coil occupies a physical length of .67 degrees. Current at each end would be almost perfectly equal, the taper would be about what we would expect for a fractional-degree-long coil.

(In the real world, all components have some stray capacitance and flux leakage, so they have a different amount of electrical length and current taper than the "negligible capacitance" case. In good coil designs, the capacitance and leakage is small and can be ignored. I'll show you measurements later to prove this.)

Now let's look at an extreme case. If the entire antenna is "coil", like a helically wound antenna with no top hat or stinger, current would be reduced to nearly zero at the open end. This is because distributed capacitance over the length of the antenna is fairly high, the shunting capacitance has a low impedance compared to impedance at the end of the antenna, and current is diverted to ground in the form of displacement currents.

Compact loading coils are another matter. In many cases phase delay is negligible or immeasurable by normal methods...flux coupling is nearly perfect. A good example would be a relatively compact toroid or a compact nearly-square L/D ratio loading inductor. I've found it impossible to measure the current taper in a toroid and very difficult to measure in a compact air-core loading coil. (The opposite extreme would be a perfectly straight wire with no folds or bends or the helical antenna described above.)

In the case of the toroid or compact coil, the behavior would be such that doubling the turns nearly perfectly quadruples inductance. If we doubled turns and inductance simply doubled or increased at a much faster rate, we should know the coil is in a mode other than a pure inductor mode. This is a **strong** indicator inductor operating Q is less than optimum, and the inductor might behave less than ideally in critical applications.

As a matter of fact, observing inductance change while adding turns can be an excellent test for flaws or shortfalls in system design. A linear increase in inductance when adding conductor length indicates design problems.

A perfect impedance squaring effect indicates minimal electrical phase-delay, or "antenna length" of an inductor. Impedance squaring as turns are doubled indicates the undesired inductor stray capacitance has a high reactance compared to the antenna system beyond the loading coil. Of course there can be exceptions, but it is a good general rule that large current taper indicates the loading system is much less efficient than necessary.

Making a Delay Line

It's certainly possible to make a delay line from a coil without opposing flux, but doing so requires stray capacitive reactance to be significant compared to the value of distributed inductance in the coil. This would occur in a very long helix, a very large diameter helix or loop, or an inductor near a large metal counterpoise or ground plane.

It's important to remember unless a coil is "stretched out" or "expanded" a great deal, the phase delay will not even be close to the physical conductor length. (The exception could be if you had so much capacitance the inductor acted like a series connected string of L/C/L networks as shown below).

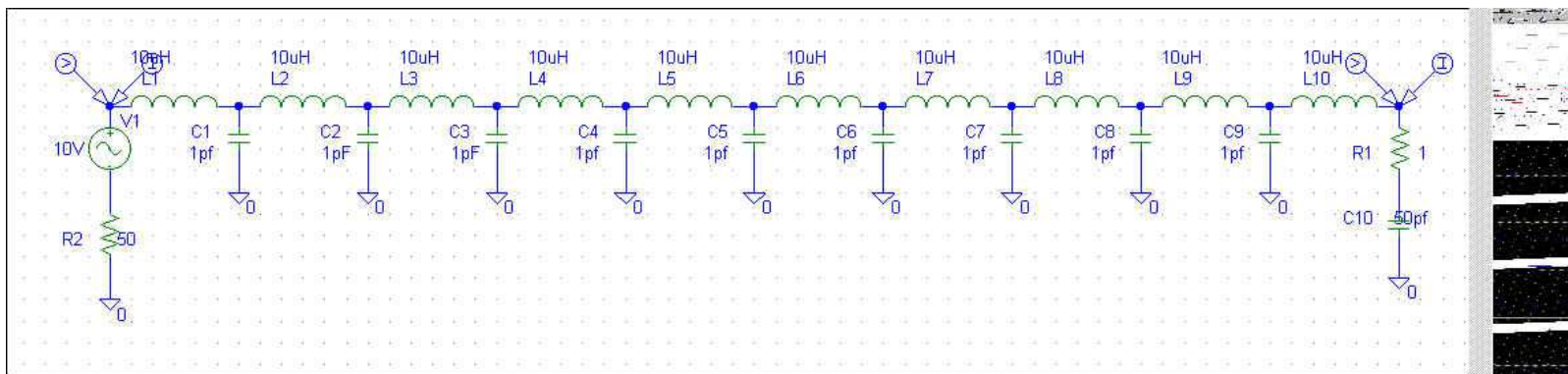

In any case while this effect might be good in a collinear antenna or plate choke (assuming you do it right) it is a BAD effect in a short loaded antenna!

Inductor E/I Phase shift

An inductor delays the flow of current in relationship to applied voltages as the magnetic field inside the coil expands. Voltage increases before current starts to flow. This phase relationship between voltage and current is often confused with time-delay phase in the inductor. Say we have this simple circuit:

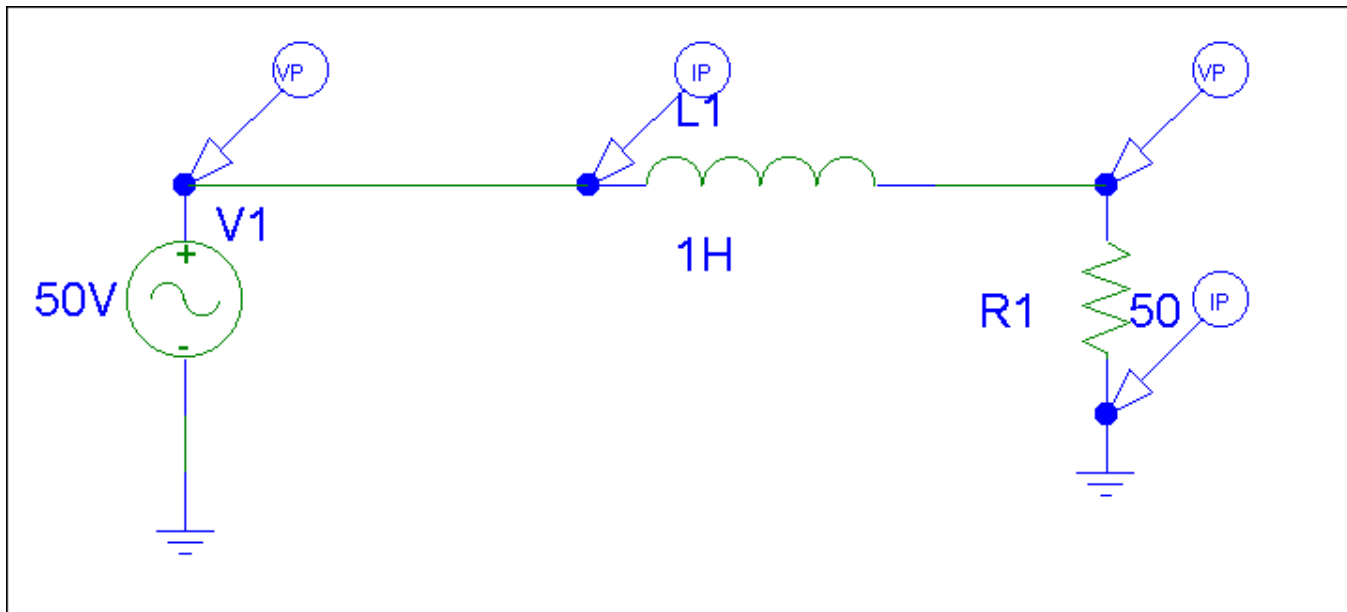

Current and voltage at V1 will be out-of-phase by the effect of L1 "charging" with magnetic flux. Current appears AFTER voltage rises, and falls after voltage falls. Current in R1, however, is exactly in phase with voltage across R1. That's because the voltage across R1 is always $E=I \cdot R$.

Every component must follow the Laws or electrical rules established for that component.

The current in R1 is delayed from VOLTAGE rise in V1 by the voltage to current phase delay of L1. This does result in a time delay in relationship to voltage rise at V1, but there is NO current time delay through L1! V1, L1, and R1 all have the same peak current at the same time!!!

The notion that antenna loading coil delay current by the same time as they delay response to increased voltage is obviously nonsense.

Here is a graph of phase delays in the above system:

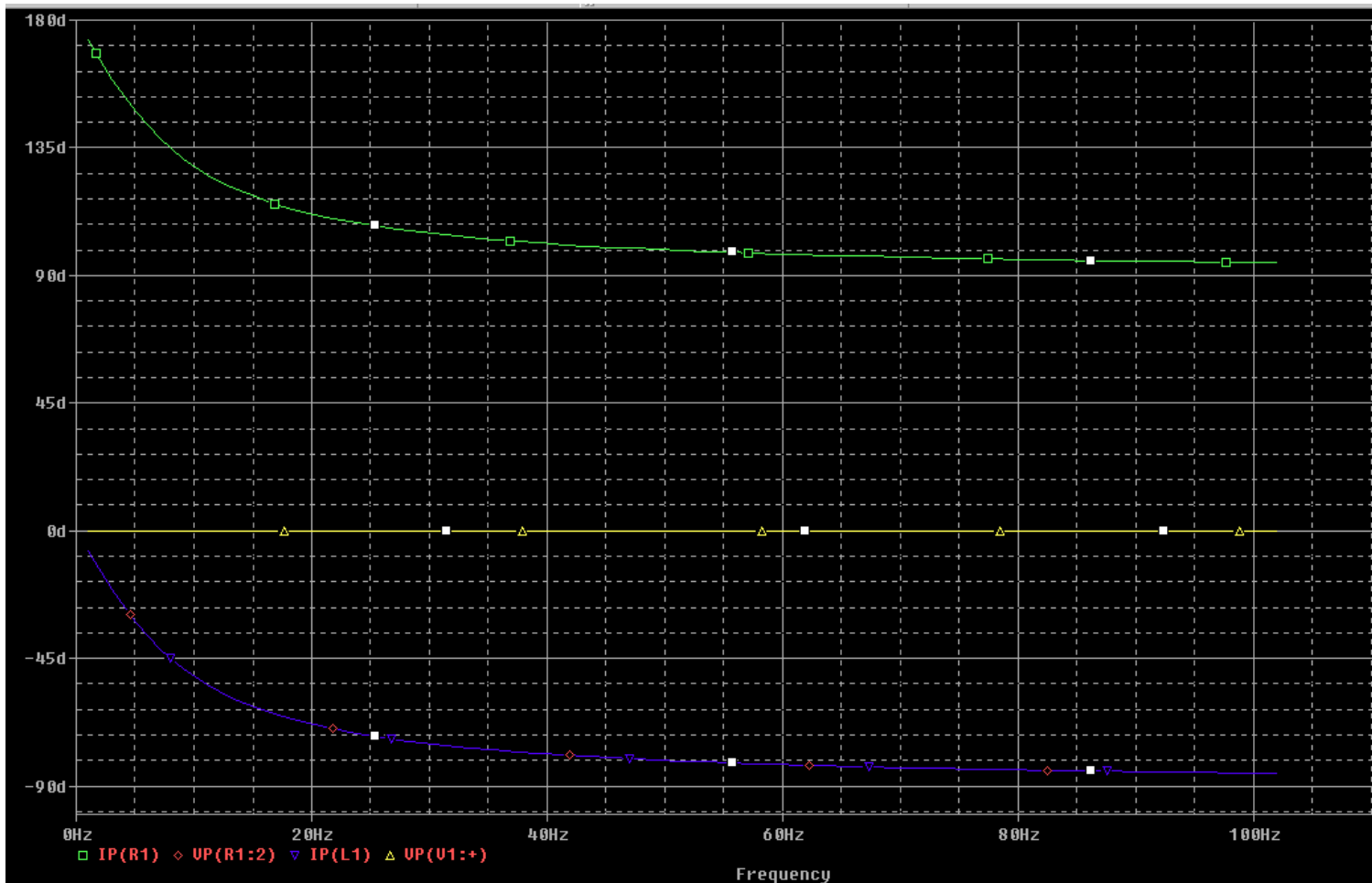

Current in the load, generator, and inductor all exactly track in the same relationship from dc up. There is no "phase delay". The generator voltage is a straight line different than current, and this indicates the generator sees a "reactive load".

The Misplaced Notion

Proponents of the idea that coils replace "antenna length" so far have been unable to define a set of rules or logical reasons why a current reduction and electrical-degree phase delay related to antenna area "replaced" would occur in a two-terminal component. While a long inductor with poor flux linkage from end-to-end or an inductor with low values of stray capacitive reactance to a groundplane compared to series impedance can cause SOME current inequalities or phase delays, the amount is normally immeasurable with normal thermal current meters with a reasonable coil form factor and termination above the coil. The amount of current taper actually rivals the disturbance of the system by adding the measurement device, unless we are very careful in how we construct the measurement device.

Both W7EL and myself made independent measurements that show the fact the coil or inductor is in an antenna has nothing to do with current distribution in the coil. Some people have actually incorrectly reported W7EL's data! Here's what he had to post on rec.radio.amateur.antenna to correct misrepresented claims.

The Need for a Measurement

An article on E-ham claimed measurements proved a new concept about loading coil current. The E-ham article put forth an idea that current disappears as it moves through a loading inductor without a mechanism like displacement currents providing a path. This claim conflicts with established component behavior, so it would indeed be fascinating if it were true! One of the claims supporting the idea that coils in antenna work differently than coils in circuits was that a non-radiating toroid loading inductor showed a current taper when used in an antenna.

I recently **constructed a calibrated current meter** that slips over whip antennas and masts, and is for all practical purposes totally immune to variations in voltage in the system. It also is mostly plastic, and has minimal effect on stray capacitance of the antenna. The resonant frequency and currents are not significantly perturbed by measurements with this meter. When I added a similar meter used in the other tests, resonant frequency shifted significantly! This is a sure sign the meter's capacitance or inductance is affecting the system.

In late December 2003 and early January 2004, I made additional measurements of loading inductor currents. The results clearly agree with the analysis that had been presented on this page since early 2003. Without displacement currents, currents into and out of a loading inductor are equal. That is a hard rule, it agrees with theories defined by people much smarter than me, and I believe it is unbendable unless the works of Faraday, Maxwell, Ohm, and Kirchoff were incorrect.

A sample of measurements above and below the loading coil with various antenna above the coil (current as percent of reference) follow:

| | Toroid with hat | Small 2x2" coil with 24" hat up 24" | Long 12x3" coil with 24" hat up 24" | Long 12x3" coil with 6' whip |
|---------------|-----------------|-------------------------------------|-------------------------------------|------------------------------|
| Current below | 100% | 100 | 100 | 100 |
| Current above | 100 | 94.4 | 73 | 76% |

| | Toroid with whip | long 12x1.5" coil with 6' whip | long 12x1.5" coil with 24" hat | Small 2x2" coil with 6' whip |
|---------------------------------------|------------------|--------------------------------|--------------------------------|------------------------------|
| Current below | 100% | 100 | 100 | 100 |
| Current above coil | 100% | 79% | 75% | 96% |
| Current in whip 1ft above top of coil | | 73% | | |

The most revealing thing was how noticeably small changes in stray capacitance near the middle and top of the loading coil affect current distribution. It was quite evident hanging a large meter on each end of the coil would greatly perturb the system.

Clearly we do NOT want:

- **A large hat just above a large coil**
- **A long large coil and a short whip**
- **A coil near large sheetmetal**

More data along with photographs will appear on a new page over the next month or so. Until then, I can assure everyone the conventional theories presented below are accurate, and the theory that "electrical length" the coil "replaces" is incorrect. Loading coils indeed behave like any other inductor in the world.

Independent measurements by a reliable engineer have agreed with my measurements above. Anyone doubting my data need only read the following [e-mail from W7EL](#).

On to the old text in this page:

The Incorrect Assumption

Another commonly misconception is, since voltage increases at the far end of the loading coil, current must logically decrease. After all, we have a fixed amount of power and voltage has increased. The assumption is:

- 1.) We multiply voltage times current to get power.
- 2.) If voltage increases current must decrease.

Unfortunately, this is *not* correct in reactive systems! Simple P (power) = I (current) times E (voltage) only works when the system is non-reactive. This condition only occurs at resonance, and only below the loading coil at the antenna feedpoint!

In a reactive system, like in a mobile whip above a loading coil, voltage and current are no longer in phase. As a matter of fact, voltage and current can closely approach being 90 degrees out-of-phase when the whip is electrically very short. Since the antenna area above the loading coil is highly reactive (voltage is not in phase with current), we can not multiply voltage times current without considering phase differences.

You may have heard the term "reactive power" or VAR (volt-amperes-reactive). Reactive power is voltage times current without consideration of phase angle. We can have kilowatts of VAR power with only a low power transmitter, and that is what we actually have in the reactive part of the small antenna.

Coil Q and Changes in Efficiency

Current taper or reduction has been cited as a reason coil "Q" has little effect on signal level in mobile systems. Speculation is only the first few turns of the loading coil carry significant current because the coil "leaks" magnetic fields and radiates, and this is why the coil Q has little effect.

Another idea proposes the loading coil "makes up" a certain missing part of the antenna. It goes on to conclude the loading coil can be accounted for in "electrical degrees", making up the "missing difference" in antenna degrees. This isn't true either. The inductor doesn't know where it is and suddenly change from "x" ohms reactance to electrical degrees! It responds to AC currents and voltages as any inductor in any circuit does. It doesn't suddenly change measurement units.

As an example of this, try to define a 45-degree electrical length inductor at 1.8 MHz. That would mean it is a capacitor at 3.61MHz, where it is over 90-degrees long! How many turns at what length and diameter is a 45-degree inductor?? Where is a formula that allows converting a given size inductor to electrical degrees? This shows how useless and meaningless that definition is!

The inductor adds a certain amount of series reactance, that's all. A 300uH inductor is not 20-degrees long, nor is it 80-degrees long, so far as radiation goes unless it is really that long *physically*. It is a certain number of ohms reactance at a certain frequency, or a certain number of units called Henries. It is not "electrical degrees" that it adds, it is a non-dissipative reactance (in combination with a loss resistance because of finite quality) at a certain frequency!

A loading inductor can "insert" a large amount of phase shift, but the phase shift is between voltage and current. The only exception to this would be if the inductor had considerable distributed shunt capacitance to the outside world, and acted like a string of series inductors (with the antenna) and shunt capacitors (shunting to the ground system). In that case we could expect coil Q to be extremely low, since it would be the electrical equivalent of a lossy transmission line. That's either an awful loading coil, or it is a less-efficient helical loaded antenna!

The Correct View

Another group of people don't argue against established and proven circuit theory. They understand charges flowing into one end of the loading coil must have someplace to branch off (a virtual third terminal), or they must flow out the other end. Without that additional "virtual" path, charges flowing into the coil would always equal charges flowing out. This is true regardless of radiation, losses, or induction fields.

This makes perfect sense when we think of any dc circuit, antenna, or RF system. Electrical rules are satisfied, the system behaves as it does in the real world.

There is very little change in current, unless the coil is physically very long compared to the rest of the antenna above the coil or unless the coil is laid right against "grounded" conductors and the whip above the coil is very short. This fits perfectly with helical verticals, where the coil is "stretched out" over the length of the antenna.

It also agrees with base loaded antennas, which have nearly as much current into the antenna above the coil as at the feedpoint. It agrees with center loaded antennas, where current below the coil is essentially uniform and the whip above has triangular distribution.

Current *can* be different in various areas of an inductor, but *only* if shunting capacitances (impedances) to the outside world are significant compared to load capacitance (impedance). Another condition where current can vary substantially is with operation near the condition of self-resonance in what is normally considered or defined as a "series-resonant" mode. This would be a very poor and inefficient loading inductor, such as when a 160-meter antenna is used at a secondary resonant frequency in upper HF.

Circuit Model of a Mobile Antenna

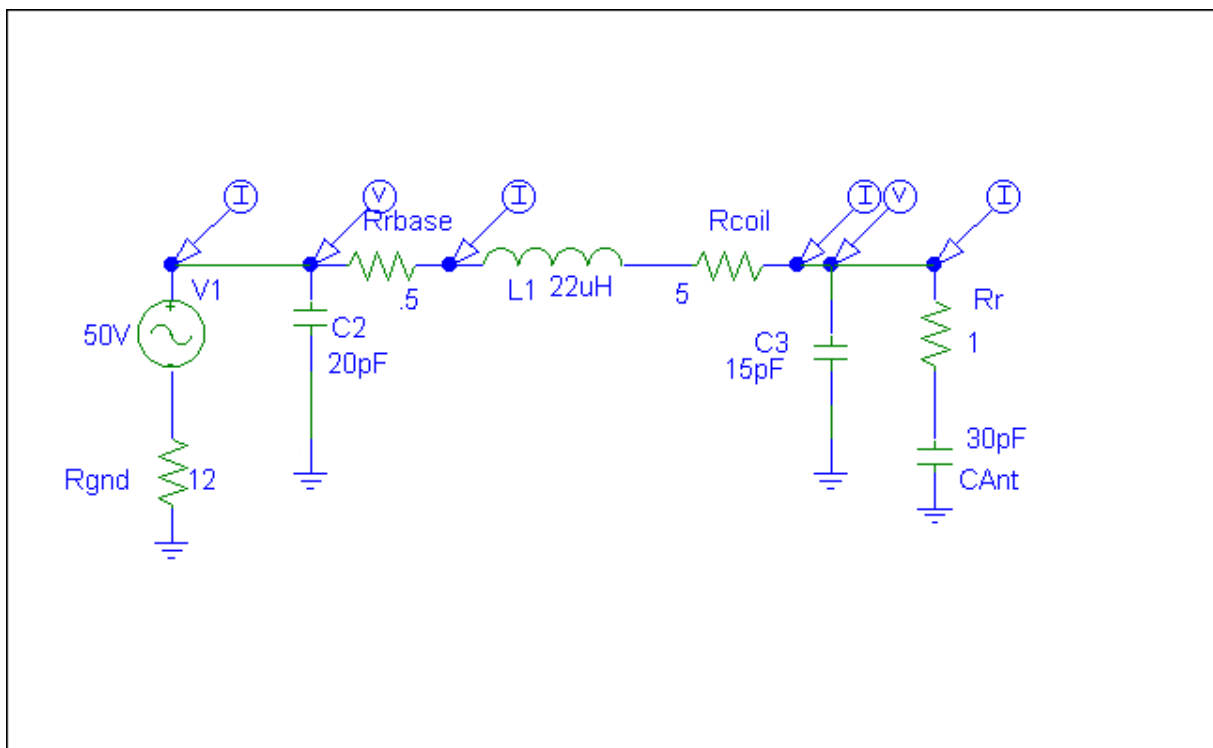

The above model shows what might be a typical mobile antenna installation.

1. Rgnd ground resistance of vehicle normalized to feedpoint
2. V1 coaxial feedline
3. C2 base capacitance
4. Rrbase [Radiation resistance](#) of the base area of the antenna
5. L1 loading coil
6. Rcoil coil equivalent series loss resistance
7. C3 coil shunt C to ground
8. Rr top area [radiation resistance](#)
9. Cant equivalent antenna capacitance above coil area

My 160 Mobile Antenna

I've worked all continents except Africa while 160-meter mobile. I have CW contacts at over 10,000 miles, and SSB as far as Europe (4000 miles). My mobile antenna consists of an eight-foot antenna with a six-foot hat (made from surplus Ford or Chrysler car antennas) at the top. The loading coil is at 5 feet.

This antenna has been on the truck for thousands of miles, without mechanical failure. It is mounted at the upper left corner of the truck bed, about one foot back from the cab.

The following is a model of the current antenna system on my Ford F-250 HD long bed super cab truck:

EZNEC

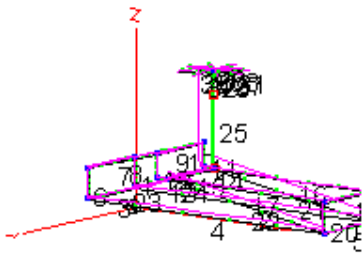

The base impedance in the model is:

Frequency = 1.854 MHz.
Source 1 Voltage = 24 V. at 2.35 deg.
Current = 1 A. at 0.0 deg.
Impedance = 23.98 + J 0.9853 ohms
Power = 23.98 watts
SWR (50 ohm system) = 2.087

Actual measurement at my Johnstonville, GA farm in open flat pastures on August 17 at 8AM. Wet soil 25.8 ohms 0j base impedance, pretty close agreement to EZNEC model and earlier data! (I did have to adjust the model for very low ground conductivity, otherwise the resistance was far too low. It's my belief that NEC-2 underestimates ground losses in small radial or counterpoise systems that are close to earth.) Earlier text shows a base resistance of **28 ohms**, that was dry soil with a slightly different loading coil and antenna.

The modeled current distribution for 1-ampere applied at the base (in 1-foot intervals) is:

- 1ft= 1.0031
- 2 ft= 1.0091
- 3ft= 1.0178
- 4ft= 1.0318
- <Coil>
- 5ft= 1.0175
- 6ft= .97512
- 7ft= .92984
- 8ft = .89522

Measuring the current into and out of the loading coil with a small thermocouple RF meter, I detect no difference This is in close agreement with the model.

The efficiency of this antenna knowing coil Q, radiation resistance, and base resistance calculates just under 1 percent. The model indicates about 1/3 percent efficiency. This is reasonably close.

Removing the hat (in the model only) shows the following changes:

1ft = 1.0043
2ft = 1.0133
3 ft= 1.0279
4 ft= 1.0566

<coil>

5 ft= .95508
6 ft= .72232
7 ft= .27813
8 ft = open

I haven't tested the above, but with the same loading coil loss resistance the model says efficiency is now around 3dB worse. Removing the hat, with NO change in coil resistance, shows nearly loss nearly doubles. Of course the coil resistance would increase, because the loading coil nearly quadruples in size. Bandwidth is less and efficiency is less, even if I could maintain the same coil resistance.

Examples of Unequal Current

In the above models, we see that current into and out of the one-foot long coil is about the same. There is only about **2% change in current** even though the coil occupies 12% of antenna length in the "hat-loaded" antenna, but in fairness I couldn't resolve that change with a reasonably good RF current meter.

The model predicts **10% change in a non-hat antenna**, but I never measured that antenna to confirm it.

Clearly there is no basis to the claim current is high only in the first few turns of an inductor, or that current tapers in relationship to "electrical degrees". The most accurate way to state the effect would be to say: "When the loading coil is short and the capacitance of the antenna beyond the coil is reasonable (in this case 3000 ohms X_c or less), there is an immeasurable reduction in current in the coil. When the required loading reactance is very high (in this case 8000 ohms), the reduction in current is about what we would expect for an equivalent length of antenna replacing the coil."

Degrees Vs Radiation Resistance

This upper four feet of this antenna resonates near 24 MHz with the hat. We can assume it is 90 degrees long at 24 MHz, which would translate to 6.9 degrees on 1.85 MHz. Following that same logic, this would mean the loading coil would be about 83 degrees long electrically. Using the incorrect logic proposed by others where the loading coil "makes up the difference in electrical degrees", there would be almost no current past the loading coil. Obviously this is not the case, the loading coil has very little "electrical length". As a matter of fact, the electrical length is about equivalent to the physical length!

This goes back to radiation theory, and my favorite saying: "Five hundred feet of wire in a one foot long tube is still one foot of antenna". Some CB manufactures sell antennas to consumers with the claim they use 5/8 or 3/4 wavelength of wire in an eight-foot fiberglass whip, so the antenna has more gain. Obviously this is not true. Let's not let such silly claims spread into amateur radio!

Related topics:

[Inductors](#)

The spice inductor model shows one example of how unequal current is created. The model demonstrates a coil having significant distributed capacitance to the point of current return in the system compared to terminating impedance of the coil. In a monopole this return path would be to the groundplane, or anything closer to the potential of the groundplane than the area above the loading coil's position in the antenna system.

Another Practical Antenna Example

Let's assume we have a lossless 15.3 foot long 0.2 inch diameter conductor over a perfect groundplane. Eznec gives the 1.821 MHz base impedance as .3004 -j2169j. In other words, the antenna "looks like" .3004 ohms of load resistance in series with 40.32pF on 1821kHz. The return path for current is through the .3004 ohm resistance and 40.32pF capacitance, back to the ground of the antenna (it is a Marconi antenna).

Such a termination (load) would require a series inductance of 2169j (189.57μH) to cancel feedpoint capacitive reactance. A typical 190μH inductor

would be rather large, requiring somewhere around 53 turns when using a 4" by 4" form factor. One would expect a physically large inductor to have noticeable but very small displacement currents to the groundplane, when the small stray coil capacitance is compared to the 40.32pF termination capacitance. This raises two very important design guidelines:

- *When installing a loading coil of substantial inductance in an electrically short antenna, sheetmetal and dielectrics should be kept away from the coil and areas of antenna above the loading coil. This would include dielectrics on or near the inductor, since the presence of dielectrics would increase undesirable capacitance.*
- *When inductive reactance requirements are large, as when short thin "stingers" without hats are used above a coil, the coil form factor should lean more towards long and thin. Capacitances near the open end of the coil (high voltage end) should be minimized. This would be true even when the coil length increase results in a small reduction in mutual turns coupling, since the stray capacitance may result in a larger loss penalty than the slight increase in accumulated resistance from additional wire length.*

Efficiency

Efficiency in any antenna near earth is almost always dominated by ground related losses, short-height Marconi antennas are no exception. The overall effect of loading inductor Q and matching system losses are "diluted" or "swamped-out" by ground losses. Ground losses cause most systems to have greatly reduced sensitivity to inductor design.

The only consistently predictable factor in efficiency in fractional wavelength Marconi antennas with limited size ground systems is radiation resistance. Efficiency increases almost directly in proportion to radiation resistance.

Radiation Resistance and Power Radiated

[Radiation resistance](#) is probably the most poorly defined term used with antennas. The lack of clear definition creates errors and misjudgments when predicting antenna performance. If you wish more detailed information, this page contains information on radiation resistance. For the purposes of this discussion and to avoid pitfalls associated with using feedpoint impedance as radiation resistance, I'll use the same definitions Jasik, Balmain, and others have used. This definition is based on the IRE definition of radiation resistance being equal to the net or effective current causing radiation squared divided by the power radiated as EM energy, or $R_r = P_r / I^2$.

Using this definition, a folded dipole has a radiation resistance identical to a conventional dipole of the same physical dimensions (~70 ohms).

Radiation is caused by [charge acceleration](#), there is no magic. The only thing affecting radiation resistance in a short vertical antenna near ground is current distribution over the linear area occupied by the radiation portion of the antenna. The general rules are:

Radiation resistance of a Marconi vertical in the maximum possible radiation resistance case for a given height (this is the case where current is uniform throughout the structure) is equal to $1580 \cdot (H/L)^2$ where H equals height and L equals wavelength and both are expressed in the same units. Using degrees, we see a 10-degree tall antenna has a maximum possible radiation resistance of $1580 \cdot (10/360)^2$ or $1580 \cdot .000772 = 1.22$ ohms. This would apply even if the antenna is a vertical, DDRR, Fractal, or folded unipole with considerable top loading.

If current is triangular, radiation resistance would decrease by a factor of four to 0.305 ohms.

Power radiated is given by $I^2 \cdot R_r$

With 100-watts applied to a 10-degree tall antenna, net current in a lossless antenna with uniform current distribution would be 9.05 amperes. With triangular distribution, such as appears in a small diameter short base loaded whip, current would be approximately 18.1 amperes. We are in serious problems if the inductor reduces current along its length, since the only possible way to radiate 100 watts would be to have somewhere around 9 amperes of effective current integrated over the 10-degree vertical area of space for the radiator!

Ground Losses

All current flowing (or displaced) vertically into the antenna must equal current flowing out of the ground or counterpoise system. Even though ground losses are distributed losses, we must normalize all losses to the feedpoint in order to compare systems. There are cases where this will not always occur, causing us to falsely assume we have lower losses than really exist.

In this tutorial and comparison, I have normalized ground losses to the same point where radiation resistance is considered.

System Losses

(Measured data below of actual antenna given below was from 1995 data taken at a different location near Atlanta with a slightly different loading coil and antenna. There is a slight disagreement with current data. I left this all in so you can see the departure from measurements and models using 8 year old data.)

Base Loaded (Triangular Antenna Current Distribution) with no ground loss

Assuming we have a base-loaded antenna, and the operating frequency has a wavelength of 550 feet (around the 160-meter band), a 15.3 foot vertical would fit the above 10-degree value. Interestingly enough when we compare Eznec to formulas available in older (1950 vintage) engineering textbooks, we find radiation resistance predicted by Eznec is .3003 ohms while the triangular current estimate for the same height radiator is .305 ohms! This is an amazing degree of agreement, illustrating what we could do before modeling programs became available. (With perfect top loading, both Eznec and longhand calculations show approximately 1.2 ohms of radiation resistance.)

Assuming our 15.3 foot tall (10-degree) base-loaded antenna uses a coil Q of 200, the coil has 10.845 ohms of ESR. Total resistance with a perfect ground would be $10.85 + .3 = 11.15$ ohms. Current into this system with 100 watts applied would be around 3 amperes, resulting in ~2.7 watts radiated and ~97.3 watts lost as heat in the inductor.

Doubling coil Q (400) would provide 5.73 ohms of base resistance with 4.18 amperes. Power radiated would be 5.2 watts, power lost as heat would be 94.8 watts. Efficiency does not quite double, changing from 2.7 to 5.2%. This results in a 2.8dB change in signal level.

Top Loaded (with no ground loss)

If we added a four-wire hat with 15-foot wires, current would no longer be triangular. While we wouldn't quite reach the optimum uniform distribution, current at the top would be about 78% of current at the antenna base. Feedpoint impedance would become 0.97 -55j, and the antenna would look like 0.97 ohms in series with 159pF.

Using a coil Q of 200, we would now have 2.76 ohms of inductor loss. Current becomes 5.18 amperes. Radiated power is 26 watts, while power lost as heat becomes 74 watts. Even in the perfect ground case, the change in efficiency caused by top loading is large. Top loading (with only the hat) results in 9.8 dB change in signal level when compared to the base loaded case when coil Q remains 200. Efficiency is 26%. The coil remains at ground level for easy matching and frequency change.

In this case current at each terminal of the loading coil would be essentially the same regardless of poor coil mounting techniques. In order to have significant current taper in the coil or in the bottom of the mast, shunt capacitance would have to be a significant compared to 160pF. The antenna's high input capacitance relaxes inductor and antenna mounting electrical requirements.

Base Loaded (high ground loss)

My F-250HD Super Cab pickup truck, when parked over open medium quality pasture land, has a ground resistance of about 20 ohms (normalized to the feedpoint) on 160 meters. Applying this ground loss to the base loaded antenna, the system has a feedpoint resistance of $20 + .3 = 20.3$ ohms. (This is reasonably close to actual feedpoint resistances measured with a similar operating antenna.) Adding coil losses, the system has $20.3 + 10.85 = 31.15$ ohms. (NOTE: Current coil is ~8 ohms ESR, 10.85 ohms is from ~8 year old data) Current is $\sqrt{100/31.15}$ or 1.79 amperes.

This results in .96 watts radiated, and 99.04 watts lost as heat. Efficiency is now around .96%.

Substitution of a coil with a Q of 400 results in 25.7 ohms feed resistance, or 1.97 amperes antenna current at 100 watts. In this case efficiency is now 1.16% for 1.16 watts radiated. The change caused by doubling coil Q with high system ground losses is about 0.8dB, compared to almost 3dB in the perfect ground case! With a poor ground (in this case typical of a very large vehicle), a large change in coil Q produces little change in system efficiency.

Another Top Loaded (high ground loss) System Example (made prior to the EZNEC model above)

Using a large hat isn't practical in a moving mobile, although it could apply to fixed stations suffering with poor ground systems. When the hat is smaller, such as a mobile requires, the loading inductor can be moved higher in the system. Such a move would produce uniform current below the loading coil, with a current shape above the coil dictated by the construction of the upper portion of the antenna. My own mobile uses a six-foot diameter hat manufactured from stainless steel automobile antennas arranged in a spoke. I have no problems with wind or occasional obstructions. While unsightly, a modest hat is workable.

In order to keep the systems comparable I'll use the same radiation resistance provided by a large hat, but intentionally add high ground loss as a lumped resistance. This model ignores field losses near the antenna.

In this case we have 0.97 -55j as the inductor termination presented by the antenna. With ground losses normalized at 20 ohms and an inductor Q of

200, we have $20 + 2.76 + .97 = 23.73$ ohms of feedpoint resistance. Current is 2.05 amperes, and power radiated is 4.1 watts. Power lost is 95.9 watts.

Efficiency is 4.1%, a 6.3dB increase over a base-loaded triangular current system with the same lossy ground. This system is 8dB down from the same "top-loaded" distribution using a perfect ground.

When the system has significant fixed losses, increasing radiation resistance four times by top loading provides a similar dividend in system efficiency. At the same time a substantial increase in coil Q provides only minimal change in field strength.

Current Through Coil

Related pages:

[Inductor spice model](#)

There has been some speculation that current is high only in the first few turns of a loading inductor. Radiation comes solely from charge acceleration or current over spatial (in line) distance.

If any loading inductor shows substantial decrease in current over the length of the inductor, it is an absolute certainty that the inductor is poorly designed and that the system above the loading inductor is not contributing to system efficiency. The reason for this is very simple and straight forward. Any two-terminal component (even considering wire as a "component" applies) MUST have equal charges flowing into and out of each terminal. Voltages to other reference points can be different, but for every charge moving into one terminal a like number of charges MUST move out of the other terminal. Radiation, induction fields, and loss resistances have no influence on this rule.

In order to have any change in current, there must be an additional path or paths for charges. This path can be through leakage resistances, or through fictitious currents called displacement currents. Whatever the path, the total charge movements must be reconcilable. We simply can not have current "disappear".

The normal path upsetting "unbalancing" current into and out of each terminal in an inductor is provided by displacement currents through electric fields. As with any system, the amount of current flow is proportional to potential difference and impedance of the path. In order to shunt a substantial current out of an inductor, the potential difference between the ends of the path has to be high compared to the impedance of the path. The impedance of the stray path must also be reasonably low compared to the normal desired path.

Current diversion is problematic in very large inductors operated at (or very near) internal self resonance, when the self resonance is what we typically refer to as a "series-resonant" condition. This condition is common in plate chokes used in vacuum tube power amplifiers, where the system operates over many octaves of frequency range.

"Series resonances" inside components occur when distributed inductance forms a pair (or multiples of pairs) of "L" networks. The large series inductance from each end of a winding reacts with the small stray capacitance at the center, and forms a very high impedance transformation L network. The electrical potential at the center of the system becomes extremely high, and even the smallest amount of capacitance to surrounding objects will carry a substantial displacement current. The large displacement currents cause the terminal impedances to drop, and allow considerable current to concentrate in small areas of the component. At the same time, considerable voltage can be present. The normal result is arcing or destruction of the component, or failure of the system depending on the choke to operate.

Series resonance always occurs at a frequency higher than the self *parallel* resonant frequency of the component. A loading coil operating under such conditions would be required to have serious design errors to fall into this category, since the end termination capacitances should always be substantially higher than stray capacitance throughout the component. Failure to follow this rule would result in needless loss and reduced SWR bandwidth in an antenna.

The speculation or supposition that the first few turns of a loading coil carry most of the current is clearly untrue. In order to shunt current off, high series impedances would have to exist along with high stray shunting capacitance to areas removed from the radiator. Additionally, the remaining coil area connected to the top area of the antenna above the loading coil would have to present a high impedance to the area where current reduction occurs. This would never be the case, unless the top area of the antenna and loading coil are not resonant near the operating frequency.

A reasonable test for proper inductor and system design would be to remove the antenna above the loading coil, measuring system resonance. If resonance does not change substantially, the area above the coil is not correctly terminating the system. First-order self resonance of the inductor (parallel resonance), when removed from the system, should also be far above the operating frequency of the system. If self-resonance comes within three or four times the operating frequency range, the loading coil almost certainly will have needless performance shortfalls.

Conclusion

A normally functioning inductor has essentially equal currents throughout the inductor, loading coils are no exception. Any current difference requires a substantial current flow through undesired stray capacitances or leakage currents. Neither radiation or induction could change this, it is a basic rule of circuitry.

In a reasonably well-designed system, current into and out of the loading inductor should be substantially equal. Differences in current would indicate excessive and problematic undesired stray capacitance in the loading system design, or measurement errors.

Reduced sensitivity to coil Q is primarily a function of additional losses in the system, not reduction of current through the coil.

This page has had  visits since February 11, 2004.

W8JI.COM

[[Home](#)] [[160 meter History](#)] [[Antennas](#)] [[Amplifiers](#)] [[Amplifier and Radio Relay Sequencing](#)]
[[Balun Test](#)] [[Checking bandwidth with receiver](#)] [[Building a Current Meter](#)]
[[Coaxial line and shielded wires](#)] [[diversity receiver and transmission](#)] [[DX sound files](#)]
[[How to Check Signals](#)] [[Keyclicks](#)] [[MFJ-259B Calibration](#)] [[RF Noise Powerstroke Diesel](#)]
[[My Shack](#)] [[Noise](#)] [[Radiation and Fields](#)] [[Receivers](#)] [[Skin depth and Conductors](#)]
[[stacking broadside collinear](#)] [[Transmitter Splatter](#)] [[Verticals and Baluns](#)] [[W4AN](#)]

[E-ham](#)

[FT1000D Click Mod](#) [FT1000D NB mod](#)

[W4AN Trust Fund. Bill Fisher contributed a great deal to amateur radio. I hope we can give something back to help his family.](#)

Welcome to W8JI's Home Page

Search:



WWW W8JI.COM

All contents of this site are the property of W8JI, but I welcome all links from other sites. Please, if you copy something from here (and even if you rewrite it) add a reference link here! This is entirely to protect technical content, because I refine and update things routinely as errors are called to my attention. Like you, I also learn new things every day. As my knowledge improves, I revise technical articles. I'll note revision dates on articles with changes (if the changes affect technical content).

The most important thing any of us can do to make the web an asset is to help each other with review to insure technical accuracy IMPROVES with time! Let's work to make Internet a reliable source of information instead of a collection of folklore!!

Other Recommended Technical Info Sites:

<http://www.eznec.com/index.shtml>

<http://fermi.la.asu.edu/w9cf/>

<http://www.seed-solutions.com/gregordy/Amateur%20Radio/W8WWV%20Experimentation.htm>

<http://www.ifwtech.co.uk/g3sek/>

QRN USA Lightning Storm Map

For an instant check on USA mainland QRN click on [this link](#) or [this link](#) to a weather map of thunderstorms.

Some of this site's (W8JI.com) contents are listed below:

New Page Cebik Dipole and other short dipoles. Feedline and tuner analysis!!

Amplifiers

SB-221 Tank Voltages and the parasitic oscillation myth. The real explanations behind amplifier parasitic oscillations and alleged damage by HF amplifier parasitic oscillations. Look at voltage throughout the tank at frequencies between 1 and 300MHz, and decide for yourself. Related article at [Arcs](#), what makes an amplifier arc?

Preamplifiers for receiving. Measurements of receiving preamps. Compare your favorite pre-amp (text corrections 4/27/03)

Arcs, what makes an HF amplifier arc? This explains causes of amplifier arcing in any amplifier, including the TL-922 amp, Ameritron amps, [Heathkit SB220 amplifier](#), and any other HF

power amplifier for amateur or commercial service. Simple failures and design or operating shortfalls are often explained as parasitic oscillations

[Bandswitch failures](#) the real causes and cures of bandswitch arcing and failures in HF power amplifiers that are often attributed to poor parasitic suppression causing oscillation

[How to load or tune your HF amplifier](#) and why an amplifier arcs when tuned incorrectly

[Inductors](#) deals with antenna loading coils but also applies to amplifiers

Related page: [Inductor spice model](#)

[Relays](#) how to speed and sequence amplifier T/R relays and how antenna transfer relays affect amplifier failures

[Tank Circuits](#) two models showing tank voltages, currents, loss, and phase shift

[Vacuum Tubes](#) how they work in RF power amplifiers and why vacuum tubes arc in amplifiers Includes details on 3-500Z and 8877 3CX1500 A7 tubes. Learn reasons tubes fail in amps

[Vacuum tubes, how they convert d-c to RF](#) how RF amplifier tubes convert dc to RF power

[VHF Parasitics](#) and general stability. Is your amplifier unstable? If you own a TL922, SB220 series, 30L1, or other amps with grid "negative-feedback" you will want to read this! (rev 5PM Feb23/03) Spice models. The resistor think might be non-inductive might not be what you think. Includes internal photos of various resistors.

[ANTENNAS](#) and antenna related topics

[*New Page Cebik Dipole and other short dipoles.*](#)

[*Feedline and tuner analysis!!*](#)

[EH antenna](#): the E-H and CFA antennas. How they work. See how my early theoretical predictions and descriptions compare to actual field measurements of this most recent antenna theory

hoax! [For measurements click here.](#)

If you think *baluns at the inputs of tuners* are a good idea, go to [this W7EL link](#) and read the section on current baluns. You might be surprised!

Another suggested tuner link is [W9CF](#).

[Balun and Core Selection](#): (mostly receiving) Contains information on core selection for transformers and baluns (it isn't a balun)

[Balun, sleeve baluns](#): How a sleeve balun works and what is important

[Balun, transmitting](#): Testing transmitting baluns and untrue folklore about choke, voltage, and current baluns. Dispelling myth that grabbing coax adequately tests a balun

[Baluns](#): winding methods with toroid cores and debunking myth that a split winding improves performance

[Baluns](#): Common-mode noise. How baluns can help reduce receiving system noise

[BALUN TEST](#): New!!! [Test data on transmitting baluns.](#)

[Beverages](#): Construction, Endfire Beverages, Broadside Beverages, Beverage Arrays for low band DX and other low noise receiving antenna arrays for 160 meters and other low frequency bands. Also see [balun and core selection](#) for Beverage transformers.

[Combiner and Splitters](#): Contains information on Magic-T splitters and combiners, how they work and what they do

[Detuning Towers](#): A tutorial with an important correction of the common error that we adjust for minimum current!! (revised slightly Feb 17, 2003)

[Gain](#). Stacking (Broadside) and end-to-end (Collinear) gain. How it works, dispelling the 3dB myth.

[Loading Inductors](#): A brief tutorial on loading coils (inductors) and inductor Q

Magnetic Loop Antennas: receiving

Mobile and Loaded Antennas: Loading coils, ground losses, and currents in the system. Related page: [Inductor spice model](#)

Power Stroke Diesel RF Noise: PowerStroke Diesel noise and how I corrected the problem in my 2003 F-250

Noise and common mode noise. How it gets into the receiving system [Power line and other noise sources](#)

Omega and Gamma Matching: Contains technical information on Omega and Gamma matches, impedance limits, component selection, component failures

Phasing, Crossfire: Contains information on cross-fire phasing and why cross fire phasing is superior for broad bandwidth low-band receiving arrays

Phasing Systems: A quick discussion of phasing methods

Polarization and diversity: Think you can have the best of the two worlds of vertical and horizontal? Think again!

Radiation and Fields: Electric field, magnetic field, Fresnel zone What the terms we use actually describe

Radiation Resistance: A revised (as of Feb 14, 03) tutorial on radiation resistance and how it is used and misused

Receiving and receiving antenna pages: Relative ranking of antennas for Topband DX plus various articles on low-band DX receiving antennas...including low band receiving antennas such as [Beverage antenna](#) and Beverage antenna construction. Elongated [Loops](#) and other loop receiving antennas such as K9AY, EWE, and flag antennas, small Topband or HF low noise receiving [Verticals](#) , [my receiving antennas](#) (with a demo), [end-fire or cross-fire Beverages](#), [common-mode noise](#) in low noise receiving systems, and more.

Skin depth: The best explanation I have found

Transmitting: Contains information on my various transmitting antennas, including my eight

direction [four-square](#)

[Traps:](#) Measurements and models of traps, including Coaxial and Tribander Antenna traps

[Receivers](#)

[Diversity reception](#) "diversity" receiving using stereo along with some sound file examples

[How I test receivers](#)

[Receiver Tests](#) of some transceivers and receivers. Newly added 756PRO FT1000 MK V Kenwood TS870 (modified)

Receiver IM improvement [mods for FT1000](#) FT1000D

[DX Sound files:](#) What some signals sound like here

[1000MP MK V](#)....mods for FT1000MKV receiver IM and transmitter clicks

[Key Clicks](#)

Includes sound files of signals with excessive bandwidth, a technical description of what causes clicks, and mods for the FT1000(D) and FT1000MP.

[What Causes Clicks](#)....The technical cause and what we can do about clicks.

[Keyclick-MP](#).... An analysis and patch for the FT1000MP 's infamous key clicks

[Keyclicks 1000D](#).... An easy and cheap patch for the FT1000 and FT1000D

[Keyclicks 1000MP MK V](#)....mods for FT1000MKV receiver IM and transmitter clicks

Also see [Radios](#).

[Noise](#)

Technical article about noise and receiving/ receiving antennas

[Power Stroke Diesel RF Noise](#): PowerStroke Diesel noise and how I corrected the problem in my 2003 F-250

[MFJ-1025/1026](#) Technical Information

[Common-Mode Noise](#) issues with feedlines, and how to avoid problems

MFJ-259B Alignment instructions and some technical information [MFJ259B](#).

[MFJ-1025](#) and 1026 phasing unit technical information.

Local ARES activities will be included later. We have a local repeater that covers a good bit of I-75 between Macon and Atlanta. Please give a call on 147.225(+600) if you are passing by.

Special thanks to my friend Bill Fisher, W4AN, who is now a silent key. It was Bill's encouragement and generosity that made this site available.

73,

Tom W8JI

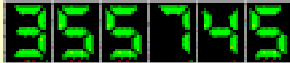
This page has been viewed  times since March 2003. Overall site hits are over 1.5 million for the past year!

©2003,2004 W8JI

NVIS - What It Is and How To Use It

[San Jose](#)[OES](#)[R.A.C.E.S.](#)[History](#)[Frequencies](#)[Contact](#)[Info](#)[Links](#)

By Patricia Gibbons - WA6UBE

NVIS , short for Near Vertical Incident Skywave, utilizes high-angle skywave paths between stations instead of ground-wave or surface-wave in order to communicate via HF radio. NVIS was originally evaluated by U.S. Army Forces in Thailand during the Vietnam conflict in the mid-1960's. It was found that Mobile stations, using whip antennas bent parallel to the ground, could communicate more reliably with their base-stations. Signal strengths would be weaker using high-angle skywave but communications would be more reliable, less subject to fading, and consistent between stations. This was because the intervening terrain was less of an absorber of signals. Terrain obstructions between stations, such as hills, mountainous areas, jungle growth, built-up areas with tall buildings, no longer become path obstructions with stations when NVIS techniques are employed. For distances out to 400 miles between stations, one F-layer hop, at vertical angles of 45 degrees or higher are used. It is not necessary to have high power transmitters. Typical 100 watt power levels are fine. It is necessary that all stations on an NVIS radio network use antennas that are parallel to the ground and the frequencies used are chosen via a radio propagation prediction program in order to have best results.

Frequently asked questions about NVIS:

1: Isn't NVIS, when using a horizontal Dipole antennas, what amateur radio operators always have used? What is so different about it?

ANSWER: NVIS can be viewed more as a "Systems Concept" and not just what antenna to use. The concept of NVIS is to have reliable communications anywhere within an 800 mile diameter circle, in which your station would be located at the center of this circle.

2: What is the advantage of having the antennas close to the ground? I always thought that a radio antenna had to be as high in the air as possible.

ANSWER: Stations communicating via high-angle sky-wave may also be close enough to each other to receive a ground-wave or surface-wave signal. Stations receiving both a sky-wave and ground-wave will have heavily distorted received signals. This will include multi-path distortion because of the extreme difference in the lengths of the two paths. Keeping antennas close to the ground will reduce the generation of a ground-wave signal.

3: Does NVIS work with low-power transmitters??

ANSWER: Yes. In fact, reliable communications between stations are based on three major factors. These can be viewed in triangle form as follows:

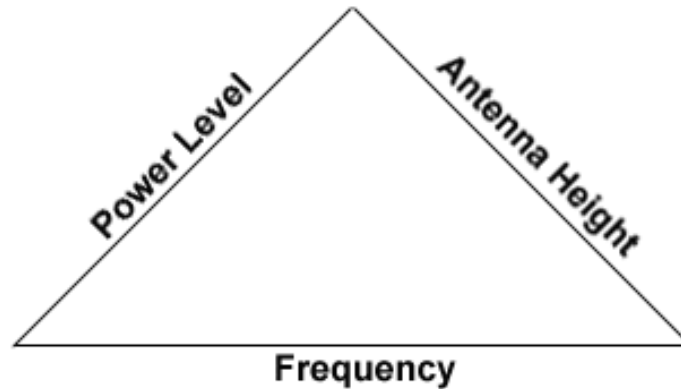

After much research and testing of antennas over the past 5 years, I have determined that the most important leg of the triangle is choice of correct frequency. Specific results will be discussed later on this page.

4: What are the typical frequency ranges used for NVIS?

ANSWER: Usually between 2.0 and 10 Mhz. Exact frequency is dependant on the degree of solar sunspot activity. The best choice of frequency is through the use of a propagation prediction program.

ACTUAL TEST RESULTS

Summer of 1990:

A field test of NVIS was planned between myself and Carl Sato, AA6CF. Carl was located in San Francisco, California. The plan was for my station to run RTTY on the amateur 40 meter band and for Carl to log the field strength of my transmitter at Carl's location. I would try different types of antenna arrangements. The plan was to have a "blind test" in that AA6CF would not know which antenna I would be on at any particular time. My station was parked in a local park in Morgan Hill, California, which is approximately 70 miles from Carl's station in San Francisco. My station was a mobile arrangement consisting of a restored military communications truck and used one of the following three antenna arrangements for the test:

1. 100 Ft horizontal long-wire at six feet above the ground and end-fed with an antenna tuner.
2. 15 foot military whip antenna tuned with an SGC model SG230 "smart-tuner" with the antenna in a vertical position. The base of the vertical antenna was 7 feet off the ground.
3. The same 15 ft military whip antenna but placed in a horizontal position behind the vehicle which allowed the horizontal whip antenna to be 7 feet above, and parallel to the ground.

The amateur 40 meter band was used. The mobile station was set up to transmit 50 watts of "mark-idle" signal. AA6CF would then tell me the signal strength of the signal received as I rapidly changed between one of the three antenna configurations as listed above.

TEST RESULTS:

The received signal strength from AA6CF on each of the three antennas were:

1. Horizontal wire antenna = S9
2. Horizontal Whip antenna = S9
3. Vertical Whip antenna = S8



Fall of 1990:

During the Boy Scout "Jamboree on the Air" (JOTA) event. My communications truck was set up at the San Jose Red Cross facility in their large parking lot.

Antenna Used: 1/2 Wavelength Dipole antenna, center-fed via 6 feet of ladder line and an MFJ-989C antenna tuner. Antenna was spaced 24 inches off the ground on orange traffic cones that were spaced six feet apart. The antenna was free from nearby obstructions as it was located in the center of a large empty parking lot.

Transmitter used: Yaesu FT70/G Paramilitary "Manpack" transceiver

Power used: 10 watts on CW

Frequency used: CW portion of 40 meter amateur band. 7025 - 7150 Khz.

Location of stations worked: All within a radius of 200 miles in the area of San Francisco, Emeryville, Sebastopol, Oroville, Woodland, Sacramento, and Dublin, California.

TEST RESULTS:

All stations reported my signal to be from "S8" to "10 over S9" with exception of one station located in Pleasanton California. The station in Pleasanton was using a Trap Vertical antenna. All other stations reported using horizontal or "Inverted Vee" Dipole antennas.

Spring of 1993:

Purpose of test: To compare two dipole antennas. One at 10-1/2 inches off the ground, and the other at 6 feet off the ground. Ground conditions were chosen to provide a "worst-case" as far as attenuation of the signal due to soil proximity. Soil conditions were extremely wet due to recent rainfall at a local park.

Antenna Used: Two types of antennas:

1. Dipole antenna at 10-1/2 inches off the ground supported by plastic tent stakes.
2. Dipole antenna at 6 feet off the ground and supported by short military telescoping masts.

Both antennas were balanced systems using ladder line from an MFJ989C antenna tuner.

Transmitter used: Yaesu FT70/G paramilitary "Manpack" transceiver

Power used: 10 watts on Single Sideband

Frequency used: Voice portion of 40 meter amateur band. 7225 - 7300 KHz

Location of stations worked: Wanted to find one station within NVIS range but far enough distance not to copy any ground-wave. Station worked was located in Menlo Park, California. This was a distance of 20 miles.

TEST RESULTS:

The station in Menlo Park, California reported my 10Watt PEP signal as:

1. "10 dB over S9" using the dipole antenna that was 6 feet off the ground.
2. "S8" using the dipole antenna that was 10-1/2 inches off the ground.

Post-Test equipment check: The Yaesu FT70/G was checked with a Motorola Model 2410 Communications Service monitor to verify the actual difference in meter indications for an "S" meter reading of "S8" and "10 dB over S9" The actual difference in level was shown to be "15 dB".

"Rules of Thumb" based on the above operations on the 40 meter band:

- A. Assume a half-wave dipole at 1/4 wavelength above ground as a reference for comparison
- B. A half-wave dipole at 6 to 7 feet off the ground will have an attenuation of approximately -4 dB
- C. A half-wave dipole 10-1/2 inches off lossy ground will have a worst-case attenuation of approximately -20 dB
- D. Assuming correct choice of frequency and a 10.7 cm solar flux value in the 200 range, a half-wave dipole at 1/4 wavelength above the ground would provide a 20 dB over S9 signal reading at the

distant station when the transmitter has a power output of 100 Watts.

- E. If the transmitting station uses antenna "B" above, the resultant signal strength would be: 16 dB over S9
- F. If the transmitting station uses antenna "C" above, the resultant signal strength would be: S9

Based on actual documented tests between the station in Menlo Park and my station at the "San Jose Rose Garden" Municipal Park, This data tends to show that the antenna height above ground would not be the prevalent factor in establishing communications. For a 10 Watt radio to receive an "S8" signal report with a half-wave dipole at 10-1/2 inches off the ground on plastic tent stakes, it is apparent that the most important factor is proper choice of operating frequency. The Rose Garden tests were able to be done during a time when our Solar Sunspot activity produced a 10.7 cm solar flux value appropriate for the operating frequency used for this test. As of today's writing of this article (June 29th, 1995) report solar flux indexes are in the low to mid "70's".



Assume the crude drawing as follows:

Ionosphere "F-layer"

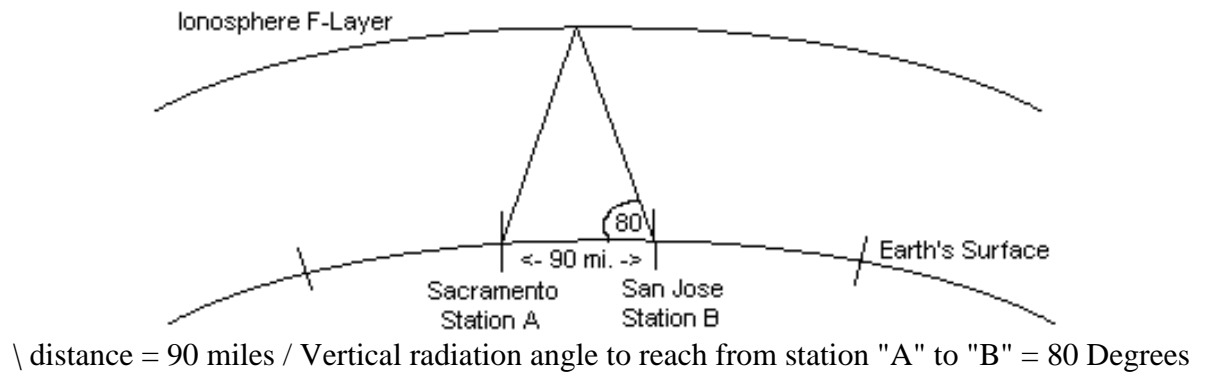

FURTHER COMMENTS ON NVIS:

The U.S. Army did quite a bit of study toward the end of the Vietnam conflict on how to use HF radio more effectively and reliably. This effort was published in issues of "Army Communicator" magazine by Lt. Colonel David Fiedler starting in the early 1980's. Lt. Col Fiedler found that other countries, including German Ground Mechanized units of WWII, and the Soviet Union of today had implemented NVIS. Since the summer of 1990, I have presented the NVIS concept at two west coast ARRL conventions and many local radio club meetings, as a way of publicizing this concept within the amateur radio community. Also, Ed Farmer, AA6ZM wrote a very extensive and well researched article on NVIS in the January 1995 issue of QST Magazine.

As a result of this work, Stanly Harter of the State of California Office of Emergency Services has taken a serious look at the value of HF communications for disaster communications. This is especially valuable for units like our California State Division of Forestry where operations in remote areas not served by the usual VHF and UHF mountain-top repeater sites could impact their ability to communicate effectively. Stanly Harter has also made recommendations for changes in HF antenna designs on their facilities used by State OES in order to effectively utilize the NVIS Concept.

In 1989, Just prior to the Loma Prieta earthquake here in the bay area, I had finished an equipment recommendation for the Director of our GSA-Communications Division with the City of San Jose. Included in the design of the radio equipment to be used by our San Jose Office of Emergency Services was an HF station which emphasized the use of NVIS high-angle skywave so that our center would have both County-wide and also solid, Northern and Central California coverage via HF communications. The Antenna consists of a 55 foot end-fed wire antenna mounted between two radio towers on the roof of our dispatch facility. At the top of one of these towers is an SGC "Smart-Tuner" which can then tune this horizontal wire on any frequency from 1.6 to 30 Mhz. The HF Radio used is a model RF3200 made by Harris/RF Communications Group. This HF station meets Part 90 rules for commercial type acceptance, and also covers any frequency from 1.6 to 30 Mhz. In an emergency, this station is capable of communications with State of California's Office of Emergency Services over their "Operation Secure" HF radio system.



Dr. Earl Stevens, Our Chief Radio Officer has his hand pointed to the ground to show relative scale.



Completed dipole antenna feed with ladder line installed 10 inches off the ground on plastic tent stakes.



10infeed shows the manner of connecting the antenna system to 3/4 inch ladder-line by the use of dual-banana plugs.

RACES contact: [Dave Pratt](#)

Webmaster: webmaster@ci.sj.ca.us

NVIS: Near Vertical Incidence Skywave

[What is NVIS?](#)

[What are the advantages and disadvantages of NVIS?](#)

[What kind of antenna works well for NVIS?](#)

[How do I select a frequency for NVIS operation?](#)

[NVIS related links](#)

What is NVIS?

NVIS, or Near Vertical Incidence Skywave, refers to a radio propagation mode which involves the use of antennas with a very high radiation angle, approaching or reaching 90 degrees (straight up), along with selection of an appropriate frequency below the critical frequency, to establish reliable communications over a radius of 0-200 miles or so, give or take 100 miles. Although not all radio amateurs have heard the term NVIS, many have used that mode when making nearby contacts on 160 meters or 80 meters at night, or 80 meters or 40 meters during the day. They may have thought of these nearby contacts as necessarily involving the use of groundwave propagation, but many such contacts involve no groundwave signal at all, or, if the groundwave signal is involved, it may hinder, instead of help. Deliberate exploitation of NVIS is best achieved using antenna installations which achieve some balance between minimizing groundwave (low takeoff angle) radiation, and maximizing near vertical incidence skywave (very high takeoff angle) radiation.

As hams, we often faithfully follow the advice: get your antenna up as high as you can get it! We do this, and other things (like choosing antennas that have a low angle of radiation) in order to maximize the distance over which we can communicate. An antenna with a particularly high angle of radiation is often somewhat disparagingly referred to as a "cloudwarmer", the implication being that if the signal isn't radiated at a low enough angle, it's being wasted. For NVIS, we ignore all this traditional advice, and select instead techniques which will maximize not our DX, but our ability to reliably communicate with other stations within a radius of 0-300 miles.

Not just any old frequency will work for NVIS. Successful NVIS work depends on being able to select, or find (through trial and error), a frequency which will be reflected from the ionosphere even when the angle of radiation is nearly vertical. These frequencies usually are in the range of 2-10 MHz, though sometimes the limit is higher. The trick is to select a frequency which is below the current critical frequency (the highest frequency which the F layer will reflect at a maximum--90 degree--angle of incidence) but not so far below the critical frequency that the D and/or E layers mess things up too much.

Note: If you're already familiar with the ionosphere's role in HF radio communications, you may want to [skip to the explanation of what's special about NVIS.](#)

There are two main types of propagation at HF, known as "groundwave" and "skywave". Groundwave

propagation occurs when the receiving station is sufficiently close to the transmitting station, and is able to receive the portion of the transmitting station's signal which clings to the ground. The range of groundwave propagation varies with the type of antenna at the transmitting station, the characteristics of the ground between the transmitting station and the receiving station, and other factors. It can be anywhere from a few miles, to a few dozen miles. Distances beyond the range of the groundwave signal are covered by skywaves. Skywaves are the waves which radiate upward at some angle from the antenna, and (we hope) are reflected from the ionosphere, to return to earth further away.

The ionosphere is a high altitude region of the Earth's atmosphere which is composed of gaseous atoms which have broken into ions. The sun is the source of the ionizing energy, so the condition of the ionosphere varies with time of day, season of the year, the 11-year sunspot cycle, and the 27-day rotation of the sun. The layers of the atmosphere that effect radio propagation are the D, E, and F layers. I won't go into much detail in outlining their roles. If you're interested in this topic, entire books have been devoted to it. In a nutshell, it's the F layer which is usually involved in reflecting our signals back to earth, while the D layer absorbs our signals. The E-layer can either help, or hinder.

Long distance propagation of radio waves is usually achieved by their being reflected from the ionosphere, and returning to earth some distance away from their point or origin. (Follow along with [the diagram](#) if you wish.) Radio waves which have been radiated at a very low angle of radiation travel a long way before finally making it up to the ionosphere, strike the ionosphere at a very shallow angle (A) and return to earth far away from their point of origin (A'). As the angle of radiation goes up, the radio waves strike the atmosphere at a more moderate angle (B), and return to earth closer to their point of origin (B'). For any given frequency and current state of the ionosphere, there may be some maximum angle of incidence at which the ionosphere will reflect signals back to earth. Signals which strike the ionosphere at a higher angle of incidence than the current maximum will not be reflected at all, but will continue on out into space, instead (C). The area of the earth to which the reflection would have occurred will be in what we call the "skip zone" (unless it's close enough to the signal source to receive the groundwave signal). The skip zone is the region consisting of areas of the earth's surface which are outside the radius the transmitting station's groundwave will reach, and yet not far enough away to receive reflections of skywaves.

NVIS techniques concentrate on the areas which are often in the skip zone. The idea is to radiate a signal at a frequency which is below the critical frequency, at a nearly vertical angle, and have that signal reflected from the ionosphere at a very high angle of incidence, returning to the earth at a relatively nearby location. (See [illustration](#).) Of course, no antenna radiates all its signal at exactly one angle, so the best we can get is a range of angles, ranging from perfectly vertical, to nearly vertical. The portion of the signal which is radiated at a vertical, or nearly vertical, angle reflects back to earth over some radius, which is determined by the lowest angle at which the antenna radiates much signal. Absorption by the D layer, and other factors, determine some minimum frequency below which the signal will no longer be usable, and usually some distance beyond which signals will no longer be usable.

For areas which are within the groundwave range of the transmitting station, the groundwave's presence

may interfere with the reflecting skywave. It may very well help, too. It all depends on whether the groundwave and the skywave arrive in phase, out of phase, or somewhere in between, and their relative strengths. If the groundwave arrives at about the same strength as the skywave, and the two are out of phase, the signal will disappear. Since the height of the ionosphere varies with time, phase alignment may drift from in phase, to out of phase, resulting in signal fading. For this reason, it's best to minimize groundwave radiation when using NVIS techniques, so that it will be less likely to interfere with the skywave.

Although this discussion has focussed mainly on the transmission of signals, there is a corresponding advantage of using NVIS techniques in reception, and a trick or two that are useful mainly for reception. The corresponding advantage is that if your antenna favors high angles for transmission, it will also favor high angles for reception. An antenna optimized for radiating at the high angles used for NVIS will also be optimized for receiving the skywaves which will be arriving at a high angle from the ionosphere. An antenna which does not radiate much groundwave signal will also probably not receive groundwave signals as strongly. When both stations are using antennas which are optimized for NVIS, the mode is favored both in transmission and reception, and those advantages add together, increasing the chances of reliable communication.

There is also an advantage inherent in the use of NVIS style antennas which applies only to receiving. The frequencies which are useful for NVIS (usually 2-10 MHz) are the same frequencies which are most susceptible to atmospheric noise. A major source of atmospheric noise is distant thunderstorms. Nearby thunderstorms are the worst, of course, but the noise from all possible sources adds together. Unless there is a nearby thunderstorm, most noise will be the sum of the noise from distant sources which are all propagated to the receiving antenna. Since an antenna optimized for NVIS is listening mostly to signals propagated from relatively nearby areas, and does not favor the reception of signals, static crashes, and other sources of noise and interference from more distant sources, it will not hear as much noise or interference as an antenna optimized for DX operation. The result is a better signal/noise ratio.

Often, taking measures which optimize a station's NVIS capabilities will drop the noise level substantially. Sometimes, the drop in noise can be maximized at the expense of some signal strength, and result in a communication circuit which has lower signal levels, but even more dramatically lower noise levels, for an even better signal/noise ratio than could be achieved by focusing only on maximizing signal levels.

So, selecting a frequency below the critical frequency, but not too far below it, and selecting an antenna which will radiate skywaves at a high angle, and minimize groundwaves and the reception of noise, are the essential tricks of establishing reliable communication in the 0-200 mile radius which is so often a challenge for HF operation.

What are the advantages and disadvantages of NVIS?

Among the many advantages of NVIS are:

- NVIS covers the area which is normally in the skip zone, that is, which is normally too far away to receive groundwave signals, but not yet far enough away to receive skywaves reflected from the ionosphere.
- NVIS requires no infrastructure such as repeaters or satellites. Two stations employing NVIS techniques can establish reliable communications without the support of any third party.
- Pure NVIS propagation is relatively free from fading.
- Antennas optimized for NVIS are usually low. Simple dipoles work very well. A good NVIS antenna can be erected easily, in a short amount of time, by a small team (or just one person).
- Low areas and valleys are no problem for NVIS propagation.
- The path to and from the ionosphere is short and direct, resulting in lower path losses due to factors such as absorption by the D layer.
- NVIS techniques can dramatically reduce noise and interference, resulting in an improved signal/noise ratio.
- With its improved signal/noise ratio and low path loss, NVIS works well with low power.

Disadvantages of NVIS operation include:

- For best results, both stations should be optimized for NVIS operation. If one station's antenna emphasizes groundwave propagation, while another's emphasizes NVIS propagation, the results may be poor. Some stations do have antennas which are good for NVIS (such as relatively low dipoles) but many do not.
- NVIS doesn't work on all HF frequencies. Care must be exercised to pick an appropriate frequency, and the frequencies which are best for NVIS are the frequencies where atmospheric noise is a problem, antenna lengths are long, and bandwidths are relatively small for digital transmissions.
- Due to differences between daytime and nighttime propagation, a minimum of two different frequencies must be used to ensure reliable around-the-clock communications.

What kind of antenna works well for NVIS?

Dipole

Once again, the dependable dipole antenna proves itself useful. One of the most effective antennas for NVIS is a dipole positioned from .1 to .25 wavelengths (or lower) above ground. When a dipole is brought very close to ground, some interesting things happen. The most interesting thing, from an NVIS perspective, is that the angle of radiation goes up. In the range of .1 to .25 wavelengths above ground, vertical and nearly vertical radiation reaches a maximum, at the expense of lower angle radiation (which we'd like to minimize, anyway, for NVIS). A dipole can be used at even lower heights, resulting in some loss of vertical gain, but often, a more substantial reduction in noise and interference from distant regions. Heights of 5 to 10 feet above ground are not unusual for NVIS setups, and some people use dipoles as low as two feet high with good results (relatively weak signals, but a very low noise floor).

Another interesting thing that happens with very low dipoles is that their feedpoint impedance goes

down. An acceptable SWR with 50 ohm coax is likely. Plan to bring your tuner along just in case, but you may get by just fine without it.

Yet another fortunate thing about low dipoles is that they are easily erected. Finding a tree which will serve as a support is often easy, and it's not hard to get a line in a branch which will suffice. Masts made of PVC tubing are practical at these heights. Very low dipoles can be supported by traffic cones with a notch cut in the top, or a simple tripod made from short sections of PVC pipe or wooden dowels, and bungee cords.

With the exception of the very lowest dipoles, most dipoles will gain an extra 2 db or so of vertical gain if you allow the center to droop a few feet. Allowing the center to droop means that the end supports don't have to be as sturdy, which makes installing a good NVIS dipole that much easier.

Inverted Vee

The dipole's close cousin, the inverted vee, is another good NVIS antenna, which can be even simpler to support. An inverted vee will work almost as well as a dipole suspended from a slightly lower height than the apex of the inverted vee, so long as the apex angle is kept gentle--about 120 degrees or greater. An inverted vee is often easier to erect than a dipole, since it requires only one support above ground level, in the center.

Counterpoises

The high angle radiation of a dipole (or inverted vee) can be enhanced by adding a counterpoise wire below it, about 5% longer than the main radiating element, to act as a reflector. The optimum height for such a counterpoise is about .15 wavelengths below the main radiating element, but when the antenna is too low to allow for that, a counterpoise laid on the ground below the antenna is still effective.

A knife switch at the center point of the counterpoise can be used to effectively eliminate the counterpoise from the antenna system. This technique is useful for using a dipole for NVIS and longer distances, too. A counterpoise is installed at ground level, or as high as the switch can easily be reached, and a dipole is mounted .15 wavelengths above the counterpoise. When the switch is closed, the vertical gain will increase, and the noise levels will drop. When the switch is open, lower angle gain will increase, improving the antenna's performance for non-NVIS use.

How do I select a frequency for NVIS operation?

The selection of a optimum frequency for NVIS operation depends upon many variables. Among the many variables are time of day, time of year, sunspot activity, type of antenna used, atmospheric noise, and atmospheric absorption. To select a frequency to try, one may use recent experience on the air, trial and error (with some sort of coordination scheme agreed upon in advance), propagation prediction software, [near real-time propagation charts](#) (available on the Internet) showing current critical frequency,

or even just a good educated guess. Whatever the strategy used for frequency selection, it would probably be best to be prepared with some sort of "Plan B" involving communicating through alternate channels, or following some pre-arranged scheme for trying all available frequency choices in a scheduled pattern of some sort.

In this discussion, some of my comments will assume that the reader's choice of frequencies is restricted to the amateur bands, but much of the discussion will be more general.

NVIS related links

<http://www.ci.san-jose.ca.us/oes/races/hfradio.htm>

<http://www.gordon.army.mil/acd/tcs/hf/2418xtr2.htm>

http://www.wr6wr.com/products/book_nvis.html



Instructions

Model HF6V

WARNING: DO NOT INSTALL THE ANTENNA WHERE ANY PART OF IT CAN COME INTO CONTACT WITH POWER LINES IN THE EVENT OF STRUCTURAL FAILURE, DURING INSTALLATION OR IN THE COURSE OF NORMAL FLEXING AFTER INSTALLATION FOR SUCH CONTACT CAN RESULT IN DAMAGE TO PROPERTY, BODILY INJURY OR EVEN DEATH!

WARNING: IN NO CASE SHOULD THE ANTENNA BE INSTALLED WHERE STRUCTURAL FAILURE OF ANY PART OF THE ANTENNA OR ITS SUPPORTING SYSTEM CAN ENDANGER PERSONS OR PROPERTY.

CAUTION! A GROUNDED ANTENNA WILL BE AT D.C. GROUND POTENTIAL! TO AVOID THE DANGER OF SHOCK CONNECT ALL STATION EQUIPMENT TO A GOOD EARTH GROUND. IT IS ALSO RECOMMENDED THAT ALL STATION EQUIPMENT BE DISCONNECTED FROM THE POWER MAINS BEFORE CONNECTING THE FEEDLINE TO THE ANTENNA. PLEASE CONSULT THE A.R.R.L HANDBOOK OR OTHER REFERENCE MANUALS FOR ADDITIONAL SAFETY PROCEDURES WHEN WORKING WITH ELECTRICAL EQUIPMENT.

NOTE: PLEASE READ ALL INSTRUCTIONS THOROUGHLY BEFORE PROCEEDING TO ASSEMBLY.

NOTE: HIGH PERFORMANCE BUTTERNUT VERTICAL ANTENNAS REQUIRE A RADIAL SYSTEM FOR ALL INSTALLATIONS.

Butternut offers three systems for installing vertical antennas:

- Model GRK Ground Radial Kit for ground mounting—160 thru 6 meter operation
- Model RMK-II Roof Mounting Kit for roof mounting—80 thru 6 meter operation
- Model CPK Capacitive Counterpoise Kit for compact installations below 25 ft (7.6 m) above the earth—80 thru 6 meter operation

Please refer to TECH NOTES—GROUND/RADIAL SYSTEMS, at the end of this instruction, for other mounting schemes and assistance in designing your own radial system.

REQUIRED TOOLS

Flat blade screwdriver and pliers. A 1/4", 11/32" and 3/8" nut driver will be helpful.

ASSEMBLY

Refer to the appropriate diagrams and proceed as follows:

1. Check to be sure that all parts are present.
2. Install tube w/insulator (A) per instructions packaged with mounting system or Tech Notes Ground/Radial Systems.

NOTE: A small packet of anti-seize/anti-oxide compound (Butter-It's-Not™) will be found inside tube w/insulator (A). This compound should be applied lightly to each tubing joint and to the inside of all clamps that must make good electrical contact with the tubing sections.

3. Locate tube (B) and tube (B1). Slide the insulator end of tube (B1) into the end of tube (B) with hole located 1/4 in (6.4 mm) from the end of the tube. Pass a # 8 x 1 1/2" screw through both parts and secure with a lock washer and hex nut.
4. From the center of the insulator, measure downward to a point that is 13 in (33 cm) along tube (B) and make a pencil mark.
5. From the center of the insulator, measure upward to a point that is 9 3/8" (23.8 cm) along tube (B1) and make a pencil mark.
6. Locate coil assembly 80/40 meter (C) and slide the clamp at the outer end of the larger 80 meter coil over tube (B1), lowering the entire assembly until the middle clamp can be positioned around the insulator between tube (B) and tube (B1).

NOTE: The middle clamp may have to be pulled open slightly to pass the bolt that goes through tube (B1) and the insulator.

7. Position the center coil clamp of coil assembly 80/40 meter (C) in the center of the insulator between tube (B) and tube (B1). Pass a #10 x 1" screw through the clamp as shown. Secure with a flat washer, lock washer and wing nut.

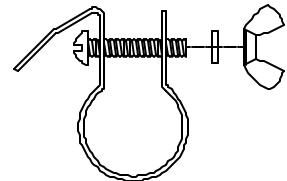

NOTE: The outer tab of this clamp may be bent back slightly to provide clearance for the bolt, bending it back into place after assembly.

8. Stretch the 40 meter (smaller) coil on the coil assembly 80/40 meter (C) until the top of the upper clamp is even with the upper mark. Secure with a #10 flat washer, lock washer and wing nut.

ASSEMBLY

9. Stretch the 80 meter (larger) coil on the coil assembly 80/40 meter (C) until the bottom of the lower clamp is even with the lower mark. Secure with a #10 flat washer, lock washer and wing nut.
 10. Locate the capacitor assembly 80/40 meter (D) and install capacitor bracket 80 meter (D1) on the larger 200 pF capacitor using the installed screw.
- NOTE: DO NOT USE EXCESSIVE FORCE OR OVER TIGHTEN THE SCREWS ON EITHER CAPACITOR AS YOU WILL DAMAGE THEM. DO NOT DROP THIS ASSEMBLY AS YOU MAY FRACTURE THE CAPACITOR'S CERAMIC SHELL.**
11. Locate capacitor bracket 40 meter (D2) and install on the smaller 67 pF capacitor as above.
 12. Install the above assembly onto the #10 screw protruding from the tab of the center clamp on the coil assembly 80/40 meter (C). Align capacitor bracket 80 meter (D1) alongside the larger 80 meter coil of coil assembly 80/40 meter (C). Secure with a #10 flat washer, lock washer and hex nut.
 13. Attach the tab end of capacitor bracket 80 meter (D1) to tube (B) with capacitor bracket clamp and secure with # 8 x 1" screw, lock washer and a hex nut.
 14. Attach the tab end of capacitor bracket 40 meter (D2) to tube (B1) as above.
 15. Insert the un-slotted end of tube (E) into tube (B1) and secure with a # 8 x 1 1/2" screw, lock washer and hex nut.
 16. Locate coil support tube 30 meter (O) and measure to a point 9 7/8 in (25.1 cm) down from the plastic insulator. Mark this point with a pencil.
 17. Locate coil support tube 30 meter L bracket (O1) and place the tabbed end inside of the coil support tube 30 meter (O) securing it with a # 8 x 3/4" screw, lock washer and hex nut.
 18. Place a #10 washer, lock washer and wing nut on the lower single clamp of coil/capacitor assembly 30 meter (P).
 19. Place a #10 washer, lock washer and hex nut on both upper clamps of coil/capacitor assembly 30 meter (P).
 20. Pass the lower single clamp of coil/capacitor assembly 30 meter (P) over the insulator end of coil support tube 30 meter (O) and slide the coil downward along the tube until the upper edge of the upper clamp is flush with the end of the insulator. Align the upper clamp with the coil support tube 30 meter L bracket (O1) and tighten the hex nut.

ASSEMBLY

21. Stretch the coil until the bottom of the bottom clamp on the coil/capacitor assembly 30 meter (P) is even with the mark on coil support tube 30 meter (O) and tighten the wing nut.
22. Slide the remaining clamp from the above assembly over tube (E) and position it so the coil support tube L bracket (O1) is even with fourth turn, counting from the top of the 40 meter coil on the coil assembly 80/40 meter (C) and tighten the hex nut.
23. Hook the coil support tube 30 meter L bracket (O1) around the fourth turn of the 40 meter coil on coil assembly 80/40 meter (C). Secure with a # 8 x 3/4" screw, lock washer and hex nut.
24. Position wire clamp 0.875" 15 M w/insulator (K) around tube (F) and use a # 8 x 1" screw, lock washer and hex nut finger tight.
25. Insert the un-slotted end of tube (G) into the slotted end of tube (F) and secure with a # 8 x 1 1/4" screw, lock washer and hex nut.
26. Locate wire clamp 0.750" 15 M w/insulator (N) and position it around tube (G).
27. Insert the un-slotted end of tube (H) into the slotted end of tube (G) and secure with a # 8 x 1" screw, lock washer and hex nut.
28. Locate wire clamp 0.625" 15 M w/insulator (M) and position it around tube (H).
29. Insert the un-slotted end of tube (I) into the slotted end of tube (H) and secure with a # 8 x 1" screw, lock washer and hex nut.
30. Position wire clamp 0.500" 15 M w/wire around tube (I) so the top edge is 13.5 (34.3 cm) from the upper end of the tube.
31. Measure from the rivet of wire clamp 0.500" 15 M w/wire (L) to a point 11 ft 3 in (3.4 m) along the stranded wire and mark this point.
32. Pass the free end of the stranded wire from wire clamp 0.500" 15 M w/wire (L) through the small holes in wire clamp 0.625" 15 M w/insulator (M) and wire clamp 0.750" 15 M w/insulator (N) as shown.
33. Loop the end of the wire through the hole in wire clamp 0.875" 15 M w/insulator (K) sliding it on tube (F) until the mark on the wire appears. Wind the wire back on itself. Do not cut off the excess wire.
34. Line up wire clamp 0.875" 15 M w/insulator (K), wire clamp 0.750" 15 M w/insulator (N) and wire clamp 0.625" 15 M w/insulator (M) with wire clamp 0.500" 15 M w/wire (L) and tighten all clamps making sure the wire is moderately taut but not enough to cause the upper tubing section to bow.

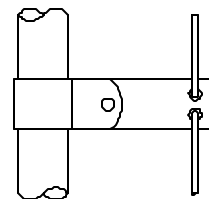

ASSEMBLY

35. Place the protective cap on one end of tube (J).
36. Slide the uncapped end of tube (J) into the slotted end of tube (I) until only 25 in (63.5 cm) extends and secure with compression clamp small adjustable.

NOTE: In the following steps the antenna will be assembled and raised to its full vertical height. If the antenna is to be installed in an elevated position where it is unsafe or inconvenient to make in-place adjustments, the antenna may have to be installed in one piece. It will probably be necessary to raise and lower it and its supporting structure a number of times to arrive at the *ideal* adjustment on all bands. If so, every precaution should be observed in order to avoid possible contact with power lines and to prevent structural failure that can cause injury to persons or property.

37. Place the lower end of tube (B) through tube (E) over the insulator on tube (A) w/insulator. Line up the holes and secure it with a # 8 x 2" screw, lock washer and hex nut.

WARNING: AVOID POWER LINES!

38. Raise the assemble of tube (F) through tube (J) and slide the lower end into tube (E) fastening it securely with a # 8 x 1 1/4" screw, lock washer and hex nut.
39. Install coax 75 ohm matching (R) as shown placing the lug from the center conductor over the screw on tube (B) and the braid over the screw on tube w/insulator (A).
40. Place # 8 washers over each screw and install coil (Q) base matching. Secure with washers, lock washers and hex nuts.

NOTE: Attach radials and ground to tube w/insulator (A) using the remaining # 8 hardware.

WARNING: MAKE SURE THAT THE STATION EQUIPMENT IS CONNECTED TO A GOOD EARTH GROUND! DO NOT HANDLE CABLE CONNECTED TO STATION EQUIPMENT WITHOUT FIRST DISCONNECTING THE EQUIPMENT FROM THE POWER MAINS. YOU COULD BE ELECTROCUTED!

41. Connect coax 75 ohm matching (R) to any length of 50-53 ohm coaxial cable. Connector PL258 (S) is provided. Seal the connection with the small roll of Konnector-Kote.

CHECKOUT AND ADJUSTMENT

The dimensions and coil settings given above should produce reasonably low VSWR readings over the entire 10, 15, 20 and 30 meter bands and over at least 250 kHz of the 40 Meter band. Bandwidth on 80/75 meters should be at least 30 kHz for VSWR of 2:1

CHECKOUT AND ADJUSTMENT

or less at the low end of the band and may be as much as 100 kHz at the high end of the band, depending on the efficiency of the ground system used, greater bandwidth being associated with lossy ground systems. It should be remembered that on those bands where the physical height of a vertical antenna is less than a quarter wavelength, the earth (or the resonant radial system in above-ground installations) will have a good deal to do with VSWR and antenna tuning, bandwidth and overall performance.

Low VSWR by itself does not mean that a vertical antenna is operating efficiently, and if low VSWR is obtained with no more than the usual *quick and dirty* ground connection, it most likely means the opposite. In general, poor operation or improper tuning of vertical antennas can usually be attributed to inadequate (or even reactive) ground systems or to other vertical conductors in the vicinity of the antenna. For these reasons it is suggested that the antenna be placed as much in the clear as possible and used with the best ground system that conditions permit. For a more complete discussion of the interrelationships between vertical antenna efficiency, bandwidth, VSWR, etc., a standard text such as the A.R.R.L. Antenna Book is recommended. See also the material included at the end of these instructions.

For adjustment purposes a simple VSWR indicator may be used. More accurate measurements may be made at the antenna (i.e., at the junction of the coax 75 ohm matching (R) and the main transmission line) than at the input end of the line, but the tuning conditions that exist at the transmitter will usually be of greater interest in that one's principal concern will be to couple power from the transmitter into the transmission line.

1. Determine the frequency at which VSWR is lowest on 80/75 meters. The coil setting given earlier should produce resonance and lowest VSWR at approximately 3700 kHz. To raise the frequency of resonance of the lowest VSWR, simply loosen the wing nut on the lower coil clamp of the coil assembly 80/40 meter (C) coil on tube (B) and stretch the coil a bit more. To lower the frequency, compress the coil. A 1 in (2.5 cm) change in the setting of this coil will produce a frequency shift of approximately 125 kHz.

NOTE: Remember that the antenna tunes very sharply in this range and that high values of VSWR may be encountered only a few kHz either side of the lowest VSWR readings, so it would be well to take VSWR readings every 25 kHz or so to avoid *running past* the frequency of resonance and lowest VSWR.

NOTE: To minimize interference to other stations and to avoid erroneous reading use only enough power to produce full-scale deflection of the meter in the *forward* or *r.f. out* position.

2. Once the proper coil setting has been found for the desired band segment, coil (Q) base matching at the base of the antenna may be adjusted for even lower VSWR. If earth losses are moderate to high a good match may be possible if coil (Q) base matching is left fully compressed; if earth losses are low (as with an extensive radial system) coil (Q) base matching may have to be stretched to twice its compressed length or more for a good match. In any case, a single setting for coil (Q) base

CHECKOUT AND ADJUSTMENT

matching should suffice for operation over most of 80/75 meters provided the 80 meter coil is readjusted for each different band segment.

3. Determine the frequency of minimum VSWR on 40 meters. The coil setting given earlier should produce resonance and lowest VSWR at approximately 7150 kHz. The 40 meter VSWR and resonance curve may be shifted in the same manner as on 80/75 meters by changing the setting of the upper coil clamp of coil assembly 80/40 meter. On this band the setting is much less critical, and a 1 in (2.5 cm) change in the clamp setting will shift the VSWR curve approximately 80 kHz. Be sure to loosen the clamp around tube (E) that supports the 30 meter assembly and to reposition it as needed to avoid distorting the 40 meter coil.
4. Check VSWR on 20 meters. Tuning is quite broad on this band because the antenna is physically much taller than a quarter wavelength. To raise the frequency of the lowest VSWR, reposition the 30 meter assembly so that the coil support tube 30 meter L bracket (O1) can be replaced on the next lower turn of the 40 meter coil. Alternatively, to lower the frequency of lowest SWR, reconnect the coil support tube 30 meter L bracket (O1) to the next higher turn of the 40 meter coil. In some cases moving the tap point a full turn up or down may cause more of a frequency shift than is desired, in which case the entire 30 meter assembly may be rotated around tube (E) to permit adjustments of less than one full turn.
5. Check VSWR on 15 meters. The VSWR curve may be shifted upward or downward by changing the length of the stranded wire between wire clamp 0.500" 15 M w/wire (L) and wire clamp 0.875" 15 M w/insulator (K). To raise the frequency, simply shorten the wire by wrapping a longer *tail* back on itself and sliding the lower clamp upward to maintain tension. To lower frequency, feed more of the *tail* back through the hole in the insulator to increase the length of the wire between wire clamp 0.500" 15 M w/wire (L) and wire clamp 0.875" 15 M w/insulator (K). A change of 2 in (5.1 cm.) will shift the VSWR curve approximately 300 kHz.
6. Check VSWR on 10 meters. To raise the resonant frequency loosen the small hose clamp over the slotted end of tube (I) and slide tube (J) farther into tube (I); to lower the frequency, slide tube (J) farther out of tube (I) and retighten the hose clamp. A length change of 3 in (7.6 cm) should move the VSWR curve approximately 200 kHz.
7. Check VSWR on 30 meters. To raise frequency, loosen the wing nut on the bottom coil clamp of coil/capacitor assembly 30 meter (P), stretch the coil and retighten the wing nut. To lower frequency, compress the coil. A change of only 1/4 in (6.4 mm) will shift the VSWR curve approximately 100 kHz. Large changes in the setting of coil/capacitor assembly 30 meter (P) may affect 20 and 40 meter tuning, in which case it may be necessary to repeat steps 3 and 4. In general, the point at which the 30 meter coil taps on to the 40 meter coil will be the major factor in 20 meter tuning.
8. Adjustments for 40, 30, 20, 15 and 10 meters should have little or no effect on the previous adjustments for 80/75 meters, but a final VSWR check for this band should be made as in step 1 above.

NOTE: In above-ground installations it will usually be found that

CHECKOUT AND ADJUSTMENT

resonance and lowest VSWR occur at slightly higher frequencies on all bands compared to ground-level installations. Therefore on 15 and 10 meters, where length adjustment is the means of getting antenna resonance, it is recommended that the length of the stranded-wire between wire clamp 0.500" 15 M w/wire (L) and wire clamp 0.875" 15 M w/insulator (K) be increased approximately 3 in (7.6 cm.) and that tube (J) be extended approximately 6 in (15.2 cm.) beyond the original dimensions given if any above-ground installation is contemplated. These are merely recommended preliminary settings, for it is impossible to indicate precise settings that will produce resonance or lowest VSWR at a given frequency in all installations.

In the preceding steps it has been assumed that the antenna has been installed in a more or less clear spot away from other vertical conductors such as TV antenna feedlines, towers and masts, and that a minimal ground system (or a system of resonant radials in the case of above-ground installations) has been installed.

If those fairly basic conditions have not been met it is likely that resonance and low VSWR will be impossible on some or even all bands. One should bear in mind that VSWR, even with a resonant antenna, will depend in large measure on local ground conductivity, height above ground in the case of an elevated antenna, the extent of the radial, counterpoise or other ground system used, and on other factors over which the operator may have little or no control. Fortunately, the evils of VSWR greater than unity have been grossly exaggerated in recent decades, and the only practical difference between a VSWR of unity and one of, say, 3:1 in the average case lies in the reluctance of modern equipment to deliver full power into lines operating at the higher VSWR without the help of a transmatch or other outboard matching device. Transmitters having so-called broadband solid-state output circuits (no tuning or loading controls) may be especially troublesome in this regard, whereas the older vacuum tube pi-network transmitters can usually be adjusted for maximum output over a tuning range where the VSWR does not exceed 2:1.

THEORY OF OPERATION

The first L/C circuit generates enough reactance to bring the whole HF6V to resonance on 80 meters allowing it to act as a $1/4 \lambda$ radiator. It also generates enough *capacitive* reactance to produce another discrete resonance at about 11 MHz. The second, 40 meter L/C circuit generates enough reactance to resonate the whole HF6V allowing it to act as a $1/4 \lambda$ radiator. In order to minimize conductor and I²R losses an 80 and 40 meters where the antenna is physically shorter than a $1/4 \lambda$ and thus operates with lower values of radiation resistance, large-diameter self-supporting inductors and low-loss ceramic capacitors are employed. Where the height of the HF6V is slightly greater than a $1/4 \lambda$ on 30 meters, an L/C series tuned circuit taps onto the 40 meter coil for the extra inductance to pull the earlier 11 MHz secondary resonance down to 10 MHz. At the same time, a portion of the 40 meter coil is shorted out which allows the circuit to resonate on 30 meters. The addition of this circuit also produces additional resonances at 14 MHz and 28 MHz. On 20 meters the entire radiator operates as a $3/8 \lambda$ vertical with much higher radiation resistance and VSWR bandwidth than conventional or *trapped* antennas having a physical height of $1/4 \lambda$ or less. Because the 20 meter radiation resistance will be several

THEORY OF OPERATION

times as greater as that of conventional vertical antennas, an electrical $1/4 \lambda$ section of 75-ohm coax is used as a *geometric mean* transformer to match the 100-ohm S of feedpoint impedance on that band to a 50 S main transmission line of any convenient length. The HF6V operates as a slightly extended $1/4 \lambda$ radiator on 15 meters, a $1/4 \lambda$ stub decoupler providing practically lossless isolation of the upper half of the antenna on that band. On 10 meters the HF6V becomes a $3/4 \lambda$ radiator with considerably greater radiation resistance and efficiency than $1/4 \lambda$ trapped types.

ELECTRICAL AND MECHANICAL SPECIFICATIONS

Height (adjustable): 26 ft (7.9 m)

Shipping Weight: 14 lbs (6.3 kg)

Feedpoint Impedance: Nominal 50 ohms through included matching line.

VSWR at resonance: 1.5:1 or less all bands

Power rating: 2 kW PEP 75/80, 40, 20, 15, 10 meters; 500 W PEP 30 meters

Wind loading area: 2 ft² (.19 m²)

Bandwidth for VSWR of 2:1 or less: entire band 10, 15, 20, 30 meters, 250-300 kHz
40 meters, 40-100 kHz 75/80 meters

GUYING

The HF6V is designed to survive winds of up to 80 mph (129 kph) without guying in the absence of ice loading or heavy precipitation, but over a period of time it is to be expected that frequent or even constant flexing or vibration will reduce the chances for survival in winds that would not damage a newly installed antenna. Therefore in areas of frequent or heavy winds a set of short non-conductive guys should be used to reduce the stresses that wind loading will impart to the lower sections of the antenna. In this connection, it should be noted that light nylon twine is totally unsuitable as guying material because it has too much stretch per unit length, although the heavier sizes of nylon rope (or even sash cord) may be suitable if used in short runs. Polyethylene rope may be used, but because some grades tend to deteriorate fairly rapidly, periodic inspection should be made. A single set of guys placed just above the 30 meter circuit will contribute greatly to the stability and the longevity of the antenna, provided that the guys retain a slight amount of slack and do not come off at too steep an angle. At Angles of less than 45° the guys begin to exert a downward compressive force on the structure that can be more of a threat to survival than lateral wind loading on an unguyed structure. Under no circumstances should guys be placed higher than one-third of the way up the antenna. The upper two-thirds of the HF6V has little more than its own weight to support, so these sections may be allowed to bend with the wind with no serious risk of damage. It is the lower third of the antenna that must support both the weight of the upper sections and the wind loading on them and are thus more likely to receive damage in severe winds.

PARTS LIST/PICTORIAL

NOTE: All dimensions are in inches(millimeters) unless otherwise noted

| Cod e | Part No | Description | Qty |
|-------|----------|---|-----|
| A | 00278SZV | TUBE A W/INSULATOR 1-1/8(29) X 24(606) | 1 |
| B | 00115BAV | TUBE 1-1/8(29) X 48(1216) | 1 |
| B1 | 00365SZV | TUBE B1 W/INSULATOR 1-1/8(29) x 12(302) | 1 |
| C | 00145SZV | COIL ASSEMBLY 80/40 METER | 1 |
| D | 290-07 | CAPACITOR ASSEMBLY 80/40 METER | 1 |
| D1 | 00150BAV | CAPACITOR BRACKET 80 METER | 1 |
| D2 | 00220BAV | CAPACITOR BRACKET 40 METER | 1 |
| E | 00123BAV | TUBE 1(25) X 48(1216) | 1 |
| F | 00124BAV | TUBE 7/8(22) X 48(1216) | 1 |
| G | 00125BAV | TUBE 3/4(19) X 48(1216) | 1 |
| H | 00126BAV | TUBE 5/8(16) X 48(1216) | 1 |
| I | 00127BAV | TUBE 1/2(13) X 48(1216) | 1 |
| J | 00175BAV | TUBE 3/8(10) X 36(911) | 1 |
| K | 00286RZV | WIRE CLAMP 7/8(22) 15M W/INSULATOR | 1 |
| L | 00280RZV | WIRE CLAMP 1/2(13) 15M W/WIRE | 1 |
| M | 00281RZV | WIRE CLAMP 5/8(16) 15M W/INSULATOR | 1 |
| N | 00282RZV | WIRE CLAMP 3/4(19) 15M W/INSULATOR | 1 |
| O | 00204SZV | COIL SUPPORT TUBE 30 METER 1-1/8(29) X 9(225) | 1 |
| O1 | 00176BAV | COIL SUPPORT TUBE 30 METER L BRACKET | 1 |
| P | 00249SZV | COIL/CAPACITOR ASSEMBLY 30 METER | 1 |
| Q | 00137SZV | COIL Q BASE MATCHING | 1 |
| R | 290-08 | COAX 75 OHM MATCHING | 1 |
| | 00077JZV | # 8-32 X 3/4(19) SCREW | 3 |
| | 00078JZV | # 8-32 X 1(25) SCREW | 5 |
| | 00079JZV | # 8-32 X 1-1/4(32) SCREW | 3 |
| | 00080JZV | # 8 LOCK WASHER | 18 |
| | 00081JZV | # 8-32 HEX NUT | 18 |
| | 00083JZV | # 8 FLAT WASHER | 7 |
| | 00109JZV | # 8-32 X 2(51) SCREW | 2 |
| | 00114JZV | # 8-32 X 1-1/2(38) SCREW | 3 |
| | 00131JZV | #10-24 X 1(25) SCREW | 2 |
| | 00132JZV | #10 FLAT WASHER | 8 |
| | 00133JZV | #10 LOCK WASHER | 8 |
| | 00134JZV | #10-24 HEX NUT | 4 |
| | 00135JZV | #10-24 WING NUT | 5 |
| | 00050DZV | KONNEKTOR-KOTE 1(25) X 8(203) | .05 |
| | 00089FZV | PROTECTIVE CAP 0.375 | 1 |
| | 00143BAV | CAPACITOR BRACKET CLAMP | 2 |
| | 00144JZV | COMPRESSION CLAMP SMALL ADJUSTABLE | 1 |
| | 00061SZV | BUTTER-IT'S-NOT | 1 |
| | 00366IZV | INSTRUCTIONS HF6V | 1 |

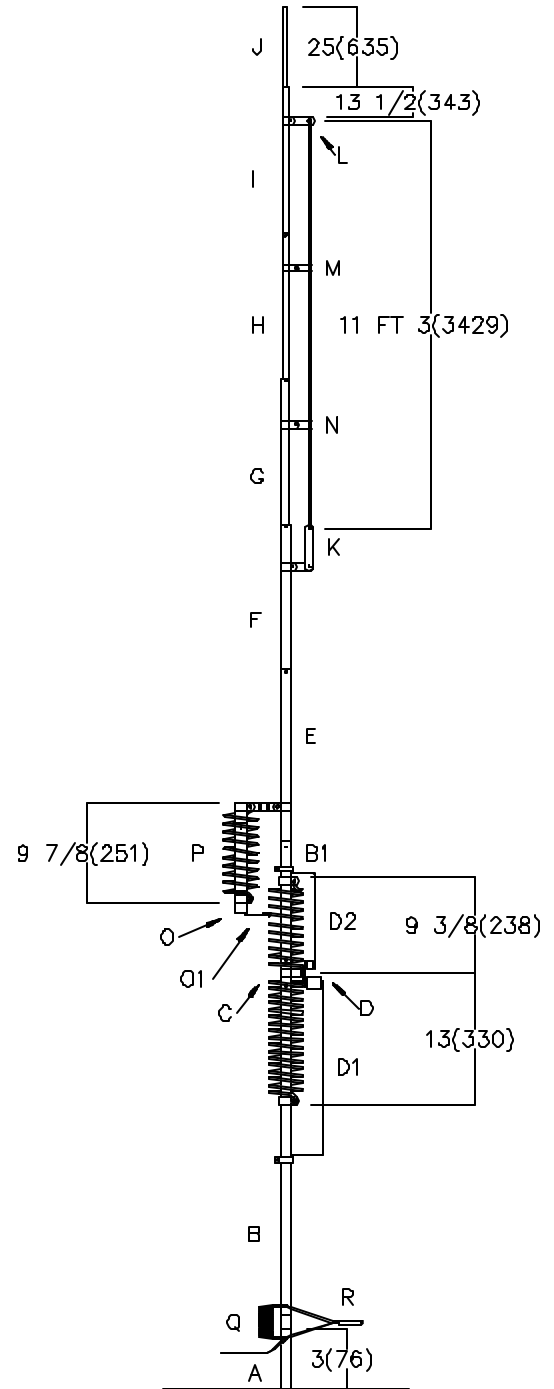

TECH NOTES—GROUND RADIAL SYSTEMS

MOUNTING TUBE INSTALLATION

When tube w/insulator (A) is ground mounted, it should be protected against corrosion if placed in concrete, damp acidic or alkaline soil. Asphalt roofing compound, polyurethane varnish or other sealant that protects against moisture may be used.

Concrete may be used in areas of high winds for greater strength, in which case the post may be twisted slightly during setting for easy removal later.

Tube w/insulator (A) must be installed in a hole approximately 21 in (53.3 cm) deep so that the upper end of the fiberglass insulator is approximately 7 in (17.8 cm) above ground level. Pack earth tightly around tube w/insulator (A) so that it remains vertical.

NOTE: HAMMERING TUBE W/INSULATOR (A) INTO THE EARTH MAY CAUSE THE INSULATOR TO SPLINTER. If the post must be hammered into the earth, protect the end of the insulator with a block of wood

NOTE: DO NOT USE U-BOLTS TO ATTACH TUBE W/INSULATOR (A) TO A MAST, TOWER ETC. U-BOLTS WILL EVENTUALLY CUT INTO THE TUBING AND WEAKEN THE INSTALLATION. If U-bolts must be used, place a larger diameter metal, such as the MPS Mounting Post Sleeve over tube w/insulator (A). Similar precautions should be observed when using TV style towers with locking bolts.

The RMK-II Roof Mounting Kit includes the MPS as well as the STR-II Stub Tuned Radial Kit.

GROUND MOUNTING

A vertical antenna in its simplest form, is electrically equivalent to one-half of a dipole antenna stood on end. When the antenna is mounted close to the ground, the earth below takes the place of the "missing" half of the dipole. If ground conductivity is fair to good, a short metal stake or rod may provide a sufficiently good ground connection for resonant and low SWR operation on the bands for which the antenna is designed. This basic arrangement is shown in figure 1.

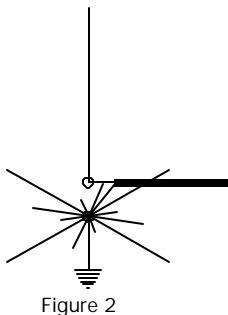
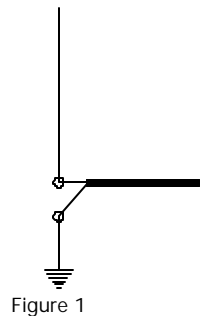

The way it works is that the capacitance between the vertical radiator and the ground causes *return* currents to flow along the earth's surface back to the transmitter. If they have to come back along untreated lossy earth they get back to the source greatly attenuated. This *return* loss is like a resistor in series with the antenna radiation resistance and will therefore affect the feed point impedance. In almost every case the efficiency of a vertical antenna will be greater if radial wires are used to improve ground conductivity as in figure 2. It's important to note that there's no point in cutting radials to any particular length when ground mounting because the earth will detune them anyway.

All you want to do is make the surface of the earth around the antenna more conductive than it is ordinarily.

TECH NOTES—GROUND RADIAL SYSTEMS

If you can't copper-plate the backyard, the best approach is to run out as many radials as possible, each as long as possible around the antenna in all directions. Radials may be left on top of the ground however they should be buried for the sake of pedestrians and lawnmowers.

How long should radials be? A good rule is no shorter than the antenna is tall because 50% of your losses will occur in the first 1/4 λ out from the antenna. If you have more than a dozen radials, they must be longer to get the most out of them which is why the FCC specifies 113 wires each .4 λ for AM broadcast stations—the equivalent of a zero-loss ground plane. Obviously, for most ham work this would be overkill.

In some cases wire mesh (i.e. chicken wire) may be used as a substitute for radial wires and/or a ground connection, the mesh or screen acting as one plate of a capacitor to provide coupling to the earth beneath the antenna.

It should be noted that a ground rod is useful only as a d.c. ground or as a tie point for radials. It does little or nothing to reduce ground losses at r.f. regardless of how far it goes into the ground.

Bare wire, insulated, any gauge, it doesn't matter. The current coming back along any one wire won't amount to that much.

EFFICIENCY

The importance of reducing losses in the ground system can be seen from an examination of a vertical antenna's feedpoint impedance which at resonance consists of three components: antenna radiation resistance; conductor loss resistance; and earth loss resistance. An unloaded quarter-wave vertical antenna has a radiation resistance of about 35 ohms with negligible ohmic or conductor loss, but ground loss resistance may be very great if no measures are taken to reduce it, and in some cases ground loss R may even exceed the antenna radiation resistance. These three components may be added together to arrive at the feedpoint **impedance** of a **resonant** (no reactance) antenna. For the sake of illustration, assume that the ground loss beneath a quarter wavelength vertical antenna is 15 ohms, that conductor loss resistance is zero, and that the radiation resistance is the textbook figure of 35 ohms. The feedpoint impedance would then be $15 + 0 + 35 = 50$ ohms, and the antenna would be perfectly matched to a 50 ohm coaxial line. Since the radiation resistance is an index of the amount of applied power that is consumed as useful radiation rather than simply lost as heat in the earth or in the conductor, the radiation resistance must be kept as high as possible in relation to the total feedpoint impedance for maximum efficiency. Efficiency, expressed as a percentage, may be found by dividing the radiation resistance by the total feedpoint impedance of a resonant antenna, so under the conditions assumed above our vertical antenna would show an efficiency of $35/50 = 70\%$. As a vertical antenna is made progressively shorter than one-quarter wavelength the radiation resistance drops rapidly and conductor losses from the required loading inductors increase. A one-eighth wave inductively loaded vertical would have a radiation resistance of something like 15 ohms and coil losses (or trap losses for multiband antennas) would be in the range of 5 ohms. Assuming the same value of ground loss resistance (15 ohms), the feedpoint impedance would become $15 + 5 + 15 = 35$ ohms and

TECH NOTES—GROUND RADIAL SYSTEMS

the efficiency would be $15/35 = 43\%$. From the above calculations it is clear that the shorter a vertical antenna must be the less efficient it also must be for a given ground loss resistance. Or to state the matter another way, more elaborate ground or radial systems must be used with shorter verticals for reasonable efficiency. If the ground loss of resistance of 15 ohms from the preceding example could be reduced to zero ohms, it is easy to show that the efficiency of our one-eighth wavelength loaded vertical would increase to 75%. Unfortunately, more than 100 radials each one-half wavelength long would be required for zero ground loss, so lower efficiencies with shorter radials must usually be accepted for the sake of convenience. In spite of their limitations, short vertical antennas over less than ideal ground systems are often more effective DX performers than horizontal dipoles which must be placed well above the earth (especially on the lower bands) to produce any significant radiation at the lower elevation angles. Verticals, on the other hand, are primarily low-angle radiators on all bands.

ABOVE GROUND (ELEVATED) INSTALLATIONS (rooftop, tower, mast. etc.)

The problem of ground loss resistance may be avoided to some extent by mounting a vertical antenna some distance above the earth over an artificial ground plane consisting of resonant (usually $1/4 \lambda$) radial wires. Four resonant radials are considered to provide a very low-loss ground plane system for vertical antennas at base heights of $1/2 \lambda$ or more. This arrangement contrasts favorably with the more than 100 radials for zero ohms loss resistance at ground level, and since $1/2 \lambda$ is only about thirty-five feet at 20 meters, very worthwhile improvement in vertical antenna performance can be realized, at least on the higher bands, with moderate pole or tower heights. At base heights below $1/2 \lambda$ more than four radials will be required to provide a ground plane of significantly greater conductivity than the lossy earth immediately below the antenna: even so, a slightly elevated vertical with relatively few radials may be more effective than a ground-level vertical operating over a larger number of radials if only because the former is apt to be more in the clear. Resonant radial lengths for any band may be calculated from the formula:

$$\text{Length (ft)} = \frac{240}{\text{Frequency (MHz)}}$$

Figure 3 shows the basic ground plane system for elevated verticals.

Radials may slope downward as much as 45 degrees without any significant effect on operation or performance. Radials for different bands should be separated as much as possible and the far end of each radial insulated from supporting wires. Figure 4 shows a ground plane system that uses four resonant radials for 40 meters, another set of four for 20 meters, and a third set for 10 meters. A separate set for 15 meters is not ordinarily required because the 40 meter radials operate as resonant $3/4 \lambda$ radials on that band. At the lower heights the separate wires of this system may provide enough capacitance to ground to permit low SWR operation on 80/75 meters as well, but it is probable that at least one resonant radial will be required for low SWR on that band. It's important to note that cutting each conductor of rotator cable to a specific frequency will not work unless you separate it, angling each conductor away for most of its length because the longer ones will detune the shorter ones.

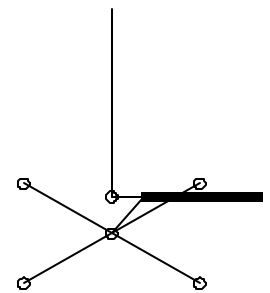
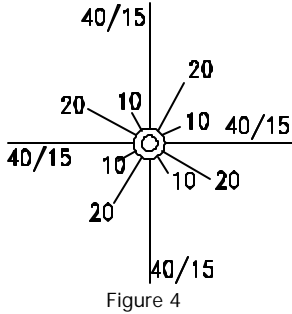

Figure 3

TECH NOTES—GROUND RADIAL SYSTEMS



The 12-radial system of Figure 4 is a very good one, but it requires at least 12 tie-off points. Butternut has developed a multiband radial made of 300-ohm ribbon that resonates simultaneously on 40, 20, 15 and 10 meters. Four such radials offer essentially the same ground plane performance as the system of Figure 4 but require only 4 supports. These multiband radials plus additional wire for an 80 meter radial are available separately (our STR-II kit) or as part of the Butternut roof mounting kit (RMK-II).

There are times when physical restrictions will dictate the use of fewer than four radials, and at least one manufacturer recommends 2 radials per band, the radials for each band running 180 degrees away from each other. A simpler (and no doubt less effective) system is shown in Figure 5. Since only one resonant radial is used per band the antenna will radiate both vertically and horizontally polarized energy, and the pattern will not be completely omnidirectional. For true ground plane action and predominantly vertical polarization no fewer than three equally-spaced radials should be used.

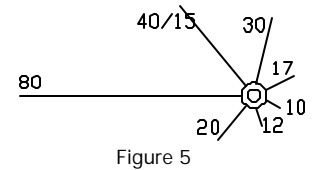
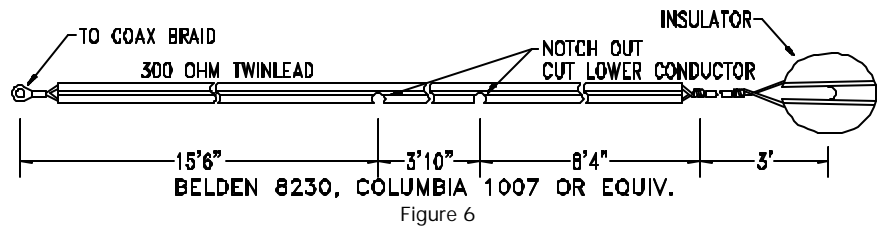

Figure 6 illustrates the construction of a multi-band radial which is resonant on 40, 20, 15 and 10 meters. Good quality 300 ohm TV ribbon lead should be used (velocity factor is critical), and the conductors should employ at least one strand of



steel wire to support the weight of the radial. Four such radials will be the practical equivalent of the system shown in figure four for operation on 40 through 10 meters.

Regardless of the number of radials used in either elevated or ground level systems, all radials should be attached to the ground connection at the antenna feedpoint by the shortest possible leads. An elaborate radial system at ground level, for example, cannot be used with a vertical antenna on a rooftop or on a tall tower, for the length of the ground lead would effectively become part of the antenna, thus detuning the system on most or all bands.

METAL TOWERS AND MASTS

If a metal mast or tower is used to support a vertical antenna all radials should be connected to the mast or tower at the ground connection of the antenna feedline. This is because one of the functions of a resonant radial is to detune a supporting metal structure for antenna currents that might otherwise flow on the structure and thus turn the vertical antenna system into a vertical long wire with unwanted high-angle radiation.

OTHER MOUNTING SCHEMES

In cases where a resonant vertical antenna may neither be ground mounted nor used with an elevated ground plane, operation may still be possible if connection can be made to a large mass of metal that is directly connected or capacitively coupled to the ground, e.g., central air

TECH NOTES—GROUND RADIAL SYSTEMS

conditioning systems or structural steel frames of apartment buildings. Some amateurs have reported good results with vertical antennas extended horizontally or semi-vertically from metal terraces which serve as the ground connection. Alternatively, a quarterwave vertical may be window mounted if a short ground lead to a cold water pipe or radiator can be used. If a long lead must be used, tuned radials may be required for resonance on one or more bands. Great care should be exercised in such installations to avoid power lines and to keep the antenna from falling onto persons or property.

MOBILE HOME AND RV INSTALLATION

The principles of vertical antenna installations for use on mobile homes or RV's are the same as for other installations, and they all boil down to two main considerations. The first is that of erecting the vertical in the clearest possible spot, away from obstacles (including the MH or RV) that can interfere with radiation from the antenna. The second is that of installing the best possible ground system beneath the antenna in order to minimize losses from r.f. currents flowing in the earth below the antenna. Fortunately, the metal bodies of both MHs and RVs can be used as highly conducting ground planes for vertical antennas in exactly the same way that automobile bodies, etc., provide the ground system for shorter vertical antennas for mobile operation. The metal body of an automobile, MH or RV may be viewed as one plate of a capacitor. Since the surface area of even a small automobile is quite large and in close proximity to the earth, its body is tightly coupled to the earth below and may be considered simply as an extension of the earth itself—a kind of hill as far as radio frequencies are concerned, but one having higher conductivity than the earth itself. RVs and especially MHs having much greater surface area, will therefore provide a more extensive and effective ground system than a large number of radial wires occupying the same space as the MH or RV.

As in mobile installations, a vertical antenna may be mounted almost anywhere on the body of the vehicle or MH and made to operate with reasonably low VSWR, but it is generally considered that the best possible location for a mobile antenna is in the middle of the roof of the vehicle, i.e., at the center of the vehicle's ground plane and at a point where the antenna will not be in the "shadow" of any part of the vehicle. It is not usually convenient, or even practical to install a relatively tall vertical on the roof of an RV or MH for any number of reasons, so the next best procedure would be to install a vertical antenna with its base at the same level as the roof, preferably near the middle of one of the longer sides. The exact way in which this may be done is a matter of convenience, but a short mast extending from ground level to the roof of the MH and RV and placed alongside the building or RV would provide a stable and sturdy support with a minimum of mounting brackets and other modifications to the RV or MH. For portable operation such a mast could simply be lashed alongside the RV with the base in a shallow hole in the ground for additional support, and there would be no harm in extending the mast a few inches above the roof level to permit attachment of ropes which could be used to hold the mast firmly against the side of the vehicle and to prevent side sway.

This system has been used successfully with various types of RVs, travel trailers and even passenger automobiles during portable operation. For "L" shaped mobile homes a vertical antenna should be placed in the corner of the "L" so that the metal roof will provide groundplane coverage over 270 degrees.

TECH NOTES—GROUND RADIAL SYSTEMS

In all cases the base of the vertical antenna should not be more than a few inches away from the MH or RV so that the shortest possible lead may be run from the ground connection of the antenna to the metal body, as the length of this ground lead will effectively lengthen the antenna itself on all bands, and detuning can occur in some cases. A good electrical connection between the body of the RV or MH and the antenna is important, and in the case of mobile homes it would be a good idea to make sure that good electrical contact exists between the different parts of the metal body. Discontinuities can often lead to the production of harmonic radiation and TVI. The essential circuit connections are shown in the diagram above.

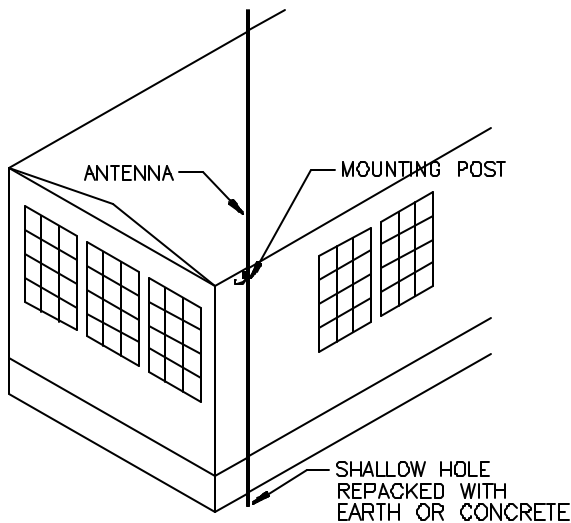
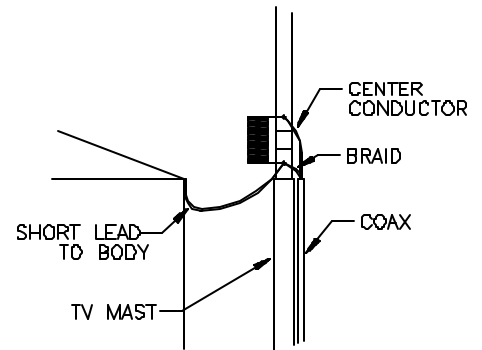

For permanent installations the bottom of the mast may be set deeper in the ground, and concrete may be used for greater strength and stability. The upper portion of the mast should be securely attached to the side of the building. Steel TV mast sections are readily available in lengths of ten feet and the mounting posts of Butternut HF verticals will slide into those which have an outside diameter of 1 1/4 inches and a wall thickness of .058 inches. Other vertical antennas may use different mounting techniques and requirements, so be sure to select a mast that will be suited to the particular situation. The main point to keep in mind is that the mast should not extend more than a few inches above the level of the roof so that the ground lead may be kept short.

LIGHTNING PROTECTION

Modern solid state amateur equipment is particularly vulnerable to damage from lightning or static induced transients that may appear on transmission lines, and conventional air-gap lightning protectors may provide no real protection at all for solid state gear. A line of very effective lightning and static protectors has been developed by ALPHA DELTA COMMUNICATIONS, P.O. Box 571, Centerville, Ohio 45459, for use with solid state equipment, and since these devices feature much faster transient discharge times than earlier designs, they should be investigated for possible use with all vertical and other antenna systems.

TROUBLESHOOTING

Check out your installation again, looking for loose connections and checking all dimensions. Then refer to the list of possible symptoms below:

Symptom: Few or no signals heard: bands seem *dead*, SWR is very high.

Look for: Open or shorted feedline, open or shorted matching line, broken connection at base of antenna (feedpoint).

Symptom: High SWR on 20 meter; other bands OK.

Look for: Missing matching line. Antenna not properly tuned. 20 meter radials not present or wrong length. Consult instructions for tuning and radial information; install matching line *RG-11 75 ohm coax, 11 ft 4 in (345.4 cm) if solid dielectric, 13 ft 6 in (411.5 cm) if foam type*.

Symptom: High SWR on some bands, but signals heard on all bands (conditions permitting).

Look for: Missing or defective radial system. Install as per instructions and check connections to radials and ground system. Keep this connection 6 in or less.

Symptom: High SWR on one band when antenna is roof-mounted. Radials are in place, but antenna will just not tune.

Look for: Radials of wrong length or running close to metal rain gutters or roof flashing. Tune radials and/or reroute them away from metal.

Symptom: Tuning is *sharp* with narrow bandwidth on 80 meter (and 160 meter if TBR-160-S is in place).

Look for: Normal condition. The total length of the antenna represents such a small percent of a wavelength on these bands that sharp tuning is a normal condition.

Symptom: Antenna was installed on the ground and tuned OK, but tuning changed over a period of weeks or months.

Look for: Antenna installed over poor ground system. Ground conditions have changed, causing shift in resonance. Install radial system as per instructions. Check connection to radial system. When you see this problem, you may assume that a ground rod without a radial system is not enough.

Symptom: Resonant point changes during wet weather.

Look for: Normal condition.

Symptom: Insulation arcs over between 80 meter and 40 meter coils damaging fiberglass.

TROUBLESHOOTING

Look for: Operation at high power levels in areas where salt or pollution deposits have built up on the insulators. The cure is to keep insulators clean through routine maintenance.

Symptom: Intermittent operation. SWR jumps up and down suddenly, and reception is also intermittent.

Look for: Loose connections in the feedline or matching line (if used). Bad relay in rig. Bad antenna switch or connecting cable. Broken or corroded connections at the feedpoint. Bad radial/ground connection. Radial or antenna contacting metal when wind blows. Loose hardware on the antenna. Check and secure all connections.

Symptom: Antenna displays generally degraded performance after long period of time.

Look for: Lack of routine maintenance. Coax may be waterlogged or damaged. Build up of salt or pollution deposits on insulators and capacitors. Radial system corroded or rotted away. Owner must do routine maintenance at intervals, according to local conditions.

Symptom: SWR is OK on 75 meter, but goes up gradually when high power is applied. This is accompanied by heating of 200pF capacitor.

Look for: Bad ceramic capacitor. Replace.

Symptom: Antenna doesn't tune 80 meter or 160 meter, even though radials are in place and of proper length.

Look for: Antenna far out of tune; operator has not followed systematic tuning procedure. Start with suggested settings in instructions. Make an SWR chart to determine point of resonance. Adjust coils *carefully!* Remember, tuning, is *sharp* on these bands, so it is easy to pass the resonant point, then assume erroneously that the antenna isn't tuning.

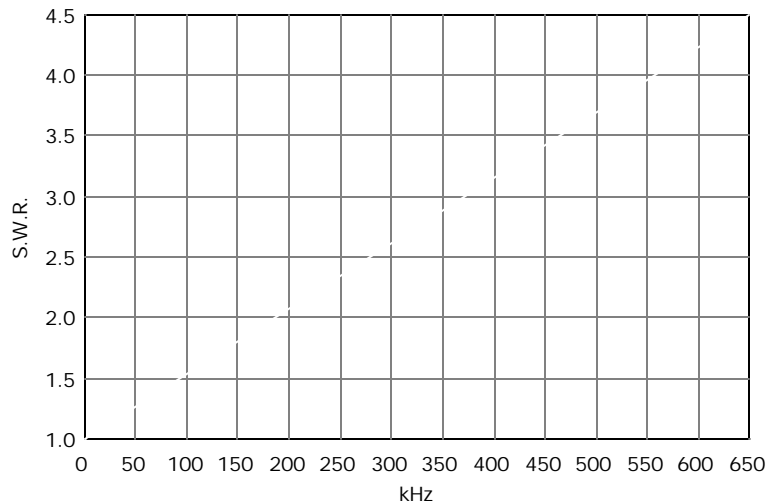

BEFORE you call the manufacturer for help, please double check your installation, including all connections and dimensions. Tune carefully and systematically. Have SWR curves available. Be prepared to describe your installation in detail.

LIMITED WARRANTY

Butternut Manufacturing Co. warrants on the terms hereof, to a Customer who has purchased a Product from a Seller, for a period of one year from the date of the purchase, that the Product was not Defective, but this warranty is void if the Product has been subjected to improper or abnormal installation or usage, or a serial number on the Product has been defaced or removed.

If a Customer believes that a Product is Defective, the customer may, within such one-year period, return the entire product to Butternut at Butternut's factory, all shipping charges pre-paid by the Customer. If the Product was Defective, Butternut will at its option and expense repair or replace the Product and will at its expense return the repaired or replaced Product to the customer, in a manner selected by Butternut, at the address from which the Customer sent the Product to Butternut.

THE ABOVE WARRANTY AND REMEDY ARE EXCLUSIVE AND ARE IN LIEU OF ALL OTHER WARRANTIES, EXPRESS OR IMPLIED, INCLUDING BUT NOT LIMITED TO IMPLIED WARRANTIES OF MERCHANTABILITY AND FITNESS FOR A PARTICULAR PURPOSE.

NO SELLER WILL BE LIABLE FOR ANY LOSS, INCONVENIENCE OR DAMAGE, INCLUDING DIRECT, SPECIAL, INCIDENTAL OR CONSEQUENTIAL DAMAGES RESULTING FROM THE USE OF OR INABILITY TO USE A PRODUCT, WHETHER THE LIABILITY WOULD RESULT FROM BREACH OF WARRANTY OR UNDER ANY OTHER LEGAL THEORY.

For instance, this warranty does not cover damage to or caused by an antenna (a) by reason of the antenna acting as a lightning rod, (b) by reason of corrosion or strain from exposure of an antenna to wind or weather, (c) from improper assembly, installation or use of an antenna, or (d) from failure periodically to inspect and maintain an antenna and its installation. The Customer is responsible to insure that installation and use of an antenna complies with applicable laws (such as zoning laws) and regulations (such as condominium regulations).

SOME LAWS DO NOT ALLOW THE EXCLUSION OF IMPLIED WARRANTIES, AND IF THESE LAWS APPLY, THEN ALL EXPRESS AND IMPLIED WARRANTIES ARE LIMITED IN DURATION TO SUCH ONE-YEAR PERIOD. NO WARRANTIES OF ANY KIND APPLY AFTER THAT PERIOD.

Such repair or replacement is the Customer's sole and exclusive remedy for a Defective Product. Specifically, Butternut is not liable (to the Customer or otherwise) for (a) any loss or damage arising in any way from a Product or from actual or anticipated sale, lease, license or use of a Product, or involving any matter such as interruption of service, loss of business or anticipated profits, or delay in receiving, repairing, replacing or returning a Product, or (b) any incidental, indirect, special or consequential damages.

No other person (such as an employee, agent or dealer) is authorized to change this warranty in any way, or to give any other warranties of any kind on behalf of Butternut. This warranty gives a Customer specific legal rights, and a Customer may also have other rights, which vary from state to state.

As used herein the *Customer* is the initial end-use purchaser of a Product from a Seller, a *Product* is an antenna or accessory therefor manufactured by Butternut, a Product is *Defective* if and only if the Product was not free of defects of material and workmanship when manufactured, and a *Seller* is Butternut and any authorized Butternut dealer.

Radiation&fields

[[Home](#)]

page moved to [Radiation and Fields](#)

Radiation Resistance

[[Home](#)] [[Up](#)]

Related pages on [Antennas](#) , [radiation and fields](#) , [mobile and short verticals](#)

My 2004 Dayton Hamvention Power Point presentation on Small Verticals can be downloaded here... [DAYTON 2004](#).

The main points when dealing with small antennas are:

There is no magic bullet or magic cure to make a small antenna act like a large one. It all comes down to current distribution over linear distance.

Small antennas require extraordinary care to obtain high efficiency.

How do we make a small antenna as efficient as possible?

- First, we make current as uniform as possible over the length of the antenna.
- Second, we use low loss loading such as optimum form (size, length, and diameter) [loading coils](#).
- Third, we make the antenna as large and straight as possible in a line. We don't fold, bend, zigzag, or curve the antenna especially in the high current areas.
- We keep the high voltage points (the open ends) away from other things (like lossy earth), and the high current areas away from other large lossy conductors.
- Most important, we keep current as high as possible throughout the length of the antenna by using as much capacitance as possible at the antenna ends.

What this does is maximize radiation resistance (while at the same time minimizing loss). The text below explains how radiation resistance and loss interact.

Radiation Resistance

Radiation resistance is probably the most abused and misused term in antennas. The reason it is so often misused is the lack of clear definition. When a term has several nebulous meanings and uses, it is only natural that misuses will appear. The lack of a firm well-accepted definition allows meanings to slip from one application into another, where a totally erroneous conclusion can be drawn from what otherwise would be a good formula!

Common Uses

There are two commonly used "correct" meanings of radiation resistance and one totally incorrect use. The "correct" uses are:

- The resistive part of an antenna's feedpoint impedance that is caused by radiation from the antenna
- The total EM power radiated in all directions divided by the square of net current causing the radiation

Neither of the above definitions include loss resistances of any type! The moment loss resistance is included, we have the third commonly used (but totally useless) definition. This definition, which includes losses, must be considered incorrect because it is comprised of resistances that have nothing to do with radiation. The misused definition is:

- The real (or resistive) part of an antenna's feedpoint impedance including loss related resistances.

The correct name for the third "radiation resistance is actually the antenna *feedpoint resistance*, not radiation resistance!

Of the above *good* definitions, the first definition is the most commonly abused through mistake. The second definition is an IRE definition (albeit a good one that never caught on). In every case I've seen, it is the second good definition that always provides the most direct and useful answer.

Examples of Misuse

Folded Monopoles

Folded monopoles probably provide the best examples of misuse of the term radiation resistance. Quite often, in discussions of folded monopoles, claims are made that multiple drops increase the radiation resistance and lower losses. The justification for this incorrect claim is the folding raises

radiation resistance, and $\% \text{ eff} = 100 * R_{\text{rad}} / (R_{\text{rad}} + R_{\text{loss}})$.

What folded monopole fanatics forget is that all losses must be normalized to the point where radiation resistance is taken, otherwise the efficiency formula won't mean a thing!

Let's look at what actually happens in a folded element, and use it to understand how the poor definition of radiation resistance causes the misunderstanding.

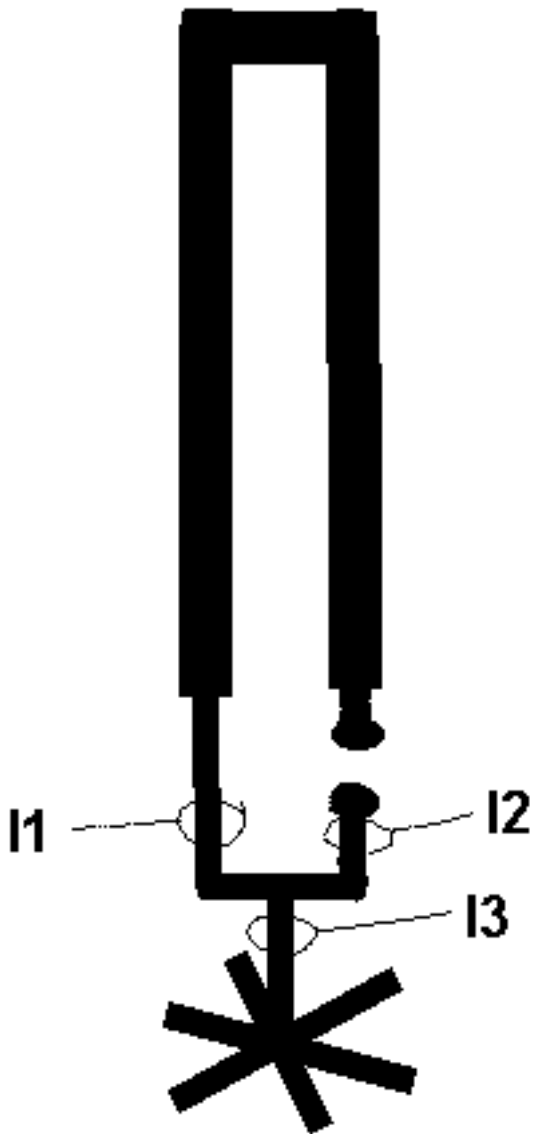

Consider the unipole above. Lets assume we short the open terminals, and feed it as a normal Marconi vertical with a feedpoint at the point where we measure I3. I3 is ALWAYS the vector sum or in-phase combination of currents I1 and I2. With continuity through each leg, I1 and I2 share all of the ground current. This happens regardless of where the feedpoint is located in the lower portions of the antenna.

With 1/4wl height and a reasonable element diameter, the radiation resistance (fed as a traditional monopole) would be about 36-ohms.

Assume ground loss, normalized to the point where we measure I3, could be represented by 14 ohms. Applying 500 watts would make current I3 equal 3.16 amperes. **Power loss in ground resistance would be I^2R , or 3.16^2 times 14, about 140 watts.** Feedpoint resistance would be 50 ohms. Feedpoint power, as a check, would be 3.16^2 times 50 ohms or 500 watts. With equal diameter legs, that current would divide and 1.58 amperes would flow in each upper leg.

Let's use the formula $\% \text{eff} = 100 * R_{\text{rad}} / (R_{\text{rad}} + R_{\text{loss}})$. We have $36 / (36 + 14) = .72$ so the result is 72% efficiency, 28% loss. **28% loss times 500 watts is 140 watts in ground losses.** This matches the other method just above.

Opening the terminals and feeding as a folded unipole, half of the radiator current is in I1 while the other half is in I2. Current is halved to 1.58 amperes at the feedpoint and power remains the same. The feedpoint resistance now becomes 200 ohms. We can confirm this with I^2R , or $1.58^2 * 200 = 500$ watts. It all works out great so far!

Now let's MIS-use the same efficiency formula, like Orr does in his Handbook and others do in various places. We would have $200 / (200 + 14) = .9346$ or 93.46 % efficiency.

We know we still have 3.16 amperes flowing as I3, and we know ground resistance is still 14 ohms (normalized to the point where I3 is measured). I^2R losses are $3.16^2 * 14 = 140$ watts! We have exactly the same power loss.

Let's transform the ground loss value that was normalized at 14-ohms where I3 is measured to the feedpoint by the same impedance multiplication as the feed resistance, or 1:4. We'd now think ground resistance would be $4 * 14 = 56$ ohms. 56 ohms of the feedpoint resistance is loss. Trying that same efficiency formula, we get:

$144 / (144 + 56) = .72$, or 72% efficiency!!! Now everything checks out fine.

The Common Mistake

Orr and others have used the first definition of radiation resistance, the portion of the terminal

resistance of the feedpoint responsible for radiation. Unfortunately *they failed to normalize ground losses to the same point where the radiation resistance was taken!*

We can not use a formula that is based on everything being normalized to one point, unless we actually do that for every term in the formula!

There is no change in efficiency when the NET radiator current remains the same, and when ground current remains the same. It is pathological engineering to think otherwise.

Using The Second Definition

If we use the second IRE definition of radiation resistance, where the effective current causing radiation is compared to power radiated, we find nothing changes. A folded dipole or monopole has the same radiation resistance as a regular dipole or monopole the same size, and a small loop has the same radiation resistance regardless of turns.

The magic vanishes along with the incorrect definitions and perceptions.

You can read about this in textbooks. The "Antenna Engineering Handbook" by Jasik in 3-13, 19-3, and in other sections uses correct definitions and descriptions.

Quad's and other Loops

We find the same efficiency misconceptions in articles about small loops and large quads. Authors sometimes assume, incorrectly, radiation resistance changes in a favorable proportion to loss resistance as we make the feed impedance increase. What we really are doing is placing the feedpoint in series with a smaller portion of NET current causing radiation.

With a large full-size quad element the pattern under some conditions will slightly change, but efficiency remains basically the same. With a small loop antenna, losses can actually increase with more turns!

Terminated Folded Elements

Another abuse of radiation resistance is found in terminated antennas. Some manufacturers and authors claim a resistance can be inserted in series with one leg of a folded monopole or folded dipole, and the other leg fed. The usual arm-waving claim is the antenna isn't really resistor loaded, and that efficiency is very good because radiation resistance is high.

That claim is absolute nonsense!

A large terminated Rhombic is well-known to have poor efficiency. Rhombic gain is actually low compared to other antennas having the same $\sin/\sin x$ antenna pattern, because Rhombic efficiency is generally less than 50%. At least half of the power is consumed in termination and ground losses below the antenna. The actual gain may be reasonably high compared to a dipole, but not to other efficient antennas with the same half-power beam width.

The typical manufacturing buzz-word is that terminated monopole and dipole antennas are "traveling wave antennas" and by some magic (that even large terminated Rhombic antennas can't achieve) have broad bandwidth and high efficiency.

A Rhombic focuses energy (that is not transformed into heat) into a narrow beam that has considerable gain, but if it sprayed the radiation around in a non-focused pattern, a regular dipole would win hands down. Throw a resistor on that dipole to smooth SWR variations, or on a vertical, and efficiency suffers.

I listened to a station on 75 meters 600 miles away testing a Sommer T-25 vertical. He was 30 over nine using a dipole, and dropped to S6 with the vertical. The European he was working reported a similar change. By removing the termination resistor and base-loading the same vertical, a local Ham gained almost 25dB on 80 meters!

When we abuse or misuse radiation resistance, we can invent all kinds of magical antennas. We can have CFA's, E-H antennas, terminated dipoles, small magnetic loops, and verticals with all sorts of magical claims. Few, if any, of the claims are ever correct. Any time we see a claim that efficiency changes a *large amount* because of feed method change, it should be a red flag.

Increasing Radiation Resistance

Radiation resistance, at least under the useful IRE definition, can be defined by the following formula:

$$R_{\text{rad}} := 160 \cdot \pi^2 \cdot \left(\frac{He}{\lambda} \right)^2$$

which would translate to:

$$R_{\text{rad}} := 1580 \cdot \left(\frac{He}{\lambda} \right)^2$$

Where He is the effective height center of accelerating charges that cause radiation. In other words,

H_e is the effective height, expressed in fractions of a wavelength, of the distributed common-mode current in the structure.

(Common-mode current is the vector sum of all currents, or the effective in-phase current at any point, or the current we would measure if we placed a giant clamp-on current probe around ALL of the conductors at that any given height.)

H_e and λ must both be in the same units, either given as degrees or decimal fractions of a wavelength.

As an example, a uniform current single conductor antenna has an actual physical height of 15.19 feet on 1.8 MHz, where one wavelength is 546.67 feet, the effective height is:

$$15.19/546.67 = 0.0278 \text{ wl}$$

Since charges are distributed evenly throughout the structure the full height is used. The effective height is .027 wl, the same as the physical height. The height in electrical degrees is $.0278 * 360 = 10$ degrees

We have a radiation resistance of:

$$H_e := .0278 \quad \lambda := 1$$

$$R_{\text{rad}} := 160 \cdot \pi^2 \cdot \left(\frac{H_e}{\lambda} \right)^2$$

$$R_{\text{rad}} = 1.22$$

We can express this graphically in a chart, such as one found in the Antenna Engineering Handbook by Jasik:

Finding 10-degree height on the graph above, and following that line until we reach the crossing for

unity current ratio, we see the ~ 1.27 ohm radiation resistance is in agreement.

Notice that the number of vertical conductors does NOT enter into the equation! This is the absolute maximum possible radiation resistance we can obtain for a given radiator height.

Non-uniform Current

Radiation resistance is purely a function of the effective current distribution and height of the radiator, and is limited by height (spatial length)! Current throughout the antenna will not remain uniform if we reduce the size of the flat-top or hat.

Current will become zero at the very top with no hat, and 100% base loading. In this case, with no change in height, radiation resistance will be approximately 1/4th the value of the uniform current example. The result is exactly like a 50% reduction in effective element height.

If we follow the 10-degree line to the intersection point with 0 top current, we find radiation resistance to be around .32 ohms. 1.27 ohms, the radiation resistance for uniform current, becomes $1.27/4$ or .3175 ohms.

If we stay on the uniform current line, we find that .3175 ohms would be the radiation resistance of a 5-degree monopole with uniform current.

Efficiency

It often helps to look at the extremes, so we can get a feel for the effect of changes.

Let's look at the poor ground extreme and assume we have system losses, normalized to the current maximum, that are many times the radiation resistance. This would be the case for a short 160 or 80 meter mobile antenna.

In such a system radiation resistance would dominate any change that would affect efficiency. Current distribution would mean everything to efficiency.

Assume we have a base loading coil, either good or poor, and a thin mobile whip above the coil. Efficiency would increase by a factor of approximately four times by installing a capacitance hat with several times the distributed capacitance of antenna conductors below the hat.

Moving the coil would have little or no effect on efficiency.

A six-foot antenna with a large hat would be electrically equal to a 12-foot antenna without a hat.

This is why very poor inductors used on antennas in mobile shootouts, with large hats, equal or beat very large high-Q coils in similar height antennas that do not have large hats. One case in mind was a Hamstick lash-up in a mobile. The Hamstick, a notoriously poor efficiency antenna for 75-meters, soundly trounced Bugcatcher antennas when a large hat was added to the Hamstick.

Moving the coil up on the antenna has the effect of making current below the coil uniform, but without a hat current above the coil is a triangular taper that reaches zero at the element tip. The effective height of the area above the coil is 50% of actual height.

If we add a large hat at the bottom of the whip, current in the whip is actually reduced! At the same time, we change nothing below the coil. The effect of adding a large hat below the whip is to reduce the effective height of the antenna, when considered as a percentage of physical height. Radiation resistance and efficiency is generally reduced by adding a hat just above a coil, even if the hat allows us to use a smaller coil!

Adding a large hat at either end of a coil also reduces coil Q, since a large portion of the hat capacitance directly shunts the inductor.

Conclusion

We can reach the following conclusions:

- Radiation resistance, or at least the useful definition of radiation resistance, is limited by spatial area (or height in the case of a vertical) any antenna occupies.
- Radiation resistance is maximized by making current as large as possible over the entire spatial area of the antenna.
- Surrounding objects generally reduce radiation resistance and efficiency, even when they are NOT resonant, because they reduce effective height! This includes dielectrics that increase capacitance of the antenna to ground, since any increase in capacitance appearing well below the top of an antenna reduces effective height.
- Radiation comes from charge acceleration, nothing else. The longer the linear spatial distance we move charges in, the fewer charges we need to move at any point for the same amount of EM radiation. This is just another way of saying radiation resistance is higher in physically longer structures, especially when they carry uniform current.
- Any antenna (including Linear Loading, Helical Loading, Folded Monopoles, Fractal shapes, CFA, E-H, and so on) claiming to increase radiation resistance beyond the limits outline above is based on misunderstandings or untrue distortions of basic antenna principles.

1644

This page has been visited **1644** times since June 12, 2004

©2000-2004 W8JI



Messages

[Messages Help](#)

[Reply](#) | [Forward](#) | [View Source](#) |
[Unwrap Lines](#)

Message 37 of 706 | [Previous](#) | [Next](#) [[Up Thread](#)] [Message Index](#) Msg #

From: "exemptfromlife" <junkmail@a...>
Date: Tue Sep 9, 2003 10:54 pm
Subject: Slingshot method for hanging SkyWires.

Slingshot method for hanging SkyWires.

Guys,

In my youth (19 years old), fresh out of Marine Corps Boot Camp, I

would climb to the tops of trees like a monkey, while friends on the ground would yell "that's high enough!!" to put up

Owl

Nesting

boxes, etc.. What they didn't know was it was much easier that most of the stuff the Corps had me doing.

That was then and this is now. Now Walter no longer leaves the ground unless I have a boarding pass, and a coach ticket.

After reading a few articles I decided to try the slingshot

Find someone to fall in like with.

Erin and Jay

YAHOO! personals

I'm a:

Seeking a:

Age:

to

City or ZIP:

- [Home](#)
- [Messages](#)
- [Links](#)
- [Calendar](#)

Members Only

- [Chat](#)
- [Files](#)
- [Photos](#)
- [Database](#)
- [Members](#)
- [Promote](#)

method of
hanging a wire antenna.

Its Pretty easy.

You need the following items.

A fishing pole, a dozen 1 oz. Lead egg sinkers, a good
Crossman or
Wrist-Rocket slingshot, a large spool of Trout Line, Large
Nails,
a hammer, and a Fishing pole holder, if you can't find
someone
to
help.

I've seen ads in radio magazines for a slingshot-fishing reel
combo,
for \$100. If you have \$100 to blow, take you wife out to a
fancy
restaurant. I believe it's a much better investment that
this.

The
slingshot, and a fishing rod and reel will set you back about
\$30..

I use trout line because it is very strong, and given its to
be used
in water, its waterproof, and seems to hold up very well, and
is
cheap. But if someone knows of another rope that works
better, please
let me know.

You can find all of this at your local bait and tackle store.
I pay
about 20 cents for each egg sinker, I use egg sinkers because
they
are about as aerodynamic as fishing weights get, and because
the
shape doesn't allow them to get hung up in the tree branches
as
much
as others do, but it still happens.

I have heard of people using a Bow and Arrow. I can see some
advantage to this, but I think the risks outweigh the
benefits. With

a 1 oz. Egg sinker, you have to be careful it doesn't come down on a parked car's windshield, or dent the hood. With an Arrow, it could put a hole in someone's roof, or worse, if you neighbor or his kids are outside, they could end up impaled and looking like Gregory Peck in the last scene of the movie "The Omen". We don't want that...

When shooting the egg sinker, you want to be on the "Antenna side" of the tree.

Take the pole holder, and place it in the ground at an angle, facing the target tree. Put the fishing pole in the holder.

I have read that if you paint the egg sinkers blaze orange, you can see them better when they come down. I haven't tried this, but it makes sense. Having a florescent fishing line in your fishing reel helps in locating the downed egg sinker, but is not necessary.

If you are right handed, taking the slingshot in the left hand, and stand with the fishing pole to the right of you. If left handed, do the opposite. Place the egg sinker in the sling with the fishing line coming out of the top, and clear from the rubber bands.

Make sure not to stand too close to the tree, you want the egg sinker to clear the tree, and fall on the far side, if you are too close, you will be shooting at too high an angle and the egg sinker won't fall on the far side, but on the shooting side.

Shoot the egg sinker and pay attention to the direction of

where you
shoot, and see if you can judge where it should have landed
before
you walk over to the far side of the tree.

Then go find it. You may find that you need to take the
fishing pole
and "play" with the line a bit to get the egg sinker to fall
down to
ground level from the higher branches.

If it gets hung up, you will just have to reel it back and
start
over. I have about a 50/50 success rate.

Once I find the egg sinker, I cut it off, then tie the trout
line to
it and go back to the fishing pole and reel the trout line
back over
the top of the tree.

When the trout line reaches the pole, cut the line, and tie
your dog
bone insulator on to it.

Go back and cut the trout line from the trout line spool, and
take
two large nails and hammer each of them about half way into
the trunk
of the tree. The nails should be about a foot or so apart and
angled
away from each other forming a cleat.

I like to hammer the nails high enough that some kids don't
come
along and decide to undo my work. If this is a real concern,
you may
consider using a ladder and nail them higher up on the trunk
of the
tree. Plus, the higher up, generally the less visible it is
too.

Tie the trout line around one nail.

Repeat these steps on all the trees in your SkyWire system.

Once you run your antenna wire through the dog bone insulator

you can then begin to raise the antenna by taking the slack out of the trout line. Just begin wrapping the trout line around the both nails in a loop until the antenna reaches the desired height.

That's about it.

I am currently working on a fuse system that uses a bungee cord, and counter-weight, so that when bad weather hits, and high winds put too much pressure on the SkyWire, that the "fuse" will break causing about 20 feet of extra trout line to be unleashed, and letting the SkyWire fall limp, but not letting it break. This would allow you to easily recover the extra trout line, and put a new "fuse" back into the system after the storm passes.

Once I have the dynamics of this worked out, I will post it. (sometime this fall, I hope)..

Thanks,

Walter

<http://groups.yahoo.com/group/SkyWires/>

| | Replies | Name/Email | Yahoo! ID | Date |
|---|--|----------------------------------|----------------------------------|---------------|
| 38 | Re: Slingshot method for hanging SkyWires. | rickfrazier96720 | rickfrazier96720 | Tue 9/9/2003 |
| 40 | Re: Slingshot method for hanging SkyWires. | Clinton | ve7knl | Wed 9/10/2003 |
| Message 37 of 706 Previous Next [Up Thread] Message Index Msg # Reply Forward View Source Unwrap Lines | | | | |

Copyright © 2004 Yahoo! Inc. All rights reserved.

[Privacy Policy](#) - [Copyright Policy](#) - [Terms of Service](#) - [Guidelines](#) - [Help](#)

Traps

[[Home](#)] [[Up](#)]

This article is from a talk I gave about antenna traps. It contains measurements of traps, performance of trap antennas using models of traps, and ideas on how to make trap antennas more efficient.

Try taking this Trap-Q test! Be honest.

- 1.) **Is it best to make the trap resonant close to the desired operating frequency?**
- 2.) **Does bandwidth decrease with increasing trap Q?**
- 3.) **Do traps create noticeable loss, perhaps one dB per trap typically?**
- 4.) **Does higher trap operating Q always mean lower loss?**

Coaxial Trap Designer by VE6YP (Tony Fields)

Coaxial Trap Design

Design Parameters

Frequency: 7.040 MHz

Form Diameter: 3.5 inches

Coax Diameter: 0.195 inches

Capacitance: 26,000 pF/foot

Select coax cable type: Belden 9311 RG58 A/U

Units
 Metric
 British

Calculated: Turns: 5.42 L: 3.689 uH

Coil Length: 1.06 inches C: 138.54 pF

Coax Length: 63.94 inches X: 163.18 ohms

End Sensitivity: 54.41 kHz/inch

Turn Sensitivity: 147.29 kHz/inch

Length/Diameter: 0.29

Help Quit

This is a good program to get you in the ballpark with a trap design. It was available as freeware. (Unfortunately coaxial traps are relatively lossy on the trapped frequency

compared to other types.)

The software is available at <http://members.shaw.ca/ve6yp/index.html>

7.04 MHz 3.5 inch diameter form RG58/U into the VE6YP program yields calculated values of:

Calculated

Actual Measurement

L= 3.689μH

3.116μH

C= 138.5 pF

164 pF

64 inches

59 inches

Using the program TLA by N6BV (from ARRL), we would estimate capacitance of a 59' RG-58/U cable as:

R .22 -j143.61 or about 157 pF (Q=650)

Measuring a real-world stub, capacitance was 164pF (Q=590).

While that Q seems high, remember a typical transmitting-type air-variable capacitor has a Q of several thousand!

Coaxial Trap Articles and Programs use capacitance/ft multiplied times length....

26 pF * 4.917 feet = 127.84 pF in trap program

C164 pF measured. This error, 36pF low from 164pF, occurs because the transmission line making up the "coaxial capacitor" is not actually treated as a transmission line in the modeling program.

Fortunately the error is in a useful direction, because we can shorten the cable! Coaxial capacitors are really open stubs, and should be treated that way once they are more than a few degrees long.

CONCLUSION: The difference between TLA and an actual measurement was around 4%. This is very close, but the result has significant difference from the coaxial trap program since it only considers pF per foot as the capacitance. A longer cable (in fraction of a wavelength) results in greater error by using pF per foot. The error comes because a coaxial cable capacitor is really a stub, NOT a pure capacitor!!

Trap Measurements (at resonance)

| Type | F MHz | R parallel | X |
|--|--------------|-----------------------|----------|
| Coax RG-58 | 7.034 | 17,800 | 0 |
| UT-141-75 semi-rigid | 7.045 | 45,330 | 0 |
| 100pF 7.5kV & #12 wire | 7.040 | 99,850 | 0 |
| 60pF 15 kV & #10 wire | 7.040 | 250,000 | 0 |
| 60 pF vac & Copper tubing | 7.040 | 300,000 | 0 |
| Coax RG-58 | 3.700 | 23,200 | 0 |
| Coaxial with fixed mica capacitor | 7.040 | 21,660 | 0 |

Highest R parallel equivalent is best!! Lower Rp means more loss.

Trap Measurement summary:

- **Coaxial trap poorest**
- **Once #10AWG wire is used, not much improvement**
- **Space-wound bare wire makes best inductor**
- **Transmitting-type capacitors noticeably better than capacitors made from coax**

10 Meter (Tribander) Traps

| Type | Freq | R parallel | X |
|----------------------|--------------|-----------------------|----------|
| Coax RG-58 | 29.00 | 13,800 | 0 |
| Mosley TA-33 | 30.64 | 43,100 | 0 |
| Mosley Pro-57 | 27.46 | 66,080 | 0 |

| | | | |
|---------------------|--------------|----------------|----------|
| Cushcraft A3 | 28.78 | 110,000 | 0 |
| HyGain TH-3 | 29.67 | 140,200 | 0 |

Traps are not all that bad when you plug them into models.

15 Meter (Tribander) Traps

| Type | Freq | R parallel | X |
|---------------------|--------------|-----------------------|----------|
| Coax RG-58 | 21.00 | 13,980 | 0 |
| Cushcraft A3 | 21.43 | 76,270 | 0 |
| Mosley TA-33 | 21.68 | 79,000 | 0 |
| HyGain TH-6 | 22.23 | 142,000 | 0 |

Trap Model

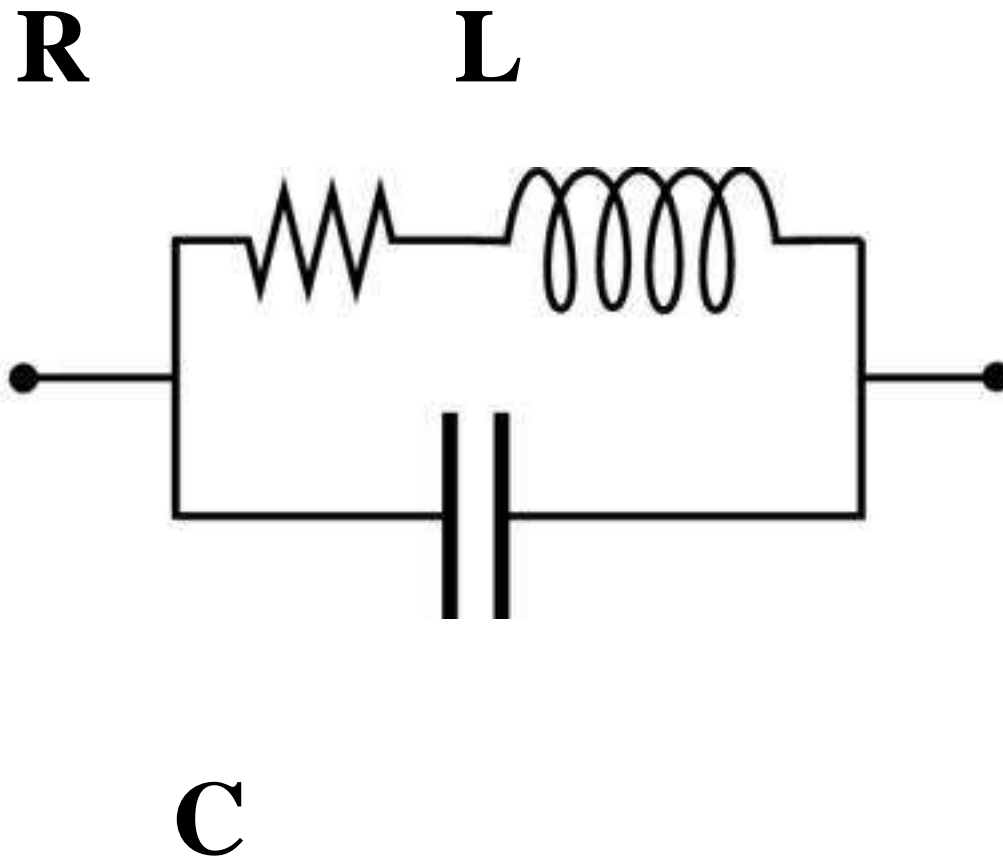

Measured Values Coax 7 MHz Trap

| Freq | Imp | R | Xc | Q | L uH | C pF |
|-------------|------------------|-------------|------------|------------|--------------|-------------|
| 7.04 | 17,800 j0 | 1.03 | 138 | 134 | 3.114 | 164 |

| | | | | | | | |
|------------|------------|-------------|-----------|------------|-----------|--------------|------------|
| 3.7 | 1.1 | j 97 | .6 | 283 | 88 | 3.114 | 152 |
|------------|------------|-------------|-----------|------------|-----------|--------------|------------|

Measured Values L/C 7 MHz Trap

| Freq | Imp | R | Xc | Q | L uH | C pF |
|-------------|-----------------------|------------|------------|------------|-----------------|-------------|
| 7.04 | 99,850 j0 | .36 | 215 | 465 | 4.92 | 105 |
| 3.7 | 0.53 j 156 | .25 | 409 | 294 | 4.92 | 105 |

SWR Bandwidth

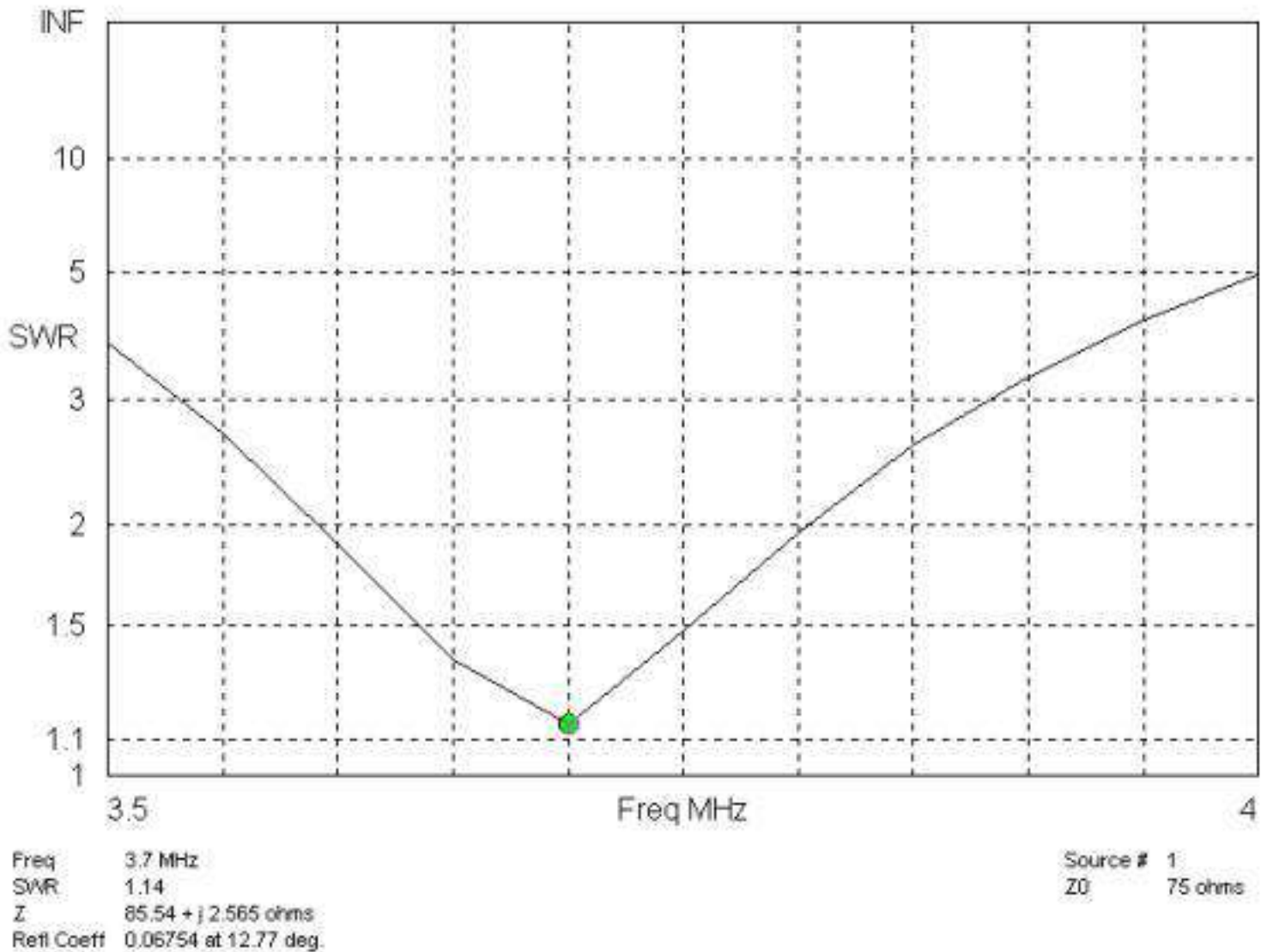

7 MHz RG-58 TRAP

80 m 75 ohm VSWR

EZNEC #12AWG dipole

Coax trap 80m 2:1 VSWR ~210 kHz

Total trap loss = 0.05 dB

RG-58 TRAP, 75 ohm VSWR, 40 METERS

VSWR BW

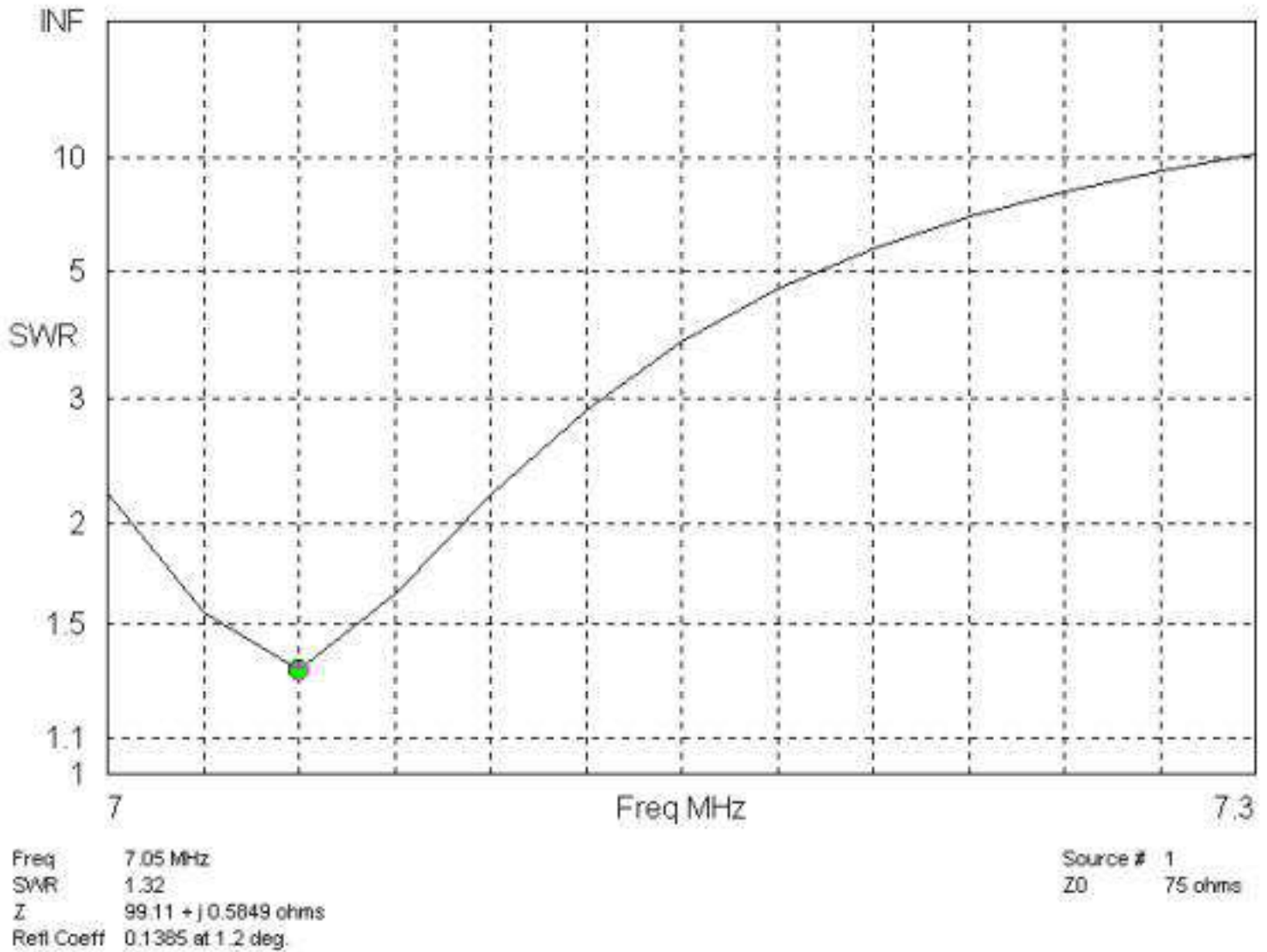

Coax trap 40 meter 2:1 VSWR ~ 80 kHz

Total coaxial trap loss at resonance on 40m= 1.6 dB

Total coaxial trap loss 100kHz off-resonance (at 7.15 MHz)= 1.06 dB

Note that loss is maximum at trap resonance!!!

Never make a trap resonant on the desired operating frequency!!

W2LH ARRL Handbook Trap Design

100pF #12awg Miniductor trap

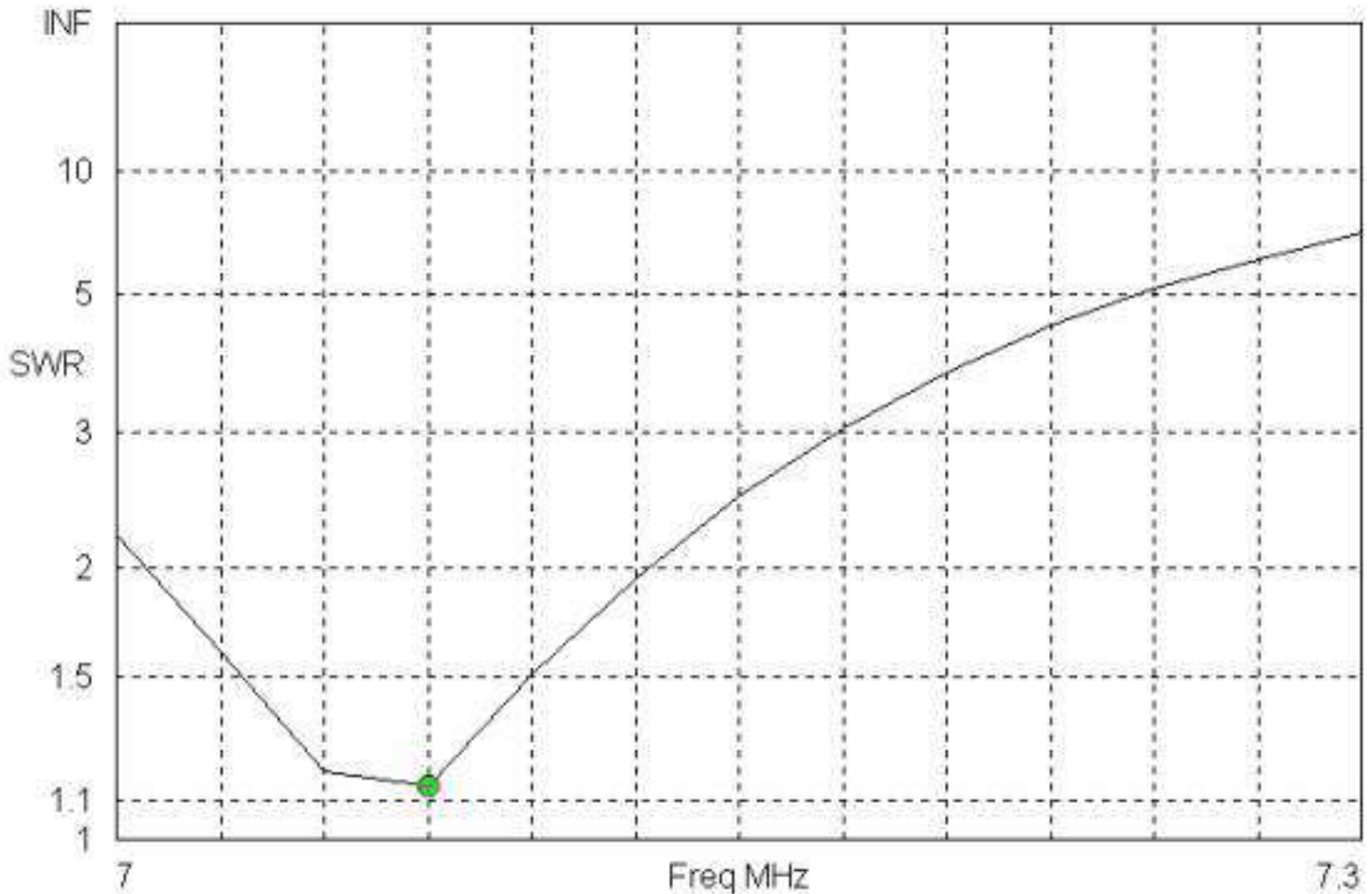

Freq 7.075 MHz
 SWR 1.14
 Z 77.73 + j 9.703 ohms
 Refl Coeff 0.06587 at 70.64 deg.

Source # 1
 Z0 75 ohms

40m 2:1 VSWR ~120 kHz

Total loss = 0.24 dB

W2LH ARRL HANDBOOK TRAP 80m

VSWR

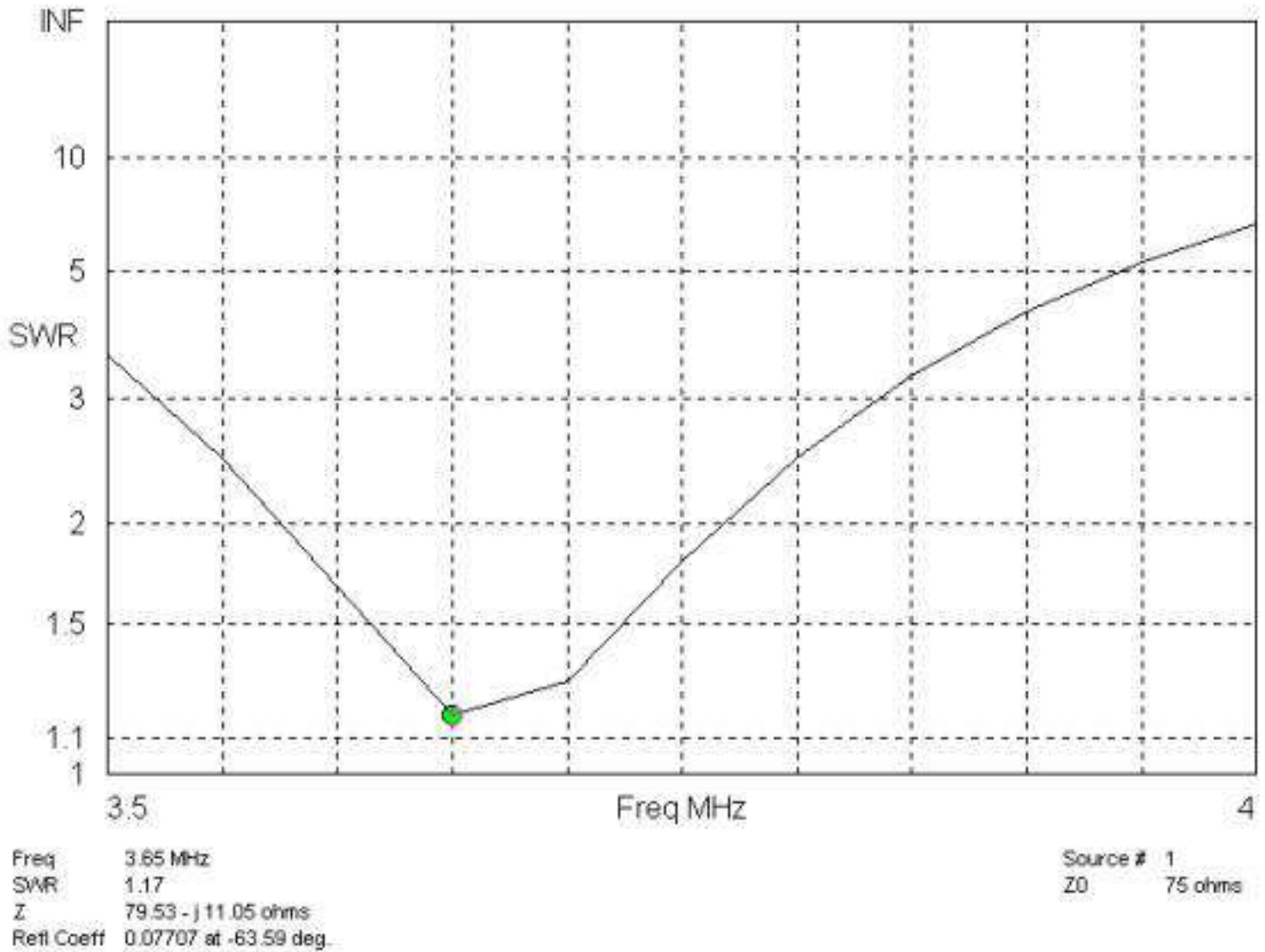

80m 2:1 VSWR BW ~ 200 kHz

Total trap loss = 0.026 dB

What happens if trap is not in band?

VSWR Bandwidth of 6.51MHz trap in 80/40 dipole

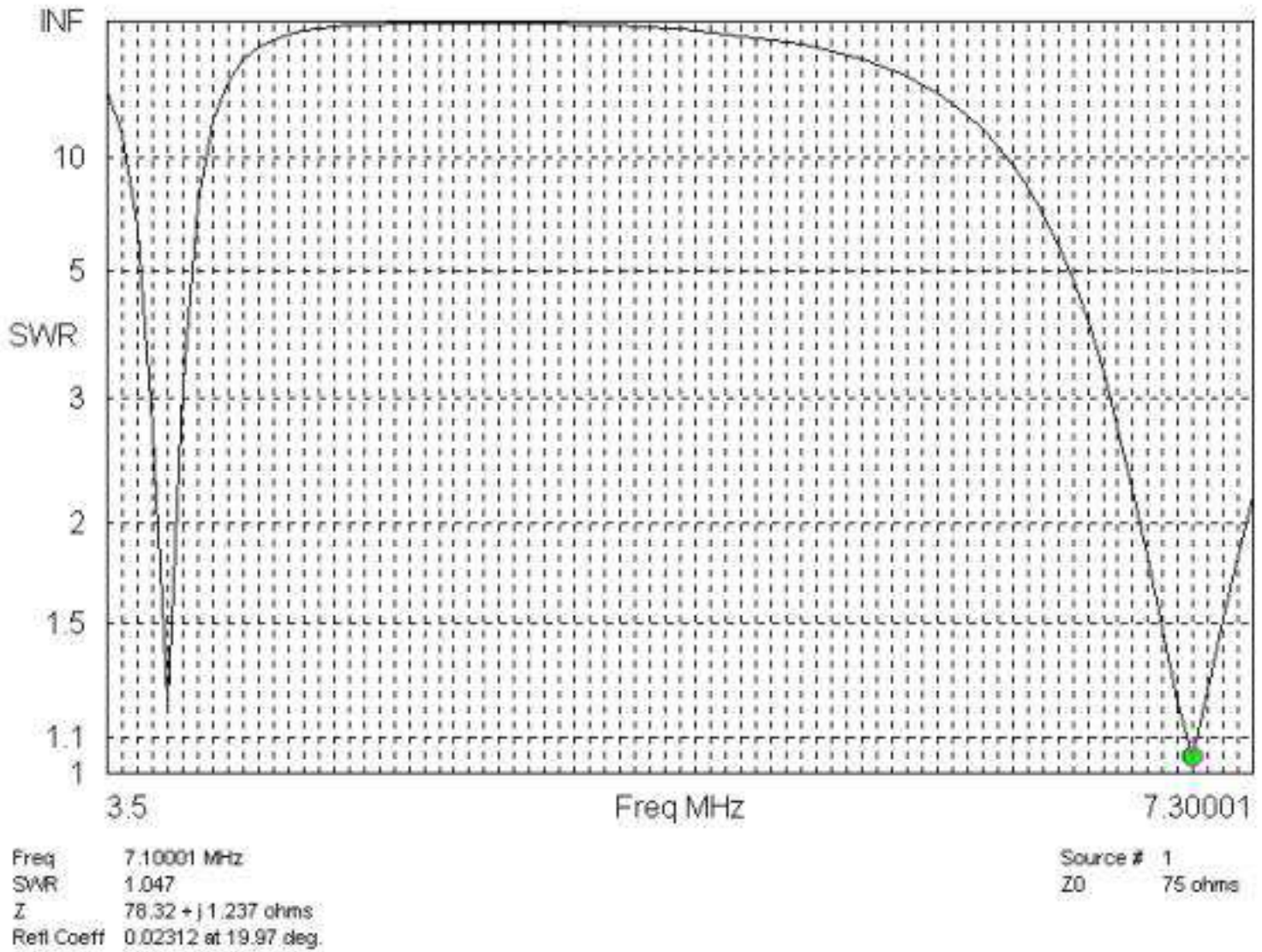

Trap at 6.51 MHz $Q=130$

Loss at 7.15 MHz = 0.314 dB

Loss at 3.7 MHz = 0.324 dB

This is a 104-foot long antenna, with very poor Q traps, and loss is less than .4dB! The reason loss is low is we have moved the trap slightly out-of-band.

6.15 MHz $Q=130$ TRAP 40m VSWR

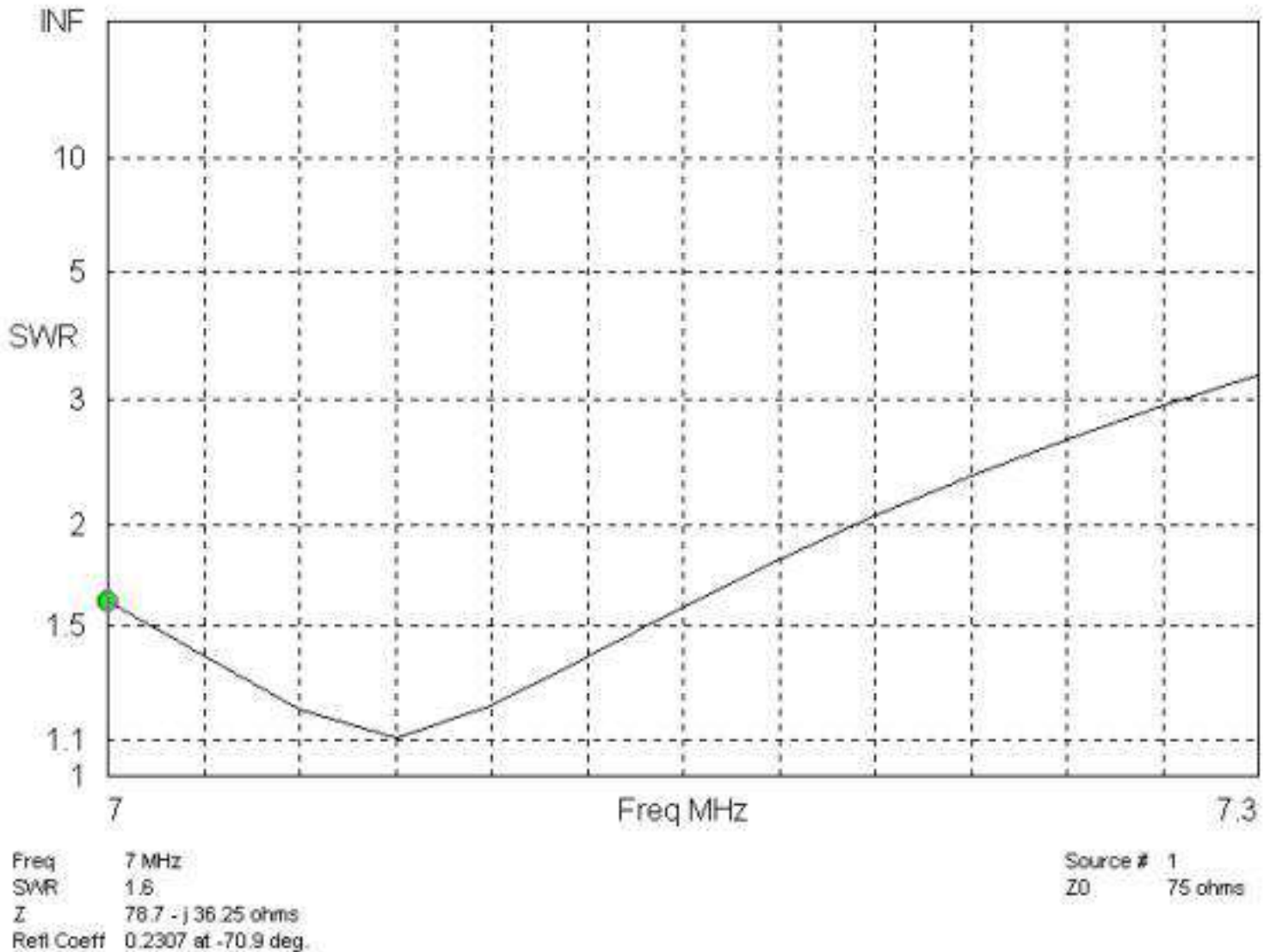

7 MHz 2:1 VSWR BANDWIDTH ~200kHz

Trap Q at resonance = 130 7 MHz loss ~ .3 dB

6.15 MHz Q=130 TRAP 80m VSWR

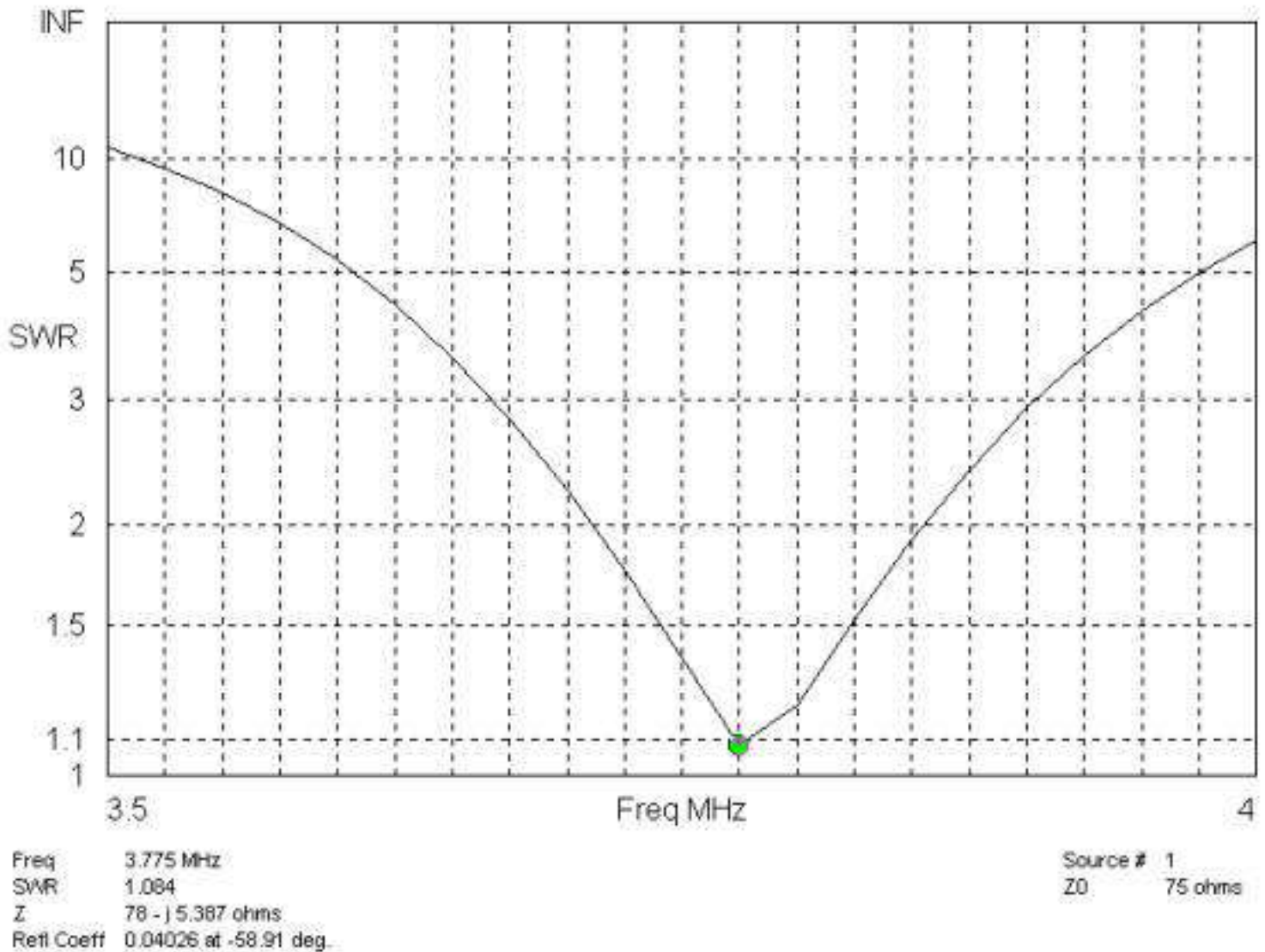

80M 2:1 VSWR BW ~130 kHz

Loss at 3.7 MHz = 0.324 dB

1.) **Is it best to make the trap resonant close to the desired operating frequency?**

NO! Loss is highest when the trap is resonant at the operating frequency!

2.) **Does bandwidth decrease with increasing trap Q?**

NO! Bandwidth is a function of many variables, trap Q actually has one of the smallest influences on BW.

3.) Do traps create noticeable loss, perhaps one dB per trap typically?

NO! Even the worse traps (coaxial traps) in the worse possible condition of operation are only 1.6dB loss for BOTH traps!

4.) Does higher trap operating Q always mean lower loss?

NO! Loss depends on many factors, including trap resonant frequency.

Conclusions:

- Trap loss has been greatly exaggerated by advertising hype
- Traps should not be resonant at the actual planned operating frequency
- Coaxial traps are more lossy than articles conclude
- Coaxial stubs used as capacitors can not be calculated using pF/ft unless the stub is a very small fraction of a wavelength long (less than a few electrical degrees)
- Coaxial stubs have low Q (are relatively lossy) compared to normal lumped components.

Aerials and Trees

[[Home](#)] [[Up](#)]

Click [HERE](#) for the [Amazing Online Ham Radio Flea Market](#)



[6.7m fibreglass poles for sale](#)
[click](#)

[***HERE***](#)

From time to time we all need to get wires or lines over trees to support aerials. With a small tree of say 5-7 metres high it is quite easy just to throw a weighted line over the top. But what if the tree is larger?

Over the years I have tried quite a few ways but the best by far has been the use of a catapult - suggested to me by Dave G3YXM who also uses a bow and arrow! Catapults can be bought from fishing shops and are used to throw ground bait. Look for a high power model and for maximum accuracy and power, choose one with an arm brace (see picture below). But don't leave the fishing shop just yet as you will need some more things. First get a cheap casting reel. They are often available for about £5. This needs to be fastened on to the catapult. I used some cable ties. The casting reel ensures that the line flows freely. Laying the line on the ground generally fails as it gets caught or tangled. For line, you need to choose something thin and light - this line will not be used to support the aerial, it is just to get it over the tree. Use 12-15 pound breaking-strain monofilament. You will also need a weight to fire. I use a 2 oz sinker. I paint them orange to make them easier to see in trees! Tie the weight on to the line using the special knot that works with monofilament (called a blood knot I think). This knot is described in fishing books. I have also had success with a figure-of-eight knot.

Search G3CWI's site

Now you are all set. Safety must be your first consideration. Make sure that the area around the tree is clear of any people, animals, overhead electricity cables and anything else that could either endanger you or could be in danger from your efforts. Fire the weight aiming well clear of the top of the tree, an angle of between 45 degrees and 60 degrees to the horizontal seems best. If all is well the line should pay out cleanly but generally the weight will not reach the ground. Gently pull on the line several times, letting the weight drop further each time. Then go and see if you can find it. The paint helps here! If you fail to get it in the right place, you have two choices, either cut the line and let the weight drop or try to pull it back. If you do try to pull it back be very careful as the weight can easily fly out of the tree in your direction as you pull on the stretchy monofilament.



If all is well and the weight has reached the ground in the right spot, then cut the weight off the line and tie on a thicker line that will be used to support the aerial. I use 40 pound or 100 pound monofilament. Pull this line back through the tree, tie on the aerial, pull it up and you're on the air. I have used this method successfully with trees up to 90 feet tall (27 metres).



The G3CWI Catapult in action

[[Home](#)]

PDF download section - Manuals, Parts Lists, Brochures, Reviews, Technical Notes



Please select a section to view PDF files.

[Beam Antennas](#)

[Articles](#)

[Beam Antenna Accessories](#)

[Parts List](#)

[Vertical Antennas](#)

[Tech Notes](#)

[Vertical Antenna Accessories](#)

In order to view PDF files you need the free Acrobat Reader from Adobe.

Download Acrobat Reader by clicking on the icon



Description

File Name SizeKB

Beam Antennas

[Model 10/11, Butterfly beam antenna covering 10 or 11 meters produced from 1987 to Present](#)

00246IZV 81

Model HF3B, Butterfly beam antenna covering 10, 15 and 20 meters produced from 1998 to Present

00761IZV

[Model HF3B/HF4B, Butterfly beam antenna covering 10,12, 15 and 20 meters produced from 1985 to 1985](#)

00703IZV 575

[Model HF4B REV A, Butterfly beam antenna covering 10,12, 15 and 20 meters produced from 1985 to 1986](#)

00402IZV 566

[Model HF4B REV B, Butterfly beam antenna covering 10,12, 15 and 20 meters produced from 1986 to 1987](#)

00704IZV 1,032

[Model HF5B, Butterfly beam antenna covering 10, 12,15, 17 and 20 meters produced from 1987 to 1988](#)

00706IZV 766

[Model HF5B REV A, Butterfly beam antenna covering 10,12, 15, 17 and 20 meters produced from 1988 to 1991](#)

00810IZV 847

[Model HF5B REV B, Butterfly beam antenna covering 10,12, 15, 17 and 20 meters produced from 1991 to 1995](#)

00705IZV 1,013

[Model HF5B REV C, Butterfly beam antenna covering 10,12, 15, 17 and 20 meters produced from 1995 to Present](#)

00159IZV 123

Beam Antenna Accessories[top](#)

[Model 18MCA, 17 meter kit for the HF3B or HF4B Butterfly beam produced from 1987 to Present](#) 00370IZV 18

[Model 24MCA-II, 12 meter kit for the HF3B Butterfly beam produced from 1985 to Present](#) 00373IZV 16

Vertical Antennas[top](#)

[Model 2MCV, VHF collinear vertical covering 2 meters, 3 dB gain produced from 1978 to 1994](#) 00243IZV 191

[Model 2MCV-5, VHF collinear vertical covering 2 meters, 5 dB gain produced from 1984 to 1994](#) 00244IZV 123

[Model HF2V, HF Vertical antenna covering 40 and 80 meters produced from 1984 to Present](#) 00156IZV 77

[Model HF4V-II, HF Vertical antenna covering 10, 15, 20, and 40 meters produced from 1978 to 1981](#) 00409IZV 188

[Model HF4V-S, HF Vertical antenna covering 10, 15, 20, and 40 meters - 14 ft produced from 1978 to 1981](#) 00811IZV 235

[Model HF5V, HF Vertical antenna covering 10, 15, 20, 40 and 80 meters produced from 1974 to 1977](#) 00812IZV 179

[Model HF5V-II, HF Vertical antenna covering 10, 15, 20, 40 and 80 meters produced from 1977 to 1979](#) 00813IZV 379

[Model HF5V-III, HF Vertical antenna covering 10, 15, 20, 40 and 80 meters produced from 1979 to 1981](#) 00464IZV 306

[Model HF5V-S, HF Vertical antenna covering 10, 15, 20, 40 and 80 meters - 16 ft produced from 1978 to 1981](#) 00463IZV 205

[Model HF6V, HF Vertical antenna covering 10, 15, 20, 30, 40 and 80 meters produced from 1981 to Present](#) 00366IZV 91

[Model HF6V-X, HF Vertical antenna covering 10, 15, 20, 30, 40 and 80 meters produced from 1987 to 1997](#) 00233IZV 132

[Model HF9V, HF Vertical antenna covering 10, 12, 15, 17, 20, 30, 40 and 80 meters produced from 1997 to Present Model](#) 00408IZV 115

[Model HF9V-X, HF Vertical antenna covering 10, 15, 20, 30, 40 and 80 meters produced from 1989 to 1997](#) 00233IZV 132
00234IZV 18
00235IZV 19

| | | |
|--|----------|---------------------|
| Model SC-3000, Collinear vertical scanner antenna covering 30-512 MHz produced from 1984 to 1995 | 00245IZV | 68 |
| Model SC-5000, Collinear vertical scanner antenna covering 30-905 MHz produced from 1985 to 1995 | 00819IZV | 63 |
| Vertical Antenna Accessories | | top |
| Model 30MRK, 30 meter kit for the HF2V produced from 1985 to Present | 00241IZV | 17 |
| Model A-17-12, 12 and 17 meter kit for vertical antennas except HF2V produced from 1989 to Present | 00234IZV | 18 |
| Model A-18-24, 12 and 17 meter kit for vertical antennas except HF2V produced from 1983 to 1989 | 00820IZV | 114 |
| Model A-6, 6 meter kit for vertical antennas except HF2V produced from 1987 to Present | 00235IZV | 19 |
| Model CPK, Capacitive counterpoise kit for HF6V through HF9V vertical antennas produced from 1993 to Present | 00236IZV | 40 |
| Model GRK, Ground radial kit for all vertical antennas produced from 1988 to Present | 00404IZV | 34 |
| Model RMK-II, Roof mounting kit for HF6V through HF9V vertical antennas produced from 1982 to Present | 00240IZV | 28 |
| Model STR-II, Stub tunned radial kit for HF6V through HF9V vertical antennas produced from 1982 to Present | 00239IZV | 16 |
| Model T-2, 2 ft Tripod tower produced from 1982 to Present | 00247IZV | 18 |
| Model TBR-160, Top band resonator kit (160 meters) for all vertical antennas produced from 1979 to 1981 | 00821IZV | 147 |
| Model TBR-160-HD, Top band resonator kit (160 meters) for all vertical antennas produced from 1981 to 1987 | 00822IZV | 147 |
| Model TBR-160-S, Top band resonator kit (160 meters) for all vertical antennas produced from 1987 to Present | 00237IZV | 26 |
| Model TBR-160-S-NK, Neutralizing kit for the TBR-160-S produced from 1987 to Present | 00238IZV | 7 |
| Model TLK, Top loading kit for the HF2V produced from 1984 to Present | 00242IZV | 9 |
| Articles | | top |
| Vertical Antennas, Ad Hype And Technobabble | 00815ZZV | 23 |
| Whither Vertical Antenna Design? | 00816ZZV | 24 |

Parts Lists

[top](#)

| | | |
|------------------------|----------|----|
| HF2V | 00768ZZV | 16 |
| HF5B | 00809ZZV | 12 |
| HF6V | 00648ZZV | 20 |
| HF6V-X | 00647ZZV | 21 |
| HF9V | 00649ZZV | 24 |

Tech Notes

[top](#)

| | | |
|--|----------|----|
| Dirty Little Secrets | 00363ZZV | 27 |
| Dirty Little Secrets 2 | 00804ZZV | 27 |
| Ground/Radial Systems | 00361ZZV | 43 |
| Phased Arrays of Short Vertical Antennas | 00362ZZV | 9 |
| Why Radials? | 00803ZZV | 41 |

Please select antennas from the pop-up menu below



[Find a dealer near you!](#)

[Camera Equipment](#) | [Amateur Radio Equipment](#) | [Contacting Bencher](#)

Copyright Bencher, Inc. 1997-99

Any questions about the information on this site should be emailed to bencher@bencher.com

Santa Clara County, California

ARES/RACES

EMERGENCY OPERATIONS & YOUR HT

Before I begin, I would like to give credit to C. Edward Harris, KE4SKY, AEC for Fairfax County ARES in Virginia for his article on "Getting the most from your Hand Held Transceiver." Much of this script has been taken from that article. Some minor editorial changes have been made to make it more readable over the air.

<PAUSE for the Repeater to reset >

HT Antennas

It shouldn't come as a surprise to anyone that when limited to "barefoot" operation with a "rubber duck" on simplex, HTs are not adequate as a primary rig for emergency communications. The National Institute of Standards and Technology (NIST) ran some tests (back when they were still the NBS) on Public Safety high band and amateur 2-meter antennas. They found that a "rubber duck" has -5db gain compared to a quarter wave antenna held at shoulder height. In terms of effective radiated power (ERP), a 5w HT with rubber duck antenna, held at shoulder height would actually radiate 1.5 watts. Placing the HT on your belt attenuates the signal another 20db, reducing ERP to only 15 milliwatts! UHF results weren't found to be much better.

<PAUSE for the Repeater to reset >

A simple and inexpensive improvement that can be made to the "rubber duck" is the addition of what is called a "tiger tail". You can make one of these using a quarter-wavelength (19-1/4" for 2 meters) piece of #14 through #20 stranded wire, crimped and soldered to a battery clip. Reinforce the soldered connection with heat shrink tubing or tape to resist flex. Clamped to the outer collar of the BNC connector on your HT antenna, it acts as a counterpoise so that RF from the HT doesn't couple with your body. A "tiger tail" is directional and can be used to change both radiation angle and direction. It gives best simplex performance when pointed in the general direction of the station you are trying to "hit".

<PAUSE for the Repeater to reset >

Almost any antenna works better than the "rubber duck" that comes with an HT. A

flexible 1/4 wave or telescoping half-wave antenna are both improvements. A 1/4-wave used at shoulder height with a counterpoise has "unity" gain, which is a 5 db improvement over a rubber duck, because most of the signal is radiated. Using an HT at 5 watts with a 1/4 wave mag mount on an improvised ground plane, or telescoping half wave with a "tiger tail" improves simplex readability even further.

<PAUSE for the Repeater to reset >

In marginal locations, a telescoping half-wave is a good performer. A half wave used without a ground plane has the same unity gain as a 1/4 wave when used with a ground plane. Adding an effective ground plane or counterpoise to a half- wave produces roughly 2 db of gain. A telescoping half wave can also be attached to a coax jumper and pulled into a tree, dangled out a window, attached to a window pane with suction cups or used with a window clip door mount.

<PAUSE for the Repeater to reset >

Telescoping antennas work best when operating stationary or in the open, avoiding side impacts or rough handling. Extend and retract the radiating elements very carefully. If you note any wobbling or looseness, replace the telescoping radiator, if possible, or replace the entire antenna. Keep a close watch on your HT's connector also. It can become loose after extended use of a telescoping antenna.

<PAUSE for the Repeater to reset >

Flexible antennas are safer when working in close quarters around people and are more durable when walking through dense vegetation during search and rescue operations. They are a good choice for dual-band transceivers, but are usually optimized for one band and merely "acceptable" on the other. Most approximate a 1/4 wave on 2 meters and a 5/8 wave on 70 cm. How efficient a particular antenna is can be determined only by controlled testing.

<PAUSE for the Repeater to reset >

If you want to buy one emergency HT antenna, without risk or experimentation, the telescoping half-wave, flexible 5/8 wave or quarter wave mag mount all offer the best "bang for the buck" in my opinion. A telescoping half-wave boosts practical simplex range of a 5 watt, 2-meter HT from several miles with a rubber duck to many miles over suburban terrain. Adding a tiger tail further extends readable simplex range under the same conditions.

<PAUSE for the Repeater to reset >

Whatever antenna you choose, try to find one that is rated for at least 25W so that it can also serve as an emergency antenna for the HT with a power amplifier at medium power. A $\frac{1}{4}$ wave mag mount connected to a power amplifier works best on a car, but a suitable improvised ground plane can usually be found around the home or office. A metal filing cabinet, rain gutter, refrigerator, balcony railing or other large metal object may work just as well. If all else fails, place aluminum foil over a large piece of cardboard .

<PAUSE for the Repeater to reset >

A good possibility for Fixed position Emergency Operations is the so-called Roll Up J-pole . It's made from 300 Ohm TV Twin-lead and should give you several dB of gain over a rubber duck. I've used mine for the past year and one-half as a base antenna and have been quite happy with it. It is well worth the money spent (~ \$20). Let me reset and I'll give the dimensions.

<PAUSE for the Repeater to reset >

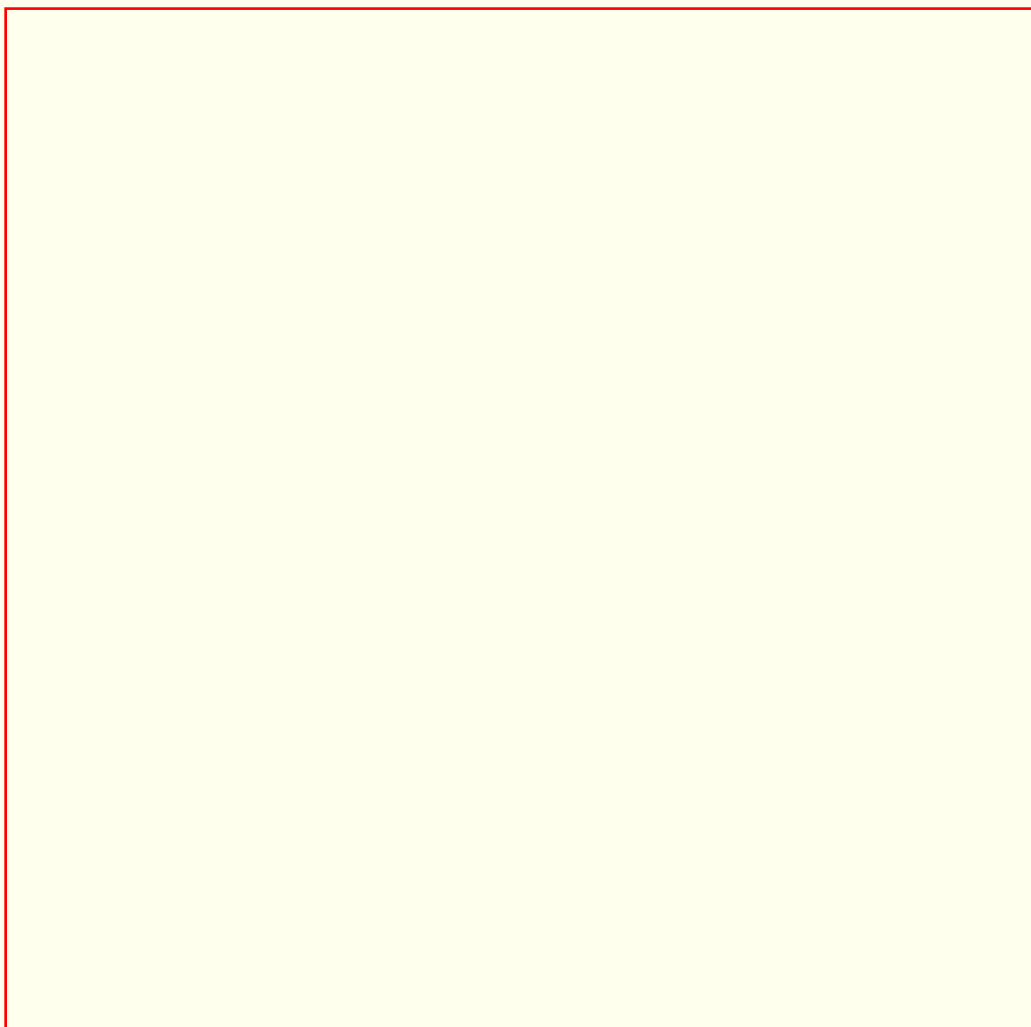

<PAUSE for the Repeater to reset >

Would anyone like any of the dimensions repeated?

<PAUSE for the Repeater to reset >

Another antenna that is a good performer for fixed operations is the "American Legion J-Pole". They are generally available at both the Foothill and Livermore Flea Markets for a reasonable price. Attach it to the top of a 10 foot section of PVC pipe and mount this to a camera tripod. Attach weights to the legs for stability. This makes a very nice fixed station antenna with good gain.

<PAUSE for the Repeater to reset >

BATTERY BASICS

For Emergency Operations, it is highly recommended that you carry two fully charged nicad packs and an extra AA battery case and batteries. The nicads will power your HT for at least the first full day of operations and the AA's will allow you to continue to operate if you can't recharge your nicads. It's also important in cold weather to keep nicads warm, and not exposed on your belt.

<PAUSE for the Repeater to reset >

As an alternate or primary power source, use 12-volt, 2 Ahr or higher Sealed Lead-Acid or Gel Cell batteries. They fit in a coat pocket, run an HT all day or power a 2 meter mini-amp for 3 hours at a typical duty cycle. Sealed Lead-Acid or Gel Cell batteries have many advantages. They will allow you to:

- Operate when other forms of power are not available
- Operate longer than with NiCad or Alkaline batteries; 1-3 Ahr batteries are still small enough to be hand carried.
- Operate mobile, portable or fixed at a higher output power
- Operate at a lower cost; Gel Cells and SLA's are less expensive than NiCads or alkalines.
- Operate with fully charged batteries at all times; It's possible to keep these batteries on a "smart" charger continuously.

<PAUSE for the Repeater to reset >

Sealed Lead-Acid batteries are used to power medical diagnostic instruments, alarm systems and Un-interruptible Power Supplies (UPA) just to name a few. Depending on the criticality of the application, some organizations replace their batteries on a regularly scheduled basis well before they are worn out and require disposal as hazardous waste. EC's should write or call local hospitals, explaining how batteries they discard are useful for emergency communications activity. It may be possible to obtain a quantity free for the asking, with no more trouble than signing a hand receipt to satisfy the environmental officer and writing a thank you letter to the hospital administrator. Remember, a hospital's "donation" to your ARES group eliminates their disposal cost.

<PAUSE for the Repeater to reset >

Besides hospitals, and alarm companies, batteries are also available locally at reasonable prices. For example, Halted Specialties usually carries new 12V, 7Ahr batteries for around \$20. For those wanting to buy a complete commercial package, HRO sells the "Hot Pocket" which is a 12V, 2Ahr SLA for \$78. It comes with its own pouch for attaching to your belt and a wall charger.

<PAUSE for the Repeater to reset >

If you decide to use Sealed Lead-Acid or Gel Cell batteries, you'll need a battery charger. 12 V Battery Chargers are available from various sources:

- Jade Products offers a "Smart Charger" for charging Gel Cells and SLA's. It's \$126.95 in kit form.
- A & A Engineering also offers a "Smart Charger" for Gel Cells and Lead-Acid batteries. Their charger is \$59.95 in kit form or \$79.95 finished.

You can also use so-called "Wall Warts", but the general consensus is that your batteries won't last as long on these inexpensive chargers.

<PAUSE for the Repeater to reset >

Of course, you can always build you own. Two very good articles are the:

June '87 issue of QST entitled "A New Chip for Charging Gelled-Electrolyte Batteries"

This article uses the Unitrode UC3906 "Smart Chip".

March '94 issue of QST entitled "A Lead-Acid Battery Charger"

There is also some very good information available on the internet. I have several good URL's that I can pass along if anyone is interested.

<PAUSE for the Repeater to reset >

<http://www.unitrode.com>

Unitrode – Home of the UC3906 "Smart Chip"

<http://www.benchmarq.com/>

Benchmarq chargers

<http://www.ibexmfg.com/>

Ibex battery chargers

<http://www.yuasabatteries.com/>

Yuasa "Battery Handbook and Technical Guide"

<http://www.electricti.com/batteri/pwrson1v.html>

Powersonic batteries

<PAUSE for the Repeater to reset >

AUXILIARY CONNECTIONS

Power cords for connecting to automobile cigarette lighter plugs or gel cell batteries will be needed for extended operation. Be aware that cigarette lighter plug power may be unreliable due to contaminated cigarette lighter sockets. Also, the sockets themselves vary in size, allowing the plug to vibrate loose. As an alternate source of power, however, everyone should still have the capability since they are readily available.

<PAUSE for the Repeater to reset >

Be sure to assemble any auxiliary power cords for your HT or small power amps following the standard wiring configuration shown in your respective SPECS or SVECS manual. The configuration that follows is taken from the ARRL ARES Resource Manual. The SVECS manual agrees with this configuration; I'm not certain of the SPECS manual. This configuration uses twin lead 12 to 16 gauge "zipline" with Molex Series 1545, 2-pin polarized connectors and .093 diameter pins. In ARES practice, the

female pins are assembled into the male plug which is attached to the power source, and the male pins into the female receptacle which is attached to the rig. This description will make more sense to you when you have the parts in front of you and are assembling the connector.

<PAUSE for the Repeater to reset >

The plug, receptacle and pin sets are available from Radio Shack, Part No. 274-222 and are rated at 12 amps, which is adequate to power small amplifiers up to 50w output. Wiring is simple. The end of the two-pin Molex plug in cross section resembles a little 2-story house with peaked roof. Remember proper polarity by using the word associations "red roof" and "black basement" for the positive and negative terminals respectively. Crimp the wires in place before soldering to ensure a strong connection. After inserting the pins into the plug and receptacle, check the fit of the assembled fitting and reinforce the wires behind the plug and receptacle with heat shrink tubing or tape.

<PAUSE for the Repeater to reset >

For re-charging the battery, attach crimp type .187" female tab terminals to fit the male tabs on the battery. The other end of the battery connection will go to a standard cigarette lighter socket. Next, wire a plug onto the leads of a 12-15v, 500 to 900mah charger. A depleted battery can be restored in 4 to 6 hours by plugging it into your car's battery. Gel cells and SLA's larger than 5 Ahr may be left on a 12-14V DC "smart" charger of 1 amp without harm. A word of caution here become very familiar with your particular charger and the types of batteries that you intend to charge before leaving a charging battery unattended. A malfunctioning charger can create a very BIG mess very quickly.

<PAUSE for the Repeater to reset >

HAND HELD DUTY CYCLE LIMITS

If you subject compact HTs to frequent full power 5w transmissions of several minutes duration they will overheat and the final power transistors may fail prematurely. Kenwood and Yaesu state in their service manuals that their HTs are rated for 20% duty cycle at maximum RF output, or 30 seconds of transmit to 2 minutes of standby.

<PAUSE for the Repeater to reset >

Of the popular 2-meter HT's, Standard does not restrict duty cycle on theirs, rating their amateur hand helds equal in that respect to their aviation, marine, commercial and public safety portables. Unless your HT is a Standard, older Icom or converted

commercial gear, it is best to use your HT mostly on medium or low power for long winded rag chews and restrict full power 5w use to short transmissions to save the finals. If you have a need for high power transmissions of several minutes duration and can't replace or supplement your hand held with a mobile rig, I would advise getting a power amplifier to do the heavy work. Just remember to reduce your HT's output power going into the amplifier, otherwise, you will still burn up your finals.

<PAUSE for the Repeater to reset >

ADVICE ON POWER AMPLIFIERS

An excellent way for HT owners to upgrade their portable ARES/RACES equipment is to purchase a power amp. An ideal amp should weigh less than 1 pound, be capable of 10 to 15w output when driven by an HT at 1w, or 20 to 40w output when driven by the same HT at 2 to 3w output. It should draw no more than 8 amps of current at its maximum rated output, enabling it to operate safely from the .093 diameter pin Molex Series 1545 connector or fused cigarette lighter plug.

<PAUSE for the Repeater to reset >

An FM-only amplifier without a preamp will be adequate in most cases. A preamp tends to accentuate intermod due to paging transmitters. Unless you equip your portable station with a notch filter and/or cavity bandpass to suppress this intermod, the preamp will serve no useful purpose. Be wary of bargain "no-name" amps you see at hamfests or in discount catalogs. Some are not aligned for the entire U.S. 2-meter band, many lack thermal protection circuitry for over voltage, overdrive or high VWSR or simply have an inadequate heat sink and will overheat and quit.

<PAUSE for the Repeater to reset >

OK, this concludes "Emergency Operations and your HT." Are there any questions?

[Web Site Home Page](#)

This page was last updated 04/21/02

The Effects of VSWR on Transmitted Power

By James G. Lee, W6VAT

No matter how long you have been a ham, sooner or later you will be involved in at least one discussion of something called the Voltage Standing Wave Ratio, or VSWR, of an antenna system. There is a lot of good information available on VSWR as well as a lot of misconceptions about what it is and what it signifies. Probably the most often misconception is that your VSWR should be as close to 1:1 as possible, otherwise "you won't get out very well." A 1:1 VSWR implies a perfect match between all elements of the antenna system. The only problem is that it is possible to have a low VSWR and still have some very serious things wrong with your antenna system. Other misconceptions such as a high VSWR causing television interference, or other unwanted problems are often heard and can cause unnecessary worry. The concept of VSWR is easy to grasp and its importance in an antenna system does not require an engineering degree to understand.

WHY VSWR EXISTS

Early in electronics you learned that to get maximum power into a load required that the load impedance match the generator impedance. Any difference, or mismatching, of these impedance would not produce maximum power transfer. This is true of antennas and transmitters as well but, except for handie-talkies, most antennas are not connected directly to a transmitter. The antenna is usually located some distance from the transmitter and requires a feedline to transfer power between the two. If the feedline has no loss, and matches BOTH the transmitter output impedance AND the antenna input impedance, then - and only - then will maximum power be delivered to the antenna. In this case the VSWR will be 1:1 and the voltage and current will be constant over the whole length of the feedline. Any deviation from this situation will cause a "standing wave" of voltage and current to exist on the line.

There are a number of ways VSWR or its effects can be described and measured. Different terms such as reflection coefficient, return loss, reflected power, and transmitted power loss are but a few. They are not difficult concepts to understand, since in most instances they are different ways of saying the same thing. The proportion of incident (or forward) power which is reflected back toward the transmitter by a mismatched antenna is called reflected power and is determined by the reflection coefficient at the antenna. The reflection coefficient "p" is simply a measure of this mismatch seen at the antenna by the feedline and is equal to:

$$P = (Z_1 - Z_0) / (Z_1 + Z_0)$$

Here Z_1 is the antenna impedance and Z_0 is the feedline impedance. Both Z_1 and Z_0 are complex numbers so "p" is also a complex number.

You remember from elementary AC mathematics that a complex number has a "phase angle" associated with it. The phase of the reflected signal will be advanced or delayed depending upon whether the antenna appears inductive or capacitive to the feedline. If the antenna appears inductive the voltage will be advanced in phase, and if the antenna is capacitive, the voltage will be retarded. The reflective signal travels back to the transmitter and adds to the incident signal at that point.

Thus, any mismatch at the antenna gives rise to a second 'travelling wave' which goes in the opposite direction from the incident wave. When $Z_1 = Z_0$ the reflection coefficient is zero and there is no reflected signal. In this case all power is accepted by the antenna and this is the ideal situation where VSWR is concerned. The problem is that this condition is rarely, if ever, achieved and so "p" will have a value different from zero. Note that "p" can have negative values, but in calculating VSWR from the reflection coefficient, only the "absolute value" is used - which is a positive value lying between 0 and 1.

As the two travelling waves pass each other in opposite directions, they set up an interference pattern called a "standing wave". At certain places on the feedline the voltages will add producing a voltage maximum, and at others their relative phase difference will cause a voltage minimum to exist on the feedline. These maximum and minimum points occur 1/4 wavelength apart. In the days when open-wire feedlines were used these points could easily be measured with simple indicators. Coax cable however presents another problem since the "inside" of the cable is not readily available for measurements. Consequently, VSWR measurements on coax are usually made at the transmitter end of the feedline. Therefore you are presented with the VSWR of the entire system which includes all losses associated with the entire system.

INTERPRETING WHAT YOU HAVE READ

Many VSWR meters are calibrated to read FORWARD power as well as REFLECTED power. They may actually be measuring voltage,

and simply have the scales calibrated in power. The important point is to understand what the meter is actually telling you. Assuming for the moment that the VSWR meter contributes no errors, the FORWARD reading is the SUM of the forward power and the reflected power. As a result, it is greater than your actual power output. The REFLECTED power reading is that amount of power which was not initially absorbed by the antenna and has been sent back down the feedline. At the transmitter end it encounters the transmitter output circuitry and is re-reflected back towards the antenna. This happens because you do, in fact, have a VSWR greater than 1:1 as seen by the transmitter. When the re-reflected power encounters the antenna, a portion of it is absorbed and the whole process starts over again.

Ultimately then, most of your signal is eventually absorbed by the antenna. You might be tempted to think that all of this bouncing back and forth would cause "smearing or blurring" of your signal but this is not so. The average transmitted signal appears as a "steady-state" signal to the feedline and antenna. Remember your signal is travelling at a significant fraction of the speed of light. For instance, the velocity of propagation of RG-8/A is 0.66 or 2/3 the speed of light. The speed of light is close to 1000 feet per microsecond, and a dot or voice peak takes milliseconds to complete. If the speed of light were 20 miles-per-hour then the situation would be completely different and we probably wouldn't have radio transmission at all. (Ed. Note, it would be as fast as the mail then.)

Given the reality then that almost all power launched down a feedline reaches and absorbed by the antenna, one has to wonder why VSWR is all that important. The importance is due to the fact that feedlines have losses and, antennas have something called radiation efficiency. They are what make proper interpretation of VSWR important. Power is lost due to feedline attenuation and this loss goes up as the VSWR goes up. The efficiency of an antenna is determined by the ratio of its "radiation resistance" to its "loss resistance". Antenna efficiency can simply be described by the following equation:

$$\% \text{ Efficiency} = [R_a / (R_a + R_{\text{loss}})] \times 100$$

The radiation resistance is R_a , and R_{loss} is made up of any associated losses of the antenna such as loading coils and ground systems. How well you "get out" therefore depends more on low losses and efficient antennas than on what your actual VSWR is as the following example will show.

THE EFFECTS OF ATTENUATION ON VSWR

Early in this discussion the statement was made that your VSWR may appear to be very low and yet there could be serious things wrong with your antenna system. Figure 1 shows how this can happen. The curves in the figure represent the forward and the reflected voltage on an antenna which has a feedline loss of 3 dB, and a reflection coefficient of $p=0.5$. In this example the actual value of voltage is inconsequential and can be considered to be "E". We are only interested in relative values of "E" in any case. The length of the feedline is also arbitrary since we are only concerned with its total loss between transmitter and antenna.

Figure 1

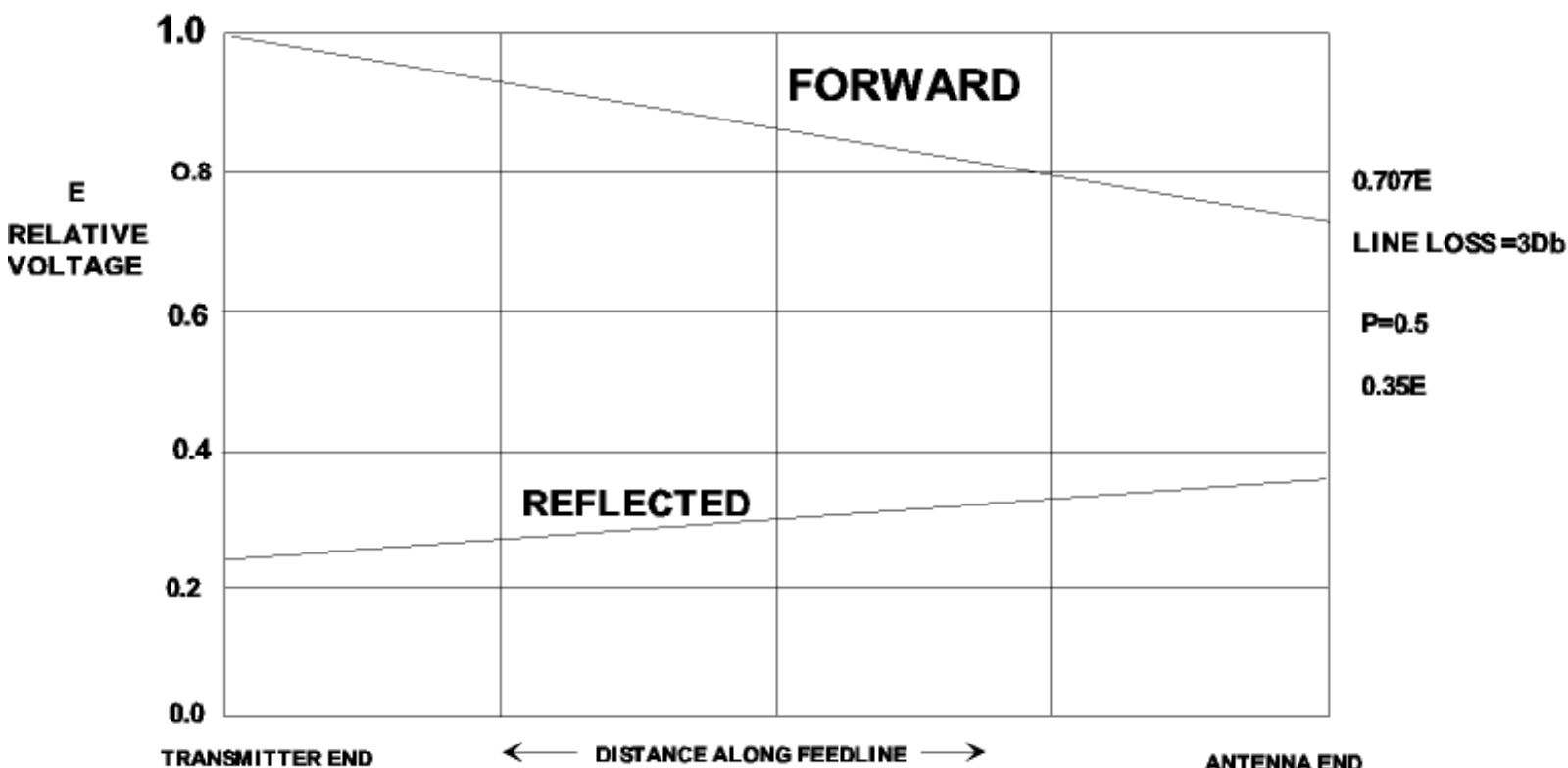

FIGURE 1: EFFECT OF LINE LOSS ON SIGNAL AMPLITUDE

The signal voltage "E" starts out at full value -1.0 E - on the feed line and is attenuated at a 3-dB rate. This means that the voltage will only be 71% - or 0.707E - when it reaches the antenna terminals. Remember that while 3-dB is a factor of two for power considerations, power is proportional to E-squared, consequently E will be only 0.71e when it arrives at the antenna input. The top curve in Figure 1 shows the FORWARD voltage decay as it travels down the feedline to the antenna input.

Since the antenna in this example has a reflection coefficient of 0.5, this means that 1/2 of the incident voltage will be reflected back down the feedline. This value is (0.5 X 0.71E) or 0.35E volts. The feedline has no way of knowing which way signals are traveling, so this reflected voltage will suffer the same 3-dB attenuation on the return trip. When it arrives back at the transmitter end of the feedline its value is only (0.71 X 0.35E) or 0.25 volts. The VSWR meter sees this value and since

$$\text{VSWR} = (E_{\text{fwd}} + E_{\text{ref}}) / (E_{\text{fwd}} - E_{\text{ref}})$$

the VSWR meter will read 1.67:1

That value of VSWR is guaranteed to make almost everyone happy, but your antenna system is not very good. The 3-dB loss down the feedline means only 1/2 of your output power reaches the antenna, and if your antenna has significant losses, something less than 1/2 of your power will be radiated depending upon how bad the losses really are. If for instance, the loss resistance equals your radiation resistance, the antenna is only 50% efficient meaning only 1/4 of your output power is actually radiated. Yet that reading of 1.67:1 looks fine. A reflection coefficient of $p = 0.5$ means your antenna is not well matched to the feedline. VSWR can be calculated from the reflection coefficient by the following:

$$\text{VSWR} = (1+p)/(1-p)$$

Using this formula shows your VSWR at the antenna is 3:1, quite a different value than your VSWR meter reads. The difference in the input and output VSWR values is due to the loss introduced by the feedline. Figure 2 shows how this loss can cause you to get a different VSWR depending upon where you measure VSWR in a feedline. You can measure VSWR at the antenna end of the feedline, but it is usually impractical to do.

Figure 2

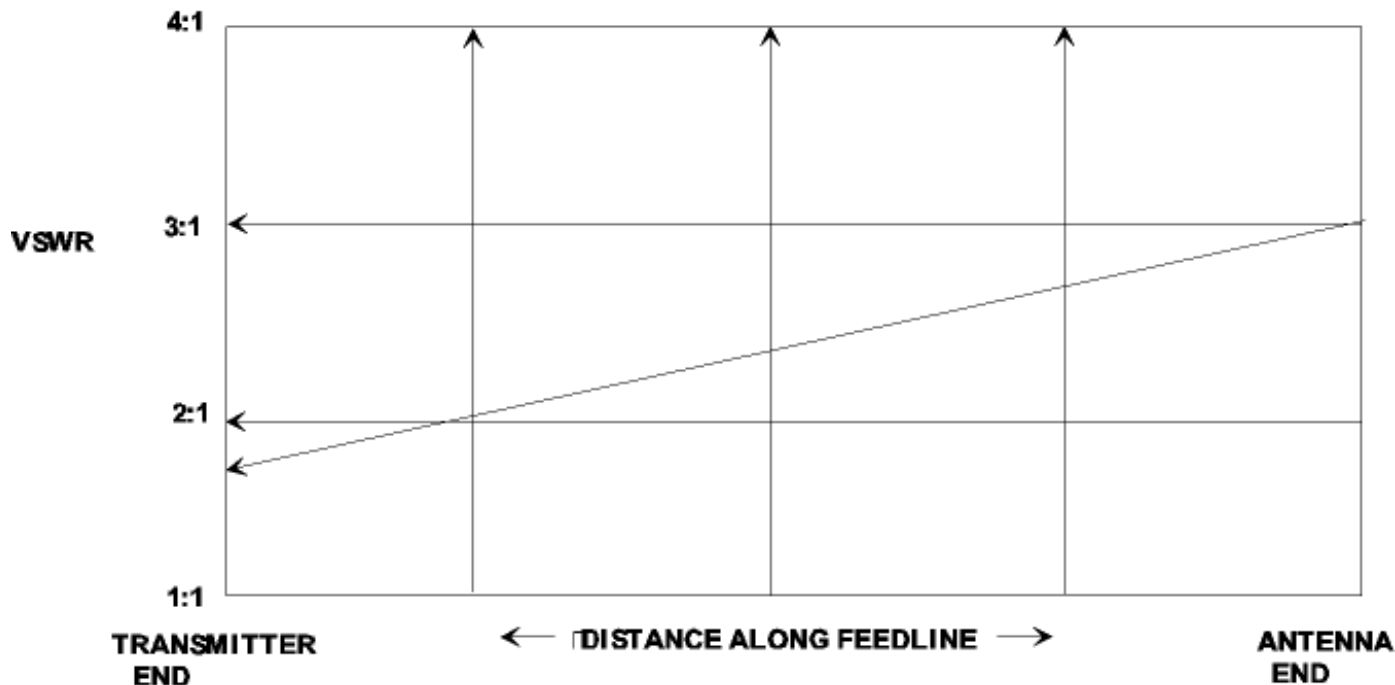

FIGURE 2 EFFECT OF LINE LOSS ON VSWR

You can use 1/2 wavelengths of coax between your VSWR meter and the antenna because a 1/2 wavelength of cable repeats the impedance it sees. The only problem is that you are introducing other possible elements into your measurements. But let's assume that your VSWR measurement at the feedline is reasonably close to what is actually occurring on the feed line, and that your feedline losses are not great. The burning question still is "how good or bad is the VSWR reading?"

VSWR AND TRANSMITTED POWER

Let's assume you have an efficient antenna, fed with a low-loss feedline so that the VSWR meter at the transmitter gives you a true reading of 1.65:1. There is no real reason to try to lower it, in fact the same would hold true if the reading were 2:1. Figure 3 is a chart showing the equivalence of VSWR to RETURN LOSS(dB), REFLECTED POWER(%) and TRANSMISSION LOSS(dB). Return loss is related to reflection coefficient by the equation:

$$\text{Return Loss} = -20\log_{10}(p)$$

It is just another way of measuring VSWR. For example, with a perfect 1:1 VSWR there would be no reflected power consequently the return loss on the feedline would appear to be infinite. A short or open circuit at the antenna is the worst case scenario since the reflection coefficient would be $p = 1.0$. All incident power would be reflected, and with a lossless feedline the return loss would be 0-dB. this is what the RETURN LOSS (dB) column refers to

The most informative columns in Figure 3 are the REFLECTED POWER(%) and the TRANSMISSION LOSS(dB) columns since they provide an answer to our question of whether further reduction of VSWR is worthwhile. Figure 3 shows that for a VSWR of 1.65:1 the reflected power is only 6.2% of the incident power, and the transmission loss is only 0.27 dB. In more familiar terms, if you count an S-unit as 6 dB, then the 0.27 dB loss is only 1/22 of an S-unit. A reduction of the VSWR to 1.5:1 would provide only a 0.09 dB reduction in transmission loss. This is not worth the effort it would take to achieve such a miniscule increase in power.

Figure 3

| VSWR | Return Loss (dB) | Reflected Power (%) | Transmiss. Loss (dB) | VSWR | Return Loss (dB) | Reflected Power (%) | Transmiss. Loss (dB) |
|------|------------------|---------------------|----------------------|------|------------------|---------------------|----------------------|
| 1.00 | ∞ | 0.000 | 0.000 | 1.38 | 15.9 | 2.55 | 0.112 |
| 1.01 | 46.1 | 0.005 | 0.0002 | 1.39 | 15.7 | 2.67 | 0.118 |
| 1.02 | 40.1 | 0.010 | 0.0005 | 1.40 | 15.55 | 2.78 | 0.122 |
| 1.03 | 36.6 | 0.022 | 0.0011 | 1.41 | 15.38 | 2.90 | 0.126 |
| 1.04 | 34.1 | 0.040 | 0.0018 | 1.42 | 15.2 | 3.03 | 0.132 |

| | | | | | | | |
|------|-------|-------|--------|------|-------|------|-------|
| 1.05 | 32.3 | 0.060 | 0.0028 | 1.43 | 15.03 | 3.14 | 0.137 |
| 1.06 | 30.7 | 0.082 | 0.0039 | 1.44 | 14.88 | 3.28 | 0.142 |
| 1.07 | 29.4 | 0.116 | 0.0051 | 1.45 | 14.7 | 3.38 | 0.147 |
| 1.08 | 28.3 | 0.144 | 0.0066 | 1.46 | 14.6 | 3.50 | 0.152 |
| 1.09 | 27.3 | 0.184 | 0.0083 | 1.47 | 14.45 | 3.62 | 0.157 |
| 1.10 | 26.4 | 0.228 | 0.0100 | 1.48 | 14.3 | 3.74 | 0.164 |
| 1.11 | 25.6 | 0.276 | 0.0118 | 1.49 | 14.16 | 3.87 | 0.172 |
| 1.12 | 24.9 | 0.324 | 0.0139 | 1.50 | 14.0 | 4.00 | 0.18 |
| 1.13 | 24.3 | 0.375 | 0.0160 | 1.55 | 13.3 | 4.8 | 0.21 |
| 1.14 | 23.7 | 0.426 | 0.0185 | 1.60 | 12.6 | 5.5 | 0.24 |
| 1.15 | 23.1 | 0.488 | 0.0205 | 1.65 | 12.2 | 6.2 | 0.27 |
| 1.16 | 22.6 | 0.550 | 0.0235 | 1.70 | 11.7 | 6.8 | 0.31 |
| 1.17 | 22.1 | 0.615 | 0.0260 | 1.75 | 11.3 | 7.4 | 0.34 |
| 1.18 | 21.6 | 0.682 | 0.0285 | 1.80 | 10.9 | 8.2 | 0.37 |
| 1.19 | 21.2 | 0.750 | 0.0318 | 1.85 | 10.5 | 8.9 | 0.40 |
| 1.20 | 20.8 | 0.816 | 0.0353 | 1.90 | 10.2 | 9.6 | 0.44 |
| 1.21 | 20.4 | 0.90 | 0.0391 | 1.95 | 9.8 | 10.2 | 0.47 |
| 1.22 | 20.1 | 0.98 | 0.0426 | 2.00 | 9.5 | 11.0 | 0.50 |
| 1.23 | 19.7 | 1.08 | 0.0455 | 2.10 | 9.0 | 12.4 | 0.57 |
| 1.24 | 19.4 | 1.15 | 0.049 | 2.20 | 8.6 | 13.8 | 0.65 |
| 1.25 | 19.1 | 1.23 | 0.053 | 2.30 | 8.2 | 15.3 | 0.73 |
| 1.26 | 18.8 | 1.34 | 0.056 | 2.40 | 7.7 | 16.6 | 0.80 |
| 1.27 | 18.5 | 1.43 | 0.060 | 2.50 | 7.3 | 18.0 | 0.88 |
| 1.28 | 18.2 | 1.52 | 0.064 | 2.60 | 7.0 | 19.5 | 0.95 |
| 1.29 | 17.9 | 1.62 | 0.068 | 2.70 | 6.7 | 20.8 | 1.03 |
| 1.30 | 17.68 | 1.71 | 0.073 | 2.80 | 6.5 | 22.3 | 1.10 |
| 1.31 | 17.4 | 1.81 | 0.078 | 2.90 | 6.2 | 23.7 | 1.17 |
| 1.32 | 17.2 | 1.91 | 0.083 | 3.00 | 6.0 | 24.9 | 1.25 |
| 1.33 | 17.0 | 2.02 | 0.087 | 3.50 | 5.1 | 31.0 | 1.61 |
| 1.34 | 16.8 | 2.13 | 0.092 | 4.00 | 4.4 | 36.0 | 1.93 |
| 1.35 | 16.53 | 2.23 | 0.096 | 4.50 | 3.9 | 40.6 | 2.27 |
| 1.36 | 16.3 | 2.33 | 0.101 | 5.00 | 3.5 | 44.4 | 2.56 |
| 1.37 | 16.1 | 2.44 | 0.106 | 6.00 | 2.9 | 50.8 | 3.08 |

Further examination of the chart shows that a VSWR of 2.6:1 results in only about 1 dB of transmission loss. A high VSWR of 6:1 shows just a 3 dB transmission loss, but this is 1/2 an S-unit. You will still be getting out but this is becoming a significant loss. Your feedline will be dissipating more power than it should, and there may be other serious things wrong with your antenna system.

Throughout this article you've noticed the use of the term "antenna system". The word "system" means you must pay attention to other things besides just the VSWR and your power output. Each component of your antenna system must be optimized to get the best results. Many factors must be considered such as operating frequencies, bandwidth requirements of the antenna system, heights, and directivity, all of which affect its efficiency. Since the height of your antenna, and your operating frequency determine both the length of the feedline and its losses the interfaces become very important. So there are a number of trade-offs which must be considered when you contemplate putting up a good antenna system, but these are tales for other times.

You can build or buy your own VSWR meter, but make sure that you understand what it is measuring and what it is really telling you. Then once you are satisfied that you have put up a really efficient antenna, fed with a low loss feedline, you can sleep well knowing that to try to reach the ultimate 1:1 VSWR is only an ego trip. As a rule of thumb, any accurate VSWR reading under 2:1 is probably not worth the effort to achieve if the other elements of your antenna system are the best you can make them. In fact you might be surprised to find that you really do have a low VSWR when you put up the best antenna and feedline you can. There is an old saying in ham radio that "a dime in the antenna is worth a dollar in the transmitter any day". Try it and see if you don't agree. **-30-**

Editors note:

W6VAT has a lot of good points, and careful attention should be paid to what is covered in his article, as it can make a difference in your signal. A case in point involves a ham club that I belonged to many years ago. They had just gotten the license for their repeater, and the only antenna that was available was a commercial antenna fed with ancient heliax. The antenna had only a small amount of reflected power and it seemed to get out well. Everyone was happy, and all was well with the world.

Until my boss who was a ham and I took the liberty of checking out the repeater with the equipment from the two-way shop. When I disconnected the RG-8A pigtail, water poured from the heliax for about 5 minutes. But the Bird showed no reflected power with a 10 watt element and 50 watts forward. This was met with extreme disbelief when the club members were told of the water cooled coax. No one wanted to spend the money to replace the antenna and coax. However, since we had a very heavy rain just before the meeting, duplication of the waterfall was easily achieved.

To the extreme displeasure of the older members who wanted to "patch the feedline and connections" a motion to spend the money to replace the old antenna and coax with new everything. After the purchase of a Ringo and some 1" heliax and the installation of same, the repeater range was tripled. The grumblers did not like the Ringo, as "it was not good enough". And, after I had left the area, they spent nearly two hundred dollars for a commercial antenna cut for the frequency, which they purchased from a club member who ran a two way shop and was adamant that the Ringo was no good. They were totally destroyed to find out that the high dollar antenna gave them no more range than the Ringo.

The moral to this story is things are not always as they seem, especially when it comes to VSWR, coax, and antennas that seem to work on frequencies that they shouldn't. Never take anything for granted, especially when it is your RF going up the flue. **-30- K5CNF.**

Send mail to webmaster@antennex.com with questions or comments.

Copyright © 1988-2004 All rights reserved - *antenneX*©

Last modified: July 04, 2004

ANTENNA TOPICS

[Antenna Software and more](#)

[GW0TQM's Mag Loop page](#)

[PA3HBB's site - Magnetic loops and more!](#)

[End feds, doublets etc - nice reading](#)

[End fed antenna ideas](#)

[Nice antenna designs for HF and VHF \(PA3HBB\)](#)

[A Short dipole for 80M](#)

[CT1ETT's keys, mag loop and rigs](#)

[Excellent site for antennas!](#)

[A Simple LED SWR Bridge](#)

[The Cobwebb HF Antenna](#)

[The Random Wire Vertical](#)

[Notes on the Random Wire Vertical](#)

[A Light Duty Mast](#)

[A Mini ATU](#)

[The OHR WM2 Wattmeter](#)

[The Broken Quad](#)

[Groundplanes by G3PTO](#)

[SM0VPO's Mini HF Vertical](#)

[N3GO's J-pole](#)

[A Multiband loop](#)

[How to make mobile/portable whips](#)

[A Resistive SWR Bridge for QRP Use](#)

[The Cross Field Antenna](#)

[The Lattin 5 Band Antenna](#)

[A practical 160m antenna](#)

[The Square Pole](#)

[Try an Inverted-L](#)

[The G5RV multiband HF Antenna](#)

[More on The G5RV multiband HF Antenna \(incl. 160m\)](#)

[The W3EDP HF antenna](#)

[The 'Shorty' mini-dipole for 14mHz](#)

[Another Antenna Idea \(A 3-band dipole\)](#)

[A Shortened 7mHz Dipole](#)

[Modified Z Match ATU](#)

[A Single Coil Z-Match ATU](#)

[An Antenna idea for the Smaller Garden](#)

[A Magnetic Loop](#)

[The Rockloop Compact HF Antenna](#)

[An Antenna for Portable Use](#)

[The Autek Antenna Analyzer](#)

[The MFJ259 Antenna Analyzer](#)

[Click To View SMOVPO's Pages For More Antenna Ideas](#)

W4RNL's WEB SITE - MINE OF INFORMATION ON ANTENNAS!

[Click for the web site](#)

Another great site for antennas!

[Click here](#)

Frank, G3YCC

[Back to the first page](#)



The CarChip™ ODB II Scan Tool
is @ www.provantage.com



Find on this site...

[Site Index](#)

- [Exams](#) Search site: Call sign search:
•[Clubs](#)
•[Hamfests](#)
•[Addresses](#)

ARRL Member Login...

Username: Password:

[Register](#)

Quick Links...

- [Join or Renew](#)
- [Catalog & Store](#)
- [ARRL Courses](#)
- [Classifieds](#)
- [Getting Started](#)

[Operating Activities](#) [Licensing](#) [News/Bulletins](#) [Services](#) [Educational](#) [Public Service](#) [Support](#) [Donate to ARRL](#) [ARRL Info](#) [Text-only/Printable](#)

Antenna Projects

[ARRL Technical Information Service page](#) · [TIS Menu page](#)

Introduction

QST, through the years, has had more articles on antennas than any other subject. This is probably because your antenna, although it can be the least expensive, easiest to construct component of your station, can have the greatest effect on performance.

The main feature here is a menu of antenna pages divided into type and use. There are all kinds of antenna projects you can build for home, portable and mobile use, HF and VHF. Go to the [Technical Information Antenna Projects Menu](#) to find what you need. For the new-comer there is a special [Beginners Section](#) covering both HF and VHF antennas.

Additional resources

- [The ARRL Antenna Book](#)
- [ARRL's Wire Antenna Classics](#)
- [More Wire Antenna Classics Volume 2](#)
- [Vertical Antenna Classics](#)
- [Antenna Compendium Vol's 1 through 6](#)
- [QST Magazine](#)

The [ARRL](#) has an extensive [catalog](#) of books and materials related to [Amateur Radio](#).

**ARRL Products:
Interference/DF**
[\(More\)](#)



**AC Power
Interference
Handbook** -- New

insights into the causes, effects, locating and correction of power-line and electrical interference. 2nd Edition.



**The ARRL RFI
Book** -- Practical
Cures for Radio
Frequency
Interference.



**Transmitter
Hunting** -- Radio
Direction Finding
Simplified



**The RSGB Guide
to EMC** -- Tackle
RF interference
problems and
understand the
underlying causes.

Technical Information Antenna Projects Menu

HF Antennas

VHF/UHF Antennas

[Beam/Yagi](#)

[Dipole](#)

[J-Pole](#)

[Loop](#)

[Mobile](#)

[Quad](#)

[Sloper](#)

[Trapped Antennas](#)

[Vertical](#)

[Other HF Antennas](#)

[Beam/Yagi](#)

[J-Pole](#)

[Mobile](#)

[Vertical](#)

[Quad](#)

[Other VHF Antennas](#)

[Information for HF and VHF beginners](#)

General Antenna Info Articles:

- [HF Amplifiers versus Antennas--One Ham's Opinion](#) (39,999 bytes, PDF file)
QST November 1998, pp. 54-56
The solution to "getting out better" is not necessarily "more power".
- [Low Power, Crummy Antenna](#) (293,108 bytes, PDF file)
QST December 1998, pp. 57-59
A major part of the fun of amateur radio is putting together a station that works from stuff you have just laying around. Antennas lend themselves to this practice nicely.
- [Antenna and Tower Safety](#) (15,694 bytes, PDF file)
QST June 2001, p. 91
- ["What's Up Top"](#)
QST June 1960, pp. 38-40
Crud and rust can be a real detriment to the performance of your antenna. Here are some procedures to make it look (and work) like new again.
- [Stacking Yagi Antennas](#)
By what distance should stacked Yagi's be separated?
- [Beam Talk for the Layman](#) (263,249 bytes, PDF file) **MEMBERS ONLY**
QST July 1958, pp.35-37
Step-by-step tuning of a gamma matched Yagi antenna and other thoughts on installation.
- [Sound-Card Antenna Measurements and Other Useful Techniques](#) (1,560,065 bytes, PDF file)
MEMBERS ONLY
QEX Jan/Feb 2002, pp. 33-46
Measure antenna and receiver performance and record results, even when you are not present, using your computer's sound card.
- [Tower and Antenna Wind Loading as a Function of Height](#) (192,267 bytes, PDF file)
QEX July/August 2001, pp. 23-33
- [A Low-Loss VHF/UHF Bias Tee](#) (279,405 bytes, PDF file) **MEMBERS ONLY**
QEX May/June 2002, pp. 52-54
A simple circuit that lets you superimpose DC control voltage onto the transmission line without altering the RF characteristics.
- [Tower and Antenna Wind Loading as a Function of Height](#) (192,267 bytes, PDF file)

QEX July/August 2001, pp. 23-33

- [An Inexpensive External GPS Antenna](#) (253,745 bytes, PDF file)

QST October 2002, pp. 36-39

An easy to build antenna for your GPS unit for better reception.

Web Links:

- [Stacking, Phasing and Matching Yagis](#)

This is a synopsis of a talk presented to the Sydney VHF DX Group on Tuesday March 16th 1999 by Gordon McDonald VK2ZAB

- [How to Become An Antenna Guru](#)

What Is An Antenna, Antenna Impedance, Transmission Lines, Radiation Pattern, Polarization, and more.

- [The Antenna Elmer](#)

Here you will find information about wire antennas as well as directional beams.

- [KBOYKI's Radio Zone](#)

On-line antenna designers, rooftop tower plans, gamma matches, and more

- [Amateur Radio](#)

My personal interest in amateur radio focuses on research into and education about antennas and antenna modeling.

- [EZNEC Antenna Software by W7EL](#)

EZNEC 3.0 and EZNEC pro 3.0 are full-featured 32-bit Windows applications

- [NEC4WIN95VM v3](#)

Antenna Simulation Software for Windows

- [Polar Plot by Bob Freeth \(G4HFQ\)](#)

A program that lets you see what the polar diagram of your relatable beam antenna actually looks like where it is operating.

- [AC6V's Homebrew Antenna Links](#)

- [Antennas, L. B. Cebik, W4RNL](#)

Theory (light) and practical information on all kinds of antennas.

- [Bill, NJ7P Coaxial Cable Searchable Database](#)

- [Lines of Magnetic Declination for North America 1990](#)

Useful to find true north for aligning your antenna

- [FM Broadcast Directional Antenna for 87-93MHz](#)

Build this ideal antenna for receiving distant Public Broadcasting stations

- [KF4VDF's Antennas](#)

Diagrams, measurements and calculators for designing and building all sorts of antennas

- [G4FGQ's Software](#)

New, original, high-quality, radio engineering/modeling programs. Not freeware -- just free gifts -- please help yourself -- no catch.

Article Reprints:

Note: Reprints are available from the Technical Department Secretary, ARRL, 225 Main Street, Newington, CT 06111. Article copies must be prepaid \$3 for ARRL Members, \$5 for non-members. You may order by telephone (860-594-0200) and pay by credit card. Reprints can only be sent by mail and cannot be sent by or attached to e-mail.

This information was prepared as a membership service by the American Radio Relay League, Inc., Technical Information Service, 225 Main St., Newington, CT 06111 (860) 594-0214. Email: tis@arrl.org (Internet). ARRL HQ is glad to provide this information on the Web free of charge as a service to League members and affiliated clubs.

If you have any questions concerning the reproduction or distribution of this material, please contact:

TIS Coordinator
American Radio Relay League
225 Main St., Newington, CT 06111
Tel: 860-594-0214 Fax: 860-594-0259
(email: tis@arrl.org)

Page last modified: 09:20 AM, 10 Dec 2003 ET

Page author: tis@arrl.org

Copyright © 2003, American Radio Relay League, Inc. All Rights Reserved.



[Add a Site](#)

[Message Board](#)

[Contact](#)

[Home](#)

[The Fan Dipole](#)

[Feed line characteristics](#)

[Feed Line Loss VS Frequency](#)

[Full Wave Loop](#)

[vhf ground plane plans](#)

[2 meter quagi plans](#)

[The half square](#)

[Host Your Ham Site With Us](#)

[You can have](#)

[\(email\) anything@yourcall.com](#)

[\(site\) www.yourcall.com](#)

ANTENNAS

FEATURED SITES

[Java Radio](#)

[Dx Spotting](#)

[Space Weather.com](#)

Below are links to some Antenna pages and sites. If you have an antenna page please send your link to us so we can share it with others. If you are looking for some info you can't find, let me know and I'll try and help you locate it. Be sure to check back as we are updating daily. If you have A link or info, send it for listing.

GENERAL INFO:

[Ham Radio History](#)

[Famous Hams](#)

[HF Band Plans](#)

SPECTRUM CATAGORIES

[Antennas](#)

[Clubs](#)

[Callsigns](#)

[Digital](#)

[DX](#)

[Exams](#)

[Hamfest](#)

[Homebrew](#)

[Humor](#)

[Manufacturers](#)

[Mods](#)

[Personal Pages](#)

[Publications](#)

[Repeaters](#)

[Scanners](#)

[Software](#)

[40 Meter 2 Element Parasitic Delta Loop](#)

A simple and inexpensive way to achieve substantial gain and reasonable F/B ratio.

[Amateur radio antennas](#)

Super Linear Loaded Inverted V ,Copper Cactus (Multi-Band J-Pole),The Stacked-J (Double High J-Pole), and more

[Antenna programs](#)

programs for all the common antennas, hf, vhf ,uhf and some experimental designs

[2 meter j-pole](#)

A simple J-pole antenna for 2 meters

[40 meter half square \\$29.95](#)

[All about baluns](#)

Theory and construction

[Srewdriver moble antenna mount](#)

A very nice mount from K9ROY

[DX dual dipole](#)

A wire yagi

[VHF/UHF Long Yagi Workshop](#)

Designs for VHF/UHF yagis

[Quickie Vertical](#)

[7 ELEMENT LOGCELL YAGI](#)

Claimed to be better than a regular yagi but on a shorter boom

[Fractal quad for 10 meters](#)

It's small, high performance, and unencumbered by electronic parts, transformers, discrete loads, and so on. And a 50 ohm feed

[Rotatable Dipoles](#)

6 meters, 20 meters and multiband

[NB6ZEP antenna](#)

A modified 20 meter Extended Double Zep, 40 thru 10 meters (with tuner)

[Cubicle quad antenna calculator](#)

This page makes calculates all dimentions for quad antennas, just enter the frequency. With detailed plans.



eHobbies has remote control plans, cars, rockets, helicopters and much more.

[1270Mhz Yagi Antenna](#)

Build your own antenna for the 23cm band (1250Mhz - 1280Mc) using some aluminium and this simple design

[2 EL. Quad for 10-12-15 meters](#)

Simple disign using bamboo poles, of course fiberglass, pvc, etc could be used.

[80 METER FRAME ANTENNA](#)

A nice antenna for limited space

[ANTENNA ROUND UP](#)

ANTENNA'S FOR 6, 10 AND 2 METERS

[K1TTT Technical Reference](#)

Links to antenna resourses

[Grounding is key to good reception](#)

Discussion on grounding.

[An Attic Coaxial-Cable Trap Dipole for 10, 15, 20, 30, 40, and 80 Meters](#)

A good antenna for HF operation on 6 amateur bands at a QTH with restrictive covenants that prohibit outside antennas.

[Clif's Ham Radio Page](#)

Summary of experience with restricted space antennas.

[No tuner required](#)

W6RCA's No-Tuner, All-HF-Band, Horizontal, Center-Fed Antenna

[Folded Dipoles](#)

Dimintions for the folded dipole antenna

[160/80 meter recieving loops](#)

Construct this loop for a lower noise receiving antenna

[The Gallery of the EME Arrays](#)

Huge picture gallery

[2 METER HALO ANTENNA](#)

A small horizontal loop

[Six Meter Antennas](#)

A 3 ELEMENT YAGI and A 6 meter halo

[Antanna calculators](#)

Some great antenna stuff here

[Antennex](#)

An antenna magazine

[Coax cable table](#)

Loss,velocity facter, etc

[The Gain of an Endfire Array](#)

This article looks at the maximum theoretically possible directive gain that could be obtained with an endfire array of given length or number of elements.

[Ground-mounted Verticals](#)

Designed verticals for you to build

[KB1GW's collection of Beverage Antenna Information](#)

[Rhombic Antenna Home Page](#)

Expanations and photos.

[A Simple Seven Element Yagi Antenna](#)

Quickly calculate the dimensions for a seven element Yagi-Uda Antenna. Simply enter the frequency in Megahertz and the script will do the rest.

[THE ST. LOUIS VERTICAL](#)

The St. Louis Vertical (SLV) offers portable enthusiasts an easy-to-build, easy-to-use antenna.

[Standard G5RV Information](#)

A discussion of the G5RV

[The Super J-Pole Antenna\(Collinear Design\)](#)

Javascript for calculating the lengths of tubing to be used for the construction of a Super J-Pole.

[Transmission Lines and Matching Systems](#)

Explanation

[Rhombic Antenna Home Page](#)

Very nice explanation with pictures

[Amateur Radio RF Safety Calculator](#)

Enter your gain, distance, etc and this page will let you know if you comply with FCC regulations

[Quibcal Quad](#)

Plans and pictures to build your own

[A Small Yagi for 50 MHz](#)

[Understanding electromagnetic fields and antenna radiation takes \(almost\) no math](#)

[Build a portable 10 meter yagi](#)

[Phased beverage arrays on 160M, 80M and 40M](#)

[Coaxial Traps](#)

[RF calculators](#)

[EME gallery](#)

pictures of eme antennas

[haarp](#)

HIGH FREQUENCY ACTIVE AURORAL RESEARCH PROGRAM H.A.A.R.P.

[RF GROUND SYSTEMS](#)

Everything you always wanted to know about rf grounding

[national lightning safty institute](#)

[Stacking Yagi Antennas](#)

[Using and Understanding Decibels](#)

[2 meter yagi](#)

[wire antennas](#)

[antenna](#)

W6RCA's No-Tuner, All-HF-Band, Horizontal, Center-Fed Antenna

[Projects and Info Center](#)

[Antennas & Transmission Lines](#)

[Smart Antenna Systems Tutorial](#)

A smart antenna system combines multiple antenna elements with a signal-processing capability to optimize its radiation and/or reception pattern automatically in response to the signal environment.

[THE \\$4 SPECIAL](#)

Sure, you can find "all-band wire antennas" for sale in the back pages of Ham magazines costing \$100 or more. But beware: Marconi spins in his grave everytime a ham buys an aerial instead of building it!

[The Stacked J-Pole](#)

[The Optimized Wide Band Antenna](#)

Notes regarding stacked installations of antennas

[Coaxial Collinear hints from K7ITM](#)

[How to Become An Antenna Guru](#)

Using these simple relationships, you can do antenna calculations with a wave of the hand and sound like a pro

[Bazookas and more](#)

[Crossed-Field Antenna References](#)

[The antenna elmer](#)

[How to build a 432 Mhz Quagi](#)

[AM Antennas](#)

If you are not satisfied with your AM reception, you are probably wondering "is there anything I can do to improve it?" Well, you have come to the right place!

ADDITIONAL RESOURCES

[hf Frequency allocations for swl](#)

[Wordwide grid squares/zones](#)

[HF Nets](#)

[Country List](#)

[ARRL, The premier site for hams worldwide](#)

[The F.C.C.](#)

[Add Link](#)

[Message Board](#)

[Contact](#)

[Home](#)

Web Hosting: \$12.95/month

KU4AY Web Hosting offers full featured Web Hosting accounts starting at \$12.95 with no setup fees and unparalleled OC3 connectivity. Imagine your own ham radio web site with "www.yourowncall.com as your web site and anythingyouwant@yourowncall.com as your email address. KU4AY Web Hosting Solutions





L. B. Cebik, W4RNL

1434 High Mesa Drive
Knoxville, TN 37938-4443



cebik@cebik.com

Amateur Radio

Amateur Radio is a communications service consisting of operators licensed and regulated in the United States by the Federal Communications Commission. Amateur radio operators, by regulation engage in emergency and other public service communications, maintain technical skills, and foster international good will via communications.

My personal interest in amateur radio focuses on research into and education about antennas and antenna modeling. The listings on this page link to some past and present research (and to some past research updated before posting on these pages). Since these are essentially working notebooks and not polished articles (for the most part), they may contain typos, misspellings, and a few grammatical infelicities. Moreover, they are subject to revision and updating whenever I discover something more accurate, more useful, or more interesting.



Tales and Technicals: A Little History and a Lot of Antennas

From time-to-time, I shall post some yarns, mostly taken from my collection of old books, manuals, magazines, and handbooks. I shall also occasionally post from the pages of my notebooks some technical information that may be of use to fellow and prospective hams. To keep this index from being too long to use, I have placed many items in collected groups. So be sure to check the listings that appear collect items together from time to time for additions. Since these are notes and some reprints of casual articles, there will be considerable overlap in places--and many large gaps in other areas. Nevertheless, let's begin with these items:

A Little History, a Little Humor, and a Little Seriousness

- [The Wouff-Hong and The Rettysnitch: Lost Traditions?](#)(02-16-1998)

- [The Wouff-Hong, the Rettysnitch, and the What? The Uggerumph](#) (04-27-2000)
- [10-10 and Lindbergh](#) (02-10-1998)
- [Q-signals in 1930](#) (02-10-1998, 01-08-2001)
- [The RST Standard of Reporting](#) (10-02-1997, 12-10-2001, 04-19-2004)
- [A Time to Reminisce](#) (02-21-1998)
- [To the Sea Again](#) (08-21-2000)
- [Why Call "CQ"?](#) (06-20-1998)
- [Everything Old Is New Again](#) (10-28-1998)
- [A Ten-Minute Timer That Just Won't Quit](#) (01-29-2000)
- [Understanding and Producing Scientific and Technical Articles, Proposals, and Reports](#) (07-28-1999)
- [On Socio-Cybernetic Modeling](#) (08-20-1999)
- [PVC Gurneys for All Occasions](#) (12-09-2002)
- [Thoughts on Caring for a Terminally Ill Loved One](#) (11-04-2002)
- [In Memory of Jean](#) (12-08-2002)

Antenna Modeling Software Notes

- [Antenna Modeling Programs](#) (01-23-2003)
- [Notes on Modeling Antenna Elements](#) (05-10-1998)
- [Notes on Modeling and Convergence Testing](#) (06-23-1997)
- [Modeling Loads and Transmission Lines Parts 1-4](#) (12-29-1997)
- [Modeling Trap Antennas](#) (04-02-1997)
- [Preliminary Notes on Trap Placement](#) (07-11-1997)
- [Systematic Trap Modeling](#) (07-12-1997)
- [Why I Use dBi Mostly](#) (06-23-1997)
- [Some Pitfalls of Careless dBd-ing](#) (06-03-1999)
- [Getting the Most Out of Antenna Patterns](#) (07-17-1997)
- [Reading a NEC Deck](#) (03-30-1997)
- [NEC-4 vs. NEC-2 With Stepped-Diameter Correction and Autosegmentation](#) (04-06-1997)
- [Notes on Two Limitations of NEC-4](#) (04-10-1997)
- [Multi-Diameter Dipoles: MININEC vs. NEC-4](#) (09-19-1997)
- [Close-Spaced Wires: MININEC vs. NEC-4](#) (09-24-1997)
- [Notes on Boom Effects with Short 3-Element 146-MHz Yagis](#) (10-22-2003)
- [Notes on Fat-Wire Dipole Convergence](#) (03-11-1998)
- [1 MHz Ground-Wave Analysis: A Comparison Among MININEC and NEC Modeling Implementations](#) (02-23-2001)

- [The Tee-Match: NEC Illusions and MININEC Realities](#) (01-07-1998)
- [Three-Element Yagi Models: Standards of Comparison](#) (06-21-1997)
- [NEC-2 and NEC-4: Reading Trends with Caution](#) (09-12-1998)
- [Modeling and Understanding Small Beams](#) (07-25-1999)

Practical Antenna Notes: Lower HF (Mainly) Vertical Antennas

- [Self-Contained Vertically Polarized Wire Antennas: A Family Album Parts 1-6](#) (05-15-1999, 01-14-2003)
- [Voltage Feeding SCV Loops](#) (08-14-1998)
- [The 40-Meter Bobtail Curtain as An All-Band Wire Antenna](#) (05-27-2003)
- [Notes on All-Band Use of Vertical-Plane Deltas](#) (10-13-1997)
- [Verticals Without Vertigo](#) (05-13-1999)
- [Some Techniques for Building a QRP Field Vertical](#) (05-24-2002)
- [The 5/8-Wavelength Mystique](#) (04-17-2001)
- [Some Facts of Life About Modeling 160-Meter Vertical Arrays Parts 1-5](#) (08-01-2001)
- [Models with Buried Radials: A Small Compendium](#) (08-31-2004)
- [Pursuing the \(Nearly\) Perfect Parasitic Vertical Array for 160 Meters Parts 1-2](#) (01-01-2002)
- [Half-Length 80-Meter Vertical Monopoles: the Best Method of Loading Parts 1-5](#) (05-12-1997)
- [Vertical Dipoles and Ground Planes: What Antenna Modeling Reports](#) (09-22-1998)
- [A Modeling Perspective on "Ground" Planes Parts 1-5](#) (06-06-1997)
- [The Insulated Radial Question](#) (05-01-2003)
- [Where Do I Hang My Hat?](#) (10-31-1998)
- [The 40-Meter 3-Way Special](#) (07-20-1997)
- [3 Wires = The Whole World](#) (02-05-1999)
- [A Triangle for the Short Vertical Operator](#) (02-05-1999)
- [An 80-Meter LPMA: A Design Idea and a Modeling Dilemma Parts 1-2](#) (05-01-2002) (PDF)

Practical Antenna Notes: Lower HF (Mainly) Horizontal Antennas

- [Just Tall. That's All. Some Principles of Portable Antennas to Strive For](#) (08-29-2003)
- [Wi're We Using Wire?](#) (01-19-1998)
- [A Note on Wire Size and Material](#) (08-08-1998)
- [The Zig-Zag Dipole-Doublet](#) (01-01-2000)

- [Unfolding the Story of the Folded Dipole](#) (03-12-2000, updated 12-04-2001)
- [Modeling the T2FD](#) (06-07-1999)
- [Notes on the Terminated Wide-Band "Folded Dipole"](#) (06-01-2000, 07-19-2000, 02-13-2004)
- [The G5RV Antenna System Re-Visited Parts 1-3](#) (05-21-2003)
- [The "Ideal" Back-Up Antenna for 80-20 Meters](#) (04-14-2000)
- [Some ABCs of A-B-C: Notes on Triangles of Doublets](#) (02-15-2003)
- [Resurrecting the Y-Doublet](#) (05-16-2003)
- [Notes on All-Band Use of Horizontal-Plane Loops](#) (10-28-1997)
- [A 40-Meter Star](#) (04-13-2003)
- [Horizontally Oriented, Horizontally Polarized Large Wire Loop Antennas](#) (03-29-1999)
- [Vertically Oriented Multi-Band Antennas](#) (05-20-2000)
- [The All-Band Center-Fed Inverted-L](#) (03-06-1999, 06-14-1999)
- [To Trap or Not to Trap](#) (12-20-1997)
- [Some Notes on NVIS Cloud Burners](#) (11-05-2002)
- [NVIS: From the Backyard to Professional Installations](#) (05-08-2003; 05-24-2003)
- [Vertically Radiating Horizontal Antennas](#) (03-15-1997)
- [The IL-ZX Antenna for 40 Meters](#) (06-30-1997, 12-27-2001, 09-27-2003)
- [Notes on Full and Shrunken 40-Meter Quads](#) (12-30-1997)
- [Some Notes on Lower-HF Wire Beams](#) (09-07-1997)
- [Notes on a Wire Beam for 80 and 75 Meters](#) (04-09-1997)
- [A Note on Substituting Wire Elements in Lower HF Arrays](#) (03-10-2000)
- [80-Meter Wire LPDAs](#) (04-01-2002)
- [Some Notes on Antenna Bandwidth](#) (01-22-1997)
- [40 + 30 = 50 \(Not 70\)](#) (10-23-2001)
- [Short Beams and Operating Bandwidth](#) (10-05-1997)
- [Don't Be Phased By Phasing](#) (02-04-1998)
- [My Top 5 Backyard Multi-Band Antennas](#) (08-11-2004)(PDF)

Practical Antenna Notes: Upper HF (Mainly): Yagis and Relatives

- [Horizontal and Vertical Yagi Orientation](#) (10-13-1998)
- [Lobe Formation With Height Increases in Horizontal Antennas](#) (04-30-1999)
- [Modeling 6 Long-Boom Yagis](#) (07-20-1998)
- [What Can We Expect From a 2-Element Beam? Parts 1-5](#) (05-09-1997)
- [Mastering Some Mysteries of 2-Element Beams](#) Part 1 (05-19-2001)
- [Mastering Some Mysteries of 2-Element Beams](#) Part 2 (05-24-2002)

- [The Monoband Log-Cell Yagi Revisited Parts 1 to 4](#) (07-14-2000)
- [The G4ZU Bird Yagi](#) (04-02-1997)
- [Coils, Linear Loads, and Capacity Hats: An Overview of Small Loaded Yagis](#) (01-17-1998)
- [Director/Driven Element 2-Element Yagis: Some Ideas for 12 and 17 Meters](#) (07-25-1999)
- **Using Moxon Rectangles for WARC-Band Antennas**
[Part 1: Some 17-12 Meter Ideas](#) (05-01-2000, 08-04-2000)
[Part 2: Some 30-17-12 Meter Ideas](#) (06-01-2000)
- [A Truly Portable Moxon Rectangle for Nearly No-Tool Field Assembly](#) (02-01-2003)
- [Designing Moxon Rectangles by Equation and by Model](#) (10-01-2000)
- [Moxon Rectangles \(with Dimension Calculator\): 16 Items](#) (12-04-2003)
- [The Elusive Moxon Nest](#) (06-01-2003)
- [Moxon-Modifying the C3-Type Tri-bander](#) (06-01-2002)
- [A Tale of 4 Beams: The X, the Hex, the Square, and the Rect](#) (09-01-2000)
- [Understanding the N0KHQ Coax Square](#) (12-08-2003)
- [Yagi Element Diameter Differences Do Make a Difference](#) (07-01-2000)
- [Notes on Reversible Yagi Arrays](#) (09-01-2003)
- [I Want to Build a 3-Element Yagi Parts 1-4](#) (08-01-1999)
- [Stacking Yagis](#) 3 Items (09-17-1999)
- [1-2-3: 1 Boom, 2 Bands, 3 Elements Each](#) (03-07-1998)
- [Three Forward-Stagger 5-Band Yagis from ON4ANT](#) (08-28-1998, 04-18-1999, 07-16-1999)

Practical Antenna Notes: Upper HF (Mainly): Other HF Arrays and Questions

- [Some Model Quads](#) 10 Items (04-02-1999, 08-05-2000)
- [New Quad Studies](#) 10 Items (2000-2002)
- [A Trap Small Quad for 12 and 17 Meters](#) (09-29-1997)
- [LPDA Design and Modeling Data](#) 6 items (10-22-1999)
- [Some Notes on LPDA Stubs](#) (08-10-2003)
- [A 3.5 Octave LPDA of High Potential Performance, But an Antenna that No One Will Build](#) (04-14-2000)
- [Long-Boom LPDAs for 14-30 MHz](#) (07-01-2001)
- [3 More 14-30 MHz LPDA Designs](#) (07-01-2001)
- [4-30 MHz LPDA Design Concepts](#) (03-01-2002)
- [A 10-Meter LPDA Parts 1-7](#) (11-21-1998)
- [Notes on HF General Coverage LPDAs Using 30-35' Booms](#) (09-01-2003)

- [Notes on a Long-Boom General Coverage LPDA](#) (11-01-2003)
- [The Birdcage Antenna](#) (03-18-1997)
- [The L-Antenna](#) (02-05-1999, 11-25-2002)
- [The B-Antenna](#) (02-05-1999)
- [17-15-12 and Simple](#) (05-11-1999)
- [A Vertical Doublet for 30-10 Meters](#) (12-01-1999)
- [Notes on Hatted Vertical Dipoles for 10 Meters](#) (01-14-2003)
- [EDZ Beam Update](#) (05-10-1997)
- [Feeding the EDZ](#) (08-27-1997)
- [The Expanded Lazy-H](#) (04-01-1999, 04-15-2003)
- [Curtains for the Extended Lazy-H](#) (04-15-2003)
- [An Almost Universal HF Back-Up Antenna For the Antenna Farm That Has Everything Else](#) (02-12-1999)
- [Suppose I Could Have Only One Wire Antenna. . .](#) (03-21-2003)
- [The Turnstile: An Omni-Directional Horizontally Polarized Antenna](#) (03-06-2000)
- [Some Notes on Two-Element Horizontal Phased Arrays Parts 1-4](#) (05-10-2002)
- [The HB9CV Phased Array and Gain Comparisons](#) (09-18-1999)
- [Horizontal Phased Arrays with Parasitic Directors](#) (08-27-1998)
- [Tinker Toys for Adults: Some Notes and Ideas on PVC for Antenna Applications](#) (08-29-2000)

Practical Antenna Notes: VHF/UHF (Mainly)

- [2 X 3 = 6](#) (07-25-1997)
- [Experimental Omni-Directional Antennas for 6-Meters](#) (12-27-2001)
- [The 64-\(Euro-\)Dollar Question](#) (01-01-2004)
- [Phased Yagis, EDZ Beams, and Landstorfer-Sacher Yagis](#) (07-28-1999, 09-16-1999, 04-10-2000, 02-14-2004)
- [The Half-Square on 2 Meters: Parts 1-3](#) (04-12-1999, 07-18-2002)
- [Some J-Poles That I Have Known: Parts 1-4](#) (01-08-2002)
- [Moxon Rectangles for 6 Meters](#) (02-03-2003)
- [The Moxon Rectangle on 2 Meters](#) (10-01-1999)
- [Building a 2-Meter Moxon](#) (11-01-1999, 12-18-1999)
- [Simplifying the Turnstile Moxon Rectangle Fixed-Position Satellite Antennas](#) (10-01-2001; 06-01-2003)
- [What's Wrong With This Turnstile Stack?](#) (05-15-2002)
- [Notes on the Batwing Parts 1-3](#) (03-01-2004)
- [In Pursuit of Better VHF Quad Beams: A Work in Progress](#) (04-21-2001)

- [Notes on Medium-Length 2-Meter Quads and Yagis](#) (01-24-2003)
- [Circling the Square Quad](#) (05-01-2004)
- [The Quad Beam as an Amateur Satellite Antenna](#) (07-01-2004)
- [A Collection of 220-MHz Yagi Designs : Parts 1-4](#) (03-29-2001)
- [Multiple Reflectors for Long-Boom Yagis](#) (10-06-2001)
- [Appreciating DL6WU Wide-Band Long-Boom Yagi Design: Some Preliminary Notes](#) (11-02-2001)
- [Long-Boom Yagi Sidelobe Suppression](#) (04-27-2002)
- [Preliminary Studies of Long-Boom Yagis for 420-450 MHz](#) (04-28-2003)
- [Scaling and Adjusting VHF/UHF Yagis](#) (12-01-2002, 07-09-2004)
- [An OWA Family of 2-Meter Yagis From 6 to 12 Elements : Parts 1-2](#) (08-02-2002)
- [Extending the 2-Meter OWA Family: Parts 1-3](#) (09-01-2004)
- [Notes on 6-Element Wide-Band 2-Meter Yagi](#) (12-26-2002)
- [The OWA Family Moves to 220](#) (09-02-2002)
- **Wide-Band Utility Yagis for 420-450 MHz**
 - [1. 4- and 6-Element Models](#) (08-01-2001)
 - [2. An 8-Element Model](#) (09-01-2001)
- [Some Basics of Very-Wide-Band Yagi Design : Parts 1-2](#) (10-01-2002)
- [The Flat-Plane Reflector for 432 MHz](#) (11-08-2001)
- [Modeling the Double-Diamond for UHF](#) (12-01-2001, 11-12-2002)
- [Corner Reflectors Revisited: Parts 1-3](#) (04-18-1999)
- [Corner Arrays for Personal Communications](#) (10-01-2001)
- [Planar and Corner Reflectors Revisited](#) (08-12-2004) (PDF)
- [Modeling the Dual Rhomboid: Parts 1-3](#) (08-16-1999)
- [High-Gain, Wide-Band Yagis for 10, 6, and 2 Meters](#) (09-01-1999)
- [Quagi and Yagi on 2 Meters: Some Preliminary Notes](#) (04-16-2001)
- [A 3-Moxon Polling Array for 914 MHz](#) (08-01-2000)
- [The Case of the Curly Collinear](#) (06-01-2004)
- [A 100-1000 MHz "Utility" LPDA](#) (12-01-2001)
- [CAP Emergency-Beacon Direction-Finding Antennas](#) (05-05-2003)
- [Some Notes on FM BC Antennas: Parts 1-5](#) (04-10-2003)
- [LPDAs for the 400-800-MHz Television Range: Parts 1 and 2](#) (03-20-2003)

Transmission Lines, Impedance Coupling, and Construction

- [12 Ways to See and Love Your Feeders](#) (05-19-1998)
- [Some \(Old\) Notes on Home-Brew Parallel Transmission Lines](#) (01-06-2000, 12-28-2001)

- [Values Along a Transmission Line](#) (11-25-1998)
- [When is a Quarter Wavelength Not a Quarter Wavelength?](#) (02-20-1998, 07-15-1999)
- [Some Aspects of Series and Parallel Coaxial Cable Assemblies](#) (12-26-2001)
- [Some Notes on Modeling Hybrid Transmission Line Stubs](#) (05-01-2002)
- [Series Matching: A Review](#) (02-05-1999)
- [Voltage, Current, and Impedance Along a Transmission Line](#) (04-01-1997)
- [Whose Afraid of a Little Matching?](#) (04-04-1998)
- [Notes on a Wide-Band 50/75-Ohm Coax Feed System for Low HF Band Dipoles and Vees](#) (11-29-1997)
- [Link-Coupled Antenna Tuners](#) (updated 05-20-1999, 12-30-2000, 03-01-2004)
- [Link-Coupled Antenna Tuners: A Tutorial: Parts 1 - 5](#) (11-25-1997)
- [Delta, ATUs, and Losses](#) (03-28-1998)
- [An LCL/LC ATU](#) (04-01-1996)
- [The Balanced-L Network](#) (12-13-2002)
- [Rotator Direction Controllers](#) (01-21-2001)
- [How Accurately Must We Aim a Beam?](#) (01-22-2001)

Continuing Series

- [An-Ten-Ten-nas](#): a series of articles for *10-10 News* on antenna basics having special relevance to 10-meter operation.
- [Antennas From the Ground Up](#): a series of articles on antenna basics for *Low Down*, the journal of the Colorado QRP Club. The emphasis will be largely on lower HF and wire techniques.
- [Antenna Modeling](#): a series of articles on antenna modeling specially prepared for *AntenneX*. The series aim is to help antenna modelers get the most benefit and least anguish from their programs.
- [Amateur Radio Continuing Education](#): a series of articles prepared over several years for the annual *Proceedings of the ARRL National Education Workshop*. The pieces range in scope from a full-scale proposal for a technical education series down to using a blackboard more effectively in the classroom. There are also links to some other educational sites.

HAMCALC: A Special Note. Numerous articles refer to HAMCALC, a suite of utility calculation programs developed for hams by George Murphy, VE3ERP. The information in the articles gives Murph's address for obtaining the current version on CDROM. Due to a bout of ill-health, HAMCALC is no longer available on CDROM. However, you can obtain [HAMCALC](#) from this link to the CQ Magazine site and download the current version of the suite in Zipped format. The site provides instructions for installation and use.

-- -- SEARCH -- --

Because the collection of material at the site has grown to fair proportions, I have added a search capability. Clicking on the "Search" button will lead you to a page containing a search engine. You need only enter in a key word (or words) of interest to get nearly instantaneous returns of links to articles containing the term (or terms). Not all articles will be of equal interest relative to your desired term, so use the search engine in conjunction with a scan of the article titles to isolate the items most likely to be useful to you.

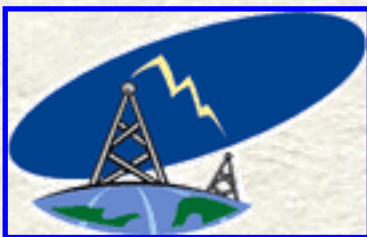

[Links to Other Antenna Information](#)

These links carry a lot of valuable information and ideas, ranging from antenna fundamentals to advanced topics in antenna design, modeling, feeding, and building. In addition, some provide links to other sites.



[Commercial Antenna Manufacturers and Vendors](#): A collection on known sources, offered because these pages often contain educational as well as commercial information.



[Other Amateur Radio Links](#): A small collection of links to organizations and linkage sites to help you find other good sources of information.

A Final Note

You will note an absence of reviews, analyses, and evaluations of commercially made antennas in the notes at this site. It would be inappropriate for me to remark on such antennas without having the antennas at hand and the appropriate range and equipment for testing them. These notes relate to antenna types and designs over which I have design control and are generally aimed to assist you to understand their operation. Even specific designs are not intended for uncritical replication, although a number of them have been successfully built and used. Still, the goal is not to produce a compendium of antennas for you to build. Rather, the object is to assist you to understand the antennas that you do build, use, or simply think about.

Please do not attempt to download the entire site using software designed for blind downloading. If you wish a record of the entire site, *antenneX* periodically produces a CDROM with the entire site on it. However, I have kept most (but, alas, not all) of the items at the site short enough to read at a single sitting. Pick something of interest, read, and digest. Then pick something else. Let your wandering interests be your guide. If you wish to read more on a subject, by all means, select a related item. Or, look in other good sources for information on the subject. This site is collection of items cast at an intermediate level. Hence, it is far from the last word on any subject, whether you think of basic theory underlying a matter or about very practical construction aspects of an antenna or system.

When you begin to track the items at this site, you become a companion down the path of antenna explorations that I have followed. Be certain that you are ever alert to pathways that are a function of your own interests. This pathway is not the only one, and it is far from the perfect one. But it has been and continues to be both a good and interesting one.

It has been my high pleasure to receive e-mail and regular mail that suggests these materials are of educational and technical service to a broad spectrum of individuals, both in the United States and around the world. Numerous items have appeared in the newsletters and other publications of amateur radio groups. The formal and informal distribution of some of the material, both as written and in translation, in areas where bound publications are unavailable or prohibitively expensive suggests that the energies used to develop and place some of the notes has been productive. So much to learn and so little time to learn it, but always time to share what I have learned along the way--lest it be lost.

Tales & Technicals: the CDROM

As a convenience to those who may pay for on-line time by the minute, have long-distance phone charges, or who have run out of paper downloading items, the site is now available on CD-ROM. The cut-off date for the recently updated Version 4.0 is December 1, 2003. The CD-ROM is available from [AntenneX](#) in the "Shopping Shack."

Other information will be made available on these pages as time goes by. For now,

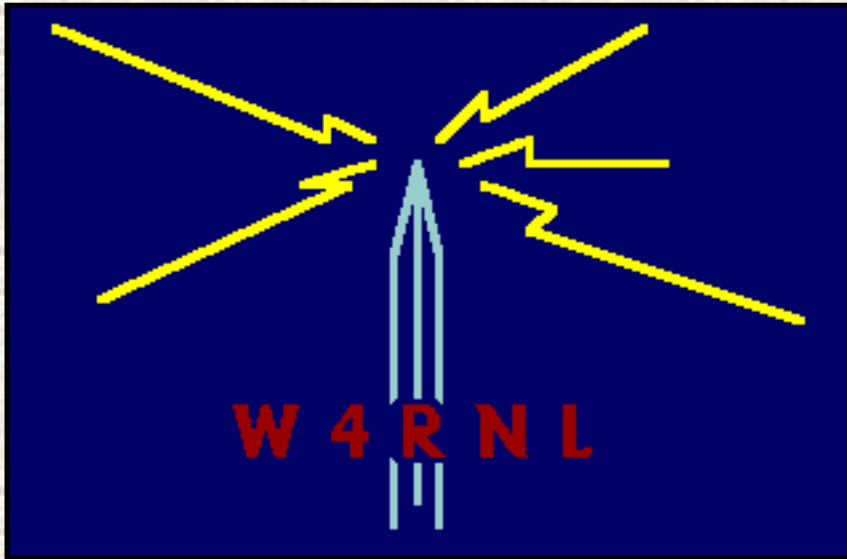

-73-

LB, W4RNL

Updated 09-01-2004



[Return to Home Page](#)

6 0 2 5 3 4



Pages by The House of Two Lions



APPLICATION NOTES-TABLE OF CONTENTS

Application Notes-Table of Contents

1. [Antenna and Feedline Measurements](#) 17 Aug 2001
2. [Return Loss Bridge Basics](#) 17 Aug 2001
3. [Duplexer Tuning using Bridge](#) 19 Jun 2004
4. High Performance VSWR Measurement INACTIVE
5. Protecting Sites from Intermods INACTIVE
6. [Replaceable Pin "N" Connector](#) 21 JUN 2004
7. [Reflected Power Measurements](#) 25 NOV 2000
8. Spectrum Analyzer Measurements INACTIVE
9. [TNF400 Instruction Sheet](#) 17 Mar 2003
10. [RLB150 Family: Calibration Procedure](#) 25 May 2004

website: eagle-1st.com
Phone: 928 204-2597
fax: 928 204-2568
22 Jun 2004 css-a



email: sales@eagle-1st.com
PO Box 4300
Sedona, AZ 86340

13 Sep 2002 II

Click on [Index](#) now.

Amateur Radio Station

G4FGQ's Software

Original, high-quality, radio engineering/modelling programs.

Not freeware -- just free gifts -- please help yourself -- no catch.

Download in a few seconds -- not zipped-up -- run immediately -- user friendly.

There *ARE* such things as free lunches after all.

Click on [Index](#) now.

#####

Occasionally programs may be amended. Minor changes such as correction of spelling errors, a more convenient arrangement in the display of results, a change in the number of decimal places, will not result in a change of program name. Only the date of issue will change as shown on a program's introductory screen when a program is run.

When significant changes, improvements or corrections are made in mathematical modelling the program name will be changed and the original program may no longer be available from this site. An announcement of a new name may be made on appropriate Internet newsgroups

and on the "Late-News" page of this website. When a serious error or bug is discovered in a program an explanatory note will appear in the "Program Bugs" page. See Index.

Click on [Index](#) now.

Site Index

Navigation: all active text is underlined. Click on the section of interest.

- | | |
|---|---|
| <ul style="list-style-type: none">• DOWNLOAD PROGRAMS FROM HERE• About this Site• Get Pascal source code from here• Program Size, Reliability and Accidents• What kind of programs are they?• What if?• Copying and Distribution of programs• My Portrait• Back to the Hoarding | <ul style="list-style-type: none">• Quotations• A Tale of Two Old Wives• What Does the SWR Meter Tell Us?• Reciprocity - an unpopular conception• A Bit About Reg, G4FGQ• Program Bugs• Feedback from You to Me• Site Statistics• LATE NEWS BOARD |
|---|---|

Click on "Index" to return here from anywhere on the site.

About this Site

There are few purely decorative features on these pages. No wallpaper, no pictures, decent or otherwise, no voices-off, and absolutely no adverts to distract the serious visitor. Consequently this text and the programs themselves will very quickly download themselves.

The site has been produced by Reg Edwards, UK Amateur Radio Station G4FGQ, for the benefit of the many Radio Amateurs world-wide who make friends and obtain satisfaction not only from operating a radio station but also from building and testing it. However, much construction consists of copying or adapting the work of others. But without a quantitative as well as a qualitative appreciation of radio basics the opportunities for innovative work are necessarily severely limited. Refer to Lord Kelvin's pertinent remarks and the great revolutionary work of the self-taught amateur Oliver Heaviside in the "Quotations" page.

Therefore, the primary purpose of this website is to freely distribute computer programs, composed by G4FGQ himself, which mathematically model the behaviour of components, circuits, power amplifiers, transmission lines, aerials, earth electrodes, radio propagation paths, etc. 'Working models' allow experimenters to examine quantitatively how the various input data interact and affect performance. They will relieve the hobbyist of some of the labour, the costs and the disappointments of constructing unsuccessful prototypes. Also of tedious arithmetic. He/she will gain further insight and will better appreciate the finer points of design. Opportunities for original contributions to this truly international hobby will be broadened.

[Index](#)

Download Pascal Source Code from here

For various (some dishonest) reasons I have been asked on numerous occasions to release the source code of programs available free from this website. To satisfy the genuine curiosity of those people who have asked for "the 'formula' for ", here are a few source code examples. Anyone who considers he understands the contents of these *.pas files is hereby granted permission to make full use of the information contained therein. If any future products result no reference shall be made to the author who is unable to provide any assistance in such matters.

Files are best read in non-proportionally-spaced text such as displayed by the mini word processor "NotePad".

To download a file click on underlined program name.

[GRNDWAV3.pas](#) * Groundwave propagation vs frequency, distance and terrain.

[TOPHAT2.pas](#) * Performance of top-capacitance loaded vertical.

[PADMATCH.pas](#) * T and Pi resistive-matching and minimum loss pads.

[Index](#)

Program Size, Reliability and Accidents

The number of possible ways in which a computer program can misbehave increases enormously with its size in bytes. A very large program is virtually certain to contain defects or bugs if only because of the impossibility of identifying and testing every one of these many ways. Debugging operations themselves are likely to introduce further defects. The importance of individual defects is uniformly distributed randomly between trivial and catastrophic.

A smaller program is a more reliable one. Unnecessary elaboration must be removed. Simplicity of source-code structure and understandability is the ultimate target. Small programs are better understood by both the programmer and during later maintenance. Testing will be more thorough and 'bugs' far less likely to remain. Consequently large programs must be composed of a number of small, independent, testable modules whose functions are precisely, unambiguously defined beforehand. Each module is then itself a complete small program.

The size of a complete program can greatly increase due to built-in precautions to protect itself, the computer and its user from the consequences of accidental entry of 'illegal' data. For example, illegal data might result in the maths processor being asked to calculate the square root of a negative quantity. To omit protection might result in the program 'crashing', sieze-up of the computer's operating system and the need to press the re-set button. The number of possible ways in which illegal data can be entered is also very large. To lay traps, deal safely with them all and inform the user, is impractical and will itself increase the liklihood of bugs

remaining in the finished product.

In G4FGQ's programs a bare minimum of protection is provided against entry of impossible data. Inevitably the user will make mistakes especially when unfamiliar with a new program. Mistakes are most likely to occur when entering numerical values. They fall into categories of incorrect measurement units, impossible physical proportions, ie, wire diameter greater than wire pitch, inclusion of non-numerical characters and using a comma for a decimal point. Obvious errors can be corrected, of course, by inspecting the data before pressing the Enter or (cr) key.

If you are running one of these programs in DOS where you have arrived from Windows, and it aborts, the system may not automatically switch you back into Windows. To return to Windows from DOS type EXIT (cr) against the DOS prompt. No harm is likely to come either to the computer or to the program as a result of being unceremoniously dumped back into the system.

To re-start a program which has just aborted while in DOS, from the same directory as the program is filed, just type the program's name against the DOS prompt followed by (cr). The .exe ending may be omitted. If you are not in the same directory then the name of the program must be preceded by the directory path to the program, the several items being separated by backslashes. Or you could change the current directory to that where the program is installed and then enter the program's name.

To Q(uit) or E(xit) from within a program do so by pressing the key indicated on the menu bar (Q or E) at the bottom of the screen. The option to quit is available only when the menu bar is visible. Pressing the quit key when the option is not available, if followed by the (cr) key, may indeed cause the program to close down but not in a very graceful manner.

[Index](#)

What kind of programs are they?

The source-code language of G4FGQ programs is Turbo Pascal. Unlike BASIC and various spreadsheet calculators, when compiled into a stand-alone program, as they all are, the Pascal source text is inaccessible and cannot be modified. Programs can be run only as the author intended. Integrity and authenticity are preserved.

Subject matters are technical and are necessarily dealt with quantitatively. At the heart of each program is a set of mathematical functions and procedures. Properties of the 'parts' used to construct the model are stored within the program. Other procedures accept from the experimenter the details specifying the model. The program then proceeds with its analysis and its conclusions are displayed. Advice or warnings may be given to the experimenter as appropriate.

Entry of numerical input data obliges the experimenter to clearly visualise the system modelled and approach it logically. He will learn to ask himself the right questions. The relative importance of the various factors affecting behaviour of the system will be better appreciated. This conforms with one of the purposes of amateur radio activities: self-teaching in the art of radio communication.

But before the amateur who takes pride in being purely practical and ignorant of theoretical matters now leaves, don't go, these programs have been written with you in mind.

To use these programs you need no more than the ability to estimate the number of rolls of wallpaper required to decorate your shack. That's not maths - it's only arithmetic. Authors of articles published in radio magazines often confuse these activities.

Programs are intended to relieve the user of the labour and tedium not only of mathematics but of arithmetic too. But the quantitative visualisation of a model cannot be avoided.

If you have not yet mastered the sizes of enamelled copper wire in terms of milli-metres and still work in 'thou of an inch', or 'mils' you will be at a slight disadvantage - all the programs are in metric units. But down-load a program anyway and let me know how you get on with it. You'll be back.

Actually, most of my programs are more than 10 years old. Most of the basic research had been done and the mathematical procedures had been developed by then. Recent work has been to extend their range of application, to combine related subjects into single programs, to generally tidy up loose ends, and to make programs presentable and user-friendly.

At present, several more are in their final testing stages, being cross-checked for mathematical inconsistencies, bugs, etc. More effort is spent on later quality-control than on producing the first useable version of a program.

It's good practice to put a supposedly finished program on the shelf for a month or so, allow one's mind to forget it, concentrate on something else such as producing this web site, even spending some time on the 'bands'. It is surprising how previously unnoticed defects then become obvious. However, these discoveries do not improve one's self-confidence - how many other hidden boobs remain?

Until recently I have never actually finished a computer program. The self discipline of saying "It's done. Date it. Archive it. Make it available on the Net" has not come easily.

[Index](#)

What if ?

All programs ask for a set of numerical values which describe or define the matter in hand. Often the data are physical dimensions plus a choice of operating conditions. This initial array of input data is always on view at the top of the screen.

When a set of results has been computed it is displayed in the lower part of the screen. It is now a simple matter to select and change any one of the initial values while asking "What if I set it to this particular value . . . ?" Immediately the question is answered. A similar question can then be asked about any other input parameter.

Later programs, on the press of a key, have the facility to sweep input parameters slowly in fine increments over wide ranges while immediately observing the effects on output data.

There is no need to go back to the beginning and re-enter a complete set of initial values although that particular option is available when needed. The response or behaviour of complicated systems when subjected to changes in inputs can be analysed and appreciated very quickly. Not only will programs be of practical use - by encouraging the user to become familiar with magnitudes and ranges of the essential factors they will also be of educational value.

[Index](#)

Copying and Re-distribution of Software Programs available from this Website

There are no restrictions on copying and re-distribution of self-produced software programs available free from this website, via any electronic, magnetic or optical means, by any individual or organisation, except that no copies shall be made, distributed or sold for commercial or financial gain.

With due regard to the foregoing I retain the Copy and Intellectual Property Rights for all programs. To preserve program integrity the source code of these programs is not normally available.

Signed:

R.J.EDWARDS

Radio Station G4FGQ & Website Proprietor

[Index](#)

**Amateur
Radio Station
G4FGQ**

Reg

**"You see, I'm not an
ogre. I'm really a kind
old chap."**

[Return to Index](#)



Send comments, queries, complaints, requests, suggestions, ideas to [Reg, G4FGQ](#)

NYLO'S NOTEPAD

Homebrew projects for radio & electronics enthusiasts

- ANTENNA PAGE -

[back to HOME page](#)

RAISING WIRE ANTENNAS

Wire antennas deliver the most bang for the buck, but they require a little work to put up. The most common way to put one up is to use the biological towers in your yard: the trees! To make this work, you need to install ropes to hold up the antennas. Here's a description of my favorite technique for getting those ropes up there:

[SETTING ROPES IN TREES FOR WIRE ANTENNAS](#)

ANTENNA PROJECT SELECTOR

VHF ANTENNAS

[2 meter HT Handipole](#)

Add some gain over your 'rubber dummy load' with this full size dipole on your HT.

[2 meter rollup J-pole](#)

Compact portable companion for travel or temporary operation. Hang it up anywhere.

[2 meter 4 element, portable yagi](#)

This yagi breaks right down and the elements store right inside the boom. The boom and mast can be used for walking sticks. Can be used as a base, as a portable or for foxhunting.

[2 meter, 4 element quad](#)

Rugged, yet lightweight powerhouse is great for base or portable and is especially *excellent* for foxhunting. It can also be constructed to break down for compact storage.

[2 meter Bicycle whip antenna](#)

This 1/2 wave, end-fed vertical with compact feed is built right onto a 1/4" fiberglass bicycle flag whip and *requires no ground plane nor radials!*. Excellent for bikes, boats, RV's, etc., or anywhere a compact vertical is desired.

MONOBAND HF ANTENNAS

[10 meter wire J-pole](#)

This end-fed half wave radiator is simple to make and even simpler to put up with a single rope. Can also be strung horizontally from your shack's window with a single rope to another support.

[10 meter wire collinear 'super' J-pole](#)

Yeah! More gain! Two 5/8 wave, phased radiators. Can be strung vertically for omnidirectional gain. This is a great omnidirectional gain antenna!

[20 meter wire J-pole](#)

This end-fed half wave radiator is simple to make and even simpler to put up with a single rope. Can also be strung horizontally from your shack's window with a single rope to another support.

40 meter wire J-pole

UNDER DEVELOPMENT

MULTIBAND HF ANTENNAS

[80-10 meter doublet with open wire feed](#)

Arguably the most popular 80-10 multiband antenna ever! Certainly, the most bang for the buck!. If you only build one, this should be it. Ultra simple to build and no pruning required. Good lobes of serious gain on the higher bands and low loss. Requires an outboard tuner with open wire terminals for best performance or you can use your rig's built-in tuner and a remote balun to match most bands. This antenna has the most gain when strung as a horizontal, flat-top, but it is versatile and can be strung as a sloper, or inverted vee.

[80-10 meter mobile vertical](#)

My latest project, and the results of 9 months of experimenting after putting an HF rig in my car. The signal reports have been excellent! This is, essentially, a homebrew version of a Texas Bugcatcher, except that the capacity hat is up at the top of the whip where it belongs for maximum efficiency. And, it's a lot cheaper!

Good luck and have fun with your antenna project!

--...MARK_N1LO...--

These antenna plan files are in Adobe Acrobat Portable Document Format (*.PDF files), the emerging standard for downloadable documents of all types on the web. To read or print the item, just click on it to download the file, then open it using the free Adobe Acrobat reader program, which you must have installed on your computer. Typically, Acrobat will open automatically and display your goodie. Follow the link below to get Acrobat if you don't already have it.

Here's where you can



Have you found something useful here? Got a comment? Drop me a line: n1lo (remove 'nospam' from address when sending)

You are visitor number  **since 12/21/99**



[HAMUNIVERSE.COM](http://www.hamuniverse.com)

Your Source for Ham Radio Fun and Information!



THE N4UJW ANTENNA DESIGN LAB

THE BEST HAM RADIO OPERATORS HAVE GOOD ANTENNAS!

YOU CAN'T WORK THEM IF YOU CAN'T HEAR THEM!

DESIGN OR BUILD YOUR ANTENNA HERE!

Antenna project contributions from all over the world!

HF, VHF, UHF AND LOTS MORE!

**All projects have been offered by their authors
to share will all hams worldwide!**

**A note of caution, we've re-calibrated our Humor Filter.
It still has a few bugs, but is working better now but use caution!
Please feel free to take a look around now at these most popular
antenna projects and information and come back later
when the antenna farm is in full bloom!**

**Some of your clicks below will take you away from our site,
so click your back button to return here.**

[THE 2 METER SSB SQUARE LOOP](#)

[NEW 6 METER ROTATABLE DELTA LOOP](#)

[HOW TO USE AN ANTENNA TUNER](#)

[2 METER HENTENNA](#)

[BUILD AN ALL BAND "UGLY" BALUN](#)

[TWO CLASSICS THE DIPOLE AND THE INVERTED V](#)

[6 METER ZIP CORD EDZ 50 OHM FEED](#)

[BUILD AN ALL BAND STURBA CURTAIN!](#)

[ANTENNA PROGRAMS DE VE3SQB YOU MUST SEE!](#)

[BASIC YAGI DESIGN FOR HOMEBREW](#)

[2 METER SSB YAGI ANTENNA PROJECT](#)

[MULTIBAND HF DIPOLE PROJECT](#)

[2 METER SLINGSHOT RE-VISITED](#)

[6 METER HALO LOOP](#)

[6 METER EDZ SIGNAL SQUIRTER](#)

[3 ELEMENT BEAM FOR 6](#)

[ANOTHER 6 METER LOOP](#)

[THE ONE ELEMENT BEAM! \(Also see next listing\)](#)

[ONE ELEMENT BEAM 20 THRU 6! Fantastic!](#)

[THE CLOUD WARMER NVIS BEAM](#)

[THE HENTENNA RE-VISITED](#)

[DESIGN A J POLE FOR ANY BAND](#)

[40 METER HUSTLER MOBILE ANTENNA MATCH PROJECT](#)

[EASY 2 METER GROUND PLANE +](#)

[DOUBLE BAZOOKA! SET YOUR SIGHTS ON BETTER QSO'S](#)

[THE FOUR DOLLAR SPECIAL \(save those bucks\)](#)

[THE LATTIN 5 BANDER](#)

[QY4 QUICK YAGI DESIGN PROGRAM DOWNLOAD](#)
[ARRL TECHNICAL INFORMATION SERVICE](#)
[ANTENNA DESIGN DOWNLOADS FROM QRZ](#)
[KB0YKI ANTENNA DESIGN](#)
[DECIMAL CONVERSION CHART FOR ANTENNA BUILDING](#)
[THE WA7CS TOWER PLANTING PROJECT](#)
[160 THRU 2 METER ANTENNA MARVEL! YA GOTTA SEE THIS!](#)
[BUILD A 2 METER 5/4 WAVE ANTENNA](#)
[ANOTHER GREAT J POLE DESIGN FOR 6 METERS](#)
[TRY OUT THAT NEW 40 METER ANTENNA HERE](#)
[VISIT THE CUSHCRAFT ANTENNA TECHNICAL LIBRARY](#)
[THE "LL COOL J" - 2 METERS FOR A SONG](#)
[20 METER "HAMSTICK YAGI"](#)
[20 METER 2 ELEMENT HAMSTICK VEE](#)
[GET A GOOD GROUND! Read the article!](#)
[NEW COAX-FED SLOPER LONG WIRE BY LA1IC](#)
[NEW SLOPING INVERTED V BY LA1IC](#)
[NEW 3 HALF WAVELENGTH VEE](#)
[NEW INVERTED VEE LONG WIRE](#)
[MORE ANTENNA SITES TO VISIT](#)
[K5AT ANTENNA LINKS](#)
[ANTENNAS "THE EASY WAY" DISPELL THOSE MYTHS!](#)
[ANTENNA THEORY AND TRAINING](#)
[PRESENT BY THE UNITED STATES NAVY](#)
(Some files below are under construction)
[WAVE PROPAGATION](#)

Do you have a great antenna project or antenna building experience you would like to share with your ham friends worldwide and would like it published on HAMUNIVERSE.COM?

It's easy! [Click here for details](#)

LOTS MORE **GROWING** IN PROGRESS!

CLICK [HERE](#) TO GO BACK TO [HAM UNIVERSE INDEX](#)

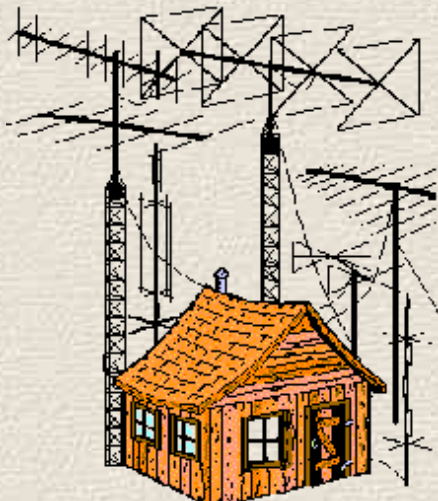

USE THE BARNS AND NOBLE LINK BELOW TO FIND THAT ANTENNA DESIGN BOOK YOU'VE BEEN WANTING! FANTASTIC SELECTION.. USE THE WORDS "HAM ANTENNAS" OR "ANTENNAS" IN THEIR SEARCH WINDOW TO SEARCH THEIR LIST.

CLICK REFRESH OR RELOAD FOR LATEST UPDATES!

NOTICE:

**THE INFORMATION INCLUDED IN THE ABOVE ARTICLES AND PROJECTS
ARE INTENDED FOR YOUR NON-COMMERCIAL USE ONLY AND ARE FREE AS INTENDED.**

SOME OF THE PROJECTS HOLD A COPYRIGHT BY THE RESPECTIVE DESIGNERS.

**AS WITH ANY PROJECT....USE CAUTION WHEN WORKING AROUND ELECTRICITY. WE CANNOT BE HELD
RESPONSIBLE FOR YOUR ACCIDENTS.**

STAY AWAY FROM POWER LINES!

IF YOU DON'T KNOW WHAT YOU ARE DOING....GET HELP FROM A TRUSTED AND EXPERIENCED HAM FRIEND.

HAVE AN ANTENNA PARTY...NOT A FUNERAL!

BACK TO HAM UNIVERSE

Call your loved ones for only 4.5 cents per minute at LowerMyBills.com. No hidden fees, no monthly charges!

HELP!

INPUT NEEDED

What Ham radio antenna project would you like to see here?

EMAIL NOW!

CQ VHF MAGAZINE IS

BACK!

GET IT NOW!

[Cq Vhf](#)

[Site Disclaimers & Copyright.](#)

Didn't Find It here? Search the Internet!:

powered by **UPDATED!**

"Maybe just a little more height and a little more GAIN!"

electronics.com

PLEASE SUPPORT YOUR

HAM UNIVERSE

This is the only place you will see this notice on this site...

and it does not work here!

MEMBERS ONLY!

If you're a Ham, you're a member.

If you are not a Ham, you are still a member! Have fun!

N4UJW

FLASH!

**NEW SOFTWARE
PROGRAMMER
DEVELOPS
PROGRAM TO
CHANGE YOUR
COMPUTER
MONITOR INTO A
DIGITAL SCANNER!
TAKE YOUR
PICTURE WHILE
ON THE WEB! NO
CAMERA NEEDED!
[CLICK HERE FOR
LIVE DEMO NOW](#)**

NEW!

ERP CHART

**Look up your
Effective
Radiated Power
(ERP)**



[Click Here for Thousands of
Electronic Parts-Related Items and
Accessories](#)

Hungry?

Check out

**a real
Ham!**



**Get away
from it all!**

**Try
Alaska**

NEW

Convert those
measurements!
Metric to Imperial
Imperial to Metric
For your antenna
project!
[Click here!](#)

**The FCC and
60 Meters!**

What's On Sale?

Tons! Find the latest sale
items on sale at RadioShack.



ON THE AIR NOW!

The 17 Meter COAXial MOXON

30 TO 40% SMALLER!

Donate that Portable Shortwave Receiver

You're not using to a U.S. Soldier in Iraq!

The Secrets Behind This Web Site's Success!

A report from you're Webmaster, N4UJW, just released and shipping now.....cheap!

Learn how to get higher ratings on search engines. Check it out!

NEW

440

SLINGSHOT

[Back to Main Site Index](#)

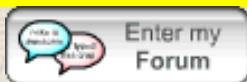

powered by  bravenet.com

NEW!

ANTENNA FORUM

Get those questions answered or
add your input!

Click below to enter.

Note: This is an external service.

We can not be responsible for any
popups or adds.

SITE MAP

Webmasters note:

I Apologize for this very cluttered page!

This web site has grown so fast that I cannot
keep it mowed. The weeds are getting very
tall in places and the grass needs cutting just
about every other day!

Broken antenna elements are scattered all
over, bent towers, burned out baluns, loose
connectors and lots of spiders, useless bits of
wire of all sizes and the accumulation of SWR
is getting awful!

Please be patient.....

We plan to use weed, grass killer and insect
spray so the page should be much neater in the
future! **73** N4UJW.

NEW

KE0VH

DIGITAL

PROJECT



[COAX](#)
[DATA](#)

[The Wonderbar Antenna](#)



Web Hamuniverse.com

[BUILD](#)
[2 METER](#)
[ULTRA](#)
[CHEAP](#)
[ANTENNAS](#)

[Super Gain 40 Meter NVIS Project!](#)

[NEW!](#)
[THE W8AOK](#)
[G5RV](#)
[WALNUT](#)
[TOWER](#)
[PROJECT](#)



[KD6WD MURRAY STATE ARC](#)
[MOXON PROJECT](#)

[eHam.net needs your SUPPORT!](#)



[Monitoring U.S. Homeland Security](#)



VIRUS OR WORM ALERT!

Recently it has been discovered that our email address has been (STOLEN) and used to spread a variant of the Beagle worm.

Normally I do not send random emails with attachments unless you are expecting it.

Please do not open any email from my address with an attachment UNLESS YOU ARE EXPECTING IT!

73 N4UJW HAMUNIVERSE.COM

SITE MAP

THE N3SDO "J" BEAM!

Share your homebrew
antenna project!

[Click here, it's easy!](#)

[Book Home Page](#)

[ARRL Antenna Book](#)

**Grundig Emergency
Home and Portable
Hand Cranked Radio
Review!**

**Grundig Model
FR200**

CRANK IT UP!

[Upgrade your memory straight from the factory. Crucial Technology, The Memory Experts.](#)

DX Zone Web Site

[Amateur Radio and More!](#)

Antenna Magic

by

Ray Jurgens

KQ6RH

(C) 1998, 1999, 2000

Updated 2/25/2000

This page is devoted to light weight wire beams and quad antennas. Most of these antennas are low profile wire beams constructed with fiberglass rods and tubes supported with central hubs. Each of these has been designed to give significant gain over a dipole but require much less space. All are self supported and able to be rotated with low cost TV antenna rotators. This site provides construction details as well as information about where specific materials can be found. We also offer some materials that are difficult to find or make.

Philosophy

You may wonder what the motivation is to try to build antennas with super-light weight structures when larger and heavier structures are readily available. Some might say that this is equivalent to buying into the minimalist movement which, for ham radio, is the same faction as the QRP movement. However, there are many reasons for developing light weight systems for portable and emergency situations as well as relatively stealth applications in controlled spaces such as apartment and town house developments. A few general principles that we have tried to abide by are that each antenna must be self supporting, must be sufficiently light in weight that a single person can easily assemble it and erect it, and that if at all possible, it should be able to give significant gain over a simple dipole. Why settle for less? This is not exactly minimalism, this more in the line of optimism.

Content

This page currently discusses quad-loops, cubic quads, Pfeiffer quads, VK2ABQ wire beams, Reflected M beams, Half Squares, X-Beams and a few simple antennas including a rotatable dipole. The Reflected M beam is a variant of both the VK2ABQ beam and the X-Beam. For a given wavelength, the Reflected M beam is the smallest of all. To compare these, I'll consider the length of the spreader required for a 15 meter antenna cut for 21.2 MHz. Though these differences are small, they are significant in that the bending of the spreader increases as length cubed for an applied force. Thus, the bending of the Reflected M spreader is reduced to 60% of that of a quad loop for a similar wire loading. The Reflected M beam is planar, takes less space to construct and can be designed with performance nearly equal to that of the two element quad. For example, a two element optimized quad might have about 7.5 dBi gain with a F/B ratio of 17 dB. The optimized Reflected M has 6.0 dBi gain with an F/B ratio of near 20 dB, though the actual rear lobes are about 2 dB poorer. The reflected M beam can be assembled and erected in about a half hour. Try that with any quad. I also give the performance of the X-Beam which is similar to and has similar performance as the Reflected M. Though the X-Beam has a good front to back ratio, the front to side lobe ratio is much poorer than that of the Reflected M. Still, the X-Beam is a great antenna that uses aluminum tubing for the radial elements and folded back wires to complete the element lengths rather than using fiberglass and wire, but the Reflected M is better in most respects.

These pages carry a copyright notice. You may make a copy of this web page for your personal use, but you may not distribute it in entirety or any part of it to others without written permission from the owner. You may, of course, pass the URL to others.

Comparing Antennas

The table below give some idea of how each antenna compares to the others. The sizes given are for a 15 meter version of each antenna. The size reported is the required length of the spreader. The impedance of some antennas depends upon several parameters, but the typical values are given below for both free space and ground mounted cases. In the case of the cubic quad, only the two element version is considered in the table. The elevation and peak gain reported are for the first or lowest lobe above an flat earth ground with average properties. For the elevation data, all antennas have their centers set at one half wave length above the ground or about 24.5 feet except for the Quick Vertical which is mounted 3 feet above the ground. The Quick Vertical uses a Hustler whip fed against a counterpoise. The Half Square antenna is actually better at suppressing high angle radiation if it is set at about 18 feet above the ground, but the data given in Table 1 is for 24.5 ft.

| Antenna Type | Size ft | Z Ohms | Gain dBi fspc | F/B ratio | Elev. degrees | Peak Gain dB |
|--------------|---------|----------|------------------|---------------|------------------|-----------------|
| Quad Loop | 8.38 | 130, 125 | 3.2 | 0 dB (bi-dir) | 24 | 7.8 |
| Cubic Quad | 8.38 | 110, 117 | 7.4 | 17.7 | 24 | 11.4 |

| | | | | | | |
|----------------|------|----------|-----|------------------|----|------|
| VK2ABQ beam | 8.45 | 146, 200 | 3.8 | 12.6 | 26 | 9.8 |
| Reflected M | 7.46 | 38, 47 | 4.7 | 11.8 | 26 | 9.8 |
| Reflected M | 7.40 | 22, 24 | 5.8 | 21.8 | 26 | 10.6 |
| Half Square | 11.8 | 48, 50 | 4.4 | 0 dB (bi-dir) | 14 | 3.3 |
| Quick Vertical | 8.0 | 24, 34 | 0.7 | 0 dB (omni-dir) | 24 | -0.9 |
| X-Beam | 9.3 | 34, 33 | 5.7 | 22.9 (deceptive) | 26 | 10.5 |
| Dipole | 11.2 | 71, 65 | 2.1 | 0dB (bi-dir) | 26 | 7.6 |

Table 1

Properties of Various Antennas in Free Space and Elevated a Half Wavelength

Inspection of the table gives some interesting insights:

1. The Reflected M beam has the smaller turning radius and size
2. The only antennas with good matches to 50 Ohm line are the Reflected M and the Half Square
3. The Cubic Quad has the highest free space gain followed by the Reflected M and X-Beam
4. The Reflected M and the Cubic Quad have the best F/B ratios
5. The Half Square wins the low launch angle by a large margin
6. The Cubic Quad has the highest ground mounted gain followed closely by the Reflected M and X-Beam

All of these antennas have respectable performance, and all can be designed with light weight fiberglass construction. So, take a look at these, and pick a winner for your application.

Main Menu

[VK2ABQ wire beams](#)

[Reflected M beams](#)

[Quad Loops](#)

[Light Weight Cubic Quads](#)

[Pfeiffer Quads](#)

[Half Square](#)

[Quickie Vertical](#)

[X-Beams](#)

[Dipoles](#)

[Construction Hints](#)

[Properties of Fiberglass Rods and Tubes](#)

[Our Products](#)

[Suppliers](#)

[KQ6RH Home Page](#)

[Return to Main Menu](#)

LINKS

Check Out KQ6RH's home page. This page contains much information on using Hustler Whips in various configurations for use in mobile, apartments and town houses.

[KQ6RH HOME PAGE](#)

Go directly to Max Gain Systems to check out Fiberglass rods and tubes.

[MAX Gain Systems](#)

Check out the Northern California DX Foundations synchronized beacons.

[NORTHERN CALIFORNIA DX FOUNDATION](#)

Check out the Ionospheric propagation; the following links are useful!

[NOAA Space Weather Links](#)

[NOAA Geomagnetic Indices](#)

[NTIA HF Propagation Models](#)

[NWRA Real Time Sunspot Number](#)

[NWRA IONO Predicts](#)

[NWRA World Wide Ionosonde foF2](#)

[NRL Beacon Scan](#)

055579

AM LOOP ANTENNAS

MOVED ---

--- to its own semi-domain at: http://www.mindspring.com/~loop_antenna. This will hopefully solve the bandwidth problems that shut it down at its former address. Sorry for the inconvenience and re-direction.

**QRZ.COM****Build them again!****MAIN INDEX** 7 Sep 2004 @ 01:43:02 UTC**AES**Your Complete
Ham Radio Store!
1-800-558-0411
www.aesham.com**World's Most
Powerful &
Feature-Filled
Ft-817 & ND
Battery Pack****Kenwood
TS-2000
NOW IN STOCK!****R&L
Electronics
HAMilton, Ohio
800-221-7735****Bunghardt
AMATEUR CENTER
1 (800) 927 4261****E-Z HANG**Great for
Field Day!**Associated
CALL TODAY!
800-497-1457
TOLL FREE!** **RADIO**

Antenna Programs

[Back to the main file index](#)

| Name | Size | Date | Description |
|------------------------------|---------|------------|---|
| 40mbeam.zip | 6964 | 02-02-1998 | Instr. to build a beam for 40 m - K5DKZ |
| antdl6wu.zip | 19040 | 02-02-1998 | Yagi Design for 50 MHz and up |
| antenna.zip | 135028 | 02-02-1998 | UHF/SHF Antenna design |
| antennas.zip | 86768 | 02-02-1998 | Antenna design article collection - KB4YLY |
| antfo.zip | 17237 | 02-02-1998 | Yagi Design prg for 144 MHz and up - WA2TIF |
| ariel15.zip | 32705 | 02-02-1998 | HF wire ant & trans line design v1.5 - WB4YZA |
| ariel30.zip | 27938 | 06-24-1997 | HF wire antenna design program by WB4ZYA |
| asa11.zip | 210312 | 02-02-1998 | Antenna system Analysis v1.1 for Windows |
| azprj104.zip | 1102740 | 06-24-1997 | Postscript files generate az. equidistant |
| bazooka.zip | 11025 | 07-07-1997 | Calc Double bazooka - Win3x/Win95 - W4BEJ |
| coax1.zip | 21630 | 07-07-1997 | Coax calculator for Windows |
| coaxtrap.zip | 578380 | 08-05-1997 | Calc coaxial traps (Win95/NT) - VE6YP |
| dipole.jpg | 80898 | 01-23-2002 | Easy dipole design by AF4NB |
| discone1.zip | 5758 | 02-02-1998 | Discone Antenna Design - K5DKZ |
| esprop14.zip | 146495 | 02-02-1998 | ES-PROP v1.4 Sporadic-E prop analysis prog |
| hamftz03.zip | 48669 | 02-02-1998 | Ionospheric prop prediction program by HB |
| helix_20.zip | 31495 | 02-02-1998 | Helix antenna design - OH0NC |
| jpole.jpg | 49847 | 04-08-1999 | J-pole Design picture |
| jpole.zip | 20052 | 02-02-1998 | J-pole Design Prg V1.1 by WA2ISE |
| jpole1.zip | 15354 | 02-02-1998 | J-pole Design picture - BMP by KI7ZD |
| logyag16.zip | 32083 | 02-02-1998 | Yagi with Log-Cell feeding design - OH0NC |
| loopcalc.zip | 10945 | 09-19-2001 | LoopCalc 1.3 calculate magnetic loop antenna |
| lpda.zip | 7488 | 02-02-1998 | Excel sheet to design Logperiodic Dipoles |
| mast.zip | 33514 | 02-02-1998 | Calculate mast dim. needed v1.0beta - KD4NUE |
| mloop.zip | 8864 | 02-02-1998 | Miniloop 1.1 - Small single turn ant design |
| mloop31.zip | 401268 | 08-05-1997 | Magnetic Loop Ant Design v3.1 - DK1NB |

| | | | |
|------------------------------|---------|------------|---|
| msdsp034.zip | 68563 | 08-13-1997 | Meteor Shower Receive |
| mssof42b.zip | 273222 | 02-02-1998 | Meter-scatter v4.2b - predicts meteor showe |
| mssof42e.zip | 274499 | 02-02-1998 | Meteor-scatter v4.2e - predicts ope |
| mssoft43.zip | 584396 | 08-13-1997 | Meteor Shower transmit and prediction - OH5IY |
| necfpc.zip | 248018 | 02-02-1998 | NEC2 w/32 bit reals (for Powerstations) |
| rfprop.zip | 65575 | 06-24-1997 | Radio Prop calcu. v1.01 for Win3x |
| stress.arc | 15151 | 02-02-1998 | Mechanical design for antennas |
| tl.zip | 31612 | 02-02-1998 | TL Transmatch Calculations v1.7 - N6BV |
| trap01.zip | 4964 | 02-02-1998 | 40/80m trap dipole construction - K5DKZ |
| voawin.zip | 5757997 | 06-24-1997 | Estimate freq coverage hour/month (Win ver) |
| wndipole.zip | 4321 | 02-02-1998 | Dipole calculations for Windows - N4PVU |
| ya101pat.zip | 84786 | 02-02-1998 | Yagi analyzer patch for YA v1.0 |
| yagim311.zip | 693013 | 02-02-1998 | Yagimax 3.11 |

[Main File Index](#)

[Return to the antennas file section.](#)

Welcome to AA3PX's Antenna Page

Dedicated to Harold H. Beverage, other radio Pioneers and fellow enthusiasts with a BIG yard.



My 160 meter vertical.. 80 Ft Shunt feed, top loaded.

[Harold H. Beverage PAGE.....](#)(many photos, maybe slow loading)
[Beverage Antenna Design.....](#)(If you have the space for it)

[Inverted"L" info](#)

[AC6V's Great Ham Page](#)

[G5RV antenna spec's and info](#)

[Nordic Shortwave Center](#)

[AA3SJ's QRP Page](#)

Tip's and Tricks Antenna Construction Info from readers !

(Please E-MAIL me with your Construction Tips and Tricks for posting!)

Interesting places to see

[AM broadcast history site \(very nice\)](#)

[Longwave page](#)

[Nikola Tesla page , Check this out !!!!!](#)

Weather info Observed at

| | |
|---|---|
|  | <p>For more information: Click Here!</p> <p>Observed at: Selinsgrove, PA Click For Forecast!</p> |
|---|---|

[Excellent NOAA Weather Site](#)

[Satellite images](#)



If you have any questions, comments, would like to add a link to this page, or help. Please

contact me :

aa3px at localnet dot com

024316 VISITOR'S

PLEASE CHECK BACK . Any input would be greatly appreciated.

| | | |
|---|---|---|
| <p>JOIN WEBRING</p>  <p>INFORMATION</p> | <p>QSL.net</p> <p>This QSL NET WEB RING site is owned by Welcome to the AA3PX antenna page</p> <p>Want to join the QSL NET WEBRING</p> | <p>QSLNET WEBRING</p>  <p>NEXT SITE</p> |
|---|---|---|

CQ-Contest Mailing List Archives

Search String:

[\[How to search\]](#)

Display:

Description:

Sort:

[\[All Lists\]](#)

- 2004-09: [\[Date\]](#) [\[Thread\]](#)
- 2004-08: [\[Date\]](#) [\[Thread\]](#)
- 2004-07: [\[Date\]](#) [\[Thread\]](#)
- 2004-06: [\[Date\]](#) [\[Thread\]](#)
- 2004-05: [\[Date\]](#) [\[Thread\]](#)
- 2004-04: [\[Date\]](#) [\[Thread\]](#)
- 2004-03: [\[Date\]](#) [\[Thread\]](#)
- 2004-02: [\[Date\]](#) [\[Thread\]](#)
- 2004-01: [\[Date\]](#) [\[Thread\]](#)
- 2003-12: [\[Date\]](#) [\[Thread\]](#)
- 2003-11: [\[Date\]](#) [\[Thread\]](#)
- 2003-10: [\[Date\]](#) [\[Thread\]](#)
- 2003-09: [\[Date\]](#) [\[Thread\]](#)
- 2003-08: [\[Date\]](#) [\[Thread\]](#)
- 2003-07: [\[Date\]](#) [\[Thread\]](#)
- 2003-06: [\[Date\]](#) [\[Thread\]](#)
- 2003-05: [\[Date\]](#) [\[Thread\]](#)
- 2003-04: [\[Date\]](#) [\[Thread\]](#)
- 2003-03: [\[Date\]](#) [\[Thread\]](#)
- 2003-02: [\[Date\]](#) [\[Thread\]](#)
- 2003-01: [\[Date\]](#) [\[Thread\]](#)
- 2002-12: [\[Date\]](#) [\[Thread\]](#)
- 2002-11: [\[Date\]](#) [\[Thread\]](#)
- 2002-10: [\[Date\]](#) [\[Thread\]](#)
- 2002-09: [\[Date\]](#) [\[Thread\]](#)
- 2002-08: [\[Date\]](#) [\[Thread\]](#)
- 2002-07: [\[Date\]](#) [\[Thread\]](#)
- 2002-06: [\[Date\]](#) [\[Thread\]](#)
- 2002-05: [\[Date\]](#) [\[Thread\]](#)

- **2002-04:** [\[Date\]](#) [\[Thread\]](#)
- **2002-03:** [\[Date\]](#) [\[Thread\]](#)
- **2002-02:** [\[Date\]](#) [\[Thread\]](#)
- **2002-01:** [\[Date\]](#) [\[Thread\]](#)
- **2001-12:** [\[Date\]](#) [\[Thread\]](#)
- **2001-11:** [\[Date\]](#) [\[Thread\]](#)
- **2001-10:** [\[Date\]](#) [\[Thread\]](#)
- **2001-09:** [\[Date\]](#) [\[Thread\]](#)
- **2001-08:** [\[Date\]](#) [\[Thread\]](#)
- **2001-07:** [\[Date\]](#) [\[Thread\]](#)
- **2001-06:** [\[Date\]](#) [\[Thread\]](#)
- **2001-05:** [\[Date\]](#) [\[Thread\]](#)
- **2001-04:** [\[Date\]](#) [\[Thread\]](#)
- **2001-03:** [\[Date\]](#) [\[Thread\]](#)
- **2001-02:** [\[Date\]](#) [\[Thread\]](#)
- **2001-01:** [\[Date\]](#) [\[Thread\]](#)
- **2000-12:** [\[Date\]](#) [\[Thread\]](#)
- **2000-11:** [\[Date\]](#) [\[Thread\]](#)
- **2000-10:** [\[Date\]](#) [\[Thread\]](#)
- **2000-09:** [\[Date\]](#) [\[Thread\]](#)
- **2000-08:** [\[Date\]](#) [\[Thread\]](#)
- **2000-07:** [\[Date\]](#) [\[Thread\]](#)
- **2000-06:** [\[Date\]](#) [\[Thread\]](#)
- **2000-05:** [\[Date\]](#) [\[Thread\]](#)
- **2000-04:** [\[Date\]](#) [\[Thread\]](#)
- **2000-03:** [\[Date\]](#) [\[Thread\]](#)
- **2000-02:** [\[Date\]](#) [\[Thread\]](#)
- **2000-01:** [\[Date\]](#) [\[Thread\]](#)
- **1999-12:** [\[Date\]](#) [\[Thread\]](#)
- **1999-11:** [\[Date\]](#) [\[Thread\]](#)
- **1999-10:** [\[Date\]](#) [\[Thread\]](#)
- **1999-09:** [\[Date\]](#) [\[Thread\]](#)
- **1999-08:** [\[Date\]](#) [\[Thread\]](#)
- **1999-07:** [\[Date\]](#) [\[Thread\]](#)
- **1999-06:** [\[Date\]](#) [\[Thread\]](#)
- **1999-05:** [\[Date\]](#) [\[Thread\]](#)
- **1999-04:** [\[Date\]](#) [\[Thread\]](#)
- **1999-03:** [\[Date\]](#) [\[Thread\]](#)

- **1999-02:** [\[Date\]](#) [\[Thread\]](#)
- **1999-01:** [\[Date\]](#) [\[Thread\]](#)
- **1998-12:** [\[Date\]](#) [\[Thread\]](#)
- **1998-11:** [\[Date\]](#) [\[Thread\]](#)
- **1998-10:** [\[Date\]](#) [\[Thread\]](#)
- **1998-09:** [\[Date\]](#) [\[Thread\]](#)
- **1998-08:** [\[Date\]](#) [\[Thread\]](#)
- **1998-07:** [\[Date\]](#) [\[Thread\]](#)
- **1998-06:** [\[Date\]](#) [\[Thread\]](#)
- **1998-05:** [\[Date\]](#) [\[Thread\]](#)
- **1998-04:** [\[Date\]](#) [\[Thread\]](#)
- **1998-03:** [\[Date\]](#) [\[Thread\]](#)
- **1998-02:** [\[Date\]](#) [\[Thread\]](#)
- **1998-01:** [\[Date\]](#) [\[Thread\]](#)
- **1997-12:** [\[Date\]](#) [\[Thread\]](#)
- **1997-11:** [\[Date\]](#) [\[Thread\]](#)
- **1997-10:** [\[Date\]](#) [\[Thread\]](#)
- **1997-09:** [\[Date\]](#) [\[Thread\]](#)
- **1997-08:** [\[Date\]](#) [\[Thread\]](#)
- **1997-07:** [\[Date\]](#) [\[Thread\]](#)
- **1997-06:** [\[Date\]](#) [\[Thread\]](#)
- **1997-05:** [\[Date\]](#) [\[Thread\]](#)
- **1997-04:** [\[Date\]](#) [\[Thread\]](#)
- **1997-03:** [\[Date\]](#) [\[Thread\]](#)
- **1997-02:** [\[Date\]](#) [\[Thread\]](#)
- **1997-01:** [\[Date\]](#) [\[Thread\]](#)
- **1996-12:** [\[Date\]](#) [\[Thread\]](#)
- **1996-11:** [\[Date\]](#) [\[Thread\]](#)
- **1996-10:** [\[Date\]](#) [\[Thread\]](#)
- **1996-09:** [\[Date\]](#) [\[Thread\]](#)
- **1996-08:** [\[Date\]](#) [\[Thread\]](#)
- **1996-07:** [\[Date\]](#) [\[Thread\]](#)
- **1996-06:** [\[Date\]](#) [\[Thread\]](#)
- **1996-05:** [\[Date\]](#) [\[Thread\]](#)
- **1996-04:** [\[Date\]](#) [\[Thread\]](#)
- **1996-03:** [\[Date\]](#) [\[Thread\]](#)
- **1996-02:** [\[Date\]](#) [\[Thread\]](#)
- **1996-01:** [\[Date\]](#) [\[Thread\]](#)

- **1995-12:** [\[Date\]](#) [\[Thread\]](#)
- **1995-11:** [\[Date\]](#) [\[Thread\]](#)
- **1995-10:** [\[Date\]](#) [\[Thread\]](#)
- **1995-09:** [\[Date\]](#) [\[Thread\]](#)
- **1995-08:** [\[Date\]](#) [\[Thread\]](#)
- **1995-07:** [\[Date\]](#) [\[Thread\]](#)
- **1995-06:** [\[Date\]](#) [\[Thread\]](#)
- **1995-05:** [\[Date\]](#) [\[Thread\]](#)
- **1995-04:** [\[Date\]](#) [\[Thread\]](#)
- **1995-03:** [\[Date\]](#) [\[Thread\]](#)
- **1995-02:** [\[Date\]](#) [\[Thread\]](#)
- **1995-01:** [\[Date\]](#) [\[Thread\]](#)
- **1994-12:** [\[Date\]](#) [\[Thread\]](#)
- **1994-11:** [\[Date\]](#) [\[Thread\]](#)
- **1994-10:** [\[Date\]](#) [\[Thread\]](#)
- **1994-09:** [\[Date\]](#) [\[Thread\]](#)
- **1994-08:** [\[Date\]](#) [\[Thread\]](#)
- **1994-07:** [\[Date\]](#) [\[Thread\]](#)
- **1994-06:** [\[Date\]](#) [\[Thread\]](#)
- **1994-05:** [\[Date\]](#) [\[Thread\]](#)
- **1994-04:** [\[Date\]](#) [\[Thread\]](#)
- **1994-03:** [\[Date\]](#) [\[Thread\]](#)
- **1994-02:** [\[Date\]](#) [\[Thread\]](#)
- **1994-01:** [\[Date\]](#) [\[Thread\]](#)
- **1993-12:** [\[Date\]](#) [\[Thread\]](#)
- **1993-11:** [\[Date\]](#) [\[Thread\]](#)
- **1993-10:** [\[Date\]](#) [\[Thread\]](#)
- **1993-09:** [\[Date\]](#) [\[Thread\]](#)
- **1993-08:** [\[Date\]](#) [\[Thread\]](#)
- **1993-07:** [\[Date\]](#) [\[Thread\]](#)
- **1993-06:** [\[Date\]](#) [\[Thread\]](#)
- **1993-05:** [\[Date\]](#) [\[Thread\]](#)
- **1993-04:** [\[Date\]](#) [\[Thread\]](#)
- **1993-03:** [\[Date\]](#) [\[Thread\]](#)
- **1993-02:** [\[Date\]](#) [\[Thread\]](#)
- **1993-01:** [\[Date\]](#) [\[Thread\]](#)
- **1992-12:** [\[Date\]](#) [\[Thread\]](#)
- **1992-11:** [\[Date\]](#) [\[Thread\]](#)

- **1992-10:** [\[Date\]](#) [\[Thread\]](#)
- **1992-09:** [\[Date\]](#) [\[Thread\]](#)
- **1992-08:** [\[Date\]](#) [\[Thread\]](#)
- **1992-07:** [\[Date\]](#) [\[Thread\]](#)
- **1992-06:** [\[Date\]](#) [\[Thread\]](#)
- **1992-05:** [\[Date\]](#) [\[Thread\]](#)
- **1992-04:** [\[Date\]](#) [\[Thread\]](#)
- **1992-03:** [\[Date\]](#) [\[Thread\]](#)
- **1992-02:** [\[Date\]](#) [\[Thread\]](#)

[\[All Lists\]](#)

Towertalk Mailing List Archives

Search String:

[\[How to search\]](#)

Display:

Description:

Sort:

[\[All Lists\]](#)

- 2004-09: [\[Date\]](#) [\[Thread\]](#)
- 2004-08: [\[Date\]](#) [\[Thread\]](#)
- 2004-07: [\[Date\]](#) [\[Thread\]](#)
- 2004-06: [\[Date\]](#) [\[Thread\]](#)
- 2004-05: [\[Date\]](#) [\[Thread\]](#)
- 2004-04: [\[Date\]](#) [\[Thread\]](#)
- 2004-03: [\[Date\]](#) [\[Thread\]](#)
- 2004-02: [\[Date\]](#) [\[Thread\]](#)
- 2004-01: [\[Date\]](#) [\[Thread\]](#)
- 2003-12: [\[Date\]](#) [\[Thread\]](#)
- 2003-11: [\[Date\]](#) [\[Thread\]](#)
- 2003-10: [\[Date\]](#) [\[Thread\]](#)
- 2003-09: [\[Date\]](#) [\[Thread\]](#)
- 2003-08: [\[Date\]](#) [\[Thread\]](#)
- 2003-07: [\[Date\]](#) [\[Thread\]](#)
- 2003-06: [\[Date\]](#) [\[Thread\]](#)
- 2003-05: [\[Date\]](#) [\[Thread\]](#)
- 2003-04: [\[Date\]](#) [\[Thread\]](#)
- 2003-03: [\[Date\]](#) [\[Thread\]](#)
- 2003-02: [\[Date\]](#) [\[Thread\]](#)
- 2003-01: [\[Date\]](#) [\[Thread\]](#)
- 2002-12: [\[Date\]](#) [\[Thread\]](#)
- 2002-11: [\[Date\]](#) [\[Thread\]](#)
- 2002-10: [\[Date\]](#) [\[Thread\]](#)
- 2002-09: [\[Date\]](#) [\[Thread\]](#)
- 2002-08: [\[Date\]](#) [\[Thread\]](#)
- 2002-07: [\[Date\]](#) [\[Thread\]](#)
- 2002-06: [\[Date\]](#) [\[Thread\]](#)
- 2002-05: [\[Date\]](#) [\[Thread\]](#)

- **2002-04:** [\[Date\]](#) [\[Thread\]](#)
- **2002-03:** [\[Date\]](#) [\[Thread\]](#)
- **2002-02:** [\[Date\]](#) [\[Thread\]](#)
- **2002-01:** [\[Date\]](#) [\[Thread\]](#)
- **2001-12:** [\[Date\]](#) [\[Thread\]](#)
- **2001-11:** [\[Date\]](#) [\[Thread\]](#)
- **2001-10:** [\[Date\]](#) [\[Thread\]](#)
- **2001-09:** [\[Date\]](#) [\[Thread\]](#)
- **2001-08:** [\[Date\]](#) [\[Thread\]](#)
- **2001-07:** [\[Date\]](#) [\[Thread\]](#)
- **2001-06:** [\[Date\]](#) [\[Thread\]](#)
- **2001-05:** [\[Date\]](#) [\[Thread\]](#)
- **2001-04:** [\[Date\]](#) [\[Thread\]](#)
- **2001-03:** [\[Date\]](#) [\[Thread\]](#)
- **2001-02:** [\[Date\]](#) [\[Thread\]](#)
- **2001-01:** [\[Date\]](#) [\[Thread\]](#)
- **1999-12:** [\[Date\]](#) [\[Thread\]](#)
- **1999-11:** [\[Date\]](#) [\[Thread\]](#)
- **1999-10:** [\[Date\]](#) [\[Thread\]](#)
- **1999-09:** [\[Date\]](#) [\[Thread\]](#)
- **1999-08:** [\[Date\]](#) [\[Thread\]](#)
- **1999-07:** [\[Date\]](#) [\[Thread\]](#)
- **1999-06:** [\[Date\]](#) [\[Thread\]](#)
- **1999-05:** [\[Date\]](#) [\[Thread\]](#)
- **1999-04:** [\[Date\]](#) [\[Thread\]](#)
- **1999-03:** [\[Date\]](#) [\[Thread\]](#)
- **1999-02:** [\[Date\]](#) [\[Thread\]](#)
- **1999-01:** [\[Date\]](#) [\[Thread\]](#)
- **1998-12:** [\[Date\]](#) [\[Thread\]](#)
- **1998-11:** [\[Date\]](#) [\[Thread\]](#)
- **1998-10:** [\[Date\]](#) [\[Thread\]](#)
- **1998-09:** [\[Date\]](#) [\[Thread\]](#)
- **1998-08:** [\[Date\]](#) [\[Thread\]](#)
- **1998-07:** [\[Date\]](#) [\[Thread\]](#)
- **1998-06:** [\[Date\]](#) [\[Thread\]](#)
- **1998-05:** [\[Date\]](#) [\[Thread\]](#)
- **1998-04:** [\[Date\]](#) [\[Thread\]](#)
- **1998-03:** [\[Date\]](#) [\[Thread\]](#)

- **1998-02:** [\[Date\]](#) [\[Thread\]](#)
- **1998-01:** [\[Date\]](#) [\[Thread\]](#)
- **1997-12:** [\[Date\]](#) [\[Thread\]](#)
- **1997-11:** [\[Date\]](#) [\[Thread\]](#)
- **1997-10:** [\[Date\]](#) [\[Thread\]](#)
- **1997-09:** [\[Date\]](#) [\[Thread\]](#)
- **1997-08:** [\[Date\]](#) [\[Thread\]](#)
- **1997-07:** [\[Date\]](#) [\[Thread\]](#)
- **1997-06:** [\[Date\]](#) [\[Thread\]](#)
- **1997-05:** [\[Date\]](#) [\[Thread\]](#)
- **1997-04:** [\[Date\]](#) [\[Thread\]](#)
- **1997-03:** [\[Date\]](#) [\[Thread\]](#)
- **1997-02:** [\[Date\]](#) [\[Thread\]](#)
- **1997-01:** [\[Date\]](#) [\[Thread\]](#)
- **1996-12:** [\[Date\]](#) [\[Thread\]](#)
- **1996-11:** [\[Date\]](#) [\[Thread\]](#)
- **1996-10:** [\[Date\]](#) [\[Thread\]](#)
- **1996-09:** [\[Date\]](#) [\[Thread\]](#)
- **1996-08:** [\[Date\]](#) [\[Thread\]](#)
- **1996-07:** [\[Date\]](#) [\[Thread\]](#)
- **1996-06:** [\[Date\]](#) [\[Thread\]](#)

[\[All Lists\]](#)

Common Antennas For Portable Use

Lots of speculation goes into antennas for portable use. There are conflicts. On the one hand you need to cart all the stuff with you so there is a definite "less is more" attitude here. On the other hand, putting up a "dummy load" does no one any good. As it turns out, height of the pole or poles available in wavelength determines just about everything in the selection process.

Several basic types are compared here using EZnec software. One is a very highly optimized vertical. It uses 16 elevated radials 28 inches off the ground. It uses lots of segments and is carefully matched to the EZnec model to make as certain as possible that it is free of computational artifacts.

The second is a classic dipole erected using about the maximum length of pole that can be easily packed or taken on an airplane, a pair of multi-segment 16 foot poles. The third is a classic inverted V with an apex angle of 90 degrees. Another was modeled with an apex angle of 120 degrees but it had a large footprint due to the long guy wires. It was a tiny bit better at the flatter angle. The final one was an interesting fan dipole with triangular wire elements that were 24 inches wide at the far end. All used the same pole height.

The shock was the vertical. First look at the great pattern!:

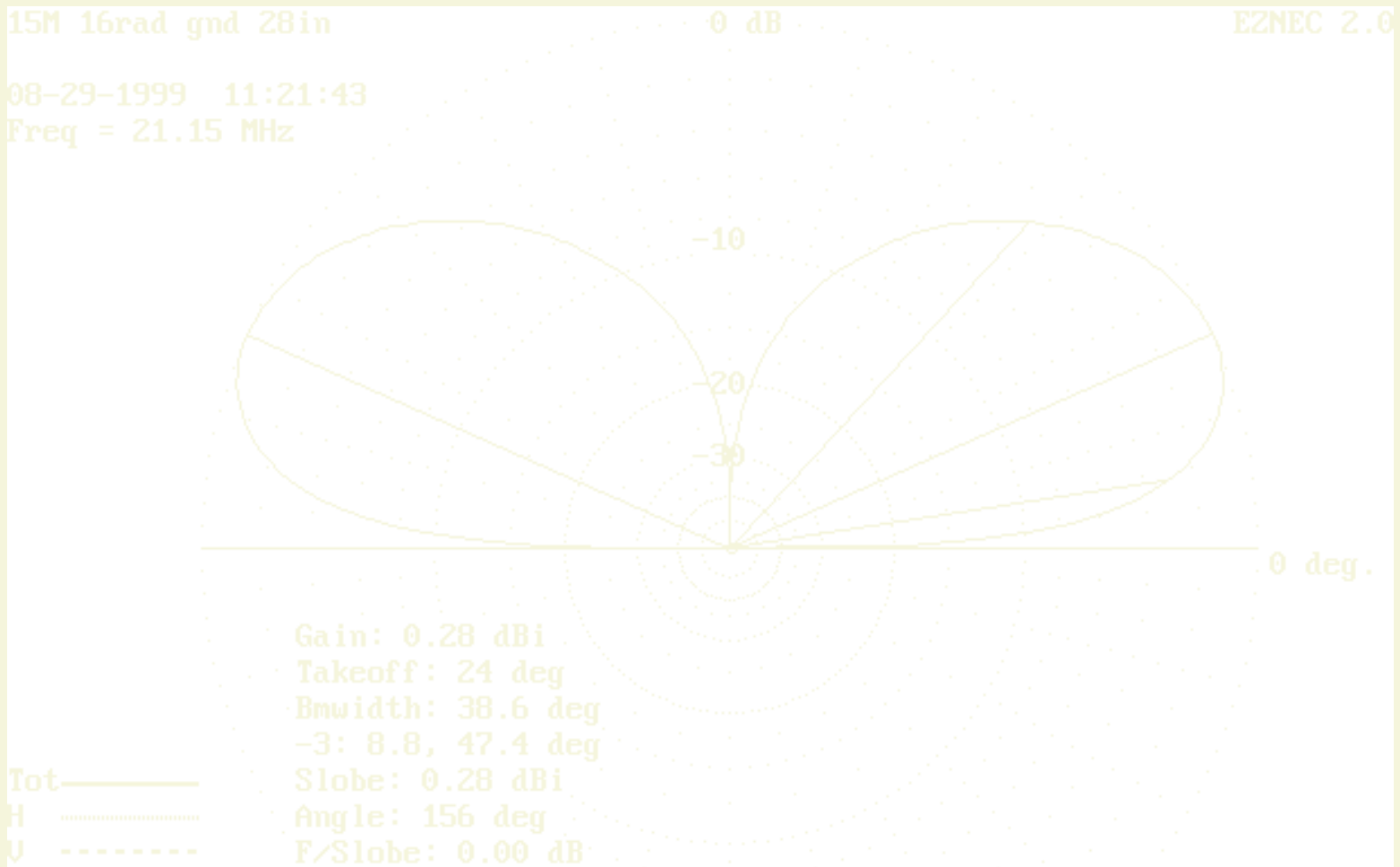

This looks **REALLY** good. It should. Everything that can be done has been done. This design brings along 16 additional stakes each about 3 feet long, to hold up the 16 elevated radials, but it is self supporting and needs no guy wires other than those on the 16 stakes for the elevated radials. Look at the nice concentration of power in the low angles, something a vertical is famous for. This one is getting close to the pattern over perfect ground.

Let's look at the pattern of the dipole. Who in their right mind would cart along two 16 foot poles instead of the above antenna. You could even get away with not elevating the above radials and laying them out on the ground as long as you used 16 or more of them, and still get much the same performance as above. But here is the dipole pattern:

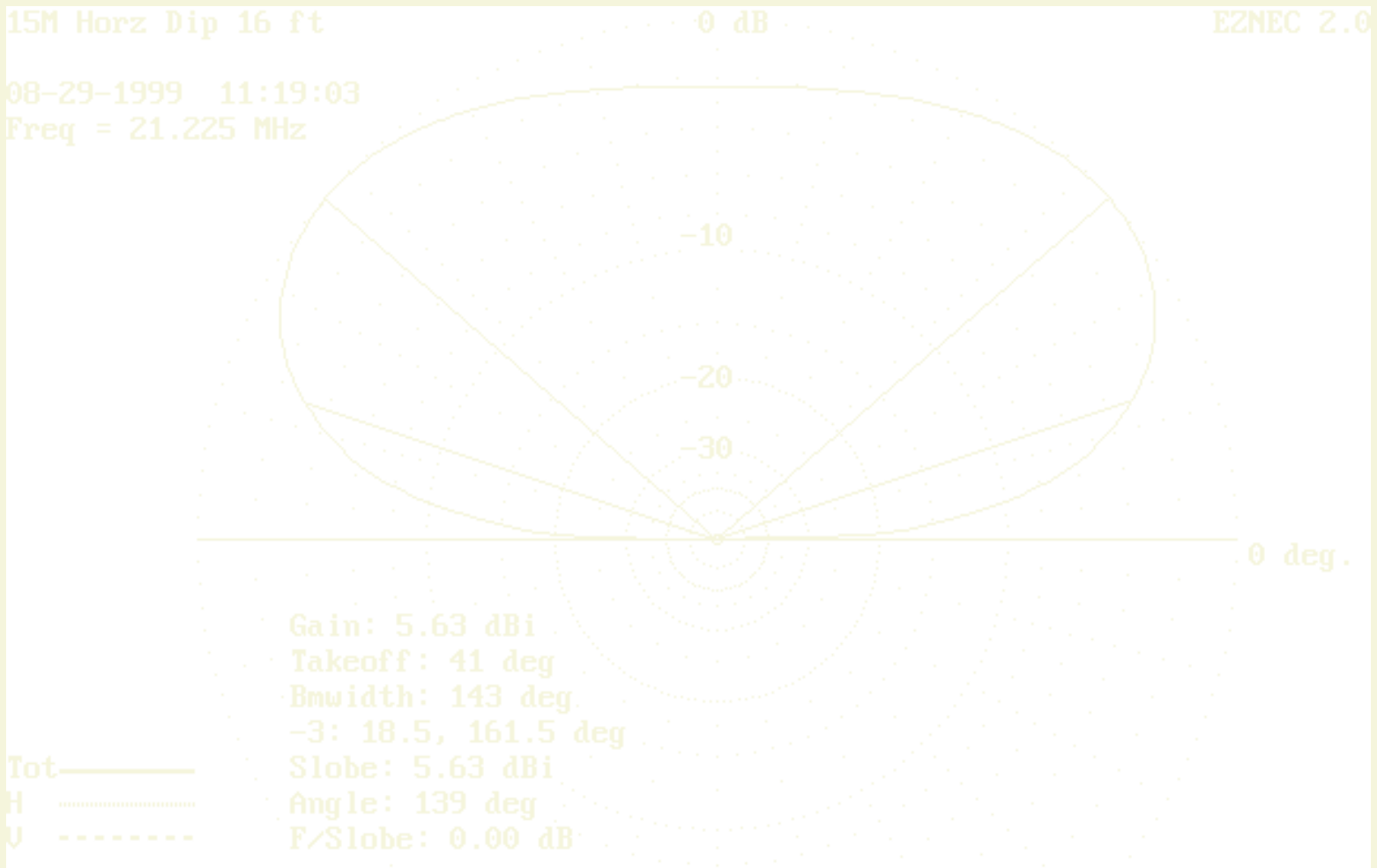

Not much to look at compared to the beautiful vertical pattern above. But there is something to look very very carefully at here. The absolute values. All of these antennas were modeled on 5 millisiemen ground and in each case the support poles were modeled as well as grounded metal poles. Note that the presence of the poles made only a slight difference in the patterns and gain figures. All antennas were carefully resonated at the test frequency.

So what is wrong? Let's have a look at the two patterns scaled and plotted on top of each other:

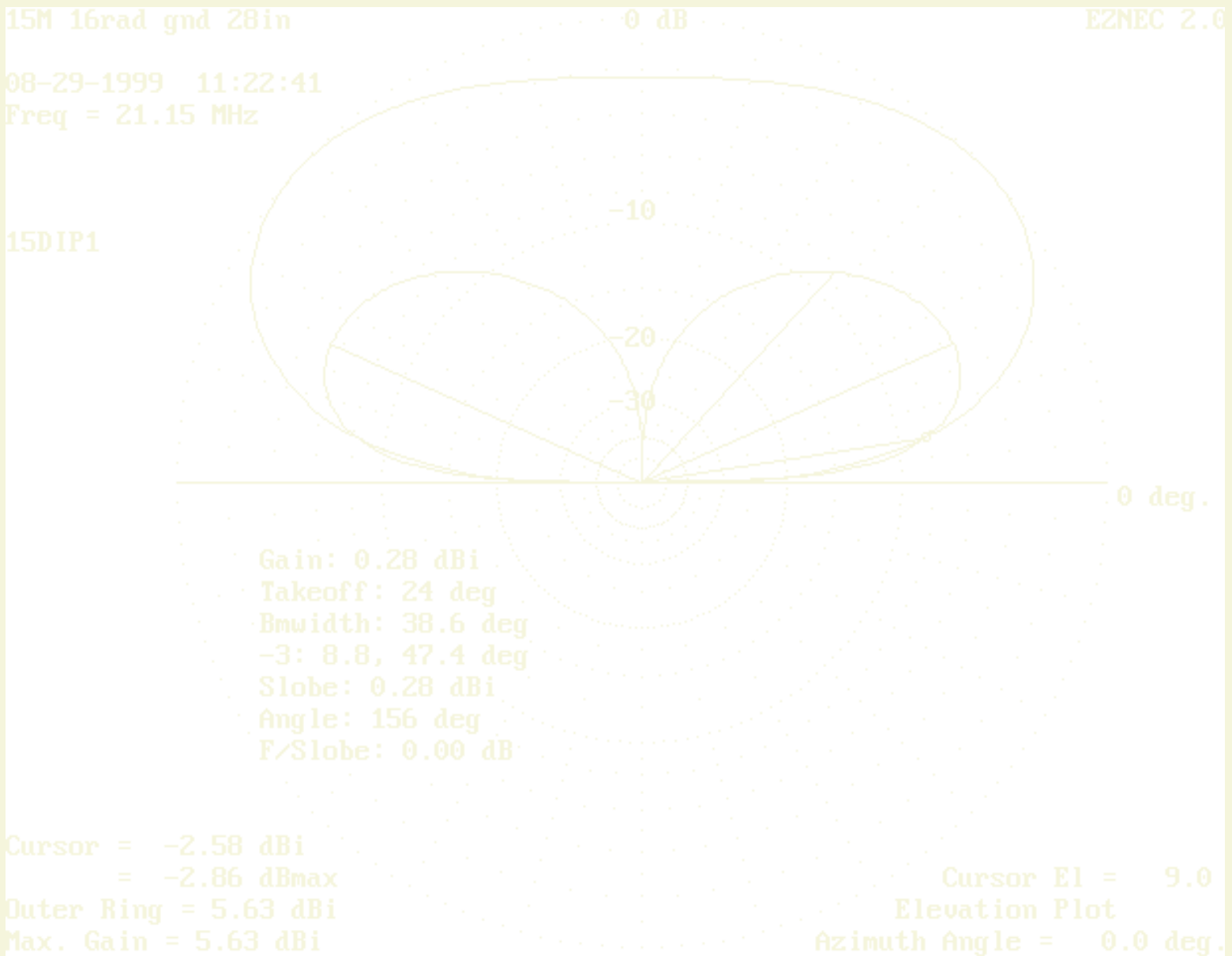

Oops. Suddenly the dipole does not look so bad. In fact, there is only a very tiny portion of the patterns, below 9 degrees, where the vertical is better than the dipole and there only by the smallest of fractions of a db. The vertical pattern is a subset of the dipole pattern. At angles like 15 degrees, a solid DX angle, the dipole is considerably better. And this dipole is only mounted about 3/8th wave above the ground.

The fan dipole was fun. It was of course shorter between poles than the regular dipole and seemed to have a slightly better gain figure vs. the dipole. Perhaps it had a bit bigger capture area:

Portable Fan Dipole

0 dB

EZNEC 2.0

08-29-1999 11:24:28

Freq = 21.225 MHz

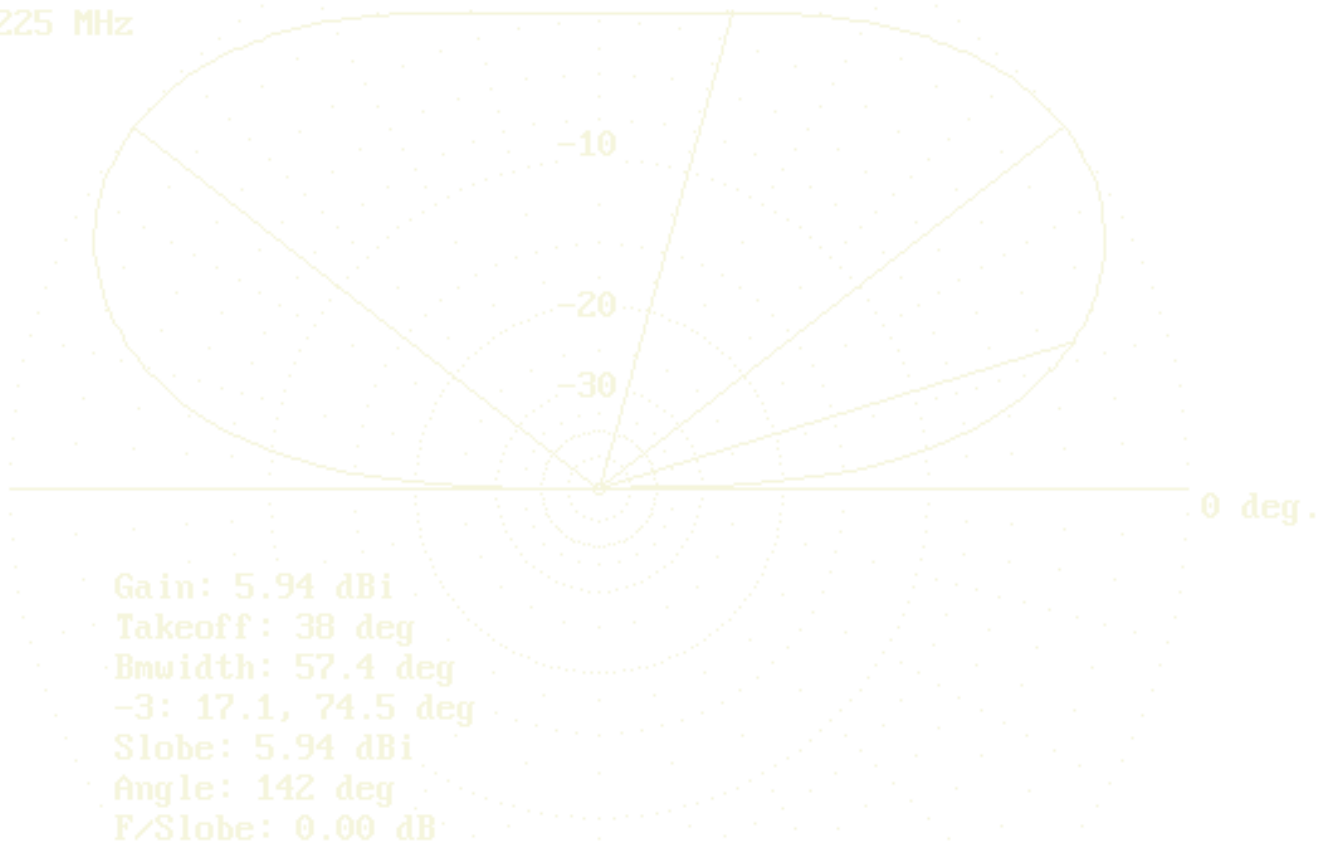

But notice the great similarity to the regular dipole. This is a cute antenna. It has one advantage. Since it assumes a slight droop in the upper wire, it supports the coax better than the regular dipole. The regular dipole was modeled with a droop due to coax or feed line weight. With an upward angle of 5 degrees on each side if center. This made a slight improvement in the pattern of the regular dipole.

So we decided to simplify things. With an inverted V you only need one support. Half the things to drag along. But there is a serious problem. As soon as the dipole started to droop a significant amount downwards at the ends, cancellation attacked. The sad truth is the inverted V is probably a bit worse than the vertical:

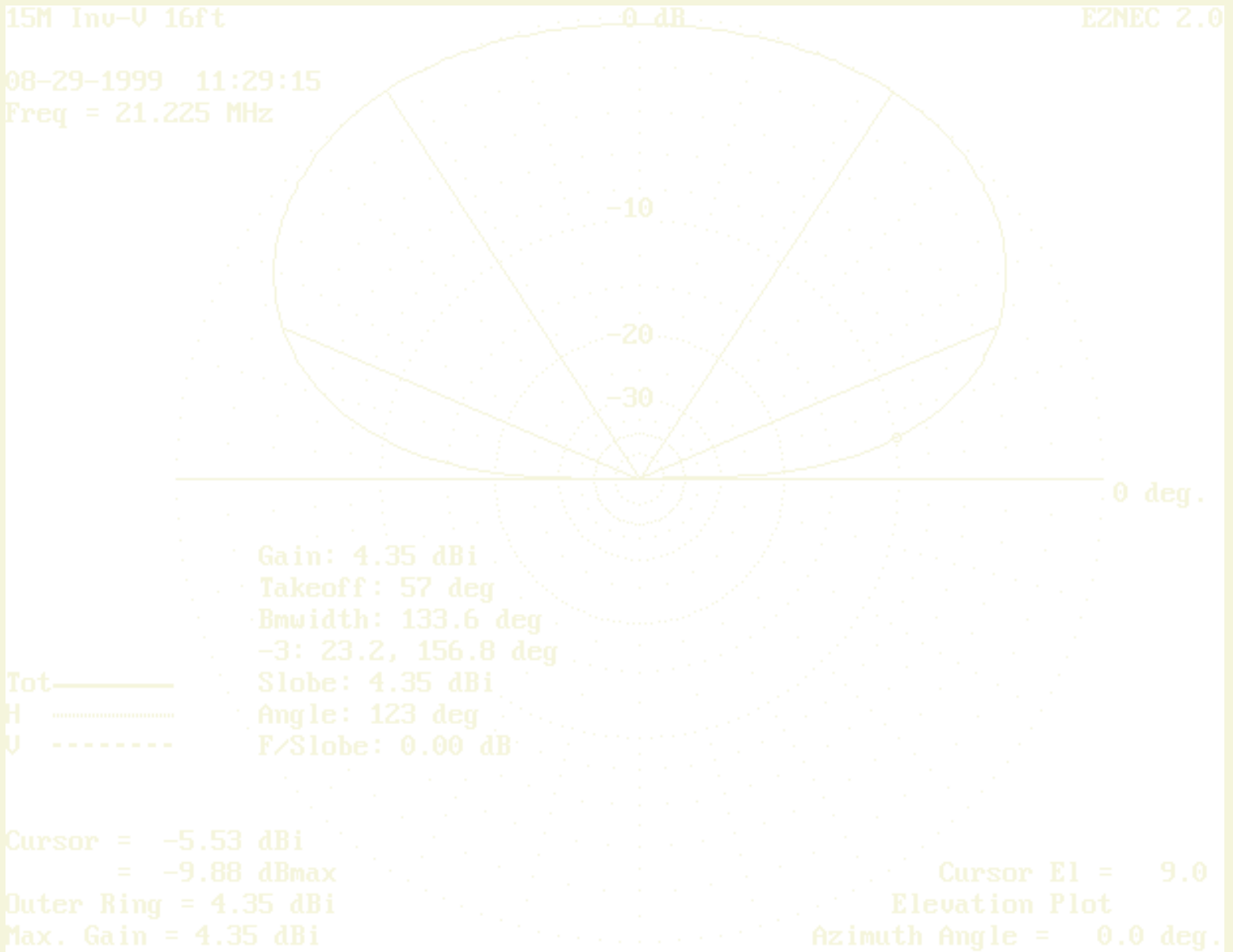

Let's compare the two on the same scale on the same plot:

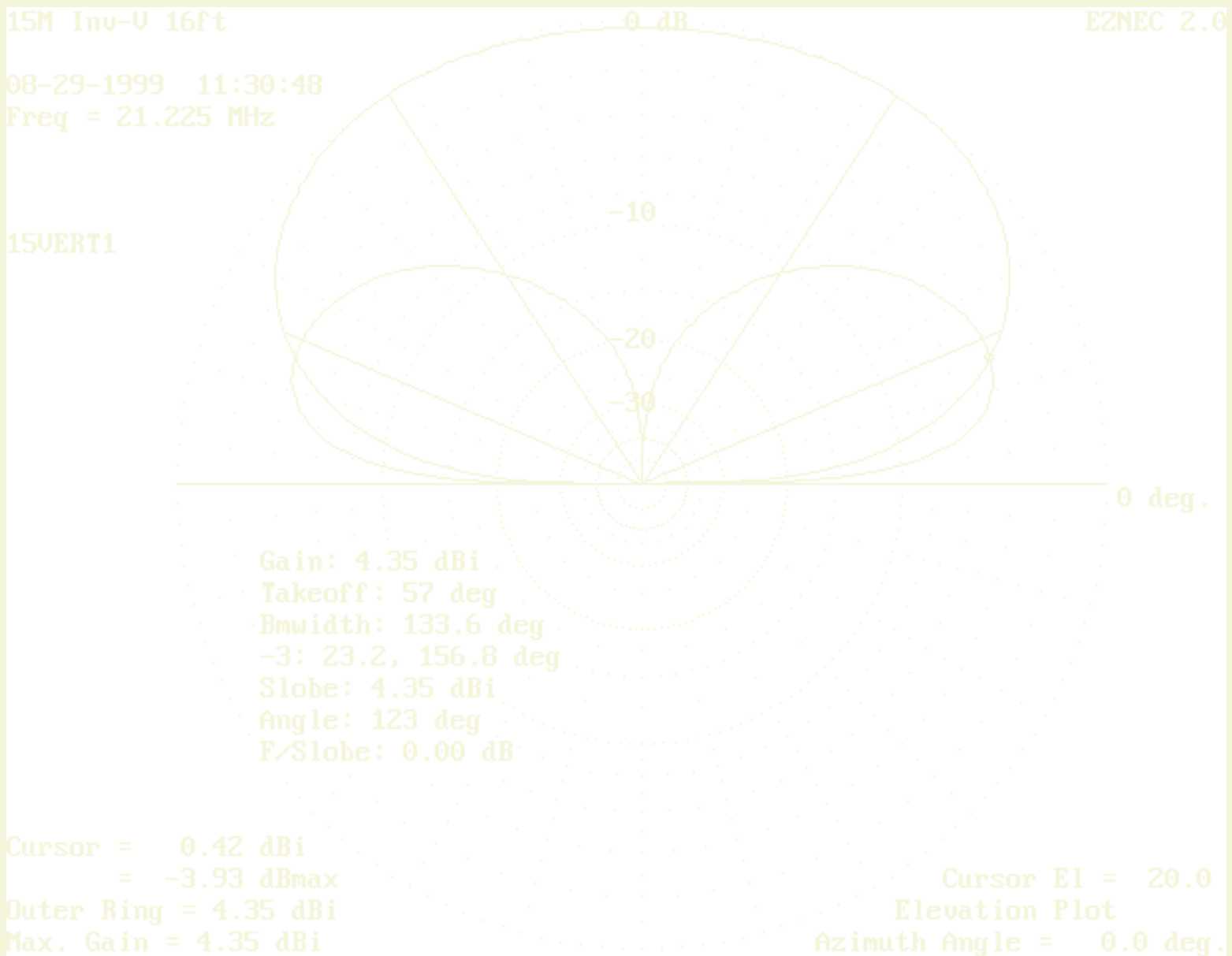

Note that below 20 degrees the vertical is better, enough better to call it significant perhaps. So, the sorry truth is that in spite of how pretty the vertical pattern is, and how nice it looks, and how primitive the old center fed dipole is with its simplicity, the dipole appears to be the best selection.

So why the great reputation of the vertical as a DX antenna? Probably for what it throws away. The pattern of the vertical will make it reject signals coming via NVI and high angle skip. This means it will reject signals from 50 miles to 400 or so miles out. If you live in California this means that lots of DX signals buried in local QRM might suddenly become readable as the vertical rejects the local stuff in favor of the low angle signals.

The vertical with ground laid radials is easy to set up and self supporting. When done this way it is a compact antenna to take along. The problem comes when you try to do better. You can use a pair of verticals and phase them. But then you have the same double hardware of the two poles supporting the dipole. The final sorry result is that phasing verticals is a bit tricky for best gain, you need lots of radials under both verticals to get them to work well and you might get about 3 dBi gain. The dipole is very easy to set up and tune and get the predicted performance out of. And it may well outperform your fancy two phased verticals unless you get them just right.

The support poles can be quite light, of nesting aluminum, relying on small guy wires. The dipole itself can be designed to be as light as possible as well to reduce strain on the poles. 16 feet should be quite manageable with careful design, making a bundle short enough to qualify as "fishing rods" a category recognized by airlines.

Finally, one last look, this time at the Fan Dipole vs. the optimized 1/4 wave vertical with 16 elevated radials. The cursor is placed at the intersection of the two figures and the lower left hand corner has the gain at that point:

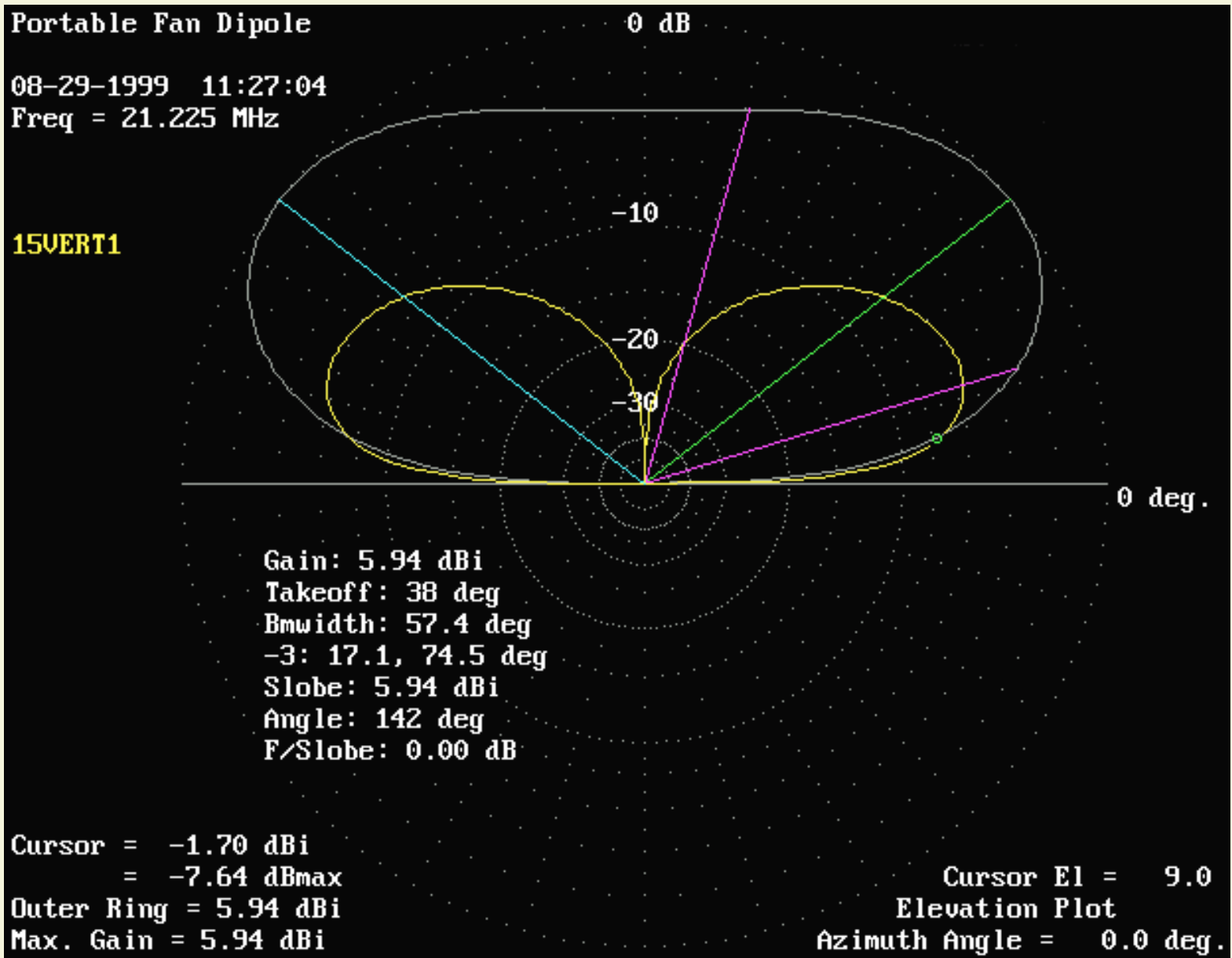

In summary:

At one half wave above ground, a simple resonant dipole will significantly outperform the best installed 1/4 or 5/8 wave vertical.

At one quarter wave above ground, A simple resonant dipole will outperform a quarter wave vertical for NVI or local communication. The vertical if well installed over a decent ground structure, will outperform the dipole

for radiation angles less than 30 degrees.

Below one quarter wave above ground, the simple resonant dipole will suffer significant losses, but still outperform a quarter wave vertical for NVI operation. Even a shortened loaded vertical, well installed, will outperform this low mounted dipole for radiation angles below 30 degrees.

An inverted V has both problems, the self cancellation of a vertical and the low mount pattern distortion of a dipole. But at 1/4 wave center mounting height it would be a good compromise between a quarter wave vertical and a horizontal resonant dipole. It would be much easier to make efficient if one is not judicious about the ground screen creation for the vertical.

Thus selection depends entirely on the height available and the number of supports. With two supports 1/2 wave tall, a resonant dipole, especially a fan dipole, will outperform the vertical in all cases.

With less than 1/2 wave of support/vertical pole, a carefully installed vertical will outperform the dipole for DX, but be much less useful for local NVI communications.

The inverted V includes the worst of everything, and is thus generally useful with a single 1/4 to 1/2 wave center support.

[Return to UH Ham Club Home Page](#)

05/00



YANKEE CLIPPER CONTEST CLUB

[Home](#)

Articles

These include interesting tidbits written or uncovered by YCCC members.

First Annual DXpedition Award Program ([MSWord](#)) ([PDF](#))

[Award Policy \(txt\)](#)

[Award Application \(txt\)](#)

by Jim McCobb, W1LLU

Log Analysis

[80M Log Analysis \(PPT\)](#)

by David Jordan, K1NQ

[Statistical Log Analysis Using Power to Determine Capability \(Rev 1\) \(PDF\)](#) **NEW**

by David Jordan, K1NQ

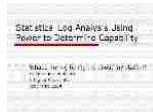

Antennas and Propagation

[Compact wire Tri-band Yagi for 10 -15m \(HTML\)](#)

by David Jordan, K1NQ (updated 22-Mar-2004)

[10/15 M Dual Band Dual feed 26-foot](#)



[Boom \(PDF\)](#)

by David Jordan, K1NQ

[What is VOACAP Trying to Tell Me? \(PDF\)](#)

by Dean Straw, N6BV

[Why We Stack 'Em - Covering All the Angles \(PDF\)](#)

[Home](#)
[Articles](#)
[On Air Activities](#)
[YCCC Web Links](#)
[Resources](#)
[Meetings](#)
[Scuttlebutt](#)
[About YCCC](#)
[Site News](#)
[Members Only](#)

by Dean Straw, N6BV

[Thrust Bearing FAQs](#) (MSWord) - Hints and Kinks for your thrust bearings

Compiled by Fred Hopengarten, K1VR

[Double-L For 80/160](#) (HTML)

by Don Toman, K2KQ

[Two Wire Beverage](#) (HTML)

by Jeff Parker, KA1GJ

Four-Square Antennas

Four Square Experiences ([PDF](#)) ([HTML](#))

by Jack Schuster, W1WEF and Tom Frenaye, K1KI

[Using a 4 square Vertical Phased Array to improve your 80 and 160 meter signal - without a Yagi!](#) (HTML)

by Tom Frenaye, K1KI

[FVR Spitfire - A Poor Man's 160 Meter 4-Square](#) (HTML/PPT)

by Fred Hopengarten, K1VR and John Kaufman, W1FV

[FVR Spitfire FAQs](#) (MSWord)

by Fred Hopengarten, K1VR and John Kaufman, W1FV

Equipment

[Improving the AL-1200 Relay Speed](#) (HTML)

by Tony Brock-Fisher, K1KP

Operating and Tactics

[The Thrill of it All](#) (PDF) - Contesting isn't just for contesters (from QST) by Jack Schuster, W1WEF

[Contesting Phrases](#) (HTML) - Several contesting phrases are given in several languages

by Fred Hopengarten, K1VR

[Sleep Deprivation Strategies](#) (HTML) - minutes from 1988 presentation by Dr. Scott Johnson, NW1I - edited by Charlotte Richardson, KQ1F and Fred Hopengarten, K1VR

[A Sleep Strategy for DX Contests](#) - Randy Thompson, K5ZD

Dayton 1999 - Two Views

[YCCC At Dayton \(HTML\)](#) by Jeff Briggs, K1ZM

[Dayton 1999 Recollections \(HTML\)](#) by Jack

Schuster, W1WEF

[CQWW CW Recollections \(HTML\)](#) by Jack Schuster, W1WEF

[IARU 97 CW \(HTML\)](#) by Jack Schuster, W1WEF

[A Photo Tour of W1KM \(HTML\)](#) by Tom Frenaye, K1KI

[K1KI Station Profile and Pictures \(HTML\)](#) by Tom Frenaye,
K1KI

[[Home](#)] [[Articles](#)] [[On Air Activities](#)] [[YCCC Web Links](#)] [[Resources](#)] [[Meetings](#)]
[[Scuttlebutt](#)] [[About YCCC](#)] [[Site News](#)] [[Members Only](#)]

[Articles/footer_include.htm]



Antenna System Evaluator

This JavaScript program evaluates the performance of your antenna system, computing the consequences of SWR and feedline loss. 73 de Ron

JavaScript PROGRAM by n6ach@comcast.net
original program concept done in CPM basic by KC6A and N6NB.

[Translate this page automatically.](#) 

| | |
|--|--|
| power from xmitter in watts | -1VSWR @ xmitter |
| feed line loss in db(must be in line with other values) | Antenna gain in dBi: Enter 2.2 for dipoles; add 2.2 for antennas rated in dBd |

-

| | |
|-------------------------------------|---|
| reverse power at xmitter | -1VSWR @ antenna |
| forward power in watts at antenna | reflected power in watts from the antenna |
| true power in watts into antenna | power in watts lost in feed line |
| db line loss including vswr effects | EIRP in watts |

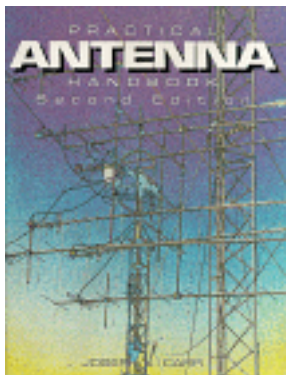

[Order Practical Antenna Handbook by Joseph J. Carr Today!](#)

[Order Antenna Theory and Design:](#)

A book on principles and development techniques for examining and designing antenna systems. Emphasis is on basic topics and applications, and much material does not rely heavily on mathematics.

LINKS:

| | |
|--|---------------------------------|
| <u>QUAD ANTENNA CALCULATOR</u> | |
| <u>RF Saftey Calculator</u> | |
| | <u>Site map</u> |

If you have any questions, comments or you want to see something else added please e-mail me at n6ach@comcast.net

73 de Ron



07-09-04

n6ach@comcast.net





3.5 Million Hits

antenneX

Amateur Radio

The Magazine All About Antennas

**PUBLISHED
MONTHLY**

The paper magazine that was read in 45 countries!

Now this online version reaches 190 countries!

[Click Here to See List](#)

~ September 2004 ~ Online Issue No. 89 ~

Main

About Us

View Free

Downloads

Read Rooms

Subscribe

Shopping

Forums

Write for Us

FAQ

Feedback

~ In This Issue ~

- Build a CCD
- Extend the 2-M OWA Family
- Yagi-Uda 2M 12-L Beam
- Grounded Horizontal Loop
- The Biloop & No Capacitor
- New Maxwell Equations Evidence
- [Read Stone's Throw! for News ~ Click Here!](#)
- [Join the Antenna Discussion List ~ Click Here!](#)

Orthogonal Currents & Tangential Magnetic Fields

Experimental Evidence

By
William Miller
And
Werner Hödlmayr



• [Read Stone's Throw! for News ~ Click Here!](#)

• [Join the Antenna Discussion List ~ Click Here!](#)

antenneX
on
CD-ROM



Basic Antenna Modeling
Exercise Models
in .EZ Format



Ver. 1.0

06: 45: 33 PM
Sep 6, 104

Read Our Monthly Columns!

[Antenna Modeling](#)



This is a regular and popular monthly column by **L.B. Cebik, W4RNL**. Because computerized antenna modeling has become widespread, and its popularity as a design tool continues to increase, this series is devoted to helping readers get the most from the design software used. The articles focus upon the use of NEC and MININEC, along with useful adjunct software as well.

[From The Shack](#)

This column is primarily for "Guest Editorials" to provide a podium for our readers to voice their opinions to the rest of the world too. This is a chance for readers to get on their "soapbox" and speak about antenna and radio-related subjects. Don't miss these interesting views about anything and everything about radio and antenna systems! Now, what have YOU to say??

[Ham WorkShop](#)

Ham WorkShop, is also another regular monthly column filled with a variety of "RADIO-STUFF" of value to almost everyone in amateur radio from Novice to Extra and those just beginning to take up this special hobby. This includes subjects, but not limited to: VHF, choosing the right antenna, coax cable, small to mid-scale construction projects in a practical manner, use of test equipment, etc. It is also meant to help readers become more familiar with the technical jargon *and* the fun side of radio.

[Stone's Throw!](#)



Stone' Throw! a monthly column by *antenneX* publisher, **Jack L. Stone**, among other things, is to keep the readers informed about our progress, new developments, plans for the future, and to introduce the authors and their subjects each month. Also, our main slogan around here is "we aim to please", so this serves as a place for the readers to tell the publisher what is wanted or at least make suggestions. Just remember, the publisher is only a **Stone's Throw** away! Go in for a visit and read this month's column.

[Propagation](#)

Propagation another monthly column by Marcel H. De Canck, ON5AU of Belgium. Signal propagation is a subject that is one of the most basic ingredients of radio and is something everyone in radio should know about in order to maximize communications in the most effective way. It's not enough to have the best equipment and the best antenna if you are trying to send out a signal against a brick wall. Conversely, one may possess a very crude rig, running low power, but yet transmit/receive a signal to great distances with ease, simply by making use of a thorough knowledge about how signal propagation works within the environment. Follow this column and learn more about propagation!



FEATURE ARTICLES THIS MONTH IN THE LIBRARY

Subscription Required to View

[Click to Subscribe](#)

Extending the 2-Meter OWA Family
Part 3: Increasing OWA Gain
vs. Preserving Sidelobe Suppression

By **L.B. Cebik, W4RNL**

In our preceding discussion, we developed tentative answers to two out of our three inquires that emerged from the extension of the OWA 2-meter family to 20 elements. By way of quick review, the low gain but high sidelobe suppression of the 20-element version of the array left us with these questions.

- 1. Which of the two OWA design concepts--the core or the method of adding new elements--has the dominant effect on side-lobe development?
- 2. Is there a method of obtaining more gain from the OWA series without sacrificing sidelobe suppression and attenuation?
- 3. What role does element population play in sidelobe attenuation?

Building a CCD Antenna

By Joel C. Hungerford, KB1EGI

This month, I continue looking at a thing I recently heard about on the [antenna discussion list](#) — a so-called CCD antenna. CCD stands for “Controlled Current Distribution.” It consists of a string of series tuned circuits and short bits of wire between them. The circuits are all tuned to the lowest frequency to be used. The current at each circuit can be set by the reactance of the inductor and capacitor. It seems a natural for the combination of the interlaced wire capacitor I used to tune the loop, and small coils, all wound on a long PVC pipe. What if one used a modest number of tuned sections, say 5 to 10, and increased the reactance as one progressed from the feed to the end of the pipe, following an approximate tangent curve. Could this simulate the current in a vertical, but in a shorter distance? Would it radiate? Just how does the tuning behave if I string together several sections all tuned to the same frequency, but with a different L/C ratio in each section?

So, this month I set out to build a CCD antenna, consisting of several series tuned circuits all resonant at the same frequency, but with each section L/C ratio varying along the antenna to mimic the effective impedance of a dipole: high impedance at the open end, and low impedance at the center.

Yagi-Uda 2-Meter 12-Element Beam Design

By Fred M. Griffiee, N4FG (EE Retired)

In this article, a 2-meter 12-element Yagi antenna will be designed using optimization in lieu of the Optimized Wideband Antenna (OWA) approach (Ref 1, 2, 3). The optimization approach I shall use follows the conjugate-gradient optimizer type found in many programs such as YO by K6STI. However, the more interesting approach may be the generic optimization approach, but to date I find it to be overly lengthy, cryptic, very time consuming, and difficult to implement. I find the conjugate-gradient approach creates designs through its progression that follows user defined gain, SWR, impedance, F/R ratio weighting, and element characteristics (diameter, wall thickness, material, etc..). Any of the mentioned characteristics can be altered where the azimuth coverage is assigned with respect to 180 degrees (N – 180 degrees). The DL6WU-gg program, for example, creates side lobes that start at 45 and 315 degree E-plane azimuth so the range will be assigned 45-180 degrees.

THE BILOOP – A LOOP TUNABLE WITHOUT THE USE OF CAPACITORS

By Claudio Re, I1RFQ

Recently, on the *antenneX* [antenna discussion list](#), several contributors expressed interest in learning more about improving the performance of compact loops. This was prompted, in part, by the introduction of some new antenna concepts based on recent articles on the “Cubes Family.”

The most common question seemed to be, “What techniques are available to significantly improve the performance of compact loops?” Over the last few years, the author has spent quite a lot of time reviewing this subject from the point of view of the amateur radio operator. This article contains some of the results of these studies.

THE GROUNDED HORIZONTAL LOOP

A single antenna from 10 to 160m
Or, the TTT: Top-Band Top-Fed Top-Cap Antenna
J.M. Bourdereau, MD, F5LCI of France

Author J.M. Bourdereau says the "horizontal loop antenna" has many advantages, when there is enough area. Grounding at a voltage node does not affect its characteristics, allows static drain, and allows its use as a top-loaded top-fed vertical for lower frequencies. This idea seems confirmed by computer modeling. Thus, we have (at least) two antennas in one.

ORTHOGONAL CURRENTS

&

TANGENTIAL MAGNETIC FIELDS

Experimental Evidence

By William Miller & Werner Hödlmayr

In the 1860's, James Clark Maxwell postulated the existence of Displacement Current as the mechanism whereby Alternating Current (AC) flows through a capacitor. It forms the keystone in a series of equations — often called Maxwell's Equations — that are the basis of all Electromagnetic theory.

About a year ago, *antenneX* published the author's 2-part article called, "Displacement Current Does Not Exist." The article was prompted by the apparent failures to perform as claimed found in two classes of antennas — the CFA (Cross Field Antenna) and the EH. The inventors of both antenna types claim that they "use" displacement current as an integral part of the radiation process.

July's issue of *antenneX* (July 2004) featured an article by William Miller entitled, "How A Capacitor Really Works." In this article, Mr. Miller postulated an alternate explanation for Maxwell's "Displacement Current." Displacement Current is the key ingredient in the equation set that relates the total Magnetic Field from an AC conductor to the magnetic field generated by current flow and electric field.

In his pursuit of working proof, Bill has recruited the very able assistance of Werner Hödlmayr, well known for his previous work on the MicroVert, TeslaVert, Fractals and others. The latest of Werner's TeslaVert versions was chosen for some experiments while applying Bill's theories. This month's joint article discusses Bill and Werner's initial experiments and the early evidence realized from them.

ARCHIVES Volume I, II, III, IV, V & VI available!

[Go Here to See List of Articles](#)

View These *FREE* Preview Articles and More!
 Plus New Monthly Columns!

See What Others Are Saying

[CLICK HERE TO SEE](#)

View These Articles Now! Come often to see content changes!

● [Antenna Modeling](#)

A Monthly Column by L.B. Cebik, W4RNL

● [From The Shack](#)

A Monthly Editorial Column

● [Ham WorkShop](#)

A Monthly "How-To" Column

● [Stone's Throw!](#)

A Monthly Column by Jack L. Stone, Publisher

● [See these FREE Previews & many more](#) ●

● [NEC-Win Synth - An Antenna Modeler's Dream Tool](#)

- [Cubical Quad Notes ~ Vol 1&2](#)
 - [The Hawks CTHA Evaluation](#)
 - [The Crossed-Field Antenna-Part I](#)
 - [15 VOLTS Up to 40 AMPS for \\$25](#)
 - [Natural ELF Whistler Radio - Part 2](#)
 - [All-Band Inverted L Antenna](#)
 - [The Screwdriver Antenna](#)
 - [The Log Periodic Dipole](#)
 - [Love My Loop!](#)
 - [W5QJR Antenna Revisited](#)
 - [Build a 2 Meter DRRR for Mobile](#)
 - [No Tuner Antenna System](#)
 - [A 3-EL Mono-Band Yagi for 20 meters](#)
 - [NEC4WIN95 Software Review](#)
 - [Economical Vertical Antennas](#)
 - [The SMITH Chart - Why Do We Need It?](#)
 - [Analysis of CFA Field Strengths](#)
 - [Microwave Absorption in Humans](#)
 - [CFA & DLA Discoveries Using PSpice](#)
 - [Mobile Operation in Outback Australia](#)
 - [Dr. Yagi & W1MDZ Dielectric Antennas](#)
 - [Starting Your First VHF Station](#)
 - [SSB "Q" Channel Communications](#)
 - [Novel Responses](#)
 - [The L-Antenna](#)
 - [Hairpin Magnetic Monopole](#)
 - [2 Meter Handheld for \\$88](#)
 - [Effects of VSWR on Transmitted Power](#)
- [Professional RF Network Designer: A Short Review](#)

SOLUTIONS

- ? need a compact antenna?
- ? have signal problems either transmitting or receiving
- ? can't choose between a vertical or horizontal antenna
- ? want to learn about antenna modeling
- ? want to design an antenna, but don't want to redo the wheel
- ? need a program for antenna design and antenna plotting
- ? don't know what antenna is best for hamsats or others
- ? have a busy mobile signal on all bands
- ? need an inexpensive directional antenna for 10 meters
- ? need a low-noise antenna for 160 meters
- ? want to know if someone else has solved your problem
- ? need a disguised mobile antenna for the vehicle
- ? just want to know more about antennas

Then you *need* to [subscribe](#) to [antenneX](#)© ONLINE! ... but take a good look at our info page [About antenneX](#) , some [preview](#) articles, and [pricing](#) pages before you decide to subscribe. Be

sure to read our monthly editorial page which is always posted outside the Library for all to see. Please visit our many [Discussion Boards](#) and talk to the Editor or others about your ideas. This board also serves as our Letters to the Editor section.

Send mail to webmaster@antennex.com with questions or comments.

Copyright © 1988-2004 All rights reserved - *antenneX*©

Last modified: July 04, 2004

THE \$4 SPECIAL

by Joe Tyburczy, W1GFH

Sure, you can find "all-band wire antennas" for sale in the back pages of Ham magazines costing \$150 or more. But beware: *Marconi spins in his grave everytime a ham buys an aerial instead of building it!* Look, the plain and simple truth is that wire antennas for the HF bands were intended to be *hand-made* and not store-bought. Untold generations of intrepid Radio Hams have fashioned their own equipment out of spit and baling wire. In this world of microprocessor controlled micro-rigs, this may be your only chance to build something and actually see it work on the air. Think about it.

Another bonus of "rolling your own" antenna is that it costs you next to nothing. Don't be intimidated by SWR, either. Your rig will not blow up and kill you. Most modern rigs will politely refuse to transmit into a really bad match. A perfect 1:1 SWR is for sissies, anyway. All **real** hams have conducted perfectly good QSO's at 3:1, and even 10:1 at some time or another. Anyhow, I recommend a tuner. This, you can buy over the counter with a clear conscience.

I am a big believer in balanced line vs. coax. The basic "W1GFH \$4 SPECIAL" shown below is a variation of the type of exceptional skyhook I've been using for years.

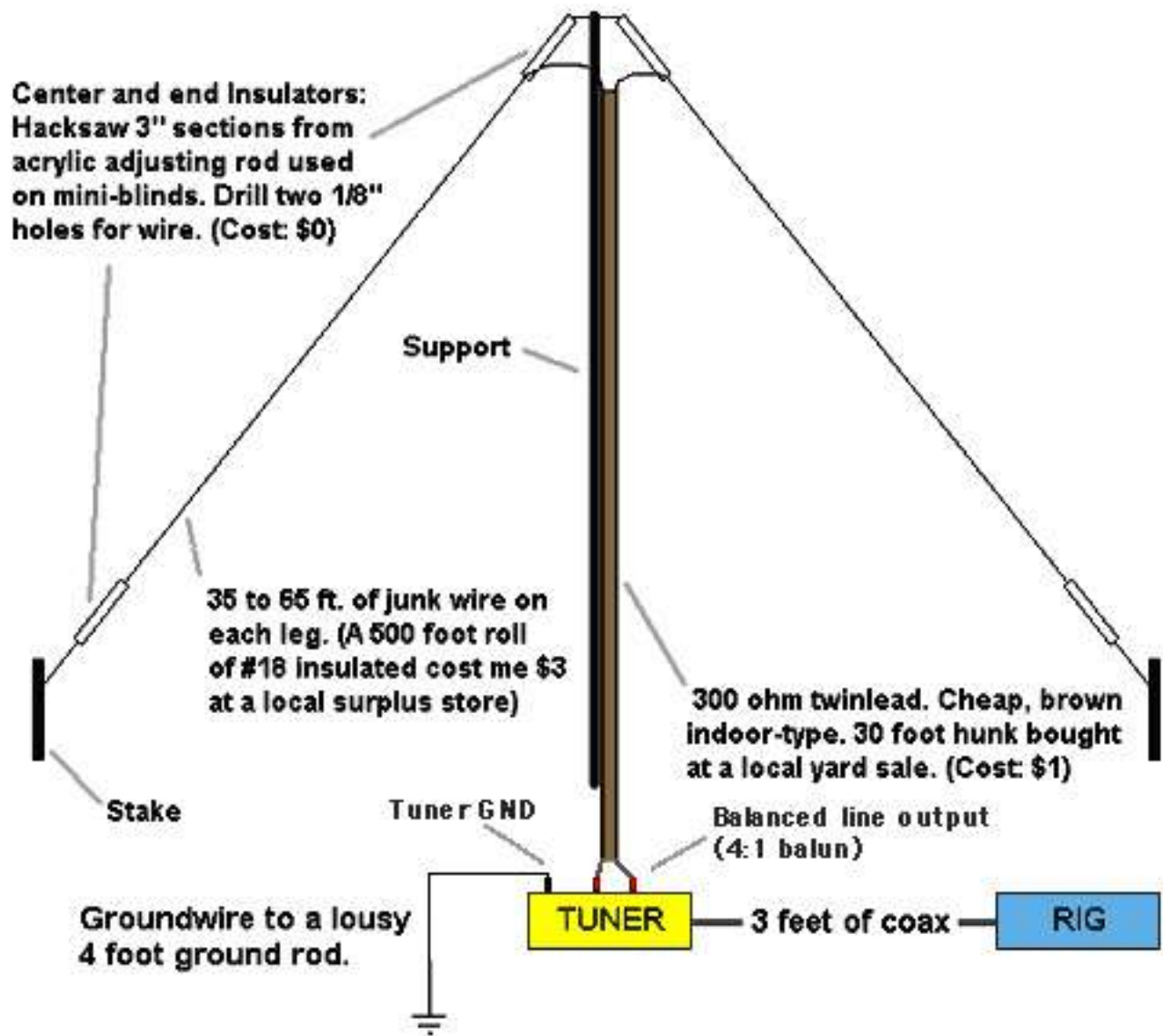

I've tried the commercial 450-ohm ladder line, but prefer 300-ohm TV twinlead, and the cheaper the better. Forget all that crap about impedance, wavelength, and velocity factor. What you really need to concentrate on is getting an interesting set of *antenna insulators*.

Back during the disco era when I first got on the air, I got a pair of really cool antique *pyrex antenna insulators* from a flea market table in Derry, NH for 25 cents each. They looked like the kind Hiram Percy Maxim used in 1910, and seemed able to pull in exotic DX all by themselves. The other day I

found out that Radio Shack wants \$5 apiece for insulators made from some kind of white plastic crap. So I improvised my own by sawing up pieces of an acrylic adjusting rod from a discarded miniblind. I think Hiram would've been proud of me.

The tuner was an MFJ-949C I got at a swap meet for \$15 a long time ago and has connections for balanced lines on the back. A link-coupled balanced tuner arrangement like the Johnson Matchbox would be better, but use what you have. The idea is to *get on the air with a decent signal for cheap*, just like they did in the early days of ham radio!

I had a 65ft. per leg version of this antenna working in Massachusetts, and it'd tune up on all bands 80-10. At my Burbank, California QTH, I used a 35 ft. per leg version, and it tuned up on 40-10. By the way, you'll notice it's an inverted vee --- a real advantage if you don't have room for a full-on dipole in your yard. If you still don't have room, bend and angle the legs to fit the space you've got. Antennas gently bent into Z-shapes still work fine!



THE *MAGIC* OF TWINLEAD

The feedline comes straight in thru a window sash. The nice thing about the 300 ohm twinlead is that the small stuff only needs about 2" separation from metal objects in its path. (OK, so TV Twinlead won't take a kilowatt, but the 450 ohm stuff you can obtain at ham stores will. You just need to be more careful with routing it)

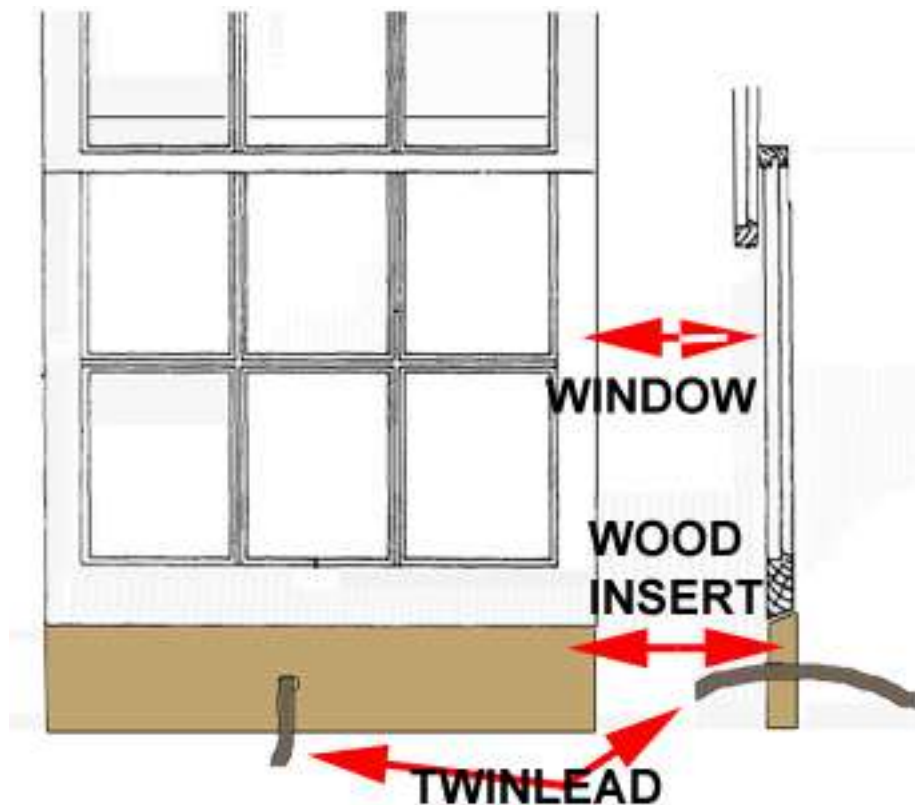

You can get a 4:1 balun to make the transition from the balanced line to a length of coax, so you can bring the coax into the house via a properly sealed-up feedthrough hole to avoid winter drafts if you'd like. If you really want to get nutty, try using 110VAC lamp cord ("zip" cord) as a feedline. Yeah, it'll work as a crude balanced line, believe it or not. Impedance varies, but is usually "close enough" to work. *Improvise. Experiment.* Take notes of what works and what doesn't. This is what ham radio is all about.

Many of you will recognize this antenna as the venerable "double zepp" aerial, a variation of the "end-fed Zepp" -- the skyhook responsible for the dramatic Hindenberg tragedy in Lakehurst, NJ. It seems the blimp's radio op decided to work a little DX while waiting for landing clearance. He sent out a few CQ's. Unknown to him, the ladder line had twisted in the breeze, shorting the bare conductors. A brilliant spark flared

up, and....well, that's another story altogether.

To see an "end-fed Zepp" version of the \$4 Special, click [here](#).

Alas, I never had the height to make this antenna perform the way it should. The one in Mass. was up 50 ft. and worked terrific DX. The one I have now is only up 30 ft. and gets average results. It won't outdo a yagi at 100 feet, but what will?

And for \$4....who can complain?!

ADDENDUM: November, 2002

Since writing this article, I've gotten a lot of questions. Many are curious about the end-fed Zepp. I suggest you go to L.Cebik's fine page on this subject for an explanation of the practicalities of such an antenna:

<http://www.cebik.com/gup/gup12.html>

The other question deals with feedline lengths. Is there any 'ideal' length? Yes and no. Some feedline lengths will

present an extremely high impedance to the tuner on certain bands. Each installation is different, but here are some rough guidelines that may help:

Start by trying a feedline listed in the lengths below. It may take some trimming or adding of feedline to work well on the range of bands you want to cover. The worst possible feedline lengths are shown in brackets:

If Ant is 120 ft per leg it will cover 160 thru 10 meters.
Feedline of 40-70 or 150- 190 feet suggested. [Avoid lines around 120 or 240 ft]

If Ant is 65 ft per leg it will cover 80 thru 10 meters.
Feedline of 25-40, 80-100 or 140-160 feet suggested. [Avoid lines around 60, 120, or 180 ft]

If Ant is 33 ft per leg it will cover 40 thru 10 meters.
Feedline of 40-50, 70-80, 100-110 or 130-140 feet suggested.
[Avoid 30, 60, 90, 120 ft]





[Start a Group](#) - [My Groups](#)

hfpack · HFpack. HF Portable Group www.hfpack.com

[[Join This Group!](#)]

[Home](#)

Members Only

- Messages
- Chat
- Files
- Photos
- Links
- Database
- Polls
- Calendar

Description

Category: [Other](#)



www.hfpack.com

Daily HFpack On-The-Air Schedule:

Global: 1630UTC and 2230UTC on 18157.5kHz USB or 18158kHz CW

Global: 0350UTC on 10117.5kHz CW

Saturday/Sunday HFpack On-The-Air Schedule:

North America: 0145UTC on 5371.5kHz USB or 3996.0kHz USB

Europe: 1840UTC on 7087.5kHz LSB

Australia/Asia/Oceania: 0915UTC on 3587.5kHz LSB

Other HFpack Calling Frequencies: 7240USB, 14342.5USB, 21437.5USB, 28327.5USB

The complete HFpack Frequency Chart is on the WWW.HFPACK.COM website.

High Frequency Portable transceivers and antennas. HF SSB/CW/Data. Amateur commercial marine. Handhelds backpacks carry-ons manpacks. Pedestrian and Human Powered Mobiles. Manual and automatic antenna tuning. Telescopic tape folding and collapsible antennas, dipole, broadband hf vertical antennas. Battery solar crank alternative energy power supplies. Compact lightweight miniature equipment. Handsets headsets microphones earphones keyers. Low power TX/RX techniques. Portable amplifiers. Hiking camping bicycling kayaking and expeditions.

HFpack egroup messages are intended as private communications between the members of HFpack only.

"FOR SALE" NOTICE POLICY:

Equipment For Sale must be HF Portable

and include "Reply Direct Only" in the subject line.

HFpack File and Image Uploading Now Using HFpack2: <http://groups.yahoo.com/group/hfpack2>

Group Info

Members: **4625**

Founded: **Nov 15, 2000**

Language: **English**

Group Settings

- Not listed in directory
- Restricted membership
- All messages require approval
- All members may post
- Archives for members only
- Email attachments are not permitted

What's New

New within the last seven days:

Messages: **56**

Message History

| | Jan | Feb | Mar | Apr | May | Jun | Jul | Aug | Sep | Oct | Nov | Dec |
|------|-----|-----|-----|-----|-----|-----|-----|-----|-----|-----|-----|-----|
| 2004 | 380 | 424 | 485 | 392 | 444 | 439 | 409 | 392 | 50 | | | |
| 2003 | | | | 501 | 647 | 486 | 350 | 263 | 234 | 280 | 375 | 445 |

Group Email Addresses

For more information: <http://www.hfpack.com>

Post message: hfpack@yahoogroups.com

Subscribe: hfpack-subscribe@yahoogroups.com

Unsubscribe: hfpack-unsubscribe@yahoogroups.com

List owner: hfpack-owner@yahoogroups.com

Yahoo! Sponsored Links

[Computer Science Degree Online](#): Earn a MS in Systems Management online from Florida Tech without the inconvenience or distractions of on-campus programs. Prepare for the high-tech business world of tomorrow - today.

forms.universityalliance.com

[NTU - Online Computer Science Degree](#): NTU delivers outstanding programs for engineering and IT professionals. Whether you are looking to get your Master's degree, or a refresher course, NTU offers the program you need.

www.ntu.edu

[Looking for Computer Science Programs?](#): Search our complete directory of U.S. computer science schools. Get admissions information from featured programs.

www.allengineeringschools.com

Copyright © 2004 Yahoo! Inc. All rights reserved.

[Privacy Policy](#) - [Copyright Policy](#) - [Terms of Service](#) - [Guidelines](#) - [Help](#)

Welcome to G4VGO's Kite and Balloon Antenna Site

Featuring Limited Space Solutions for the Low Bands

Some of the Top Band Antenna Information You Will Find Here:

[Page Two, My Kite and Balloon Lifted Antennas](#)

[Page Three, All About 'Aerial' Antennas](#)

[Page Four, Kites as Lifters, The Background](#)

[Page Five, Balloon Lifted Antennas and General Flight Safety Issues](#)

[Page Six, Winches and Rigging for Kite and Balloon Antennas](#)

[Page Seven, The Full Wave 160 Delta Loop...It Worked Well.](#)

[Page Eight, Miscellaneous Aerial Antenna Information](#)

For now, the QTH is Singapore.

The call is **9V1GO.**

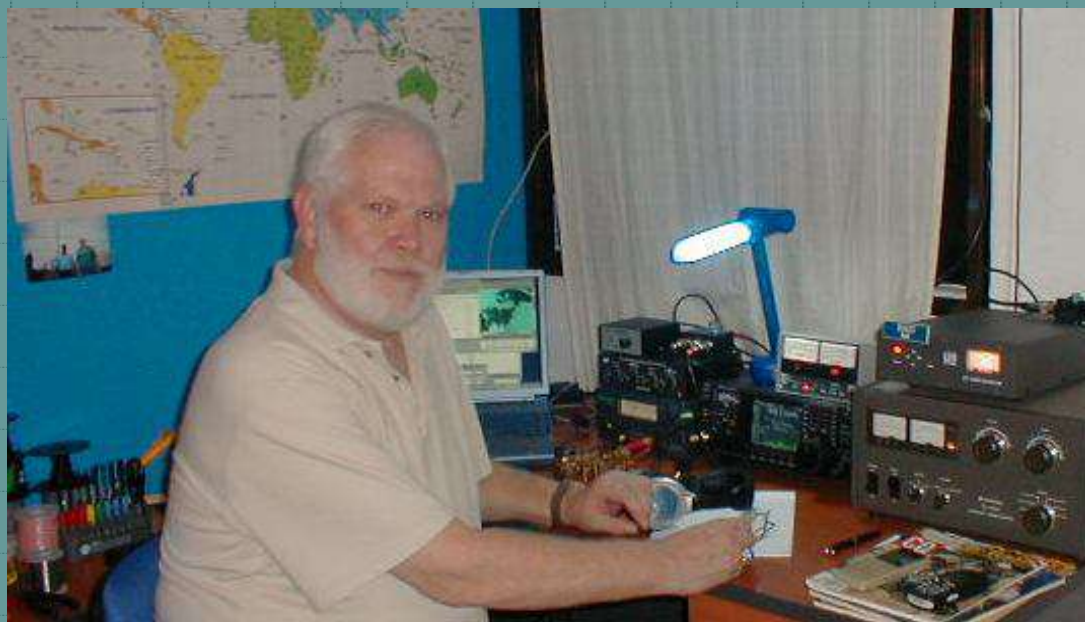

My name is Bob, and I have been an amateur radio operator since 1962. My activity on Top Band goes back 20 years.

Now, I am living and working in Singapore. This past season (2003-2004) 91 DXCC entities and 30 zones were worked on Top Band. Now there are 92 DXCC countries in the 9V log,

thanks 4X4DK. Conditions have been getting better the past few weeks, and it is nice to know that the new season is not too far away.

If you think you have worked me from **9V1GO**, you can check the log at <http://dx.qsl.net/logs/index.html> and look under my call for the logs from here.

The 160 metre transmit antenna is a half sloper at 40 metres. I have one receive antenna that has out performed pennants and flags. It is a full sized half wave dipole two metres off of the roof of the 13 floor apartment building. I also have a tuned co-ax loop that occasionally out performs both the low RX dipole and the TX sloper, depending on conditions. Watch for Top Band activity from Singapore on 1814.5 and 1822.0 at my sunrise and sunset. In addition, CW on 80, 40, and 30 metres will get a lot of attention as the S9 QRN on 160m in Singapore is hard. Up to more than 100 DXCC on all the rest of the bands but 10 and 12 metres. Email me for a sked if you need 9V on any of the low bands. **Please QSL DIRECT ONLY to my manager OK1DOT - Petr.** His address is on the QRZ.COM web page.

Now, for a little about G4VGO at home:

In "G" land, Top Band is my O-N-L-Y band, and I have been active in Europe since 1984 on 160 meters. Shortly after coming to the UK in 1980 I was issued the reciprocal call G5EPD. A few years later it was changed to **G4VGO**. That has been my call in the UK since then. In 1985, I managed to confirm 102 countries and received 160 Meter DXCC Certificate #269. Since then the total has increased to 224 with 39 zones. The entire country total has been on CW.

I am now fortunate enough to live on a piece of land with wide-open space (when I get home). The farm is in the middle of countryside, not far from the North Sea coast and with more than enough room for beverages, and tall masts. Although the necessity for kite and balloon lifted antennas is not so acute with space in every direction and no neighbours to worry about, I still really enjoy putting the wire high up in the air. The chances of increasing your score in a Top Band contest or pushing the country total higher go up by about the square of the height of the antenna on 160.

My job is a telecommunications consultant and I work mainly with mobile networks. This profession has taken me all over the world. I have deployed networks on all continents but Antarctica and came close to there when we put a site in very southern Argentina. It is fortunate that my hobby and my work both involve radio and I enjoy both very much.

In 1997, I was **E17IU** in Naas in county Kildare, just outside of Dublin. In seven months I managed to work more than a hundred countries on Top Band including Myanmar and a few other rare ones with 150 watts and a 14 metre 'T' antenna.

For about eight months in 1999 I was **LU/KY0C** in Buenos Aires while working there. Conditions were terrible in the noisy city environment, but regular QSO's with W8JI and other USA big guns were the norm. It was good to get back to the UK, to low noise and better propagation.

In 2001 I spent five months in Israel as **4X/G4VGO** and with 25 watts to a full sized 160 metre sloper and two Pennant receive antennas managed to work more than fifty countries including the USA and Canada. Again, Israel was a very noisy location with poor summertime propagation.

I left **SM Land (SM0/G4VGO)** after about six months there in the last half of 2002. While staying in Kista near Stockholm I worked 42 countries with a marginal antenna and very low power. I didn't have such good antenna possibilities, but as the nights got longer, DX picked up a bit.

The Home Shack



This is the home QTH operating position. I have tried every top end transceiver in the world, and for several years used FT1000Ds as the mainstay. For a while, I used an FT1000MP, but went back to the 1000D. I also bought an ICOM IC746Pro to try, and after exhaustive trials on Top Band, sold one of my FT1000D's and opted for the 746Pro. It was a good transceiver, but then I had a chance to try the Ten Tec Omni VI. After a few nights on 160m CW, I decided I should have gone with the Omni VI years ago....it is AWESOME on CW receive. For CW, I use the Omni VI, but for SSB, the D104 and the TS830S are a very good combination. The old Kenwood has done well in many SSB contests on Top Band.

My latest purchase here in Singapore was a Elecraft K2/100. With the latest firmware and keying mod it is rapidly becoming a contender for my main radio. (Although the Icom 756 Pro II I am also using does have a pretty good receiver on the low bands. However there are no

strong signals nearby to contend with at my 9V QTH) European Top Band activity is a challenge for any receiver, so the K2 may be the new rig of choice upon the return to G4VGO.

The Dreaded Key Clicks

Most stations I hear on CW have key clicks. After participating in many contests on CW and suffering the clicks, I decided to get rid of all of my Yaesu radios and change to the Omni VI and the trusty old Kenwood TS830S. The TS830S has **NO clicks** or phase noise, and the RF speech processing in the 830 makes it one of the best rigs for that mode ever made. The Omni VI has had the key click mod, so it is a lot better than anything I have used in the recent past. All of the transceivers I am using now do NOT cause the obnoxious and very broad key clicks that the Yaesu FT1000 series (**ALL of the FT1000 series**) cause. In a pile up, the unmodified Yaesu rigs sound like a convention of castanets clicking up and down the band several tens of KHz. Really rotten keying. Add several tens of dB of phase noise and you have a proper mess on Top Band.

There is an excellent "must read" article by Tom W8JI on CW Key Click's (Spurious Emissions) caused by Yaesu Top-of-The-Line FT-1000 Series HF Rigs. This includes, the FT-1000MP, the Mk 5, the MK 5 Field and FT-1000D Models. The receivers may be mostly OK, but the CW transmitters are **CRAP!!!!!!** I see more and more of the FT1000 variants for sale used now so maybe someone is listening. Or, maybe they are tired of hearing complaints about their terrible keying from those they clobber with the clicks. Anyway, it is clear that Yaesu has "zero" concern about good engineering practices, customer service, quality control and spectrum management. We should all think twice before buying one. Can Yaesu say "Lost Revenue Stream"? The new Icom radios have variable keying rise times, as does the new Ten Tec Orion, why can't Yaesu make a good CW transmitter?

I use Beverage and Pennant antennas for receive. An east Beverage on Asia and the Pacific one and a half wavelengths long on 160.... a pair of phased end-fire Beverages to the northwest on North America, one and a half wavelengths long and a south Beverage one wavelength long take care of the main DX directions. The Pennant receive antennas look southeast and northeast as 'gap fillers' on Africa and deep Asia. Beverages and Pennants at this quiet location have given me a whole new level of weak signal capability that I had forgotten existed. They also give me a front to back ratio that gets rid of the European key clicks that can drive you nuts.



special antennas

Antennas

Probably the best DX site in the world

DX news



Balloon or kite antenna? Why not

First thick nylon line, then copper wire
 Be extremely careful about static
 My balloon and kite antenna system
 Kite antenna - watch out!
 Balloon antennas - a theoretical approach
 Excellent supports for LF antennas

First thick nylon line, then copper wire

From: Hugo Caron (hugo@infobahnos.com)

Date: Nov 4, 1996

Original source: Usenet's rec.radio.shortwave

Last month there was a discussion about balloon antennas, mainly about using 2 balloons instead of one for a vertical antenna. Two persons mentioned their concerns after having read articles on the subject relating about wind-induced static shock hazard and reception high noise level.

One participant replied that if one would shunt the antenna with carbon resistor (~4.7k-22k) to local ground, high enough not to upset antenna characteristics but still, low enough to discharge the beginning of charge buildup, one would be able to cope with this problem.

On the same subject, a second participant with actual balloon and kite antenna experience (300 ft - 100 meter) did report the reality of shock hazard, but eventually got around the problem by shunting an antenna tuner inductor to ground or shunting the antenna directly with a 100k resistor. He reported that in these conditions, he was able to get signals that sounded great. Also in light wind conditions, he said that static was not much of a problem.

On the structural aspect, for security reasons, personally I wouldn't try to tie a thin copper wire directly to the balloon, as some may have suggested. I'd rather use high strength nylon or alike line (fishing line type for exp., I've seen some with 40 lbs capacity) to carry the all strain the holding line may be subject to in presence of higher winds than expected. The thin wire copper line would only be 'brought along' for its antenna role. To avoid any wobbling of the 2 lines, I would knot, using short length of holding wire (trimmed after knotting), every 5 feet or so. For example, if one want to jack a 300 feet vertical up and chooses a

- [▶ Front page](#)
- [▶ DX News](#)
- [▶ Logs](#)
- [▶ Andes DX](#)
- [▶ Antennas](#)
- [▶ DX Lab](#)
- [▶ In Print](#)
- [▶ Web Stories](#)

Archives

- [▶ Web Archive](#)
- [▶ Mail Archive](#)

Search

- [▶ Search all HCDX](#)
- [▶ mail since 1995](#)

About us

- [▶ About us](#)
- [▶ Write to us](#)
- [▶ Copyrights](#)
- [▶ FAQ](#)
- [▶ HCDX mail list](#)

nylon line of 20 lb capacity (lets say it's 2000 feet/lb (.0005 lb/foot) and AWG #28 copper wire at 2081 feet/lb (again, ~.0005 lb/foot) and 65 ohms/1000 feet (ARRL handbook), one would end up with a line at .001 lb/foot for a total payload of .3 lb. So the balloon would need, at least, this 'net' boyancy (preferably a bit more let say .4 lb). By net boyancy I mean the payload the balloon can handle, after lifting its own weight. A 3.5 to 4 feet diameter ballon should be able to handle this charge, depending on its envelope weight.

The balloon envelope material quality his also something one should consider before attempting any lift off. If not, one may experience a short lived project.

We've all air blew party rubber balloons to their max, just to realize that the next day they had shrunked to half their size. The reason being that, due to pressure differential between inside and outside of the streched envelope, air will just sift through it. Rubber is an elastomeric material build around long organic molecular chain attatched one to the other through ramifications (something like a tree), and there are 'holes' between these chain elements. Air (that is, molecular oxygen, nitrogen (and carbon dioxide if you blew the balloons yourself... pfiew!!)) eventually finds its way through. So if molecular elements like O2 and N2, that are many time the size of atomic helium (He) can do that, you can imagine how helium would act considering the wide open barn doors these 'holes' are, relative to its size. I dont think one would be able to retain it for more than a couple of hours. So not any off the shelf stock will suffice.

I've done a few phone calls, a couple of weeks ago to see what's available, mentioning I was looking for a balloon to be inflated with helium, that was able to retain its content for at least a couple of days. The only source I found was the Party Decoration retailers. I eventually found someone that told me they had 42 inches size balloons, the envelope of wich is made of unstretchable material (vynil???) made for that purpose (helium inflating) for \$5. They would inflate them for \$5 each. One can also get pressured helium portable refill thanks, good for ~25(?) of these balloons, at \$60. They were not able to specify the envelope weight or the ' net boyancy '.

Another retailer told me the he could supply me with a 7 feet balloon (that's 9 times the volume of 42" diam.), again the unstretchable kind used for outside advertizing, hence relativity long lasting, with a 4 lb lifting capacity for CAN\$342 + helium...

Ooops, this time *my* budget was blown!

Be extremely careful about static

From: Jake Brodsky frussle@erols.com

Date: Nov 6, 1996

Original source: Usenet's rec.radio.shortwave

First: Hugh Caron's post concerning static charges on the balloon wire are accurate. I was one of the guys he spoke about and, yes, when flying kites with a wire antenna, one must be extremely careful to bleed off the static charge. My friend Tony, was practically thrown across the deck of his boat when he touched the ungrounded wire on one of our kite- antenna experiments.

Two: Helium is much easier to buy and transport than hydrogen. It may not be cheaper, but at least you don't get anything close to the HAZMAT paperwork you'd get if it were hydrogen.

Three: Although latex balloons do deflate more readily than, say, mylar balloons, the surface area to size ratio of an eight foot weather balloon will guarantee that it will stay up for quite a while.

Four: The FAA's relevant regulation on this subject of tethered kites and balloons is Part 105. When I last read it three years ago, it said that anything with a total weight of under five pounds empty is exempt from most regulations.

You do have to know where the airports are, and don't fly your kite or balloon where it may get in the way. A call to the local Flight Standards District Office (in the United States) will go a long way toward clarifying whether the place and altitudes you wish to fly the antenna are appropriate. Even if you might fly it so high that it could interfere, they'd be more than willing to accomodate you by issuing a NOTAM, or NOtice To AirMen, with adequate notice, and then issue you a permit for a certain time and place.

My balloon and kite antenna system

From: Jake Brodsky frussle@erols.com

Date: Nov 7, 1996

Original source: Usenet's rec.radio.shortwave

Since the discussion is going this way I'll go in to more detail as to how I handled the Balloon and Kite antenna systems.

First, all flights were made from a boat, a few miles south of the Middle River in the Chesapeake Bay. All lines were 400' or less.

The kites and balloons all had empty weights of under five pounds (thus not requiring notification under part 105). Prior to conducting these tests, I contacted the Baltimore Flight Standards District Office for advice on how to proceed.

We thought briefly about using a strobe light. The problem was two fold: first, the strobe itself sometimes put us over the part 105 weight limit (depending on which kite we used). Second, the strobe light could easily have been mistaken for a life-vest strobe light on the water

(because that's what it was). We decided to keep the line to about 200' instead, and to forget the strobe light.

There are few standards for this sort of activity. Kites and tethered balloons are usually not a problem for most aircraft, especially those over open water. I caution you, however, to know the area where the airports are, to know where the instrument approaches are and to avoid those places. This is something I'm already aware of, since I am an instrument rated pilot.

In any case, low flying aircraft don't often go over open water, so the risk of collision is low (the big sky, small target theory). Obviously, these details are things you should consider well before purchasing that kite or balloon...

Kite antenna - watch out!

From: Glen Leinweber leinwebe@mcmail.cis.mcmaster.ca

Date: Dec 12, 1994

Original source: Usenet's rec.radio.shortwave

Using a kite, or balloon, to launch a long-wire antenna is a risky business, even on a clear day with no clouds around. The danger arises from the electric field between the earth and ionosphere. This field is about one hundred volts per meter (in the vertical direction), and is always present. Any antenna launched into the clear blue yonder will acquire a charge large enough to wipe out a final transistor, or a receiver front end.

So what's the difference between ordinary outdoor antennas and one attached to a kite?

Earth's electric field is easily distorted by objects attached to ground, like a tree, or mast, or house (your tower doesn't have a few kilovolts between top and bottom). A kite-borne antenna protrudes into wide open spaces, where it very likely gets charged up. Your earth-bound antenna is attached to a mast or tree or house, where earth's electric field is greatly reduced.

Here are some precautions for kite experimenters, or anyone who uses temporary outdoor antennas:

Add a choke coil to the antenna connector between centre pin and ground. This will leak away any charge that tries to accumulate. I see that most modern rigs don't provide a D.C. discharge path from antenna connector to ground - this is dangerous to your equipment.

This choke won't save you if you connect a charged antenna to your rig after you've put it up: either discharge the antenna to ground or connect

the rig to antenna **before** putting it up.

A few years ago I put up a two-meter 1/4 wave antenna on top of my tower. The coax snaked thru the window had no connector. When it started snowing, I noticed a snapping sound every twenty seconds or so. The end of the coax was arcing over from the charge accumulating in the coax capacitance. That cable was being charged five or ten kilovolts in only twenty seconds!

Balloon antennas - a theoretical approach

From: Hugo Caron (hugo@infobahnos.com)

Date: Oct 27, 1996

Original source: Usenet's rec.radio.shortwave

The discussion about the possibility of erecting a balloon supported long vertical and/or inverted L type thin wire antennas has raised concerns about potential shock hazards and high noise levels resulting from wind-induced static. Solution replies were proposed, through the use of bleading resistor (and/or inductor) to a good ground, high enough to discharge the static buildup at adequate rate while preserving electrical characteristics of the antenna. $r > 4700$ ohms. inductor = ?

Concern was also raised about the trouble of putting up a 2 balloon setup over a single one as high (or even higher) vertical, on the base that inverted L would behave as top loaded vertical, which is omnidirectional by nature. On this, I replied it *may* and *would* only be worth the trouble *if*, considering the multiple wavelength in height and length for a large part of the SW band, such a setup would show *directivity* characteristics that would approach that of a long wire. As I couldn't answer this question myself, I left it open for comment. If there were any, I have not seen them, yet.

Lastly, concerns were also expressed about the physical (structural) 'reality' and security of such a setup. To this I brought the idea it should take the shape of a trapezoidal figure (as seen from the side). I also stated that I will try to determine through mathematical (mechanical) equations, proper sizing of such a setup along with constrains the wiring would be submit under different wind loads.

This is what will now follow.

Sizing for still-air conditions

Material specification.

Thin copper wire: AWG 28 : 2081f/lb (.0005 lb/f); 65.31ohm/1000' (source ARRL Hbk.) about \$12 for a 1500 feet spool at Mouser Electronics

Support wire: fishing line type 20+ lb at .0005 lb/f (conservative estimate).

I chose to evaluate a 200'H x 200'L feet trapezoidal setup, ABCD c.c.w. with base angle at A and D = 60 deg.

XY locations

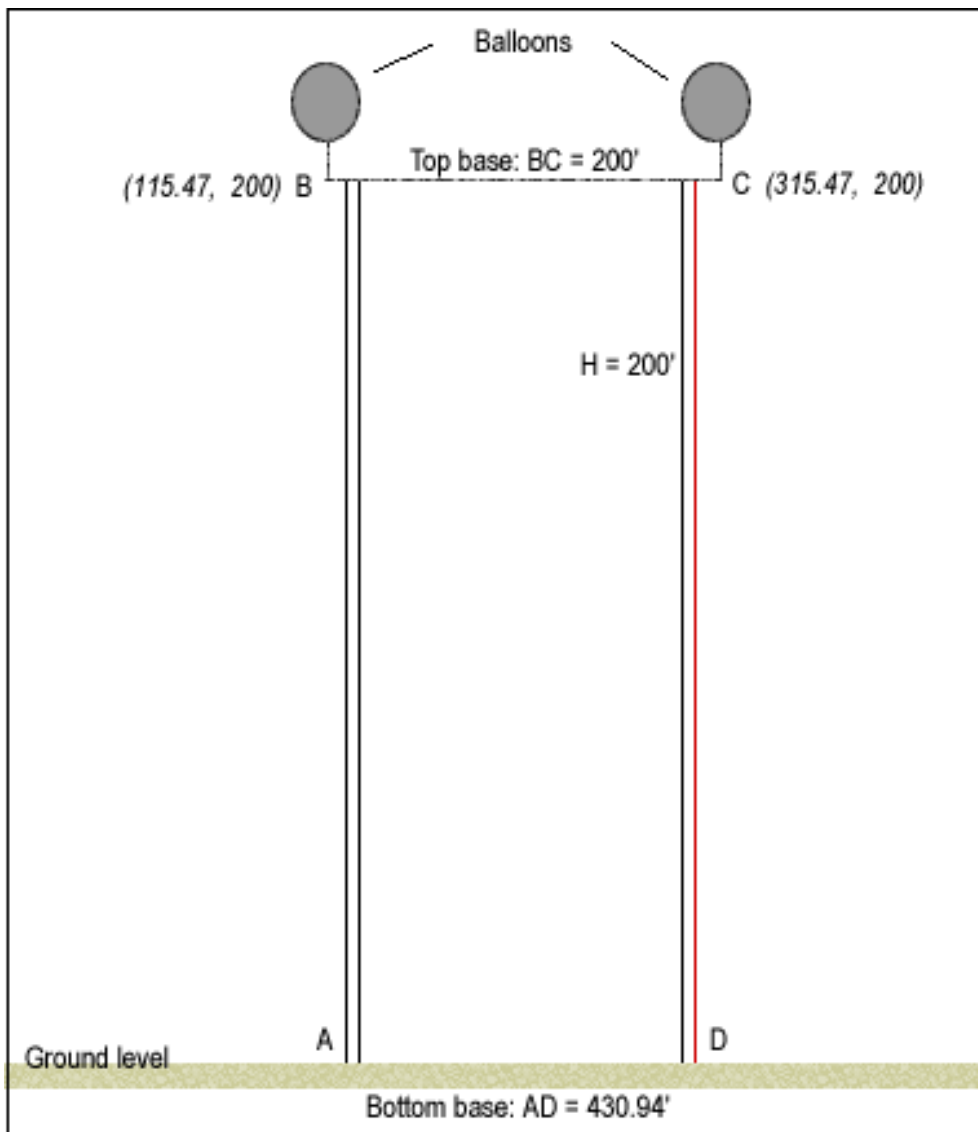

Sides: $AB = CD = 230.94'$

Top base: $BC = 200'$

Bottom base: $AD = 430.94'$ Actual side **line AB** is made of 2 lines of support cable, thus 40 lb strain capacity and unit length weight of .001 lb. Reasons for doubling this length will be brought later.

Lines BC and CD are made of 1 support line and 1 thin copper wire for, again, a unit length weight of .001 lb, and strain capacity of 20 lb (only the support wire will bear any constrain, the copper wire only brought along on support wire, for it's antenna function. So only the support wire would be attached to the ground and the balloons.

A cable or wire suspended between two horizontal points, such as points

B and C in the above figure is called a 'Catenary' in a Mathematical and Mechanical sense. A cable or wire such the ones that links A and B or C and D (sides) is more simply call a 'Flexible Cable Suspended from Two Different Levels', at least in the Mechanical engineering texbook I refered. (1952 ed., but the logic still good, even after iron curtain fall ;-))

I will limit here the results resolution of the proposed equations brought, in the case of this problem. I would suggest to those interested by the details of these equations to refer to similar book as mentioned above. They are long, dry and require the use of minimal graphic support, beyond the limit of this media, to have any meaningfull sense. I will just mention they are of the recursive type, that one can resolve with a spreadsheet such as Excel with relative ease.

The resulting figures were found to be:

Top section BC (Catenary):

| | |
|----------------------------|--|
| Actual wire lenght: | 202.97' |
| Sag | 15.0' |
| Tension at B and C | .3508 lb at 16.82 deg with horizontal axe |
| | .3358 lb along x axis |
| | .1015 lb along y axis (down) |

Side sections AB and CD

| | |
|----------------------------|--|
| Actual wire lenght: | 231.22' <i>(to compare with 230.94' above, thus very little sag on those)</i> |
| Tension at B and C | .7790 lb at 64.47 deg with horizontal axis |
| | .3358 lb along x axis |
| | .7030 along y axis (down) |
| Tension at A and D | .5790 lb at 54.55 deg with horizontal axis |
| | .3358 lb along x axis |
| | .4717 along y axis (up) |

At B and C vertical down force combine .1015 + .7030 to give .8045 lb which is the vertical upward force (net boyancy) that is required by the balloons, at each site, to maintain the setup aloft at desired location.

The Baloons

As per Archimede's principle, the upward force developed by a balloon is related to the weight of the displaced air by the balloon volume.

Actually the balloons shall be sized to carry this net boyancy (.8045lb) + the weight of the helium (s.g. = .1308 that of air) it carries + the weight of the balloon envelope.

For exp., someone wants, on 500' ASL (at sea level) site put a 200' high (= 700' ASL) balloon able to procure sufficient lift for a .8045 lb payload.

Let suppose that a 40 inches (3.33') diameter of .5 lb envelope weights is available.

Density of air at 500' ASL = .0754 lb/pi3, at 700 ASL = .0750 lb/pi3

Volume = $.5236 \times d^3 = 19.39 \text{ pi}^3$

At 700' ASL ; Weight of air = $19.39 \times .0750 = 1.454 \text{ lb}$

At 500' ASL ; Weight of helium = $19.39 \times .0754 \times .1308 = .191 \text{ lb}$

Net boyancy at 700' ASL = $1.454 - .191 - .4 = .863 \text{ lb}$

In this case, 2 of these balloons would be ok for the proposed setup. The top part would be a bit flatter (but, not by much) than calculated

Effects of the wind

In fluid mechanics textbooks, one can find formulas to determine the drag force applied by moving air upon stationary spherical object. (the balloons) :

$$F_d = C_d \rho V^2 A / 2$$

F_d : drag force (lb) C_d : drag coefficient (no dimension)

V^2 : Velocity of the wind squared (f2/sec2)

A : Center area of the sphere (f2)

$C_d = .4$ for Re (Reynold number) < 350,000

$C_d = .2$ for $Re > 350,000$

$$Re = D V / \nu$$

D diametre of the spere (feet)

V Speed of the wind (feet/sec)

ν (nu) Kinematic viscosity of air = $\sim .00016$ (f2/sec)

Below a table that shows the evolution of horizontal pressure (in ponds) induced by various wind velocities (mph) on various balloon diameter

(feet)

Table 1.
Horizontal wind-induced pressures on a spherical balloon: Fd (pounds)

| V (mph) | 3' | 3.33' | 4' | 5' | 6' | Diam |
|---------|------|-------|------|------|------|------|
| 10 | .71 | .88 | .66 | 1.02 | 1.5 | |
| 15 | .83 | 1.03 | 1.5 | 10.7 | 15.4 | |
| 20 | 1.5 | 1.83 | 2.63 | 4.1 | 5.9 | |
| 30 | 3.33 | 4.1 | 5.9 | 9.2 | 13.3 | |
| 40 | 5.9 | 7.3 | 10.5 | 16.5 | 23.7 | |

Here, I will limit the analysis to a worst case senario, where I will use only common sense to evaluate resulting strain on support wire AB. Examining the trapezoidal shape of the proposed setup, one can observe that a wind blowing from the left would induce the highest strain on line AB, resulting from the combine effect of the pressure on balloon C 'added' to the one on balloon B through wire BC.

To get these 'exact' values one would have to develop some kind of program that would require to first compute the relative reposi- tioning of each balloon wit varying wind condition and then apply vector computation to get this value. Developping such a program would be time consuming.

Common sense evaluation should suffice to get acceptable ballpark values. One can see that wind blowing from the left will tend 'push' balloon B along a circonference of radius AB, thus going down. At the same time, balloon C would be ' forced ' to travel up along the circonference of radius DC. Those 2 opposite forces would tend to oppose, resulting in reduced displacement of point B as to compare to a single vertical balloon. In any case one can see that balloon B moves at all, the effect will be to reduce the angle at A.

Hence, If one directly adds the horizontal wind induced pressure on B and C balloons (or doubles the value at B) and divide the result by cosine 60 deg, one would get a value of the strain induced in wire AB higher than reality, but still representative for evaluation purpose. I did that to Table 1 above to generate Table 2 below. Let's keep in mind these values are somewhat on the overestimated side.

Table 2.
Estimated side wind-induced strain on wire AB: T (pounds)

| V (mph) | 3' | 3.33' | 4' | 5' | 6' | Diam |
|---------|------|-------|------|------|------|-----------|
| 10 | 3.9 | 4.1 | 3.1 | 4.7 | 6.9 | Safe zone |
| 15 | 3.9 | 4.8 | 7.0 | 10.7 | 15.4 | |
| 20 | 7.0 | 8.5 | 12.2 | 19.0 | 27.4 | |
| 30 | 15.4 | 19.0 | 27.4 | 42.7 | 61.8 | Risk zone |
| 40 | 27.4 | 33.9 | 48.8 | 76.7 | 110. | |

One last table (some useful physical properties of air)

| Altitude(ASL) | Air pressure | Air density | Air viscosity |
|---------------|--------------|-------------|---------------|
| feet | lb/f2 | lb/f3 | f2/sec |
| 0 | 2116.2 | .0765 | .000156 |
| 1000 | 2040.9 | .0743 | .000162 |
| 2000 | 1967.7 | .0720 | .000164 |

Well those are my findings. I hope those infos will be of some help for anyone who would like to tackle (or proceed) with the idea of erecting some kind of balloon antenna.

A Skyhook for the '90s

By: Don Daso, K4ZA

Date: May, 1997

Original source: QST May 97, pp. 31-33

Balloons, shaped like small blimps, are in relatively common use for advertising purposes. Such a blimp, of 10- to 12-foot (3.3 to 3.7 m.) length and 3- to 4-foot (0.9 to 1.2 m.) diameter can easily be used to support a vertical antenna for temporary use, such as in Field Days. K4ZA has successfully used them, and in this article, offers the benefit of his experiences for others who might want to follow his example.

A balloon of such size, when filled with helium, will provide a lift of about two pounds, ample for a quarter-wavelength wire on the 160-meter band. The balloon should be tethered in the center of an open space of such size that the perimeter is at least as far in all directions from the tether as the length of the antenna. For safety and good results, one should select an area of relatively flat ground with no buildings, towers, trees, fences, or overhead wires within it.

The balloons are commonly made of polyurethane film of 2- or 3-mil (50- to 75-micron) thickness. The film is relatively strong but must be

protected from puncture. The author suggests laying a 20- by 20-foot (6- by 6-m.) tarpaulin around the tether where the blimp will be inflated, to protect it from twigs or sharp weeds.

The tethering line should be 100-pound test fishing line or 1/8-inch (3-mm.) nylon rope. Stranded wire or aluminum welding wire is light and amply strong for the radiator. A good quality ball-bearing swivel should be used to attach the tether to the balloon's halter, since the wind will cause it to turn, pitch, and roll in all directions. Gloves should always be worn when the blimp is being launched and retrieved. In all cases, one should avoid dangerous situations, such as operating near power lines, in wet or stormy weather, or near airports or areas congested with people. Do not attempt to use heights greater than a simple quarter-wave monopole. Finally, remember that an adequate ground system is at least as important as the antenna; use either four elevated, or up to 60 ground radials for best results.

Two suppliers of these inflatable blimps are:

Toy-Tex Novelty Company, 7315 N. Linder, Skokie, IL 60077, tel (847) 673-6600;

The Blimp Works, 156 Barnes Airship Drive, Statesville, NC 28677, tel (704) 876-6705; web <http://www.msmall.com/blimp>.

072799



**Homebrew Projects, Antenna, RF, Amplifier, Digital Techniques,
Contest with photos, projects, download...**



by **Talino Tribuzio**



Copyright 2000-2003 Talino Tribuzio - IZ7ATH Last Update Jan. 2003



Shortened 160 meter vertical



Here is a description of shortened 160 meter vertical. The Battle Creek Special is worked out [here](#).

[PI4CC home](#)

This is a copy from an article in QST December 1974.

[BCS](#)

[MK II](#)

[Additional info from K8GG on the BCS.](#)

Mobile operators and those who reside on property of city-lot size should find the author's treatment of physically shortened 160-meter vertical antennas of considerable interest.

Construction details are given here for making his Minooka Special from readily available inexpensive materials.

Performance is reported to be excellent with both the mobile and fixed-station versions of his design. Data are given also on basic antenna types in use by some of the leading "top band" DXers.

[Guestbook](#)

[Mail PI4CC](#)

THE MAIN ACTIVITY at W9UCW for the past 10 years has centered on 160-meter operation. The focus has been on antennas. Much of the study has been directed toward comparing the performance of vertical and horizontal antennas for various objectives. A further study has been made on portable, mobile, and small-lot antennas, including suitable antennas for use at DX locations. Three trips by the author to HK0 and HK1 locations motivated further investigations of portable antennas for use on 160 meters. Improved mobile operation was sought also, seeking solutions to the proplerres of efficiency, durability, bandwidth, ease of construction, and cost.

Inspiration for the design offered here resulted in past from the author's survey of antennas in use by 160 meter operators, worldwide. An extensive report was compited. It filled a loose-

leaf notebook! A boil-down of the most useful information resulted in an 11-page report which was made available to numerous amateurs. Subsequently, the writer was encouraged to submit some of the data for publication. Approximately 60 operators were polled, The following information from that inquiry should be of interest to those who are curious about "preferred" antennas for topband use. Question if you could put up any antenna for 160, what would it be? Result: 60% favored verticals, 30% said horizontals, and 10% indicated mixed feelings. (The term "vertical includes various configurations 1/4, 1/2, and 5/8 wavelength, vertical arrays, and inverted Ls.) Questions 2: "Comparing antennas that an average ham could build, do you prefer verticals or horizontals for 160? Result: 70% said vertical, 17% favored horizontal, 5% inverted L, 2% horizontal and vertical 2% inverted V and 3% had no opinion. Reason; given for the responses were, "Because of signal comparisons and past experience. A backyard-compatible vertical is more effective than a back-yard-compatible horizontal." Question 3: "Do you operate mobile on 160? If so, what is the antenna used?" Result: 3 used base-loaded verticals 8 used center-loaded ones and one employed a Heliwhip. Some of the operators used capacitance hats. Other questions in the survey dealt with receiving antennas, types of soil and terrain, besides requesting complete details of the present transmitting antenna.

The Minooka Special

The following is a description of an effective vertical antenna for 160 meters, designed with these objectives in mind.

- 1) Highly effective for 160-meter DX and local work.
- 2) Easy to build and adjust.
- 3) Very economical.
- 4) Fits neatly into back yard.
- 5) Reasonable bandwidth.
- 6) Good for portable and I)Xpedition work.
- 7) Can be scaled down for mobile operation.

The resultant antenna (Fig. 1) is top loaded inductively and can be built by anyone from readily available material. Only a dip meter and SWR indicator are needed for tune-up. Many versions were built and tested, ranging from 7-foot mobile types to 60-foot backyard or DXpedition models. They have been used with good results from 20 foot-wide backyards in cluttered Chicago,

to vast beaches on Carribean islands, and in South America. The fixed-tuned bandwidths vary from 10 kHz for mobile versions, to 50 kHz for the larger fixed-station models (SWR 2:1 or better).

Fig. 1 Electrical details of the Minooka special.

Table 2 gives specific information concerning dimetions X, Y and Z L2 may vary in size from 1 to 20 turns, and L3 will contain between 5 and 10 turns, typically. L2 and L3 are made from No.18 wire spaced 1/8 inch between turns. The coil diameter is 1-1/2 inches. Refer to text for tuning instructions.

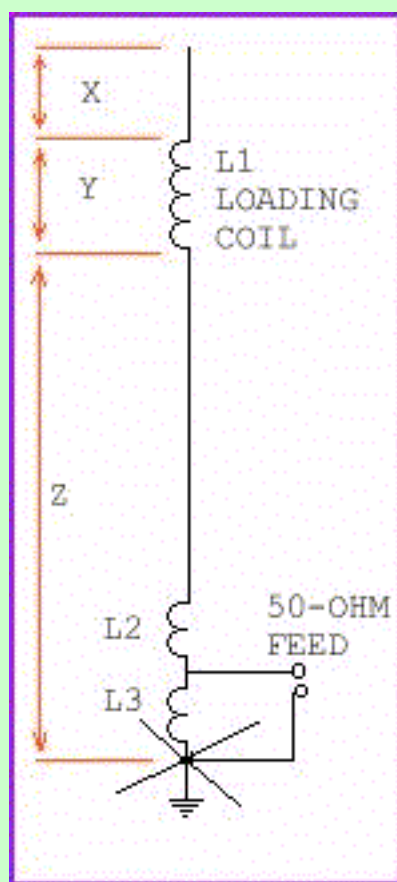

Table 2

| | | | | | | |
|-----------|-------|-------|-----------|-------|-------|-----------|
| X | 5 ft | 8 ft | 4 ft | 4 ft | 19 ft | 3 ft 3 in |
| Y | 2 ft | 15 in | 3 ft 6 in | 4 ft | 11 ft | 3 ft |
| Z | * | * | * | * | * | * |
| Wire size | No 20 | No 19 | No 18 | No 16 | No 19 | No 22 |

* mean as long as possible

Construction

The physical layout of the antenna is centered around the use of 3/4-inch-diameter rigid PVC water pipe. This sturdy tubing has an outside diameter of 1.038 inches. The inner diameter provides an "interference fit" for 1/2-inch EMT conduit (thinwall). A 3/8-24 nut is driven into a 5-inch length of conduit, then aligned and brazed into position. Next, the conduit is taper-ground and polished on the opposite end, then driven into the PVC tubing (see table of dimensions).

In the construction of mobile antennas another piece of conduit is driven into the bottom of the PVC coil form and a 3/8 - 24 bolt is brazed into the bottom end. The bolt will mate with standard mobile antenna mounts. For larger versions of the antenna the PVC material can be mounted in TV wasting, or whatever. A standard 8-foot stainlesssteel whip between 3 and 8 feet in length can be screwed into the top section. For home-installed versions of the antenna a three- or four-foot piece of thin-wall tubing can be used in place of the whip. This will save on the cost of materials, and will eliminate the need to have brazing done. The coil wire should be soldered to the conduit to assure a good electrical connection.

Adjustment

Pick a set of dimensions from the table which suits your application, but add a few inches more of coil turns (all turns close wound) than are recommended. This will allow leeway for pruning the system to resonance.

To simplify adjustment it is suggested that the system be assembled first with only the coil and top section (no base section). Place the antenna where it is in the clear (on the car or fixed-station site), and where it can be tuned against the proposed ground system - car body or ground radials.

A three-turn link should be connected temporarily between the lower end of the coil and the ground system. This will permit rough tuning of the system to resonance by inserting a dipper

coil into the link and adjusting the coil turns on the antenna until a dip is noted in the desired part of the band. Upon completion of the pruning the constructor can, if he wishes, cover the coil with weatherproof tape or shrink tubing. The antenna should be tuned for roughly 2000 kHz if the entire band is to be used. Adjust the resonance for 1850 kHz if only the low segment will be utilized.

Erect the antenna with all of its parts - coil, top and bottom sections - and insert inductors L2 and L3 of Fig. 3 as shown. With L3 temporarily out of the system, adjust L2 for the lowest value of SWR obtainable at the desired operating frequency. Then, place L3 back in the circuit and adjust it for an SWR reading of 1. Addition of the base section later on will not affect the resonant frequency of the overall system materially, provided the base section does not exceed, say, 60 feet.

The foregoing steps are used also in adjusting the mobile version of the antenna. However, because of the small size it is possible to adjust the antenna in completely assembled form. Only L3 of Fig. 3 is needed for mobile antennas. The main coil, L1, is adjusted for resonance, then L3 is set for lowest SWR. L3 can be mounted inside the trunk or under the bumper in a weatherproof enclosure.

For fixed-station operation it is recommended that a good ground system be employed. One should use at least 10 radials of say, No. 18 or larger wire, 10 to 50 feet in length. If you can manage 40 radials, 60 feet in length, all the better.

Concluding Comments

Three fixed-station versions of the Minooka Special have been tested and used at W9UCW. Each was compared against the regular antenna, which is a one-quarter wavelength vertical (130 feet high), and operates against a radial system that contains 12,000 feet of wire. The short verticals were always inferior to the big antenna by approximately 5 dB.

Using version No. 4 from the table (4-foot base section), the author worked W1s through W6s from the mobile setup. The rig

was an HW-18 transceiver. Contacts were also made with VP9 and KV4 stations from the car.

While DXing from San Andres (HK0) reports were received of signal strengths exceeding S9 plus 20 dB from Maine to Washington. Good reports were received from Europe also.

Because the loading coil acts as an rf choke at 3.5 MHz and above, several versions of the antenna have been used successfully from 160 through 20 meters with an appropriate L-network matching section installed at the base of the system.

Acknowledgements

The author wishes to express his gratitude to all who helped make this article possible particularly K9SKX, WA9EYY, and W9YYS, who assisted with the initial experiments on the Minooka Special. The participants in the antenna survey (a list too large to include here) deserve considerable thanks for their help as well.

The Battle Creek Special is worked out [here](#).



The OK1RR DX & Contesting Page is moved!

The new URL is:

<http://www.ok1rr.com>

You will be redirected in 10 seconds.
If not click on the link above.

Many thanks to Al Waller, K3TKJ for his long and outstanding service.



OK1RR DX & Contesting Page



Search this site:

Enter phrase:

Statistics

You are visitor #
since May 18, 2004
(in this domain)



Super Check Partial Databases Download

- [All callsigns](#)
- [Outside W/VE](#)
- [W/VE](#)
- [ARRL Sweepstakes](#)
- [Country data file](#)

Last revision:
Jun. 3, 2004

YPLOG Download

[Country Tables](#)

Last revision:
Jun. 28, 2004

[Master Database with Club
Memberships](#)

Last revision:
Aug. 8, 2004

[Rate this site](#)

The bands just now

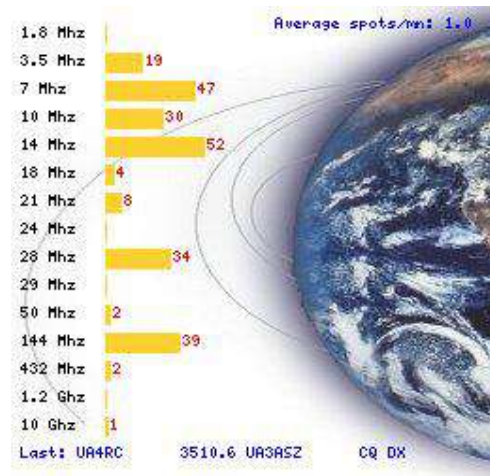

Welcome

This page is devoted exclusively to Amateur radio. You may find here some stuff concerning DX, CW and contesting.

If you have any great suggestions, feel free to [email me](#), and I'll probably feel free to ignore you.

How to use the 'The bands just now' chart?

This bar chart is based on the 250 lasts spots from the OH2AQ web cluster (fantastic tool!).

For each band a bar chart is drawn proportionally to the number of spotted DX informations. The absolute number of spots is noted in blue at the end of each bar. To see more spots from a particular band, click on the band indicator.

The last spot posted on the cluster is noted in blue at the bottom of the graph.

The Average spot/minute indicator is a calculated stamp, based on the 25 lasts spots.

by F5LEN

Data Sheets of 3225+ components

[Download in PDF format](#), many hard to find ones there! The download is limited to 10 items per day. Don't exceed this number, please, unless your IP would fail into banned list!

courtesy of [AMA-CB SERVICE](#) OK1DNH

PLC (Power Line Carrier) or PLT (Power Line Technology) - the end of Short Wave Bands?

They will use HF and VHF broadband systems. The outdoor power wires will serve as antennas, typically producing directivity and hugely strong increases in background noise for ham reception. ARRL did a study and included it in Comments in the FCC docket. Also, consumers will have equipment potentially susceptible to the ham signals. FCC rejected access to the 136 kHz band because of the risk of interference at 3mV/m, whereas the ham signals in HF/VHF will be at 30mV/m. ... [Download and read the set of basic documents.](#)

Notes on contesting software

Tired of non standard hardware devices or software solution? Writing a contesting program? [Read my notes](#) on contesting software and avoid common mistakes which I collected within past 12 years.

The DXZone

HAM RADIO INTERNET GUIDE

(with 10 = top)



On-line logs



Need a well featured Linux Live Distribution?
[TRY SLAX!](#)



Subscribe to **YPLOG mailing list**
Hosted by [eGroups.com](#)

[YPLOG archive](#)



I am **NOT** member of the Czech Radio Club



VNA - The Vector Network Analyzer by N2PK

Not satisfied with your MFJ-259B, Autek RF-1 or AEA CIA HF? Impossible to spend some 2 kilobucks for an advanced vector impedance analyzer? Do you want a highly interesting home brew project? Then visit [Greg Ordys \(W8WWV\)](#) and [Paul Kiciak's \(N2PK\)](#) web sites and learn more about the VNA - Vector Network Analyzer built and developed by N2PK. This is a homebrew VNA capable of both transmission and reflection measurements from 0.05 to 60 MHz, with about 0.035 Hz frequency resolution and over **110 dB of dynamic range**. Its transmission measurement capabilities include gain/loss magnitude, phase, and group delay.

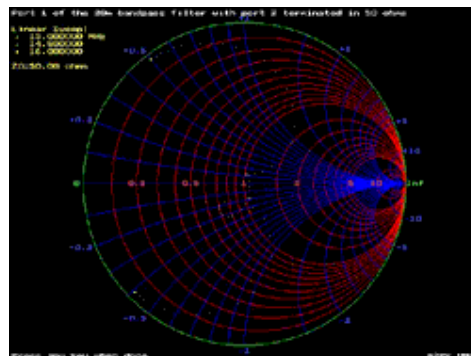
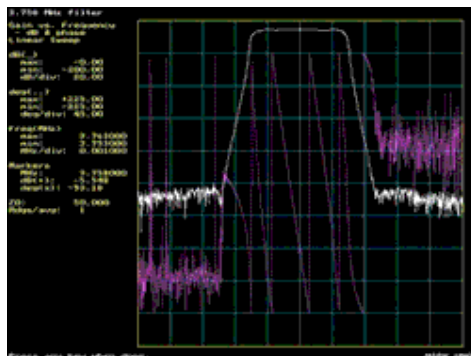

(click on images to enlarge)

Its reflection measurement capabilities include complex impedance & admittance, complex reflection coefficient, VSWR, and return loss. Unlike other impedance measuring instruments that infer the sign of the reactance (sometimes incorrectly) from impedance trends with frequency, a VNA is able to make this determination from data at a single frequency. This is a direct result of measuring the phase as well as the magnitude of an RF signal at each test frequency.

With optional narrowband extensions, this VNA can function through 500 MHz with some degradation in performance. Its custom software operates on DOS and Windows based IBM compatible PCs and communicates with the VNA through a parallel port. It is aimed at the serious experimenter with, at least, a basic understanding of transmission lines.

A sad story of the stolen name of the HSC

Are you a member of a Club? Are you a club representative? Who wants to evaluate a loophole in the law? [Read here.](#)

Join

You can become a member of the **OKDX Club** if you have worked and confirmed contacts with at least 100 DXCC countries.



Life Membership fee is 20 \$ (US). You will get nice Membership Certificate and as a benefit you can participate in OKDXC attractive Award program (to be announced soon) for Membership prices. [Visit our homepage!](#)

Send your Membership application (provide the number of your of DXCC or attach a GCR List of QSLs, please) to **OK1AU**.

OK1AU - Stanislav Veit, Sidliste 1454, 289 22 Lysa nad Labem, Czech Republic
e-mail : **OK1AU at qsl dot net**



1437

A1 - OPERATOR CLUB



731



61



130



1731



151



1994



223



24



QSL Manager Database available for download again!

The new version is still in process which take some time. My apologies for this inconvenience. If you want to read some news, [click here](#).

Software news

Software is like sex: it's better when it's free.

Linus Torvalds

- **HFProp** by Julian Moss, G4ILO is very nice hard-to-beat software. It employs Solar Flux or SSN value and both A and K displaying a particular propagation prediction chart to any point on any band at a glance. Many other programs are hard to use because it cost a significant effort to prepare a prediction to single point. HFProp combines a powerful beacon tracker with very good propagation calculator displaying the results on a Mercator world map. Julian says that it employs "a quite simplistic algorithm" but I can witness that it works at least in the same way as many of the highly priced programs. You can also directly compare the results with beacon availability, therefore confirm the prediction accuracy.

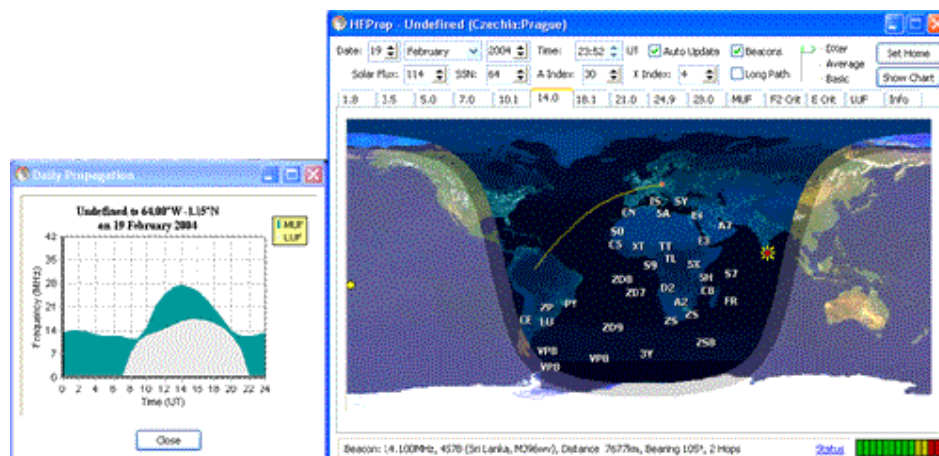

- **CT by K1EA** (DOS version) is **now free!** There are many new features including paddle support. Look for regular updates at the [CT home site](#).
- **Swisslog** by Walter Baur, HB9BJS for DOS is another addition to high value **free** programs. The latest DOS version 3D8a is probably the best logger for DOS which beats many known and expensive Windows logging programs.
- **4nec2** by Arie - a top grade **FREE** antenna analysis software based on true NEC2. Generates very nice color 3D pattern models, Smith chart, can optimize your antenna design and works up to 11000 segments, based on the RAM capability of your machine. The only disadvantage is that it uses NEC cards, you need a bit of experience with this ancient method. I believe this is the BEST antenna software!
- **NEC2 for MMANA** by Dimitry Fedorov, UA3AVR- a supplement to the famous MININEC implementation allowing NEC2 antenna analysis up to 3000 segments. Calculates also structures made of dielectric coated wires. Works with .maa files which can be prepared in the MMANA. There is a way to convert a MMANA file to the NEC card file (see above), simply rename the **Indata.txt** file generated by this program to a file with .nec suffix. An ideal companion to MMANA and 4nec2!
- **VUSC** (VHF - UHF - SHF Contest) by OK1DIX/N1GA is a TR-like contesting freeware with many advanced features. Visit the [author's web site](#) to obtain the most fresh version. The new **version** features:
 - Both modes on-line (during the contest) and off-line (evaluation after the contest) possible
 - Free log data editor
 - Multiband support (up to 8 VHF/UHF bands simultaneously on one computer)
 - Very high memory capacity (several thousands QSOs, all databases in RAM)
 - High data security in case of hardware/system failure

47



4358

Old Timers Club
since 1991



330



319



63



13



489

- o Database of stations/locators from previous contests available during the operation
- o QSL support with the database
- o CW keying with the paddle/keyboard option
- o Sound card support with voice memories for SSB
- o Rotator support with the very simple hardware interface
- o Network support (Ethernet or Token Ring) with non-limited number of computers
- o EDI support

Recent updates (last update undefined, undefined NaN, NaN)

Drag the text with mouse or wait until text scrolling.

Upcoming operations

| | |
|-------------|--|
| 01/01-31/12 | IOTA 2004 |
| till ?? | 9A/Z32FD: Pag Island (EU-170) |
| till ?? | RK3DZJ/1 and R3ARS/1: EU-147 and EU-066 |
| till 21/08 | 5X2A: Uganda * by K4ZLE |
| till 21/08 | TM3ID and TM6ANV: special stations (France) |
| till 22/08 | 7Q7HB: Malawi * by G0JMU |
| till 22/08 | SM0DTK/1: Gotland Island (EU-020) |
| till 23/08 | EI/KC8FS/p: Ireland |
| till 23/08 | MM0KAL, MM0XAU, MM5PSL: Sumburgh Head Lighthouse |
| till 24/08 | F/M0ARK/P: Re Island (EU-032) |
| till 24/08 | PJ: Bonaire (SA-006) * by I4ALU |
| till 25/08 | VY0CQ * by VE3ZCO |
| till 27/08 | 5U7DX: Niger * by PA5M |
| till 27/08 | EO60FO: special call (Ukraine) |
| till 27/08 | HH4/K4QD: Haiti (NA-096) |
| till 27/08 | OZ/DL2VFR: Bornholm Island (EU-030) |
| till 29/08 | F4AJQ/p: Noirmoutier Island (EU-064) |
| till 29/08 | SY2004PHG: Greece * by SV1AGU |
| till 31/08 | 406100BB: special station (Montenegro) |
| till 31/08 | ES1924: special event callsigns |
| till 31/08 | S790A: Mahe Island (AF-024) + Alphonse Island (AF-033) |
| till August | HE5IBC: special call (Switzerland) |
| till August | IR8M: Calabria region islands * by MDXC |
| till August | VY2MM: Prince Edward Island (NA-029) * by W3KHZ |
| till 01/09 | 9A2CY/P: Cres Island (EU-136) |
| till 01/09 | J42004A: Skopelos (EU-072) & Athens * by M0BBB |
| till 04/09 | SV5/SM8C: Kalymnos (EU-001) * by SM0CMH |



355



627



186



and others

till 07/09 VO2/K2FRD: Labrador (Zone 2) * by K2FRD
till 15/09 J42004: special prefix
till 15/09 RA3XR/0 and UA3YH/0: Dikson Island (AS-005)
till September 3D2EA: Viti Levu (OC-016) * by EC3ADC
till September ES7NY/2: Naissaar Island (EU-149)
till September FO5RN/p: Tahiti (OC-046), French Polynesia * by F5MJV
till September II0P: Sardinia (EU-024) * by IZ1EPM
till September YA0Y: Afghanistan * by DL5SE
till September YJ0XX: Vanuatu * by N5XX
till 31/10 SV0XAN/5: Dodecanese (EU-001) * by IK2WZD
till 04/11 II3T: Special event call * by ARI Trieste
till 15/11 SX2004 and SY2004: special prefixes
till November EL/EI5IF: Liberia
till 31/12 9A80ADE, 9A80Z, 9A80ABD: special event stations
till 31/12 HA2004EU: Special event call
till 31/12 HB75A: Switzerland (USKA 75th Anniversary)
till 31/12 HS72B: special call and licence (Thailand)
till 31/12 NL7AU: Upper Matecombe Key (NA-062)
till 31/12 OE80XRW: special event station
till 31/12 SG1RK: special event call (EU-020)
till 31/12 W1AW/90: ARRL's 90th anniversary
till December HF0QF and HF0POL: "Arctowski" Base (So. Shetlands)
till December OX2KAN: Special event station
till December VK0DX: Davis Station (Antarctica) * by VK4LL
till December VQ9LA: Diego Garcia (AF-006)
till December WL7CPA: Unalaska Island (NA-059)
till December YI9KT: Iraq * by SP8HKT
till December YI9MC: Iraq * by KC4MC
till January HA200CVM: special station (Hungary)
till March 2006 5H3HK: Tanzania * by JE3MAS
till March 2006 ZD8I: Ascension Island * by G8WVW
16/08-30/08 IG9/IK2MLR: Linosa (AF-019)
18/08-16/09 ZX350: special call * by PT2OP
19/11-21/11 SEANET Convention
20/08-22/08 4Z4DX: Jaffa Lighthouse
20/08-22/08 CS0RCL/LH: Berlenga Island (EU-145) & LH
20/08-22/08 DD6VSF: Ruegen Island (EU-057)
20/08-29/08 ER60EM: special station
20/08-22/08 F6HKS/p: Leucate LH
20/08-25/08 LA5UKA/p and LA9VDA/p: Gossen Island (EU-056)
20/08-22/08 OI3W: Ronnskar Island (EU-097) & LH
20/08-28/08 V47UY: Nevis Island (NA-104) * by KJ4UY
21/08-22/08 CU6/CU3AA and CU6/CU3EJ: Ponta da Ilha LH (EU-175)
21/08-22/08 CU6/CU3AA and CU6/CU3EJ: Sao Mateus LH (EU-175)
21/08-22/08 CX1TA: Cabo Santa Maria LH
21/08-22/08 ED8LGP: Barlovento LH (AF-004)
21/08-22/08 F5IRC: Antifer LH
21/08-22/08 F6KUM: Cap de l'Ailly LH
21/08-22/08 GB2DL: Dunollie LH
21/08-22/08 GB2ELH: Eshaness Lighthouse
21/08-22/08 GB2GNL: Girdle Ness LH
21/08-22/08 GB2LBN: Barns Ness LH
21/08-22/08 GB2LT: Turnberry LH
21/08-22/08 GB2MSL: Kinnaird Head Old LH
21/08-22/08 GB2NCL: North Carr Lightvessel
21/08-22/08 GB2RRL: Rubha Reigh Rua Reidh LH
21/08-22/08 GB2SHL: Stoer Head LH
21/08-22/08 GM3TKV/p: Kingston Beacon
21/08-22/08 HP2L: Gamboa LH
21/08-29/08 IA5/IK5WOB and IA5/IK5FTL: Isola d'Elba (EU-028)
21/08-10/09 IF9/I5RDF: Marettimo Island (EU-054)
21/08-22/08 II3T: Vittoria LH

21/08-22/08 IU1L: La Lanterna Lighthouse
 21/08-22/08 K8E: Eagle Harbor LH
 21/08-22/08 LT7W: Golfo Nuevo LH
 21/08-22/08 LU2DT/LH: Punta Mogotes LH
 21/08-22/08 LU: Atalaya LH * by Grupo Oeste
 21/08-22/08 Homecall/D: Recalada LH * by LUs
 21/08-22/08 Homecall/D: El Rincon LH * by LUs
 21/08-22/08 Homecall/D: Segunda Barranca LH * by LUs
 21/08-22/08 homecall/V: San Matia LH * by LUs
 21/08-22/08 homecall/V: Villarino LH * by LUs
 21/08-22/08 MM0MWW: Hoxa Head LH
 21/08-22/08 MM1HMY: Toward Point LH
 21/08-22/08 MM3STM: Ardrossan Pier Head
 21/08-22/08 OH/YL2FB: Soderskar LH
 21/08-22/08 PI4LDN: Noordwijk LH
 21/08 PI4VPO/LT: Stenen Baken LH
 21/08 PY7XC/p: Itamaraca Is. (SA-026)
 21/08-22/08 TF1IRA: Knarraros LH
 21/08-22/08 TO0FAR: Sainte Suzane LH (Reunion Island, AF-016)
 21/08-22/08 UU9JWM/P: Khersonesskiy LH
 21/08-22/08 VI2MI: Montague Island (OC-223)
 21/08-22/08 W2T: Tucker's Island Lighthouse
 21/08-22/08 ZV7AA: Natal LH
 21/08-22/08 International Lighthouse/Lightship Weekend
 21/08 Japan DX Meeting 2004
 21/08-22/08 SARTG WW RTTY Contest
 21/08-22/08 Seanet Contest
 22/08-25/08 2M0NJW and GM4RQI: St. Kilda (EU-059)
 22/08-06/09 9A: EU-136 * by IN3YGW and IN3DEI
 22/08 9H4GRS/P: Jordan's Lighthouse
 22/08 CQ0RLH & CT1GPX/LH: Cabo Raso Lighthouse
 23/08-31/08 AT0RI: Pamban Island (AS-???)
 24/08-31/08 XX9: Coloane Island (AS-075) * by JA0SC
 25/08-22/09 GB6LOP: special station (Liberation of Paris)
 26/08-07/09 8Q7JF & 8Q7GA: Maldives (AS-013) * by DL7JAN & DL3GA
 27/08-29/08 BV9A: P'enghu Island (AS-103)
 27/08-01/09 GB5FI: Flatholm Island (EU-124)
 27/08-29/08 R1MVI: Malyj Vysotsky (EU-117)
 28/08-04/09 HB0/HA4XG: Liechtenstein
 28/08-29/08 SCC RTTY Championship
 28/08-29/08 YO DX HF Contest
 29/08-12/09 K3GV/VY2: Prince Edward Island (NA-029)
 August UE9OWM/9: Altay-Himalaya Transasian expedition
 August ZK3: Tokelau Islands * by EC3ADC
 01/09-08/09 GB4IOM and GB4SPT: Isle of Man (EU-116)
 02/09-12/09 T98LBC: Bosnia & Hercegovina * by DL7AFS, DJ7ZG, Z31GX
 04/09-05/09 IQ7AF: Lecce - Salento DX Team Meeting
 04/09-05/09 TM5BDM: special station (France)
 04/09-18/09 TM8CDX: special station (France)
 04/09-05/09 All Asian DX Contest Phone
 08/09-18/09 SV8/ON4BB, SV8/ON5JE, SV8/ON5KH: Naxos (EU-067)
 09/09-23/09 7Q7CE: Malawi * by IN3VZE
 09/10-23/10 VK9L: Lord Howe (OC-004) * by Oceania DX Group
 10/09-18/09 FP/NN9K: Miquelon Island (NA-032)
 11/09-12/09 CIS DX Contest RTTY
 11/09-12/09 WAEDC - Worked All Europe DX Contest SSB
 18/09-20/09 FO/IT9YRE, FO/I1SNW, FO/IT9EJW: Hereheretue (OC-052)
 18/09-21/09 LX/ON6QX, LX/ON4LO, LX/ON6UM: Luxemburg
 18/09-19/09 MIA Contest (www.mdxc.org)
 18/09-19/09 Scandinavian Activity Contest CW
 19/09-21/09 SV8/ON4BB, SV8/ON5JE, SV8/ON5KH: Mykonos (EU-067)
 19/09 PSK31 Contest

20/09-30/09 CT9R: Madeira (AF-014) * by EAs
 21/09-28/09 GB2LI: Lundy Island (EU-120)
 22/09-29/09 PJ4/K9MDO, PJ4/N2WB, PJ4/W9ILY: Bonaire (SA-006)
 23/09-26/09 OJ0YC: Market Reef (EU-053)
 23/09-02/10 VP5/AH6HY: Turks Islands (NA-003)
 24/09-27/09 W4D: Dauphin Island (NA-213)
 25/09-26/09 Scandinavian Activity Contest SSB
 25/09-26/09 XX Italian HF-DX Convention (Bologna)
 18/10-23/10 V6O: Pulap Island (OC-155) * by W5BOS
 22/10-24/10 RSGB International HF & IOTA Convention
 23/10-02/11 FP/VE7SV: St. Pierre et Miquelon (NA-032)
 25/10-26/10 CQ World Wide DX Contest RTTY
 26/10-02/11 J75WX,J79AA,J79LR,J79CM,J79VL,J75J: Dominica (NA-101)
 30/10-31/10 VK4WWI/8: Elcho Island (OC-185) * by PA3EXX
 October-November 3B8MM: Mauritius (AF-049) * by DL6UAA
 October KH7K: Kure Atoll (OC-020)
 October TX0: Chesterfield Is. (OC-176) * by DL5NAM and others
 01/11-02/11 VK4WWI/8: North Island (OC-198) * by PA3EXX
 03/11-04/11 VK4WWI: Sweers Island (OC-227) * by PA3EXX
 08/11-12/11 VK4WWI/p: Marion Reef (OC-???) * by PA3EXX
 22/11-09/12 VK9XG: Christmas Isl. (OC-002) * by W0YG
 28/11 3D2FI: Viti Levu (OC-016), Fiji * by G0UIH
 29/11-05/12 3D2FI: Nacula Island (OC-156), Fiji * by G0UIH
 November PT2GTI: "Comandante Ferraz" Station, South Shetlands
 06/12 3D2FI: Viti Levu (OC-016), Fiji * by G0UIH
 07/12-10/12 3D2FI: Beachcomber Island (OC-121) , Fiji * by G0UIH
 11/12 3D2FI: Viti Levu (OC-016), Fiji * by G0UIH
 21/01-04/02 3Y0X: Peter I Island (AN-004)

source: 425 DX News



Copyright OK1RR.

Best viewed with any Java capable browser and 1024x768 resolution.

[The WE6W Hi-Voltage 160 Meter QRP Loop Ant.](#)
[Homebrewed Link-coupled experimental tuner.](#)

[Standard Double Bazooka design!](#)

[Std. Bazooka I built.](#)

[Std. Bazooka compared to my dipole](#)

[Folded Bazooka! 300 Ohm feed!](#)

[WE6W Field Day Antena design!](#)

[Build a Sterba Curtain Antenna!](#)

[Notes: Sterba Beamwidth/Gain](#)

[St. Louis Vertical](#)

[Broadband Antennas](#)

[The A613 broadband bow-tie](#)

[W4RNL L. B. Cebik: Antenna articles/Software!](#)

[Back to we6w's Home Page](#)

THE DOUBLE BAZOOKA

End Detail

Tie both ends together
if using twin lead.
Instead of twin lead I used
1 piece of #12 copper wire

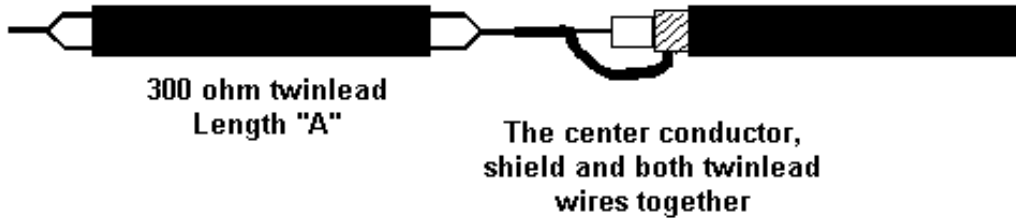

300 ohm twinlead
Length "A"

Coax Length "B"

The center conductor,
shield and both twinlead
wires together

HAM UNIVERSE

SET YOUR SIGHTS ON BETTER QSO'S

Notes on Assembly:

On the cable ends you do not need to use twin lead. You can make these antennas using a single piece of 12 gauge copper wire for each end,, you can also use ladder line etc. I would advise using heavy end wires for strength purposes. To prevent the joints from breaking especially for long lengths, I picked up some 1/2 inch PVC pipe and end caps. I cut the PVC so it would overlap a few inches on the joints. I then glued the end caps on. Place the PVC between the joints and secure with regular screw hose clamps. Put the clamps close to the end caps and it will give a strong joint. Do this for the center also.

About The Antenna

The Double Bazooka Dipole is a very efficient **single band antenna** which is very quite, and does not require the use of a balun. This antenna consists of coax (RG58) with the shield split at the center and the feedline attached to the open ends. **Do not break the center conductor.**

With the feedline attached directly to the two open ends this acts as a half wave dipole along with the open wire end sections. This antenna can be cut for any operating frequency and is broad banded. It can be mounted as a flat top or an inverted vee and will handle the legal limit.

As with all antenna projects, you may have to tune length for best swr and select materials that are easily obtainable.

EXPERIMENT! EXPERIMENT! EXPERIMENT!.

AN EXAMPLE ANTENNA

75 METER GENERAL BAND CENTER (3.925 mhz)

LENGTH "B" = $325/\text{freqmhz} = 82.8$ FEET (aprox 82 feet 9 1/2 inches)

LENGTH "A" = $460/\text{freqmhz} = 117.20$ feet 2 1/2 inches minus length "b" (82.8feet) = 34.4 feet divided by 2 = 17.2 feet

TOTAL ANTENNA LENGTH = 117.2 feet 2 1/2 inches (aprox)

[BACK TO ANTENNA LAB](#)

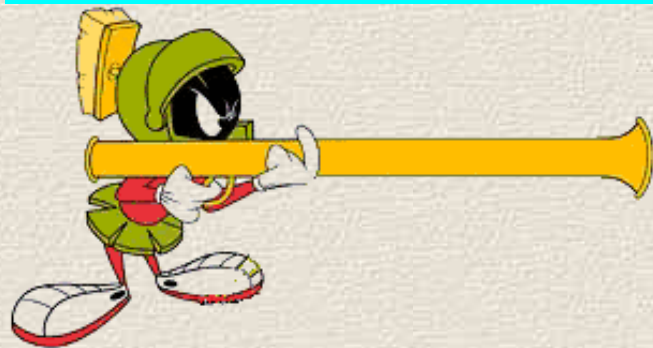
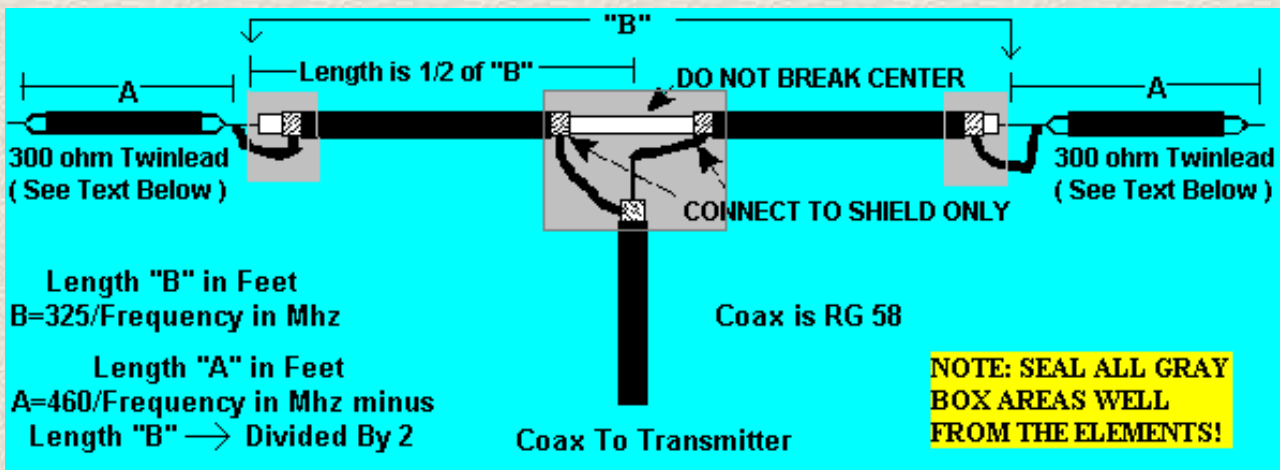

© 1996 Warner Bros.

Why pay full retail for inkjet supplies when you can save between 50%-70%! [Click here and start saving!](#)

[Transmit ANY audio](#) (like your Ham Radio, CD player, computer sound card, TV, or tape deck) to ANY FM radio!

[etronics.com](#)

KB1GW's collection of Beverage Antenna Information

[KB1GW Home](#)

[RadioSport](#)

[Photo Scrapbook](#)

[Fun Links!](#)

[Software page](#)

[Misc. Radio Links](#)

[Sources of Gear](#)

[Airline Web pages](#)

[TS-850 Mods](#)

Introduction

The Beverage (or "wave") antenna was invented in the early 1920s by Dr. Harold H. Beverage. It was first discussed in a paper titled "The Wave Antenna - A New Type of Highly Directive Antenna" written by Beverage, Chester W. Rice and and Edward W. Kellogg for the journal of the American Institute of Electrical Engineers (Volume 42, 1923). The paper discusses testing longwave antennas (7,000 to 25,000 meters; 12-43 kHz) that were 7 miles (11 km) long. This work was done at Riverhead, Long Island, NY, and mentions "shortwave" tests around 450 meters (665 kHz) as a practical upper limit in subsequent experiments. While others have since written about the antenna, if you can find a reprint of this original work in a research library, you'll find the paper is fascinating reading.

In 1938, the Radio Institute of America presented Dr. Beverage with its Armstrong Medal for his work in the development of antenna systems. The Beverage antenna, the citation said, was "the precursor of wave antennas of all types." Dr. Harold Henry Beverage, Stony Brook, NY, USA, passed away on January 27, 1993 (at age 99).

A classic Beverage receiving antenna requires a lot of space. It is a long wire, one or more wavelengths long, mounted near to the ground and oriented in the direction of the desired reception. A nominal 9:1 balun is required at the juncture of the wire and 50- or 75-Ohm coaxial feedline. The far end is terminated with a nominal 600-ohm resistance. (When available land will not permit the installation of a "full length" Beverage, some people install "short" Beverages, ranging in length from about 300 feet up to 600 feet or so.)

The Beverage antenna is highly directional, responsive to low-angle signals, has little noise pick-up, and produces excellent signal to noise ratios. Some say the frequency range suitable for Beverage antennas ranges (from an Amateur Radio viewpoint) from 1.8 MHz on up to about 7 MHz or so... However, consider the following from Frank, W3LPL:

Subject: Beverage antennas effective on entire HF range

From: Frank Donovan (donovanf@jekyll.sgate.com)

Date: October 22, 1995

Organization: (Usenet's) rec.radio.shortwave

Properly designed Beverage receiving antennas are very effective across the entire HF frequency range. At the W3LPL DX contest station we use Beverages from 1.8 to 14 MHz, and during the sunspot maximum we used them up to 28 MHz!

Beverage arrays (multiple Beverages designed to operate as a phased array) are even more effective on HF. I've seen Beverage arrays with as many as 128 individual Beverage elements, each 220 feet long and 4 feet high.

"How To" articles:

An original article by KB1GW: ["Beverage Notes"](#)

(Note: This article originally appeared in the YCCC newsletter: ["Scuttlebutt;"](#) April 1997.)

And, another Beverage article by KB1GW (with guest, K4VX):

["More Beverage Notes"](#) -- Copyright: August, 1997.

(Note: This article originally appeared in the YCCC newsletter: ["Scuttlebutt;"](#) October 1997.)

An article by K5ZD: ["A \\$50 Beverage"](#)

(Note: This article originally appeared in the YCCC newsletter: ["Scuttlebutt;"](#) October 1995 .)

A link: ["W3LPL on Beverages"](#)

"Frank Donovan, W3LPL, discusses beverages on the CQ-Contest reflector.

This is a reprint of Frank's message," along with a nice picture of W3LPL's QSL card!

Contest-reflector postings from W3LPL on Beverages:

[Close-spaced Beverages](#)

[Phased Pair of Beverages](#)

[Terminating / Sloping Ends of Beverages](#)

[Minimum and Optimum Lengths for Beverages](#)

New! [W3LPL Receiving Filters...](#)

"These filters have several applications:

Preventing interference -- or receiver damage -- from strong nearby signals in a multi-transmitter contest station (or field day, etc.), or to reduce interference in the 160M band from nearby AM broadcast stations operating below 1500 kHz."

"Sharing an antenna among up to four receivers on separate ham bands; specifically a diplexer (constructed from two LPL filters) is used when you want two receivers -- on separate bands -- to share a common antenna, any multi-radio contest station can benefit from sharing Beverages among radios with less loss than the typical 3 dB power splitter."

A link to [a 1968 interview with Dr. Harold H. Beverage](#)

"Dr. Beverage was formerly director of radio research for RCA Laboratories and also was vice-president in charge of research and development for RCA Communications. During the interview, Dr. H.O. Peterson came in and joined the interview. Dr. Peterson was formerly in charge of the Reception Laboratory at Riverhead. The first RCA Laboratory was established by Beverage and Carter in a tent at Riverhead [NY] in 1919. The interview describes the events leading up to the formation of RCA in the autumn of 1919, the invention of the wave antenna, and first diversity reception. It also describes Dr. Hansel's development of the first crystal controlled transmitter and the first 15 meter transmitter. Some of the personal characteristics of Marconi, Dr. Alexanderson, Roy Wegan, Dr. Hansel, Major Armstrong, President Wilson, and others are discussed."

And, a link to a [1992 interview with Dr. Beverage](#).

Receive antenna's--related resources:

Hardware:

A link to: [Oak Ridge Radio, in Littleton, MA](#)

"Manufacturer of quality radio receiving equipment for DXing the shortwave and mediumwave bands." Including an analog opto-isolator to make remote-controlled variable Beverage-terminating resistors. And "RCT Beverage antennas:" Complete remote-controlled-termination Beverage antenna kits.

Industrial Communication Engineers, LTD.
PO Box 18495
Indianapolis, IN 46218-0495
Tel. 800-ICE-COMM (800-423-2666)
Main Office 317-545-5412

Cust Serv (parts) 317-547-1398
Fax 317-545-9645
Telex I.C.E. 27-440

ICE offers a Model 180A matching box for \$39 (plus \$4.50 for shipping). The 180A has taps to select 50 or 75-Ohm coax feedlines; and taps to match 300/450/600 or 800-Ohm Beverage antenna loads. The 180A has dc blocking capacitors and a gas-discharge lightning protection system. ICE also sells a Model 181A (\$39), which allows you to apply a dc voltage into your Beverage for remote switching. Like the 180A, the '181A has a gas-discharge protection system. Finally, they offer a Model 185A "resistive load" to terminate your Beverage with. It has same high-impedance taps as the Model 180A and it costs \$34. These units are rated for 10 W of continuous RF and 100 W on peaks. (I was told that these ratings are not specified for transmitting into the boxes. Rather, they are what the boxes can withstand when your Beverage picks up energy from nearby transmitting antennas.) All of these boxes are made of 1/8-inch extruded aluminum (milled and tapped). And, if you're looking to buy American, they're all made in the USA.

A link to: [ByteMark Corporation](#) in Orlando, FL; tel: (800) 679-3184 (They sell Amidon stuff.)

Among other things, they offer high power ununs designed by Dr. Jerry Sevick, W2FMI...

Features:

- Broad Bandwidth (1 MHz up to 50 MHz)
- Low energy loss (<0.2 dB)
- Aluminum casing with SO-239 connectors on inputs and outputs
- Dimensions: 4 inches x 2 inches x 2.8 inches (same for all models)

Typical Applications: Matching unbalanced 50 ohm coaxial cable to:

- Ground fed antennas - shortened verticals, vertical beams, slopers and inverted L's
- use 4:1 HCU50, 1.78:1 HDU50, etc.
- Shunt fed towers performing as verticals - use 1.56:1 HDU50
 - Beverage antennas - use W2FMI-BEV

"The unun should find some important applications. Until recently, they have been literally impossible to obtain. But now they can be designed to match 50-ohm cable to loads as small as 3.125 ohms and as high as 800 ohms (both unbalanced loads). They can come in low-power and high-power versions as well as

multimatch designs. An important application for ununs is to match 50 ohm cable to the input impedance of ground-fed antennas such as verticals, slopers, inverted L's and towers performing as verticals. Since ground losses play a large role with these systems, a knowledge of the input impedance of the antenna as well as the ground loss is important in determining the optimum impedance ratio. Also, a high impedance, multimatch unun can be easily designed to match 50 ohm cable to the input impedance of Beverage antennas."

"Baluns (balanced to unbalanced transformers) and ununs (unbalanced to unbalanced transformers) belong to a class of matching devices known as transmission line transformers. They transmit the energy from input to output by a transmission line mode instead of by flux linkages as in the case of conventional transformers. When properly designed, they can have extremely high efficiencies and very broad bandwidths."

A 2:1 unun is a good choice for feeding a 1/4-wavelength "Inverted L" type antenna. For example: One 2:1 unun they offer has 22/25-Ohm taps on one side, and a 50-Ohm tap on the other side. This aluminum cased model (HDU100) has female SO-239 connectors at each end, too.

C&S Engineering
9229 Goldenrod Drive
Fort Wayne, IN 46835
Phone Orders: (219) 485-1458

E-mail: [Chuck, N8BYI](mailto:Chuck.N8BYI)

Web: [C&S Engineering](http://www.candse.com)

C&S Engineering offers several products, including their "Front End Saver (FES)," available as a kit (\$22.95); pre-populated circuit board (\$29.95); or built, tested and cased (\$49.95), plus shipping costs. The FES "protects your receiver when you operate on the aux. (RX) antenna. A must for 80m and 160m operators." (The FES was described in *CQ Magazine*, February 1997, p 32.)

In addition, C&S offers a "160 Meter Preamp," (also available for 80 meters). Single-band preamps are available, in kit form (\$29.95); built, tested, and cased (\$59.95); or for 80 *and* 160--switchable--(\$99.95). These preamps offer tuned inputs and outputs. "Amplify sig not noise. Over 25 dB gain, lo noise, gain control. A must for Beverage and loop antennas." (The 160-meter preamp was featured in the October 1989 issue of *Ham Radio Magazine*, in an article by Gary Nichols, KD9SV.)

Here's an ad I saw in the "Ham Ads" in the back of *QST* Magazine:

"BEVERAGE matching transformer kits, 160/80/40 DX reception.
\$12 each, 3/\$29. Lectrokit, 401 W. Bogart, Sandusky, OH 44870."

ARRL Books:

"Low Band DXing:"

Low band antennas (TX and RX, including Beverages), operating techniques; by ON4UN

"DXing on the Edge--The Thrill of 160 Meters:"

160-meter operating, TX and RX antennas, and more; by K1ZM (includes an audio CD, too).

Beverage antenna articles--from *QST*:

"Beverage Antennas for Amateur Communications," *QST* Magazine, January 1983, pp. 22-27. (Belrose, Litva, Moss, and Stevens)

"The Classic Beverage Antenna, Revisited," *QST* Magazine, January 1982, pp. 11-17

(H. H. Beverage and Doug DeMaw).

"The Wave Antenna for 200-Meter Reception," *QST* Magazine, November 1922, pp. 7-15

(H.H. Beverage).

K9AY receiving-loop antenna article--from *QST*:

"The K9AY Terminated Loop--A Compact, Directional Receiving Antenna"

QST Magazine, September 1997, pp. 43-46 (Gary Breed).

"EWE" receiving antenna articles--from *QST*:

"Is This EWE For You?," *QST* Magazine, February 1995, p 31 (Koontz).

"Feedback," (Re: Is This EWE For You?), *QST* Magazine, April 1995, p 75 (Koontz).

"More EWE's For You" *QST* Magazine, January 1996, p 32 (Koontz).

Further reading:

"The Beverage Antenna Handbook"

Victor Misek, W1WCR

142 Wason Road

Hudson, NH 03051

"Beverage and Longwire Theory"
National Radio Club
P.O. Box 164
Mannsville, NY 13661

"The Beverage Antenna"
Popular Electronics magazine
January 1998 issue; pages 40 to 46
An article by:

[Joseph J. Carr, K4IPV](#)

Receive-antenna-related links:

["Who's Who on the TopBand"](#) by VK2ICV:

Lists the top-gun DXers on 160 meters, by number of countries worked on our "TopBand."

["Terminated Shortwave Antenna"](#) by Cyril Dufault, VA2CJD:

" -- the "baby" [B]everage antenna for everybody --"
(It's a terminated loop, actually.)

["T2FD -- The Forgotten Antenna"](#) About the terminated, tilted, folded dipole,
this article appears on the web page of the ["Nordic Shortwave Center:"](#)

"An early discussion of the T2FD appeared in the June 1949 issue of *QST*. The author of that article followed up on the T2FD in the November 1951 issue of *QST*, and in the February 1953 issue of *QST*. A more recent article on the T2FD appeared in the May 1984 issue of *73 Magazine*."

You'll also find links to how to construct a T2FD, using a 4:1 balun, 390-Ohm resistor, and 75-Ohm RG-59 type coaxial cable; And, a comparison of an 60 meter band T2FD (for SWLs), to a 500-foot-long longwire-type receiving antenna, and to a 50-foot-long random-wire antenna.

Page author: Glenn Swanson, KB1GW

kb1gw@snet.net

[KB1GW Home](#) | [RadioSport](#) | [Software](#) | [Sources of Gear](#) | [Photo Scrapbook](#) | [TS-850 Mods](#)



The Birdcage Antenna



L. B. Cebik, W4RNL

The folded X-beam derives its existence from the G4ZU Birdcage antenna. W2EEY viewed the X-beam as half a Birdcage.(1) Although this is historical fact, the logic of antennas goes the other way round: the Birdcage is a double folded X-beam. For reference, Figure 1 provides a free space pattern of an X-beam tuned for maximum front-to-back ratio.

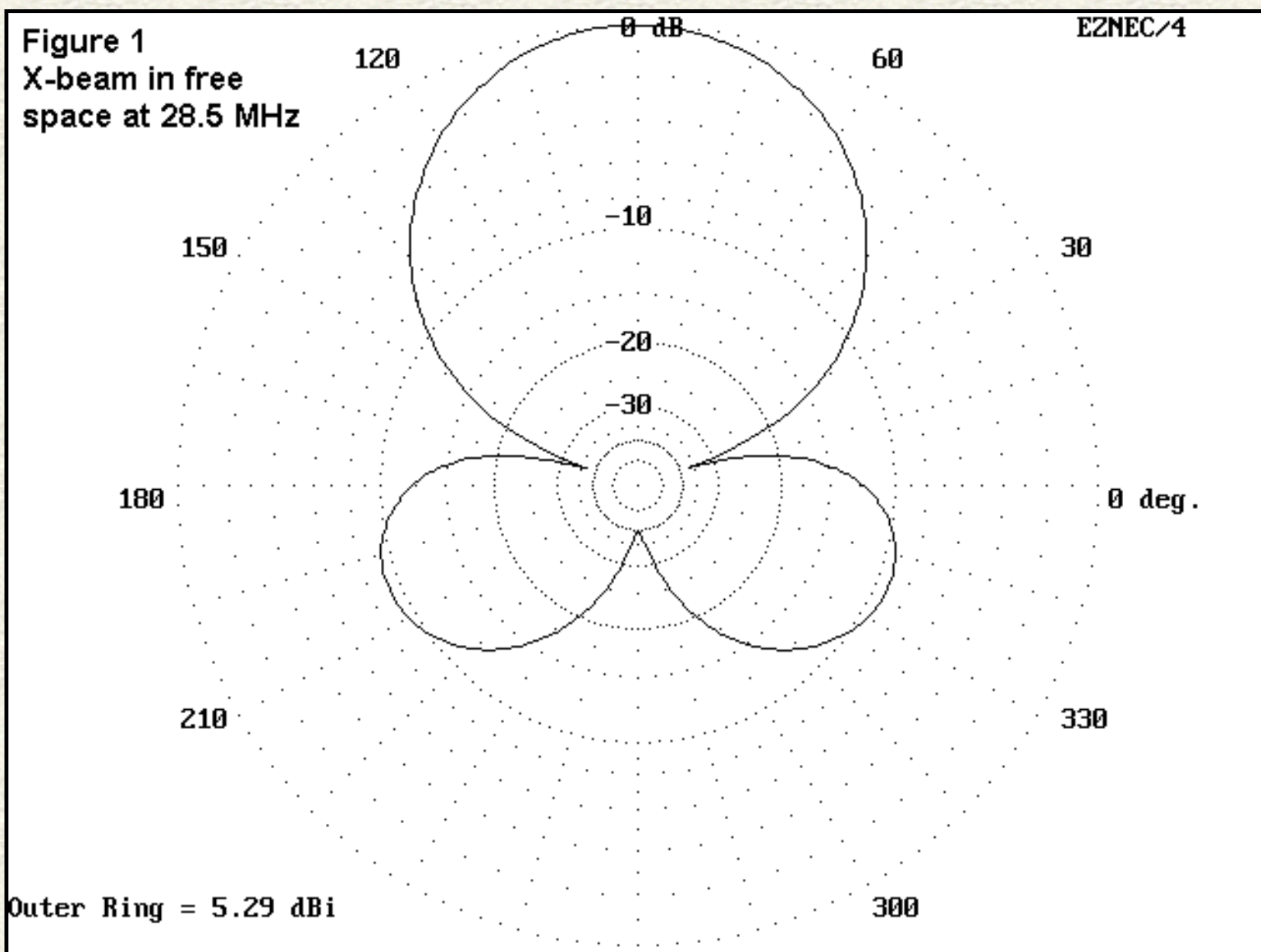

We may legitimately ask, how much better does the whole Birdcage work compared to an X-beam? When Dick Bird,

G4ZU, published his work in 1960, he made some fairly extravagant claims for the antenna, claims that led him to patent it.(2) At this distance and with the calculating power made available by NEC and its offspring, we may decide that the claims for his antenna (and those of many hams who built one) reflect more accurately the low state of home-brew Yagi and quad construction of the time than they do contemporary comparative performance. Models of the Birdcage show little advantage over the X-beam and exaggerate some of its limitations.

Bird graphically demonstrated what he took to be the principles of the Birdcage by beginning with the bidirectional pattern of the dipole. Folded into a Vee, the antenna would show, according to his sketches, a strong lobe out the open end and a weak lobe off the apex. Add a Vee reflector (pointed the other way to make an X), double the assembly a quarter wave above or below, bend the X-arms vertically to meet each other as phasing lines, and the Birdcage is born. Figure 2 shows the outline of the Birdcage, with identification of each relevant dimension.

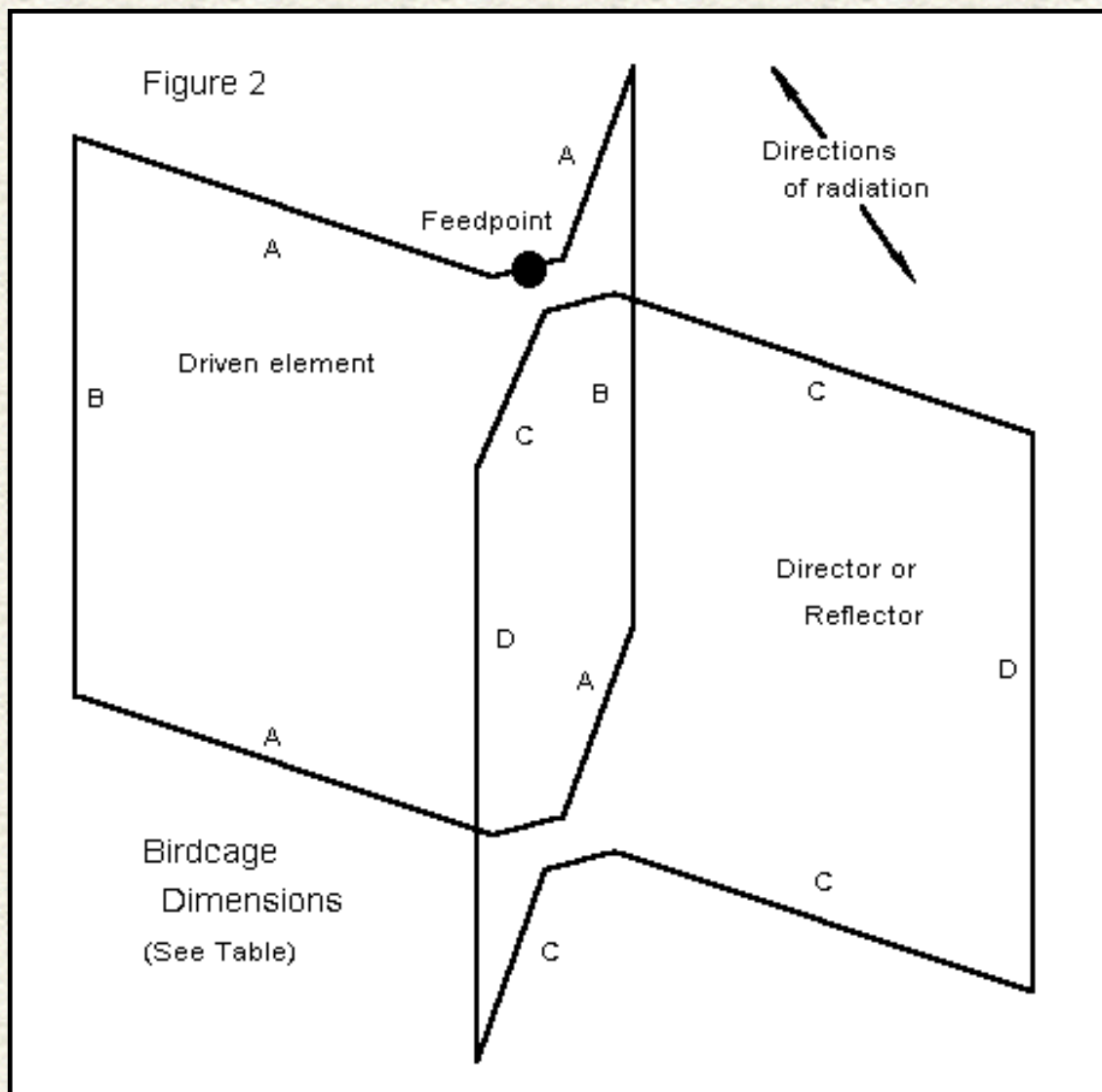

Unfortunately, the seeming flaw in the reasoning begins with the Vee itself. Short Vees do not cancel the radiation off the backsides of the elements (the outsides of the V). Thus are born the uneliminable quartering lobes of the X-beam and even larger lobes for the Birdcage.

Birdcages come in two forms: with a reflector and with a director. Table 1 shows 10-meter models of each beginning with a self-resonant Birdcage with equal-size elements derived from data given in 1960's literature.(3)

Table 1. Modeled Dimensions of the Birdcage Antenna

| Dimensions | DE Arm (A) L (ft) | Parasitic (C) L (ft) | Vertical (B and D) L (ft) |
|--------------------------|----------------------|-------------------------|------------------------------|
| Basic Birdcage | 5.05 | 5.05 | 8.666 |
| DE and Refl Resonated | 4.95 | 5.26 | 8.666 |
| DE and Dir Resonated | 5.16 | 4.91 | 8.666 |

Note: all models used #14 copper wire in free space at 28.5 MHz on NEC-4.

Figure 3 shows the performance in free space of the basic Birdcage--a nice 4-leaf clover.

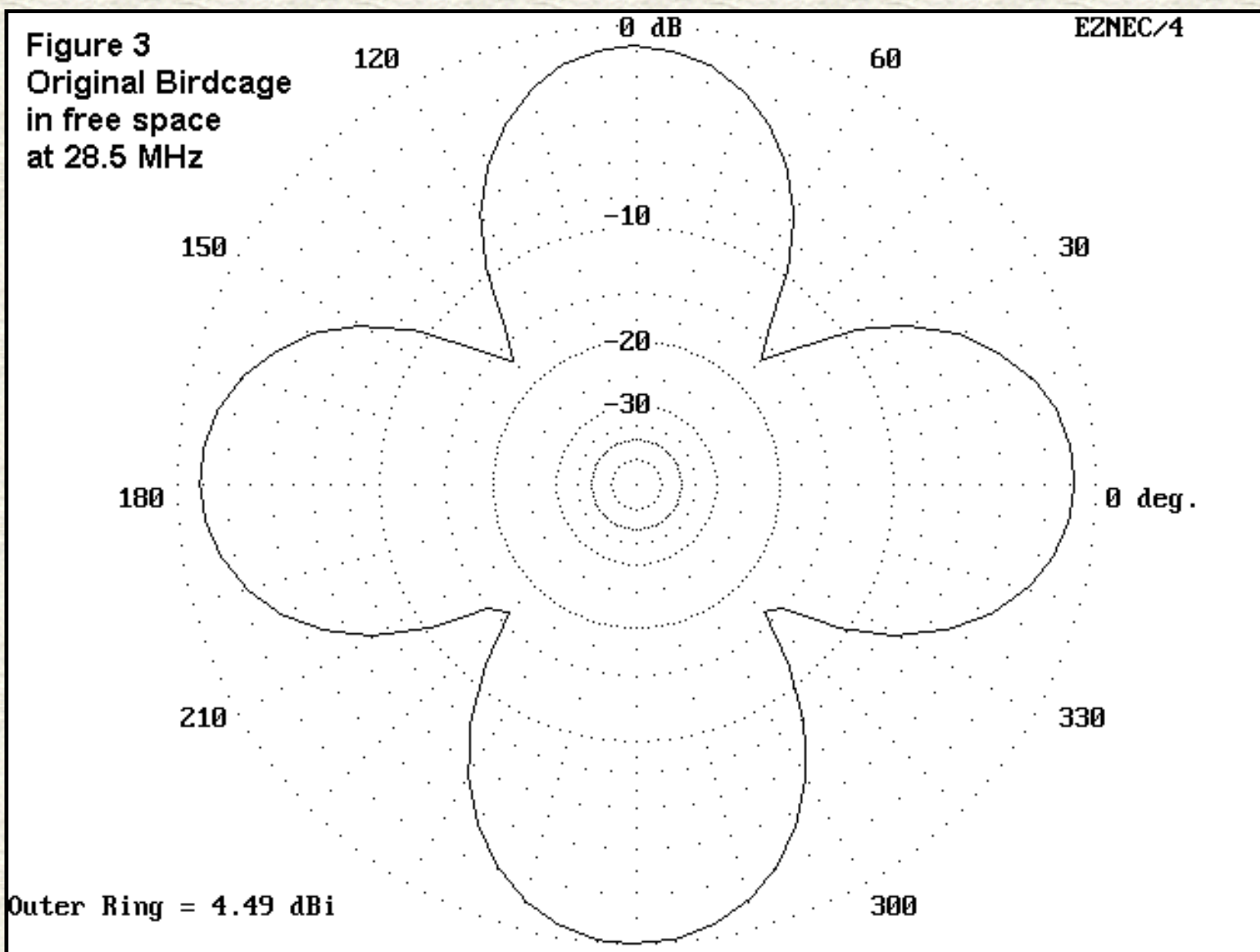

G4ZU favored the reflector version, which is perhaps the worse performer of the two possible versions. With a

forward gain in free space of under 6 dBi and a front-to-back ratio of about 8 dB, the beam is not the equal of a 2-element Yagi or even of the X-beam. Figure 4 shows its performance in free space.

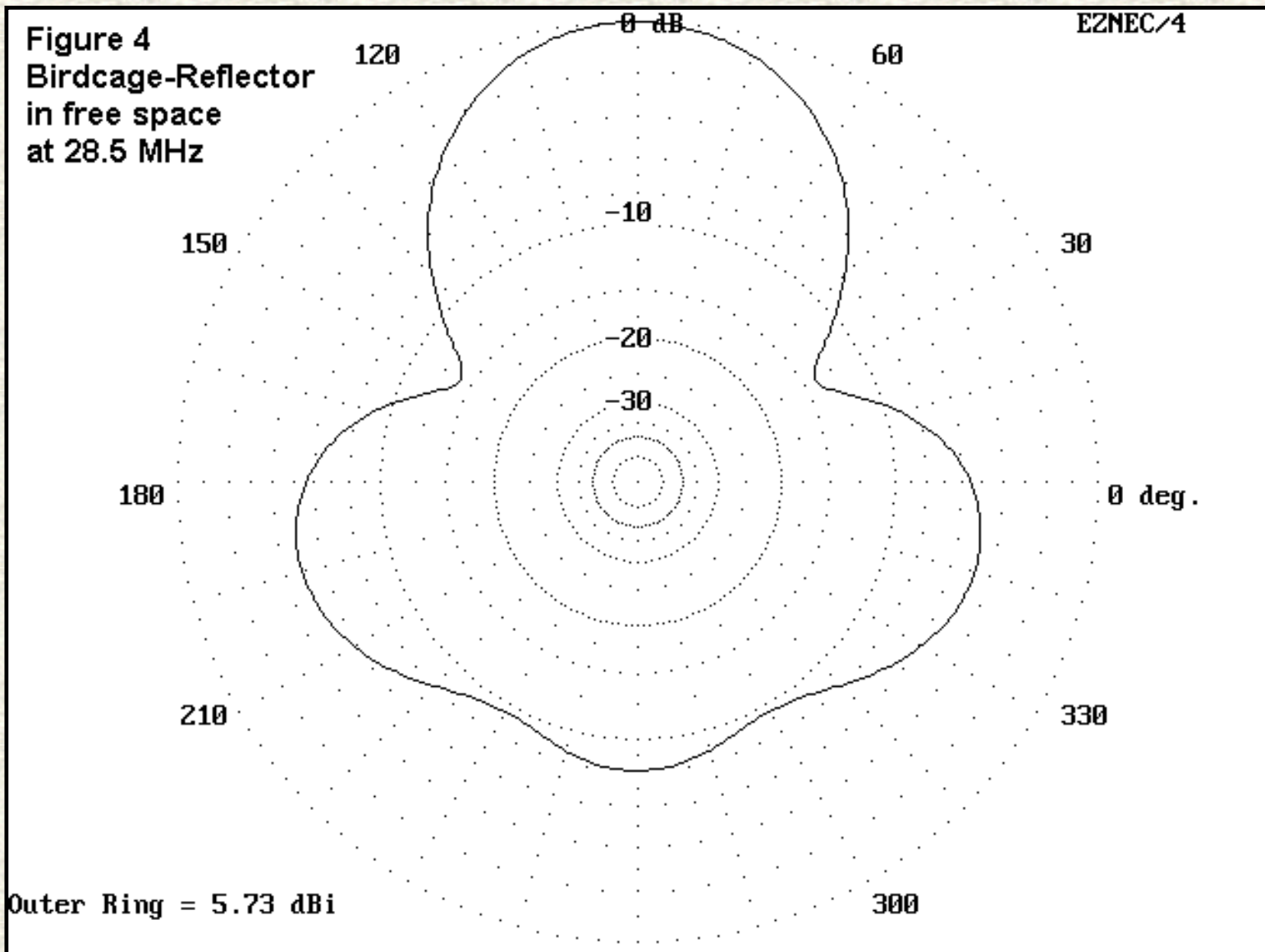

The director version that parallels the development of the X-beam provides more gain and front-to-back ratio: 6.3 dBi and 17 dB, respectively. Figure 5 shows its performance in free space. The direction is reversed, since I simply re-dimensioned the reflector to form a director.

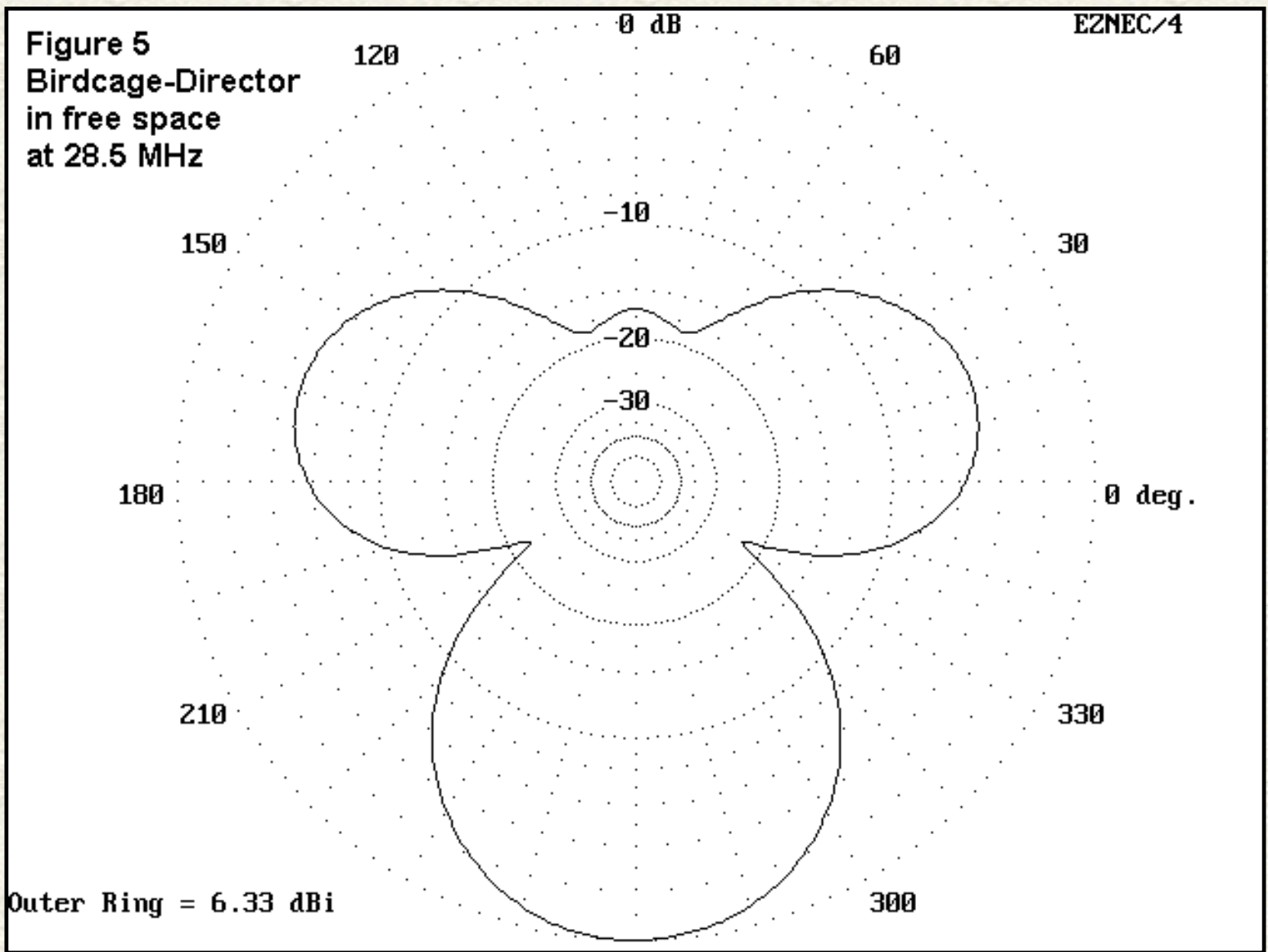

As shown in Table 2, the figures for the directed Birdcage surpass both the X-beam and the 2-element Yagi by a small bit, while the reflected Birdcage leaves much to be desired.

Table 2. A Comparison of Antenna Performance

| Antenna Type | TO Angle (degrees) | Gain (dBi) | Front-to-Back (dB) | Feedpoint R ñ jX (Ohms) |
|---------------------------|--------------------|------------|--------------------|-------------------------|
| A. Free Space | | | | |
| Birdcage: DE + Ref | -- | 5.8 | 8.0 | 34 - 0 |
| Birdcage: DR + Dir | -- | 6.3 | 16.9 | 40 + 4 |
| Folded X-Beam | -- | 5.3 | 39.1 | 37 - 3 |
| B. Height = 5/8 wl | | | | |
| Birdcage: DE + Ref | 22 | 10.5 | 8.0 | 31 - 3 |
| Birdcage: DR + Dir | 22 | 11.0 | 17.1 | 40 + 3 |
| Folded X-Beam | 23 | 10.5 | 21.8 | 35 + 0 |
| 2-El Yagi | 23 | 11.3 | 10.9 | 34 - 5 |
| 2-El Quad | 22 | 11.7 | 18.3 | 97 - 3 |
| C. Height = 1 wl | | | | |
| Birdcage: DE + Ref | 13 | 11.3 | 8.6 | 32 - 2 |

| | | | | |
|---------------------------|-----------|-------------|-------------|---------------|
| Birdcage: DR + Dir | 14 | 11.8 | 17.0 | 39 + 2 |
| Folded X-Beam | 14 | 10.8 | 31.7 | 33 - 1 |
| 2-El Yagi | 14 | 11.7 | 13.5 | 35 + 0 |
| 2-El Quad | 13 | 12.4 | 17.9 | 92 + 8 |

Note: TO angle=the angle of maximum radiation at which azimuth readings of calculated gain and front-to-back ratio were obtained. All calculations via NEC-4.

The pattern of the Birdcage in either version does not meet today's standards of front-to-side ratio or front-to-rear ratio. The quartering rear lobes of the X-beam become virtual side lobes of the Birdcage and are only down from the main lobe by some 4 to 5 dB in the either version. There is little QRM-rejection potential, especially in the reflector version. Over real ground, the pattern devolves into a mound of whip cream. However, over real ground, the director version tends to push its side lobes to the rear, and the pattern begins to resemble that of the folded X-beam.

Like the folded X-beam, the Birdcage retains its most optimal pattern only over a small portion of the band of design. The reflector version rapidly grows a tail below design frequency, while the director version grows its tail above design frequency. The SWR bandwidth is also narrow, less than 0.5 MHz at 10 meters for a 2:1 SWR. However, the complex structure of the Birdcage is less amenable to a tunable parasitic element than is the simpler X-beam.

All in all, the additional complexities of the Birdcage are not warranted by a significant increase in performance over the X-beam. Gain aside, the side and rear performance of the antenna falls far short of other compact designs. Consequently, while that antenna has a great name and an appealing look, performance models do not recommend the investment of time and resources in this antenna. In some ways, it is a shame to discover this: G4ZU contributed extensively to amateur practice in the field of antennas. Although the Birdcage antenna has had its day, Dick's other work--and his example--will long endure.

Notes

- (1) John Schultz, W2EEY, "The G4ZU X Beam for 20," CQ (June, 1965), pp. 26- 28, 102.
- (2) Dick Bird, G4ZU, "The G4ZU 'Bird Cage' Aerial," CQ (April, 1960), pp. 40-42, 117.
- (3) See George Cousins, VE1TG, "The Tri-Band Birdcage," CQ (July, 1963), pp. 30-33. Another brief reference to the antenna occurs in Orr and Cowan, Cubical Quad Antennas, 3rd Ed. (Lakewood, NJ: Radio Amateur Callbook, 1993), p. 102, where it is shown with a reflector and referred to as a variation of the quad.

Updated 3-18-97 © L. B. Cebik, W4RNL Data may be used for personal purposes, but may not be reproduced for publication in print or any other medium without permission of the author.



[Go to Amateur Radio Page](#)



[Return to Home Page](#)

[Order this information in Print](#)
[Order this information on CD-ROM](#)
[Download in PDF Format](#)
[Click here to make tpub.com your Home Page](#)
Page Title: Broadside arrays
[Back](#) | [Up](#) | [Next](#)
[tpub.com Updates](#)

Web

www.tpub.com

[Home](#)
Information Categories
[Administration](#)
[Advancement](#)
[Aerographer](#)
[Automotive](#)
[Aviation](#)
[Combat](#)
[Construction](#)
[Diving **New**](#)
[Draftsman](#)
[Engineering](#)
[Electronics **New**](#)
[Food and Cooking **New**](#)
[Math](#)
[Medical](#)
[Music](#)
[Nuclear Fundamentals](#)
[Photography](#)
[Religion](#)
[USMC](#)
Products
[Back](#)
[Up](#)
[Next](#)

Directional arrays Content Moved End-Fire arrays

 [[Back](#)] [[Home](#)] [[Up](#)] [[Next](#)]

SPACING. - The lower relative efficiency of collinear arrays of many elements, compared with other multi-element arrays, relates directly to spacing and mutual impedance effects. Mutual impedance is an important factor to be considered when any two elements are parallel and are spaced so that considerable coupling is between them. There is very little mutual impedance between collinear sections. Where impedance does exist, it is caused by the coupling between the ends of adjacent elements. Placing the ends of elements close together is frequently necessary because of construction problems, especially where long lengths of wire are involved.

The effects of spacing and the advantages of proper spacing can be demonstrated by some practical examples. A collinear array consisting of two half-wave elements with 1/2-wavelength spacing between centers has a gain of 1.8 dB. If the ends of these same dipoles are separated so that the distance from center to center is 3/4 wavelengths and they are driven from the same source, the gain increases to approximately 2.9 dB.

A three-dipole array with negligible spacing between elements gives a gain of 3.3 dB. In other words, when two elements are used with wider spacing, the gain obtained is approximately equal to the gain obtainable from three elements with close spacing. The spacing of this array permits simpler construction, since only two dipoles are used. It also allows the antenna to occupy less space. Construction problems usually dictate small-array spacing.

Broadside Arrays

A broadside array is shown in figure 4-26, view A. Physically, it looks somewhat like a ladder. When the array and the elements in it are polarized horizontally, it looks like an upright ladder. When the array is polarized vertically, it looks like a ladder lying on one side (view B). View C is an illustration of the radiation pattern of a broadside array. Horizontally polarized arrays using more than two elements are not common. This is because the requirement that the bottom of the array be a significant distance above the earth presents construction problems. Compared with collinear arrays, broadside arrays tune sharply, but lose efficiency rapidly when not operated on the frequencies for which they are designed.

Figure 4-26. - Typical broadside array.

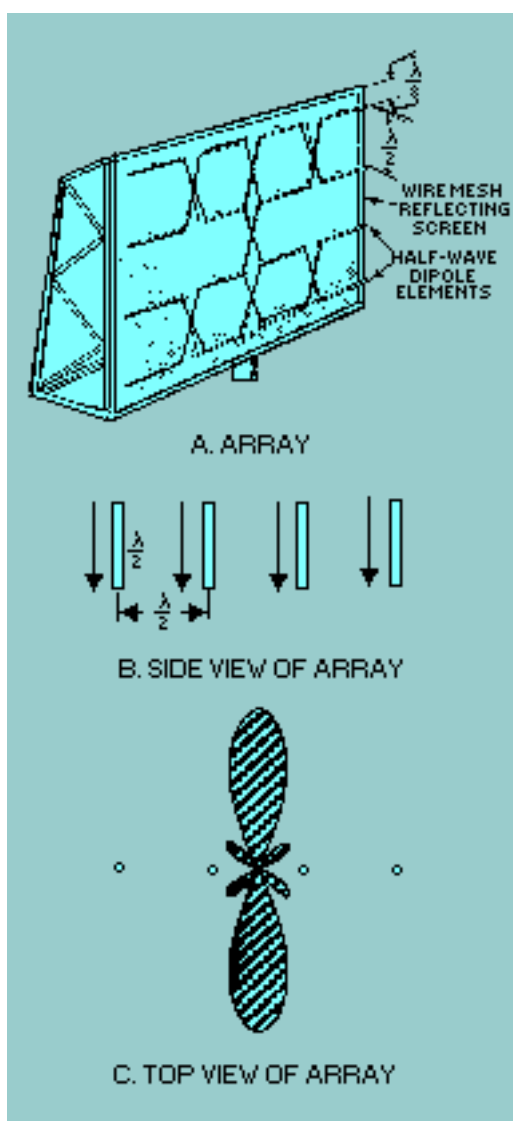

RADIATION PATTERN. - Figure 4-27 shows an end view of two parallel half-wave antennas (A and B) operating in the same phase and located $1/2$ wavelength apart. At a point (P) far removed from the antennas, the antennas

appear as a single point. Energy radiating toward P from antenna A starts out in phase with the energy radiating from antenna B in the same direction. Propagation from each antenna travels over the same distance to point P, arriving there in phase. The antennas reinforce each other in this direction, making a strong signal available at P. Field strength measured at P is greater than it would be if the total power supplied to both antennas had been fed to a single dipole. Radiation toward point P1 is built up in the same manner.

Figure 4-27. - Parallel elements in phase.

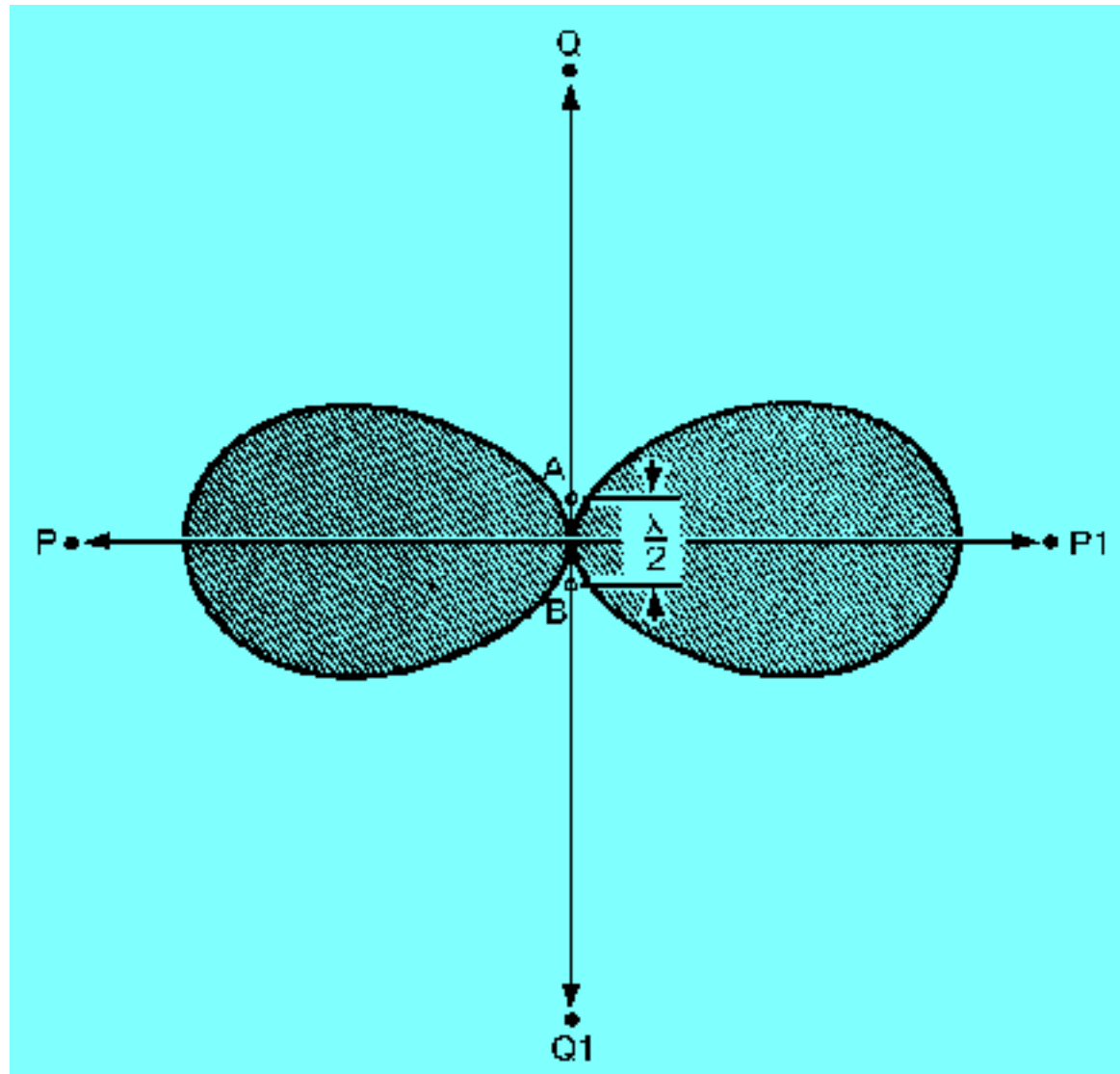

Next consider a wavefront traveling toward point Q from antenna B. By the time it reaches antenna A, $1/2$ wavelength away, $1/2$ cycle has elapsed. Therefore energy from antenna B meets the energy from antenna A 180 degrees out of phase. As a result, the energy moving toward point Q from the two sources cancels. In a like manner, radiation from antenna A traveling toward point Q1 meets and cancels the radiation in the same direction from antenna B. As a result, little propagation takes place in either direction along

the QQ1 axis. Most of the energy is concentrated in both directions along the PP1 axis. When both antenna elements are fed from the same source, the result is the basic broadside array.

When more than two elements are used in a broadside arrangement, they are all parallel and in the same plane, as shown in figure 4-26, view B. Current phase, indicated by the arrows, must be the same for all elements. The radiation pattern shown in figure 4-26, view C, is always bidirectional. This pattern is sharper than the one shown in figure 4-27 because of the additional two elements. Directivity and gain depend on the number of elements and the spacing between them.

GAIN AND DIRECTIVITY. - The physical disposition of dipoles operated broadside to each other allows for much greater coupling between them than can occur between collinear elements. Moving the parallel antenna elements closer together or farther apart affects the actual impedance of the entire array and the overall radiation resistance as well. As the spacing between broadside elements increases, the effect on the radiation pattern is a sharpening of the major lobes. When the array consists of only two dipoles spaced exactly $1/2$ wavelength apart, no minor lobes are generated at all. Increasing the distance between the elements beyond that point, however, tends to throw off the phase relationship between the original current in one element and the current induced in it by the other element. The result is that, although the major lobes are sharpened, minor lobes are introduced, even with two elements. These, however, are not large enough to be of concern.

If you add the same number of elements to both a broadside array and a collinear array, the gain of the broadside array will be greater. Reduced radiation resistance resulting from the efficient coupling between dipoles accounts for most of this gain. However, certain practical factors limit the number of elements that may be used. The construction problem increases with the number of elements, especially when they are polarized horizontally.

Q.32 What is the primary cause of broadside arrays losing efficiency when not operating at their designed frequency? **Answer**

Q.33 When more than two elements are used in a broadside array, how are the elements arranged? **Answer**

Q.34 As the spacing between elements in a broadside array increases, what is the effect on the major lobes? **Answer**

[[Back](#)] [[Home](#)] [[Up](#)] [[Next](#)]

[Order this information in Adobe PDF Printable Format](#)

Dinner at Red Lobster on us!

Hungry? Answer a few questions...

...get a **\$50 Restaurant Card**



[Privacy Statement](#) - [Press Release](#) - [Copyright Information.](#) - [Contact Us](#) - [Support Integrated Publishing](#)

RADIO HABANA CUBA

The Broomstick Special: Part 1 *A compact, easy-to-build shortwave antenna*

BY ARNIE CORO
Host of "Dxers Unlimited"

SEND YOUR COMMENTS, QUESTIONS AND IDEAS DIRECTLY TO ME AT:
arnie@radiohc.org

Yes, this is a "helically wound" wire antenna. It can be built in a few hours... it will take longer if you really want to make it look pretty... UGLY versions can be assembled in minutes. It MAY be used without an antenna tuner, BUT... it works best when you do USE a TUNER.

Here are the easy-to-follow, step-by-step building instructions for Arnie Coro's "Broomstick Special:"

1. Obtain a nice broomstick.... you can use a "classic" wooden dowel broomstick, or substitute heavy walled PVC plumbers plastic tubing
2. Diameter of broomstick is not critical; anything from about 1.5 centimeters or better will work (this means that PVC tubing of about 19mm or 3/4 inch is ideal)
3. Prepare a base to hold the broomstick or PVC pipe vertical... Use a wide base, with enough counterweight attached to keep the broomstick vertical (I use mine next to the bedside radio, have convinced the wife that it is "modern art")
4. Obtain an aluminium disk of no less than 15 cm (6 inches) diameter. I prefer using a disk of around 30 centimeters (12 inches) but this is not critical. **DO USE THE DISK...** as it provides a capacity hat termination and helps reduce NOISE PICK UP
5. Obtain enough No.16 PVC plastic covered household wire; this is the ideal choice, but if you can't find it, then you may use No.16 or No.18 enamel covered copper wire (the one used for winding motors and transformers). If you can't find No.16 PVC covered wire, then your second best choice is No.18 "speaker wire"
6. Connect one end of the wire to the aluminium disk, and start winding a uniform coil using the "broostick" as the coil form. **YOU WANT A NEAT JOB!** Turns should fit tightly one next to the other... the "broomstick" will be filled with the wire forming the coil... When you arrive at the bottom end, make a termination> I use a long bolt with

nuts and washers to which I tie the end of the wire, and another wire that goes to the antenna tuner. This wire that goes to the tuner can be from 1 meter to 3 meters long (from 3 to 10 feet) but **DO KEEP IT AS SHORT AS POSSIBLE.**

7. After the antenna is built, you may want to protect it with tightly wound PVC plastic tape over the wire. For **EXTRA** protection, you can paint the whole antenna with several coats of **SPRAY ENAMEL...**

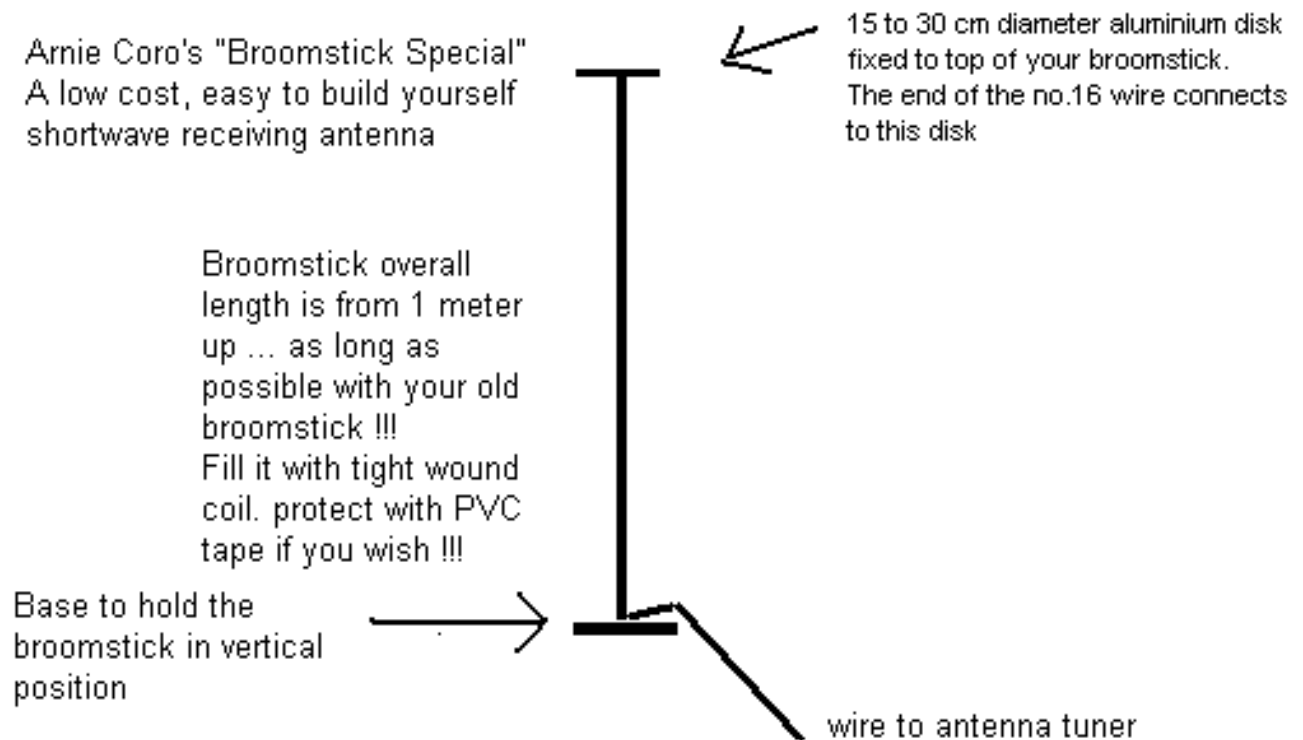

8. The antenna works best near a **WINDOW!!!** Or better yet, you can install it in your balcony or garden... **BUT DO KEEP THE CONNECTIONS TO THE TUNER SHORT**

9. The antenna is **RESONATED** with your antenna tuner.... **YOU MAY USE IT WITHOUT A TUNER** but results are not going to be as good as when the antenna is connected to the receiver via a well-designed antenna tuner

10. **YES... YOU MAY USE IT FOR TRANSMITTING.... BUT...** according to recent medical research information, keep it as far away as possible from your body!!!

11. The helically wound "broomstick" is a lot of fun to experiment with... It works best when you provide a ground connection to the antenna tuner - receiver combination. One way of providing an "artificial ground" is to connect a length of wire of no less than 5 meters as a "counterpoise," that meaning that you can let the wire hang around the room's floor or garden. Using the "broomstick" with resonant radials turns it into an excellent amateur radio antenna for a specific band... For example with 4 radials cut for

the 15 meter amateur band and a 4 feet high broomstick, (about 1.5 meters)

I can work a lot of stations on 21 mHz, something I do often to demonstrate to visitors what can be achieved with simple homebrew antennas, even when you don't have a lot of space.

12. QUESTIONS.... to: **arnie@radiohc.org**

13. FOR THE TECHNICALLY MINDED... [Click here for Part 2 of The Broomstick Antenna!](#)

Havana, Cuba
6 February, 1998

[Send e-mail to Arnie Coro](#)

[Back to RHC Homepage](#)



Welcome to the W3FF Home Page

Home of the homebrew "Buddipole" - A Portable Dipole Antenna Design

Sorry, your browser does not support Java



This site is for those hams who are seeking a high performance homebrew antenna for hf portable use. As you will see, I am particularly interested in pedestrian mobile operating. I started out in early 2000 with a Gap backpack, a TS-50, and a 7.5 amp-hour, six pound battery. Because I wanted to take my radio with me and communicate on HF, I designed a portable dipole antenna out of easily-found and low-cost materials. The Buddipole is the result of those efforts. This is a lightweight, modular, and rotatable dipole (a great benefit, by the way) and is very efficient on the higher bands. See the links below for information on how to build this popular antenna.

The original antenna design is still great. But there were problems with the PVC plastic pipe. It sags. The connectors become loose. The Radio Shack whips are flimsy, and they bend easily. So, the homebrew Buddipole project took on another level of sophistication. The result is a commercial antenna with the same name. You can find it here:

www.buddipole.com.

New materials, like epoxy composite and polypropylene, and 6061 aircraft aluminum, and Delrin. One set of higher-Q coils to work all the bands of the original version, plus 30m and 40m. Parts are custom-machined and we had new custom stainless steel whips manufactured to our specifications. We use stretch Velcro as a strain relief for the new coax rf bead assembly, and the assembly is encased in an adhesive shrinkwrap. Even the brass studs are drilled out to lighten them without sacrificing durability. We have a Delrin adaptor that takes painter's pole threads (Acme) to pipe threads that fit right into the new poly T's on the commercial product.

And now, we have the B.U.G. -- A Buddipole User's Group. You can sign up for this Yahoo Group on this page. A truly great resource to share many of the ideas, experiences, and suggestions for both the homebrew and commercial Buddipole.

Build the homebrew version on this site. Modify it. Tell us what you have worked with it on the air. We are always thrilled to hear from folks who build the antenna and who are active on the air with it! And consider upgrading to the new version, with the Rotatable Arms, that gives you a choice of six different configurations to play with.

Have fun and 73,

W3FF - Budd



Join the Buddipole User's Group!

Powered by groups.yahoo.com

This is a new internet based discussion group that began on July 19, 2002. It is an excellent resource for Buddipole users to share their thoughts, ideas, experiences, photos, and anything else that is Buddipole related. Drop by to see what everyone is talking about!



The W3FF Buddipole Antenna

[Read About it](#)

[Hear it](#)

[See it](#)

[Build the Buddipole](#)

[Buddipole FAQ Page](#)

[Dayton 2002 Recap](#)



Join the **W3FF Buddipole** email list

Email:

This is our email newsletter that we send to subscribers with tips, ideas, and suggestions for using the Buddipole. In addition, we will announce new products via this newsletter.



HOT Links to other AMATEUR Sites

[AC6V The Definitive Ham Page](#)

[The HFpack - The HF Portable Group](#)

[S.C.A.R.S. HOME PAGE \(Local Club \)](#)

[QRZ The Live-Wire Group - Ham experimental antennas, portable operations](#)

Amateur Radio RF Safety, Are you in compliance?

QRZ callsign lookup:

Callsign lookups provided by qrz.com



Send Page To a Friend



E-Mail W3FF



Index of /w2blc

| Name | Last modified | Size | Description |
|----------------------|-------------------------------|----------------------|-----------------------------|
|----------------------|-------------------------------|----------------------|-----------------------------|



| | | | |
|----------------------------------|-------------------|---|--|
| Parent Directory | 06-Sep-2004 13:05 | - | |
|----------------------------------|-------------------|---|--|

Apache/1.3.22 Server at www.qsl.net Port 80

[Search](#)
[Index](#)
[Learn](#)
[Specials](#)
[Buy](#)
[Support](#)
Free!
Local Seminars Now Offered!

Structured Wire, Whole House Audio & Automated Lighting Control



Coaxial Bulk Cable

Generic Coaxial Cable

RG6 Quad Shield

Name Brand RG-6/U Coax

Belden RG6 Quad Shield

Belden RG6 Dual Shield

Belden RG6 Dual Shield Siamese

Monster RG6 Quad Shield

Monster RG6 ISAT Reference

RG-59/U Coaxial Cable

Camera Coax (coax + power)

Five RG59 Coax Bundle

Miniature Coaxial Cable

Miniature Coaxial Cable

Miniature 3 & 5 Coax Bundle

Cable Bundles

Two RG-6U (Siamese)

Five RG-59/U

Two RG-6/U Quad + Two Cat 5e

Two RG-6/U Quad + Two Cat 5e +

Two Fiber

Three or Five Miniature Coax

Related Links

Techwire Index

RF (Coax) Patch Cables

RF (Coax) Connectors

Combination Cable

Coax Splitters

Coax Strippers & Crimpers

Coax Attenuators, Filters, DC Blockers, & Terminators.

| <i>QuickLink</i> | Patch | Bulk | Connectors Adaptors | Tools |
|-------------------|------------------------|------------------------|------------------------|------------------------|
| Audio | Click! | Click! | Click! | |
| Video/RF | Click! | Click! | Click! | Click! |
| Phone/Data | Click! | Click! | Click! | Click! |

Generic RG-6/U Coaxial Cable



HomeTech Solutions

RG6Q

RG-6/U Quad Shield Coaxial Cable



- Use RG-6/U Quad Shield for high quality or complex installations and where local over-the-air signals may cause interference.
- Available by the foot and in 1000' spool or box.
- Swept to 2200 Mhz.
- 18 AWG Copper coated steel center conductor.
- Running "FT" count printed on cable makes measuring easy.
- Type CL2. (In-wall rated.) UL Listed.
- **Note:** shipping charges for bulk wire and cable are actual cost.

| | | | | | |
|------------------|--|----------------------|---|--------------|-------------|
| Earn TechCash | HT-RG6QB RG6 Quad Shield Cable, Black CMR | List 0.26 foot | \$0.22 foot | Enter Qty | IN STOCK |
| | | | | foot | |
| Earn TechCash | HT-RG6QB RG6 Quad Shield Cable, Black CMR | | 33 lbs/spool/1000ft \$109.00 spool/1000ft | Enter Qty | IN STOCK |
| | | | | spool/1000ft | |



[Index](#) [Learn](#) [Specials](#) [Buy](#) [Support](#)

Search

Free!

Local Seminars Now Offered!

Structured Wire, Whole House Audio & Automated Lighting Control



Name Brand RG-6/U Coaxial Cable



Belden

Authorized Belden
Reseller

1189A

RG-6/U Quad Shield Coaxial Cable

- Use RG-6/U Quad Shield for high quality or complex installations and where local over-the-air signals may cause interference.
- Available by the foot and in 1000' spool or box.
- Swept to 1 Ghz.
- 18 AWG Copper coated steel center conductor.
- Running "FT" count printed on cable makes measuring easy.
- Type CL2. (In-wall rated.) UL Listed.
- Available in black and white.
- Full Specifications (GIF)
- **Note:** shipping charges for bulk wire and cable are actual cost.



| | | | | | |
|----------------------|--|----------------------|---|-----------|--------------|
| Earn TechCash | BE-1189A COAX RG-6/U Quad Shield NEC CATV CL2 | List 0.32 foot | \$0.26 foot | Enter Qty | IN STOCK |
| Earn TechCash | BE-1189A COAX RG-6/U Quad Shield NEC CATV CL2 | | 36 lbs/spool/1000ft \$129.00 spool/1000ft | Enter Qty | IN STOCK |
| Earn TechCash | BE-1189AW COAX RG-6/U Quad - White NEC CATV CL2 | List 0.32 foot | \$0.26 foot | Enter Qty | LOW STOCK |
| Earn TechCash | BE-1189AW COAX RG-6/U Quad - White NEC CATV CL2 | | 36 lbs/spool/1000 \$129.00 spool/1000 | Enter Qty | LOW STOCK |



Belden

**Authorized Belden
Reseller**

9116

RG-6/U Dual Shield Coaxial Cable

- Use RG-6/U Dual Shield for general purpose video cable for distribution of broadcast and cable TV throughout your home.
- Available by the foot and in 1000' spool or box.
- [Full Specifications](#) (GIF)
- **Note:** shipping charges for bulk wire and cable are actual cost.



| | | | | | |
|------------------|--|----------------------|--|--------------|-------------|
| Earn TechCash | BE-9116 COAX RG-6/U Dual Shield NEC CATV CL2 Black | List 0.22 foot | \$0.18 foot | Enter Qty | IN STOCK |
| | | | | foot | |
| Earn TechCash | BE-9116 COAX RG-6/U Dual Shield NEC CATV CL2 Black | | 30 lbs/spool/1000ft \$87.90 spool/1000ft | Enter Qty | IN STOCK |
| | | | | spool/1000ft | |



Belden

**Authorized Belden
Reseller**

9077

**RG-6/U Dual Shield Siamese
Coaxial Cable**

- Use RG-6/U Siamese Dual Shield for general purpose video cable for distribution of broadcast and cable TV throughout your home whenever you need to run two cables at a time.
- Perfect for dual LNB satellite dish installations!
- Available by the foot and in 1000' spool.
- Full Specifications (GIF)
- **Note:** shipping charges for bulk wire and cable are actual cost.

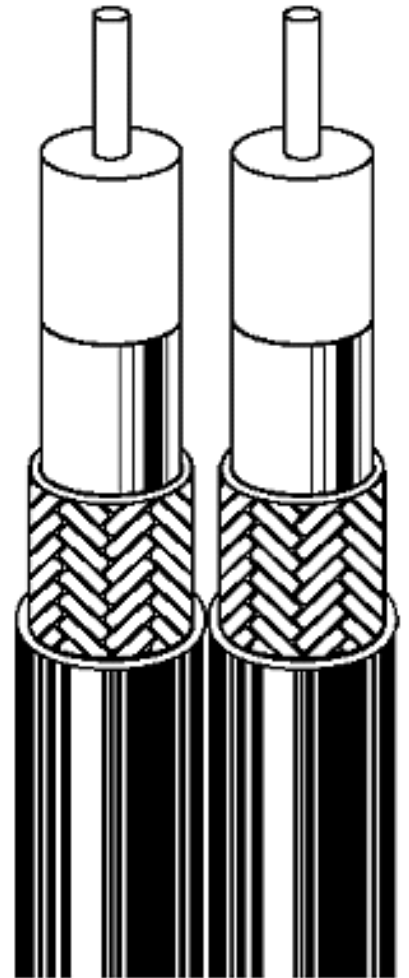

| | | | | | |
|------------------|---|----------------------|---|--------------|-------------|
| Earn TechCash | BE-9077 RG6, Siamese, Dual Shield NEC CATV CL2 | List 0.54 foot | \$0.45 foot | Enter Qty | IN STOCK |
| | | | | foot | |
| Earn TechCash | BE-9077 RG6, Siamese, Dual Shield NEC CATV CL2 | | 66 lbs/spool/1000ft \$219.00 spool/1000ft | Enter Qty | IN STOCK |
| | | | | spool/1000ft | |

MONSTER CABLE

MVQ

RG-6/U Quad-Shield Coaxial Cable

- Designed for high quality transmission with minimal interference.
- Quad shield minimizes both air interference and low level AC.
- Thin copper strands allow for one of the most flexible Quad Shielded coax cables on the market.
- Powder coated outer coat for smooth surface and easy runs.
- Available by the foot and in a 500' spool.
- **Note:** shipping charges for bulk wire and cable are actual cost.



| | | | | | |
|------------------|-----------------------------------|----------------------|---|-------------|-------------------------|
| Earn TechCash | MC-MVQ RG-6 Quad Shield | List 0.80 foot | \$0.77 foot | Enter Qty | TEMP OUT OF STOCK |
| | | | | foot | |
| Earn TechCash | MC-MVQ RG-6 Quad Shield | | 30 lbs/spool/500ft \$219.95 spool/500ft | Enter Qty | TEMP OUT OF STOCK |
| | | | | spool/500ft | |

MONSTER CABLE

ISATR

RG-6/U ISAT Reference Coaxial Cable

- Satellite tuned.
- UV resistant.
- Direct burial rated.
- Available by the foot and in 1000' spool.
- **Note:** shipping charges for bulk wire and cable are actual cost.



| | | | | | |
|--|--|----------------------|---|------------------------------|----------|
|  | MC-ISATR Monster Satellite ISAT REF 75 ohm High Resolution Coax | List 1.30 foot | \$1.22 foot | Enter Qty foot | IN STOCK |
| | MC-ISATR Monster Satellite ISAT REF 75 ohm High Resolution Coax | | 20 lbs/spool/500ft \$344.95 spool/500ft | Enter Qty spool/500ft | IN STOCK |



Index
Learn
Specials
Buy
Support

Search

Free!

Local Seminars Now Offered!
 Structured Wire, Whole House Audio & Automated Lighting Control

@

RG-59/U Coaxial Cable

98132

CCTV Camera Cable
1 RG/59U + 2 18AWG Power
Wires

- One RG-59 single-shield 75ohm coaxial cable.
- Two 18 gauge stranded wires.
- In a PVC Class 2 rated jacket.
- Perfect for wiring video cameras: Use the RG59 for the video feed and the red and black wires for power to the camera.
- Available by the foot and in 500' spool.
- **Note:** shipping charges for bulk wire and cable are actual cost.



| | | | | | |
|--|---|----------------------|--|------------------------------|-------------|
|  | AW-98132 RG59 and 18/2 CCTV Cable | List 0.72 foot | \$0.69 foot | Enter Qty foot | IN STOCK |
| | AW-98132 RG59 and 18/2 CCTV Cable | | <u>37 lbs/spool/500ft</u> \$189.95 spool/500ft | Enter Qty spool/500ft | IN STOCK |



Belden

**Authorized Belden
Reseller**

7796A

Five RG-59/U Cable Bundle (HDTV Bulk Cable)

- Belden Quality
- 5 RG59 Cables
- Color coded for easy Identification
- Low-Friction Jacket and filler for consistant shape.
- Easy runs.

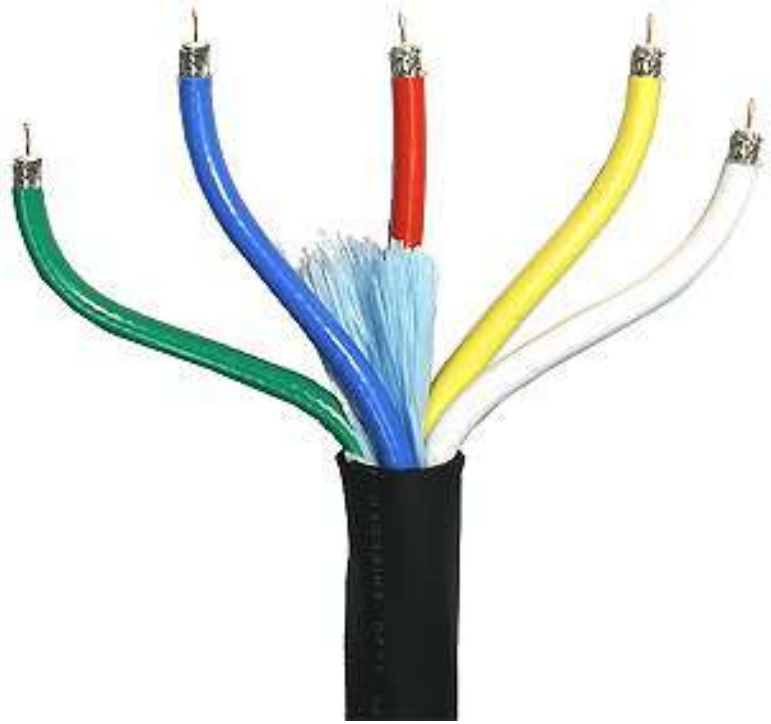

This cable can be terminated to BNC male connectors in a two step process. First, strip the coax ends using an [IT1000 Stripping/Compression Tool](#) (or similar). Use the [SNS59](#) connectors (along with the IT1000 tool) to terminate the ends. After the ends have been properly terminated, attach the [BNC to F-Connector Adapters](#) to each end. See [Online Tutorial](#) on terminating coaxial cables using the Snap N' Seal connectors.

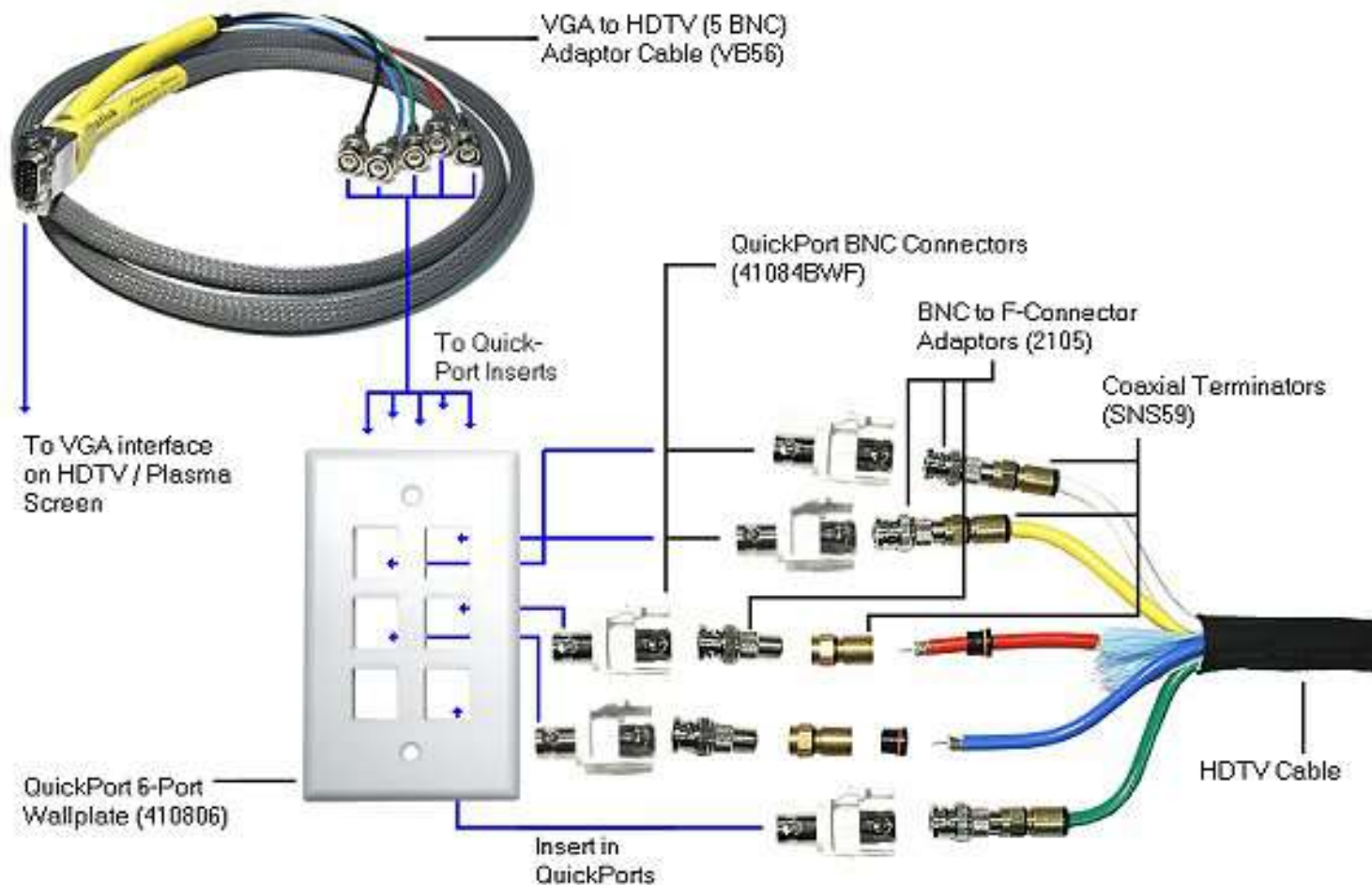

You can use the Leviton QuickPort wallplate and the Barrel BNC QuickPort Inserts to professionally the in-wall cable and adaptors.

If your screen has only a 15-pin VGA interface, you need to purchase a UXGA to HDTV (5 BNC) Cable Interconnect. Otherwise, you can connect using BNC Patch Cables.

| | | | | | |
|------------------|--|----------------------|---|-------------|-------------|
| Earn TechCash | BE-7796A Bundled RG59 x 5 HDTV Cable | List 4.00 foot | 0.3 lbs/foot \$3.35 foot | Enter Qty | IN STOCK |
| | | | | foot | |
| Earn TechCash | BE-7796A Bundled RG59 x 5 HDTV Cable | | 150 lbs/spool/500ft \$1415.00 spool/500ft | Enter Qty | IN STOCK |
| | | | | spool/500ft | |

[Index](#)

[Learn](#)

[Specials](#)

[Buy](#)

[Support](#)



Search

Free!

Local Seminars Now Offered!

Structured Wire, Whole House Audio & Automated Lighting Control



Miniature Coaxial Cable



Belden

**Authorized Belden
Reseller**

1855A

Brilliance Miniature Dual-Shield Coaxial Cable

- 75 ohm coaxial cable
- 23 AWG solid bare copper center conductor
- Dual shield
- Black suitable for indoor and outdoor aerial applications. All other colors suitable for indoor use only.
- Full Specifications (GIF)
- Connectors available: "F", RCA, & BNC
- Use our 200004 stripper and 300007 crimper.



Only .16" (< 3/16") in diameter!

An excellent coaxial cable for running baseband video (one cable required), s-video (two cables required), component video (three cables required), or UXGA video (five cables required). Also works great for line-level audio and subwoofer audio. The small size of this cable makes it easy to route and hide. The low loss makes long runs >300ft possible. **Not suitable for raw satellite, UHF/VHF, or CATV signals.**

| | | | | | | |
|----------------------|---|----------------------|--|--|-----------|----------|
| Earn TechCash | BE-1855AE Miniature Coax Cable, Black Brilliance VideoFLEX | List 0.42 foot | \$0.35 foot | | Enter Qty | IN STOCK |
| Earn TechCash | BE-1855AE Miniature Coax Cable, Black Brilliance VideoFLEX | | <u>18 lbs/spool/1000ft</u> \$299.00 spool/1000ft | | Enter Qty | IN STOCK |
| Earn TechCash | BE-1855AR Miniature Coax Cable, Red Brilliance VideoFLEX | List 0.42 foot | \$0.35 foot | | Enter Qty | IN STOCK |
| Earn TechCash | BE-1855AR Miniature Coax Cable, Red Brilliance VideoFLEX | | <u>18 lbs/spool/1000ft</u> \$299.00 spool/1000ft | | Enter Qty | IN STOCK |
| Earn TechCash | BE-1855AG Miniature Coax Cable, Green Brilliance VideoFLEX | List 0.42 foot | \$0.35 foot | | Enter Qty | IN STOCK |
| Earn TechCash | BE-1855AG Miniature Coax Cable, Green Brilliance VideoFLEX | | <u>18 lbs/spool/1000ft</u> \$299.00 spool/1000ft | | Enter Qty | IN STOCK |
| Earn TechCash | BE-1855AL Miniature Coax Cable, Blue Brilliance VideoFLEX | List 0.42 foot | \$0.35 foot | | Enter Qty | IN STOCK |
| Earn TechCash | BE-1855AL Miniature Coax Cable, Blue Brilliance VideoFLEX | | <u>18 lbs/spool/1000ft</u> \$299.00 spool/1000ft | | Enter Qty | IN STOCK |
| Earn TechCash | BE-1855AY Miniature Coax Cable, Yellow Brilliance VideoFLEX | List 0.42 foot | \$0.35 foot | | Enter Qty | IN STOCK |
| Earn TechCash | BE-1855AY Miniature Coax Cable, Yellow Brilliance VideoFLEX | | <u>18 lbs/spool/1000ft</u> \$299.00 spool/1000ft | | Enter Qty | IN STOCK |

| | | | | | |
|------------------|---|----------------------|--|--------------|-------------|
| Earn TechCash | BE-1855AW Miniature Coax Cable, White Brilliance VideoFLEX | List 0.42 foot | \$0.35 foot | Enter Qty | IN STOCK |
| | | | | foot | |
| Earn TechCash | BE-1855AW Miniature Coax Cable, White Brilliance VideoFLEX | | <u>18 lbs/spool/1000ft</u> \$299.00 spool/1000ft | Enter Qty | IN STOCK |
| | | | | spool/1000ft | |



Belden

Authorized Belden
Reseller

7787A

7789A

Brilliance Miniature Dual-Shield Coaxial Cable Bundles

- Bundle of 3 or 5 "1855A" type coaxial cables (see above).
- Outside diameter only .44" (7787A) or .54" (7789A)
- 23 AWG solid bare copper center conductors
- Dual shield
- Suitable for indoor and outdoor aerial applications.
- UL/NEC CMR, CEC C(UL) CMG. Flame Resistance: UL 1666 Riser, CSA FT4.
- Full Specifications (GIF)
- Connectors available: "F", RCA, & BNC
- Use our 200004 stripper and 300007 crimper.



7787A



7789A

An excellent coaxial cable bundle for running baseband video, s-video, component video, or UXGA video. Also works great for line-level audio and subwoofer audio. The small size of this cable bundle makes it easy to route and hide. The low loss makes long runs > 300ft possible. **Not suitable for raw satellite, UHF/VHF, or CATV signals.**

| | | | | | |
|------------------|--|----------------------|---|------------------------------|-------------|
| Earn TechCash | BE-7787A Miniature Coax,Bundle/3,Black Brilliance VideoFLEX | List 2.06 foot | \$1.70 foot | Enter Qty foot | IN STOCK |
| | BE-7787A Miniature Coax,Bundle/3,Black Brilliance VideoFLEX | | <u>47 lbs/spool/500ft</u> \$770.00 spool/500ft | Enter Qty spool/500ft | IN STOCK |
| Earn TechCash | BE-7789A Miniature Coax,Bundle/5,Black Brilliance VideoFLEX | List 2.99 foot | \$2.47 foot | Enter Qty foot | IN STOCK |
| | BE-7789A Miniature Coax,Bundle/5,Black Brilliance VideoFLEX | | <u>73 lbs/spool/500ft</u> \$1055.00 spool/500ft | Enter Qty spool/500ft | IN STOCK |

| | | | | | |
|--|------------------------|--|--------------------------|---------------------|-------------------------|
|  | Index | Learn | Specials | Buy | Support |
| | Search | Free! Local Seminars Now Offered! @ Structured Wire, Whole House Audio & Automated Lighting Control | | | |

[Home](#) | [Index](#) | [Learn More](#) | [Specials](#) | [How To Buy](#) | [Resale Info](#) | [Advanced Search](#) | [Employment](#)

| | | |
|---|---|--|
|  | Click here to view your TechCart | |
| | Click here when finished shopping | |

| | | |
|---|---|--|
| Orders: (888) 257-4406 | HomeTech Solutions MAP DIRECTIONS HOURS | Phone: (408) 257-4406 Fax: (408) 257-4389 <u>Other Contact Info</u> |
|---|---|--|



Copyright © 1992-2004 HomeTech Solutions. All Rights Reserved.

Coax Monopole Antenna

by OE1MWW
Feb. 2002

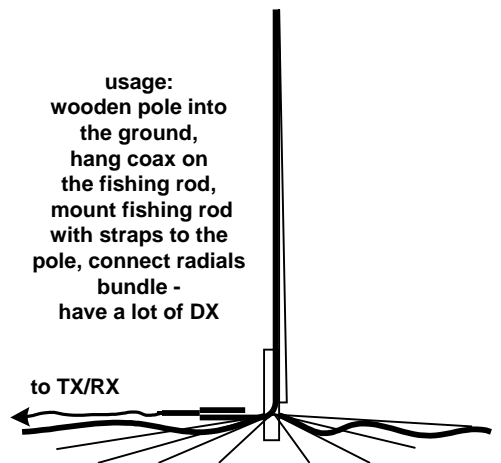
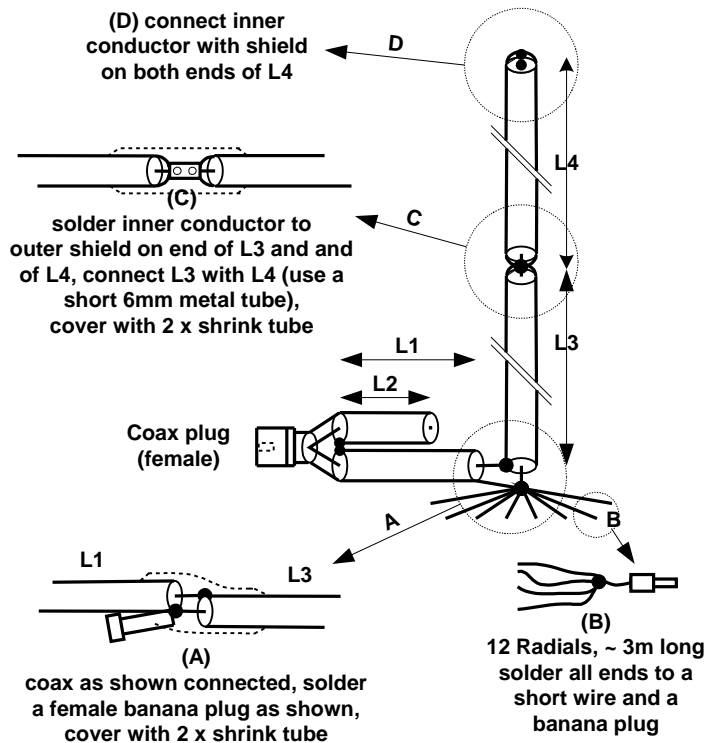

Feedpoint impedance of antenna is ~ 36 Ohms
YES, it's right, the inner conductor of L1 (feeding coax) is connected to the shield of L3 ! The radiating part of this antenna is the outside shield of L3 and L4.

L1,L2,L3,L3 is made of Coax RG/58 or RG/213

L1 & L2: use the software "coaxstub.exe" to calculate.
<http://www.qsl.net/oe1mww/coaxstub.exe>
you need VB6 runtime!

This document can be found at http://www.qsl.net/oe1mww/coax_monopole.pdf

$L3 = f/4 * V_k$
 $L4 = (f/4 * 0,95) - L3$,
tune L4 for best SWR,
important: inner conductor is connected to shield of L4 on both ends! instead of coax, you can use also a thick wire for L4.

f in meters of wavelength
Vk of coax is ~ 0,66 (RG58U)

[Order this information in Print](#)

[Order this information on CD-ROM](#)

[Download in PDF Format](#)

[Click here to make tpub.com your Home Page](#)

Page Title: Directional arrays

[Back](#) | [Up](#) | [Next](#)

[tpub.com Updates](#)



Web

www.tpub.com

[Home](#)

Information Categories

[Administration](#)

[Advancement](#)

[Aerographer](#)

[Automotive](#)

[Aviation](#)

[Combat](#)

[Construction](#)

[Diving **New**](#)

[Draftsman](#)

[Engineering](#)

[Electronics **New**](#)

[Food and Cooking **New**](#)

[Math](#)

[Medical](#)

[Music](#)

[Nuclear Fundamentals](#)

[Photography](#)

[Religion](#)

[USMC](#)

Products

[Back](#)

[Up](#)

[Next](#)

Array antennas Content Moved Broadside arrays

[[Back](#)] [[Home](#)] [[Up](#)] [[Next](#)]

DIRECTIONAL ARRAYS

You have already learned about radiation patterns and directivity of radiation. These topics are important to you because using an antenna with an improper radiation pattern or with the wrong directivity will decrease the overall performance of the system. In the following paragraphs, we discuss in more detail the various types of directional antenna arrays mentioned briefly in the "definition of terms" paragraph above.

Collinear Array

The pattern radiated by the collinear array is similar to that produced by a single dipole. The addition of the second radiator, however, tends to intensify the pattern. Compare the radiation pattern of the dipole (view A of figure 4-25) and the two-element antenna in view B. You will see that each pattern consists of two major lobes in opposite directions along the same axis, QQ1. There is little or no radiation along the PP1 axis. QQ1 represents the line of maximum propagation. You can see that radiation is stronger with an added element. The pattern in view B is sharper, or more directive, than that in view A. This means that the gain along the line of maximum energy propagation is increased and the beam width is decreased. As more elements are added, the effect is heightened, as shown in view C. Unimportant minor lobes are generated as more elements are added.

Figure 4-25. - Single half-wave antenna versus two half-wave antennas in

phase.

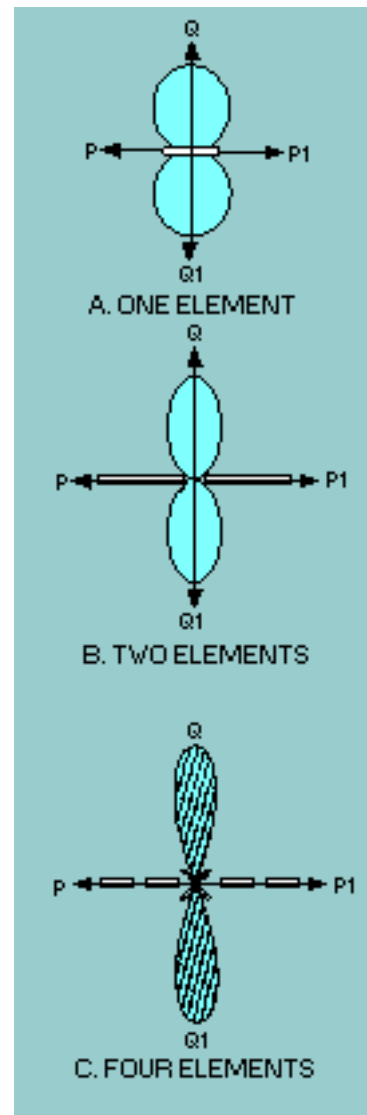

More than four elements are seldom used because accumulated losses cause the elements farther from the point of feeding to have less current than the nearer ones. This introduces an unbalanced condition in the system and impairs its efficiency. Space limitations often are another reason for restricting the number of elements. Since this type of array is in a single line, rather than in a vertically stacked arrangement, the use of too many elements results in an antenna several wavelengths long.

RADIATION PATTERN. - The characteristic radiation pattern of a given array is obtained at the frequency or band of frequencies at which the system is resonant. The gain and directivity characteristics are lost when the antenna is not used at or near this frequency and the array tunes too sharply. A collinear antenna is more effective than an end-fire array when used off its tuned frequency. This feature is considered when transmission or reception is to be over a wide frequency band. When more

than two elements are used, this advantage largely disappears.

LENGTH AND PHASING. - Although the $1/2$ wavelength is the basis for the collinear element, you will find that greater lengths are often used. Effective arrays of this type have been constructed in which the elements are 0.7 and even 0.8 wavelength long. This type of array provides efficient operation at more than one frequency or over a wider frequency range. Whatever length is decided upon, all of the elements in a particular array should closely adhere to that length. If elements of different lengths are combined, current phasing and distribution are changed, throwing the system out of balance and seriously affecting the radiation pattern.

Q.28 What is the maximum number of elements ordinarily used in a collinear array? **Answer**

Q.29 Why is the number of elements used in a collinear array limited? **Answer**

Q.30 How can the frequency range of a collinear array be increased? **Answer**

Q.31 How is directivity of a collinear array affected when the number of elements is increased? **Answer**

[[Back](#)] [[Home](#)] [[Up](#)] [[Next](#)]

[Order this information in Adobe PDF Printable Format](#)

Please select your favorite fruit and get a surprise!



[Privacy Statement](#) - [Press Release](#) - [Copyright Information.](#) - [Contact Us](#) - [Support Integrated Publishing](#)

Corner reflector antenna

Do you need a high gain antenna? Have you suffered on picking up interference from unwanted direction? You need a directional antenna but a 12 element Yagi will be too attractive! Well, following might be the answer - a corner antenna. It can provide a forward gain of about 12dbi with a front to back ratio of well over 20dbi.

This design is a periodic plane spaced behind a radiating dipole. The critical factors are the corner angle and the spacing between dipole/vertex (fold point of reflector). The curves in fig.A show that as angle is reduced, the gain becomes progressively greater.

FIG-A RELATIONSHIP BETWEEN ANGLE/SPACING/GAIN

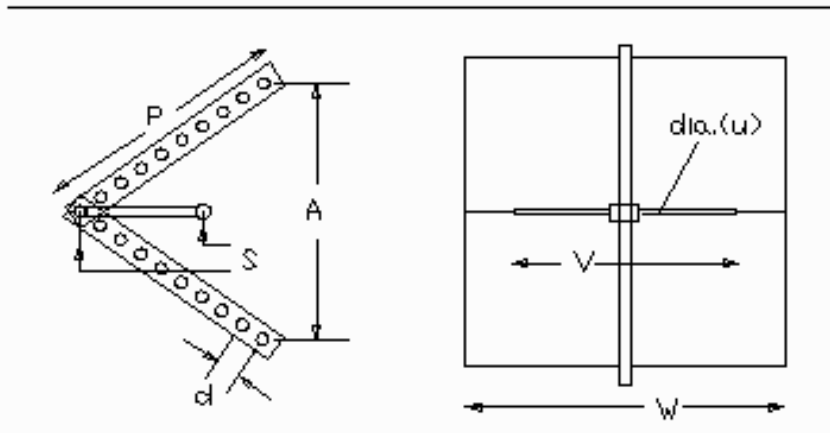
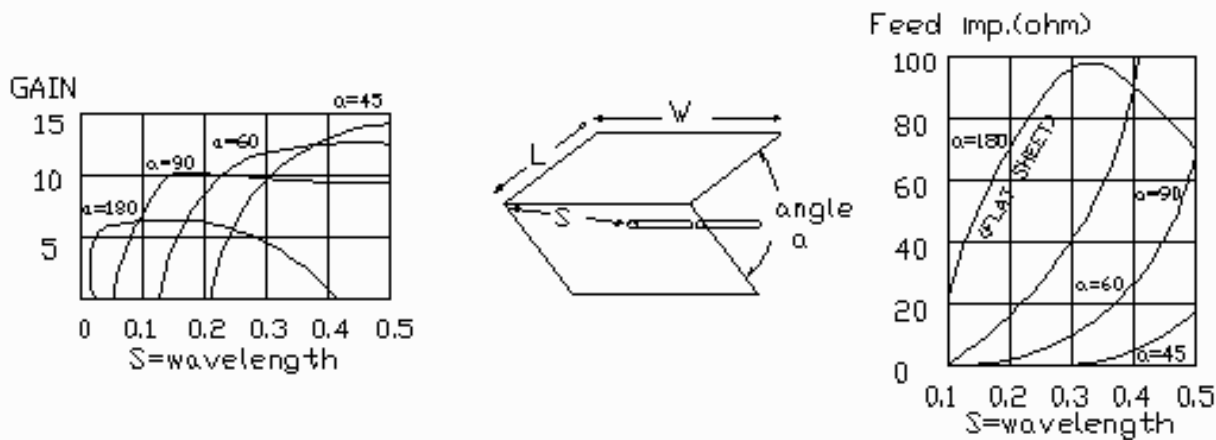

Fig.B
Dimensions for
a 60 degree
reflector antenna

At the same time the feed impedance of the antenna falls towards a lower value and starts creating difficulty in matching. In practice this angle is usually at 90 degree or 60 degree while 90 degree is easier to be matched although gain is lower.

Following are some key points when designing such antenna :

- Length (L) of the sides of reflector should exceed 2x wave-length to secure the characteristics. Reflector width W should be greater then 1x wave-length for a half-wave radiator.
- The reflector can be made of wire netting, sheet metal or even fabricated metal spines arranged in a V-formation. Such spines must be parallel to the radiator with a spine spacing of less then 0.1 wave-length of the operating frequency.
- Spacing between radiator and vertex should be adjustable. This might be the final key to tune-up such an antenna after radiator length is settled for a specific operating frequency.

Impedance of these antennas will change upon operating frequency. Typical value will be around 50 ohm to 75 ohm. A slightly higher S.W.R (1.7:1) has to be expected on lower end of the band. Fig.A also shows relationship between resultant impedance and a change in wavelength (frequency). Following is a table that shows the general dimension of such antenna at UHF and VHF band (Fig.B). All value below are in inches (except **Band** in MHz). Final dimension might vary due to difference in materials employed. Try by error is the key for success.

| Band | p | s | d | v | w | A | u |
|-------------|----------|----------|----------|----------|----------|----------|----------|
| 144 | 100 | 40.0 | 6 | 38 | 50 | 100 | 0.375 |
| 440 | 34 | 13.0 | 1.4 | 13 | 20 | 34 | 0.25 |
| 435 | 35 | 13.5 | 1.5 | 13 | 20 | 35 | 0.25 |

We can discuss it further on the air if you are interested.

By VE3RGW Sept 96.

[Return to Dreamland](#)

THE CROSSED-FIELD-ANTENNA PART I

by

Maurice C. Hatley GM3HAT
& Ted Hart W5QJR

PREFACE: Please be aware this article introduces a completely new concept in antenna theory. In fact, this is considered the most important development relative to antennas in this century. It is so pervasive that a series of articles are required to cover the concept and its applications to the depth and extent it deserves. This is the first publication about the **Crossed-Field Antenna** (CFA) in the U.S.A. Even as you read this, there are continuing developments in the application of this concept. **antennex**

has more than twenty articles about the CFA, including four construction articles (complemented by several more building experiments by readers from around the globe), plus a look at the actual CFA 1992 and 1995 versions of Tanta Station operated in Egypt. This is followed up by a tour of 10 of Dr. Kabbary's 17 more recent CFA broadcast stations in operation in Egypt and Australia. Further, of interest is that the Isle of Man, UK has chosen to install a CFA longwave broadcast station rather than a 845-foot (260m) tower. More stations are going up in Germany, Italy and Brazil. The articles are in the Reading Rooms now. To read more, goto: [Subscribe](#)

Where will this concept lead ? Let me tell you about one example, lest you think this is all for naught: A CFA only 21 feet (6.5 Meters) tall, located at Tanta in the center of Egypt, provides AM broadcast service at 1.16 MHz (258 Meters) to millions of people from Cairo north to the coast. Certified measurements provide evidence that this small CFA produces a radiated signal almost 6 dB stronger than the previous 1/4 wavelength vertical broadcast tower which was 211 feet (65 Meters) tall. To express the performance a different way >> with the tall tower, a 100,000 watt transmitter was required for the desired coverage. With the miniature CFA the same coverage was attained with the transmitter power reduced to 30,000 watts.

BANDWIDTH GREATER THAN TALL TOWER!

Unlike conventional small antennas, the CFA has greater bandwidth than the tall tower, thus giving better fidelity to the broadcast signal. If that don't tug your heartstrings, you need to go back to making mud pies. For all the rest—you ain't seen nothing yet. In spite of this, the



antenna "experts" have not widely accepted this concept. I can only conclude that those who did not invent it don't want to admit that someone else did. That is a common malady and is often referred to as the not-invented-here (NIH) syndrome. I personally went through the same thing with the small loop antenna. It is the purpose of **antenneX** to expose you to new concepts—whether you accept them or not is your personal preference. Some people still don't think man has set foot on the moon!

INTRODUCTION

While thinking about how to present this article, I (W5QJR) was scanning the web and found the following definition of an antenna: "**An antenna can be any conductive structure that can carry an electrical current. If it carries a time varying electrical current, it will radiate an electromagnetic wave.**" In particular note that this definition of an antenna includes a **current carrying conductor**. This is a concept that came about after Marconi threw up a piece of wire and began radio communications. Ever since it has been the accepted traditional concept of an antenna. While it does satisfy fundamental theorem, it is not the only way to develop electromagnetic waves, and therefore is not the only way to build an antenna. In fact, this is a very inefficient way to develop electromagnetic waves.

A number of years ago (1984) I (Ted Hart) wrote the book on small loop antennas and declared in that book, and several related articles, that the only way to build a small high efficiency antenna was to build a small loop. That statement was true until about 1988.

I am simply telling you that one doesn't have to have a wire antenna—there is another way. The other way came about due to a College Professor by the name of **Maurice Hately, GM3HAT**, in Scotland, and a student named **Fathi Kabbary** who came from Egypt to study under Professor Hately while working on his Ph.D. Together, they reviewed the fundamental theory of antennas and decided there was a better way. This occurred about 1988. Subsequently they published articles and patented their new antenna design. Patent 2,215,524 was issued in Great Britain, 626,210 in Australia and others issued in Europe and Japan. In 1992 the U.S. issued Patent Number 5,155,495. But, I am getting ahead of history, so let me take you back to an earlier time.

However, before giving you a history lesson, I do want to note that Mr. Hately and Mr. Kabbary jointly own all rights to this invention. All rights are reserved by them. If you have a commercial interest, contact the author. Mr. Hately reviewed, modified and approved this article, so you are getting this information from the horse's mouth. I, W5QJR, am merely a ghostwriter and take no credit for any of the development. I have derived great pleasure in working with Mr. Hately for several years and he is now in the process of bringing antennas based on this concept for sale thru **antenneX**.

A HISTORY LESSON

A long time ago, in a far away place, a fellow named Ampere and another fellow named

Faraday (1791-1867) independently developed the concepts and equations to define electromagnetism. Then along came a fellow by the name of Maxwell (1831-1879) who combined the works of Ampere and Faraday and developed the four (4) basic laws called **Maxwell's Equations**. These equations are so fundamental that every Engineer considers them to be **the** four chapters of the engineering bible. Then along came Mr. Heavyside who developed the Differential form of Maxwell's Equations. Somewhere in there, Mr. Poynting presented his equation defining electromagnetic radiation.

Although many authors have quoted Maxwell, and many a college student has struggled trying to understand Maxwell, nothing interesting happened until along came Professor Hatley and Mr. Kabbary (now Dr. Kabbary due to this work). As is prudent to do when trying to understand a concept, you go to the most fundamental version of the concept that can be found. In this case, Maxwell's Equations were only an arm's reach away in any good engineering reference book (for example see page 45-4 of **Reference Data for Radio Engineers**).

Now, our time clock moves forward to March 1989, when **Electronics and Wireless World** published an article entitled "Maxwell's Equations and the Crossed-Field Antenna", by F.M. Kabbary, M.C. Hatley and B.G. Stewart. To ensure you get all of this picture in proper perspective, the following paraphrases that article. It may get a little technical for some, but that is the essence of this new antenna concept. We will endeavor to translate to simple terms wherever possible, so please continue to read even if you are not an engineer. The picture would not be complete if the theoretical portion of this puzzle was not included in this series of articles.

A LOT OF HEAVY THEORY

All electrical and communications engineers are in some way acquainted with Heavyside's differential form of the third and fourth Maxwell equations, viz.

$$1) \Delta \times \mathbf{E} = -\mathbf{B}'$$

$$2) \Delta \times \mathbf{H} = \mathbf{J} + \mathbf{D}'$$

In these equations, ' is the derivative with respect to time, **E** represents the electric field strength, **H** magnetic field strength, **J** current density, **B** magnetic flux density = $\mu \mathbf{H}$, and **D** electric displacement = $\epsilon \mathbf{E}$. **D'** is called the displacement current. Equation 1) is Faraday's law, while equation 2) is credited to Maxwell for adding **D'** to Ampere's law, which is $\Delta \times \mathbf{H} = \mathbf{J}$ to maintain charge conservation or charge continuity and thus obtain **J + D'** as the true or total current.

Unfortunately, the understanding of these equations still poses many conceptual difficulties for many people which inevitably lead to shortcomings in the basic understanding of their

engineering applications (and you thought you were alone?). One reason for this lack of insight is perhaps the inability to appreciate the physical meaning of the vector operations curl, div and grad. Many texts and research papers often detail the mathematical intricacies of these vector operations but few describe in practical simple terms their physical interpretation.

In addition to the above, it is often not realized that contained in equations 1) and 2) is the following extremely valuable information: (a) a time-varying magnetic field creates an electric field (or back EMF) and, importantly, (b) a current or a time-varying electric field or both will create a magnetic field. **Please read again and note that you do not need to run current thru a wire to develop a magnetic field.**

The essence of Maxwell's equations, conveyed through points (a) and (b), is that fundamentally they are reactive or field-production equations. The physical, mathematical and engineering importance of the field-production nature may be more readily relayed and understood if the forms of equations 1) and 2) are reversed:

$$3) \mathbf{B}' \Rightarrow - \nabla \times \mathbf{E}$$

$$4) \mathbf{J} + \mathbf{D}' \Rightarrow \nabla \times \mathbf{H}$$

The reversal leads not only to a greater understanding of Maxwell's equations (which is hidden in the non-reversed form) but to a greater appreciation of the nature of time-varying electromagnetics and their associated engineering applications.

One significant engineering application, only fully realized through the reversed form of Maxwell's 4th equation, has been the recent development of revolutionary antenna systems called crossed-field-antennas (CFA) which synthesize directly the Poynting vector $\mathbf{S} = \mathbf{E} \times \mathbf{H}$ from separately stimulated \mathbf{E} (electric) and \mathbf{H} (magnetic) fields. \mathbf{S} is electromagnetic radiation, thus this says there are two (2) components to the radiated field, \mathbf{E} and \mathbf{H} . The \mathbf{X} is defined as the cross product, meaning that they must be properly related both in time, phase, and position. In other words, if you can separately create the two fields and properly combine them, you don't have to have a piece of wire carrying a current. Because of this, **A fundamental feature of these antennas is that the physical size of the structure is small and also independent of the radiated wavelength, a truly remarkable concept in relation to present day antenna theory and design techniques.** (Frame that and hang it on the wall).

The principle of Faraday's Law (equation 1) as detailed by most textbooks, is that an electric field can be related to the rate of change of a magnetic field. This electromagnetic feature can be expressed in a more elegant and informative way by reversing equation 1) to give

$\mathbf{B}' \Rightarrow - \nabla \times \mathbf{E}$ which is interpreted as a time varying magnetic flux, \mathbf{B}' creating an electric field \mathbf{E} such that the negative of the curl of the induced \mathbf{E} field distribution is equal to the source \mathbf{B}' . The directive arrow is present in the relationship to indicate that the left-hand-side causes or

creates the right-hand-side. The negative sign is a manifestation of Lenz's law. In fact, the application of the reversed form of Faraday's law is fully deployed in transformer theory, where a time varying magnetic flux creates, i.e., induces, a back EMF. Note that the \mathbf{E} field in the reversed form of Faraday's law is the induced \mathbf{E} field from \mathbf{B}' and is not in anyway related to the independent electric field created from free charge through Gausse's law.

Consider now equation 2). In magnetostatics, it has always been accepted that current produces a magnetic field though the phenomenon called Ampere's law. To get across the importance of this statement in a more meaningful physical and mathematical form, Ampere's law should be expressed as: **5) $\mathbf{J} \Rightarrow \Delta \times \mathbf{H}$** i.e., \mathbf{J} (current density) creates a magnetic field \mathbf{H} , such that the curl of \mathbf{H} is equal to the source \mathbf{J} . It is also known (though often ignored) that a magnetic field may be related to either a current as above **or** a time varying electric field. The latter source of magnetic field is sometimes refereed to as the Maxwell Law, and may be expressed in the more informative form as: **6) $\mathbf{D}' \Rightarrow \Delta \times \mathbf{H}$** i.e., displacement current \mathbf{D}' (a time varying \mathbf{D} field) creates a magnetic field \mathbf{H} such that the curl of the \mathbf{H} field distribution is equal to the source \mathbf{D}' . We now see the importance of reversing equation 2) to give equation 4), i.e., **$\mathbf{J} + \mathbf{D}' \Rightarrow \Delta \times \mathbf{H}$** , which should now be interpreted as **$\mathbf{J} + \mathbf{D}'$** or both can create a magnetic field \mathbf{H} such that the curl of the \mathbf{H} field distribution is equal to the source **$\mathbf{J} + \mathbf{D}'$** . The plus sign can, and should, be interpreted as analogous to the digital-logic **OR** symbol.

Unfortunately, many people fail to realize that an \mathbf{H} field may, at any time, be the combination of two separately induced fields from independent types of sources, i.e., charge motion and displacement current.

The editor says we are out of space, so we will pick up here next month and apply what we have learned to create a magnetic field without running current thru a wire. This will be accomplished by a simple demonstration. That is essential to the process of building this type of Crossed-Field-Antenna. The heavy theory is behind us so it is down hill from here. Stay tuned. **-30-**

Editor's Note: For your convenience, we have placed one of our new Interactive NotePads below for any questions or thoughts while fresh on your mind. Just type in your message (including E-mail address if a reply is needed) in the NotePad and press the Submit button.

Interactive NotePad

Your E-Mail Address:

Enter comments in box below:

| | |
|---|-------------------------------------|
| Click to Print/Save Article | To Preview Contents |
|---|-------------------------------------|

Send mail to webmaster@antennex.com with questions or comments about this web site.

Copyright © 1988-2000 All rights reserved worldwide - *antenneX*©

Last modified: April 01, 2001

THE MARK II CROSSFIELD ANTENNA

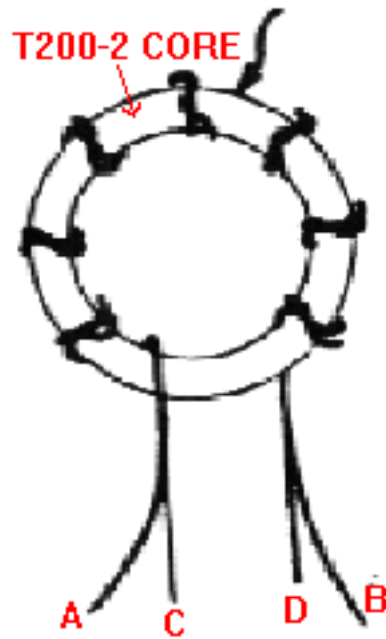
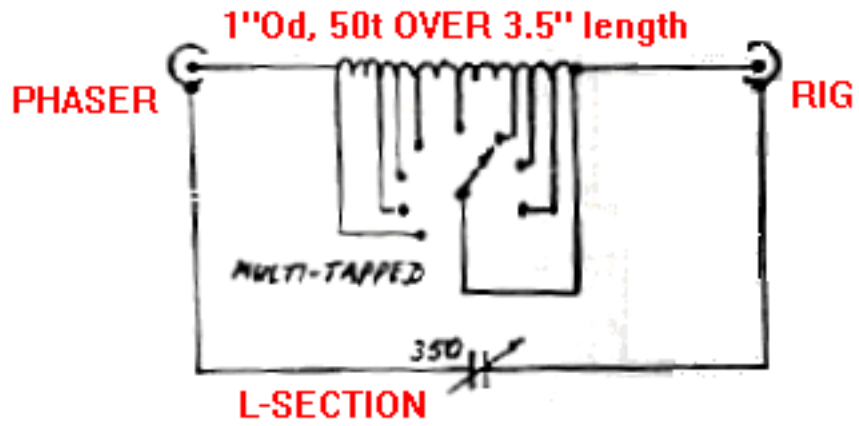

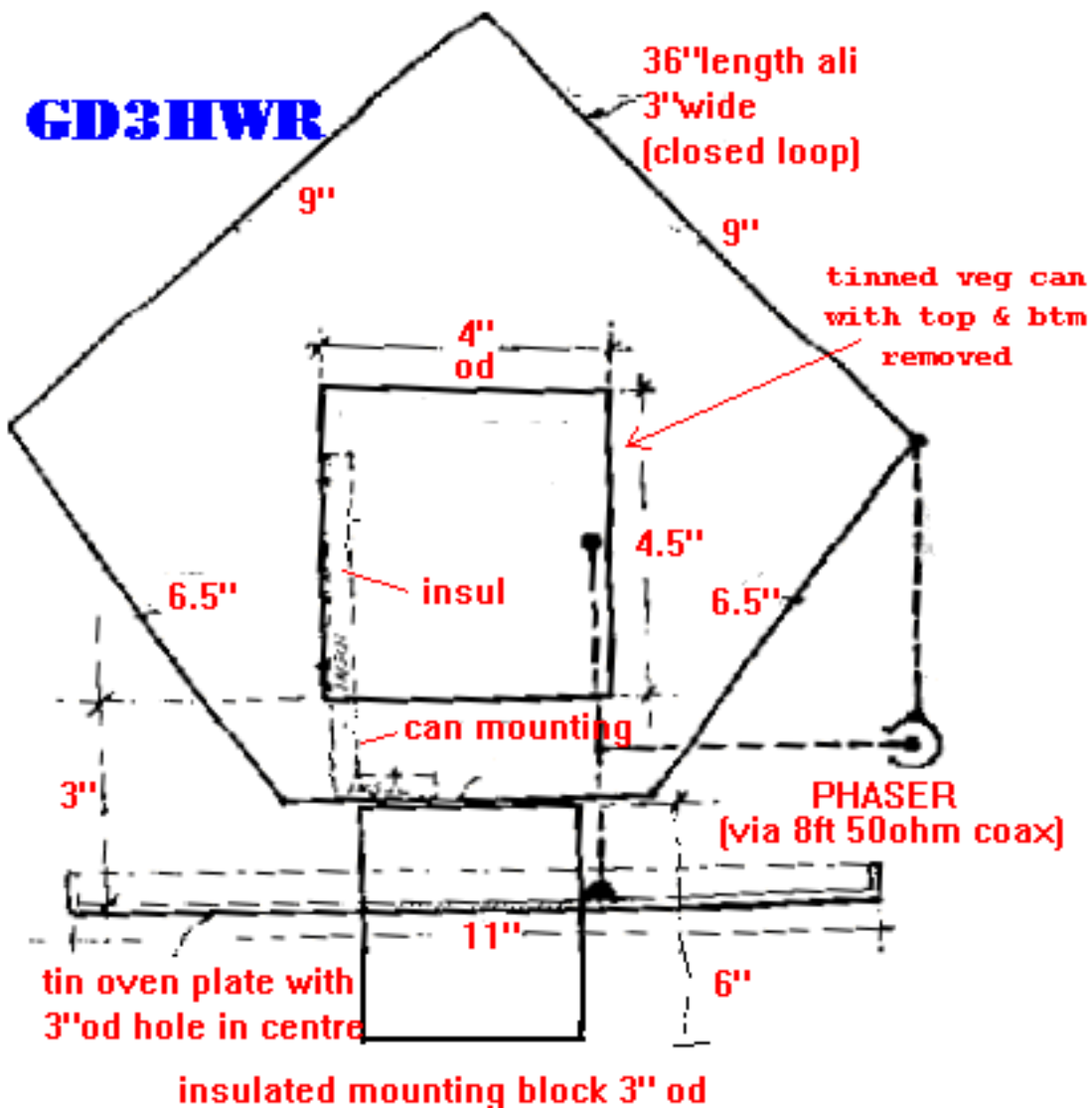
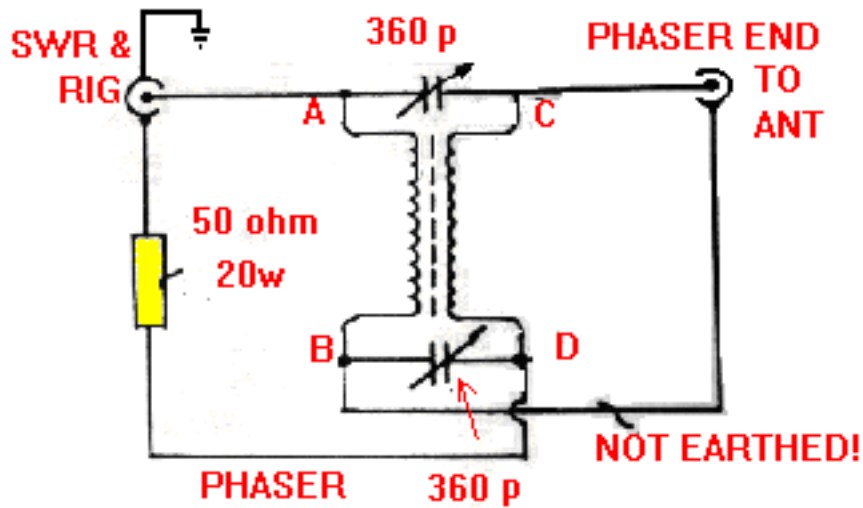

The mark 2 Crossfield Antenna was described in Sprat 76 by Alec, **GD3HQR**. He notes that although it showed no directivity at HF, it was possible to null out time base noise from a TV in an adjacent room. If a valve PA rig with the usual pi section o/p is used, the L-section may not be required. However, it is essential when used with transistor rigs having fixed tuned o/p filters. When tuning the loop, first

approximately tune the L-match by adjusting for maximum RX noise. Then, with QRP, adjust C2 in small steps, at each step adjusting C1 and the L-network for minimum SWR. When this is found, note the settings for future use. Repeat for other bands. Note C2 requires less capacitance at lower frequencies and more at higher frequencies. The author found that, with when properly adjusted, an SWR of at worst 1.5:1 was attained.

It was found that a 1m square sheet of metal - not earthed - placed under the wooden base improved high angle radiation for inter-G working on 3.5/7.0 Mhz.

Note that DC earth is connected to the coax used to connect the L-network to the phaser (it has a capacitive RF earth, which is all that is required).

The author found that his model, used indoors and only six feet above the floor, gave good results on 7 Mhz and above and was 'quite useful' on 3.5 Mhz. It even produced 'the odd QSO' on 1.8 Mhz.

[Click to see a photograph of G3FCK's homebrew CFA](#) (108 kilobytes)

(Please note: I have no personal experience of this system and cannot therefore offer any advice or further information. - Frank, G3YCC)

[Back to the first page](#)



CUBICAL QUAD ANTENNA CALCULATOR

JavaScript PROGRAM by n6ach@comcast.net

thanks to Scott McClements for the round off problem and to Roger KC5LCA for stream-lining the interface

Bye Mir...thanks for the contacts

[Translate this page automatically.](#)

[Españoles](#) [Les français](#) [Deutscher](#) [Italiano](#) [Portuguêses](#) [Japanese](#) [Korean](#) [Chinese](#)

Enter the center frequency: **mHz**

| Elements | Element - Total Length | Wire - One Side | Spreader - Half Length | Spreader - Total Length | Element - Spacing |
|---------------|---------------------------|--------------------|---------------------------|----------------------------|----------------------|
| | INCHES / CM | INCHES / CM | INCHES / CM | INCHES / CM | INCHES / CM |
| Reflector | | | | | |
| Driven | | | | | |
| Director 1 | | | | | |
| Director 2 | | | | | |
| Director 3 | | | | | |
| Director 4 | | | | | |
| Director 5 | | | | | |

Total Boom Length > FEET= INCHES= CM=

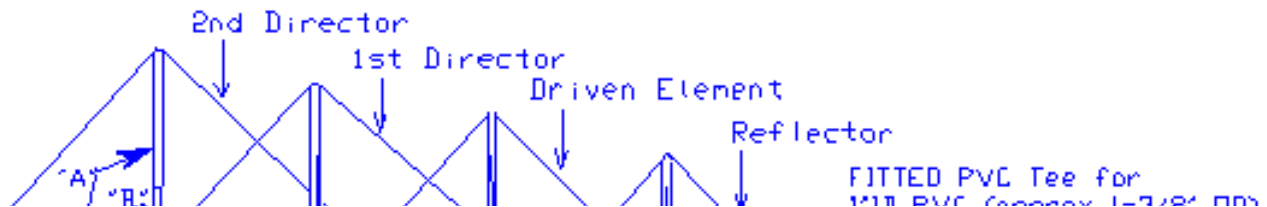

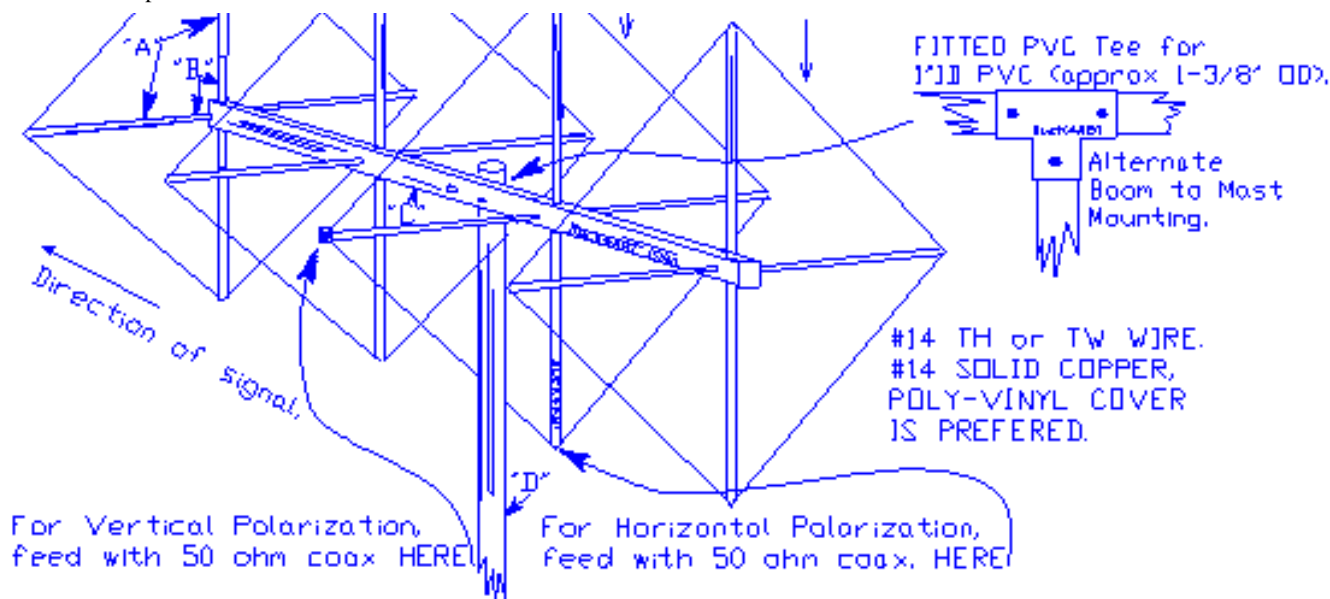

A = 1/2" ID hot/cold PVC. PVC should fit securely over 1/2" OD wooden dowel *B.*

B = 1/2" OD wooden dowel 2 ft long through 1" ID boom. Dowel should extend approximately 9-1/2" out from each side of 1" ID boom. Fit 1/2" PVC (*A*) over dowel. Make sure spreader is long enough to support each wire element length as determined by the calculations below. Once PVC is in place over the wooden dowels, drill with small bit and use short wire or picture hanger nail to secure on the dowel. Hot glue may be used as an additional keeper over the wire or nail head.

C = Boom may be made from square fiberglass or from round PVC 1" ID. Boom is drilled with 1/2" bit at points where wooden dowels are to be inserted.

NOTE: Make sure the vertical and horizontal dowel holes are drilled offset so the dowels will by-pass each other inside the boom. Drill dowels with 1/16" (or smaller) bit each side of boom and secure with small nail or wire to hold (centered) in place. BOOM is thick wall *Sked 40* 1" ID PVC.

D = 1" ID (sked 40/Thick wall) PVC 48" long. Use "fitted" wooden dowel inside to make it more rigid and provide "body" to area where "U" bolts may be attached (rotor head end to boom). See alternate boom mounting.

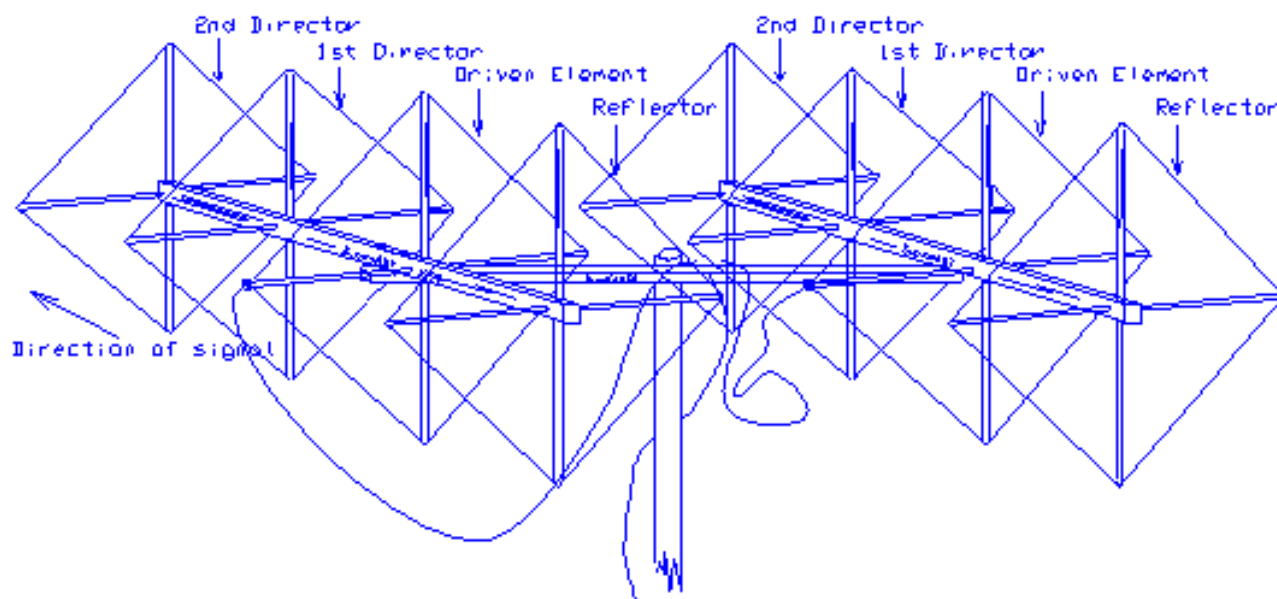

Horizontal "stacking" of quads will improve the signal strength by at least 3 DB.

Drawing used with permission by © 0110 1996-98 G. E. "Buck" Rogers Sr.

| | |
|---|--------------------------|
| <p>Search:</p> <div style="border: 1px solid red; background-color: black; color: red; padding: 5px; display: inline-block;"> Amazon.com logo </div> | <p>Enter keywords...</p> |
|---|--------------------------|

LINKS:

| | |
|--|--|
| <u><i>Antenna System Evaluator</i></u> | <u>N4TUX, a lot of antenna information</u> |
| <u><i>The PacketRadio Operator's Antenna Handbook</i></u> | |
| For some great construction information stop in to <u><i>Scott's quad page</i></u> | |
| <u><i>Trip 2002: Can you imagine loading up a van with 3 teenagers, 1 baby, 2 dogs and a husband and wife to travel halfway across the country? Do they survive? One of the teenagers has studied the Donner Party trip and she packed bbq sauce in her suitcase. One of the dogs is a ridgeback, to those who don't know, they are their own methane greenhouse gas ozone destroying machine. Follow along as we document this event.</i></u> | |
| For more information please check out AC6V INDEX TO DX AND HAM RADIO FEATURING 70 PAGES AND 2000 LINKS <u>AC6V</u> | <u>Site map</u> |
| <u>DANNEX HF-EQUIPMENT, SWEDEN</u> | <u>how I was saved</u> |

Order Practical Antenna Handbook with CD ROM

By Joseph J. Carr. The world's favorite antenna book. The most popular book on antennas ever written, widely known as "the antenna builder's bible," Joseph J. Carr's Practical Antenna Handbook, Third Edition is a work for anyone, ham radio operators, short-wave radio listener's -- anyone with an interest in antennas, from the newest of

novices to the most experienced engineer. This empowering book gives you all kinds of projects, yes. And it gives you material that explains why what you did works. But most importantly, it prepares you to design and construct your own antennas "for the cases," Carr modestly suggests, "That the author thoughtlessly failed to cover." This third edition blends, in Joseph J. Carr's words, "the theoretical concepts that the engineers and others need to design practical antennas, and the hard-learned practical lessons derived from actually building and using antennas--real antennas made of real metal--not merely theoretical constructs on a blackboard." Add it to your working library, and pretty soon it'll assume a favorite spot inside your toolbox, beaten up, tattered, annotated with your personal notes...obviously used to the fullest extent.

Introduction to Radio Broadcasting and Communications. Radio Wave Propagation. Transmission Lines. The Smith Chart. Fundamentals of Radio Antennas. High-Frequency Dipole and Other Doublet Antennas. Vertically Polarized HF Antennas. Multiband and Tunable-Wire Antennas. Longwire Directional Antennas. Hidden and Limited Space Antennas. Directional Phased Vertical Antennas. Directional Beam Antennas. Antennas for Short-wave Reception. Large Wire Loop Antennas. Small Transmitting and Receiving Loops. Wire Antenna Construction. Antenna Modeling Software. VHF/UHF Transmitting and Receiving Antennas. Microwave Waveguides and Antennas. Antenna Noise Temperature. Antennas for Radio Astronomy. Adjusting, Installing, and Troubleshooting Antennas and Transmission Lines. Antennas for Radio Direction Finding (RDF). Impedance Matching in Antenna Systems. Mobile, Emergency, Portable, and Marine Antennas. Antennas for Low-Frequency Operation. Measurement and Adjustment Techniques. General Antenna Mechanical Construction Techniques. Grounding the Antenna: What Is A Good Ground?

Order *Antenna Theory and Design*:

A book on principles and development techniques for examining and designing antenna systems. Emphasis is on basic topics and applications, and much material does not rely heavily on mathematics.

If you have any hints, or comments, please e-mail me at n6ach@comcast.net .

73's de Ron (1Peter 3:15)



03/19/01



This [VHF WebRing](#) site is owned by [KD6DKS](#).

Click for the [\[Previous\]](#) [\[Random\]](#) [\[Next Site\]](#) [\[Skip Next\]](#) [\[Next 5\]](#)

Click here for info on how to join [VHF WebRing](#).





n6ach@comcast.net

vanDarden

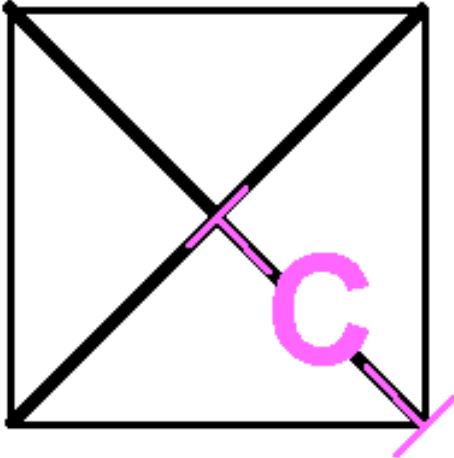

C= Spreader arm Length

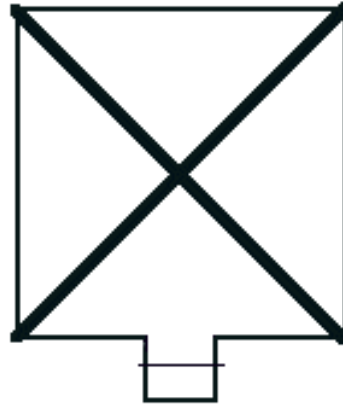

Reflector tuning stub

How to mount and feed.

Horizontal or vertical polarization of an cubical QUAD-Antenna is determined by placement of the feed point (feed gap on the driven element) - Parasitic elements need to be mounted in the same orientation as the driven element. If tuning gap is present on the parasitic elements, doesn't the placement of this gap effect the polarization. Feed line is made out of standard coaxial cable (RG8/RG58) 50ohm unbalanced, to attach this feed line to the balanced drive element (Quad loop) without proper matching is not advisable, instead use an 1:1 balun

[see W2FMI High Power Baluns](#)

Gain vs Spacing

The gain of an antenna with parasitic elements varies with the spacing and tuning of the elements, and thus for any given spacing there is a tuning condition that will give maximum gain this spacing. The maximum front to back ratio seldom, if ever occurs at the same condition that gives maximum forward gain. The impedance of the driven element also varies with the tuning and spacing, and thus the antenna system must be tuned to its final condition before the match between the coax and the antenna can be completed. However, the tuning and matching may interlock to some extent, and it is usually necessary to run through the adjustments several times to insure that the best possible tuning has been obtained.

[Order How to Build and Adjust Quads](#)

or

[The Quad Antenna: A Comprehensive Guide to the Construction, Design, and Performance of Quad Antennas](#)

For some great construction information stop in to [Scott's quad page](#)

Cubical Quad Antenna Design:

By: [Dr. Carl O. Jelinek N6VNG](#)

The frequency scaling formulas for Cubical Quad antennas are shown in Figure 1. Note that frequency is measured in Megahertz {MHz} and the total length of each element is measured in feet {ft}. The spacing of each element is the same and all directors are the same size. The gamma match uses a small air variable capacitor approximately the value given and an adjustable shorting bar at the end connected to the element. The antenna is tuned by adjusting the length of the shorting bar on the gamma match for minimum VSWR with the variable capacitor half engaged. Then adjust the capacitor for minimum VSWR at the mid band frequency. The enclosed [EXCEL program](#) can be used to determine the element lengths and the gamma match values for different frequencies. In general the design is robust and may be optimized for gain or front to back by adjusting the spacing of the elements. This antenna design has been built for both the ten and two meter versions and I have used them for T-Hunting and in two CVARC Field Day events with good results. Figures 2 and 3 show the calculated antenna patterns and performance. Table 1 shows an example output from the EXCEL Scaling program. Figure 4. Shows VSWR vs. Frequency for three different 2 meter antennas, a 4 element Quad, a 6 and a 12 element Yagi.

CUBICAL QUAD ANTENNAS

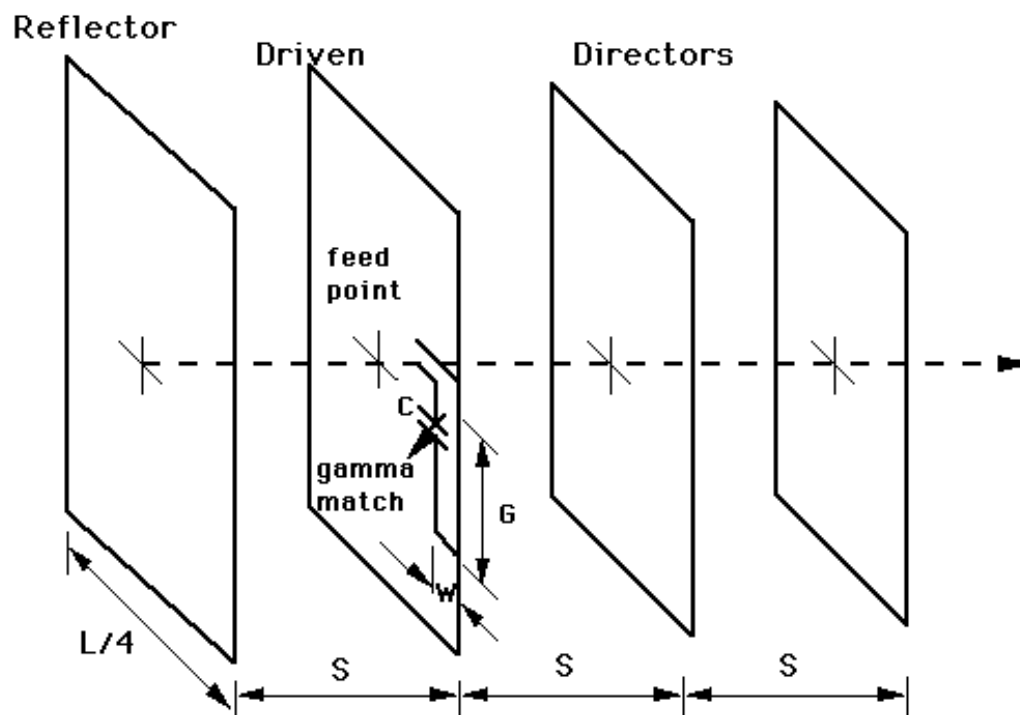

$$L_{\text{reflector}} \{ft\} = 1030/f \{MHz\}$$

$$L_{\text{Driven}} \{ft\} = 1005/f \{MHz\}$$

$$L_{\text{Director(s)}} \{ft\} = 975/f \{MHz\}$$

$$S \{ft\} = 232/f \{MHz\}$$

$$G \{ft\} = 42.75/f \{MHz\}$$

$$W \{ft\} = 13.74/f \{MHz\}$$

$$C \{pfd\} = 2930/f \{MHz\}$$

Dr. Carl Jelinek N6YNG

Figure 1. Cubical Quad Frequency Scaling Equations.

Figure 2. Elevation Pattern for the 4 element Cubical Quad 36" above a perfect ground

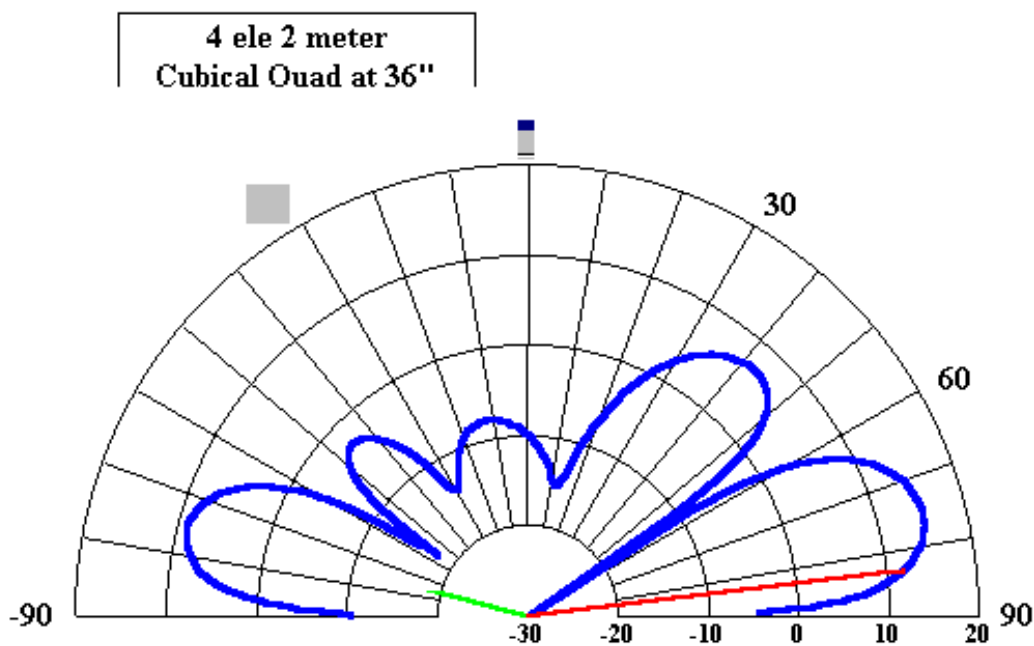
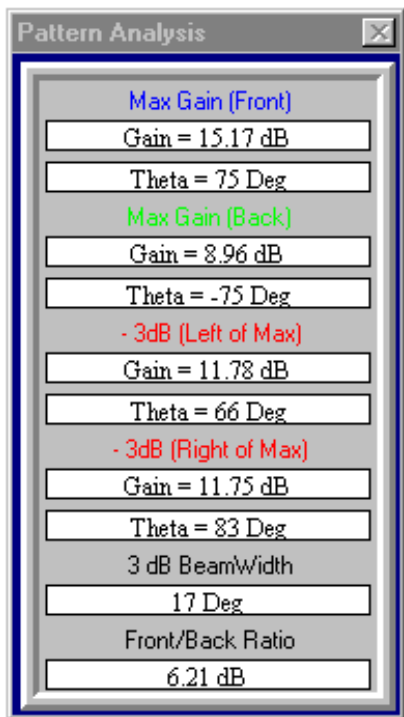

— Total Gain, Phi=0, Freq=146.56 MHz, File=CUBQUAD

Figure 3. Azimuth Pattern for the 4 element Cubical Quad 36" above a perfect ground

4 el 2 meter Cubical Quad
at 36"

Pattern Analysis

Max Gain (Front)
Gain = 15.17 dB
Phi = 0 Deg

Max Gain (Back)
Gain = 8.96 dB
Phi = 179 Deg

- 3dB (Left of Max)
Gain = 12.06 dB
Phi = 331 Deg

- 3dB (Right of Max)
Gain = 12.06 dB
Phi = 29 Deg

3 dB BeamWidth
58 Deg

Front/Back Ratio
6.21 dB

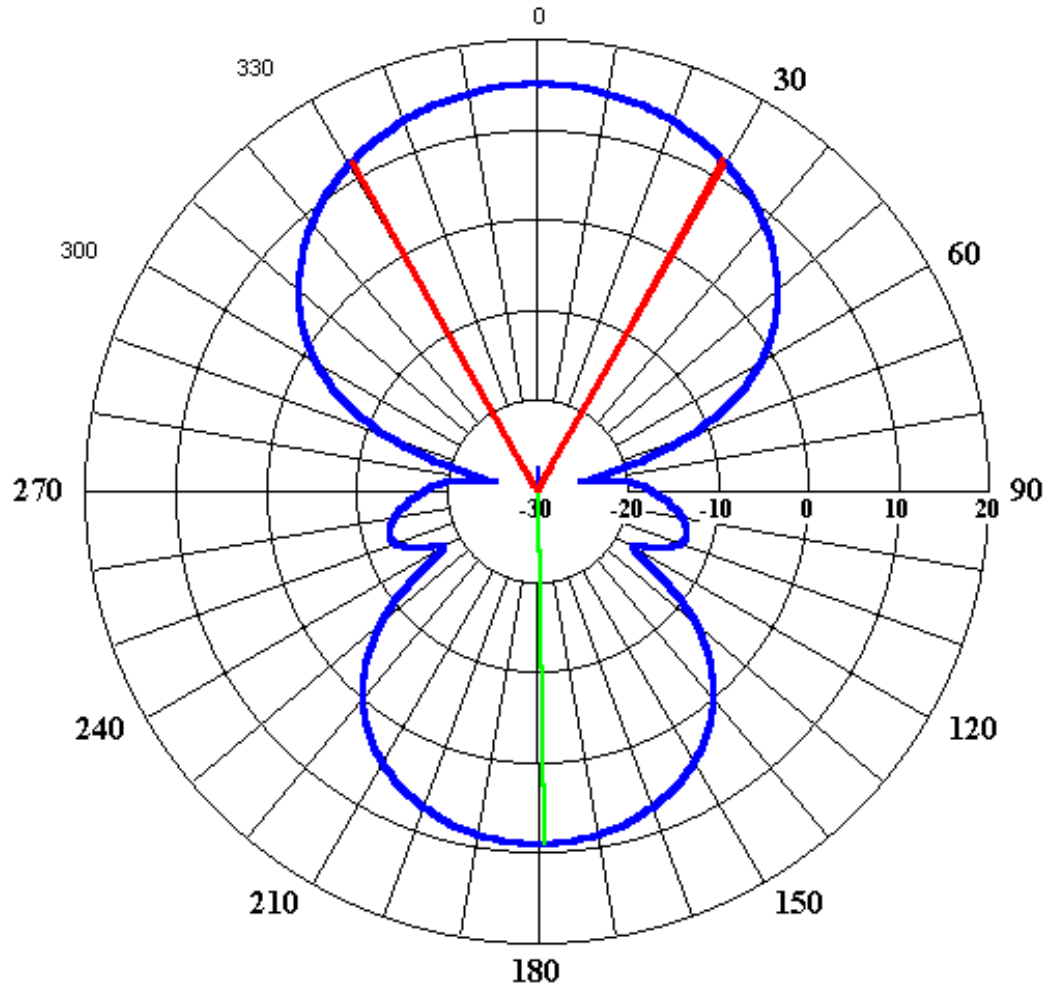

Table 1. Cubical Quad Scaling Relationships

| CUBICAL QUAD | Scaling Formulas | | 3/19/97 22:24 | | | | |
|---------------------|------------------|---------------|----------------|--------------|-------------|-------------|------------|
| Dr. Carl O. Jelinek | Total Length | | All the same | All the same | | | |
| N6VNG | Lr | Ldrv | Ldir | S | G | W | C |
| f=Frequency {MHz} | Reflector {ft} | Driven {ft} | Directors {ft} | Spacing {ft} | Gama {ft} | Width {ft} | Cap {pfd} |
| 146.565 | 7.028 | 6.857 | 6.652 | 1.584 | 0.292 | 0.094 | 20.0 |
| 222 | 4.640 | 4.527 | 4.392 | 1.045 | 0.193 | 0.062 | 13.2 |
| 445 | 2.315 | 2.258 | 2.191 | 0.522 | 0.096 | 0.031 | 6.6 |
| 52 | 19.808 | 19.327 | 18.750 | 4.463 | 0.822 | 0.264 | 56.3 |
| 28.5 | 36.140 | 35.263 | 34.211 | 8.144 | 1.500 | 0.482 | 102.8 |
| Notes: Scaling | Lr = 1030/f | Ldrv = 1005/f | Ldir = 975/f | S = 232.1/f | G = 42.75/f | W = 13.74/f | C = 2930/f |

VSWR vs. Freq.

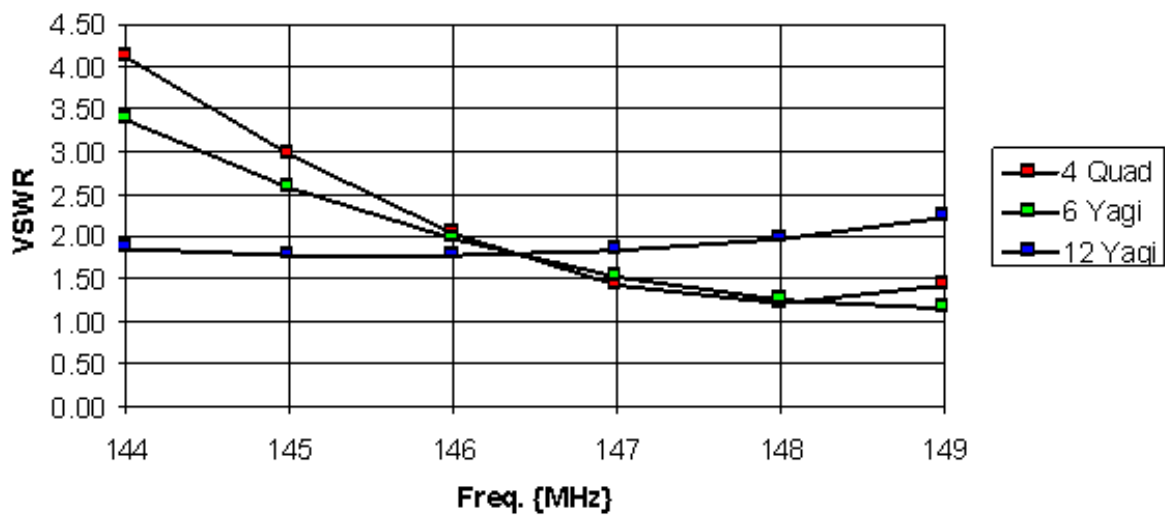

Figure 4. VSWR vs. Frequency for Three 2 Meter Antenna Designs.

[Home](#)

[Links](#)

[Contact Information](#)

Copyright © 1997 - 2004 - John Tait EI7BA - All rights reserved

EI7BA's Amateur Radio Pages

[Home](#)

[Links](#)

[Contact Information](#)

[Multiband Cubical Quad](#)

[An Hexagonal Beam in 3 hours](#)

[80/40m Vertical \(+160M at a push..!!\)](#)

[Cushcraft R5/R7 Maintenance and Repair](#)

[Antennae for the Low Bands 80 and 160m](#)

[A Ball hitch Mobile mount](#)

[Crank-up Tilt-over Tower](#)

[Remote Antenna Switching](#)

[Automatic Band Decoders](#)

[Troubleshooting Traps](#)

Visits



Mirror at qsl.net

Email address **bravo at **iol** dot **ie****

Locator / Grid Square : IO51VT Worked All Ireland Square : W86 Cork



EI7BA's gear June '04



[Home](#)

[Links](#)

[Contact Information](#)

Copyright © 1997 - 2004 - John Tait EI7BA - All rights reserved

Cubic Quads

KQ6RH

(C) 1998, 1999, 2000

Ray Jurgens

(Up-Dated 2/25/2000)

Cubic Quads

The cubic quad is a very popular way to get reasonably high gain and excellent front to back ratios as well as low angles of radiation for without going to extreme heights. Here I present several designs that that achieve the great performance that hams have associated with this antenna for years. Data are presented for 2 and 6 meter quads and a combined 2 and 6 meter quad that is optimized. The 2 meter 3 element design gets a great 9.5 dBi gain coupled with a F/B ratio of 23 dB.

Light weight portable cubic quads can be constructed rather easily from fiberglass tubes supported by central hubs. You should be familiar with the material presented in the [Quad Loop](#) and [Pfeiffer Quad](#) sections of the Antenna Magic page. Cubic quads for wavelengths shorter than 15 meters are easily constructed, however, you should be aware that the weight of these structures is larger by a factor of about 3 relative to most of the planar designs presented in the main menu. Because of this, a heavier mast must be used to support the structure in most cases. Also, be aware that the space needed to assemble and raise a full cubic quad is larger than for the planar designs, and this may be a significant limitation imposed in some locations. In my own case, the backyard associated with my town house is barely large enough to assemble a cubic quad with spreaders of 8' in length. Wires and guy cords get tangled in the fruit trees, and spreaders hang over into neighbor's yards. Anything larger 8' with extended spreaders is essentially impossible to assemble without working above the level of the fence and fruit trees. For that reason, I shall present only two designs which are more or less typical of what can be done easily. The two designs presented are for HF and VHF and should be useful to a wide audience. The HF design is a two element quad for 10, 12, and 15 meters while the VHF design is a two element design for 6 meters with three elements for two meters. A specific advantage of the standard quad design is that multi-band operation is easily accommodated.

2 and 6 Meter Quad

The spreader length necessary to support a 6 meter quad is less than 3.5 feet, so the standard 8' lengths of fiberglass tubing can be cut in half to make 4' sections. It is also possible to telescope shorter sections of 1/2" and 1/4" tubing to make a slightly lighter weight design. In that case, the 8' sections could be cut in quarters and the overlap of about a half a foot would be entirely adequate for the telescoping leaving spreaders of about 3.5 feet. The boom length for a full quarter wave spacing is less than 4.75 feet, so a single 8' piece of 1" fiberglass tubing is more than ample.

Looking quickly at the 2 meter requirements, the spreaders need be no longer than 1.25 feet and a three element wide spaced boom requires no more than 31.25", thus this can be easily tucked between the 6 meter 2 element quad. In fact, it is necessary to stretch it out a bit. So, a common design requires beginning with an optimized design for 6 meters and accommodating the 2 meter design to the locations of its two hubs. The third 2 meter hub occupies a space between the two 6 meter hubs.

Looking at an optimized 2-element 6-meter design, the following parameters give excellent performance:

| Parameter | Length in " | Length of Loop in " |
|--------------------|-------------|----------------------------|
| Reflector Loop | 21.42 Side | 85.70 |
| Driven Loop | 20.60 Side | 82.38 |
| Director Loop | 20.18 Side | 80.72 |
| Reflector Location | -11.77 Boom | Relative to Driven Element |
| Director Location | 19.44 Boom | Relative to Driven Element |
| Total Boom Length | 31.21 Boom | |

Table 1
Dimensions of a 3 Element Cubic Quad for 2 Meters

The 6 meter parameters are given in Table 2, which is a simple two element design:

| Parameter | Length in " | Length of Loop in " |
|----------------|-------------|---------------------|
| Reflector Loop | 58.91 Side | 235.64 |
| Driven Loop | 55.87 Side | 223.48 |
| Boom Length | 47.41 Boom | |

Table 2
Parameters for 6 Meter 2 Element Quad

The next step is force the 2 meter 3 element quad to have a total boom length identical to that of the 6 meter quad. Note that the 2 meter 3 element easily fits within the same space as the 6 meter 2 element, that the 2 meter quad will have a longer boom than is considered optimum.

(To Be Continued)

10, 12, and 15 Meter Quad

The construction of 2 element cubic quads for 10, 12, and 15 meters is not very difficult, but the structure requires some guy strings to keep the light weight elements from bending. The bending actually would not degrade the performance very much, but the nice square structure clearly looks better, and it will probably hold up better under high winds. In order to keep the spreaders from bending due to gravity loading and wire loading, you will need to have a place to guy them from two directions. The antenna wires can serve as structural elements to help reduce the bending in the plane of the loops. However, bending is also a problem perpendicular to the plane of the loops, and guy strings are necessary to stabilize that direction as well. The easiest way to provide a place to connect the guys is to use a boom extension. The extension does not need to be any longer than 3 feet for 8' spreaders. In the case of 15-meters, the boom can be about 8', and the two extension increase the boom to 14' or a turning radius of 7'. The actual turning radius of a quad depends upon whether it is set up as a diamond or square configuration, the square being the smaller of the two.

[Return to Main Menu](#)

[GO TO HOME PAGE](#)

[Theory](#) - [Practice](#) - [my Quad](#)

MY QUAD (2 EL. FOR 10-12-15 MT)



I built two quad (one to me, the other to Mario, ik7zcg).

I used "+ " ("Diamond") configuration which gives just 0,1-0,2 db more in the gain than "Square" configuration: I built it in this way only for mechanical reasons. I used square-aluminum boom 30*30*1 mm 180 cm length; into it I put a steel pipe just to make it stronger; the mast to boom attachment comes from a CB antenna (\$6)([see picture 1](#)).

The spreader to boom attachment (one for each element) is home-made using a square-steel bar (35 cm length); on the tips there are 4 perpendicular

pipe (25 mm diameter) where you'll insert poles ([see picture 2](#)).

Poles are 5 mt length (21 mhz); I use four bamboo poles for each element (\$1 each); each pole is 240 cm length so I made it longer using in the lower part a short aluminum pipe (25 mm diameter, 100 cm length).

I gave the poles a protective coat of boat-paint and then I covered it with PVC ribbon (thanks to Jan, G0KRL for info).

Loops are on copper-insulated multi-wire (1mm for my quad, 3mm for Mario's one).

Here are formulas for loop length:

$$L(\text{Driven})=7658/F$$

$$L(\text{Reflector})=7849/F$$

$$L(\text{Director})=7430/F$$

L=Length for one side.

I never spent time tuning it (it's "no problem, no tune", and works fine!) but I know working some hours I can optimize Gain or F/B Ratio ecc.

I fed driven elements with 3 (one for each band) 1/4 lambda stub using TV 75 Ohm cable; on the Mario's quad i used RG 11 useful for high power; over the outside of the feed line, near the feed point, there are some ferrite beads taped up and sealed against moisture: that's my balun ([see picture 3](#)); on the boom there's also the rele' box for antenna switch ([see picture 4](#)); then a common 50 ohm RG 213 goes down on the shack.

I suggest you do not solder the stub directly on the loop, but using a SO239: here it's still working fine but will be better how i suggest.

The weigh of my quad is about 15 Kg.



HOW DOES IT WORK?

Oh guys! It works very fine! My quad is only 8 mt up, but it never performed worse than a 3 element yagi (sometime I hear what yagi doesn't; I don't know why european stations give me better reports than mine (If I give them 5/7 they give me 5/9, 5/9+); with Dx station reports are the same. The same occur with F/B Ratio: it's about 15 db with european stations, more with Dx.

Using the quad I forgot my antenna-matcher: SWR is less than 1:1,6 at the end of the band;

I think home-brew this antenna is easy: everybody can do it! I spent less than 100\$ and I have a very fine beam; may be this summer I'll add 18 e 14 loops but this is an other story...

73 de iz7ath, Talino

Quad Loops

KQ6RH

(C) 1998, 1999, 2000

Ray Jurgens

(Up-Dated 2/25/2000)

Quad Loops

Quad loops can be a practical way to get some gain without constructing a full Cubic Quad. The free-space gain of a square loop is about 3.13 dB which is a little improvement over a dipole. If you raise the center of the loop up just one half wave length, a peak gain of 7.75 dBi is reached near 24 degrees elevation. This is not too bad for a simple antenna, and even for 20 meters, the center height will only be about 32 feet. You have the choice of either horizontal or vertical polarization and the decision as to whether to set the spreaders up as a cross or and X. Most people choose horizontal polarization which places the feed at the bottom of the loop. The cross or X selection may depend upon the structure and how close the antenna is to the ground. Normally, the X construction can be more stable in that the weight of the wires is supported by two spreaders while a single spreader must support the entire wire mass as well as part of the weight of the horizontal spreaders in the cross configuration. The cross configuration has definite advantages in height over the X and puts more of the wire at a greater height above the ground. This configuration puts a high current region at the upper apex and gives a better elevation pattern for a given height of center above ground. And if you live in lands of snow and ice, the water runs down the wires and off the corners rather than freezing to the horizontal wires. A definite advantage!

I have constructed quad loops for several bands, but most of my effort went toward a 17 meter loop using 1/2" diameter spreaders extended by 1/4" telescoping sections approximately 2 feet long. There are few secrets to success here, however, the information in the ARRL handbook for driven elements seems to give antennas that are a little small, but that could be due to my environment. The ARRL Antenna book gives the formula $1005/f\text{Mhz}$ for computing the length of wire needed for the full loop. It may be better to begin with $1030/f\text{Mhz}$ and cut back if the frequency comes out too low. The #14 flex-weave wire is a good choice as it stretches out easily, however, it is definitely over-kill and much lighter wire can be used.

The driving impedance of these loops is a little inconvenient, mine measured about 130 Ohms which agrees well with theory, so a 2:1 balun is recommended or a quarter wave of 75 Ohm

line as a matching section. I have found it a bit of a trick to make a good balun that raises the impedance by a factor of two, but there are excellent directions in Jerry Sevick's, W2FMI, book "Building and Using Baluns and Ununs." It is important to make the characteristic impedance of the transmission line winding 100 Ohms as directed, otherwise the high frequency properties will be compromised. An alternative way to feed these loops is to use 300 Ohm twin line or ladder line. I've used a half wave length of 300 Ohm foam filled line with good results by connecting to the balanced line terminals on the antenna tuner. This presents roughly 130 Ohms to the tuner that is expecting 200 Ohms for a perfect match. This small SWR is easily tuned out. And, if weight is an issue, then this is definitely the way to go!

Let's consider the spreader length. Using the formula for the wire length ($1005/f\text{MHz}$), we see that the spreader must be at least $(1005/f\text{MHz})/(4*\sqrt{2})$. For 15 meters, this comes out to about 8.4 feet. Thus, short extensions to the 8' spreaders are required. The extra 0.4' is really no problem for 1/4" rods or tubes, but 17 and 20 meters require special attention. The spreaders for 17 meters must be about 9.82 feet, or an extra 1' 10". In the case of 20 meters, the extensions need to be 4.5'. This latter case is really pressing the limits of what can be done with the light weight materials. All versions of the quad loops require guy lines for wavelengths longer than 15 meters. This means that you must have a boom section that extends about three or four feet either side of the hub. The guy lines can be Nylon fish line, however, Kevlar line works better in this application, because it does not stretch like the Nylon and the lengths can be accurately calculated. Even with guy lines, the 20 meter loop will require lighter wire, i.e., you will not be able to stretch out #14 flex-weave on this structure. Although the 15 meter structure can be managed without guy lines, the spreaders can be bent out to tension the wire. Using #20 stranded copper wire will cost less than 0.25 dB of gain. So you could use stranded hook-up wire. This wire normally comes with insulation, so, you could strip it off exposing the wire to weather, or leave it on and shorten the length by a few percent to compensate for the dielectric loading. I suggest that you leave the insulation on, and buy black Teflon insulation to make the wire less visible. Radio Shack offers a black #18 hook-up wire that also works well.

The construction of loops for 2, 6, 10, 12, and 15 meters is rather straight forward, so the parts list is short. The construction of loops for 17 and 20 meters requires more extensive guy lines, so the parts list grows to cover extra guy ties and spreader extension. We suggest using a short boom with guys for all bands longer in wavelength than 12 meters. As a short boom is required to put the hub in vertical position, adding extra length to the boom and the extra guy lines is really no inconvenience and provides a much more stable structure. Loops for 2 and 6 meters require no guys at all. You should order only enough 1/2" tubing to make the four spreaders for the VHF loops. The 1/2" Guy Ties are convenient for mounting the wire.

In all cases, you will need a mast-to-boom plate with appropriate U-bolts for mounting the 1" boom to the upper mast section. You also must decide if the hub or the boom plate is to be in the center, i.e., both can not be in the center of the boom. In general, it is simpler to put the hub in the center in that all the guy lines can be cut the same. This choice slightly unbalances the the weight at the top of the mast, but this can be compensated easily by adding weight (fishing

sinkers) to the shorter side of the boom relative to the boom plate. The construction of boom plates is given in detail in the ARRL Radio Amateur's Handbook. The material of choice is usually aluminum, however, I have been using 1/4" PVC plates with success, and it is even easier to cut and drill than the aluminum and seems to have adequate strength. I have been using four U-Bolts on both the mast and the boom, i.e., two on each side of the mast and boom.

You should order the following parts for 10 and 12 meters:

| Item | Quantity | Description |
|------|----------|---|
| 1 | 1 | HUB 4-050-100, Central Quad Hub (RFJ) |
| 2 | 4 | 8' 1/2" OD fiberglass tubing, spreaders (MGS) |
| 3 | 1 | 8' 1" OD fiberglass tubing, boom (MGS) |
| 4 | 4 | GT 4-050 1/2" Guy Ties, for tips of spreaders (RFJ) |
| 5 | 2 | GT 4-100 1" Guy Ties, for tips of boom (RFJ) |

Additions for 15 meters:

| Item | Quantity | Description |
|------|----------|---|
| 6 | 1 | 1/4" OD fiberglass tubing, spreader extensions, quarter it! (MGS) |
| 7 | 4 | 1/2" stainless steel hose clamps, compression clamps for extensions |
| 8 | 4 | GT 4-025 1/4" Guy Ties, for tips of extensions or wire attachment (RFJ) |

Additions for 17 meters:

| Item | Quantity | Description |
|------|----------|---|
| 9 | 1 | 8' 1/4" OD fiberglass tubing, spreader extension, halve it! (MGS) |

Additions for 20 meters:

| Item | Quantity | Description |
|------|----------|---|
| 10 | 2 | 8' 1/4" OD fiberglass tubes, spreader extenders (MGS) |
| 11 | 8 | GT 4-050 1/2" Guy Ties for cross truss ties, (RFJ) |

Note, the spreader extenders can be full 8' lengths of 1/4" tubing, i.e., you don't need to cut them, but you can reduce the weight slightly if you do. They can be cut to 5' lengths leaving 3'

pieces for use with smaller quads. The 20 meter structure requires cross truss guy lines (for details see our Construction Page). These require more guy tie points near the centers of the 1/2" spreaders. It is easier to align the tensions if the Guy Ties are separate for the interior and exterior guys, but common tie points can be used if the guy lengths are cut accurately. The total number of guy lines is as follows:

| Item # | Quantity | Approx. Length ft. | Description |
|--------|----------|--------------------|---|
| 1 | 8 | 9.0 | interior spreader to boom posts (4' post assumed) |
| 2 | 8 | 13.2 | exterior spreader extension to boom posts |
| 3 | 4 | 11.3 | interior perimeter guys (could be wire loop) |
| 4 | 4 | 17.7 | exterior perimeter guys (could be wire loop) |
| 5 | 8 | 9.0 | interior cross lateral trusses |
| 6 | 8 | 13.2 | exterior cross lateral trusses |

Table of Guy Line Lengths and Definitions

for a grand total of 40 lines requiring 80 attachment clips and a total length of material of 1084.4 ft. You should plan a full day for the first construction of the 20 meter loop. Once assembled, the antenna can be disassembled in about the time required to roll up the guy material. Re-assembly takes about an hour.

[Return to Main Menu](#)

PA0FRI**RadioZendAmateur/HAM, Frits Geerligs, QTH: Etten-Leur****PA0FR**

FHV Geerligs, A-class NL Licence/CEPT-class morsecode included

Technical Homepage for HAM's

| | | | | | | |
|----------------------|------------------------|----------------------|--|---------------------------|-----------------------|-------------------------|
| INFO | PA0FRI | HAMS | UPDATED 06sep2004 | BIOGRAFIE | LINKS | CONTACT |
| QRO | ANT | ATU |  | MODS | MISC | PS |

Een aantal onderwerpen met veel foto's zijn ingekort omdat de limiet van 25 MB bij de server bijna bereikt is.

Informatie

Doel

Deze eenvoudige site geeft informatie over mijn experimenten, lopende projecten, modificaties en eerder gepubliceerde ontwerpen. Teksten, schema's, foto's en artikelen worden aangepast of toegevoegd als er nieuwe ontwikkelingen of inzichten zijn. Artikelen mogen elders gepubliceerd worden als u de bron erbij vermeldt.

Reden

Veel heb ik geleerd van artikelen die door andere zendamateurs geschreven zijn in Electron en andere electronica bladen. Als tegenprestatie probeer ik hetzelfde te doen voor anderen.



Doelgroep

Volgens vele zendamateurs wordt tegenwoordig in tijdschriften van verenigingen een onderwerp veel te theoretisch gepresenteerd. Daarom zal hier zoveel mogelijk de praktische kant toegelicht worden. Beginnende of nog onervaren zendamateurs worden dan mogelijk ertoe aangezet om ook eens te experimenteren of zelf iets te maken. U hoeft zich niet te schamen, begin eenvoudig en bedenk dat velen over zelfbouw praten, maar het verder daarbij laten. De meeste kennis wordt opgedaan door het zelf te doen. Tijdens het bouwen en experimenteren wordt inzicht verkregen, vooral als het niet meteen lukt of er iets kapot gaat. Men gaat fout zoeken, meten, vragen, lezen en proberen. Als tenslotte het zelfbouwproject goed werkt of de koopdoos door u is gerepareerd, verbouwd of afgeregeld, dan is de voldoening niet te beschrijven. Er is geen drempelvrees meer en een verlangen naar een volgende uitdaging is een feit.



Activiteiten PAØFRI



Mijn voornaamste bezigheden zijn experimenteren, bedenken, veranderen, proberen, "ontwerpen" en af en toe publiceren. Er zijn ongeveer 20 verschillende praktische onderwerpen van mijn hand verschenen in ELECTRON (14), CQ-PA, Radio Communication, CQ Friese Wouden, QRP NIEUWSBRIEF en andere tijdschriften die artikelen hebben overgenomen. Zelfbouw wordt ook veel gedaan, maar als alles naar wens werkt neemt de belangstelling af. Vaak wordt het bouwsel weer gedeeltelijk of volledig gedemonteerd om over onderdelen te beschikken voor een ander idee. Als het de bedoeling is om het apparaat te gebruiken, wordt het ook netjes afgebouwd, maar het afwerken van de frontplaat laat nog wel eens lang op zich wachten. Veel schakelingen en andere bedenksels die hier getoond worden zijn eigen ontwerpen. Praktische ervaring is vooral opgedaan met antennes, antenne tuners, baluns, HF versterkers, ontvangeringen, mixers, AF& HF spraak processors en 2m transistor eindtrappen.

Voornameijk wordt gewerkt op HF met een gemodificeerde Ten Tec Corsair II, R5 vertical en inverted zelfbouw W3DZZ gevoed met openlijn via een S-Match symmetrische antennetuner.

Er zijn zelfbouw lineaire versterkers FRI-400 (4 x PL519 400W), FRI-750 (TB3/750, 750W), een gemodificeerde Ten Tec Centaur (3 x 572B, 800W) en een opgeknapte Heathkit SB-200. In ontwikkeling is een FRI-1500 (1500W) met een Russische tetrode GU-43B in een passief rooster schakeling. Lineairs worden zelden daadwerkelijk ingezet op HF banden. Het bouwen is leuker en zij worden het meest gebruikt om tuners, dymmy-loads, low-pas filters, coaxkabels en openlijn te testen.

Inmiddels zijn ook vele anderen geholpen bij het oplossen van problemen met hun HF versterker.

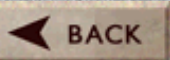

Hams

| | | |
|---|---|---|
|  Benelux QRP Club |  PGØG techniek |  DL1SDQ components |
|  G-QRP Club |  DL5JYN QRP stuff |  HA8UG amps, components |
|  American QRP Club |  ND2X linears HF/VHF |  AC6V ant projects, mni info |
|  German QRP Club |  KO4NR mods with sweep tubes |  DF2OK mni info via links |
|  PA3ESZ mni info |  WB6BLD meter scale prog |  SM0VPO homebrew |

 BACK

 BACK

Biografie PAØFRI

Toen ik 10 jaar  was zijn de eerste schreden  op het electronicapad gezet met het bouwen van een kristalontvanger. Wie deed dat destijds niet? Niet veel later doneerde een radioknutselaar uit de buurt mij een paar oude "lampen" en andere onderdelen. Daarmee zijn onder zijn supervisie rechteuontvangers gebouwd.

De volgende stap was de zelfstandige bouw van een supertje met 1.4V batterijbuizen. Destijds een sensatie als je als enige met een draagbare ontvanger (formaat kleine koelbox) op het strand van Castricum en Scheveningen verscheen. De 90 V batterij was veel te snel leeg en een nieuw exemplaar was een behoorlijke aanslag op het zakgeld. Verder zijn veel projecten nagebouwd uit Radio Bulletin, Radio Electronica en Jongensradio delen 1, 2 en 3.

Daadwerkelijke kennismaking met het zendamateurisme vond plaats in 1961. In dat jaar werd ik CW operator van PI1KMA. Één van de verantwoordelijke zendamateurs was wijlen Henk, PAØDB. CW lessen konden op vrijwillige basis gevolgd worden en samen met instructeur van Lieshout heeft hij mij de edele kunst van  morse seinen en opnemen geleerd. Hun geduld werd op de proef gesteld omdat de leerling niet paste bij de gangbare lesmethode, hi! Gelukkig werd de drill losgelaten en met bijlessen in de schaarse vrije tijd is een ontbrekende morsevaardigheid nog betrekkelijk snel opgedaan.



minuten geregeld!



Een paar jaar later is met goed gevolg  examen gedaan voor een A-machtiging en de overheid gaf een "bevoegdheid" af. Een zender moest toen een half jaar na het examen ter keuring aangeboden worden als meteen de call werd aangevraagd. Zag men ervan af dan werd een "bevoegdheid tot het bedienen van..." verstrekt. Daarmee is regelmatig als gastoperator bij clubstations of andere zendamateurs gewerkt. De eigen call PAØFRI is pas in maart van 1969 telefonisch aangevraagd en toegewezen. Toen kon dat nog en was het binnen een paar

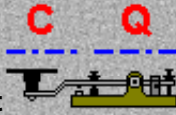

Gestart werd met en EL500 in een eigenbouw 30W CW zender. Ook de ontvanger was een zelfgebouwde Semcoset Semiconda.

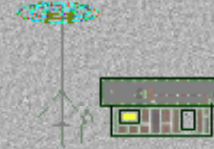

Het bouwpakket kwam van Schaart die zijn commerciële activiteiten in zijn woonhuis begon.

De eerste antenne, een 5 m legerspriet, was schuin gemonteerd tegen het 60 m lange metalen balkon. De flat lag op de zesde en hoogste verdieping en daarom was ik tijdens een pile-up er meestal als eerste bij. In 1982/1983 is gewerkt met PAØFRI/OD tijdens een UNIFIL missie in Libanon. Begin 1993 is mij in het voormalige Jugoslavië als UNPROFOR waarnemer in Croatië een machtiging verleend met de call 3A/PAØFRI. Daarmee is in de omgeving van Dubrovnic gewerkt. Vermoedelijk ben ik een van de eersten met een officiële geldige schriftelijke Croatische machtiging, want lokale amateurs hadden nog documenten met een YU prefix. Tijdens die periode is ook nog gewerkt op het clubstation van Goràzde in Bosnië.

Verder ben ik ongeveer acht jaar VERON/VRZA QSL manager geweest voor amateurs in Etten-Leur en twee jaar voorzitter van de VERON afdeling Breda.

De advertentie site www.zendamateur.2dehands.nl is door mij opgestart als service voor collega radiozend- en luisteramateurs. Het is een min of meer zelfstandige dochter van 2dehands.nl. Voor het beheren en bewaken krijg ik geen vergoeding. Helaas word ik regelmatig lastig gevallen met onbeschofte email van lieden die zich niet voor kunnen stellen dat alles pro deo gedaan wordt in mijn toch al schaarse vrije tijd.

Door het experimenteren en af en toe publiceren krijg ik onderdelen van andere amateurs en daarvoor wil ik hen hierbij nog eens bedanken. Hun spullen zijn respectievelijk kapot gegaan, werken nog, zijn ingebouwd of liggen klaar voor een volgend project. Ter geruststelling, ik heb ze nooit verkocht, maar een enkele keer weggegeven aan een andere experimenterende of zelfbouwende zendamateur.



Links

| | | |
|---|--|--|
| ● Zendamateurs pagina | ● Zendamateurs boogo links | ● Mods.dk (veel modificaties) |
| ● Zendamateurs startkabel | ● Zendamateur 2dehands | ● Mirror site voor www.mods.dk |
| ● Kent voor componenten | | ● Beoordeling apparatuur (reviews) |



Contact



| | | | |
|-----------------------|---|---|---|
| E-mailaddress: | pa0fri@planet.nl | pa0fri@amsat.org | |
| Webaddress: | http://home.planet.nl/~fhvgeerligs | http://www.pa0fri.geerligs.com | http://www.qsl.net/pa0fri |



Visitors  Bezoeker

\$B\$3\$3\$,!V%[!<%`%Z!<%8!W\$i\$7\$\$ (J

2004/06/04

These Pages are written and managed by
[IDEHARA, Norimichi](#)

0020222

\$B\$\$\$6?\$\$r\$H\$i\$s (J

June 4, 2004

\$B!!Bg2H\$5\$s\$, (J HOMEPAGE

\$B\$J\$I\$H\$\$\$&\$?\$o\$1\$?%"%I%1%9\$K0\9T\$7\$m\$H\$;\$C\$D\$/\$N\$G!";EJ}\$J\$/0\9T\$7\$^\$7\$?!#5o?4CO\$,0-\$\$\$N\$G!"0z\$C1[\$7@hC5\$7\$F\$\$\$^\$9!# (J

| | |
|-----------------------------------|--------------|
| \$B&5f< | moved! |
| \$B&5f< | 2002/12/17 |
| \$Bsw@W (J | 2003/01/08 |
| \$BEEG>;Y:Y (J | 2004/06/04 🚨 |

[IDEHARA, Norimichi](#)

NOTICE:

The Curmudgeon's Corner Ham Radio
Pages have moved!

You will be directed to the new site in approximately 5
seconds.

Once there, please bookmark the new site and update any
links.

Thanks for visiting! Enjoy your stay in ...

The Curmudgeon's Corner.

Click [HERE](#) for the current FOR SALE, WANTED TO TRADE, and WANTED TO BUY listings!

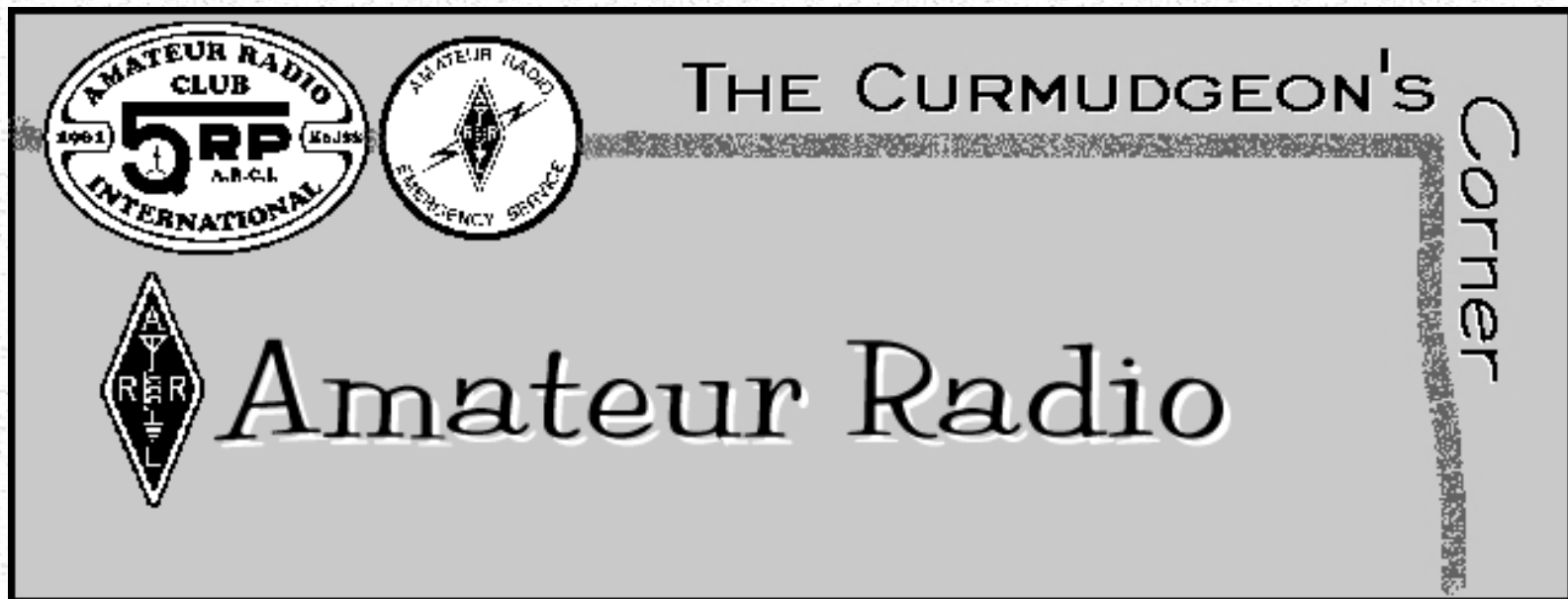

I can be found, as a friend of mine says "putting little dBs into the RF", as Amateur Radio Operator N5NW. [[Click Here to send me email](#)].



[View My Guestbook](#)

[Sign My Guestbook](#)

I used to be KM7W. How does a 7-land call end up in the 4th Call District? Simple -- it's a vanity call, and one of the only ones left that contained my initials. I've held four call signs in my time, N4UYT (bad on CW and Sideband), KN4BH (bad on CW!) and KM7W ("you're not from around here, are you boy?" -- HA HA!). Had my old call been better on Morse Code, I would have kept it and not bothered with the vanity stuff.

But, since getting interested in Low Power (QRP) operation, I needed a shorter, more "CW-friendly" call sign.

The current station consists of an Icom IC-706MkIIG for VHF and UHF, and a Kenwood TS-570D(G) for HF. Antenna is an off-center fed doublet, vertical dual band (2m/440), a 2m Squalo, and a 6m Horizontal loop. I'm hopeful to get a beam up in a year or so. I have a CMOS III SuperKeyer, Kent paddles, Vibroplex Brass Racer paddles and the Envirotronic 501G paddle through the computer). I've also got a CMOS II SuperKeyer for backup.

Past stations have consisted of homebuilt tuners and power supplies, a Sierra multi-band QRP rig, and a complete Kenwood TS-430s with MARS modifications. Former rigs include a Kenwood TS-570D(G), a couple of Kenwood TS-940sat, and an Icom 706MkIIG. I was the Net Manager (callsign NNNØGBU-3) for [Tennessee Navy/Marine Corps MARS](#). My personal Navy MARS call (officially a NAVMARCORMARS STA) was NNNØRBB. I also have owned a [TenTec](#) Argonaut 556 (nicknamed the "Cubbie", because it is a low-power version of the Ten Tec Scout), a homebuilt 38 Special (one of the NorCal Projects), and various VHF rigs, with an MFJ-1278 multi-mode

controller.

The Antenna Farm used to consist of one parallel dipole for the 40 and 30 meter bands. It is made of 450 ohm twinlead, and only requires 100 feet of the stuff for four band construction! E-mail me for details, or check the ARRL Handbook, available from the [American Radio Relay League](#), a national Ham Radio organization. Now, I just have some wire around! You can find more detail on the [antenna page](#). This page also has information on my favorite compact antenna, the Distributed Capacitance Twisted Loop, or DCTL.



I'm a member of the [Tennessee Contest Group](#). I'm currently classified as a pop gun, although I hope to make it up to little pistol some day. My idea for a club QSL card:

K4TCG

Tennessee Contest Group Club Station

Confirms 2-way contact with:

| | | | |
|------------|------|------|----------|
| Station | | Date | |
| | | Mo | Day Year |
| Time (UTC) | Mode | Band | RS(T) |
| | | | |

Operating from _____ (City) _____ (County), Tennessee

The font is Eros Bold ITC @ 34 point for the callsign and 14 point for the text below the line. Other text is in Arial 8 point, except in the confirmation block where 7 point Arial is used.

I'm a member of the [QRP Amateur Radio Club International](#) (#7514), the [Internet QRP Club](#) (#953), the [Alaska QRP Club](#) (#098), and the [Northern California QRP Club](#) (#2031). Click on the Club Names to go to their pages -- links for ham radio are abundant elsewhere, and I don't want to bore anyone with another page full of cross-links.

Tennessee Special License Plate application for Amateur Radio. Click on [this link](#). Takes a while to load ... be patient.

The FOR SALE and WANTED TO TRADE/BUY section

I have:

two Heathkit wattmeters/SWR meters (2kW)

Return to [The Curmudgeon's Corner](#) (Note: This link leaves this domain to my family page)

[Click Here to send me email] .

This page, and all original graphics, © 1999, 2000, and 2002 Martin D. Watt.

Antenna tech page

New antennas, simulations, antennas related projects and information.

The DDRR antenna designed by Dr. Boyer for Northrop

The DDRR (Direct driven ring radiator) was invented by Dr. Boyer from Northrop, for military applications in the 50s. It stayed classified until Dr Boyer published an article titled "Hula hoops antennas" in Electronics (Jan 11, 1963). "73 Magazine" published also a two part article from Dr. Boyer titled "Surprising Miniature low band antenna". The article is quite technical and contains a very precise mathematical formulation of the DDRR based on transmission line theory.

In layman's terms a DDRR is just a short vertical monopole (vertical post) attached to a transmission line tuned by a reactance (ring plus vacuum capacitor). The reactance of the capacitor is transformed by the transmission line and will under specific conditions (length, value of the capacitor, etc.) make the vertical post resonant. Slight variations of the capacitor will lengthen or make the transmission line "shorter" and allow tuning of the antenna on a certain range.

First lets make a difference between the DDRRs patented by Dr Boyer and the ones that we can find here and there in amateur publications. Boyer designed two basic models: the one ring DDRR and the two rings DDRR.



The first one is made of an opened ring made of aluminum tubing (4 in.) over the perfect ground of a metallic structure like a warship, and with two aluminium posts connected at the extremities of the ring. A set of fiberglass post supports the ring. One of the vertical post is attached at the base by the coax, the other one contains a variable vacuum capacitor to tune the antenna. This faded picture from the 50s from Northrop show a set of concentric DDRR for 2 to 30Mhz. The engineer is standing below the 75m loop (6 feet height) and is looking at a 50Kv vacuum capacitor. This type of DDRR was installed on some special communication and ELINT warships,

and was apparently used in the early stages of the Apollo project.

Contrary to most ham publications, Dr Boyer in all the articles he wrote, and in his discussions with VE2DLJ and VE2AMT stressed the importance of using big fat aluminium or copper tubes and to avoid at all cost chicken wire as ground plane. **In a one ring DDRR he insisted on the fact that you needed a solid metallic ground plane.**

The advantages of DDRR compared to a vertical are obvious, especially on a ship. Small size and height, remotely tunable, low noise due to loop structure, extremely low impedance and therefore no or little influence on connected electronic equipment from voltage transients and lightning. Low angle for long range communication and possibility of a secondary high angle for NVIS, indispensable in fleet communications, can be achieved by using a configuration using a central post and two posts with vacuum

capacitors.

The second type is a double ring system isolated from the ground with the same two vertical posts connecting the opened extremities of the rings. One is solid aluminium, the other one contains a Vacuum. A third aluminium post cut in the middle is used to feed the antenna and can be moved to adjust the SWR. The coax enter in the middle of the right post, then up then down to the "feed point" where the shield is connected to the top part and the center of the coax to the bottom part of the post. This configuration creates a coaxial balun for a symmetrical attack. Matching is achieved by moving the "feed point post".

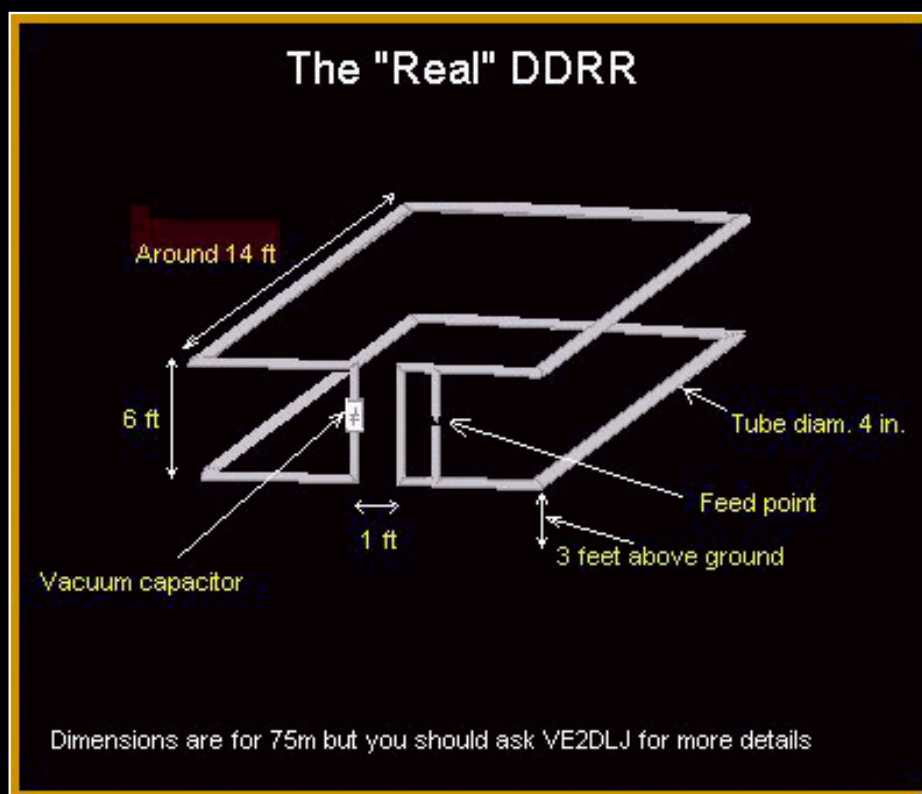

The antenna is standing and supported by very high quality isolating posts made of PVC or fiber glass, and Dr Boyer even recommended beehive isolators at the extremities of the posts to limit losses. The whole structure is placed some 3 feet above the ground.

Contrary to the one ring model, there is no need here for a perfect ground and Dr Boyer was confident that this antenna could perform well even on very poor ground. He referred in his articles to the fact that DDRR are essentially "magnetic" antennas in the near-field and that losses in the ground by magnetic field are negligible. This is not entirely true and computer simulations and experiments by VE2DLJ showed that even if losses in the ground are negligible there is an improvement when radials are inserted.

Tests made by Boyer and his team for Northrop and the US Navy showed that the antenna was very low noise and very low angle. This was done in side to side comparisons made with a collapsible vertical on 160m in the Arizona desert, using a half square mile ground plane made of solid copper sheets soldered together (visible in the picture).

VE2DLJ and VE2AMT found some ten years ago an old copy of the 73 Magazine article and decided to build a prototype. They contacted Dr. Boyer and have numerous discussions with him. He warned them and told them "not to cut corners". His recommendations were:

- Use big tubing: 4 inches or more for 75m.
- Do not use automotive exhaust pipe. It will rust and contacts losses will transform the antenna into a dummy load.
- All contacts and connections must be A1. Solder corners if you make it square, use Penetrox everywhere.
- Use very high voltage vacuum capacitors, and high quality isolators to support the rings.
- No chicken wire. Dr Boyer was horrified by some description of DDRRs using chicken wire. He explained that measurements made by Northrop engineers showed that the near field is in concentric rings on a one

ring DDRR and that chicken wire could add losses.

Our two explorers decided to build the antenna following scrupulously all recommendations. Some years ago, Alex, VE2AMT, made a square DDRR for 75m, with special machined metal brackets in the corners so that it could be disassembled if necessary. He adjusted it and worked two VK and a ZL the first day he used it on the air using 100W. He explained that listening on this antenna was a real experience. He could hear no noise at all and the DX was Q5 all the time, even when other stations couldn't copy the DX. The antenna was at that time sitting on the side of his house on wooden blocks 2 feet above the ground.

VE2DLJ followed suit a few years later and his DDRRs are visible in the [Picture page](#). He is very often in the 75m DX window working VK, ZLs and other pacific stations.

Models

NEC4WIN Model

```

CM ***** 80m DDRR *****
CM
CM   Designed by JM Boyer for Northrop
CM   Supposed to be Low Noise, DX antenna
CM   VE2DLJ, Tony Cicchetti, is using a full size
CM   version for 80m and can be heard in the DX Window
CM
CM   US Patent #RD26196, RE 3,151,328 Northrop Corporation
CM   "Hula-hoop antennas", Electronics, Jan 11 1963, Boyer.

CE
GND Reference
UNITS Feet
Height 0.88
Over Ground 14 6 (Diel. - Cond. µSiemens)
Circular Boundary
F 3.790
GW 1 3 0.000 0.000 0.000 6.000 0.000 0.000 0.500
GW 2 3 7.000 0.000 0.000 14.200 0.000 0.000 0.500
GW 3 5 14.200 0.000 0.000 14.200 14.200 0.000 0.500
GW 4 5 14.200 14.200 0.000 0.000 14.200 0.000 0.500
GW 5 5 0.000 14.200 0.000 0.000 0.000 0.000 0.500
GW 6 3 0.000 0.000 6.000 6.000 0.000 6.000 0.500
GW 7 3 7.000 0.000 6.000 14.200 0.000 6.000 0.500
GW 8 5 14.200 0.000 6.000 14.200 14.200 6.000 0.500
GW 9 5 14.200 14.200 6.000 0.000 14.200 6.000 0.500
GW 10 5 0.000 14.200 6.000 0.000 0.000 6.000 0.500
GW 11 4 6.000 0.000 0.000 6.000 0.000 6.000 0.500
GW 12 4 7.000 0.000 0.000 7.000 0.000 6.000 0.500
S 1 48 100 0
LC 1 43 0 41.8
Coax 1

```

NEC4WIN95 Beta v1.00.5 Log File

DDRR.N4W

Antenna Height is : 0.26 meters

Ground Diel. = 14 Cond. = 6 μ Siemens

Frequency = 3.790 Mhz

Wave Length = 79.103 Meters

Load # 1 = 0.000E+00 +j -1.005E+03 at Pulse 43

Impedance = 0.46 - j 0.08 Ohms at Source 1

SWR = 2.19 with 1 Ohm Coax

DDRR.N4W Zenith

Antenna Height is : 0.26 meters

Ground Diel. = 14 Cond. = 6

Z1 = 0.46 - j 0.08 (2.19)

Height = 0.268 m

Max = 1.13 dBi <----- NO RADIALS

Lobe at : 152° (BW:48°)

Lobe at : 28° (BW:50°)

DDRR.N4W Zenith

Antenna Height is : 0.26 meters

Ground Diel. = 13 Cond. = 5

40 Radials of 65.6168 feet

Z1 = 0.46 - j 0.08 (2.19)

Height = 0.268 m

Max = 4.47 dBi <---- 40 radials of 66 feet

Lobe at : 170° (BW:44°)

Lobe at : 10° (BW:44°)

DDRR.N4W Zenith

0 dB = 4.47 dBi

Frequency = 3.790 Mhz
Antenna Height is : 0.26 meters
Ground Diel. = 13 Cond. = 5
40 Radials of 65.6168 feet
Z1 = 0.46 - j 0.08 (2.19)
Height = 0.268 m
Max = 4.47 dBi
Lobe at : 170° (BW:44°)
Lobe at : 10° (BW:44°)

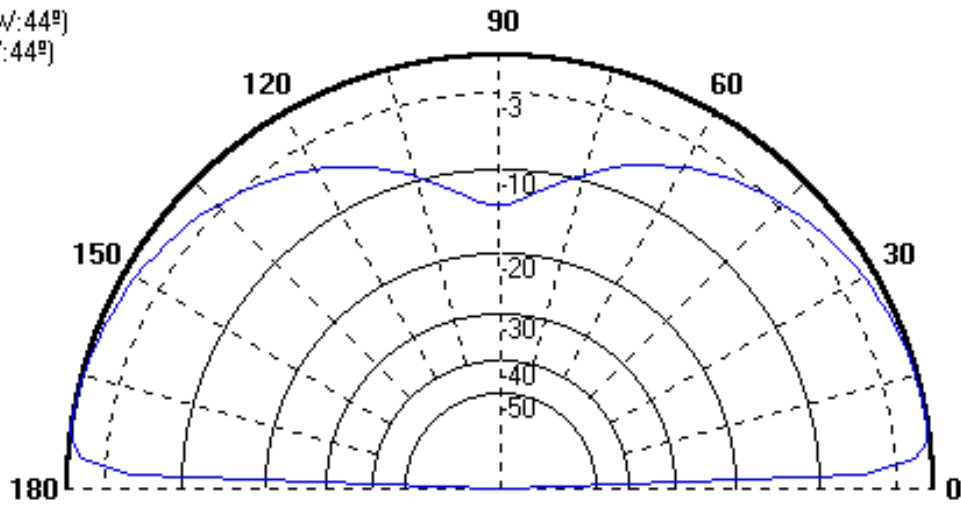
**DDRR with 40 radials**

DDRR.N4W Azimuth

Frequency = 3.790 Mhz
 Antenna Height is : 0.26 meters
 Ground Diel. = 13 Cond. = 5
 40 Radials of 65.6168 feet
 $Z1 = 0.46 - j0.08$ (2.19)
 Height = 0.268 m
 Max = 4.49 dBi
 F/B = 0.09 dB

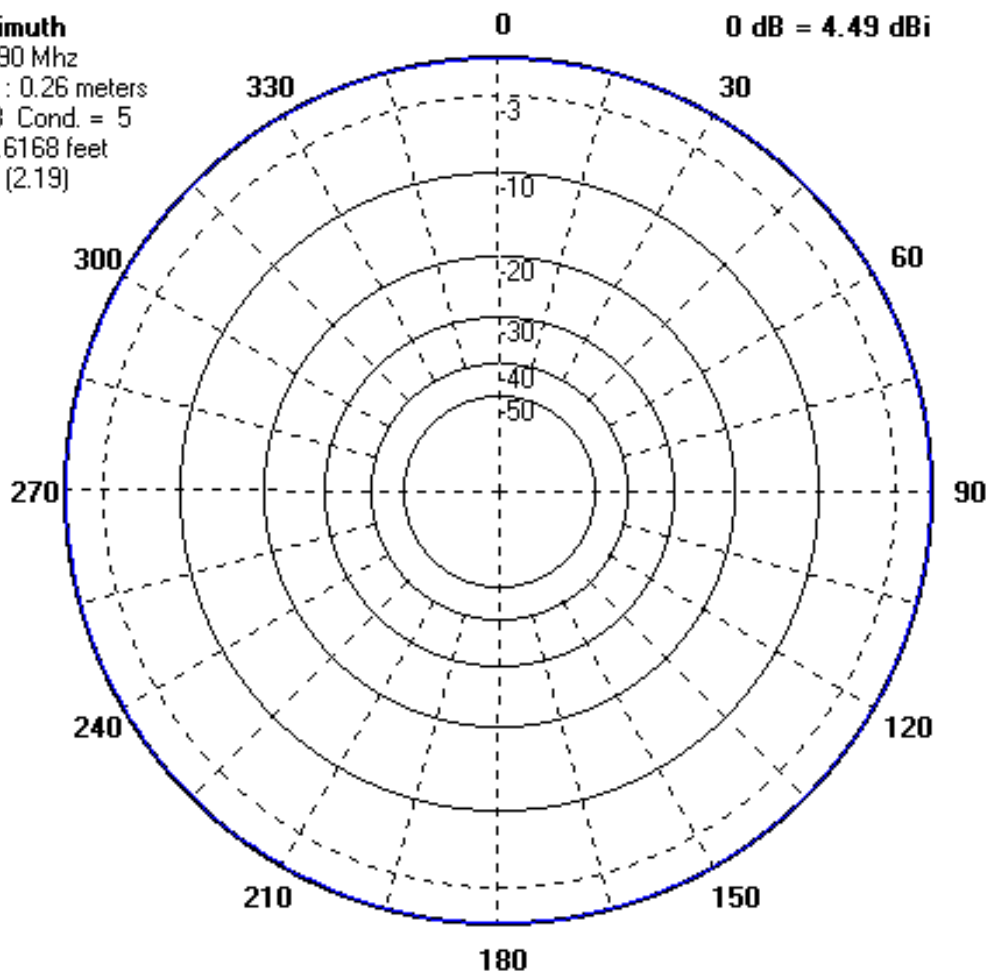

DDRR with 40 radials

AO Model

DDRR for 80m

Ground 13 5

1 zone 50 radials #12

13 5 0 100

3.795 MHz

10 aluminium wire, feet

```

10 0 0 3 14 0 3 0.3
10 14 0 3 14 14 3 0.300
10 14 14 3 0 14 3 0.300
10 0 14 3 0 1 3 0.300
10 0 0 9 14 0 9 0.300
10 14 0 9 14 14 9 0.300
10 14 14 9 0 14 9 0.300
10 0 14 9 0 1 9 0.300
10 0 0 3 0 0 9 0.300
10 0 1 3 0 1 9 0.300
    
```

1 source
wire 9, center

1 load
wire 10, center 10 pF

ANALYSIS

Impedance 0.678 -j 18.7 Ohms
SWR 84.01

Wire Losses 0.33 dB
Efficiency 92.6%

At 18.0° Elevation:

Forward Gain 3.41 dBi
F/B -0.34 dB

Maximum Gain 3.81 dBi at 132° Azimuth
Radiation Peak 164° Elevation (3.77 dBi gain)

**DDRR with radials vs a Dipole at
130 feet DDRR is better at low angle
(<18 deg)**

80DIP
DDRR

Over Ground
Ground

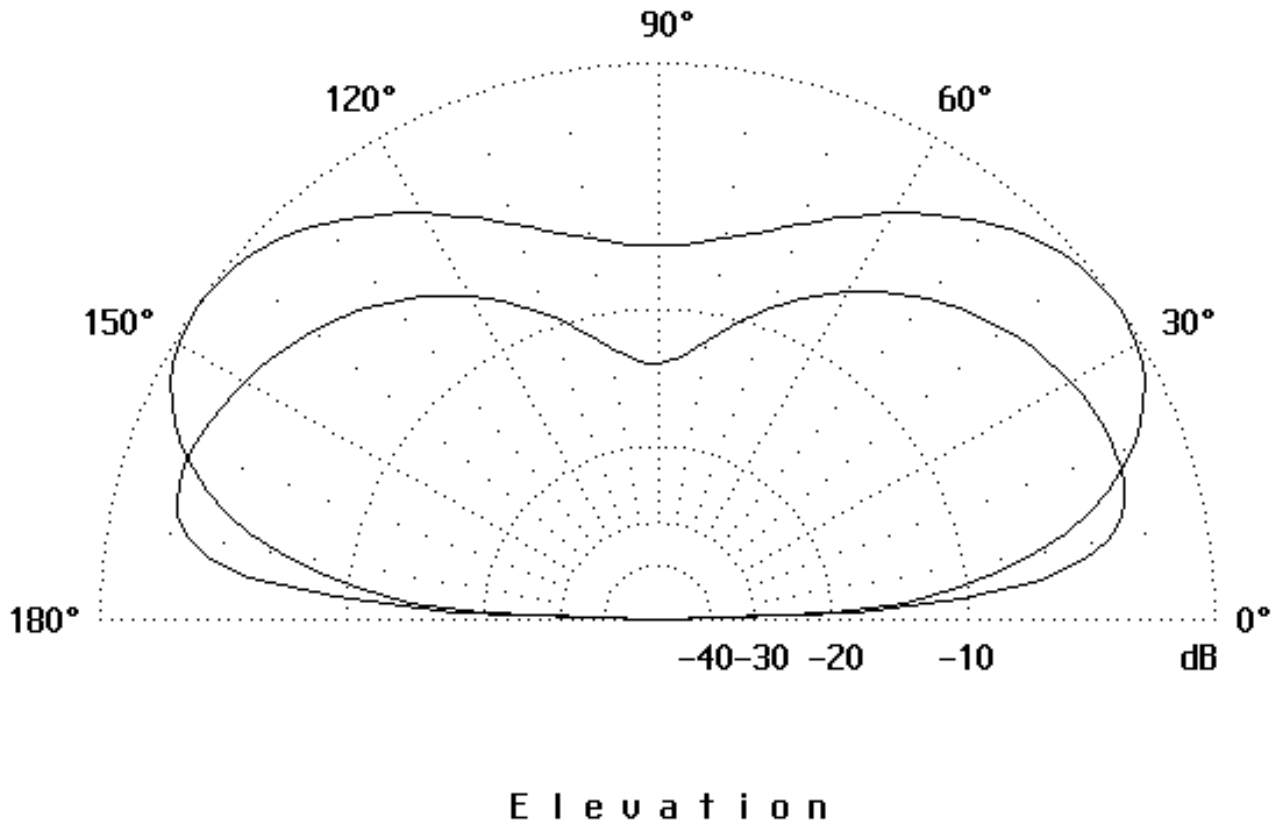

0 dB = 5.71 dBi

3.795 MHz

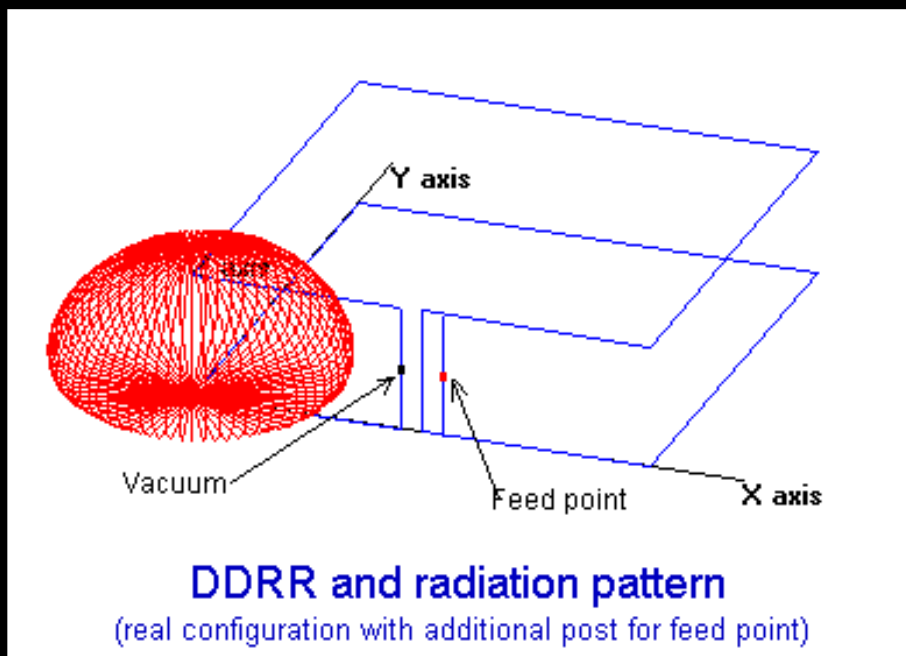

Comments and remarks

The DDRR impedance is very very low. At 0.5 ohms, any wire or connection losses will transform the antenna into a dummy load. This is why one needs big fat tubes. Losses in the tuning capacitor must be minimized too and a vacuum of very high voltage is indispensable.

Contrary to Dr Boyer's predictions, **the addition of radials increased gain and lowered radiation angle.** This was confirmed by VE2DLJ experiment's. We see from the zenith patterns that the TOA is below 20 degrees and that the antenna is a low angle radiator. **This could be OK for long range DX like VK and ZLs but it is not very good for medium range DX.** This was confirmed by long term testing over a year and a half period. Tony, VE2DLJ, has a horizontal loop "reference antenna" and the loop will always beat the DDRR toward Europe in transmission even in Winter. The horizontal loop will also give better reports (in average) than DDRR on long range DX *outside of Winter DX period* but starting around beginning of October the DDRR will start beating on average, the horizontal loop by one to two S units in transmission on VK, ZLs and JAs.

In reception, the DDRR (according to Tony, and most hams who listened on them) will always beat the loop for QRN and man made QRM. Signals will be sometimes one to two S units lower but always perfectly Q5. The bandwidth is some 20 to 30Khz and the Q is in the 300 to 400 range, so the antenna is very selective which is a big advantage.

We can see from the comparison of a **dipole at 130 feet vs the 3 feet high DDRR** that the DDRR is better on low angle signals. The difference is even more important for a lower dipole.

What are the advantages of the DDRR? Low noise antenna, low angle. "Small size" requiring little real estate. Could be easily installed in a backyard at ground level or on a flat roof. No tower needed, no climbing. Immune to noise, static electricity and lightning. Tunable, very high Q. Boy that seems great!

Does that mean that I will "recommend" a DDRR? Hell No! To build a good system you need some 100 feet of 4 in. tubing, then solder the corners (or use special machined brackets) to reduce losses. If you want to transmit full legal power you need 50 KV vacuums, and they are not cheap. Add the cost of good isolators to support the rings etc and you end up with a two to three thousand dollars antenna. Even if ground does not influence much the DDRR in the near field, ground is important for the first reflection and you need good ground around the antenna. If you have neighbours the low angle may create TVI. Another major point is directivity. The DDRR doughnut is omnidirectional and to work DX you need directional antennas. That's the only way to eliminate QRM and concentrate the energy in one direction. This means that one DDRR is not enough and you will need at least two.

To build low band DDRRs, there are cheaper alternatives using salvaged Heliac. Three or four VE2 designed DDRRs using plumbing copper tube, wire and Heliac with variable success. The only area where price/performance is interesting, is in VHF/UHF. At these frequencies, DDRRs are easy to build and very small. Otherwise, stay away from them unless you know what you are doing.

Madjid
VE2GMI

Patents: US Patent (J.M. Boyer) #3,151,329; #3,247,715; RD26196 all assigned to Northrop Corporation

Note: Tony, VE2DLJ can be found in the 75 DX window on most mornings, sometimes evenings at sunrise and sunset.

DDRR2 Article

If you have questions, comments, critics, suggestions click here: art@orionmicro.com
Copyright (C) 1997 - 2001 VE2GMI

First the Dipole...

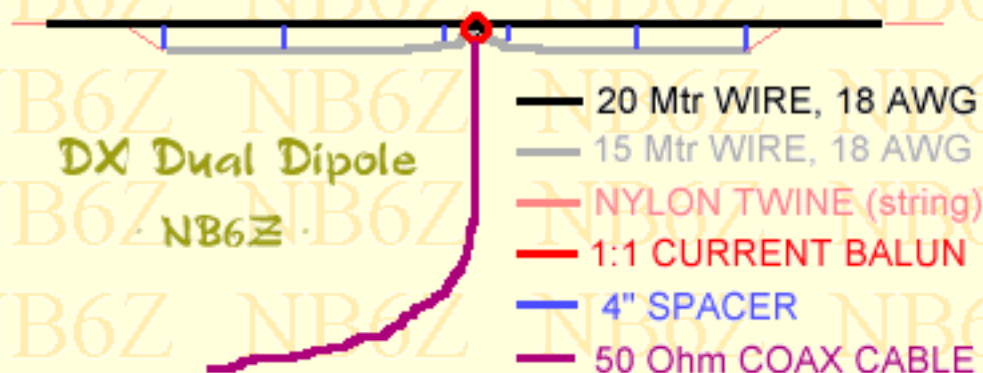

The antenna diagram you see before you is nothing more than two dipoles fed from the same coaxial line. I call it a "DX Dual Dipole" because it is cut for two very useful DXing ham bands. There is no harmonic relationship between 20 and 15 meters, and so they "play" well together when

sharing the same transmission line. The wire length cutting chart for HF ham band dipoles is found in any antenna handbook. (The half wave dipole cutting formula is: Length in feet = 468 divided by the Frequency in Mhz.) Both dipoles are cut per the chart (or formula) to the low end of each band, leaving a little extra wire length for SWR tuning. Construct the dual dipole using the techniques described for the [NB6Zep Antenna](#) and make the wire spacers from plastic coat hangers as described there. Follow the instructions in the handbooks to make a 1:1 current type balun device using a small toroid core. (The smaller T130 red HF material cores work fine for several hundred watts.) The use of a balun is not strictly necessary for the dual dipole, but it is strongly advised if you are going to add a parasitic element (reflector) as described later. If your feed point is not supported, as was the case for me, you will want to use a strong stranded wire (#20 thru #12 AWG) and light weight coax.

Here is a **HOT TIP** for light weight and portable operation. Use short runs of RG-174 coax for low power operation at HF frequencies. I tested 30 feet of this very small coax at 50 watts before beginning construction and found no objectionable loss or leakage at 14 Mhz. (Do not use this coax at power levels greater than 100 watts or with antennas that require a tuner!) Another advantage with RG-174 is you can make a current balun (coax choke) simply by wrapping 10 turns of the coax around a T150 toroid core at the end of the cable where you attach it to the wires. I have been using this cable successfully for several years...

To tune the antenna, each dipole must be trimmed separately by cutting small equal length pieces from each end until a low SWR (below 1.5 to 1) is achieved for the low end of the band. (You may tune them to the desired frequency if you do not intend to add a parasitic element later.) This can be done with the antenna at six feet off the ground, but expect the SWR to change slightly when you bring the antenna to full elevation. (Always listen for a clear frequency before testing SWR. SWR tuning is not needed for receive only operation.) There will be interaction between the two dipoles, so alternate between dipoles until you find the right match. (Note: Yes you can add additional half wave elements for other HF bands to this configuration. Adjusting multiple elements for a low SWR becomes problematic and will take some patience. I recommend a multi band wire with tuner such as the NB6Zep.)

...then the Yagi.

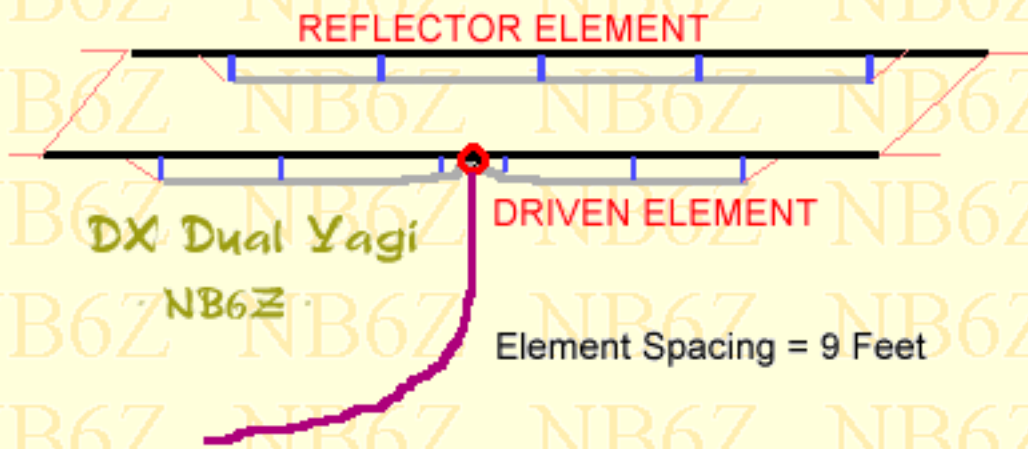

The two element yagi style antenna I am most comfortable with is one that employs a reflector instead of a director element. The yagi I chose to build has a parasitic reflector nine feet behind each dipole. (Nine feet was a compromise for dual band operation.) My computer modeling

looked good with standard reflector lengths, so I cut the reflector wire lengths to what I found in the antenna handbooks for 2 element yagis. You should have reasonable results if you cut the wires to 5% greater than the dipole length (dipole x 1.05) for each band. When the reflector is in place behind the driven element as shown, you should notice a slight change in the SWR. This is due to mutual inductance as the reflector is inducing power from the driven element. The effect is to lower the impedance of the driven element. If you trimmed the dipole SWR for the low end of the band as previously instructed, you may find the resonance is now in the middle of the band. However, you may need to do some final trimming on both driven elements to compensate and make a better match at the transmitter side of the coax. When you are satisfied with the SWR on both bands, raise your yagi as high as possible and free from large objects and other tuned antennas.

I have my dual yagi at 30 feet above the back yard and pointed at 33 degrees towards Western Europe from Beaverton, Oregon. A major challenge was to figure a way to support the yagi in the direction I wanted it to operate. I used two trees supporting an existing 15 meter EDZep wire and used a third tree to triangulate enough nylon twine to create the configuration shown. My Dual Band Yagi has been in place, with zero maintenance needed, for over two years... A closer view shows more detail of the wire spacers, (note the NB6Zep at 40 feet).

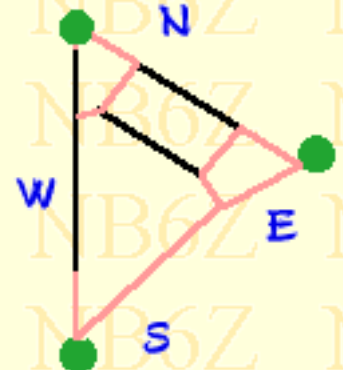

Basic Performance: The antenna modeling was done with all the wires in the yard included in the model to get the whole story of how well this antenna should do for me. First on 20 meters...

[CLICK for DETAIL](#). Slightly better results is predicted for 15 meters... [CLICK for DETAIL](#). Needless to say, after seeing these predictions, I was excited about building and testing this antenna!

Comparison testing has shown that the gain from the yagi is close to what the model predicted. Granted, it is impossible to measure a 3.6 dB gain while operating under skip conditions, but the yagi out performed all wires I tested it against. The Front to Back ratio is a bit hard to confirm from

Oregon; but I note that my 15 meter EDZep used on 20 meters always works better to the South Pacific than does the yagi. The differences between the yagi and the NB6Zep (SE and NW) on 20 meters is typically greater than 20 dB for skip conditions. The beam width is noticeably broader on the yagi than on the NB6Zep and I can use it for contacts to the NE sections of the USA.

With the yagi antenna I am able to work any European station I hear on 20/15 meter CW, MFSK16 or Hellschreiber mode with 50 watts. 😊 I can hear good PSK31 sigs from over the pole, but still have a hard time decoding them here in the North West. 😞

Would you rather use a tuner instead of manually trimming each dipole? The [Super Zep](#) antenna is a more "elegant" solution for a multi-band wire beam.



"Push-button Menu of Stuff"

Rotatable, Self Supporting Dipoles

KQ6RH

(C) 1998, 1999, 2000

Ray Jurgens

(Up-Dated 2/25/2000)

Rotatable Dipoles:

There are quite a few ways to make full-sized dipoles that can be rotated. How you attack this mostly depends upon what band is to be covered (basically how big) and whether the wire is to be horizontal or is permitted to slope downward from a central post. In the horizontal case, the wire is threaded through the spreaders and may extend out the ends. The ¼" tubes have an adequate ID that #16 wire is easily passed through the tube, so extenders can be added to the usual fiberglass ½" tubes that fit the hub. In doing this, you should be aware that the velocity factor will be less than unity, so the physical size of the dipole will be slightly smaller than that of free space. In order to make connections to the feed line at the hub, two ¼" diameter holes have to be drilled at an outward slant into two opposite spreader sockets. These should be drilled at about a 45 degree slant beginning about ½" out from the center. A ten meter dipole requires no extenders. Longer wavelengths require extenders, and the 20 meter dipole may require wire extending slightly beyond the extended spreaders. In general, feed the wire through the extender first, then into the ½" tubing, then slide the extender into the half inch tubing and push the wire beyond the end of the spreader about 4". Feed the wire into the hub and up through the access holes that you drilled. Then push the spreader into the hub. Now, from the tip of the spreader pull the wire until there remains just enough wire at the hub to make the connections to the feeder. Adjust the length of the spreader extenders, and tighten the hose clamps. Leave about a foot of extra wire beyond the extender. You will then need to trim this to get proper resonance once the structure is in the air. In the case of ten meters, you are done, simply mount the hub on the mast and put it up. No guy lines are needed if you don't mind a bit of droop. In the case of 20 meters, there is much more to do. Here, the length of the spreader will be about 15' if you have a 1' overlap with the extender. So you will need a central guy post 6' long, i.e., use a full 8' section of 1" tubing with 2' below the hub. You will need guys to both the inner spreader at 8' and the outer extender at 15' up to the central hub for both spreaders. You also may need rotational stability if you want this to settle down after rotation or gusts of wind. The two unused socket holes are there for a reason, so, fit two 6' or 8' (if you have room) ½" spreaders in these sockets and guy them in the same manner as before at the 8' and 15' locations. Always set the guys from the inside first, then add the outer ones. This is still a fairly

loose structure since only gravity holds it in the downward direction. If this structure is still not stiff enough, you can guy downward to the mast as well. The limiting tension is set by the point where the extenders begin to buckle. That turns out not to be a whole lot of tension, because a 7' section of the ¼" tubing sets the limit.

The second procedure is to make an inverted V dipole, where the antenna is the upper guy lines from the center pole out to the spreader tips. For the ten meter case, this is nearly identical to the ground/counterpoise discussed in the [Quick Vertical](#) section. In that case, there are no extenders, so the construction is very simple. In the 20 meter case, all the same problems are encountered as above except that the wire load is acting as the upper guy lines rather than being in the spreaders. We also suggest using light wire for the 20 meter version. In fact, # 18 or # 20 hook-up wire works well, and the insulation should be left on. We prefer the un-tinned type that is commonly available at Radio Shack. Using, the 6' center pole, the length to the tip should be just about correct, however, the insulation slightly reduces the velocity factor, so you can shorten the extender or use a small length of Nylon fish line to extend the wire.

Note, the 17 and 20 meter versions of these dipoles are fairly large structures and can not be built up in small spaces. They are also rather flimsy, and go through lots of distortion when being tipped up. These are better erected from a push-up mast with the rotator near the top of the mast. This Dipole antenna gives the same gain as all other dipoles, however, the Half Square is a much better DX antenna for a given elevation and may be worth the extra effort. All parts used for the construction of the dipole can be used to construct the Half Square, so there is no loss in investment if you decide to switch. Note that 6 and 10 meters require no extenders, but we do recommend that you use guys from the tips to the center post. The post should extend about 3' above the hub.

Parts required for all 6 and 10 meters versions:

| Item | Quantity | Description |
|------|----------|---|
| 1 | 1 | HUB 4-050-100, Central Quad Hub (RFJ) |
| 2 | 2 | 8' 1/2" OD fiberglass tubing, spreaders (MGS) |
| 3 | 1 | 8' 1" OD fiberglass tubing, boom (MGS) |
| 4 | 2 | GT 4-050 1/2" Guy Ties, for tips of spreaders (RFJ) |
| 5 | 2 | GT 4-100 1" Guy Ties, for tips of boom (RFJ) |

Extenders are required for 12 , 15, and 20 meters. To determine how much 1/4" fiberglass to buy, you need to calculate the approximate length required for the dipole. If the wire is to be inside the fiberglass, the velocity factor is slightly less than 90%. The size of a typical dipole is given approximately by $468/f\text{MHz}$. This formula has a small correction factor for finite wire diameter and end effects. When the wire is inside the fiberglass tubing, the appropriate factor is about $435/f\text{MHz}$, so the lengths of the spreaders require for 12, 15, 17, and 20 meters is roughly as 8.72', 10.25', 12.02', and 15.33'. Assuming 6" overlap and 8' lengths of 1/2" OD spreaders, the extenders will have to be 1.22', 2.75', 4.52', and 7.83'. Obviously, there is no compelling reason to cut the 8' of 1/4" OD tubing for the 20 meter spreaders. You can get both a 15 and 17 meter extender out of a single 8' length of tubing. 15, 17 and 20 meters require lateral guys to increase the stability. This requires two 4' lengths of 1/2" OD tubing inserted in the two remaining sockets. Guys should be run to the tips of both the 8' dipole tips and the extended tips. This is also true from the central Guy post. The guys can be either 50 lb. test Nylon fishing line or Kevlar thread. The photos associated with the [Half Square](#) antenna show structures built with both fiberglass and PVC.

[Return to Main Menu](#)

Notes on the Terminated Wide-Band "Folded Dipole"

L. B. Cebik, W4RNL

As space for antennas continues to shrink in the present era of smaller urban and suburban yard, hams have begun to turn to 1-antenna solutions to their operating needs. Among the choices for a horizontal antenna that operates on all of the HF amateur bands, the wide-band "folded dipole" (WBFD) has been gaining popularity. I thought that it might be useful to do some comparative studies using this antenna as a base-line.

The basic WBFD looks something like **Fig. 1**.

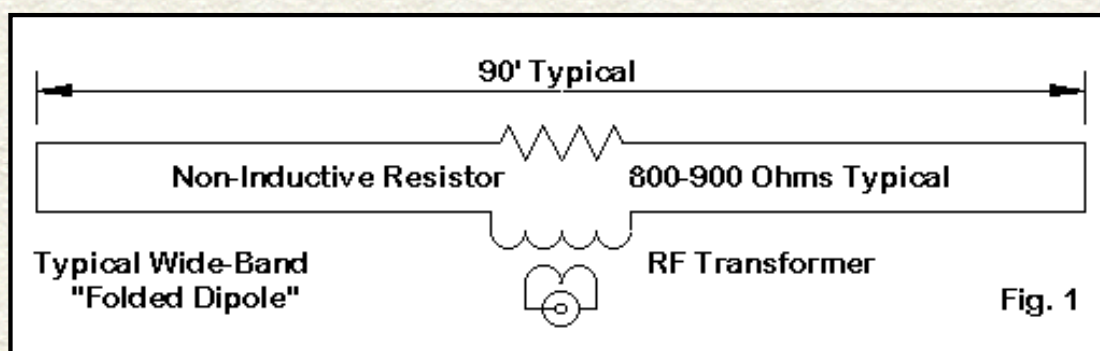

The antenna design appears to be a folded dipole. However, a folded dipole is a resonant antenna, while the WBFD is designed to operate with a low feedpoint impedance across a wide range of frequencies. Moreover, the WBFD contains a non-inductive terminating resistor usually located at the point in the loop directly opposite the feedpoint. Normally, the resistor is in the 800-900 Ohm range. This impedance is roughly replicated at the feedpoint. Therefore, builders install a 16:1 RF transformer (either of transmission-line transformer or normal transformer design) at the feedpoint. The result is a low SWR value for 50-Ohm coaxial cable across the entire frequency range.

For receiving use, such as in SWL service, the terminating resistor can be a low wattage carbon type. For transmitting service, the resistor must have a power value capable of dissipating a fair share of the applied power. The exact amount will vary with frequency, but commercial versions of the antenna are often rated for reduced power at the low end of the operating range, where power dissipation is highest.

Commonly, WBFD antennas are offered in a 90 to 100 foot length (27-28 meters) for service between 2 and 30 MHz. However, one can build WBFD antennas in almost any length. Only the effective operating range of frequencies will change.

Since we may also construct doublets of the same length and feed them with parallel transmission line to an antenna tuner, it seemed fair to compare the gain of such a doublet with that of a WBFD of the same length across the 2-30 MHz range. The model I chose for the WBFD is 27.2 m (89.25') long, with the wires separated 0.2 m (7.8"). The terminating resistor is 820 Ohms, a standard value used in some commercial models. The wire is #14 AWG. The doublet is a simple length of #14 copper wire exactly as long as the WBFD.

27.2 Meter Wide Band FD vs. Doublet Free-Space Gain

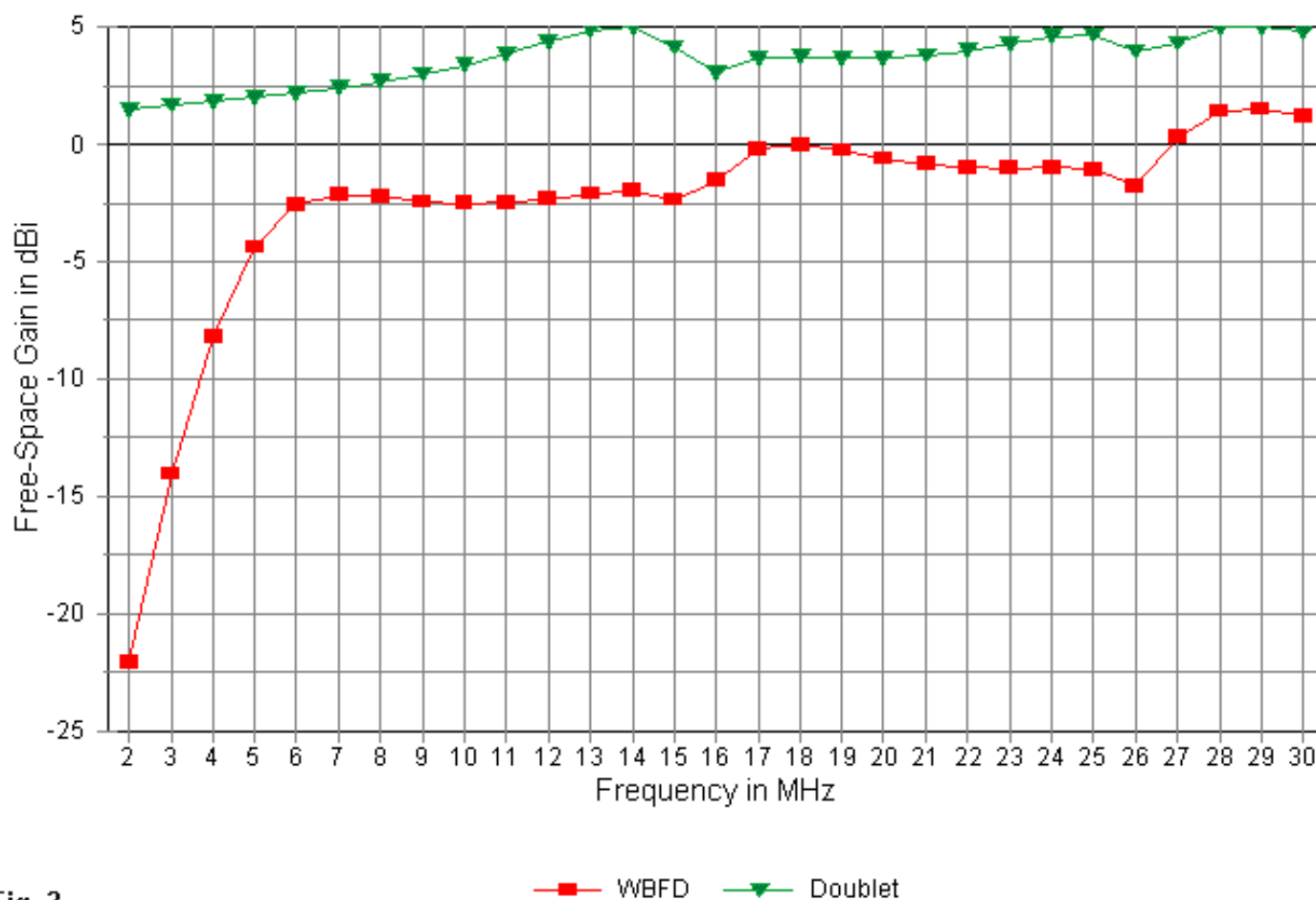

Fig. 2

—■— WBFD —▼— Doublet

Fig. 2 compares the free-space gain of the two antennas at 1 MHz intervals from 2 to 30 MHz. Since the elevation angle of maximum radiation will be the same for both antennas for any height above ground and for any ground conditions, any differences that show up in the free-space model will also show up in actual antennas at any height above ground.

Several instructive notes emerge from the comparison of gain in **Fig. 2**. First, the overall average difference in gain between the two antennas is nearly 6.3 dB, with the advantage going to the doublet. If we neglect frequencies below 7 MHz, the average difference diminishes to 5.0 dB. For most of the range of use of the WBFD, then, there is about a 1 S-unit deficit in gain relative to a standard doublet of the same length in the same position.

Second, the WBFD gain curve displays a significant knee--a frequency below which its gain deteriorates rapidly. In the case of the current model, that frequency is about 6 MHz. At or below the knee-frequency, the terminating resistor dissipates more and more of the power. The result is not only a large decrease in gain and higher temperature stresses on the resistor, but as well, very low SWR values at the feedpoint. The knee-effect as the WBFD becomes significantly short relative to the length of a resonant dipole easily accounts for the need to derate the antenna relative to transmitting power below a certain frequency.

The deficit in gain is not necessarily a disadvantage for receiving purposes. Modern receivers tend to be equipped with receiving pre-amplifiers that the user can switch in as desired. The gain may range from 10 to 20 dB, depending upon design, and in some receivers may be stepped or variable. Therefore the gain deficit can be largely made up in the

lower HF range. Moreover, the basic receiver, apart from preamplification, already has excess gain that is rarely used in the lower HF region.

In addition, one of the major problems in reception in the lower HF range, especially with respect to SW broadcast stations, is front-end overload from excessive signal strength. The overload also tends to produce spurious products within the receiver. Hence, reduced gain of the antenna can be in some circumstances an advantage rather than a disadvantage. Combined with the RF attenuator built into many receivers--which may be a single reduction value or stepped--the Wbfd offers a potential for excellent lower HF reception, free of some of the problems that occur with higher gain antennas.

Because the Wbfd is also a closed loop with a terminating resistor, many users claim quieter reception relative to doublets for a given receiver input signal strength. The degree to which this is both true and separable from the freedom from front-end overload is difficult to determine. Nonetheless, SWLs have found the Wbfd a very useful tool for their efforts.

In order to establish that the Wbfd has the same pattern as a doublet of the same length for any given frequency and height above ground, let's look at a couple of sample free-space patterns. For example, see Fig. 3.

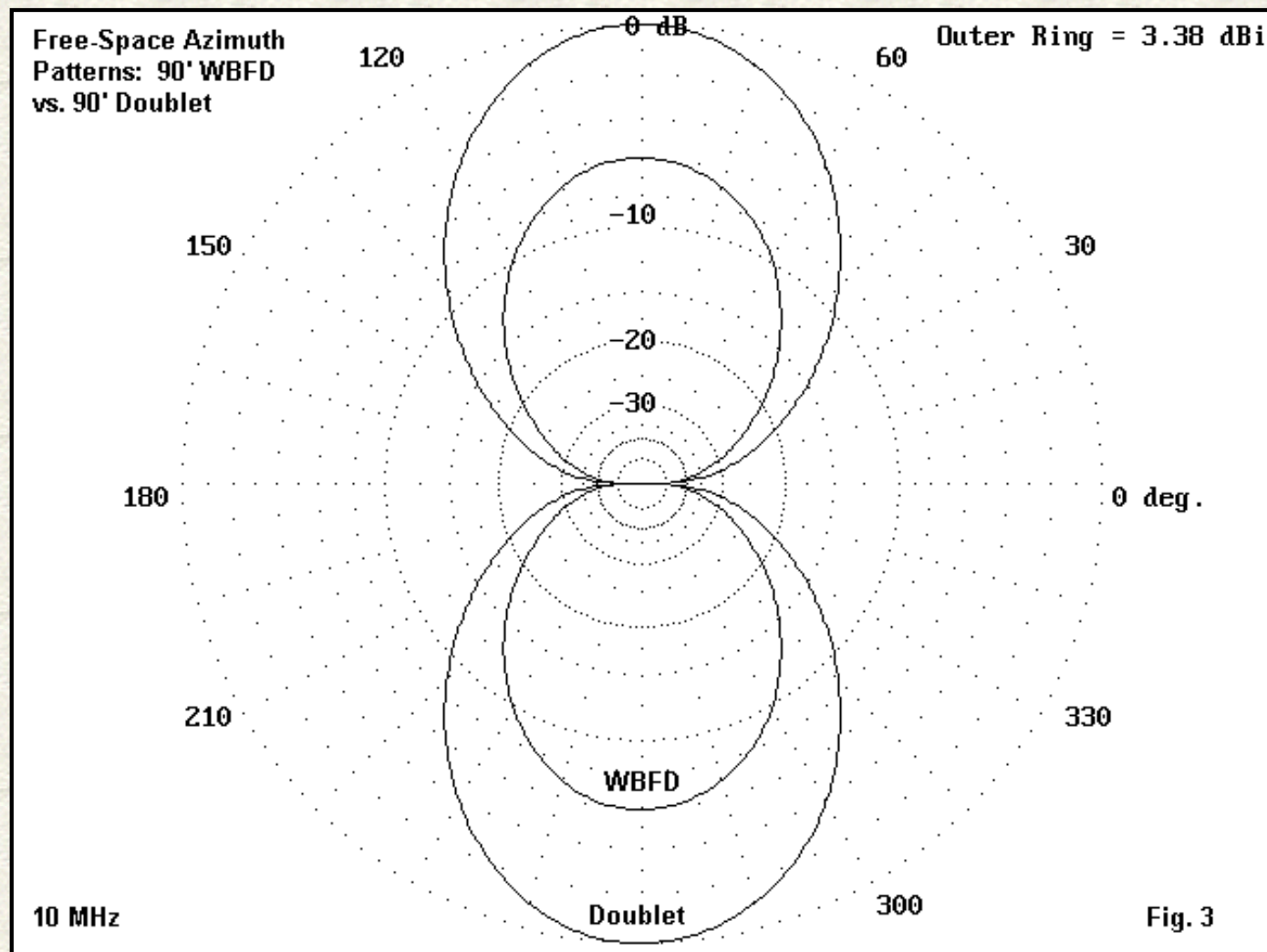

The 27.2 meter Wbfd and its comparison doublet exhibit a bi-directional pattern at 10 MHz. The shape of the pattern is identical, with only the 6 dB gain differential separating the two antennas. The -3 dB beamwidth points are also virtually identical. Since the take-off angle (elevation angle of maximum radiation), the reflection from a given set of ground conditions, and other such factors are not dependent upon signal strength, the two antennas would also show elevation patterns for any equal antenna height that are likewise congruent.

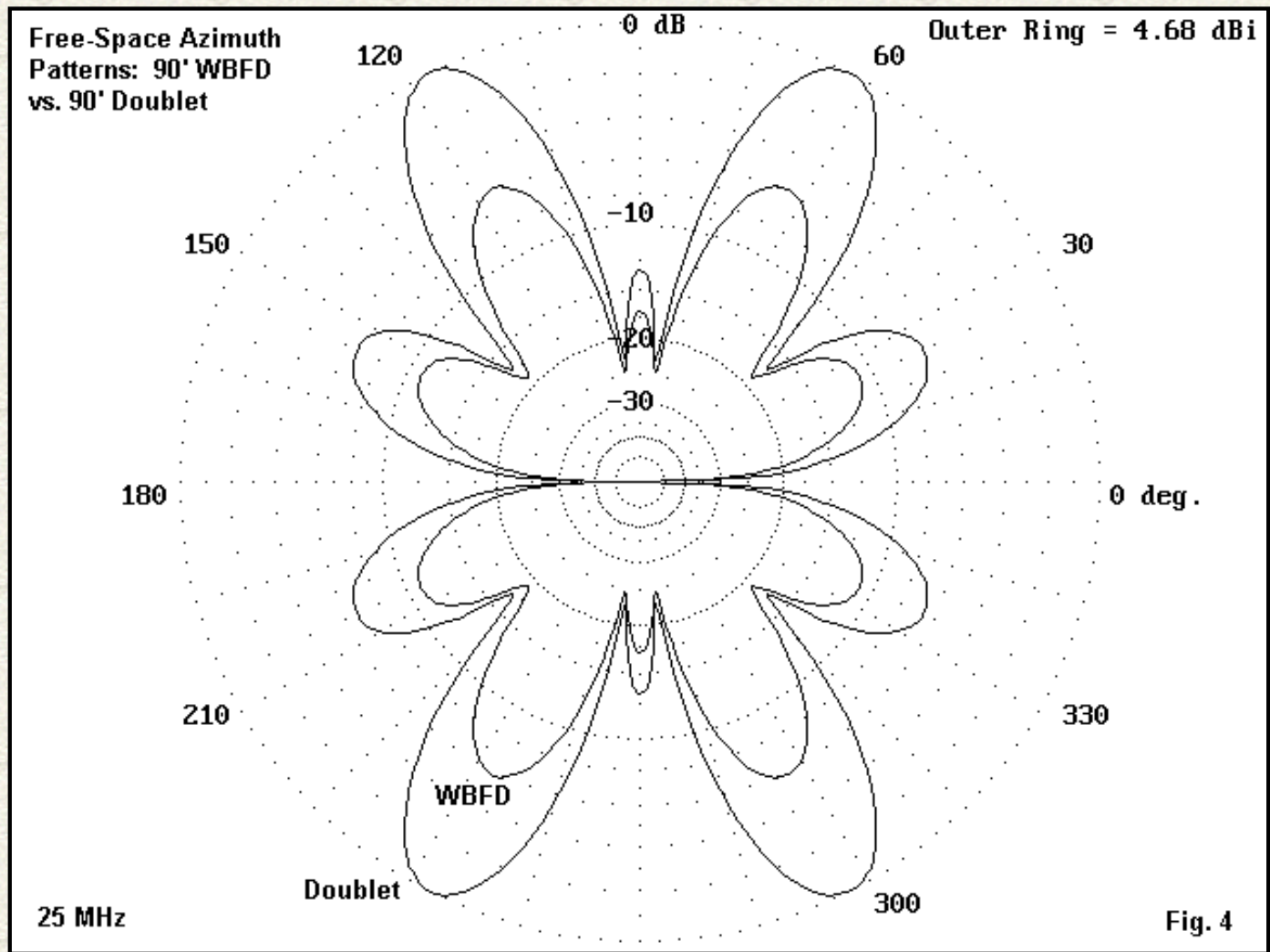

Fig. 4 shows comparative free-space azimuth patterns for the two antennas at 25 MHz. The WBFD pattern is simply a "mini" version of the doublet pattern, with about a 6 dB difference in strength.

There is an additional point in displaying these patterns. The exact pattern of lobes and nulls in the azimuth readings for a WBFD is identical to that of a doublet. As the length of the antenna exceeds 1.25λ and approaches 1.5λ , the bi-directional pattern at lower frequencies will break up into a collection of lobes and a collection of nulls. Therefore, the antenna is variably selective in its favored directions of good signal strength as one changes frequency. Those who contemplate installing either a doublet or a WBFD antenna need to consider well the patterns at key frequencies of interest in order to orient the antenna for maximum effectiveness.

The antenna type has also been used vertically to provide omnidirectional coverage. However, in this orientation, when the antenna exceeds 1.25λ in over length, the pattern begins to show primarily high angle radiation--exactly the opposite of what one normally desires from the upper HF band. As a result, some installations may use a pair of vertical WBFDs for full low-angle HF coverage.

A Note on Knees and Length

The knee we observed in the gain of the 27.2 meter WBFD is interesting, since it suggests that we may vary the low frequency gain by changing the length of the antenna. Changing the length, of course, will also change the frequency at which the antenna changes from a bi-directional pattern into a multi-lobed pattern.

To examine this question, I recreated the 27.2-m antenna model to perform frequency sweeps on both longer and

shorter versions. As a sample, I ran a 50-m version and a 15-m version. All of the models used 820-Ohm terminating resistors, #14 AWG copper wire, and a spacing of 0.2 meters.

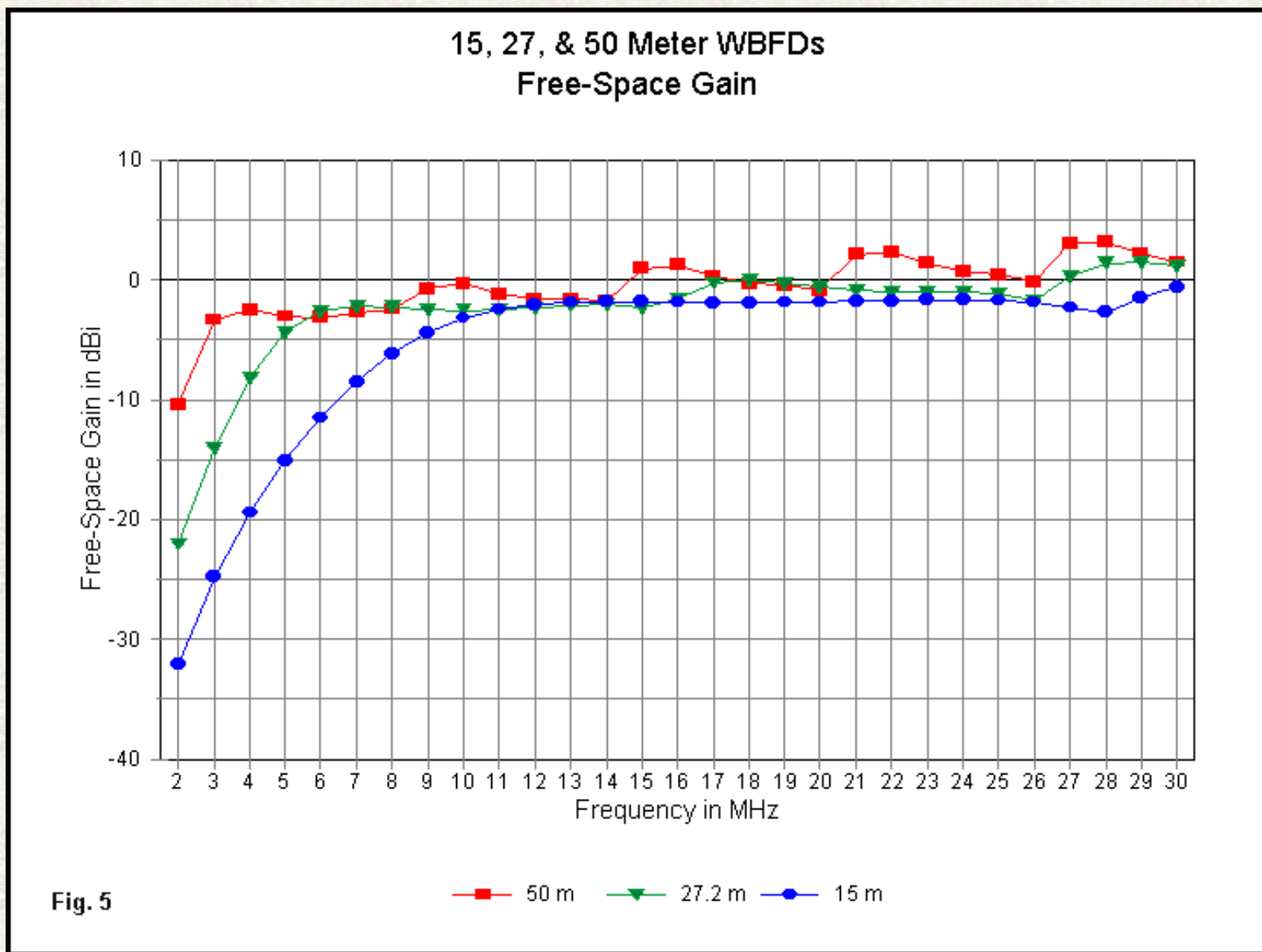

Fig. 5 compares the gain of the three antennas from 2 through 30 MHz in 1 MHz steps. As suspected, the 50-m antenna reduces the knee frequency to about 3 MHz. In contrast, the 15-m version increases the knee frequency to about 10 MHz. In general, a home builder may interpolate values for the knee frequency for other lengths in the overall range.

The longest of the antenna models shows a mere -10 dBi gain at 2 MHz, a value easily made up by the receiver and only about 1.5 to 2 S-units below the average gain of the antenna. Hence, it is likely to be more satisfactory as a transmitting antenna in the lower HF region. In contrast, the 2 MHz performance of the 15-m version is more than 30 dB lower than the average antenna performance, making it more suitable for higher HF transmitting.

The variations in gain among the curves in the relatively flat region of performance are a function of lobe formation. Maximum gain tends to attach to the major lobes of patterns taken at just higher than integral multiple of a wavelength, relative to antenna length. Minimum gain levels tend to be associated with antenna lengths near the "x+.5" wl (where x is an integer) points. When an antenna is 1.5, 2.5, 3.5, etc. wavelengths long, its pattern consists of a combination of emerging and disappearing lobes, all of relatively equal strength. For example, a 1 wl wire has 2 strong lobes that are 180 degrees apart and a 2 wl wire has 4 strong lobes that are roughly 90 degrees apart. A 1.5 wl wire has 6 lobes, as

the 1 wl lobes diminish and the 2 wl lobes grow. Hence, coverage is wide, but at a reduction in maximum strength.

The number of peaks and valleys in the three gain curves is a function of length. The 50-m antenna passes through many more transitions from x wl to $x.5$ wl (where x is an integer) across the frequency span than do either of the shorter antennas. Hence, we should expect more highs and lows in the gain pattern.

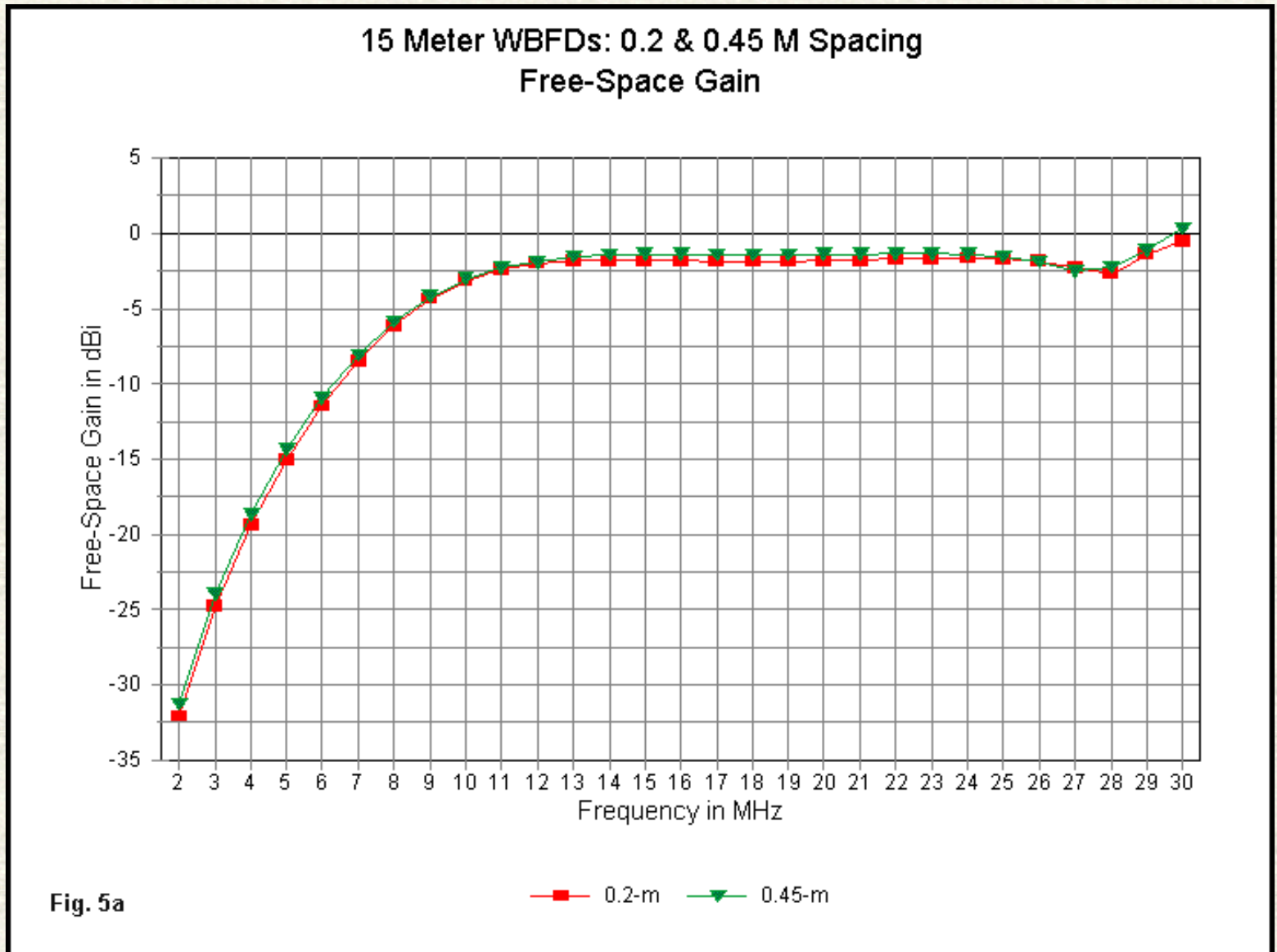

One question posed by various recommended wire spacings in past literature is whether wire spacing makes a difference to performance. **Fig. 5a** provides something of an answer as it compares the gain values for models of a 15-meter long version in 0.2-m and 0.45-m spacing. The gain values are insignificantly different, ranging from 0.2 to 0.4 dB.

15, 27, & 50 Meter WBFDs VSWR

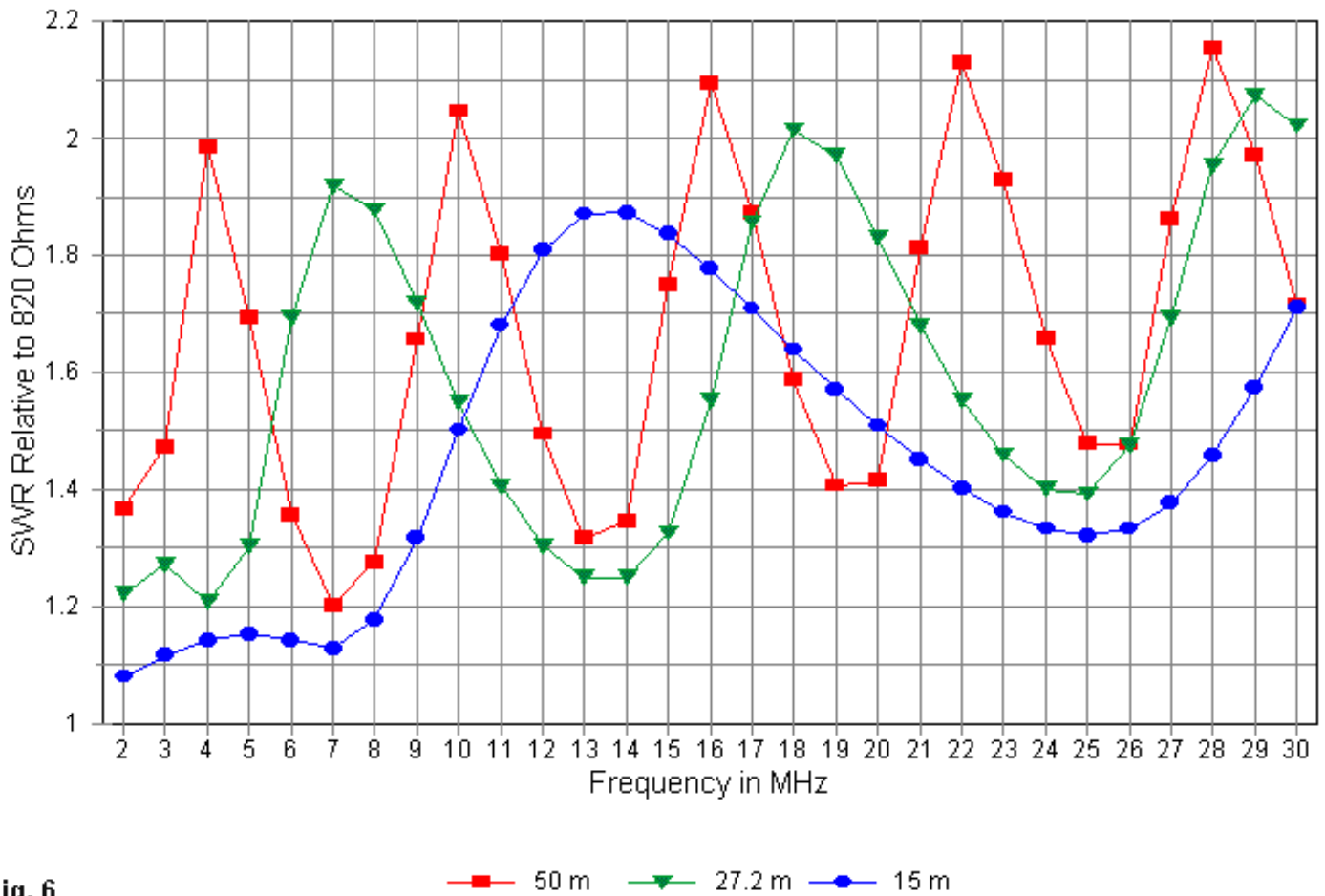

Fig. 6

■ 50 m
 ▼ 27.2 m
 ● 15 m

We find that the curve of SWR relative to the value of the terminating resistor will also show similar transitions according to WBFD antenna length. **Fig. 6** shows the SWR pattern for the three antenna models. If we look at the most dramatic fluctuations--in the case of the 50-m antenna, we discover SWR peaks at $x+2/3$ wl points (where x is an integer). In contrast, we find SWR minimum values at the $x+1/6$ wl points (where x is an integer). The frequency span between points relative to the antenna length is $1/2$ wl. The shorter antennas show the same pattern. However, the pattern is less evident because there are fewer maximum and minimum values to sample.

We may also note that the longer the WBFD, the higher the SWR excursions for a given value of terminating resistor. However, if we examine the lowest values of minimum SWR and exclude the region below the gain knee of the curve, the corresponding low points in the curve show the longest antenna also to exhibit the lowest minimum value of SWR. In other words, for a given wire size, spacing, and terminating resistor, longer WBFDs will exhibit a larger range within any given SWR cycle. As we approach the upper HF range, the values may exceed the desired 2:1 SWR limit.

The amount by which a long WBFD exceeds a 2:1 SWR is not great, but it is noticeable. For receiving applications, mild excursions beyond the 2:1 limit have virtually no affect on the received signal strength for any length of 50-Ohm coax. Some transmitters use automatic power reduction circuitry as the SWR approaches 2:1 (using an internal reverse voltage sensor), and some linear amplifiers begin reducing power at lower levels of SWR in order to protect expensive transmitting tubes.

There are two means of overcoming the potential problems of "high" SWR. Some manufacturers recommend the use

of very long coaxial cables. Since the losses in the line increase with frequency, the SWR observed at the station end of the line will be lower at higher HF frequencies than at lower HF frequencies for any given value of SWR at the antenna end of the cable. The result of using longer coaxial cable runs will then be an SWR curve at the transmitter output that never exceeds 2:1. Compared to the reduced gain already inherent in WBFD design, the added losses of a long cable run are not considered excessive when totalling the overall system gain.

Alternatively, modern amateur transceivers (and those in other services) are routinely (but not universally) equipped with automatic antenna tuner circuitry. Although limited in range compared to a wide-range external antenna tuner, these tuners are certainly adequate to handle the modest SWR values presented by even the longest WBFDs. Hence, the transmitter output circuitry prior to the tuner will show a very low SWR.

Construction

The decision to use a WBFD involves an evaluation of one's goals in operating or listening. Only with a set of specifications of this order can one decide whether the WBFD will meet the needs. The description of the antenna's advantages and limitations must be set against the operating specifications and along side other potential antennas that are candidates. Then selection becomes a matter of choosing the antenna that does most of the jobs well enough.

If you do decide to use a WBFD, you can purchase one of the commercially made types. B&W (USA), Giovannini (Italy), and others produce these antennas in a variety of lengths. Alternatively, you can build your own.

The antenna proper uses standard techniques of wide-spaced folded dipole construction. You will need twice the length of wire as you determine the antenna length to be. There is nothing critical about the exact length, although the general length will be a function of where you decide to place the frequency that forms the knee separating relative even performance at higher frequencies from diminishing gain at lower frequencies.

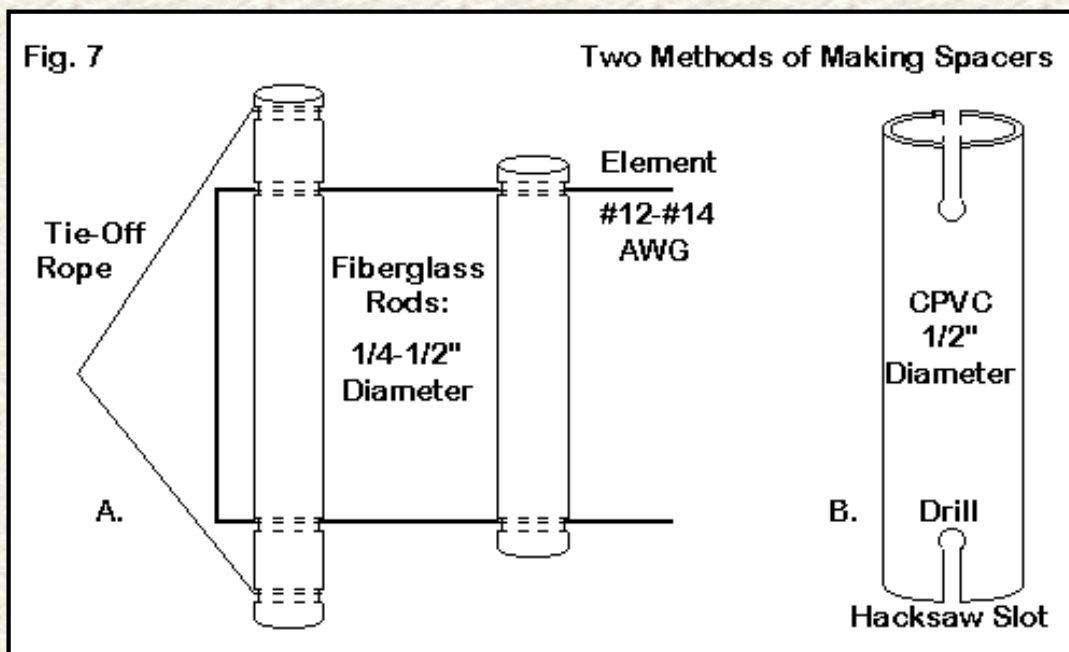

Fig. 7 shows just 2 of many ways to space the wires along their length. In the 1930s, we might have used wood dowels boiled in paraffin. Today, we have access to a variety of better materials. Part A of the sketches shows fiberglass rods, with holes drilled to pass the size wire we decide to use. #12 to #14 AWG copper wire (0.06-0.08" or 1.5-2.0 mm) is likely to be the most common choice. The end post can be longer to hold tie-off ropes for the assembly. Fiberglass rods can be purchased from mail order sources. However, local home improvement centers often carry adaptable materials. For example, I recently spotted some 1/2" diameter fiberglass rod under the guise of chimney flue brush extension handles.

Alternatively, I have also had good luck using 1/2" diameter CPVC, a thin-wall form of PVC tubing that replicates copper tubing sizes, shown in Part B of **Fig. 7**. A hacksaw cut in each end leads to a hole drilled to pass the chosen wire size. The wire press fits down the slot and into the hole. If the holes are not deburred, the wires stay put, although the spacers can be repositioned with fair ease.

These are simply two of many ways to make the required spacers. Narrow strips of polycarbonate, acrylic, or plexiglass would also work. Polycarbonate likely has the best UV resistance of this group. When adapting materials to a new use and environment, it is wise to check the structure every so often to ensure that it is wearing well under the influence of sunlight, precipitation, and temperature excursions. Of course, cut any spacers that you use to the desired length--about 8" (0.2 m) between wire holes for the models examined here. However, this spacing is not very critical.

Locating a non-inductive resistor of sufficient power dissipation is likely to be the chief problem for Wbfd builders who intend to transmit with the antenna. Unless you can find a suitable resistor at one of the surplus outlets, purchasing an antenna may prove economical in the long run, if we add both cost and parts-searching time together. Any value in the 800-900 Ohm range--or even "thereabouts," if a bargain appears--will serve.

Manufacturers use different methods of packaging the resistor into the antenna assembly. Some prefer a total enclosure to weather-proof and bug-proof the resistor. However, one might have to derate the resistor's power handling capability under these circumstances. To maximize power dissipation, the resistor can be placed within a tube that is about twice the diameter and about 1.5 times the resistor's length. Air passing through the tube provides cooling, while the tube itself protects against immediate weather impacts. Since the antenna wire and resistor terminals will attach to strips of metal bonded to the tube, the resistor itself is relieved of strain. The down side of this technique is the need to clean out bugs and others debris on a regular basis. However, semi-annual inspection and antenna maintenance is always a good policy.

For receiving-only applications, the resistor problem is much simplified. A series-parallel combination of carbon resistors with a net value of about 820 Ohms is easy to arrange. 1 to 5 watt non-inductive resistors provide the sturdiest construction. The assembly should be mounted in a UV-resistant plastic housing with strong terminals for connecting the antenna wires.

The other challenging component is the 16:1 RF transformer. The builder has two general types of transformers to use: a transmission-line transformer or a standard wide-bandwidth transformer using a toroidal core. Transmission-line transformers are slightly more efficient for transmitting purposes, although they prefer purely resistive loads. Jerry Sevick, W2FMI, has written extensively on these units, with instructions on how to build them for many impedance transformation ratios. In a pinch, one might place two 4:1 baluns in series.

There are proponents of standard RF transformers using toroidal cores. Doug DeMaw, W1FB, has written on their use, including calculating the power-handling capability of various cores. For receiving-only applications, small cores can be used, and the basic requirements and calculations are described in recent editions of the *ARRL Handbook*, Chapter 6.

Whatever form of RF transformer you use, package it to withstand weather. A sealed UV-resistant plastic box with a correctly placed "weep" hole for moisture drainage is a good choice. Obviously, you will need connections for the antenna wires as well as a coax connector.

A 3-Wire Version of the Wbfd

The Wbfd has many variations, and from time to time--as I encounter and model them--I shall add a few notes on them. The first addition to the list is a 3-wire WHFD, outlined in **Fig. 8**, with the 2-wire version shown for contrast.

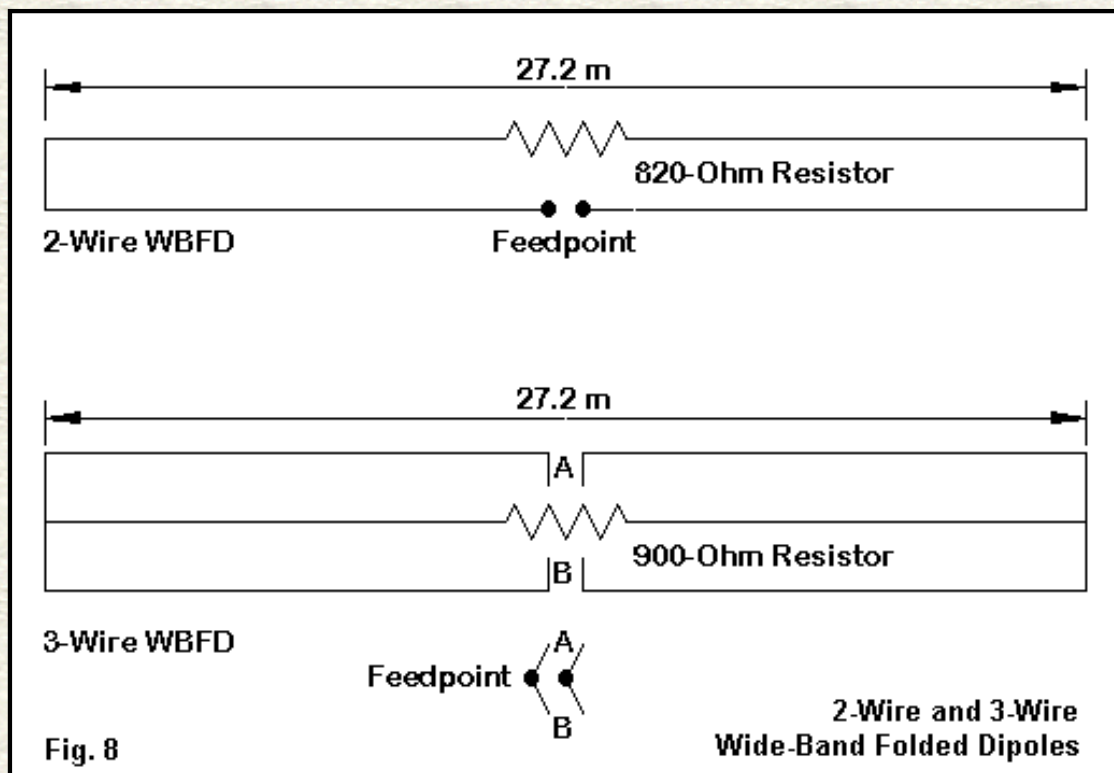

For comparative purposes, I have made each antenna 27.2-m long, with a 0.2-m separation between wires. The 3-wire version places the terminating resistor in the "center" wire and parallel feeds the two "outer" wires. Although the arrangements is shown as a flat configuration, one can, as a variation, create a triangle of wires.

With two parallel-fed wires, the terminating resistor needs to be about 1.5 times the anticipated center feedpoint impedance. Hence, the model uses a 900-Ohm resistor, with 600-Ohms as the expected feedpoint impedance. Of course, the feedpoint impedance is a nominal value, since the actual resistive component of the impedance will fluctuate continuously above and below that value as we move across the operating span.

In general, the 3-wire version of the WBFD is capable of about 1-3 dB (depending upon frequency) gain advantage over the 2-wire version. The following brief table provides a glimpse at the fluctuations for the 27.2-m antennas. All gain values are for free-space.

| Frequency MHz | 2-Wire Gain dBi | 3-Wire Gain dBi | 3-Wire Advantage dB |
|------------------|--------------------|--------------------|------------------------|
| 5 | -4.39 | -1.62 | 2.77 |
| 10 | -2.51 | -1.11 | 1.40 |
| 15 | -2.42 | -0.39 | 2.02 |
| 20 | -0.56 | +0.74 | 1.30 |
| 25 | -1.20 | +0.53 | 1.73 |
| 30 | +1.28 | +2.58 | 1.30 |

Despite these fluctuations, the gain curves for the two versions of the WBFD are remarkable congruent, as shown in **Fig. 9**. The dual or parallel feed system of the 3-wire WBFD increases gain by feeding 2 wires, but it does not change the main characteristics of the antenna. Besides the congruence of gain curves, the patterns yielded by the 3-wire antenna differ from those of the 2-wire version only in peak gain, but not in strength. Since the gain increase is marginal, both antennas have patterns that replicate those of a simple doublet (with its widely varying impedance with changes in frequency), but remain smaller, that is, have much lower peak gain values.

27.2-M 2- & 3-Wire WBFDs Free-Space Gain

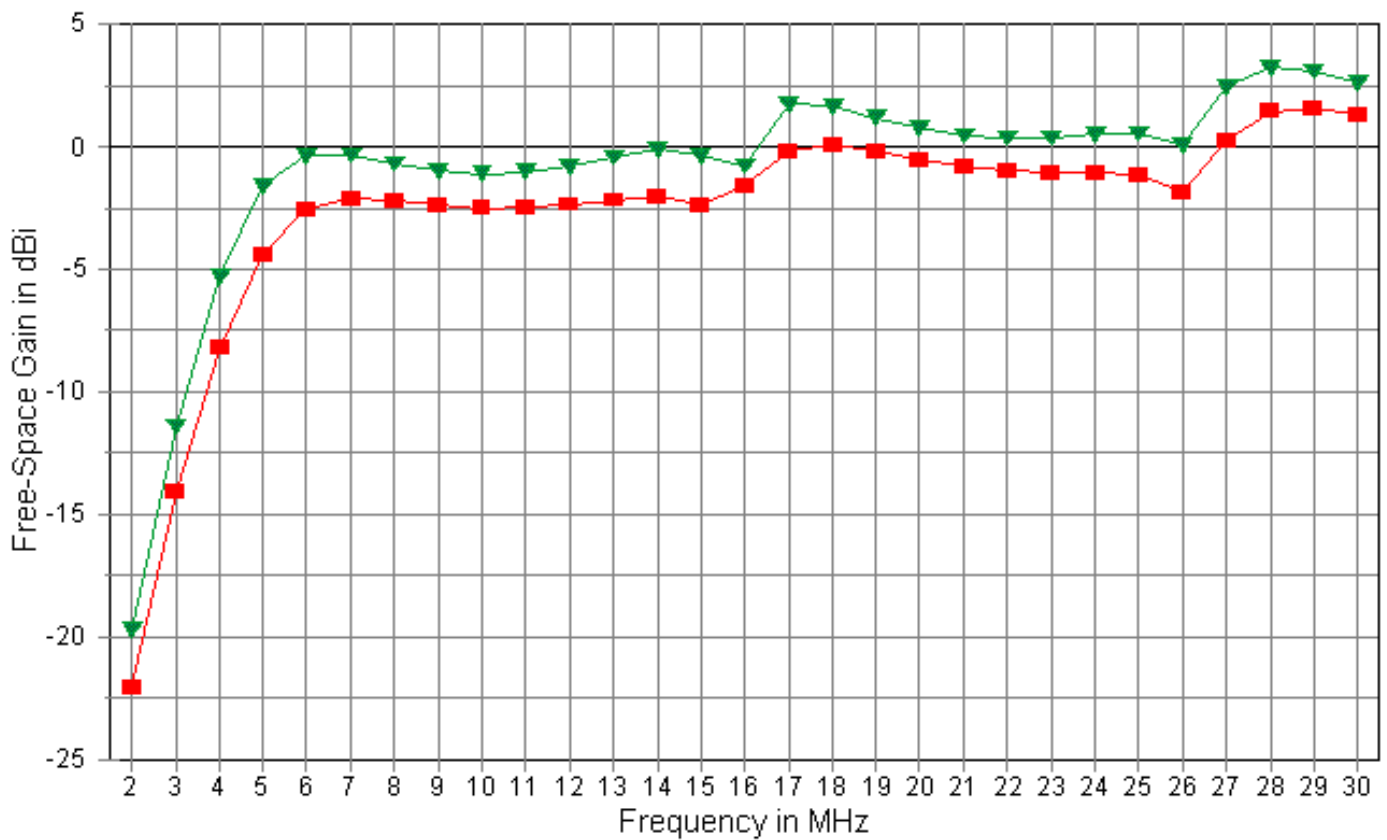
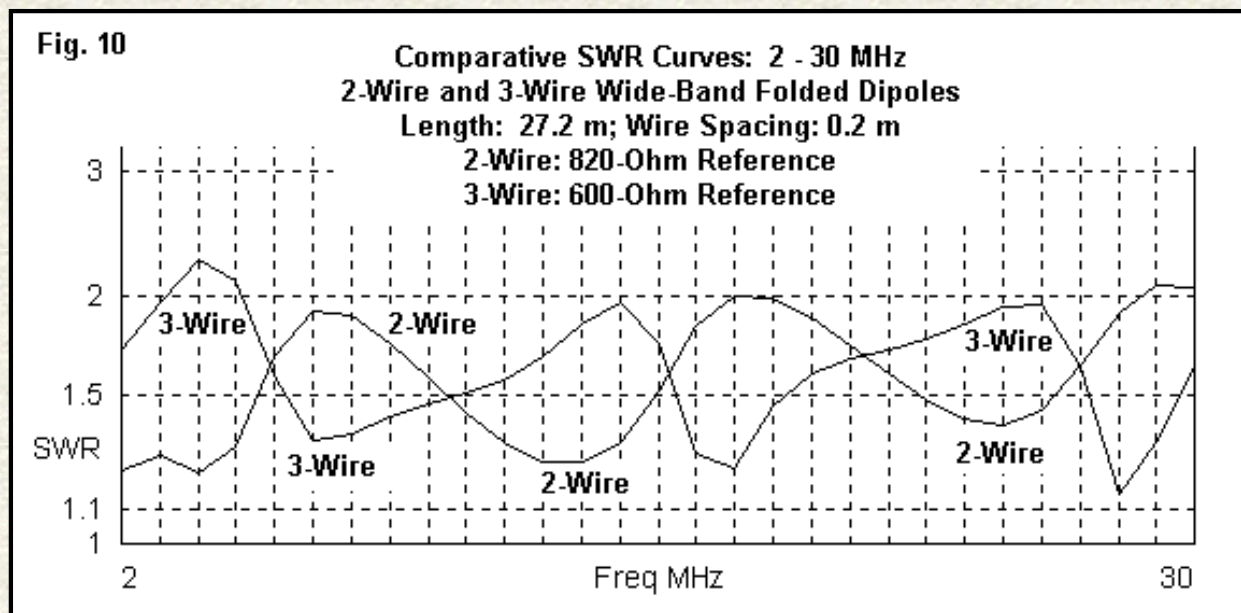

Fig. 9

—■— 2-Wire —▼— 3-Wire

The cost for the small increase in gain is a wider fluctuation in the impedance about a central impedance value. The reactance tends to be somewhat higher than for the 2-wire WBFD. **Fig. 10** shows the comparative SWR curves for the two antennas, with each one using its own reference value: 820 Ohms for the 2-wire version and 600 Ohms for the 3-wire version.



In addition to having higher peak values in the 2-30-MHz span, the 3-wire version curve slopes differ from the corresponding 2-wire slopes. The shallower parts of the curves are on opposite sides of the peaks.

The construction of a 3-wire WBFD can generally follow the same set of techniques used for the 2-wire antenna, with the separators enlarged to handle the broader plane. The additional wire will increase the weight of the antenna proper by nearly 50%, and center support of the terminating resistor and the feedpoint area is advisable. Short sections of 600-Ohm (or thereabouts) open-wire feedline can create the feedpoint junction. Like the 2-wire WBFD, the 3-wire version requires a balun system or a wide-band transformer to match a 50-Ohm coax feedline.

WBFDs can be used in inverted-Vee configurations. However, expect a decrease in the broadside gain and some vertically polarized radiation off the ends of the array--just as you would find in a simple doublet. The steeper the angle of the two side of the antenna, the greater will be the radiation off its ends. As the antenna length exceeds 1 wavelength, the patterns may increasingly differ from those of the antenna used horizontally.

Conclusion

A WBFD antenna is not for everyone. However, gaining some understanding of its operation, its advantages, and its limitations may be useful in the process of choosing an antenna--or even simply learning more about what various antenna types can do. The WBFD has its niche among amateur, governmental/military, and SWL antennas, but that niche is certainly not universal.

Receiving versions of the antenna can be home built for not much more than the cost of the wire, since the materials necessary for low-power terminating resistors and wide-band RF transformers are low. However, building a transmitting version of the antenna at home may be much more problematical, since parts may be hard to find or hard to fabricate. The alternative, of course, is one of the commercial versions, in an exchange of bucks for bother.

Updated 6-1-2000, 7-19-2000, 2-13-2004. © L. B. Cebik, W4RNL. The original item appeared in AntenneX for May, 2000. Data may be used for personal purposes, but may not be reproduced for publication in print or any other medium without permission of the author.



[Go to Main Index](#)

DL7PE

German Amateur-Radio-Station

DARC - C18

Welcome

Sie haben den Weg zu meiner Homepage gefunden, ich freue mich darüber.

Hier finden Sie auch Informationen zu allen DL7PE Kompakt-Antennen.

Bitte wählen Sie nun die Sprache.

it is nice that you are visiting my homepage

here you will find info's regarding all DL7PE compact-antennas

Please select the language.



Sprache Deutsch



English Language

 21392

[FastCounter by LinkExchange](#)

The Extended Double Zepp Dipole

Cut for 15 Meters

Mounted 24 feet high

An extended double zepp antenna for 15 meters is modeled mounted on two 24 foot poles spaced 60 feet apart. The antenna is cut for 15 meters and is 346 inches each side of center. It is feed in the center with 300 ohm twin lead. Typical feedpoint impedance is 119 ohms resistive and -692 ohms reactive. The EDZ is a fine antenna with several special properties.

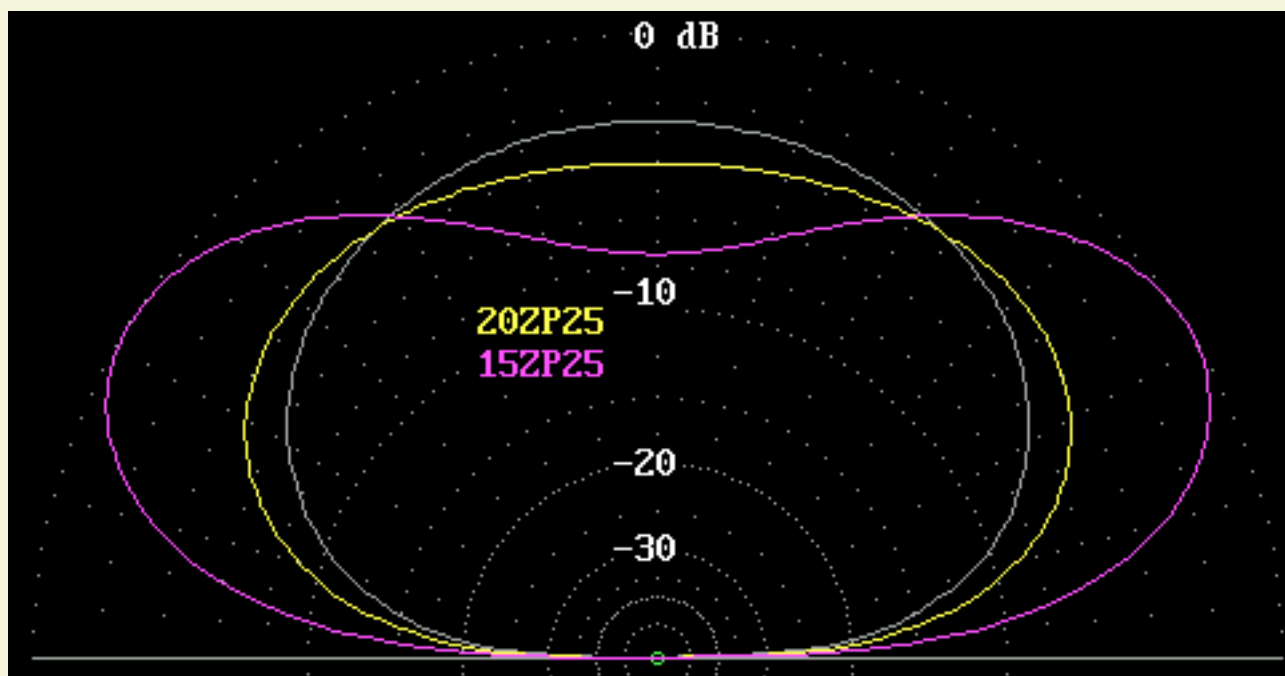

Above we see a comparison of the broadside views of of the 15 meter EDZ loaded at 40 meters (grey), 20 meters (yellow) and 15 meters (pink). The 10 meter plot is not included here because it is split on the end as this approaches a long wire on 10 meters. Gain on 15 meters in the favored direction is 11 dbi with a launch angle of 26 degrees.

The EDZ is just about as long as a wire can get in terms of wavelength before the donut broadside pattern typical of a dipole quits sharpening and splits into two lobes. In fact you can see that already the split lobes are appearing at 15 meters. As frequency is increased further, these lobes grow rapidly and the broadside lobe shrinks rapidly. As wavelength is further shortened on a given wire length, it starts acting like a long wire with these split lobes getting closer and closer to the direction of the wire and multiple minor lobes appearing.

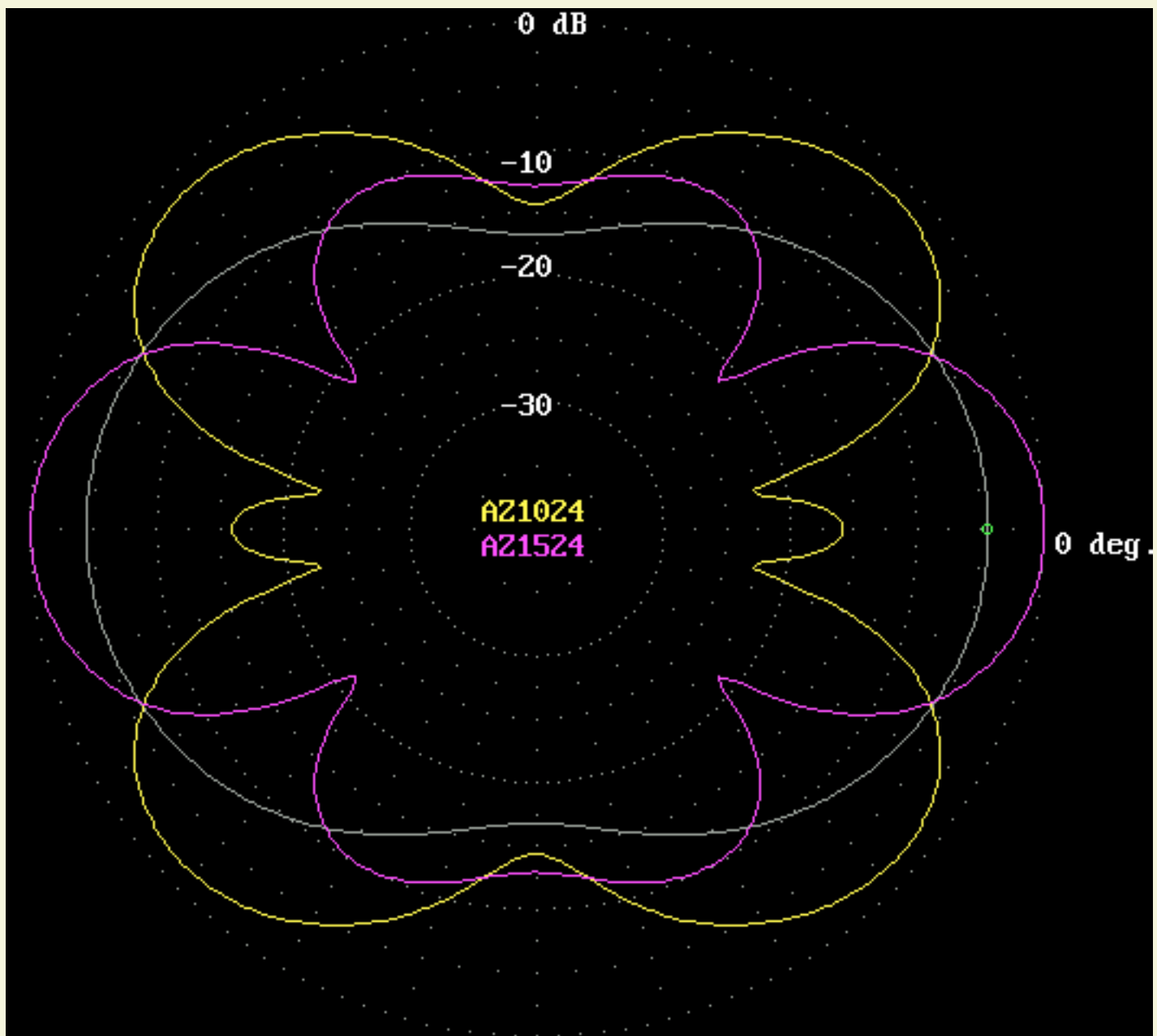

Viewed from above we see the 20 meter pattern (grey), the 15 meter pattern (pink) and the 10 meter pattern (yellow). Note how the 10 meter pattern has split and now has maximums that are 42 degrees off axis of the antenna broadside and an unfortunate null directly broadside to the antenna. This changes abruptly the favored angle of radiation of the antenna from dipole to long wire pattern. However, gain on 10 meters is excellent, being close to 12 dbi in the favored directions.

Another major consideration of the EDZ is mounting height. Since the dipole pattern is sharpened, it sends considerable energy towards the ground near the feedpoint. Thus the antenna changes pattern abruptly with height above RF ground. Optimum mounting height for such an antenna is close to .6 wavelength above RF ground. Below that there is some gain loss. Above that a vertical lobe starts to appear that saps energy from the desired low angle radiation.

This means an EDZ for 15 or 10 meters is a practical portable antenna. It can be loaded on the lower

bands, can be mounted only a 1/2 wave high which is just 21 feet at 15 meters and 16 feet at 10 meters, and it will perform adequately at lower bands while giving very worthwhile gain on the band it is specifically cut as an EDZ.

Of course the EDZ can be cut for lower frequency bands, but at 40 meters it now wants to be mounted about 70 feet high for best results. At 80 meters that climbs to 130 feet for optimum mounting height. Due to the fact the pattern will split just above the design frequency, the EDZ should be optimized for one of the higher bands you plan on using it on.

As long as you have a decent tuner designed to handle the reactive feedpoint which is highly capacitive and about 120 ohms resistive at the design frequency, you can effectively load an EDZ on many adjacent bands. The 15 meter one models as loading with a reasonable pattern on 40,20,17,15,12,10,6 meters. With the best results being broadside on 17,15 and 12 meters, though it works well on 20 meters.

[Return to UH Ham Club Home Page](#)

12/99

HAM RADIO HOMEMADE PROJECTS (homebrew HB9ABX)

update 24.July 2004

Auf DEUTSCH

- > [BESTE KW MOBIL-ANTENNE](#)
- > [MAGNET-LOOP ANTENNE, Berechnung, Konstruktion, Aufbauhinweise](#)
- > [Duplexer \(Diplexer\) 2m / 70cm](#)
- > [Duplexer \(Diplexer\) KW + 6m / 2m + 70cm](#)
- > [Koax-Kabeldaten \(Dämpfung, Kapazität, Abmessungen etc\)](#)
- > [Konversions-Tabelle zu Drähten \(AWG / SWG / BWG / W&M / metrisch\)](#)
- > [Entstörung von Spannungsinverter 12 V auf 220 V](#)
- > [Digimodes: Sauberes PACTOR - Adapterbox](#)
- > [Strom-Balun, Mantelwellensperre](#)

In ENGLISH

- > [WORLDS BEST HF MOBILE ANTENNA](#)
- > [MAGNETIC LOOP ANTENNA, design, construction, hints](#)
- > [Duplexer \(Diplexer\) 2m / 70cm](#)
- > [Duplexer \(Diplexer\) HF + 6m / 2m + 70 cm](#)
- > [Coax Cable Data \(attenuation, capacity, dimensions etc.\)](#)
- > [Wire Gauge Conversion Table \(AWG / SWG / BWG / metric\)](#)
- > [Clean PACTOR and digital modes - Adapterbox](#)
- > [Current Balun](#)

[Zurück / Back HOME](#)

The DX Notebook

Antenna Page



Antenna Links

- [Antennas from QRZ Shareware](#)
- [ARRL Antenna Projects](#)
- [AA3PX Antenna Page](#)
- [Antenna Analyzers--G3YCC](#)
- [Antenna Height?--AA3RL](#)
- [Antenna Links--WA6BOB](#)
- [Antenna Magic--KQ6RH](#)
- [Antenna Theory 101](#)
- [Antenna Projects--AC6V](#)
- [VE3GK Web Site \(Great Antenna Pics!\)](#)
- [How to Become an Antenna Guru](#)
- [AntennaX Magazine](#)
- [Ralph Holland, VK1BRH](#)
- [FVR Spitfire Array for Top Band](#)
- [Four Square Vertical Phased Array -- YCCC](#)
- [FUNET Antenna Archives](#)
- [Rhombic Antenna Home Page](#)
- [K1TTT Technical Reference](#)
- [The Antenna Elmer](#)
- [SM0VPO/G4VVJ Homebrew Antennas](#)
- [Roofspace Antenna's from G3PTO](#)
- [Coaxial Cable Specifications from NA5N](#)
- [Antenna System Evaluator](#)
- [Cubical Quad Antenna Calculator](#)
- [Shortened Dipole de GM4JMU](#)
- [160 metre "L" Antenna de N8SO](#)
- [How To Make Open Wire Feeders](#)
- [The Delta Loop](#)
- [How High Should my Dipole BE?](#)
- [AA3RL Transmission Line Calculator](#)
- [GAP Titan DX Evaluation](#)
- [EI7BA Multi-Band Quad](#)
- [The Crossed-Field-Antenna](#)
- [Antenna Visualization](#)

Tower Service

- [Rick's Tower Service](#)

Manufacturers

- [Aluma Tower Company](#)
- [Alpha Delta Antennas](#)
- [Antennas West](#)
- [Antennas & More](#)
- [Ant Panel Products](#)
- [Array Solutions](#)
- [Barker & Williamson](#)
- [Belden Wire & Cable](#)
- [Butternut & Bencher Antennas](#)
- [Bytemark \(Amidon Products\)](#)
- [Cable Experts](#)
- [CAL-AV Labs., Inc](#)
- [Comet Antennas](#)
- [Comtek Systems](#)
- [CushCraft Antennas](#)

Antenna/Tower Mailing Lists, Forums & E-Zines

- [TowerTalk Forum](#)
- [TowerTalk Reflector](#)
- [TowerTalk Reflector Archives](#)
- [The Condo Communicator](#) -- a newsletter directed toward helping hams solve the perennial problem of getting on the air from inside apartments, townhouses and anywhere that the traditional big-tower setup is forbidden or impractical. Dormitory residents and anyone not living on 40 acres in the country will find the suggestions in these articles helpful.



Antenna Pictures



"Antenna farm" of 13-year old Mike DeChristopher, KB1FWN. The topmost antenna on the tower is a 15-element Cushcraft at 80 feet. The next antenna down is on an out-rigger to the left, which is also a 15-element Cushcraft, and even further down are two phased 2GHz antennas, one on the left, and one on the right side of the outrigger. The beam on the bottom is a Bencher Skyhawk (When this photo was

- [Cubex Cubical Quads](#)
- [Custom Metalworks / Rotating Tower Systems](#)
- [Davis RF Co](#)
- [Delta X-Ray Antennas](#)
- [Diamond Antennas](#)
- [DX Engineering Antennas and antenna parts.](#)
- [DX System Radio](#)
- [EM Scientific: "New" MININEC](#)
- [EUR-AM](#)
- [EZNEC/ELNEC Antenna Modeling Software](#)
- [Force 12 Antennas](#)
- [GAP Antennas](#)
- [GB Antennas](#)
- [Giovannini Antenna Systems](#)
- [Harbach Electronics](#)
- [Heights Tower Systems](#)
- [High Sierra Antennas](#)
- [Hygain](#)
- [IIX Equipment Ltd.](#)
- [International Technology Antenna](#)

taken the reflector element was missing). The antenna closest to the photo is a Mosley TA33Jr at 36 feet.

Send your pictures!

- [**K3IWK's Chassis & Antenna Parts**](#)
- [**K0XG Rotating Towers**](#)
- [**KC2TX Antennas**](#)
- [**KN4LF Antenna Mfg and Sales**](#)
- [**KMA Antennas**](#)
- [**Larsen Electronics**](#)
- [**M2 Antennas**](#)
- [**LDG Electronics**](#)
- [**M2 Antennas**](#)
- [**Max Gain Systems**](#)
- [**MFJ catalog**](#)
- [**Mosley Antennas**](#)
- [**NEC-Win Antenna Modeling Software**](#)
- [**Nemal Electronics International**](#)
- [**PolyPhaser Corp.**](#)
- [**Radio Works**](#)
- [**Raibeam Antennas International**](#)
- [**Rohn Towers**](#)
- [**The R.F. Connection**](#)
- [**SGC World**](#)
- [**Steppir Antennas**](#)
- [**Titanex High-Tech HF**](#)

- [**Antennas**](#)
- [**Tennadyne**](#)
- [**Antennas**](#)
- [**Top Ten**](#)
- [**Devices, Inc**](#)
- [**Shoestring**](#)
- [**Antennas**](#)
- [**Sommer**](#)
- [**Antennas**](#)
- [**Texas Towers**](#)
- [**The Wireman**](#)
- [**TET-Emtron**](#)
- [**Antennas**](#)
- [**Trylon Towers**](#)
- [**US Tower**](#)
- [**Vectronics**](#)
- [**YagiStress**](#)

Please send comments, questions, suggestions or corrections to [W5KNE](#)

This document was last revised March 28, 2004

All brand names, Logos and Trademarks are property of their respective owners.

www.dxer.org

DXpedition Antennas for Salt Water Locations

A study on 20m Antennas

By Kenny Silverman, K2KW

Which is better a 20m antenna for an island DXpedition: Yagi at 25', or a vertical or two on the beach? (Hint, You are on a web site dedicated to vertical antennas - this is a trick question!)

"Conventional Wisdom" would say that Yagi (typically a tribander or 2 element full-size Yagi) would be a great choice of antennas for a DXpedition on a beach. What makes the Yagi so great? Lets examine the reasons to use a Yagi...

The Top 10 Reasons to use a Yagi on a DXpedition, even when you are on the beach:

1. You have used Yagis at your home station
2. You understand how they work
3. Yagis have directivity
4. Everyone else uses Yagis on DXpeditions, so the *must* be great
5. and...

Hmm. I can't think of any other reasons! But everyone knows that *any* antenna by the ocean works great, or at least "conventional wisdom" tells you so.

O.K., lets examine the use of a Yagi for a serious DXpedition to a remote island. For this discussion, let's assume you are going on a DXpedition of a lifetime to Kingman Reef (KH5K) in the middle of the Pacific Ocean. Kingman is an interesting island which is about 25' wide, and 450' long. The entire island is made up of broken shells, rocks, and rubble. There is no sand, trees, or anything else. The wind typically blows at a steady 30 mph. You are days away from any kind of medical help.

Now imagine the difficulty of assembling a typical triband Yagi, where if you drop a nut, you won't likely find it again. Then your team has to armstrong the 35-40 pound Yagi, which is on top of a 25' mast, into the upright position. I'm assuming you aren't even going to consider a rotator, which would add another 25 lbs. to the top of the mast! Remember that the wind is blowing at least 30mph, and you are standing on loose rubble. To get the Yagi installed, you will probably need 3-4 people to walk the antenna up and hold it in position while securing the base in the shells, finding stable guy points (for 2 sets of guys, or 6 ropes total) in the rubble, and adding a tag line for rotating the Yagi. Any slip-up, and one could easily get cut on the rubble, or even possibly break a bone if you fell. Any relatively small problem like that in the tropics will likely become seriously infected in short order. Based on the wind and the hazardous conditions, you will probably need 4-6 people for a few hours to safely erect the antenna. This is looking like a lot of effort for just one antenna...Ahh, but waiting hams are worth the effort aren't they?

Maybe, but your health comes first. You may wonder - is there an easier and better way?

First, lets think a little more about propagation to Kingman Reef. Kingman is in the middle of no place, more precisely, in the middle of the Pacific Ocean. Based on the distances from the 3 main target areas, most take off angles are likely to be very low, usually under 10 degrees, and often below 2 degrees! Europe is the main target, and you will likely spend half your operating time on long path (typically very low take off angles). Most typical Yagi antennas have a beamwidth of around 60 degrees, which means that you will likely have to turn the Yagi for each of the main target areas:

[Directions to target areas from KH5K:](#)

JA: ~ 305 degrees

Europe: from ~355 degrees to 20 degrees (which is the main emphasis for the expedition)

USA: from ~43 degrees to 58 degrees

Continuing with our original "Yagis are the best" scenario, you remain convinced that the Yagi is still the best antenna. What if I told you that a simple 1/4 wave vertical on the ocean, or better yet a 2 element vertical dipole array, would be a far better performer! I can hear the pundits saying: "Verticals are for kids!" or "Real men use Yagis!" You believe there is no way that a Yagi could be inferior to a vertical!

So why do you think that verticals work so poorly? Because "conventional wisdom" says so? Unfortunately "Conventional Wisdom" on the performance of vertical antennas usually comes from comparing a Yagi at home to the trapped vertical in the back yard. At home the Yagi *will* be better, but not on the ocean! On the ocean, you will see that verticals are the clear choice for high-performance antennas, that just happen to be easier to install too!

First off, let me dispel one long-standing myth: Horizontal antennas over salt water do *not* get any enhancement from the salt water (from increased ground conductivity). Well, to be exact, almost all useful angles for HF propagation get little or no useful enhancement. The horizontal antenna (and so does the

vertical) receives a benefit from the ocean, because the ocean presents an undisturbed foreground for the incoming and out-going energy. Salt water also has less loss than typical ground for every reflection. To show you the impact of ground conductivity, the following two Figures were created: Figure 1 (below) shows that the take off angles in the 30-90 degree range (straight up) do get some limited enhancement from the salt water. Figure 2 (below) compares a 2-element vertical array over land and salt water. The only antenna that gets *significant* signal enhancement by being next to, or over, salt water is a vertical. In fact, verticals get about a 6 dB increase of gain when placed over salt water, and the radiation in the pseudo-Brewster angle is filled out (which is radiation under ~12 degrees). So the salt water is enhancing signals right where most DX signals are arriving - in the pseudo-Brewster angle!!

Figure 1: 2-element Yagi at 25' over land and salt water. Peak gain is 10.40 dBi (over salt water) at 38 degrees take off angle in this design.

Figure 2: 2-element vertical dipole array (parasitic) over average land and salt water. Peak gain is 10.01 dBi (over salt water) at 8 degrees take off angle in this design.

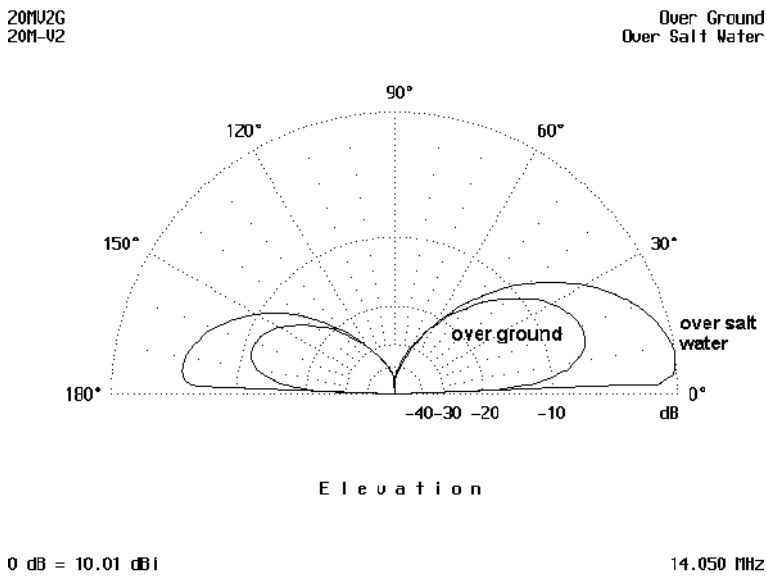
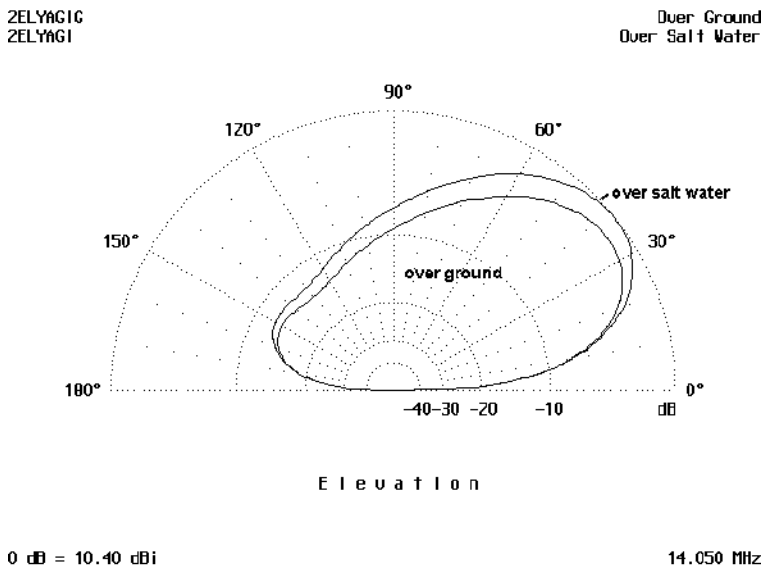

OK. Let's get back to Kingman.

I suggested that a simple vertical would be better for most useful take off angles... let me show you why. Figure 3 (below) compares a 2 ele Yagi at 25' height over salt water compared to a 1/4 wave vertical over salt water. The antenna with lots of gain at 40-degree take off angle is the 2-element Yagi at 25'. The other antenna is the 1/4 wave vertical. Notice, at take off angles below 10 degrees, the vertical is the hands down winner! You may point out that the Yagi has more "gain". This is true, but the extra dB or two gain is at take off angles that don't matter! A simple vertical by the ocean can and will usually outperform a Yagi on most typical DXpedition paths, because the energy from the vertical has fewer hops to the target! It's all a matter of the angles of the arriving signals.

Figure 3: Yagi at 25' compared to a 1/4 wave vertical over salt water

2ELEYAGI
20MU1

Over Salt Water

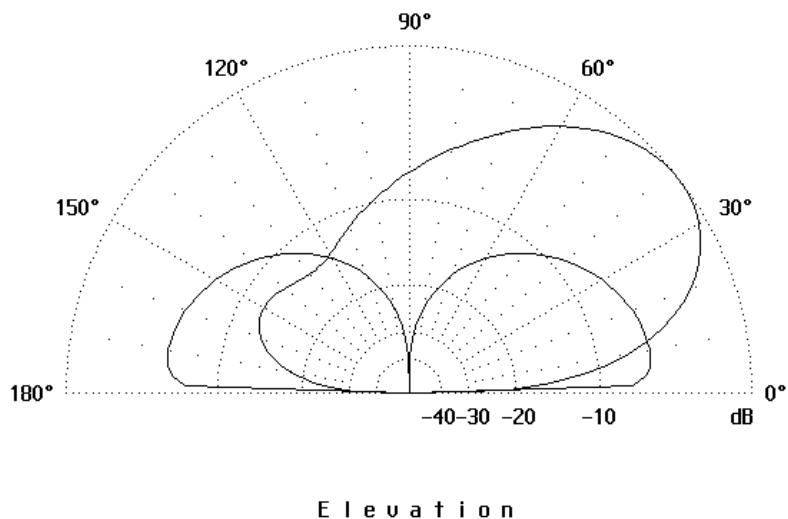

0 dB = 10.53 dBi

14.050 MHz

As you saw in Figure 3, the 1/4 wave vertical is a good performer. Even better for our Kingman Reef expedition is that a single vertical is really light weight (maybe 3-4 lbs for the 16' vertical), and can be assembled and installed in just a few minutes. Compared to the Yagi, the vertical only needs some rudimentary guying, and you don't have to worry about turning the antenna! And since you are going there to operate, you can be on the air in 30 minutes if you wanted! Try that with the Yagi.

I bet that some of you aren't convinced yet that a single 1/4 wave vertical is a good enough choice. OK, lets up the "vertical anti" a bit, and rather than a 1/4 wave vertical, lets examine a 2-element parasitic vertical array using 1/2 wavelength vertical dipoles. To better understand what this array looks like, picture a 2 element Yagi standing vertically, but minus the mast and boom to support it (much less overall weight). (see picture to right)

There are a few advantages of using vertical dipoles (vs. 1/4 wavelength elements): they eliminate the need for radials, and by raising the feedpoint, you achieve an additional 1.5-2.0 dB of gain at low take off angles. A parasitic vertical array (vs. a phased array) is an easy way to increase gain and directivity, yet is still very easy to install and tune up. The parasitic array needs less parts than phased array, which is an important aspect on DXpeditions. Figure 4 (below) compares the 2-element Yagi at 25' to the 2-element vertical array using vertical dipoles. You can see that the vertical array now has nearly the same peak gain as the Yagi, but the gain is focused right where most of the arriving signals are coming from: 0-10 degrees! And the verticals are now the clear winners from 0-20 degree take off angles - who could ask for more? Since many of the signals are arriving at around 1 degree take off angle, often the verticals can be 20 dB stronger than that Yagi! Talk about a band-opening antenna!



Figure 4: Yagi @ 25' compared to a 2-element vertical array using vertical dipoles

2ELEYAGI
20M-U2

Over Salt Water

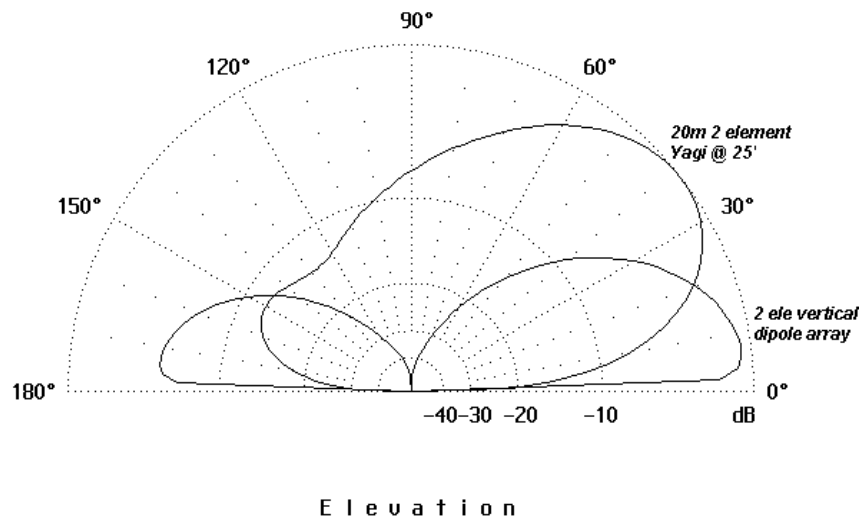

0 dB = 10.53 dBi

14.050 MHz

But I'm sure that the Yagi-lovers are saying: "I bet if you were able to get the Yagi up to a good height like 50', that it would surely beat the vertical array. Think again dude! First off, installing a Yagi at 50' on a DXpedition is difficult, if not impossible. Secondly, it still doesn't compare to the vertical array! Figure 5 (below) compares the 2-element 20m Yagi at 50' to the vertical array. Notice that the Yagi now has a large amount of energy being radiated straight up. Sure the main lobe is lowered, but the 2-element vertical will still be better on most DX signals.

Remember, that a typical tribander weighs at least 35-40 lbs., and add another 20 pounds or so for the mast, for a total of at least 55-60 lbs. A two element full-size vertical dipole array for 20m weighs no more than 18 lbs. if properly built. A vertical array is much more efficient if you consider a key metric for DXpeditions: dB per Pound of Antenna.

Figure 5: Yagi @ 50' compared to 2-element vertical array using vertical dipoles

2ELEYAGI
20M-U2

Over Salt Water

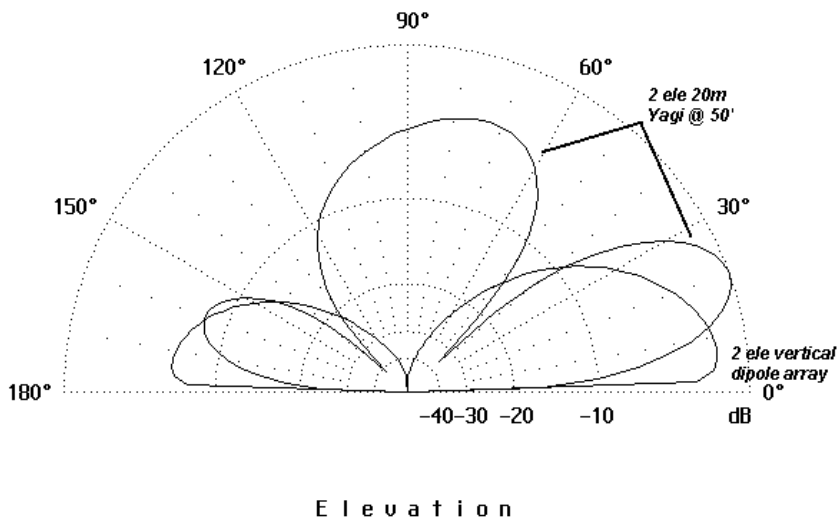

0 dB = 11.61 dBi

14.050 MHz

And you still need more convincing? OK, Figure 6 (below) is the energy at 5-degree take off angle. The antenna with all the signal (the big one) is the 2-element vertical array which has 9.9 dBi at 5 degree take off angles. The antenna that is down 12-20 dB in all directions is the good ole Yagi at 25'... Another key point is that a 2 element vertical array has a very wide pattern, which is on the order of 120 degrees for the -3dB points. Thus the 2-element vertical array can cover all 3 main target areas without turning the antenna! In addition, if there are callers from other directions (assumes there is a water path in those directions), the vertical has more useful gain than the Yagi does on azimuths that are off the side or back of the antenna.

Figure 6: Energy at 5 degree take off angle of a Yagi @ 25' compared to a 2-element vertical array using vertical dipoles

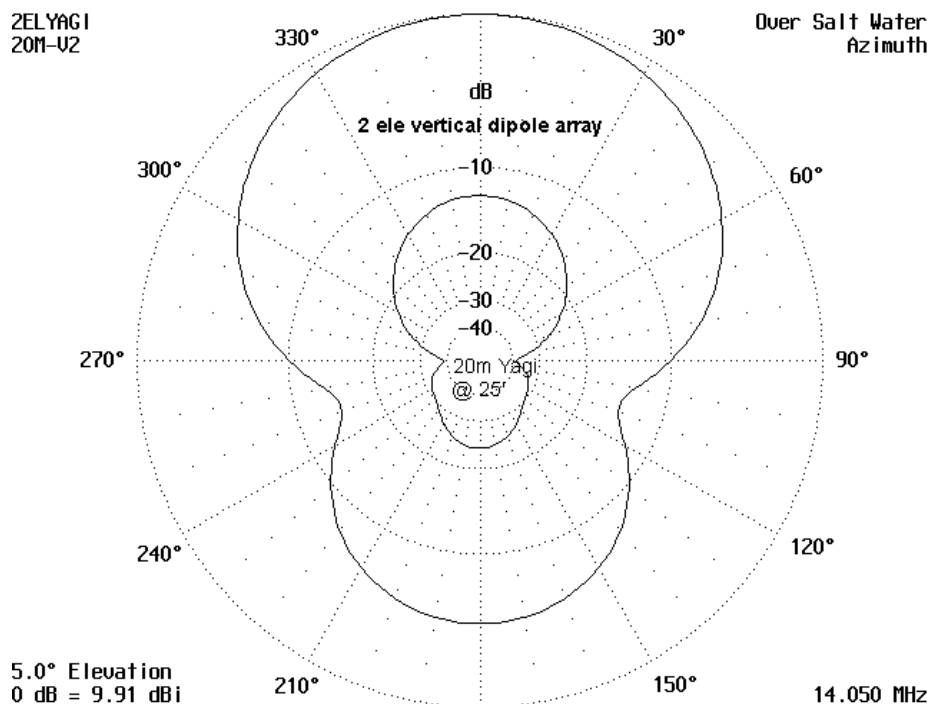

Some of the pundits might still say this was a "Made up" example...Sorry to disappoint you, but the Kingman Reef example was real, and was based on the planning discussions for the upcoming Kingman Reef DXpedition. For many island DXpeditions, vertical arrays should be given more consideration on the high bands than they currently are receiving.

The computer models have been verified by empirical testing we did from salt flats while shooting over salt water. The measured data follows the model. Verticals were selected for the "Team Vertical" locations in the Caribbean and comparisons to full-size Yagis were made, confirming the models, as well. The comparisons were done over many continuous hours of switching back and forth, with differences of up to 9 S-units (on an 'MP meter), averaging 2-4 S-units, in favor of the verticals. The Team Vertical Yagis were occasionally used during the contests, but only to cover directions where the verticals has nulls. This might be one of those situations where if you haven't tried it, you don't realize what is happening. How good is a larger vertical array using vertical dipoles? Tom, N6BT, has commented that they are truly on par with the large commercial curtain arrays he used in Saipan. Salt water is the key to verticals. If you can get close to salt water, or literally sit right in it, such as at Kingman Reef, verticals are the answer to high performance antennas - besides being significantly easier to transport and set-up.

73, Kenny K2KW

Special thanks to Tom Schiller, N6BT, for offering input to this article.



[Start a Group](#) - [My Groups](#)

eh-antenna · EH Antennas

[\[Join This Group! \]](#)

[Home](#)

Members Only

- Messages
- Chat
- Files
- Photos
- Links
- Database
- Polls
- Members
- Calendar
- Promote

([Already receiving group email?](#))

Description

Category: [Amateur and Ham Radio](#)



This group has been created to promote discussion relating to the EH Antenna. There should be many with experience with the EH Antenna, so don't be shy about asking questions on construction and efficiency.

There is a file and picture section, feel free to use them.

If you wish to Un-subscribe, use yahoo groups to un-subscribe just like you subscribe, the instructions are there, use them.

DO NOT SEND A MESSAGE TO THE GROUP ASKING SOMEONE TO DO IT FOR YOU

Picture of Ted (on the left) with me selling the Backpacker Kit at the Dalton, Georgia Hamfest.

Group Info

Members: **659**
 Founded: **Nov 11, 2002**
 Language: **English**

Group Settings

- Listed in directory
- Open membership
- Unmoderated
- All members may post
- Archives for members only
- Email attachments are permitted

What's New

New within the last seven days:

Members: **3**

Messages: **18**

Message History

| | Jan | Feb | Mar | Apr | May | Jun | Jul | Aug | Sep | Oct | Nov | Dec |
|------|-----|-----|-----|-----|-----|-----|-----|-----|-----|-----|-----|-----|
| 2004 | 272 | 66 | 171 | 89 | 108 | 125 | 38 | 45 | 18 | | | |
| 2003 | 142 | 267 | 493 | 518 | 433 | 411 | 249 | 141 | 130 | 145 | 105 | 429 |
| 2002 | | | | | | | | | | | 188 | 134 |

Group Email Addresses

For more information: <http://eh-antenna.com>

Post message: eh-antenna@yahoogroups.com

Subscribe: eh-antenna-subscribe@yahoogroups.com

Unsubscribe: eh-antenna-unsubscribe@yahoogroups.com

List owner: eh-antenna-owner@yahoogroups.com

Yahoo! Sponsored Links

[Ham Radios at Shopping.com](#): Find, compare and buy products in categories ranging from misc. Electronics to tools and hardware. Read product reviews and compare prices from thousands of online stores.

www.shopping.com

[Ham Radio Operator - Badge](#): Ham radio operator badge. Custom engraved with your personal information. Name, Call, Class. Law enforcement quality badge.

www.maxsell.com

[Ham Radio - mySimon](#): Ham radio on mySimon. This great comparison shopping site offers you excellent product and pricing information across the Web plus a directory of links.

www.mysimon.com

Copyright © 2004 Yahoo! Inc. All rights reserved.

[Privacy Policy](#) - [Copyright Policy](#) - [Terms of Service](#) - [Guidelines](#) - [Help](#)

E-H Antenna

[[Home](#)] [[Up](#)]

Background

Many antennas function because of common mode currents, rather than working in spite of them. Two popular examples are CFA and EH antennas. Another recent example, appearing in Antennex's compact antenna articles, is a thick stub "vertical" with no counterpoise.

All of these antennas become significantly poorer radiators if [common-mode currents](#) on feedlines are eliminated. Why? Because the feedline is the actual radiator, *NOT the tiny thing they call the antenna.*

Misunderstanding or misapplying Maxwell's equations and the principles behind radiation, in combination with missing some very key points of conventional circuit theory, causes problems. Some of us have unwittingly attributed increased feedpoint resistance and/or seemingly disproportionate amounts of radiation from very small structures to new methods of radiating EM waves. Reviewing these antennas and the theoretical or technical mistakes surrounding them will help us understand how antennas and transmission lines work. With that knowledge, we can build better antenna systems. The fastest and best way to learn is often to look in detail at mistakes!

What They Claim

Articles and user reports of CFA, EH, and thick stub verticals (without groundplanes) appearing in Antennex and other internet publications have one common thread, the operational descriptions almost always include strong indicators of problems with feedline common-mode current.

Authors commonly warn users to NEVER choke feedlines with baluns and to "be sure the feedline is straight and in the clear"! Authors lay blame for RF burns from feedlines or shack equipment on the antenna's "high radiation efficiency", claiming these small magical antennas radiate so efficiently they naturally excite the feedline and equipment more than full-size antennas.

For example, Ted Hart (of EH Antenna fame) claims the following at:

http://eh-antenna.com/documents/RF_on_the_Coax.pdf

"RF on the Coax

Due to the large radiation at the EH Antenna, there will be some RF coupling to the coax. Whether this is a problem is dependent on the radio you use. Some are subject to RF coupling into the audio system, which causes severe distortion while transmitting. On some field day setups with 100 watt transmitters we have had so much RF on the radio you can get an RF burn. Below we have suggested ways to eliminate the RF coupling problem."

In the above statement, Ted actually acknowledges current on the feedline shield and RF-voltage-on-chassis problems. The problem must be severe when a low-power 100-watt radio causes a burn. Like any good salesman, he turns a design shortfall into a feature! According to the author, unwanted RF on the feedline doesn't come from a feedpoint or antenna design problem like it does on other antennas, in this case it appears because the antenna works so well!

Here's what actually causes RF to appear on a coax shield and radio chassis. RF can only appear on the radio chassis through two methods:

- 1.) The antenna, from poor feedline or feedpoint design, can couple to the radio chassis through external wiring or cables attached to the radio.**
- 2.) The radio chassis itself, being large in terms of the wavelength, can actually become an antenna and receive energy from actual desired "over the air" signals.**

(Many of us have these problems. Click on [this link](#) to see one reason why.)

In this case, we can probably rule out reason two above. It is unlikely the chassis is a large portion of a wavelength long on 20-meters and that the antenna field is suddenly so strong it is "lighting up the house" with RF. After all, if power is radiating effectively it will all be going out to distant stations and NOT cooking you or the radio gear in your house! That only leaves reason one, poor feedpoint and antenna design, as the cause of common-mode feedline or wiring currents that excite the coax shield and eventually the radio chassis, as described in method one.

Actually someone has measured this, and posted it to a web page!

http://www.home.earthlink.net/~calvinf15/_technical/

When the time-varying current from the transmitter flows in any conductor, we will have charges accelerating in the cable. The outside of a shield is no exception. A feedline's shield will radiate proportionally by the ampere-feet of the cable. just as any other conductor will. Of course the antenna element will radiate also, but there is something else to consider.

A very small current flowing unopposed over a large linear distance will radiate quite a strong signal, because radiation resistance of a long antenna is generally very high compared to very short antennas. You can find this explained in the [Radiation&Fields](#) and [Radiation Resistance](#) articles on this site, and in engineering textbooks such as those written by Jasik, Kraus, and Jordan-Balmain. From all of this, we know the shield radiates.

The inventor of the E-H antenna goes on to say:

"If you use RF beads, since the coax shield is not a magnetic shield, the beads affect both the inner and outer conductors. Therefore, most of the transmitter power will be converted to heat. Not good."

Not a very knowledgeable statement at all, at least from the standpoint of how shields work!

Time-varying fields can not pass through a shield that is more than several skin depths thick. The inner part of the shield and outer part are isolated by the skin effect, and nothing passes through. The ARRL Handbook, Maxwell's book "Reflections", Reference Data for Radio Engineers, and dozens of other amateur radio and engineering texts describe this effect correctly. If we bring a time-varying electric field to zero in a system, the time-varying magnetic field is also by definition zero. The shield DOES isolate the center of the cable from time-varying magnetic fields on the outside of the cable!

If that is true, why then does a shielded cable passed through a current transformer used in a directional coupler appear to pass RF magnetic fields? Why does the RF magnetic field seem to "pass through" the shield of a shielded receiving loop antenna? The answer is quite simple. There is a gap or intentional break in the shield.

Current on the inside of the shield "spills over" the edge of the shield where the shield is broken, and causes a current on the outside of the shield. There is also a voltage across the gap at each end of the shield. We have both our time-varying voltage and current, via a circuitous path to the shield ends! Our Amateur texts explain that effect, as do all of the engineering texts dealing with shields on transmission lines. If the gap is closed and the shield's ends are shorted together, making voltage across the shield gap zero, the magnetic field no longer "seems to" penetrate the shield!

If a shield did not behave this way, we'd be in serious trouble in the radio world. Without the shield stopping both magnetic and electric time-varying fields, we could not shield our radios. We also could not shield our microwave ovens, with non-magnetic materials!

If anyone thinks a ferrite core affects the impedance inside a coaxial cable that does NOT have significant common mode current, they only need to slip some beads over a cable on a working normal "cold-for-RF" feedline. You will find absolutely no difference in system performance when

beads are added, proving Ted does not "have it right" in the text above that appeared on the E-H antenna web site.

The author and inventor of the E-H goes on to say:

"Use of a small choke made of several turns of the coax is good. We find that a wire connected to the ground side of the coax at the antenna and connected to either a ground rod or a wire laying on the ground will eliminate RF problems - in most cases. For some radios we also need to add a ground wire to the radio."

Of course adding a ground wire might help! The ground wire becomes the path for common-mode currents, or at least a portion of them. The additional wire to ground becomes part of a long-wire antenna (made by the cable shield) that actually does most of the radiating!

"A preferred method is to run the coax to ground then back to the radio. Near ground, connect the shield of the coax to a ground rod or radial. Another method is to connect a wire from the radio to ground. If the radio is very far from ground you will need to add a series resonant circuit in the ground wire to effectively cancel the inductive reactance."

It is understandable why this is a preferred method! The outside of the coax shield can remain the primary antenna, saving us the bother of installing the additional ground wire that becomes the antenna in the previous suggestion!

"It may take one or more of the above to solve your problem. Remember that if you have a good ground on the antenna, you have also minimized problems with lightning."

In the above text, we can see every solution carefully avoids installing an effective choke balun on the feedline. A properly designed and effective choke balun has no effect on a coaxial feeder or system SWR, unless the feedline is radiating!

Let's look at another E-H antenna experimenter and former proponent of the E-H antennas test of a 160-meter E-H antenna. You can read the text directly at:

http://www.qsl.net/iz7ath/web/02_brew/18_eh/english/pag11_eng.htm

Steve writes:

"With my short (and easy) tests I deduce the EH lose about 10 dB versus my short 10 mt vertical with capacitive hat in the top;
10 db is a big amount of power, but remember we are using 2 small cylinder of 37,5 cm on 160 mt band;
my vertical performed better than a 40 mt long sloper, so, may be, loss versus full size dipole is not too much."

Steve claims the E-H antenna loses about 10dB compared to a 1/4wl sloper, which has an unpredictable efficiency. A typical sloper 1/4wl sloper is likely only around 50% efficient in the best situations, and more likely much worse! The actual range can be from 10 to nearly 100% efficiency. Steve's data repudiates Ted's claim and the CFA inventors claim that "crossed-field" antennas provide high efficiency.

"There seems to be something good;
May be optimizing something we can have more gain (or, better, we can lose less dB);
This antenna can be useful on the low band, especially on 137 KHz (the EH cylinder should be 6 mt high with a 2mt diameter).
On the web I've seen an other similar antenna (ISOTRON), which seems coming (as EH Antenna) from CFA antennas;
On the Italian Radio Rivista (1995-1996) there were some informations about an "Antenna Toroidale" which in same way remember the EH: will be interesting build and test one."

Steve seems to be saying something we all agree with. A short antenna will radiate, but not nearly as well as a full-size antenna.

"By the way, I think that my EH is not for Dxing; it will be useful for that radioamateur who have no possibility to install "long" antennas for low band, but want just to have local QSO or few contest-contact."

I agree! 10-20dB loss from a full size antenna would not make a good DX antenna! Now here come the current-on-the-feedline problems:

"Other point: tuning;
I think it's not as simple as others say; I've used an MFJ259B which tells me all about the antenna, but the tuning was critical. On the other side construction is easy;
I want suggest to you , when tuning, to connect the MFJ259B to the shack ground (if there's one). If not, EH will probably resonate higher (20-30 KHz)."

If grounding and ungrounding an antenna analyzer or any other piece of equipment connected to a coaxial cable causes resonant frequency or SWR of an antenna to change, the system has severe feedline radiation problems. See my article on [testing baluns](#).

"Coaxial cable influence: inserting more coax cable, the resonance seems to vary a little; I suppose that's normal;

I don't know for certain if the line radiates or not; I've added two iron-powder coil forms back my TX and EH performance was unchanged. Then later I've added 2 big ferrite beads with a lot of turns on the roof (at the feed point of the EH) and all has changed. My signal was 3 S point weaker than before and S.W.R was very high.

I don't know if that loss is due to the changed resonance in EH (as I said before, outside the bandwidth performance goes down quickly)."

We see again that any attempt at reducing feedline radiation results in an antenna that does not radiate very well. With the feedline choked, Steve's EH antenna dropped 3 S-units in addition to the original 10dB from his sloper, or maybe 25dB or more!

There surely is a hidden message in all of the above contradictions!

How the E-H Antenna *Really* Works

There are many examples where designers intentionally use common-mode currents. Examples are found in textbooks, such as the "Antenna Engineering Handbook" by Jasik on and around page 22-6.

The antennas at the right, copied from Jasik's textbook, outline the derivation of a skirt collinear antenna from a simple feedline with the open end terminated into a conductor. (It could be a ground

22-6

VHF AND UHF COMMUNICATION ANTENNAS

Two or even three skirts may be added to the mast as shown in Fig. 22-5c, but reduced excitation of the lower sections diminishes the effectiveness of each additional skirt.⁶ Thus, while the multiple-skirt coaxial antenna resembles a collinear array of in-phase half-wave elements, its gain is not as great. Typical gain values are tabulated in Table 22-2, but since no test data are available for this type of antenna, values given are merely engineering estimates.

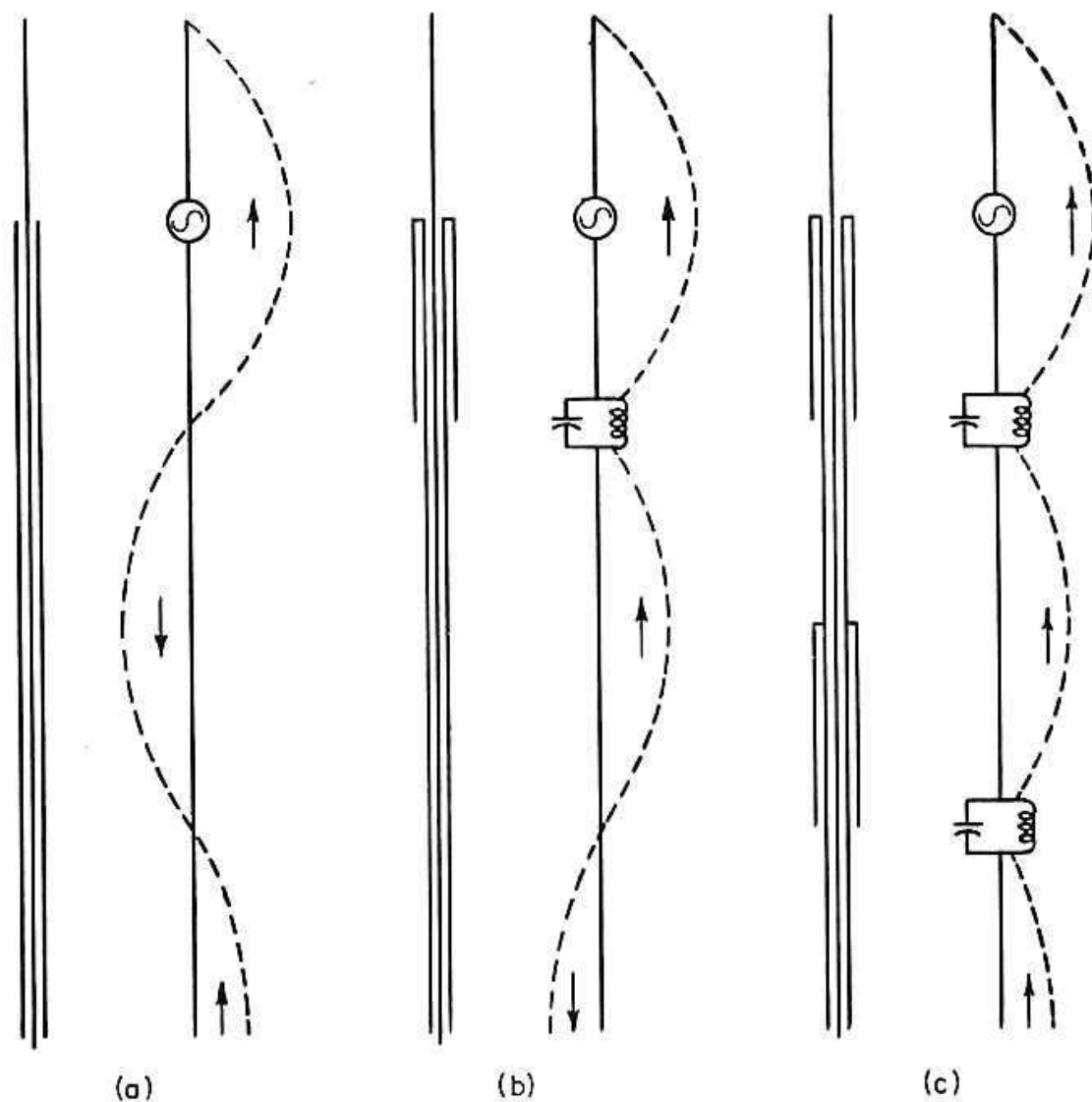

FIG. 22-5. Evolution of multiple-skirt coaxial antenna.

The relatively large diameter-to-length ratio of a practical skirt produces an effect which requires that the exterior length of the skirt be reduced by a factor of 0.8 to 0.9 and the interior length by from 0.95 to 0.98.⁶ This is accomplished by cutting the skirt to the proper exterior length and inserting a dielectric slug in the skirt to increase its electrical length.

rod or an antenna, like a Beverage or large loop, the antenna does not have to be an "open circuit".

Looking at (a), we find by hanging any conductor from the end of a coaxial cable the shield is excited (on the outside) with common-mode current. The electrical equivalent of the OUTSIDE of the shield is just as if a generator located at the end of the shield was driving the outside of the shield as longwire antenna. This goes along with Kirchoff's Laws, that tell us the sum of currents entering a point must equal the sum of currents leaving that point. For any current to flow up into the antenna, an equal current must flow back down over the outside of the shield.

With one ampere flowing up the center conductor into the "stinger" at the coax's end-point, the same level of current flows back over the outside of the shield. (The shield's inside and outside are isolated by the skin-depth of the current at the operating frequency, and can be treated as two independent conductors that are connected over the open edge of the shield.) We *MUST* have this current simply because this is how coaxial cables work, the current on the inside of the shield is *ALWAYS* equal and opposite to current in the center conductor. There has to be some place for that shield current to flow, so it makes the bend over the end of the cable and flows back down the outside.

This is also why, when we use a cable's shield as a ground lead the center conductor and inside of the shield do nothing to reduce resistance. Any current that flows down the center conductor is cancelled by current flowing on the inner wall of the shield, the result is no current at all flows down the center conductor as long as the shield is several skin depths thick.

Many antennas intentionally and unintentionally use this principle, two examples are shown in (b) and (c).

A recent Antennex Article on a "magical" ultra-compact antennas claims an identical system, using a loaded fat cylinder, has an extremely high radiation resistance and excellent performance because some magical field-trickery increases the radiation resistance of a thick cylinder at the antenna end. Certainly radiation resistance is somewhat high...but not for the reason something magical or special is happening!

The small coil-loaded cylinder is actually only a fraction of the antenna length, and being so short has a very small radiation resistance. The point missed is the shield of the cable is very long, and is in series with that short section. Since the shield is long, it also has a reasonably high impedance both from radiation resistance and loss resistances. Shortening the length of the end-stub results in an insignificant reduction in radiation resistance, because the overall length of the radiating system is very long! We have a simple off-center fed dipole, with one very long leg and one very short leg!

The main radiator is the outside of the feedline shield, not the tiny thing being called an antenna!

Unless we make the coaxial shield an infinite length or pass it through what amounts to an infinite groundplane with zero resistance, current continues on down the cable shield. Looking at (c), we find even multiple sleeves appearing as parallel tuned high-impedance circuits do not fully decouple the

shield. Many collinear antennas work on this principle, yet E-H antennas and others attribute it to some form of electro-vooodoo.

Jerry, K5OE: Home Brew Amateur Antennas

[Home](#)

LEO Sat. Antennas:

- [Eggbeater II](#)
- [Eggbeater](#)
- [TX Potato Masher II](#)
- [Texas Potato Masher](#)

Portable Antennas:

- [70 cm Handi-Tenna](#)
- [2m Mobile Vertical](#)

AO-10 Antennas:

- [70 cm Quagi](#)
- [AO-10 Beam](#)

AO-40 Antennas:

- [Patch Feeds](#)
- [Dual Patch Feed](#)
- [Helix Experiments](#)
- [MMDS Dishes](#)
- [S-Band Toys](#)
- [2' Dish Mods](#)
- [Drake 2880 Mods](#)

Miscellaneous:

- [Satellite Links](#)
- [Russia 2000](#)
- [Home Brew Hardware](#)
- [Picture Album](#)



The *Texas Potato Masher II* Antennas at 10 m elevation

Welcome to my Home Page (best viewed at 1024x768). I have a few "home brew" antennas here as well as some links below to other sites that may be of interest to the amateur builder/experimenter. I hope you find something of value here. Please send me any comments or suggestions to at (insert my callsign here)@amsat.org.

If you would like some information on amateur radio operation, please visit the [American Radio Relay League \(ARRL\)](#) for an introduction to this wonderful international fraternity. If you would like information on amateur satellite operation, please visit the [Radio Amateur Satellite Corporation of North America \(AMSAT-NA\)](#) for the latest in news and software. If you are new to amateur satellites, here is an [introduction to the "EasySats"](#) (slightly dated, but still useful). If you are wondering what kind of antenna(s) you might want or need, please read this [introduction to amateur satellite antennas](#) and this [LEO satellite antenna cost/benefit analysis](#).



I live in [Houston](#), Texas; about 90 km from the Gulf of Mexico (**New!** UPDATE: I am temporarily in Darwin, NT, Australia, operating as VK8OE ([APRS](#)). Weather here is hot and humid, just like Houston. My QTH in Houston was in a neighborhood with "deed restrictions," outlawing antennas of any kind. My response to this situation was to install "low visibility" antennae that are hidden from the street and do not extend above my roof line. Please see my various antennas for examples.

 [HF Antenna Pages of Interest:](#)

[W4RNL Antenna Design & Modelling](#)

[TowerTalk Reflector \(Contesting.com\)](#)

[AC6V Home Brew Antenna Page](#)

 [Satellite Antenna Pages of Interest:](#)

[Quadrifilar Helix Antenna](#)

[Lindenblad Omni Antenna](#)

[W1GHZ Microwave Antenna Book](#)

[KK5DO's AMSAT Net Antenna Script](#)



Please note: all written material, illustrations, and pictures are copyrighted (c) by the author, but may be copied or distributed without permission for any non-commercial use.

73,
Jerry, K5OE/VK8OE
EL29ds/PH57km



00037973

Last Updated: 1-Oct-2001



A WORLD LEADER IN COMMUNICATION PRODUCTS

900MHz ISP Antennas

ISP PRODUCTS

2.4GHz 802.11B Ant

WE HAVE YOU COVERED FOR ALL YOUR COMMUNICATION NEEDS



HOMELAND SECURITY



2.4GHz-2.5GHz 802.11B Ant

AMATEUR PRODUCTS

Contact Sales Dept

COMMERCIAL PRODUCTS

ONLINE ORDERING

M2 ANTENNA SYSTEMS, INC.
4402 N. SELLAND AVE. FRESNO, CA 93722
559.432.8873 FAX 559.432.3059

NEWAZ/EL-1000 TRACKING PEDESTAL

The Gallery of the EME Arrays.

A Collection of EME Reflector Antennas and YAGI Arrays.



28-ft Dish at K2UYH.

The Majority of these pictures were provided to K2UYH for the 432 MHz And Above EME Newsletter.

Many of these antennae have been **Designed, Constructed and Optimized** by Radio Amateurs.

The Antenna represents a Major Module in a **Moonbounce and/or Weaksignal System**. It is an essential part in the receive as well in the transmit link.

A **1 dB increase in antenna gain** delivers 1 dB increase in ERP and, depending on the frontend, it could deliver a more than 1 dB increase in system S/N ratio.

A **significant** improvement in an EME link Budget!

Antennae from the 432 MHz and Above Newsletter

- [K1RQG's dish under construction.](#)
- [DF3RU at 432 and 1296 MHz.](#)
- [W2DRZ and K2TXB 3 cm, a new dish is under construction. EME](#)

- [K3HZO at 432](#)
- [Details of polarization and rotation at K3HZO](#)
- [OE9FKI at 5730. MHz](#)
- [OZ9AAR 5 meter dish with W2IMU feed.](#)
- [W4NJP 36 ft dish.](#)
- [W5UN, the Mighty Big Array.](#)
- [K5GW's 432 array.](#)
- [EA3EM, 3MD, 3UM, 3AQJ, 3AYX, 3BTZ, 3DXU, 3EHQ, 9AI and I5WBE.](#)
- [F6KSX and F1EHN and their 23 and 3 cm EME Antenna.](#)
- [F5PAU Dish.](#)
- [Dishes for 432, 1296 and 10 GHZ at F6CGJ. Worked WA7CJO and SM4DHN on 3 cm.](#)
- [10 GHz at JA0IXX](#)
- [2 x 16 x 22 elem K1FO's for JH0YSI. 16 Hor.+ 16 Vert.](#)
- [JH3ERQ, JH3EAO, JR4BRS and JA4BLC](#)
- [DJ9YW, Heinrich 4.5 meter, f/D=0.47, W2IMU Circular Feed. 360 W HPA.](#)
- [6 Yagi's at JH4JLV.](#)
- [N2IQU's 48 ft, f/D=.41, inner 36 ft. covered with fine mesh.](#)
- [Sunrise in the Low Lands, PA0JMV.](#)
- [My good friend, PA0AVS and his upgraded Low Noise Parabolic Horn for 432 and 1296 MHz.](#)
- [3.7 meter at HB9HBU.](#)
- [G3WDG de VK3ALU, 3.7 meter. Box behind dish with TWTA, Relays and Xverter.](#)
- [G3LTF, 20 ft Dish with 70 cm Feed installed.](#)
- [JS3SIM with 4 25 element K1FO Yagis.](#)
- [JR9NWC 8 Yagi Array high up in the blue Sky.](#)
- [KB2AH and his antenna park.](#)
- [Chuck, W8MQW with 8 K1FO yagis at 432 MHz and a 10 ft dish on 1296 MHz from the country side.](#)
- [W8MQV with 20 Watts on 10 GHz](#)
- [The Black Forrest uW Moon Bouncers, DJ7FJ\(r\), DL2GSG and their 4.5 m ANDREW Dish. Rig under dish.](#)
- [OK1DFC with 4 * M2 Yagi's.](#)
- [JA2TY, 4 * 33 element K1FO and FHX06 LNA.](#)
- [Takuhei, JA2TY running 2 * 3CX800A7.](#)
- [5M Dish for 23 cm at DF9QX.](#)
- [PA2CHR Array with 4 * 35 el Yagi's.](#)
- [JA5OVU's new 16 * 14 el Rear Mounted Yagi Array.](#)
- [VE6TA, with 4 * 22 element K1FO and a 3.7 m, expanded to 5 m, on 1296 , .3 F/D.](#)

- [IK0EQJ, active on UHF and EME with bay of 4 Yagi's.](#)
- [The N7ART 1296 feed article and the modification of this feed by VE1ALQ](#)
- [VE1ALQ's modified N7ART dual band Feed](#)
- [The feed,...the feed at VE1ALQ](#)
- [Is this the Focal Point or Not? Darrell, VE1ALQ](#)
- [Antenna Maintenance at ON5RR](#)
- [G4ERC, Rotary Yagi Array](#)
- [HB9SV and his Dish for 23 and 13 cm](#)
- [JA7BMB, 6m .5 f/D Dish, with feedmounted water cooled 7289 PA](#)
- [JA4BMB's feed and frontend](#)
- [W2VVV, 8 * 18 el M² Yagis on Ring Rotator and M² El Rotator](#)
- [DL6UW, 6 meter on 1296 MHz, the shack is in the 10 ft high army container](#)
- [DL6UW Dish plus mount](#)
- [RW3BP, 10 GHz EME, from an apartment in Moscow](#)
- [Close Up of Feed, LNA and HPA of 10 GHz antenna at RW3BP](#)
- [2 * 28 elements on a 9 wavelength boom at IK5QLO](#)
- [SV1BTR's 432 MHz Cross Yagi Array](#)
- [OH2DG, constructing a new Dish.](#)
- [QRP on 1296 MHz, TM8EME de PA3DZL.](#)
- [W6HD, 6 m Dish and 80 Watts at feed.](#)
- [DH9FAG, 3 m TVRO dish with 200 Watts and 0,35 NF.](#)
- [Dom, HB9BBD with his large dish for 1296 \(details later \)](#)
- [WE2Y and his YAGI Array on 432 MHz.](#)
- [9H1ES, 2 m Dish for 1296 MHz.](#)
- [JH4JLV and his antennas.](#)
- [6 * 36 el Long YAGI Array at DL3FI.](#)
- [The LU1296 Moonbounce Team, L-R LU6DW, LU4DHD and LU8EDR.](#)
- [Rotable dish feed by G3LTF.](#)
- [HB9SV, 16 Yagi 432 Array.](#)
- [KB4CNI, 8 * FO33 approx 28 dBi gain.](#)
- [HA5SHF with his 1296 antenna with feed .](#)
- [TVRO Dish at HA5SHF for 1296 MHz EME.](#)
- [N6BQ antenna party with WA6KBL and members of the 50UP group of N. Cal](#)
- [F1AHN, 1.8m Dish with 800 W at feed.](#)
- [OZ6OL in the shack.](#)
- [Dish at OZ6OL.](#)
- [Closeup of 432/1296 MHz feed at OZ6OL.](#)
- [W1ZX with a new and bigger dish.](#)

- [K6JEY, 4 * 25 el K1FO, ,4 dB, 500 Watts](#)
- [N2UO with his 1296 MHz dish](#)
- **Room for More Antenna Pictures.**

Antennae uploaded by FTP:

- [Shukon, 7M2PDT on 432 MHz with 8 x 25 elm. K1FO, TS790 and 8938 with 1.3 KW out.](#)
- [Scott, AC3A with 4 * M2 9E1 in a suburban , no towers, development.](#)
- [CT1DMK, Luis, 5.6m Dish for 1296 and 10 GHz.](#)
- [Guentner, DL4MEA on EME.](#)
- [4.5-m Russian Radar Dish Modified into 6.4-m Dish for 23 and 13 cm at OH2AXH.](#)
- [Ian, G3SEK and his 432 MHz 12 * 15el DJ9BV array with Rotatable Polarization.](#)
- [G4CCH, 1296 MHz dish antenna in yard](#)
- [G4CCH, watercooled 1296 HPA.](#)
- [G4CCH with a 5m homebrew Dish Project.](#)
- [G4DZU's 3m Dish, with VE4MA Scalar Feed and 500 W on 1296 MHz.](#)
- [G4DZU's in front of the Dish.](#)
- [Toshi, JR4BRS, 5.6m Dish for 23 and 13 cm.](#)
- [KB3PD, Yagi Array for 144 and 432 MHz.](#)
- [KD1DU, Del with 4 yagis for 144 MHz EME and much more on the tower](#)
- [KE7MK with 14 ft TVRO Dish, KB2AH feed and final with approx 100 W.](#)
- [Scott, KD4LT and his reflectors for 70 and 23 cm.](#)
- [Doug, K6JEY, with 4 * 25 el K1FO, .22 dB NF, and 1200 W from DM03wt](#)
- [Monica, KQ6PY tightening the hub bolts of a 5m Dish \(photo by WA6KBL\)](#)
- [Jeff, K7XQ with a bay of 4, just above the roof.](#)
- [Anders, LA8LF, with home built Dishes.](#)
- [ON5OF and his antennas](#)
- [Luc, ON6JY running a smaller Station.](#)
- [N6BQ, Ron on 1296 from the Bay Area](#)
- [NU7Z, 4 meter Dish for 1296 MHz through 10 GHz.](#)
- [Frank, W2UHI with 5.5m Dish at 23 cm.](#)
- [Don, W4RDI, 5.5 m, .5 F/D.](#)
- [SM2CEW, 8 m, 0.6 F/D, 432 and 1296 MHz, mesh-size good for future 2304 MHz.](#)
- [F3VS, 6 x 4 20 el DL9BV, submitted by Lean Marc Lair from REF magazine.](#)
- [SV1BTR, 4 x 11 wavelength, Cross H/V pol BVO on a non conductive boom.](#)
- [Ron, N6BQ on 1296 with a TVRO dish.](#)
- [DF4PV, Guenter with extended 6m TVRO Dish and 600 W on 1296.](#)

- [S57RA, bay of 4 YAGI's from the backyard for 70 cm. An anti aircraft gunmount as support.](#)
-
- [Parallel Wire Feeding of A Yagi System.](#)
-

Your antenna picture is welcome here as well.

Upload by Anonymous FTP to: nitehawk.com/pub/upload/rasmit/

[Another fine collection of EME antennas by Skukou, 7M2PDT](#)

[More EME Newsletter Content from Tom, K2AH](#)

Technical Articles and Information from Newsletter

- [K2AH shows the construction of 6 tube 23 cm Amplifiers.](#)
 - [1296 MHz Power Amplifier by K2AH.](#)
 - [PreAmps and PA's by Tom, K2AH.](#)
 - [From the Newsletter: Tom, K2AH on Tuning 1296 MHz Feedhorns.](#)
 - [Just for fun. \[Java Enabled Browser required \]](#)
 - [Simple preamps for 144 and 432 MHz by IK5QLO.](#)
 - [HB9BBD with moon signal recordings and a mighty fine Dish.](#)
-

More Antenna information found at links:

- [Elevation Solutions for Yagis By GM4JJJ.](#)
 - [From Europort, PA3EPD, semi-portable. Is this the future for many of us?](#)
-

FTP your antenna pictures to: nitehawk.com/pub/upload/rasmit

Please inform me by e-mail when you upload, thanks!

Preferred format: *.jpg.

[Top Page.](#)

[W6/PA0ZN](#)

07/04/95

[Order this information in Print](#)[Order this information on CD-ROM](#)[Download in PDF Format](#)[Click here to make tpub.com your Home](#)

Page Title: End-Fire arrays

[tpub.com Updates](#)

Page

[Back](#) | [Up](#) | [Next](#)

Web

www.tpub.com

[Back](#)[Up](#)[Next](#)

Broadside arrays Content Moved Parasitic arrays

[[Back](#)] [[Home](#)] [[Up](#)] [[Next](#)]

End-Fire Arrays

An end-fire array looks similar to a broadside array. The ladder-like appearance is characteristic of both (fig. 4-28, view A). The currents in the elements of the end-fire array, however, are usually 180 degrees out of phase with each other as indicated by the arrows. The construction of the end-fire array is like that of a ladder lying on its side (elements horizontal). The dipoles in an end-fire array are closer together ($1/8$ -wavelength to $1/4$ -wavelength spacing) than they are for a broadside array.

Figure 4-28. - Typical end-fire array.

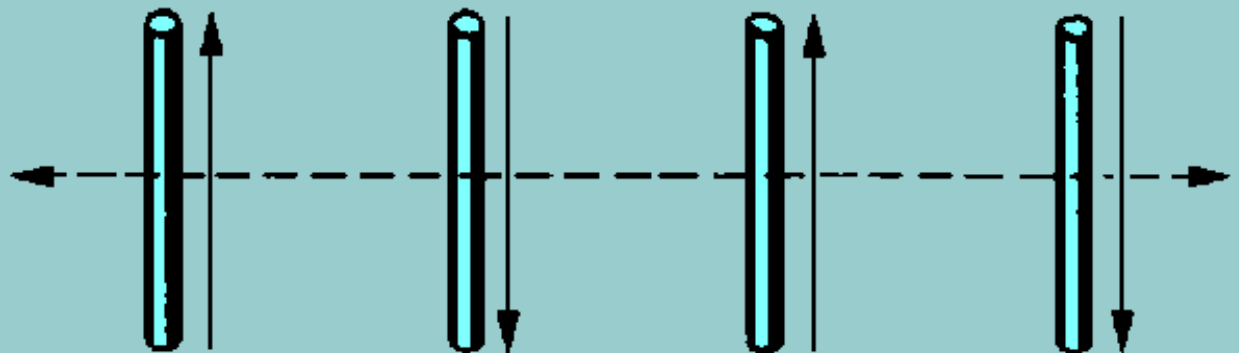

A. TOP VIEW OF ARRAY

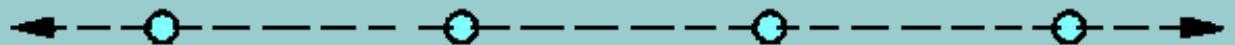

B. SIDE VIEW OF ARRAY

Closer spacing between elements permits compactness of construction. For this reason an end-fire array is preferred to other arrays when high gain or sharp directivity is desired in a confined space. However, the close coupling creates certain disadvantages. Radiation resistance is extremely low, sometimes as low as 10 ohms, making antenna losses greater. The end-fire array is confined to a single frequency. With changes in

climatic or atmospheric conditions, the danger of detuning exists.

RADIATION PATTERN. - The radiation pattern for a pair of parallel half-wave elements fed 180 degrees out of phase is shown in figure 4-29, view A. The elements shown are spaced $1/2$ wavelength apart. In practice, smaller spacings are used. Radiation from elements L and M traveling toward point P begins 180 degrees out of phase. Moving the same distance over approximately parallel paths, the respective wavefronts from these elements remain 180 degrees out of phase. In other words, maximum cancellation takes place in the direction of P. The same condition is true for the opposite direction (toward P1). The P to P1 axis is the line of least radiation for the end-fire array.

Figure 4-29. - Parallel elements 180 degrees out of phase.

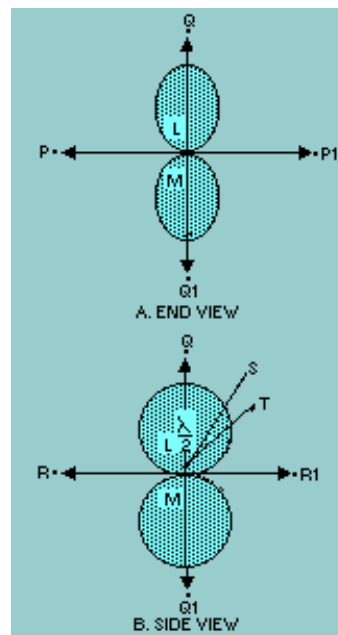

Consider what happens along the QQ1 axis. Energy radiating from element M toward Q reaches element L in about $1/2$ cycle (180 degrees) after it leaves its source. Since element L was fed 180 degrees out of phase with element M, the wavefronts are now in the same phase and are both moving toward Q reinforcing each other. Similar reinforcement occurs along the same axis toward Q1. This simultaneous movement towards Q and Q1 develops a bidirectional pattern. This is not always true in end-fire operation. Another application of the end-fire principle is one in which the elements are spaced $1/4$ wavelength apart and phased 90 degrees from each other to produce a unidirectional pattern.

In figure 4-29, view A, elements A and B are perpendicular to the plane represented by the page; therefore, only the ends of the antennas appear. In view B the antennas are rotated a quarter of a circle in space around the QQ1 axis so that they are seen in the plane of the elements themselves. Therefore, the PP1 axis, now perpendicular to the page, is not seen as a line. The RR1 axis, now seen as a line, is perpendicular to the PP1 axis as well as to the QQ1 axis. The end-fire array is directional in this plane also, although not quite as sharply. The reason for the greater broadness of the lobes can be seen by following the path of energy radiating from the midpoint of element B toward point S in view B. This energy passes the A element at one end after traveling slightly more than the perpendicular distance between the dipoles. Energy, therefore, does not combine in exact phase toward point S. Although maximum radiation cannot take place in this direction, energy from the two sources combines closely enough in phase to produce considerable reinforcement. A similar situation exists for wavefronts traveling toward T. However, the wider angle from Q to T produces a greater phase difference and results in a decrease in the strength of the combined wave.

Directivity occurs from either one or both ends of the end-fire array, along the axis of the array, as shown by the broken arrows in figure 4-28, view A; hence, the term *end-fire* is used.

The major lobe or lobes occur along the axis of the array. The pattern is sharper in the plane that is at right angles to the plane containing the elements (figure 4-29, view A). If the elements are not exact half-wave dipoles, operation is not significantly affected. However, because of the required balance of phase relationships and critical feeding, the array must be symmetrical. Folded dipoles, such as the one shown in figure 4-20, view A, are used frequently because the impedance at their terminals is higher. This is an effective way of avoiding excessive antenna losses. Another expedient to reduce losses is the use of tubular elements of wide diameter.

GAIN AND DIRECTIVITY. - In end-fire arrays, directivity increases with the addition of more elements and with spacings approaching the optimum. The directive pattern for a two-element, bidirectional system is illustrated in figure 4-29. View A shows radiation along the array axis in a plane perpendicular to the dipoles, and view B shows radiation along the array axis in the plane of the elements. These patterns were developed with a 180-degree phase difference between the elements. Additional elements introduce small, minor lobes.

With a 90-degree phase difference in the energy fed to a pair of end-fire elements spaced approximately $1/4$ wavelength apart, unidirectional radiation can be obtained. The pattern perpendicular to the plane of the two elements is shown in figure 4-30, view A. The pattern shown in view B, taken in the same plane, is for a six-element array with 90-degree phasing between adjacent elements. Since both patterns show relative gain only, the increase in gain produced by the six-element array is not evident. End-fire arrays are the only unidirectional arrays wholly made up of driven elements.

Figure 4-30. - Unidirectional end-fire arrays.

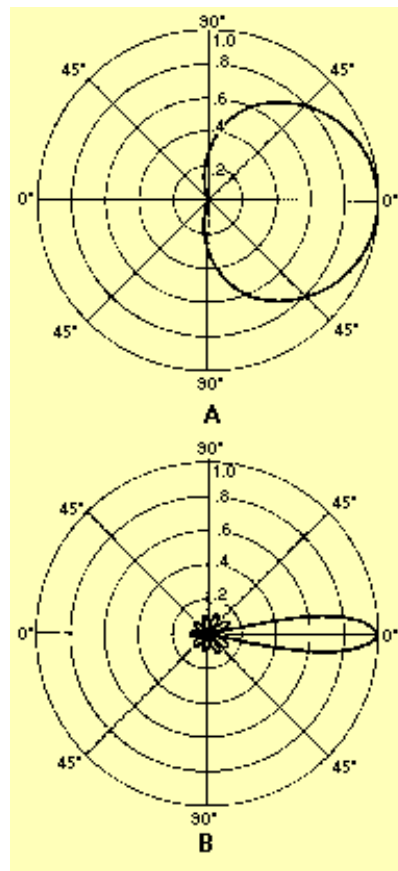

Q.35 What are some disadvantages of the end-fire array? **Answer**

Q.36 Where does the major lobe in the end-fire array occur? **Answer**

Q.37 To maintain the required balance of phase relationships and critical feeding, how must the end-fire array be constructed? **Answer**

[[Back](#)] [[Home](#)] [[Up](#)] [[Next](#)]

[Order this information in Adobe PDF Printable Format](#)

Dinner at Red Lobster on us!
Hungry? Answer a few questions...
...get a **\$50 Restaurant Card**



[Privacy Statement](#) - [Press Release](#) - [Copyright Information](#) - [Contact Us](#) - [Support Integrated Publishing](#)

[Home](#)

[Catalog Index](#)

[FAQ](#)

[Contact](#)

[View Cart](#)

[Check Out](#)

Battery Holders

[Scroll Back to Page 103](#)

Page 104

[Scroll Forward to Page 105](#)

D Cell



1-D Cell Solder Lugs
BH111.....\$1.00

QTY



2-D Cells Solder Lugs
BH121.....\$1.45

QTY



4-D Cells Solder Lugs
BH142.....\$1.80

QTY



8-D Cells Solder Lugs
BH181.....\$2.90

QTY

C Cell



1-C Cell Solder Lugs
BH211.....\$1.00

QTY



2-C Cells Solder Lugs
BH221.....\$1.40

QTY



4-C Cells Solder Lugs
BH243.....\$1.80

QTY



6-C Cells Solder Lugs
BH261.....\$2.10

QTY

AA Cell



1-AA Cell Solder Lug.
BH311.....\$0.75

QTY



2-AA Cells Snap Term.
BH321.....\$1.00

QTY



3-AA Cells Snap Term.
BH331.....\$1.10

QTY



4-AA Cells Snap Term.
BH341.....\$1.20

QTY

AA Cell



4-AA Cells Snap Term.



6-AA Cells Snap Term.



8-AA Cells Snap Term.



10-AA Cells Snap Term.

BH343.....\$1.20

QTY



3" Leads

BH9V6.....\$0.29

QTY

BH363.....\$1.40

QTY



6" Leads "T"

BH9VT.....\$0.29

QTY

9 Volt

BH383.....\$1.50

QTY



9-V Vertical Holder

BH9VH.....\$0.49

QTY

BH107.....\$2.55

QTY



9-V Horizontal Holder

BH9HH.....\$0.39

QTY

***We may substitute on terminal type, snap versus solder type.**

Properties of Fiber Glass Rods and Tubes

KQ6RH

(C) 1998, 1999, 2000

Ray Jurgens

(Up-Dated 2/25/2000)

Properties of Fiber Glass Rods and Tubes

At this point, I have obtained all of the fiberglass materials that have been using in my antenna projects from Max Gain Systems. These materials are all listed on their web page along with size, weight, color, and price. However, if you are planning to build light weight structures more information is probably required. In particular the bending properties associated with cantilever supports. The lightest weight material is the 1/8" rod, and an 8 ft length is easily bent into a full loop. Thus, this material can only support a small amount of weight at small lengths. The larger diameters of tubing can support increasing amounts of weight for a given deflection. The deflection information is particularly useful in predicting the total bending of a composite spreader and also for determining the amount of tension required in a guy line to re-establish specific position of the spreader.

The tables below give bending information for each of the rods and tubes I have tested. Each size of rod or tubing will bend a specific amount when loaded depending upon the size and length. These materials will also buckle when loaded axially. I concentrated mostly in determining the properties of the materials used as cantilever beams supported rigidly on one end in a horizontal position. Under this condition, the unsupported end will deflect downward due to the gravity load along the entire length of the beam. I measured the unloaded deflection as a function of length for each size material up to and including the 3/4" tubing. I also measured the 1/8" and 1/4" solid rods in the same manner. In general, all of these materials are formed from fiberglass of uniform density and modulus of elasticity, so the bending properties are predictable with a single equation. In general, the deflection increases with the cube of length for a given size and geometry. Further loading at the unsupported end increases the deflection in proportion to the loading, i.e., the lever acts as a linear spring about the rest position. This linear behavior is exhibited so long as the deflection angle is small (less than

about 15 degrees). An 8' span of the 1/8" rod material will deflect more than this angle, and the load no longer pulls perpendicular to the beam. For this reason, the smaller diameter materials are useful only in small lengths (as micro extensions). As an example, the table below shows the properties of the 1/2" tubing. Negative loading implies that the force is applied upward. Normally, I made some attempt to determine the amount of force required to bring the beam into horizontal position at the unsupported end.

| grams loading at end of beam | displacement in inches | Comments |
|------------------------------|------------------------|-------------------------|
| -160 | 0.00 | Negative loading at tip |
| 0 | 6.75 | No loading |
| 100 | 11.00 | Positive loading at tip |
| 200 | 16.50 | |
| 300 | 20.50 | |

Table 1
Deflection of 8' Cantilever Beam
0.5" OD 0.25 ID Tubing

It is clear from Table 1 that the useful range of loading is probably less than 200 grams for the 8' length. Further loading causes significant droop and such large distortions would be unable to support the wire beams in an acceptable manner. However, one way around this problem is to guy the beam into place. But, it may be more complicated to make a structure such that the beam is guyed from three or four sides. An other alternative is to deliberately bend the beam with a guy under tension from one direction such that this tension is much greater than the loading to be supported. This later procedure works well for making horizontal spreader structures for planar wire beams. The **Reflected M** beams pictured in that section are designed in this manner.

Table 2 below shows the deflection measurements for lengths of the 0.5" tubing for 2', 4' and 8' lengths supported horizontally and loaded at the free end. Note that some deflections were too small to measure, and some others were too large. In general the accuracy of the deflection measurement is limited to about an 1/8 of an inch, and the gram loading is accurate to about 5%.

| grams loading | 2' length deflection | 4' length deflection | 8' length deflection |
|---------------|----------------------|----------------------|----------------------|
| | | | |

| | | | |
|----------------------------|-------|-------|-------|
| -160 (pulling up to level) | | | 0.00 |
| -120 (pulling up to level) | | 0.000 | |
| 0 (unloaded) | 0.000 | 0.375 | 6.75 |
| 100 (pulling down) | | 1.250 | 11.00 |
| 200 | | 1.375 | 16.50 |
| 300 | 0.313 | 2.625 | 20.50 |
| 400 | | 3.500 | |
| 500 | 0.500 | 4.250 | |

Table 2
Deflection of 0.5" Diameter Tubing Under Loading for Various Lengths

At this point, it is probably best to try to make some sense of these measurements so that the standard equations for beam deflection and loading can be applied. Toward this end, several things are needed, and these include the weight per unit length of the materials, their second moments of inertia, and the modulus of elasticity. We have information on most of these except the latter item which is probably constant for the material. The deflection measurements permit us to get at this number using the deflection equation for uniformly loaded beams. If we let y be the downward deflection, then the equation is

$$y = w * L^4 / (8 * E * I)$$

where w is the weight per unit length (lbs/inch), L is the length (inches), E is the modulus of elasticity (lbs/inch²) and I is the moment of inertia (inches⁴). So, it is easy to see that we can solve for E given all the other parameters. Then, once we know E we can solve for deflections for many other cases. Table 3 is a summary of the data and resulting values of E determined for some of the smaller materials available. The value of the moment of inertia, I , can be calculated for these circular cross sections as

$$I = (\pi/4) * (R_o^4 - R_i^4)$$

where R_o is the outside radius and R_i is the inside radius (not diameters). If you use diameters in this equation, you need to divide the result by 16 to get the correct answer. The weights for these materials are located in the MGS home page, but they can be calculated quickly by multiplying the the density of the material by the cross sectional area. This gives the weight per

unit length. The density of these fiber glass materials is about 6.72×10^{-2} lbs/inch³ or roughly 1.86 grams/cm³. The white bicycle whip material in the table is about twice this dense (item # 3).

| # | Outside Dia | Inside Dia | Length | y displacement | l | w | E |
|------------|-------------|------------|--------|----------------|------------------------|-----------------------|--------------------------|
| | (inches) | (inches) | (feet) | (inches) | (inches ⁴) | (lbs / inch) | (lbs/inch ²) |
| 1 | 0.125 | 0.00 | 2.00 | 0.750 | 1.50×10^{-5} | 8.33×10^{-4} | 3.07×10^6 |
| 2 black | 0.250 | 0.00 | 4.00 | 2.375 | 2.44×10^{-4} | 3.23×10^{-3} | 3.69×10^6 |
| 3 white | 0.250 | 0.00 | 4.00 | 1.750 | 2.44×10^{-4} | 6.43×10^{-3} | 1.00×10^7 |
| 4 | 0.375 | 9/64 | 4.00 | 1.250 | 1.89×10^{-3} | 6.72×10^{-3} | 3.02×10^6 |
| 5 | 0.500 | 9/64 | 8.00 | 6.750 | 3.69×10^{-3} | 8.72×10^{-3} | 3.71×10^6 |
| 6 | 0.500 | 9/64 | 4.00 | 0.375 | 3.69×10^{-3} | 8.72×10^{-3} | 3.70×10^6 |
| 7 | 0.750 | 0.500 | 8.00 | 3.750 | 1.59×10^{-2} | 1.56×10^{-2} | 2.78×10^6 |

Table 3
Determination of Modulus of Elasticity from Deflection Measurements

Notice that the value of E is around 3×10^6 psi for all of the black fiber glass samples, but there is some variation that may indicate slight differences in the material. However, using a value near 3×10^6 will provide a good first estimate for engineering purposes, and the variation in the table can be used as an estimate of the expected variance. Note that the white bicycle whip

material is very different. It is twice as dense as the other materials in the table and has a modulus of elasticity that is 3 times as high (about equal to that of aluminum) as the other samples. The E values for the fiber glass are about 1/10 as large as structural steel (for perspective).

The tables that follow are measurements of loading applied to the ends of the horizontal cantilevers. So as long as the displacements are small, the beams respond as linear springs so that the displacement about the quiescent displacement is proportional to the applied load. So we can assume that $y = K \cdot W$ where W is the applied load. The spring constant, K , can be derived from the moment diagram of the loading, however, it may be adequate to know the dependence on the length of the beam is as $K \sim L^3/(E \cdot I)$, so the spring is very stiff for short lengths and gets loose rapidly as the length of the beam increases. So, $y \sim L^3 \cdot W / (E \cdot I)$, and you can find the constant of proportionality for the data in the tables so that you can use W in what ever units you like. Also, note, the 0.5" tubing is given in Table 2 and is not repeated here.

| L length in feet | W grams weight applied | Displacement inches |
|------------------|------------------------|---------------------|
| 2 | 0 | 0.75 |
| 2 | 50 | 10.00 |

Table 4
Displacement for 1/8" Diameter Solid Fiber Glass Rod

| L length in feet | W grams weight applied | Displacement in inches |
|------------------|------------------------|------------------------|
| 2 | 0 | ~0 |
| 2 | 100 | 1.75 |
| 2 | 200 | 3.00 |
| 2 | 300 | 4.50 |
| 4 | 0 | 2.37 |
| 4 | 100 | 15.50 |
| 5' 8" | 0 | 11.50 |
| 5' 8" | 50 | 28.00 * beyond linear |

Table 5
Displacements for 1/4" Solid Black Fiber Glass

| L length in feet | W grams weight applied | Displacement in inches |
|------------------|------------------------|------------------------|
| 4 | 0 | 1.75 |
| 4 | 100 | 9.50 |
| 4 | 200 | 15.25 |
| 4 | 300 | 19.75 |
| 5' 8" | 0 | 6.00 |
| 5' 8" | 50 | 20.00 |
| 5' 8" | 100 | 24.50 |

Table 6
Displacements for 1/4" Solid White "Fiber Glass ?"

| L length in feet | W grams weight applied | Displacement in inches |
|------------------|------------------------|---------------------------|
| 2 | 0 | ~0 |
| 2 | 100 | 0.375 |
| 2 | 200 | 0.625 |
| 2 | 300 | 0.875 |
| 2 | 400 | 1.125 |
| 2 | 500 | 1.500 |
| 4 | 0 | 1.250 |
| 4 | 100 | 4.250 |
| 4 | 200 | 6.375 |
| 4 | 300 | 8.500 |
| 8 | 0 | 13.625 |
| 8 | 100 | 29. * beyond linear limit |

Table 7
Displacements for 3/8" Fiber Glass Tubes

| L length in feet | W grams weight applied | Displacement in inches |
|------------------|------------------------|------------------------|
| 4 | 0 | ~0 |
| 4 | 100 | 0.250 |
| 4 | 200 | ? got lost |
| 4 | 300 | 1.000 |
| 8 | 0 | 3.750 |
| 8 | 100 | 5.500 |
| 8 | 200 | 7.875 |
| 8 | 300 | 9.875 |

Table 8
Displacements for 3/4" Fiber Glass Tubes

These tables are useful in determining the displacements of the beams when loading is applied and can be useful for estimating deflections when the supports are at differing angles, such as 45 degrees. In general, one should consider the wire load carefully, and choose materials strong enough to carry the load without serious distortion to the structure. The structures can be made more stable by using nylon monofilament guy lines, however, buckling, and other problems might appear if the guys or wires are too tight. Since the displacements depend upon the length cubed when loads are applied at the tips, the total displacement of compound or telescoping sections can be estimated from the tables above. More information on these topics will be added from time to time.

I have recently spent some time testing kevlar thread in place of the monofilament nylon fish line. This material is very strong and hardly stretches at all. However, this very property can also be a problem in getting the loading distributed equally in the various guy lines. This also means that the lengths must be measured and cut very exactly, and one must know exactly what length to cut. In systems with multiple guy lines, tension on one line affects the others, i.e., all parts of the structural system are coupled. Since these systems present considerable computational difficulty, you can save a lot of grief by including a small turnbuckle in each line. This allows individual adjustment of the tensions. The turnbuckles should be placed at the ends of the guys at the most stable point (for example the guy post). Alternatively, separate guy tie rings can be used for each guy set allowing adjustment of individual guy sets. This second method usually is lighter in weight. You should take care that each guy set is made with

identical lengths even though the actual lengths can depart slightly from those calculated.

The 1/8" material is useful for short extenders for either the 1/4" or 3/8" tubes. I found that terminal lugs can be crimped on to the 1/8" inch rods and grommets inserted to provide a wire guide. The wires can be secured in proper location using a 4" piece of #18 copper wire twisted around the lug and then to either side of the wire.



1/8" Extenders with Crimp Lugs

[Return to Main Menu](#)



Flags and Pennants

Receive antennas for limited space with good noise rejection like the Ewe. They are ground independent, too, a big plus!

Here is a compendium of information about these excellent low-noise receive antennas. The Pennant was originated by EA3VY and optimized for 160 meters by K6SE, who first wrote about them on the [Top Band Reflector](#) in 1998. It also performs very well on 80 and 40 meters. I built a Flag antenna pointed at Europe and was pleased with the results. I plan to build more of them. K6SE has done a great job in refining and popularizing these antennas. JF1DMQ actually wrote an [earlier article](#) about the Flag antenna in November 1995 in a Japanese magazine. His was only 3.3 feet by 16.4 feet long (1 by 5 m). K6SE's 160m optimized versions are 14 by 29 feet (4.3 by 8.8m).

-- Updated 26 Mar 2002 --

New [Pennant Antenna With Remote Termination Control](#) by WA1ION

New [Reduced Size and Elevated Flag Antenna Models](#) by VE6WZ

See **QST Magazine**, July 2000, page 34 for K6SE's article:

"Flags, Pennants, and Other Ground-Independent Low-Band Receiving Antennas"

[Basic Pennant Description](#)

[More Basic Information](#)

[More Basic Information](#)

[Size, Pattern, Termination](#)

[Basic Information Q&A](#)

[G4VGO Reports](#)
[Good Results](#)

[Elevation Angle,](#)
[Multi-Antenna Interaction](#)

[Antenna/Mast](#)
[Interaction](#)

[Minimizing Interaction](#)
[With TX Verticals](#)

[TX Vertical Interaction,](#)
[Transformer Details](#)

[Switching Multi Antennas-](#)
[Point-Fed Pennant Is Best](#)

[Multi Antennas- Regular](#)
[Coax Switches NOT OK](#)

| | | |
|---|--|--|
| <u>Performance Compared to Beverages, Phased Vert</u> | <u>Matching Transformer Theory</u> | <u>Final Consensus On Transformer Design?</u> |
| <u>More Transformer Design, TX Vertical Interaction</u> | <u>Effect Of Termination Resistance On F/B Ratio</u> | <u>Termination Res Critical To Good Noise Rejection</u> |
| <u>EA3VY Magazine Article, Design Comments</u> | <u>W7IUV's Rotary Flag</u> | <u>Diamond Configuration</u> |
| <u>Signal Output Is Low But Performance is Good</u> | <u>Importance of F/B Ratio</u> | <u>Termination Res & F/B, More Transformer Notes</u> |
| <u>More Transformer Theory</u> | <u>More Transformer Theory</u> | <u>More Transformer Theory</u> |
| <u>More Transformer Theory</u> | <u>More Transformer Theory</u> | <u>Pennant & Flag Arrays</u> |
| <u>Phasing Loop Arrays</u> | <u>Phasing Loop Arrays</u> | <u>Phasing Loop Arrays</u> |
| <u>Antenna Comparisons- Very Informative!</u> | <u>Flag Antenna User Report</u> | <u>W8JI Flag Comments</u> |
| <u>K6SE Comments on Rotary Flag</u> | <u>Delta RX Antenna</u> | <u>JF1DMQ Flag Predecessor</u> |
| <u>Flag Performance Deterioration</u> | <u>Delta RX Disappointment</u> | <u>Pennant Remote Termination Control</u> |
| <u>Pennant Working?</u> | <u>Pennant Preamps</u> | <u>Pennant Preamps</u> |
| <u>Pennant Preamps</u> | <u>W7IUV Compares Low Noise Antennas</u> | <u>Room for 4 Pennants- Part 1</u> |
| <u>WA1ION & K6SE Q&A</u> | <u>K9AY Comments</u> | <u>Room for 4 Pennants- Part 2</u> |

[HOME](#)

[K3KY's DX Toolbar](#)

[The Low Bands](#)

[PREV](#)

057482

Folded Dipoles

A variation of the dipole is an antenna called a folded dipole. It radiates like a dipole but sort of looks like a **squashed** quad.

Having a folded dipole does **not** mean that you have an antenna that is folded in half and so you obtain an antenna that now takes up half the space of a regular dipole. No, the antenna is still approximately the same length as a regular dipole. It *is* however, an antenna that has a wire folded back over itself, hence its name. Below is a picture of a folded dipole.

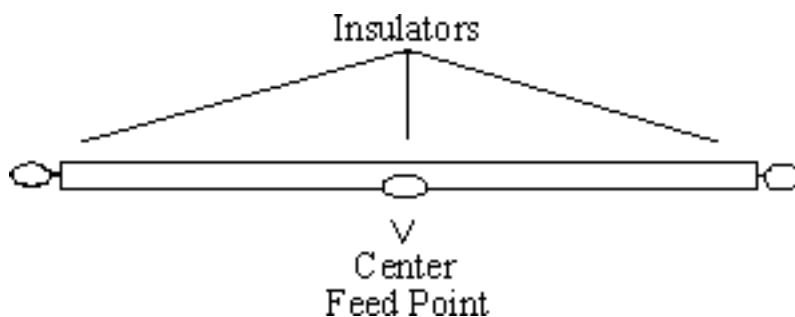

The starting formula for the folded dipole calculation is the same as a dipole, $468 / \text{Frequency (in MHz)}$. Let's try an example: Design a folded dipole for the 40 meter band. The frequency that is chosen might be 7.15 MHz. Plugging this in to the formula ($468 / 7.15$) gives a folded dipole with a length of 65.45 feet. When I modeled a dipole on the computer at 30 feet, I came up with a length of 65.47 feet. When I added a second wire to make the folded dipole shown above, I designed the antenna with 1 inch spacing between the two wires. Note that this adds 1 more inch to each of the two antenna wires over that of a single wire dipole. This plus the fact that we are actually turning up the ends of the antenna, means that the horizontal length actually need to be a little shorter to be once again at resonance. The total length came to 64.38 feet, 1.09 feet shorter than the straight dipole. If you use a greater spacing, say 1 foot between the wires the length is 63.1 feet, 2.37 feet shorter. So be sure to shorten the antenna a bit or you'll find yourself operating lower down the band than you expected.

The feed point impedance is also modified by the second wire. Let's say the original dipole was 72 ohms. The step-up for a two wire folded dipole is 4 times which means $4 * 72 = \sim 288$ ohms. (The computer shows 281 ohms on my example, but remember, we reduced the length slightly also.) This step up continues if you add more and more wires. A three wire antenna would provide a step-up of 9, and a four wire antenna provides a step-up of 16.

We can see why this step-up occurs by looking at the power formula $P = (I^2) * R$, this can be rewritten as $R = P / (I^2)$. If the power to a regular dipole antenna was 100 watts and the current was 1.2 amps, we'd solve for R as $R = 100 / (1.2^2)$, which is the same as $R = 100 / 1.44$, which is 69.44 ohms. In the folded dipole the wires are in parallel, the current must be divided between the two wires. The current in each is half and the total power has not changed, so now the formula is $R = 100 / (.6^2)$, which is the same as $R = 100 / .36$, which of course is 277.77 ohms, 4 times the normal dipole antenna.

So now you ask, why would anyone want an antenna with a feed point impedance of 277 ohms, my coax cable is 50 ohms!? Well let's say you wanted to feed the antenna, not with 50 ohm cable but with 300 ohm twin lead? Ah ha, now we have a decent match and a feed line that can also handle a higher SWR with low loss. You'd probably use a tuner (ATU) in the shack to match the 50 ohm radio to the 300 ohm feed line. You could also use the antenna on other bands with the tuner and have an efficient antenna system.

What are the drawbacks to the antenna? Well for one, the currents on each wire will begin to cancel each other out on even multiples of the *cut* frequency, so a 40 meter folded dipole should not be used on 14 MHz. On other bands even though the signal may cancel broad side to the antenna, you'll find that there is actually gain! This occurs about 45 degrees off broad side to the antenna. And this might make for interesting contacts.

[Back to the Antenna Elmer](#)

[Back to the home page](#)

All trademarks mentioned belong to their respective owners.

The content on this page is provided as is, and should be accepted and used without expecting any particular fitness for any particular purpose. No liability is assumed with respect to the use of this information.

© Copyright 1996 – 97 Edward Oros and Bob Cocco



Homebrew Antennas

[YLRADIO Home](#)

[What is a Ham?](#)

[Becoming a Ham](#)

[What Now?](#)

[Emergency Prep.](#)

[Amateur Radio Nets](#)

[Amateur Radio Links](#)

[HF & Morse Operations](#)

[DX Propagation Tools](#)

[Homebrew Antennas](#)

[YL Stories](#)

[IRLP](#)

[BCYLARA News](#)

[YL DXpedition News](#)

[YL Conferences](#)

[Full Wave Delta Loop](#)

[2 Meter Dipole Antenna](#)

[Portable 3-Band Yagi](#)

[Portable 6M Antennas](#)

FULL WAVE LOOP ANTENNA

(Plus Halyard Building Instructions)

Are you looking for an inexpensive wire antenna that makes possible HF operation on all bands 10M through to 80M with wide bandwidth?

If yes, you may want to consider putting up this **Delta Loop** like Elizabeth, VE7TLK did on her single residential lot, with the help of amateur radio friends. Antenna apex is up approximately 82' tied to a cedar tree, while the two corners are tied to a shorter tree 25' high and a carport roof.

This Delta Loop is a three-sided antenna suspended high in the air by vertical supports, such as tall evergreen trees. Recommended height is 40 feet or more at highest point, but higher is better. It's one feed line eliminates the need for multiple antennas to cover the HF bands.

Diagram

The Delta Loop's feedpoint is located near one of the bottom corners providing a slight increase in gain and easy access when maintenance is required.

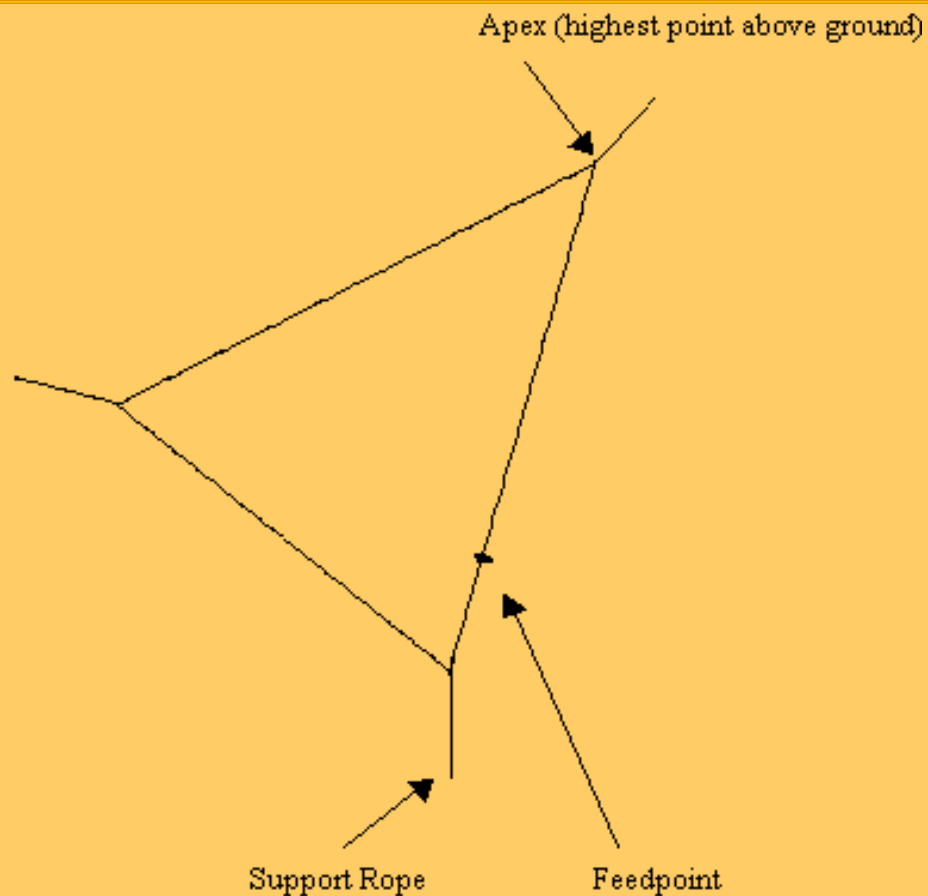
[CLARA](#)[YLS Worldwide](#)[Video Clips!](#)[Archives](#)

Directional Characteristics

The radiating element or wire position in relation to the ground determines polarization. If the wire is parallel to the ground, it radiates horizontally. If the wire is perpendicular to the ground, it radiates a vertical wave. If the wire is slanted, it radiates waves, which have both horizontal and vertical qualities.

Calculating Length Of Wire Needed For 80 M Loop

$$\text{Length (ft.)} = \frac{1005}{f \text{ (MHz)}}$$

Therefore, length of wire needed for an 80M loop antenna is:

$$\text{Length (ft.)} = \frac{1005}{3.7\text{MHz}} = 272 \text{ feet}$$

Materials Needed For Antenna

- Copper Stranded Wire #12
- 4 ceramic or glass insulators (apex, two corners, and at feedpoint)
- RG58 or mini RG8 Coax (50 ohm) Calculate length from feed line to radio room plus a little extra.
- PL259 Connector (UHF male) - for end of coax which connects to radio.
- Support rope for corners and apex.
- Roll of coax seal to wrap.
- Polyester braided rope (3/8") needed for halyard and support ropes.

Step By Step Instructions

1. Draw to scale diagram of antenna and all supports with dimensions on lot.
2. Measure and cut wire length for antenna allowing 1' extra for securing insulators. Careful not to bend wire.
3. Lay the wire on the ground so that the sides can be measured and the insulators fixed to the apex and corners. To fix insulator cut a short piece of wire and twist it around the antenna wire for about 4" on one side and then cross over insulator end and repeat 4" up the other wire. This adds strength to the corners and apex and keeps insulators in place when raising antenna.
4. Cut three pieces of support rope to clear and free antenna corners and apex from trees/buildings, etc. Connect ropes to the three insulators.
5. Feedpoint connection $\frac{1}{4}$ wavelength from bottom corner. (See diagram) With a sharp knife, carefully strip back (not cut) 3" of the exterior black jacket from one end of the 50 ohm coax being careful not to score the braid underneath. Pull the braid gently a part in one place and pull out the inner dielectric containing the center conductor. The coax is now split in two. Expose the center conductor by carefully cutting off 1" of the inner dielectric which is covering the center conductor.
6. Each wire end is then threaded through the closest insulator hole and then tightly twisted around antenna wire on that end. This is also repeated on the other end of the same insulator using the other antenna wire. Wrap prepared coax end around the middle of the insulator and secure with a clamp.
7. Once this is done and the materials have been cleaned

well, solder one of the #12 gauge copper wires to braid and the other to the center conductor. To avoid water and contamination in the feed line, the antenna end of the feed line must be adequately covered with coax seal .

Remember, the feed line connection at the center insulator should not be done until after the antenna wire has been tied securely to the insulator.

8. Construct a 1:1 broadband balun. Wind or coil a length of coaxial feed line for 6-8 turns near point of connection and secure with electrical tape. Lengths are not critical. Diameter of coils approximately 8".
9. Pull the antenna wire carefully up in the air by pulling down on the rope end which will eventually be tied to the limb of the tree. Once desired height of highest corner or apex has been reached, tie rope to limb near ground and within reach by a ladder.
10. One of the two remaining insulators will have its rope now tied to the second tree (or other support) which also has a collar but no pulley. This insulator and the previous one are counterweighted (halyard) and allowed to move freely.
11. The delta loop is now ready to be raised using the pulley on the halyard at the top of the tree or pole. Once the apex is fastened at the correct height proceed to fasten securely the corner ropes to their tie supports.
12. Install the PL259 (UHF male) Connector on end of coax feedline in radio room. An adapter is available if using the smaller RG-58 size coax. Connect to transceiver and test for SWR.

Halyard Recommended

Introduces slack so that during high wind conditions the wire loop can move, thus reducing stress on wire avoiding breakage. See directions for making halyard.

Materials And Directions

1. Bucket (with several holes on bottom) with handle plus counterweight weighted with bricks or sand and rocks.
2. One pulley large enough for line to run through freely keeping in mind that rope can swell when wet. Buy a fast-eyed brass or bronze marine type pulley.
3. Polyester braided rope (3/8") needed to go up and down

full length of tree trunk from collar to ground. Allow for extra to tie around lower limb and to raise antenna without running out of rope.

4. Make a trunk collar to protect bark of tree. This is done by threading a short piece of rope through an old hose or other soft tubing, the diameter of the trunk, where the collar will be positioned up high on the tree. Thread the pulley onto collar rope where the two ends of collar will meet together and tie securely. Only an experienced tree climber, with safety climbing equipment, should do the climbing.
5. While climber is up on the tree have him take one end of the long rope and feed it through the pulley. As he comes down he can pull that end down with him to ground level. Do not cut rope yet until after the antenna has been raised up, otherwise you may find yourself with too short a rope.
6. One end of rope will be tied to the weighted bucket handle and the other end tied tightly to a low limb within your reach. Bucket should be suspended about six feet from ground floating freely. The antenna wire at this point is still lying on the ground.
7. Just before the antenna wire is ready to be raised, tie the appropriate support short rope to the insulator at the apex of the antenna to the halyard rope's mid-point. This rope enables the wire to position itself away from tree branches.
8. Raise the apex of the antenna by pulling on the rope without the bucket tied to it to the desired height. Then tie rope securely to one of the lower limbs within reach.

Grounding Antenna & Radio

Materials Needed

- 8 Feet Copper Ground Rods (1 to 3) five to six feet apart (?)
- Brass clamps (for each rod)
- Belden grounding braid or 2" copper ribbon
- Good Power Bar with filter and surge protector
- Copper Bar attached to back of station table-top

Take the next step and operate DX!



[Back to Top](#)

[DX Propagation Tools](#) [YL Stories](#)

Content & Technical Manager: ylradio@qsl.net.
[Click here](#) for website credits.

1999 - 2003

**FUTURE HOME OF A
DOTSTER REGISTERED DOMAIN.**

CHOOSE A DOMAIN NAME - \$14.95 DOMAINS



Featured Partners

Scripts : Webmaster Resources : Webmaster Forum : Open Source : GiftTree Gifts : Fantastic Flowers : Gift Shopping : Free HTML Tutorials :
WebSite Hosting : Free Javascripts : Webmaster Resources : Free Web Hosting : Web Page Hosting : Cheap Web Hosting : .ca canadian domains :
MP3 and Polyphonic Ringtones

Join Now!

Web Site Hosting | Free URL Forwarding | Online Security | NameWinner | Aftermarket Domain Names | E-Commerce Solutions
| Domain Name Registration | Free Web promotion | Free Web Hosting | Deleted Domains | Analytical Laboratories | Online
Shopping

G5RV Multi-Band Antenna

by Louis Varney,

CEng, MIEE, AIL, G5RV

* taken from (RADIO COMMUNICATIONS, JULY 1984)

THE G5RV ANTENNA, with its special feeder arrangement, is a multiband centre-fed antenna capable of very efficient operation on all hf bands from 3.5 to 28mhz, specifically designed with dimensions which allow it to be installed in gardens which accommodate a reasonably-straight run of about 102ft (31.1m) for the "flat-top". However, because the most useful radiation from a horizontal or inverted-V resonant antenna takes place from the center two-thirds of its total length, up to one-sixth of this total length at each end of the antenna may be dropped vertically, semi-vertically, or bent at some convenient angle to the main body of the antenna without significant loss of effective radiation efficiency. For installation in a very limited space, the dimensions of both the "flat-top" and the matching section can be divided by a factor of two to make the half-size G5RV, which is a very efficient antenna from 7 to 28 mhz. The full-size G5RV will also function on 1.8mhz band if the station end of the feeder (either balanced or coaxial-type) is strapped and fed by a suitable antenna tuner using a good earth connection or a counterpoise wire. Similarly, the half-size version may be used thus on 3.5 and 1.8 mhz bands.

In contradistinction to multiband antennas in general, the full size G5RV antenna was not designed as a half-wave dipole on the lowest frequency of operation, but as a 1 1/2 wave centre-fed long-wire antenna on 14mhz, where the 34ft (10.36m) open-wire matching section functions as a 1:1 impedance transformer, enabling the 75ohm twinlead or 50/80ohm coaxial cable feeder to "see" a close impedance match on that band with a consequently low vswr on the feeder. However, on all the other hf bands the function of this section is to act as a "make-up" section to accommodate that part of the standing-wave (current and voltage components) which, on certain of the operating frequencies, cannot be completely accommodated on the "flat-top" (or inverted-V) radiation portion. The design centre frequency for the full-size version is 14,150khz, and the dimensions of 102ft (31.1m) is derived from the formula for long-wire antennas which is:

$$\text{Length (ft)} = \frac{492 (n - 0.05)}{f \text{ MHz}} = \frac{492 \times 2.95}{14.15} = 102.57 \text{ft (31.27m)}$$

where n= number of half-wavelengths of the wire (flat-top).

In practice, since the whole system will be brought to resonance by the use of an antenna tuner, the antenna is cut to 102ft (31.1m).

As it does not make use of traps or ferrite beads, the "dipole" portion becomes progressively longer in electrical length with increasing frequency.

This effect confers certain advantages over a trap or ferrite-bead loaded dipole because, with increasing electrical length, the major lobes of the vertical component of the polar diagram tend to be lowered as the operating frequency is increased. Thus, from 14mhz up, most of the energy radiated in the vertical plane is at angles suitable for dx working. Furthermore, the polar diagram changes with increasing frequency from a typical half-wave dipole pattern at 3.5mhz

and a 2 1/2 wave in-phase pattern at 7 and 10mhz to that of a "long-wire" antenna at 14, 18, 21, 24 and 28mhz.[Figure 1.](#)

Although the impedance match for 75 ohm twinlead or 80 ohm coaxial cable at the base of the matching-section is very good at 14mhz, and even the use of 50 ohm coax cable results in only about 1.8:1 vswr on this band, the use of a suitable antenna tuner is necessary on all the other hf bands because, on those bands, the antenna plus the matching-section will present a reactive load to the feeder. thus the use of the correct type of antenna tuner (unbalanced input to balanced output if twin-wire feeder is used, or unbalanced to unbalanced if coaxial feeder is used) is essential in order to ensure the maximum transfer of power to the antenna from a typical transceiver having a 50 ohm coaxial (unbalanced) output. Also to satisfy the stringent load conditions demanded by such modern equipment employing an alc system which "senses" the vswr condition presented to the solidstate transmitter output stage so as to protect it from damage which could be caused by a reactive load having a vswr of more than about 2:1.

[Figure 2](#)

The above reasoning does not apply to the use of the fullsize G5RV antenna on 1.8mhz, or to the use of the half-size version on 3.5 and 1.8mhz. In these cases the station end of the feeder conductors should be "strapped" and the system tuned to resonance by a suitable series-connected inductance and capacitance circuit connected to a good earth or counterpoise wire. Alternately, an "unbalanced-to-unbalanced" type of antenna tuner such as a "T" or "L" matching circuit can be used. Under these conditions the "flat-top" (or inverted-V) portion of the antenna plus the matching section and feeder function as a "Marconi" or "T" antenna, with most of the effective radiation taking place from the vertical, or near vertical, portion of the system; the "flat-top" acting as a top-capacitance loading element. However, with the system fed as described above, very effective radiation on these two bands is obtainable even when the "flat-top" is as low as 25ft (7.6m) above ground.

Theory of Operation

The general theory of operation has been explained above; the detailed theory of operation on each band from 3.5 to 28mhz follows, aided by figures showing the current standing wave conditions on the "flat-top" and the matching (or make-up) section. The relevant theoretical horizontal plane polar diagrams for each band may be found in any specialized antenna handbooks. However, it must be borne in mind that: (a) the polar diagrams generally shown in two dimensional form are, in fact, three dimensional (ie solid) figures around the plane of the antenna; and (b) all theoretical polar diagrams are modified by reflection and absorption effects of near-by conducting objects such as wire fences, metal house guttering, overhead electric power and telephone wires, house electric wiring system, house plumbing systems, metal masts and guy wires, and large trees. Also the local earth conductivity will materially affect the actual polar radiation pattern produced by an antenna. Theoretical polar diagrams are based on the assumptions that an antenna is supported in "free space" above a perfectly conducting ground. Such conditions are obviously impossible of attainment in the case of typical amateur installations. What this means in practice is that the reader should not be surprised if any particular antenna in a typical amateur location produces contacts in directions where a null is indicated in the theoretical polar diagram and perhaps not such effective radiation in the directions of the major lobes as theory would indicate.[Figure 3](#)

3.5Mhz. On this band each half of the "flat-top" plus about 17ft (5.18m) of each leg on the matching-section forms a fore-shortened or slightly folded up half-wave dipole. The remainder of the matching-section acts as an unwanted but unavoidable reactance between the electrical centre of the dipole and the feeder to the antenna tuner. The polar diagram is effectively that of a half-wave antenna. See [figure 1.](#)

7Mhz. The "flat-top" plus 16ft (4.87m) of the matching section now functions as a partially-folded-up "two half-wave in phase" antenna producing a polar diagram with a somewhat sharper lobe pattern than a half-wave dipole due to its colinear characteristics. Again, the matching to a 75 ohm twinlead or 50/80 ohm coaxial feeder at the base of the matching section is degraded somewhat by the unwanted reactance of the lower half of the matching section but, despite this, by using a suitable antenna tuner the system loads well and radiates very effectively on this band. See [figure 2](#).

10Mhz. On this band the antenna functions as a two half-wave in-phase colinear array, producing a polar diagram virtually the same as on 7mhz. A reactive load is presented to the feeder at the base of the matching section but, as for 7mhz, the performance is very effective. See [figure 3](#).

14Mhz. At this frequency the conditions are ideal. The "flat-top" forms a three-half-wave long centre-fed antenna which produces a multi-lobe polar diagram with most of its radiated energy in the vertical plane at an angle of about 14 degrees, which is very effective for dx working. Since the radiation resistance at the centre of a three-half-wave long-wire antenna supported at a height of half-wave above ground of average conductivity is about 90 ohm, and the 34ft (10.36m) matching section now functions as a 1:1 impedance transformer, a feeder of anything between 75 and 80 ohm characteristic impedance will "see" a non-reactive (ie resistive) load of about this value at the base of the matching section, so that the vswr on the feeder will be very nearly 1:1. Even the use of 50 ohm coaxial feeder will result in a vswr of only about 1.8:1. It is here assumed that 34ft (10.36m) is a reasonable average antenna height in amateur installations. See [figure 4](#).

18Mhz. The antenna functions as two full-wave antennas fed in phase; combining the broadside gain of a two-element colinear array with somewhat lower zenith angle radiation than a half-wave dipole due to its long-wire characteristic. See [figure 5](#)

21Mhz. On this band the antenna works as a "long-wire" of five half-waves, producing a multilobe polar diagram with very effective low zenith angle radiation. Although a high resistive load is presented to the feeder at the base of the make-up section, the system loads very well when used in conjunction with a suitable antenna tuner and radiates very effectively for dx contacts. See [figure 6](#).

24Mhz. The antenna again functions effectively as a five-half-wave "long-wire" but, because of the shift in the positions of the current anti-nodes on the flat-top and the matching section, as may be seen from [figure 7](#), the matching

or "make-up" section now presents a much lower resistive load condition to the feeder connected to its lower end than it does on 21mhz. Again, the polar diagram is multilobed with low zenith angle radiation.

28Mhz. On this band, the antenna functions as two "long-wire" antenna, each of three half-waves, fed in-phase. The polar diagram is similar to that of a three half-wave "long-wire" but with even more gain over a half-wave dipole due to the colinear effect obtained by feeding two three-half-wave antennas, in line and in close proximity, in-phase. See [figure 8](#).

Construction

The Antenna

The dimensions of the antenna and its matching section are shown in [Figure 9](#). The "flat-top" should, if possible, be horizontal and run in a straight line, and should be erected as high as possible above ground. In describing the theory of operation, it has been assumed that it is generally possible to erect the antenna at an average height of about 34ft (10.36m), which happens to be the optimum radiation efficiency on 1.8, 3.5 and 7mhz for any horizontal type antenna, in practice few amateurs can install masts of the optimum height of half a wavelength at 3.5 or 7mhz, and certainly not at 1.8mhz.

If, due to limited space available, or to the shape of the garden, it is not possible to accommodate the 102ft (31.1m) top in a straight line, up to about 10ft (3m) of the antenna wire at each end may be allowed to hang vertically or at some convenient angle, or be bent in a horizontal plane, with little practical effect upon performance. This is because, for any resonant dipole antenna, most of the effective radiation takes place from the centre two-thirds of its length where the current antinodes are situated. Near to each end of such an antenna, the amplitude of the current standing wave falls rapidly to zero at the outer extremities; consequently, the effective radiation from these parts of the antenna is minimal.

The antenna may also be used in the form of an inverted-V. However, it should be borne in mind that, for such a configuration to radiate at maximum efficiency, the included angle at the apex of the V should not be less than about 120 degrees. The use of 14awg enameled copper wire is recommended for the flat-top or V, although thinner gauges such as 16 or even 18awg can be used.

The Matching Section

This should be, preferably, of open-wire feeder construction for minimum loss. Since this section always carries a standing-wave of current (and voltage) its actual impedance is unimportant. A typical, and very satisfactory, form of construction is shown in [figure 10](#). The feeder spreaders may be made of any high-grade plastic strips or tubing; the clear plastic tubing sold for beer or wine siphoning is ideal.

If it is desired to use 300 ohm ribbon type feeder for this section, it is strongly recommended that the type with "windows" be used because of its much lower loss than that with solid insulation throughout its length, and its relative freedom from the "detuning" effect caused by rain or snow. If this type of feeder is used for the matching section, allowance must be made for its velocity factor (vf) in calculating the mechanical length required to resonate as a half-

wave section electrically at 14.15mhz. Since the vf of standard 300 ohm ribbon feeder is .82, the mechanical length should be 28ft (8.5m). However, if 300 ohm ribbon with "windows" is used, its vf will be almost that of open-wire feeder, say .90, so its mechanical length should be 30.6ft (9.3m). This section should hang vertically from the centre of the antenna for at least 20ft (6.1m) or more if possible. It can then be bent and tied off to a suitable post with a length of nylon or terylene cord so as to be supported at above head-height to the point where, supported by a second post, its lower end is connected to the feeder.

The Feeder

The antenna can be fed by any convenient type of feeder provided always that a suitable type of antenna tuner is used. In the original article describing the G5RV antenna, published in the , then, RSGB bulletin November 1966, it was suggested that if coaxial cable feeder was used, a balun might be employed to provide the necessary unbalanced-to-balanced transformation at the base of the matching section. This was because the antenna and its matching section constitute a balanced system, whereas a coaxial cable is an unbalanced type of feeder. However, later experiments and a better understanding of the theory of operation of the balun indicated that such a device was unsuitable because of the highly reactive load it would "see" at the base of the matching or "make-up" section on most hf bands.

It is now known that if a balun is connected to a reactive load presenting a vswr of more than about 2:1, its internal losses increase, resulting in heating of the windings and saturation of its core (if used). In extreme cases, with relatively high power operation, the heat generated due to the power dissipated in the device can cause it to burn out. However, the main reason for not employing a balun in the case of the G5RV antenna is that, unlike an antenna tuner which employs a tuned circuit, the balun cannot compensate for the reactive load condition presented to it by the antenna on most of the hf bands, whereas a suitable type of antenna tuner can do this most effectively and efficiently.

Recent experiments by the author to determine the importance or otherwise of "unbalance" effects caused by the direct connection of a coaxial feeder to the base of the matching section had a rather surprising result. They proved that, in fact, the hf currents measured at the junction of the inner conductor or the coaxial cable with one side of the (balanced) matching section and at the junction of the outer coaxial conductor (the shield) with the other side of this section are virtually identical on all bands up to 28mhz, where a slight but inconsequential difference in these currents has been observed. There is, therefore, no need to provide an unbalanced-to-balanced device at this junction when using coaxial feeder.

However, the use of an unbalanced-to-unbalanced type of antenna tuner between the coaxial output of a modern transmitter (or transceiver) and the coaxial feeder is essential because of the reactive condition presented at the station end of this feeder which, on all but the 14mhz band, will have a fairly high to high vswr on it. This vswr, however, will result in insignificant losses on a good-quality coaxial feeder of reasonable length; say, up to about 70ft (21.3m). Because it will, inevitably, have standing waves on it, the actual characteristic impedance of the coaxial cable is unimportant, so that either 50 ohm or 80 ohm type can be used.

Another very convenient type of feeder that may be used is 75 ohm twinlead. However, because of the relatively high loss in this type of feeder at frequencies above about 7mhz, especially when it has a high vswr on it, it is recommended that not more than about 50 to 60ft (15.2 to 18.3m) of this type feeder be used between the base of the matching section and the antenna tuner. Unfortunately the 75 ohm twinlead in the UK is the receiver type; the much less lossy transmitter type is available in the USA. By far the most efficient feeder is the "open wire" type. A suitable length of such feeder can be constructed in exactly the same way as that described for the open-wire matching section. If this form of feeder is employed, almost any convenient length may be used from the centre of the antenna right to the antenna tuner (balanced) output terminals. In this case, of course, the matching section becomes an integral part of the feeder. A particularly convenient length of open-wire feeder is 84ft (25.6m), because such a length permits parallel tuning of the

antenna tuner circuit on all bands from 3.5 to 28mhz with conveniently located coil taps in the antenna tuner coils for each band, or, where the alternative form of antenna tuner employing a three-gang 500pf/section variable coupling capacitor is used the optimum loading condition can be achieved for each band. However, this is not a rigid feeder length requirement and almost any length that is mechanically convenient may be used. Since this type of feeder will always carry a standing wave, its characteristic impedance is unimportant, and sharp bends, if necessary, may be used without detriment to its efficiency. It is only when this type of feeder is correctly terminated by a resistive load equal to its characteristic impedance that such bends must be avoided.

Coaxial cable hf choke

Under certain conditions, either due to the inherent "unbalanced-to-balanced" effect caused by the direct connection of a coaxial feeder to the base of the (balanced) matching section, or to pick-up of energy radiated by the antenna, a current may flow on the outside of the coaxial outer conductor. This effect may be considerably reduced, or eliminated, by winding the coaxial cable feeder into a coil of 8 to 10 turns about 6in in diameter immediately below the point of connection of the coaxial cable to the base of the matching section. the turns may be taped together or secured by nylon cord.

It is important, of course, that the junction of the coaxial cable to the matching section be made thoroughly water-proof by any of the accepted methods; binding with several layers of plastic insulating tape or self-amalgamating tape and then applying two or three coats of polyurethane varnish, or totally enclosing the end of the coaxial cable and the connections to the base of the matching section in a sealant such as epoxy resin.



LOW REACTANCE MULTIBAND CENTER FED WIRES

An antenna system is more easily interfaced to a radio when the input reactance at the feedline terminals is low or close to series resonance. If a center fed dipole is fed with a length of low loss balanced transmission line, the input reactance is a function of both transmission line length and antenna length, and to reduce the reactance at selected frequencies there are optimum lengths of dipole and feedline. The G5RV antenna design is an example of selecting these lengths to produce near-series resonances at amateur operating frequencies from 3.5-28MHz. There are other combinations of feedline length and dipole length which reduce the overall reactance as shown below. The red regions of Figure 1 have low RMS reactance over the frequencies shown to the right of the figure.

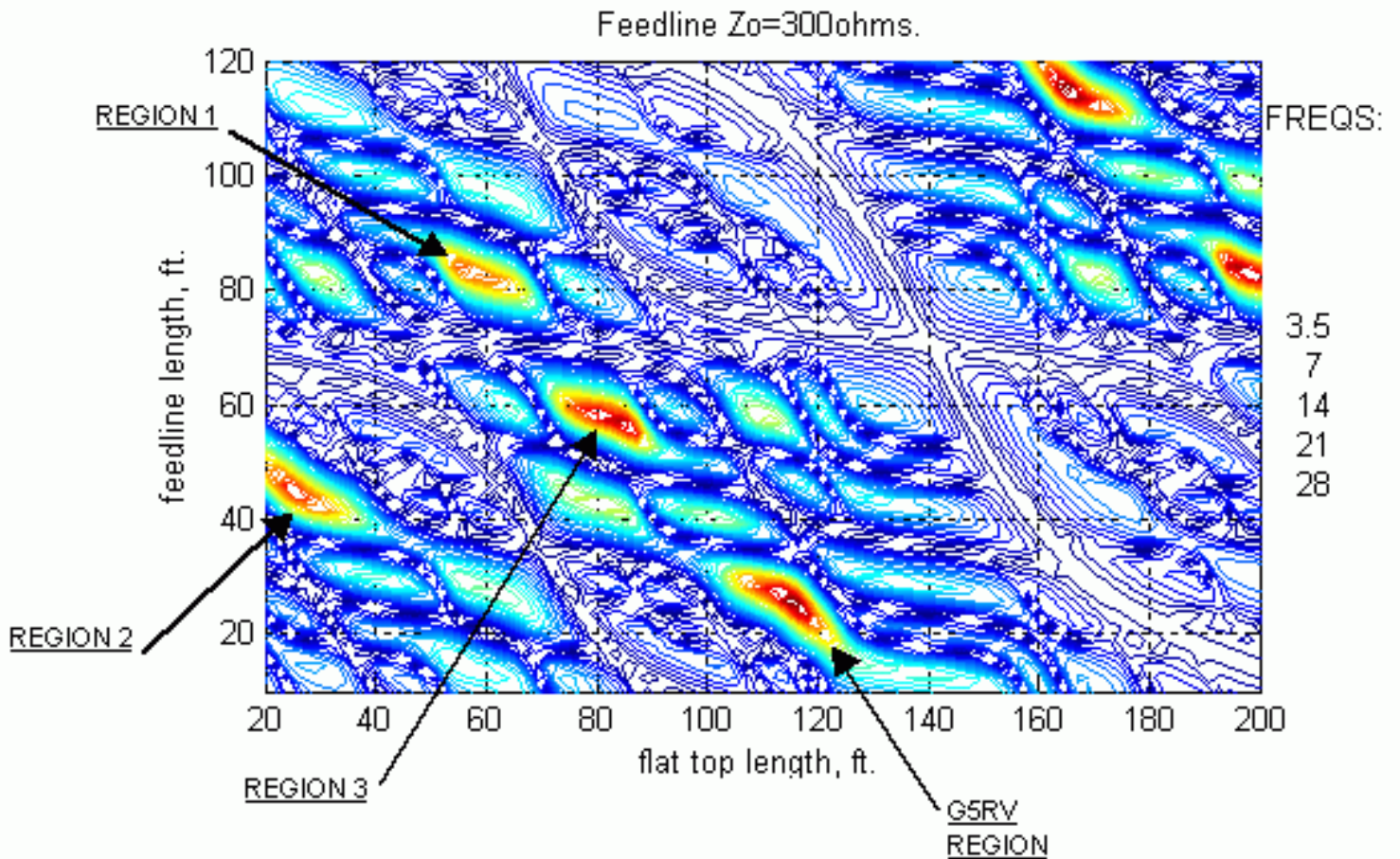

Figure 1. Regions of Low RMS Input Reactance at Amateur Bands.

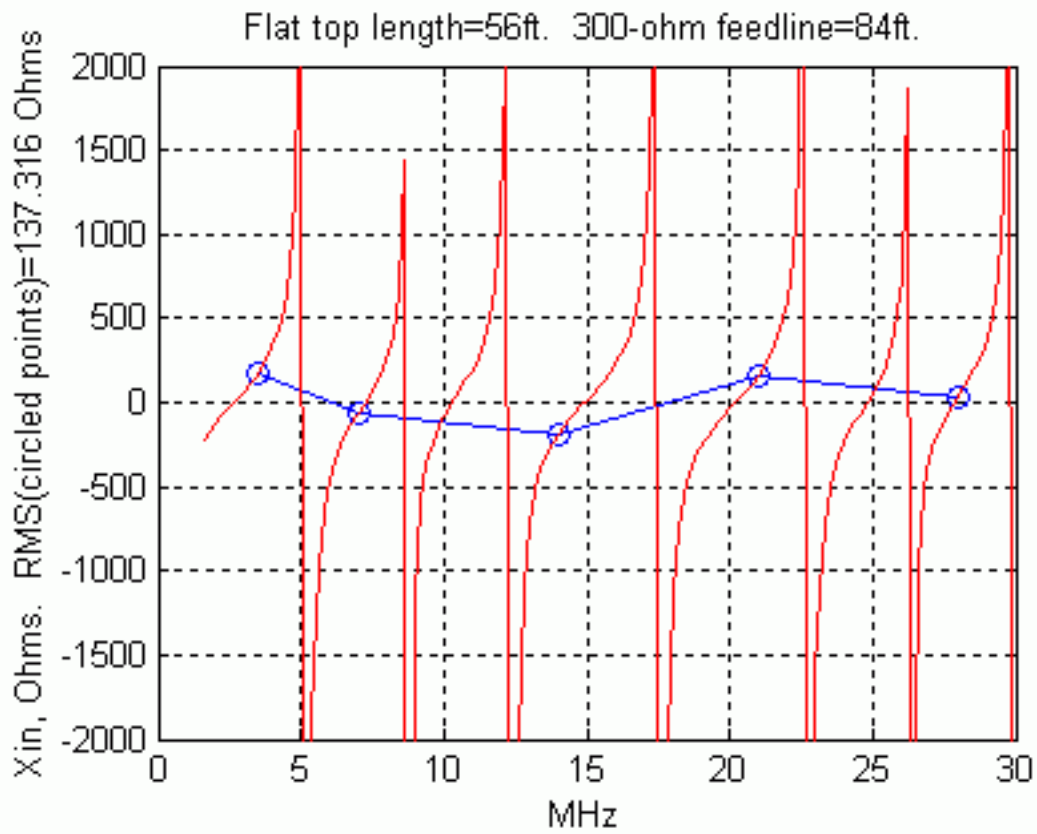
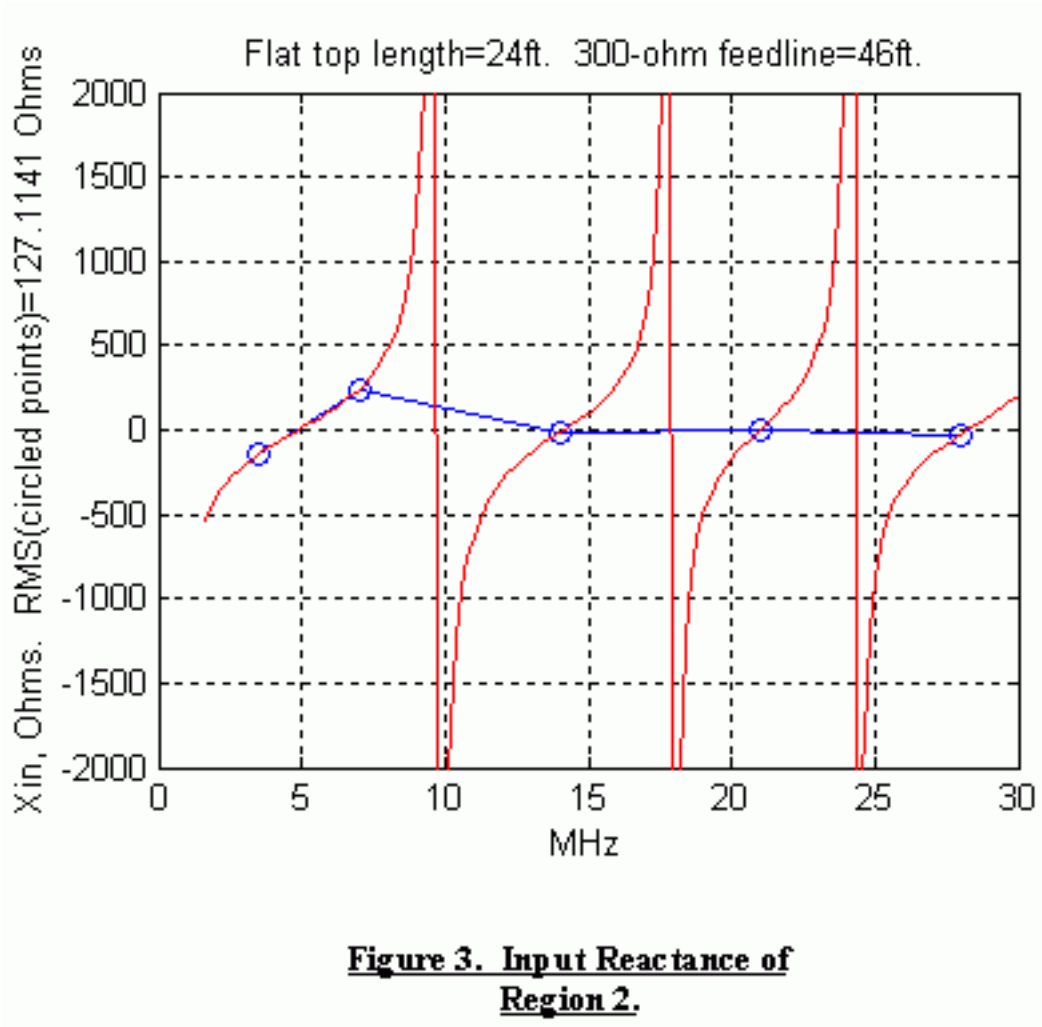

Figure 2. Input Reactance of Region 1.



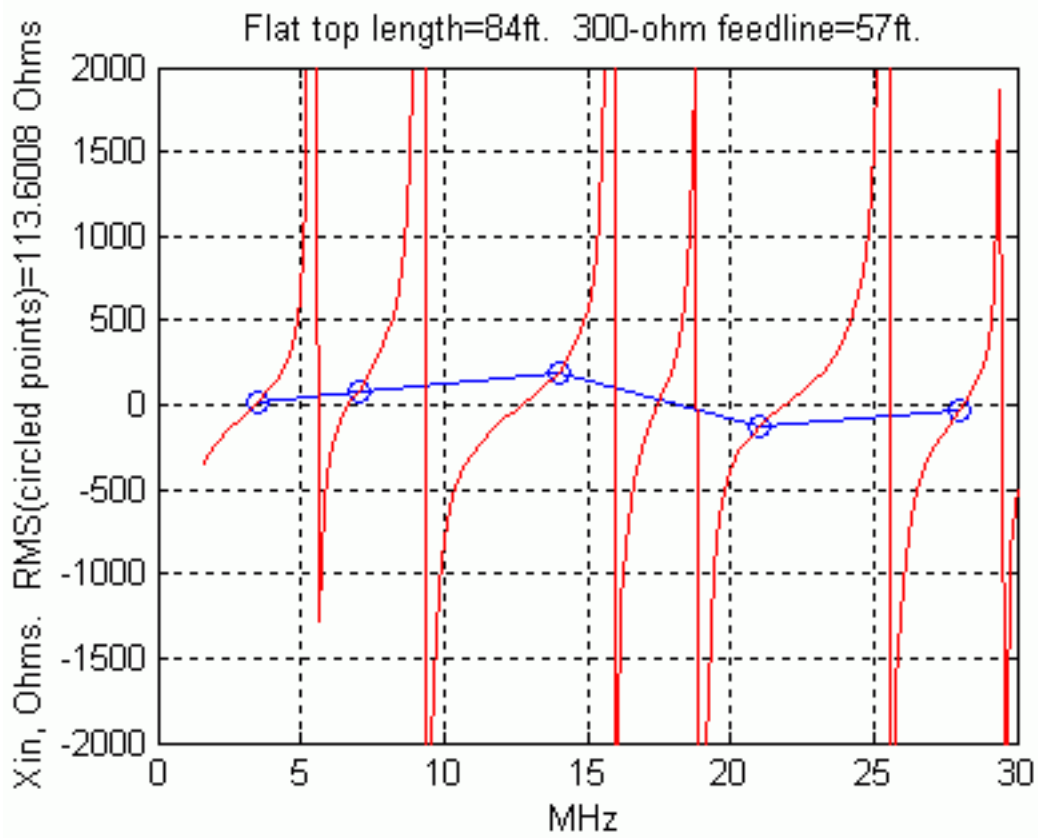

Figure 4. Input Reactance of Region 3.

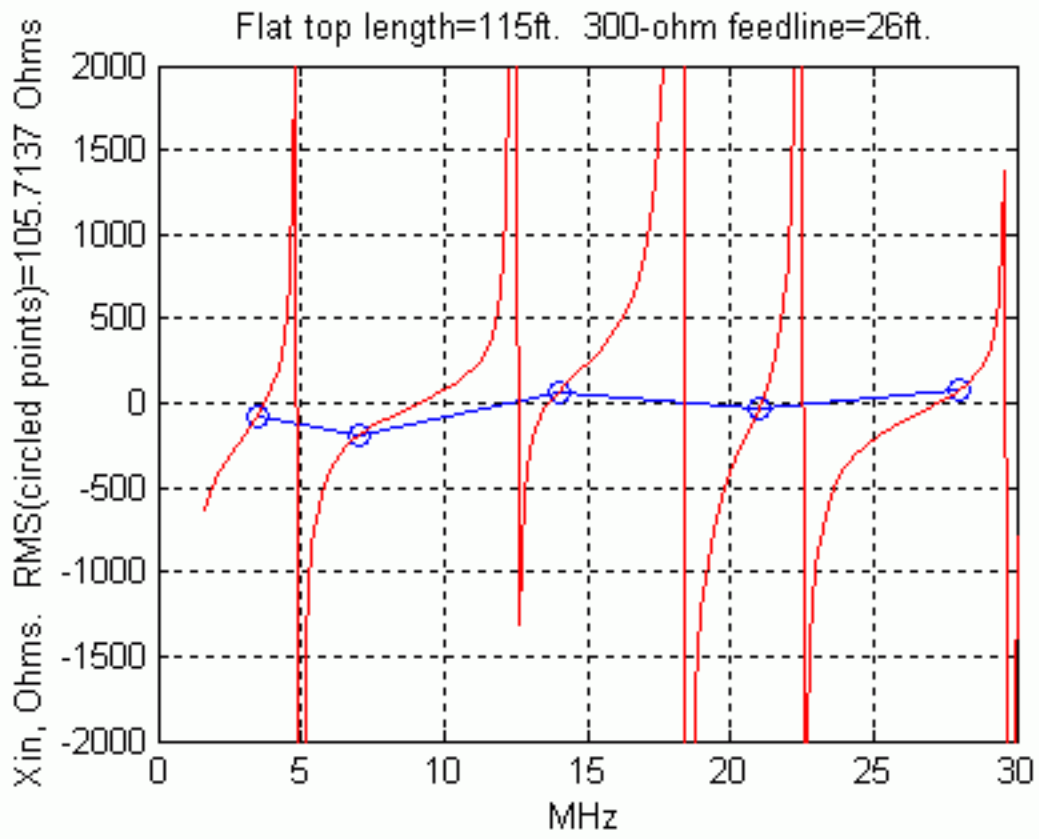

Figure 5. Input Reactance in G5RV Region.

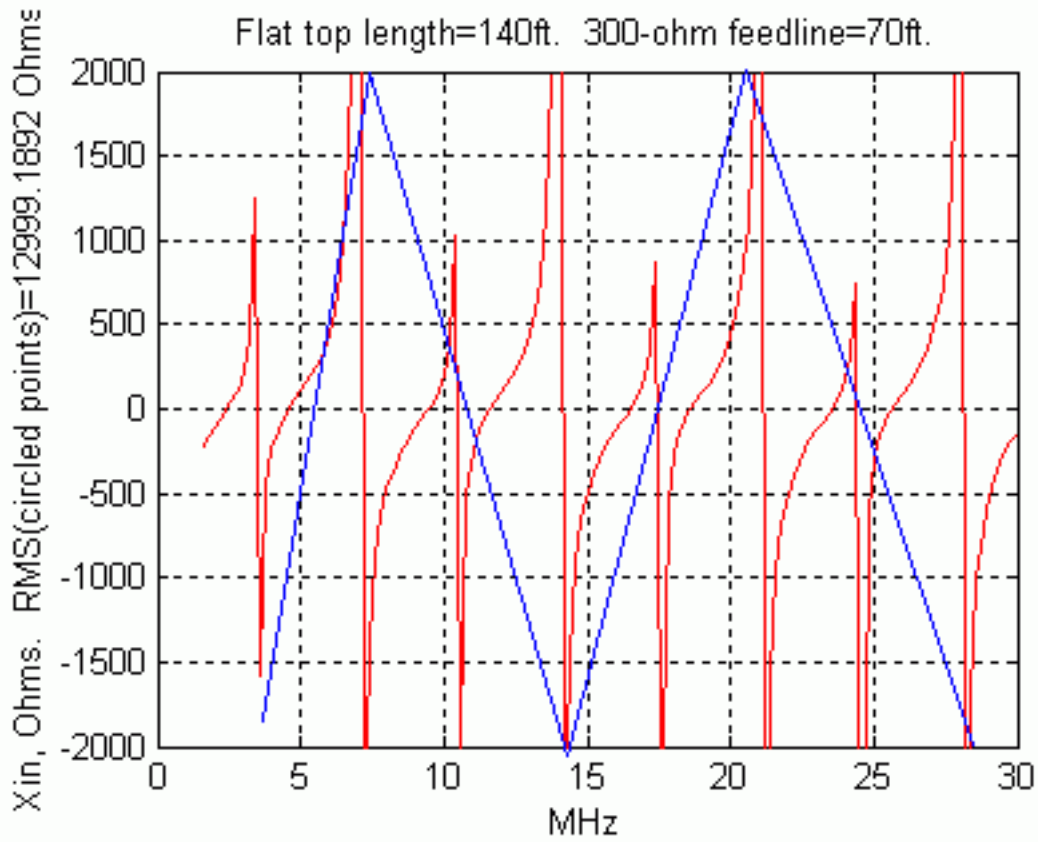

Figure 6. A Bad Choice of Lengths.

Grounding is key to good reception

From: jpd@space.mit.edu (John Doty)

Newsgroups: rec.radio.shortwave

Subject: Grounding is key to good reception, was: Experience w/NRD-535

Date: 16 Feb 1995 16:36:40 GMT

In article <825_9502140342@tor250.org> Larry.Picard@odxabbs.tor250.org (Larry Picard) writes:

In your recent post you advised that coax should be grounded at two sites, first at the antenna and then just before entering the house. Is there an advantage in grounding at more than these sites?

With grounds the most common experience is "the more the merrier". As you add more, however, you usually reach a diminishing returns (no pun intended) situation where there is no *observable* improvement: that's usually a good place to stop. There are also exceptional circumstances where grounding increases noise problems, but these, in my experience, are much rarer than the pundits who preach against "ground loops" seem to think.

Even a semi-quantitative theoretical treatment of grounding in oversimplified situations requires heavy math at RF. Experimentation is thus required even if one has done elaborate calculations. It's often easier to use the theory as a guide to what to try, and then experiment.

I would also assume that the antenna is grounded when it is connected to the receiver as the outer braid of the coax is in continuity with the receiver chassis.

What's ground? If connect the shield of my coax (which is grounded outside) to the antenna input of my R8, I hear lots of junk, indicating that there is an RF voltage difference between the coax shield and the R8 chassis. Last night this measured about S5.5, which is about -93 dBm (preamp off, 6KHz bandwidth). That's a lot of noise: it was 18 dB above my antenna's "noise floor", and 26 dB above the receiver's noise floor.

This sort of disagreement about ground potential is characteristic of electrically noisy environments. The receiver will, of course, respond to any voltage input that differs from its chassis ground. The antenna, on the other hand, is in a very different environment, and will have its own idea of what ground potential is. If you want to avoid noise pickup, you need to deliver a signal, referenced at the antenna to whatever its ground potential is, in such a way that when it arrives at the receiver, the reference potential is now the

receiver's chassis potential.

Coaxial cable represents one way to do this. Coax has two key properties:

1. The voltage between the inner conductor and the shield depends only on the state of the electromagnetic field within the shield.
2. The shield prevents the external electromagnetic field from influencing the internal electromagnetic field (but watch out at the ends of the cable!).

So, it's easy, right? Run coax from the antenna to the receiver. Ground at the antenna end will be whatever the antenna thinks it is, while ground at the receiver end will be whatever the receiver thinks it is. The antenna will produce the appropriate voltage difference at the input side, and the receiver will see that voltage difference uncontaminated by external fields, according to the properties given above.

Unfortunately, it doesn't quite work that way. It's all true as far as it goes, but it neglects the fact that the coax can also guide noise from your house to your antenna, where it can couple back into the cable and into your receiver. To see how this works, let me first describe how this noise gets around.

The noise I'm talking about here is more properly called "broadband electromagnetic interference" (EMI). It's made by computers, lamp dimmers, televisions, motors and other modern gadgets. I have all these things. In many cases, I can't get them turned off, because it would provoke intrafamilial rebellion. However, even when I turn them off, the noise in the house doesn't go down very much, because my neighbors all have them too. In any case, one of the worst offenders is my computer, which is such a handy radio companion I'm not about to turn *it* off.

Some of this noise is radiated, but the more troublesome component of this is conducted noise that follows utility wires. Any sort of cable supports a "common mode" of electromagnetic energy transport in which all of the conductors in the cable are at the same potential, but that potential differs from the potential of other nearby conductors ("ground"). The noise sources of concern generate common mode waves on power, telephone, and CATV cables which then distribute these waves around your neighborhood. They also generate "differential" mode waves, but simple filters can block these so they aren't normally a problem.

So, let's say you have a longwire antenna attached to a coaxial cable through an MLB ("Magnetic Longwire Balun" [sic]). Suppose your next door neighbor turns on a dimmer switch. The resulting RF interference travels out his power lines, in through yours, through your receiver's power cord to its chassis, and out your coaxial cable to your MLB. Now on coax, a common mode wave is associated with a current on the shield only, while the mode we want the signal to be in, the "differential" mode, has equal but opposite currents flowing on shield and inner conductor. The MLB works by coupling energy from a current flowing between the antenna wire and the coax shield into the differential mode. But wait a second: the current from the antenna flows on the coax shield just like the common mode current

does. Does this mean that the antenna mode is contaminated with the noise from your neighbor's dimmer?

The answer is a resounding (and unpleasant) yes! The way wire receiving antennas work is by first moving energy from free space into a common mode moving along the antenna wire, and then picking some of that off and coupling it into a mode on the feedline. In this case, the common mode current moving along the antenna wire flows into the common mode of the coax, and vice versa. The coax is not just feedline: it's an intimate part of the antenna! Furthermore, as we've seen, it's connected back through your electrical wiring to your neighbor's dimmer switch. You have a circuitous but electrically direct connection to this infernal noise source. No wonder it's such a nuisance!

The solution is to somehow isolate the antenna from the common mode currents on the feedline. One common way to do this is with a balanced "dipole" antenna. Instead of connecting the feedline to the wire at the end, connect it to the middle. Now the antenna current can flow from one side of the antenna to the other, without having to involve the coax shield. Unfortunately, removing the necessity of having the coax be part of the antenna doesn't automatically isolate it: a coax-fed dipole is often only slightly quieter than an end-fed longwire. A "balun", a device which blocks common mode currents from the feedline, is often employed. This can improve the situation considerably. Note that this is not the same device as the misnamed "Magnetic Longwire Balun".

Another way is to ground the coaxial shield, "short circuiting" the common mode. Antenna currents flow into such a ground freely, in principle not interacting with noise currents. The best ground for such a purpose will be a earth ground near the antenna and far from utility lines.

Still another way is to block common mode waves by burying the cable. Soil is a very effective absorber of RF energy at close range.

Unfortunately, none of these methods is generally adequate by itself in the toughest cases. Baluns are not perfectly effective at blocking common mode currents. Even the best balun can be partially defeated if there's any other unsymmetrical coupling between the antenna and feedline. Such coupling can occur if the feedline doesn't come away from the antenna at a right angle. Grounds are not perfect either. Cable burial generally lets some energy leak through. A combination of methods is usually required, both encouraging the common mode currents to take harmless paths (grounding) and blocking them from the harmful paths (baluns and/or burial).

The required isolation to reach the true reception potential of the site can be large. According to the measurements I quoted above, for my site the antenna noise floor is 18 dB below the conducted noise level at 10 MHz. 18 dB of isolation would thus make the levels equal, but we want to do better than that: we want the pickup of common mode EMI to be insignificant, at least 5 dB down from the antenna's floor. In my location the situation gets worse at higher frequencies as the natural noise level drops and therefore I become more sensitive: even 30 dB of isolation isn't enough to completely silence the common mode noise (but 36 dB **is** enough, except at my computer's CPU clock frequency of 25 MHz).

Getting rid of the conducted noise can make a huge difference in the number and kinds of stations you can pick up: the 18 dB difference between the conducted and natural noise levels in the case above corresponds to the power difference between a 300 kW major world broadcaster and a modest 5 kW regional station.

The method I use is to ground the cable shield at two ground stakes and bury the cable in between. The scheme of alternating blocking methods with grounds will generally be the most effective. The ground stake near the house provides a place for the common mode noise current to go, far from the antenna where it cannot couple significantly. The ground stake at the base of my inverted-L antenna provides a place for the antenna current to flow, at a true ground potential relative to the antenna potential. The buried coax between these two points blocks noise currents.

There has been some discussion of grounding problems on this and related echos. I believe it has been mentioned that electrical codes require that all grounds be tied together with heavy guage wire.

I'm no expert on electrical codes, and codes differ in different countries. However, I believe that any such requirement must refer only to grounds used for safety in an electric power distribution system: I do not believe this applies to RF grounds.

Remember that proper grounding practice for electrical wiring has very little to do with RF grounding. The purpose of an electrical ground is to be at a safe potential (a few volts) relative to non-electrical grounded objects like plumbing. At an operating frequency of 50/60 Hz, it needs to have a low enough impedance (a fraction of an ohm) that in case of a short circuit a fuse or breaker will blow immediately.

At RF such low impedances are essentially impossible: even a few centimeters of thick wire is likely to exhibit an inductive impedance in the ohm range at 10 MHz (depends sensitively on the locations and connections of nearby conductors). Actual ground connections to real soil may exhibit resistive impedances in the tens of ohms. Despite this, a quiet RF ground needs to be within a fraction of a microvolt of the potential of the surrounding soil. This is difficult, and that's why a single ground is often not enough.

A little experimentation with my radio showed that the chassis was directly connected to the third (grounding) prong of the wall plug. I am concerned that by connecting my receiver to an outside ground I am creating a ground loop that involves my house wiring. Can you comment on this?

Yes, you have a "ground loop". It's harmless. In case of a nearby lightning strike it may actually save your receiver. My R8 isn't grounded like that, so I had to take steps to prevent the coax ground potential from getting wildly out of kilter with the line potential and arcing through the power supply. I'm using a surge suppressor designed to protect video equipment: it has both AC outlets and feedthroughs with varistor or gas tube clamps to keep the various relative voltages in check. Of course the best lightning protection is to disconnect the receiver, but I'm a bit absent minded so I need a backup.

This may seem like a trivial point but I recently discovered that the main ground from the electrical service panel in my house was attached to a water pipe which had been painted over. I stripped the paint from the pipe and re-attached the grounding clamp and I noticed a reduction in noise from my receiver.

Not trivial. Not only did you improve reception, but your wiring is safer for having a good ground.

I suspect part of the reason I see so much noise from neighbors' appliances on my electric lines may be that my house's main ground wire is quite long. The electrical service comes in at the south corner of the house (which is where the breaker box is), while the water (to which the ground wire is clamped) enters at the east corner. All perfectly up to code and okay at 60 Hz, but lousy at RF: if it was shorter, presumably more of the noise current would want to go that way, and stay away from my receiver.

I am also a little confused by what constitutes an adequate ground. I have read that a conducting stake driven into the ground will divert lightning and provides for electrical safety but that RF grounding systems have to be a lot more complex with multiple radials with lengths related to the frequencies of interest. Is this true?

Depends on what you're doing. If you're trying to get maximum signal transfer with a short loaded (resonant) vertical antenna with a radiation resistance of, say, 10 ohms, 20 ohms of ground resistance is going to be a big deal. If you're transmitting 50 kW, your ground resistance had better be *really* tiny or things are going to smoke, melt or arc.

On the other hand, a ground with a resistance of 20 ohms is going to be fairly effective at grounding a cable with a common mode characteristic impedance of a few hundred ohms (the characteristic impedance printed on the cable is for the differential mode; the common mode characteristic impedance depends somewhat on the distance of the cable from other conductors, but is usually in the range of hundreds of ohms). Of course, if it was lower a single ground might do the whole job (but watch out for mutual inductance coupling separate conductors as they approach your single ground).

In addition, a ground with a resistance of 20 ohms is fine for an unbalanced antenna fed with a high

impedance transformer to suppress resonance. Such a nonresonant antenna isn't particularly efficient, but high efficiency is not required for good reception at HF and below (not true for VHF and especially microwave frequencies).

Much antenna lore comes from folks with transmitters who, armed with the "reciprocity" principle, assume that reception is the same problem. The reciprocity principle says that an antenna's transmission and reception properties are closely related: it's good physics, but it ignores the fact that the virtues required of a transmitting and receiving antenna are somewhat different. Inefficiency in a transmitting antenna has a direct, proportional effect on the received signal to noise ratio. On the other hand, moderate inefficiency in an HF receiving antenna usually has a negligible effect on the final result. A few picowatts of excess noise on a transmitting antenna has no effect on its function, but is a big deal if you're receiving (of course, one might not want to have transmitter power going out via unintended paths like utility lines: this is indeed the "reciprocal" of the conducted noise problem, and has similar solutions).

Appendix: Absolute RF measurements with an R8.

Although the Drake R8's signal strength meter is marked with silly "S" units, the alignment procedure in the service manual actually sets up the meter to an absolute standard, at least sort of. A 60% modulated signal with a carrier level of -73 dBm (which is really closer to -72 dBm in total power including sidebands) is S9. One S unit is 5 dB. This is with 6 kHz bandwidth and with neither the RF preamp or attenuator engaged. I assume this is what they do at the factory.

Now, I don't really know how accurately this calibration is performed, and it certainly can't be more accurate than the flatness of the input passband filters (spec'd at <2 dB p-p). There are also problems because the measurement is actually being made by a peak-responding AGC system rather than an RMS meter. Based on experience with other peak sensing systems, I estimate that the meter probably reads noise power too high by about 3 dB, relative to the carrier power in the test waveform. Therefore, for noise, S9 is about -76 dBm.

On my R8, the linearity of the S-meter calibration is poor at the very low end: S1 is much less than 10 dB below S3. Therefore, for measurements below S3 I do relative measurements and refer them to stronger signals. I have on my NeXT computer an old demo application that gives the RMS amplitude of a signal on the audio input jack. With the R8's AGC turned off and the RF gain set low enough to insure good linearity, this may be used to make quite accurate relative power measurements. You could, of course, use an ordinary AC voltmeter to do this if you have one sensitive enough to read the level of the Drake's audio output (I don't have one).

Considering all of the uncertainties, the numbers hold together remarkably well, better than the likely accuracies in this case (just dumb luck).

For the measurements quoted in my previous message, the receiver's noise floor is -119 dBm. Drake's specs imply that for a 6 kHz bandwidth the noise floor should be below -118 dBm with the preamp off.

According to "Reference Data for Radio Engineers" (Sams, 1975), the wintertime level of natural noise in my area at 10 MHz should be about 32 dB above the thermal reference level: this would produce a noise floor of -104 dBm in this bandwidth with a perfectly efficient antenna. A calculation for a 17 m vertical antenna feeding a high impedance transformer predicts a loss due to mismatch/lack of resonance of 4.5 dB at 10 MHz. My antenna is not a vertical but an inverted L which I presume is slightly less efficient (difficult to calculate). There are also presumably some modest losses in the transformer, the grounds, the cables and the connectors. I wouldn't be surprised if these added up to 3 dB or so. With a total antenna system inefficiency of 7 dB, I'd therefore expect to see an antenna noise floor of -111 dBm, which is, in fact, just what I measure.

[\[Previous\]](#) | [\[BADX home page\]](#) | [\[Next\]](#)

Last modified: *March 10, 1998*

E-mail your comments and updates to [Steve Byan](mailto:smb@world.std.com) <smb@world.std.com>

The Tech Bench Elmers

Amateur Radio Society

Club Station Callsign
KF6GDJ

*Our Web Page is located at: <http://www.geocities.com/SiliconValley/2775/>
P.O. Box 1112 Sierra Madre, CA 91025 or e-mail: techbench@geocities.com*

[Home](#) | [Site Map](#) | [Calendar](#) | [e-mail](#) | [Links](#) | [Meetings](#)

Grounding Systems for Amateur Radio Stations

By: [John Wendt WA6BFH](#)

There is quite a bit of talk these days between Amateur (**Ham**) Radio operators about the desirability for "**good grounding systems**" for their home radio stations. I can tell you honestly that this was not so fervently discussed on the radio in earlier decades. My suspicion for this is that there was a better understanding in earlier times, before the advent of our rapid increase in new operators, of the conditions under which a "**grounding system**" would do some good. Lets look at this carefully and critically so that we can assess the desirability of a grounding system for our radio stations.

Safety Grounds vs. Radio Frequency (RF) Grounds

First of all realize that there are two discreet types of ground systems and reasons why a Ham might desire to provide a "**station ground**". These are for the most part mutually exclusive! In other words one does one job for which it is specifically designed, and one does a different job. You must design your grounding system with this in mind, or one function may inhibit or nullify the other!

One of these grounding systems is what I will generally describe as a "**safety ground**". This safety ground is installed to reduce the risk of electrocution or radio equipment damage by short circuited "**power mains**", or from lightening strikes to the antenna or "**feedline**" system. A safety grounding system is certainly a good Ham Radio "**engineering practice**", although it is usually considered as of secondary importance to an "**RF ground**"! In portions of our country where dramatic lightening storms are common this preference is probably reversed. I can tell you that even in the portion of Southern California that I live in, lightening strikes from annual spring storms, or even the thought of accidental "**short circuit**" electrocution are enough of a concern that I have a safety ground system for my station. I have designed it though to operate in conjunction with the RF grounding system I use! Lets talk about the considerations of properly designing an RF grounding system. Through the course of this discussion I

will explain how an RF ground can be utilized as a safety ground, and also that a safety ground **should never** be used as an RF ground!

The RF or Radio Frequency Grounding System

A popular misconception is that all radio antenna systems should be grounded to enhance their radio performance. If grounding these antennas was for the purpose of safety, as I have clarified in the earlier paragraphs, this might be true. To think though that grounding an antenna will automatically make it a better communications device is completely wrong! To appreciate this we must think in terms of "**radio frequency wavelength**", or fractions of wavelength at 1/4 wavelength increments.

On certain lower frequency longer wavelength bands an RF ground is not only a reasonable consideration but, it is fundamental to getting the best communications performance from your radio station. At other higher frequency and shorter "**wavelength bands**" however, RF grounds are either superfluous, or even harmful to overall communications performance! Lets look at this carefully as illustrated in typical and practical scenarios. Keep in mind the concept of thinking about the physical length of the "**grounding conductor**" in relationship to its comparative "**wavelength dimension**"!

The Practical Station Ground

Living in a typical single story ranch style home my choices and availability for a good RF ground installation are relatively simple. The first "**ground rod**" of my grounding system is within 4 feet 2 inches or 1.27 meters of my station equipment. This 50 inch dimension is the entire or total length of the conductor to this first grounding rod. From this first 10 foot deep ground rod, a # 6 AWG. (American Wire Gauge) bare copper wire is buried and runs under ground in a one foot deep trench to a second 10 foot long rod about 15 feet distant. This second rod is then connected to a very elaborately designed grounding system at the base of my antenna tower's foundation. The length of this conductor between the second ground rod and the tower base is 16 feet. The entirety of these ground rods, and the interconnecting conductors, are buried at about 12 inches deep. Take a look at Figure 1 to see this system drawn to scale.

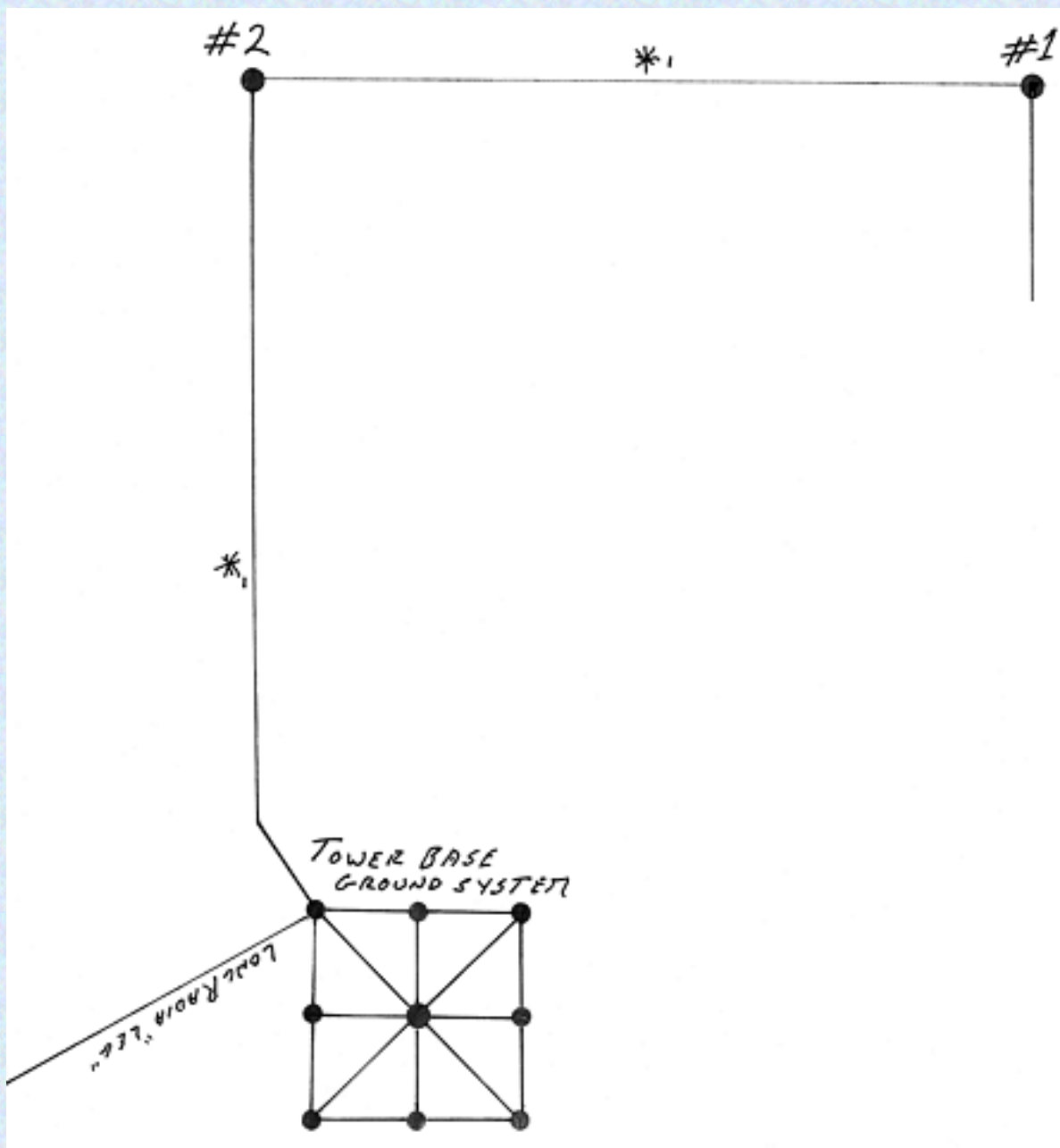

Figure 1.

When you look over this drawing you might think, gee if he says its important to keep the ground conductor as short as possible, why does he have almost 5 meters (15.5 feet) of separation between ground rods. He could have even run a wire from ground rod number 1, straight to the tower base! Well believe me, if I could have, I would have! The combined 15 and 16 foot dimensions surround the perimeter of a building, so that I was forced to take this longer circuitous route! This really though isn't such a bad happenstance!

Having the ground rods this far apart is actually a desirable feature. What is being achieved by this system is to make a "**large surface contact area**" to earth ground. It also functions to reduce "**ground loops**" as well as is possible. Even though I can't prevent all ground loop conditions, I can keep them manageable! I had thought that in my original design that I might also place 10 foot deep rods at the points where asterisks are shown. After testing the system on the MF (Medium Frequency) and HF (High

Frequency) wave-length bands, I found these additional rods to be unnecessary.

Ground Loops (and the worst case scenario)

Ground loops are the major concern and worry to be dealt with as you lay out an RF ground system! Lets lay out a worst possible case scenario of what would be a terrible way to ground a 20 meter (and all harmonically related bands) home station.

Lets say that our 20 meter Ham has his "Ham Shack" in approximately the middle of his house, up on the second story of the house. He uses a nice low resistance and low inductance flat braided strap (lets let him do at least one thing right), which runs from his 1500 Watt amplifier to a 2 foot deep ground rod in his front yard. This braided conductor runs between the floor of the second story and the ceiling of the lower story. It then runs down the outside of his stucco covered home to the ground rod. Its total length is 33 feet long from the amplifier to the ground rod.

Fifty feet (15.24 meters) of coaxial cable goes up between the walls of the second story, is draped over to the top of his tower, and terminates at his TH6DXX beam on this 65 foot tall tower. Lets break down these dimensions in terms of wavelength, and even look at them as they may appear to form a "**current loop**"!

Our rueful Ham friend is using a ground conductor that is almost exactly one half wavelength long and is raised in the air by the buildings structure. Even if this length were reduced to about a quarter wavelength, it would still very nicely couple energy into other wiring in the house, and also the wire mesh beneath the stucco walls. This other wiring could be telephone wires, television cabling, and the 110 volt power wiring in the house. His coax cables shield is a nice "**odd order harmonic**" radiator, as it is 3/4 wavelength long! The ungrounded tower is about a half wavelength tall.

This last point about the tower must be viewed carefully. He might want to ground it as an RF consideration, and he might not! Think about it this way. One ground rod is in the front yard at the end of a half wavelength wire. The shield of the coax cable ultimately goes to ground in the back yard at the tower base at an electrical length of about 7 quarter wavelengths ($50 + 65 = 115$ feet). This makes another sort of odd order harmonic radiator! If you add into this loop circuit the length of the front yard ground rod conductor, the loop circumference becomes 9 quarter wavelengths. Yet another odd order radiator dimension!

My assessment of this Ham's station would inform me that he is throwing away some of the advantage of his beam and the height of his tower because, all of the radiating conductors strung around the house raise the "**angle of radiation**" considerably higher than it could otherwise be! He is also enhancing the prospects of "**audio rectification**" to his own and to neighbors telephones. He is also enhancing the possibility of "**TVI**" to his television, and maybe to the neighbors as well if they all use a cable TV system.

The Absolute Worst Thing To Do

Maybe though this isn't the worst case scenario? The worst case would be the Ham that tries to use the 3rd wire ground within the 110 volt AC power system that runs though out his house. Then he could really couple RF energy around his house and the neighborhood! **Never ever use this 3rd. wire ground as an RF ground!**

How Should our Ham have done it

- 1) His station should be on the ground floor of the house.
- 2) His low inductance low resistance grounding conductor should have considerably less than a quarter wavelength of total length between his amplifier and the first ground rod.
- 3) If the soil or other conditions in his yard allowed only short length rods, he should have used several of them all tied in a line, and ultimately connected to a "**grounding cage**" or rods near the **outside** of the tower's concrete base.

Important Tip: Don't install the ground cage within the concrete! One reason is that it is connected to the earth via the high resistance of the concrete. The other reason is that a lightening strike to the tower may well blow the concrete block to bits!

When Should an RF Ground Be Used and When is it a Bad Thing

With the advent of the many new MF/HF/VHF transceivers on the market these days, Hams are flocking to frequency bands on which they have little or no experience. Additionally because of the licensing structure, one of the most popular Ham bands in use is the 10 Meter band. I'm sure also that within the coming years, 6 Meters will become even more popular. On 6 meters at least, RFI is very simply controlled.

On one of these two mentioned bands, and also on most bands above 20 Meters, television interference from harmonic radiation becomes a concern that grounding will not fix. In fact most practical possibilities for grounding systems at a typical residential home, will enhance this TVI (Television Interference) problem!

Think about it this way, the 2nd. Harmonic of the 28 MHz. band falls right at TV channel 2 ($2 \times 28 = 56$ MHz.)! This is the fourth harmonic of the 20 Meter band ($4 \times 14 = 56$ MHz.)! From this description and the other worst case scenarios that I outlined, you may be thinking, so is he saying not to bother with installing a ground system? Well, that's not at all what I'm saying! I am telling you though that you must appreciate and design your grounding system so that it cannot possibly contribute to either "**fundamental frequency**" radiation, and also not contribute to the re-radiation of harmonics of these upper HF bands.

The prime methods for accomplishing this are to (1) keep the ground conductor shorter than a quarter wavelength on 10 Meters, which is of course the highest frequency HF band. Next we must, (2) make this conductor be at the lowest AC resistance (impedance) possible! We do this by using large surface area (fat) conductors, and **SOLDER** all connections. After soldering, seal them from the eroding effects of weather by using electricians tape and silicon sealers. Anti-oxidizing compounds such as "No-Ox", which are available at most electrical suppliers, are a must for any connection of dissimilar metals! A simpler way to deal with this last mentioned concern is to simply use non-alloy baring copper for the entire system. Copper tubing typically used for plumbing meets all of the above requirement perfectly. Don't use steel or iron pipe for ground rods! Always (3) connect multiple ground rods in a line. This line can bend or zigzag but, it must extend from the nearest to the furthest ground rod or screen in a line. The last physical consideration (4) is to cover as much ground surface area as is practical within the constraints of your yard or acreage. A minimum RF ground system will use at least three 8 foot or longer ground rods. If you can't sink a rod that long, than you must use many more shorter rods, or bury a splayed out radial system of wires. In this last case you must terminate this wire radial screen within less than a quarter wavelength at 29.7 MHz. (which is 94.5 inches or 2.4 meters).

Thinking conversely, if a grounding system becomes a touchy prospect at the higher bands, might it be a better consideration and benefit at the lower bands such as 160 meters? If you answered this question absolutely, you win a gold star, and Ham of the year award!

On lower frequency bands, both RF noise level, and also "**ground wave**" signal propagation become an important concern. Just to give you a clue, AM broadcast stations invest huge amounts of money in designing and installing their antenna grounding systems. Of course, we are nearby neighbors, almost kissing cousins you might say of the Broadcast band that ends just below 160 meters! On this band doing everything you can to enhance the signal is preeminent within the stations design. It even becomes easier to install a good grounding system than it is to install good antennas!

Think about it. Even if you could put an antenna that is 260 feet long, 100 feet above the ground, it would still be only .19 wavelengths above the ground. That would be the equivalent of installing a 2 meter antenna at about 15.6 inches above the ground! My 160 meter "**Zep**" is 48 feet up at its highest point, this equates to .18 wavelengths. This actually places the "**high current point**", which is main working point of the antenna, at 37 feet. Thirty-seven feet is about .14 wavelengths above the ground at 1.8 MHz. Pretty low, little more than 1/10th of a wavelength! By contrast, a good ground system is easy! Good RF ground systems really come into their own, as far as showing worthwhile value, on the bands below 30 meters!

Lets wrap up these concepts

An RF ground can be used as a safety ground but, a safety ground is often the worst sort of RF ground.

Multiple ground rods provide the most earth area covered, and consequently, the best sort of grounding

system.

If soil is so rocky that even hydrologically installed ground rod tubes aren't possible, a screen or web of wires below the ground surface will work well. Always use metalurgically sound, true copper wire. No alloys! Cover the largest surface area possible.

Tip: These wires can be installed in a radial fashion, by making slits in the earth or lawn with a sidewalk gardening edger. You then stuff bare copper wire in the slits. In this sort of installation wire size can be reduced to save cost. Use large enough wire to provide good physical strength, lets say #16 AWG.. Be certain that it is "**soft copper**". A good test is to heat the wire with a gas flame, a propane cigarette lighter works great. If the wire is truly soft copper non-alloy wire, it will quickly turn green, then black, and loose all of its tensile strength. Another test would be to bury a piece of this wire for a week or more. When you dig it up, if it shows signs of oxidation or pitting, its not pure copper!

A ground cage surrounding a tower foundation provides a good final terminus point for the grounding system. It also provides for the prospect of "**shunt feeding**" the tower as a multi-band vertical antenna.

Why use a Ground Cage

For the Ham that is dedicated enough to our avocation to want the best engineered station possible, an antenna tower of considerable height is a must! The best radios in the world will not out perform poorer radios using an efficient antenna!

If you are going to install a tall tower (at least a half wavelength tall in the center of the HF spectrum) your going to have to dig a deep hole for the towers concrete base. The kind of tower I'm speaking of as a minimum will require at least a 6 foot deep hole that is 3 feet per side. I think its advisable though to install a foundation for a larger tower. You never know, you may someday want a nice 90 or 120 foot tall tower. This sort of tower requires at least a 9 foot deep hole that is 4 or 5 feet square. After such a hole has been dug, putting in a ground cage is simple!

First install the longest feasible ground rod in the center of this hole. Hopefully this rod will be at least 8 feet long. Even if you can't install a rod this long into the center bottom of the hole, a shorter rod still adds its length to the wire cage that will reside in the hole.

The cage itself is fabricated from #8 AWG. copper wire. You may visualize this cage as 8 lengths of wire that extend upward from the central ground rod, and reside at each corner of the hole, and the four sides of the hole. It is best to keep the wire contiguous however. If you were to section it into individual lengths, its net resistance (or AC impedance) would be higher than if it is kept as a continuous length. I hope that my verbal description will reveal an assembly that extends 17 feet into the ground (assuming a 9 foot deep foundation hole, and 8 foot rod) and covers a large surface area around the sides of the hole.

After this wire assembly is in place, install the towers steel work base frame. Next before filling the hole

with concrete, install plastic sheeting over the wire. Now when the hole is filled with concrete, the plastic sheeting will insure that the wire is pressed against the dirt sides of the hole, and not encased by concrete. Two ends of the wire can be left to extend above the top of the hole. These will later be attached to the bottom of the tower.

The rod at the bottom center of the hole also provides a solid anchor, to keep the steel work from "floating" or moving about while the concrete is being poured. To accomplish this use Nylon rope and turnbuckles to tension down the steel frame. Nylon rope is used so that no metal work encased within the concrete is electrically connected to the ground system. High voltage static or lightening will now flow only to dirt earth surrounding the concrete. Raise the steel frame above the dirt bottom of the hole with cement foundation pillar blocks. If the ends of the steel frame contact the dirt at any point, they will eventually rust and totally disintegrate!

Let's review the best things to do

1) Always use the shortest and largest surface area conductor feasible. This can be wide metal strap material, or large diameter wire or tubing.

Helpful Tip: I use 1/2 inch diameter copper tubing as my ground conductor between rod #1 and the radios. The "**ground bus**" at the back of the radio bench is yet another piece of tubing, with short braided cables soldered to it for attachment to the radios, amplifiers, and antenna "**Trans-Match**". The ground rods themselves are also copper tubing which were hydrologically sunken (this is a technical way of saying, hook up a garden hose to the tube and let the water suck it into the ground). This method will push aside even grapefruit size rocks as it burrows into the ground.

Copper tubing is much less expensive per foot than is large diameter copper wire (I wish I had thought of that when I installed my system, because it's easier to solder as well). It has a larger diameter than most wire which lowers both its impedance and inductance. It can be easily soldered together using plumbing fittings, just as you would install water pipes. If you want to make a real bang up job of things use Silver solder to lower the impedance even more! Seal and weather proof all soldered joints!

2) Use several ground rods, and cover a large surface area. A large surface area is more important than ground rod depth! Longer rods are desirable though when possible. If it is possible, place ground rods in an area that is often irrigated. Wet soil improves soil conductivity, and helps reduce radio frequency noise.

3) Think about and sort out possible ground loops on various wavelength bands. Design your system to avoid ground loops on any band on which you operate.

Terms you should become convivial with, and use in your conceptual thinking process

Angle of radiation: The term "angle of radiation" and "signal gain" are virtually the same thing. A good

antenna that is high in the air, and also isolated from other random radiators provides the lowest radiation angle, and consequently, the furthest signal propagation.

Audio rectification: This is the condition that prevails when transistor and diode circuitry within telephones or other audio devices are within the "near field" of a radio signal. This same sort of diode junction detection can even be observed with the false switching of infrared detector outdoor lighting. In this last example, the RF signals forward bias the lamps switching circuitry.

***Current loop:** Any time a wire or assembly of wires form a loop, a current generator is formed. Whenever you impose generated current across a resistance, you produce voltage. In the case of this articles premise, this voltage represents unwanted signal radiation!

Feedline: This term depicts the generic and proper description of conductors that connect an antenna to the radio station. This "feedline" might be either coaxial cable, balanced "Ladder line", or even single conductor line (as in the feed system for a "Windom" antenna, and also "G-line").

Fundamental frequency: The fundamental or prime frequency at which an oscillator or "Exciter" operates. An example might be an oscillator or Exciter operating at 3.5 MHz. (See Harmonic)

Ham: The name by which radio experimenters identified themselves, prior to the implementation of Amateur Radio pursuant to the Federal Radio Bureaus, "Communications Act of 1934".

Harmonic: The multiple of some fundamental frequency. The second harmonic of

3.5 MHz. is 7.0 Mhz., or $2 \times 3.5 \text{ MHz.} = 7.0 \text{ MHz.}$

High current point: Radio frequency currents reverse every half wavelength. The high current point of maximum signal radiation is at the center of a half wavelength antenna.

Good engineering practice: Amateur Radio operators are required by law to construct and maintain their radio stations to the best "state of the art" good engineering practice.

Good grounding system: A grounding system that provides the lowest possible resistance or Alternating Current (AC) impedance, has the lowest AC inductance possible, and is designed so as to limit the re-radiation of fundamental or harmonic frequency energy.

Ground bus: A common point connection terminus that embodies the design criterion of a good grounding system.

Grounding conductor: This is the connecting link between the radio station equipment bus, and the nearest point of earth grounding connection.

Ground rod: The term used to describe the simplest device associated with any sort of electrical "earthing" practice.

***Ground loops:** Intrinsically the same thing as a Current Loop.

Grounding system: The entirety of a conceived and engineered plan for providing "earthing" parameters for radio or other electrical requirements.

Ground wave: One electrical component of the physics of low frequency radio propagation. In Amateur Radio practices, the 160 band is the only wavelength band that exhibits significant ground wave signal propagation.

Large surface contact area: In the context of this article, this term implies the best "current conductivity" to earth ground. In Alternating Current (AC) circuits (ergo radio) large surface contact provides both low inductance, and low impedance. (See also "Skin Effect")

Near field: The near field of radio frequency energy is that radiated energy within a several wavelengths of an antenna or other radiating source.

Odd order harmonic: The direct definition relates to the third, fifth, seventh, ninth, eleventh, and thirteenth multiples of a fundamental signal etc. A readily available example of an odd order harmonic in Amateur Radio practice is the means by which a 441 MHz. signal can be generated from a 147 MHz. source ($147 \times 3 = 441$). Another way of saying this is, the 70 centimeter band falls at the 3rd. Harmonic of the 2 meter Amateur Radio wavelength band. Odd order harmonics are easily propagated in contrast to "Even Order" harmonics which will self cancel.

Power mains: The generic description of the primary power distribution source (117 Volt Alternating Current, or 220 VAC etc.)

Radio frequency wavelength: The unit of radio signal measurement that embodies both the legal requirement of Amateur Radio station operation, and also depicts the physics by which radio signals propagate. Radio wavelength is determined by deviding frequency into the velocity by which that signal energy travels. Where $V =$ Velocity or 300,000,000 meters per second, and $f =$ Frequency (of oscillation) of the frequency in use. Example: $V f = \lambda$ $300 / 50 \text{ MHz.} = 6 \text{ meters}$

RF ground: A grounding system that by inference implies the qualities of low impedance, and low inductance.

Safety ground: A grounding system that by inference implies only a better electrical path to ground than the person or equipment being protected.

Skin effect: Alternating Currents, such as radio frequencies, flow only on the outside surface of conductors. By inference in this application, larger surface area equates to lower impedance and improved conductivity.

Short circuit: The situation that arises when a person or other conducting object is exposed to an electrical circuit between that circuit's source and load. The "short circuiting" object in this case, becomes the interim load.

Shunt feed: In the context of this article, this implies a system for "feeding" radio signal energy into a grounded metal tower, to make that tower function as an antenna.

Soft copper: The term soft copper refers to copper that is not produced with other metal content. In other words, it is just plain copper, not an alloy.

Hint: To expand upon the conceptual idea contained within the use of such metals, think about the concept of using other metals of low resistance! Just as a thought teaser, if the cost was not so exorbitant, would using silver plating on antennas or other RF conductors be desirable?

Station ground: A radio station grounding system where both electrical safety precautions as well as radio frequency transmission optimization have been provided.

Trans-match: This is the proper term for a transmitter to antenna system impedance matching coupler. This is often errantly referred to as an "Antenna Tuner". If the word *Antenna System* Tuner was inserted, the errant quality of the term would be mitigated.

Wavelength bands: A political distinction for allotting and cataloging portions of radio frequency spectrum. This term though embodies the physics by which radio signals propagate. (See: radio frequency wavelength)

Wavelength dimension: This term refers not only to unitary or single units of frequency wavelength such as 10 meters or 2 meters, it more importantly refers to thinking in terms of a dimension length. Example: 10 feet is .28 wavelengths at 28 MHz. (or a bit longer than a 1/4 wavelength).

The formula to calculate this is:

$$V f =$$

$$300 / 28 \text{ MHz.} = 10.7 \text{ meters}$$

$$10.7 \times 39.37 = 421.8 \text{ inches}$$

$$421.8 / 12 = 35.15 \text{ feet}$$

$$10 \text{ feet} / 35.15 = .28 \text{ wavelength}$$

Where V = Velocity of signal propagation, or 300,000,000 meters per second, and 39.37 = 1 meter as measured in inches

This same 10 foot physical length of wire becomes .253 wavelengths (still a bit over a quarter wavelength) at the 12 meter band, .508 wavelengths on the 6 meter band, and 1.46 wavelengths on the 2 meter band.

For our purposes in this article, anytime a piece of wire at your station approaches a 1/4 (.25) wavelength or longer, it isn't a ground conductor anymore! In fact it becomes a "**radiating element**", or you might say an antenna in its own right. This is bad news for a ground system!

Radiating element: a radiating element is any metallic conductor that is within the "**near field**" of a radio frequency energy source. This is usually specific length component elements of an antenna. It can be any piece of metal that is a significant percentage of the energizing wavelength frequency. Examples of such **unwanted** radiating elements might be, rain gutters, wire guy lines, or grounding conductors, any of which would have to be a quarter wavelength or longer at the energizing frequency.

[Home](#) | [Site Map](#) | [Calendar](#) | [e-mail](#) | [Links](#) | [Meetings](#)

Tech Bench Elmers λ © 1996-98

[K3MT](#)

presents . . .

The *GRASSWIRE* another approach to hidden HF antennas

April, 1997

Deed restrictions got you down? Neighbors intimidating your tower plans? Need a really *easy* portable HF antenna? Then the *grasswire* may be the answer! Virtually invisible, lightweight, and compact (you can carry one in your hip pocket), this antenna works! It has been used by K3MT in various installations for more than 10 years.

Read on - and listen to the "experts" telling you that this is hogwash, that an antenna like this can't work. But it does. And *true* experts, who have taken a decade or more to come to grips with the intricacies of Maxwell's Math, know *why* it works.

This antenna will *not* out-perform a yagi, or a decent dipole up a half wavelength. Not in gain or signal strength, at least. But it will survive an ice storm, wind storm, and is practically immune to lightning. And it doesn't need a large tower or tall support. I deploy one from my hip pocket at times - the balun to match it is larger than the antenna!

THE GRASSWIRE - IN BRIEF

What is it? Put simply, it is an end-fed, longwire antenna that is laid right on the grass. Hence the name. The original grasswire used by K3MT in the summer of 1988 was just 204' of #18 AWG magnet wire laid along the property line, anywhere from 1" to 6" above the ground. This sketch shows plan and elevation views of a typical installation. Both an 8' ground rod and optional counterpoise wires are shown. Use one or the other. Both are not needed.

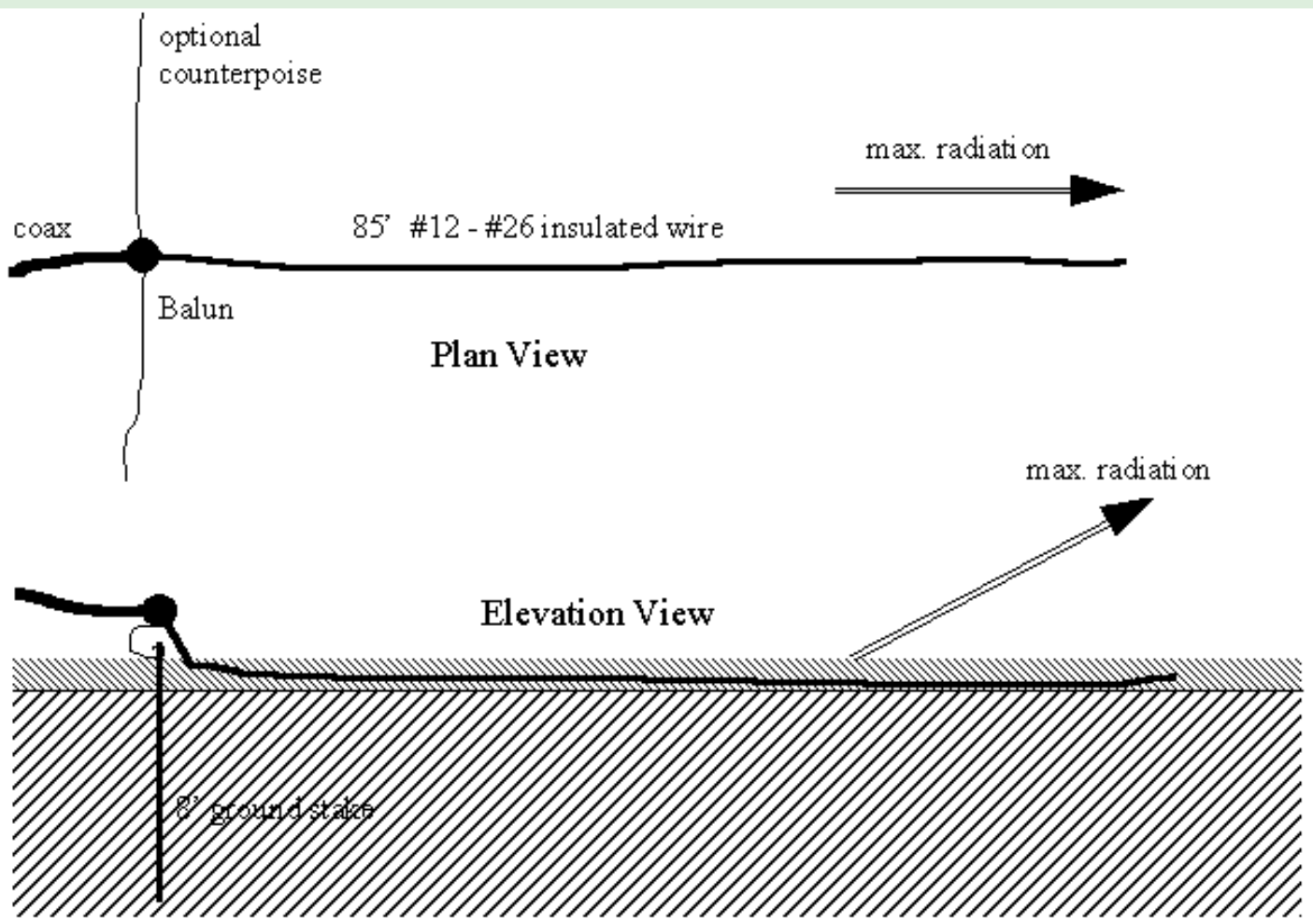

These antennas are largely resistive, with values ranging from 150 to 500 ohms or so on average ground. They have been used successfully on the average soils northwest of Washington, DC, on the sandy soils of the Cape Canaveral, Florida area, in the rocky, shale soils of the mountains in Somerset county, PA, and on river bottomland of Allegheny County, PA. One was used with great success by K3MT/VP9 in Southampton, Bermuda - the object of nightly pileups on 30 m CW for four nights.

REFLECTION AND THE BREWSTER ANGLE

The skeptic in you will doubt that such low antennas can work. After all, its image in the ground radiates and cancels out all radiation. True - if the ground is perfect. But nothing is perfect! The grasswire radiates *vertically polarized* off the *end* of the wire. Extensive monitoring tests with wires laid along the great circle route toward WWV, and perpendicular to that line, demonstrate the end-fire nature of the antenna. So why does it work?

When a plane wave reflects from an air-earth boundary, an incoming ray reflects, giving an outgoing ray. These two, and the line normal to the boundary plane, form

a *plane of incidence*. Solutions of Maxwell's equations differ for the case of the E-field being perpendicular to this plane (i.e., horizontally polarized), and the case when the E-field vector is *in* the plane of incidence. You will probably call the latter "vertical" polarization, although this is technically not correct. Electromagneticists (a.k.a those who practice Electromagical effects) refer to these cases as *normal* incidence (horizontal polarization) and *planar* incidence (vertical polarization.)

For the normal incidence case, reflection is nearly total, with a nearly 180 degree phase reversal. Thus very low antennas neither respond to, nor generate, appreciable amounts of horizontally polarized radiation. But for the planar incidence case, the reflection varies in strength considerably. At some *takeoff angle* (angle between outgoing ray and the ground) the reflection becomes quite weak, and has a 90 degree phase shift. Near this angle, the sum of direct and reflected rays will have a magnitude as if the antenna were in free space! Of course, at other angles, ground reflection largely cancels the direct ray, and the antenna does not radiate well at all.

A *reflection coefficient* is calculated as the ratio of the electric field in the incoming ray to the electric field in the reflected ray. It varies from one (total reflection without loss) to zero (no reflection at all.) It depends on the takeoff angle, frequency, and the soil parameters (dielectric constant and conductivity.) Here are plots of planar incident (vertical polarization) reflection for typical "good" and "poor" soils.

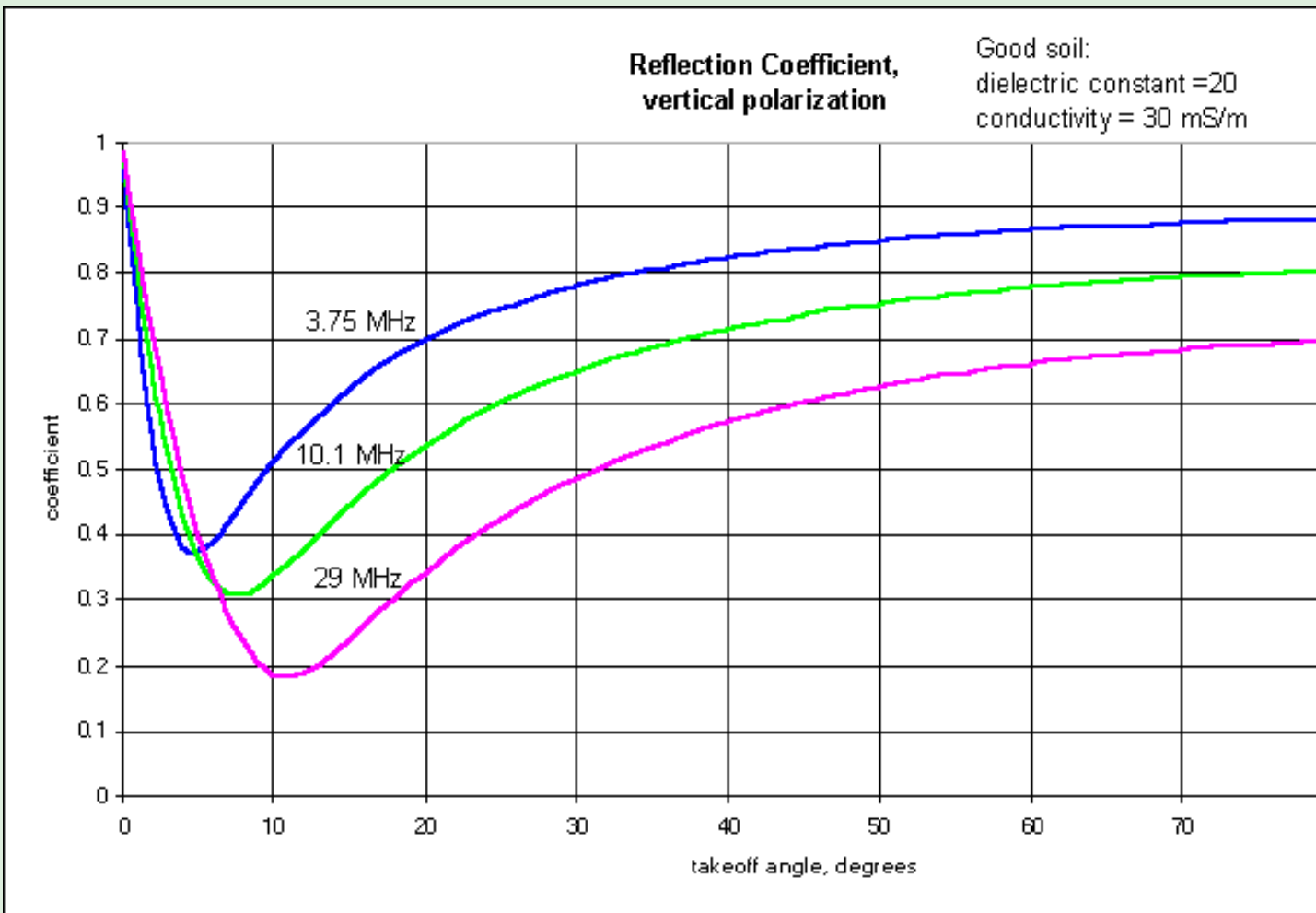

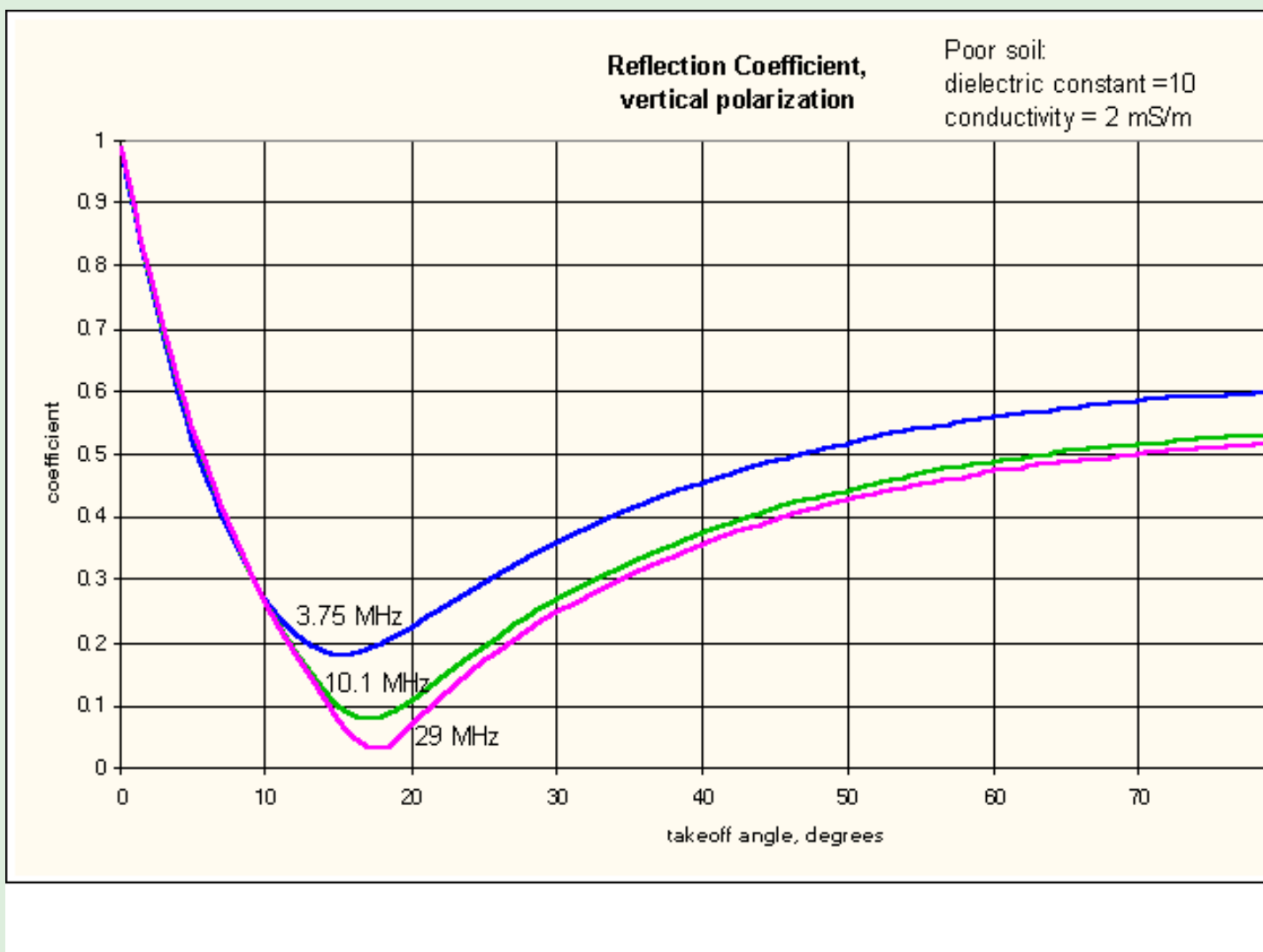

Notice that, at 10 to 25 degrees, the ground reflection is very weak. It also is shifted 90 degrees in phase from the incident ray. Therefore, radiation from the grasswire, off the ends will be about the same as if the ground were not present.

But launching a ray at, say, 15 to 20 degrees takeoff angle, in a direction toward Europe, can be useful! That's what a grasswire does. It is lossy in all directions, but least lossy when exciting the ionosphere for a long-haul DX contact. To demonstrate the point, here's an extract of K3MT's log, for October of 1988, (ahh, glory! Yes, the SSN was good then!) using a grasswire:

| Date | GMT | CALL | his/my RST | FREQ | Power | |
|------------------|------|--------|------------|-------|-------|-------|
| OCTOBER | | | | | | |
| 27 | 1554 | SM6DYK | 579 / 559 | 28004 | 80 | |
| | 1601 | SM0LBR | 569 / 439 | 21007 | 100 | RAY - |
| STOCKHOLM | | | | | | |

| | | | | | | |
|------------|--------|-----------|-----------|-------|--------------|--------------|
| 2001 | W4JBQ | 579 / 569 | 7029 | 40 | JOE - FT | |
| WRIGHT, KY | | | | | | |
| 2141 | W8LNJ | 579 / 459 | 28015 | 80 | DAVE - | |
| DALLAS, TX | | | | | | |
| 28 | 0227 | W8AO | 589 / 569 | 3547 | 15 | BOB - SILVER |
| LAKE, OH | | | | | | |
| 1720 | G3RFE | 579 / 559 | 21016 | 100 | TOM - BARROW | |
| 1932 | G0CBW | 569 / 559 | 14029 | 50 | MEL | |
| 1945 | VE2FOU | 589 / 559 | 7032 | 100 | ANDRE - | |
| IBERVILLE | | | | | | |
| 2026 | KB7UX | 569 / 539 | 21040 | 100 | RUSS - CHINO | |
| VALLEY, AZ | | | | | | |
| 2100 | I2JIN | 589 / 559 | 14022 | 40 | BOB - COMO | |
| 2123 | G3JVC | 569 / 559 | 14022 | 40 | JOHN - | |
| LONDON | | | | | | |
| 29 | 2105 | WA200JXT | 599 / 599 | 28015 | 80 | ND |

Not bad, for a wire on the ground. Notice that contacts were made on 80, 40, 20, 15, and 10 meters. The signal reports are not fantastic. But contacts were made, and ham radio was enjoyed! Five countries were worked in 3 days. And the best part of this setup: *the neighbors never knew that a ham station was on the air!*

FEEDING THE GRASSWIRE

Since this antenna is largely resistive, a simple trifilar balun is all that I have ever had to use. This sketch shows how to make a balun that works:

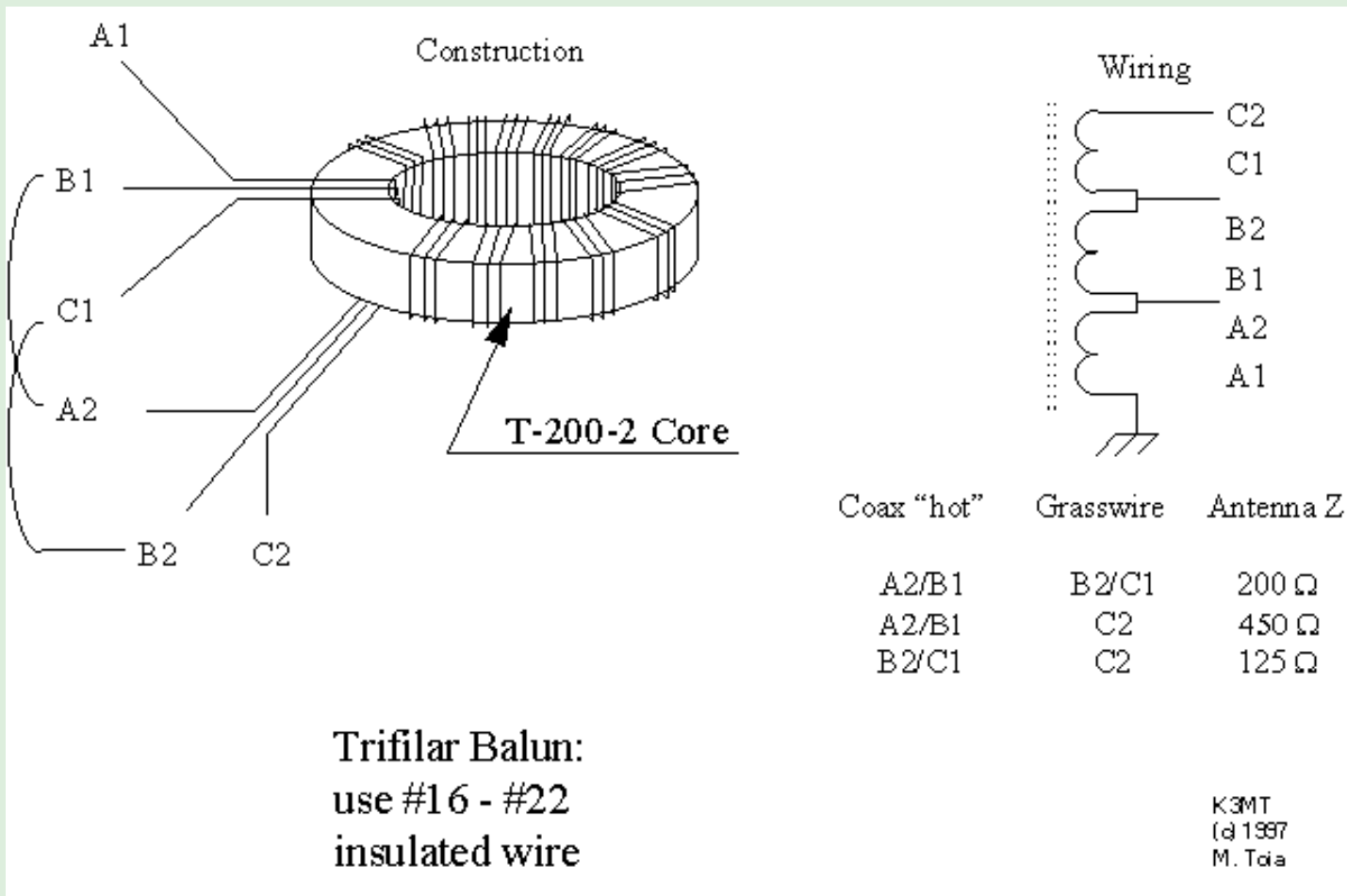

Typically I pull the insulation off of some indoor telephone wiring cable. Four insulated #22 copper wires are inside: discard one of these and use the remaining three. Wind about 16 turns on the core, without allowing the wire to twist (keep the three conductors parallel at all times.)

Notice that this "balun" really matches an unbalanced antenna to an unbalanced transmission line. It is basically a wide-band, three-winding autotransformer. Impedance ratios are as shown on the drawing. Generally it is necessary to connect the coax to either A2/B1 or B2/C1, and the antenna to B2/C1 or to C2. This may change from one band to another, and usually does.

WINDOM IN THE GRASS

I have elsewhere described a [windom antenna](#). While it is usually hung from a pole or in a tree, it works when used in a "grasswire" mode. Just lay it on the ground. Dimensions are repeated here for ready reference.

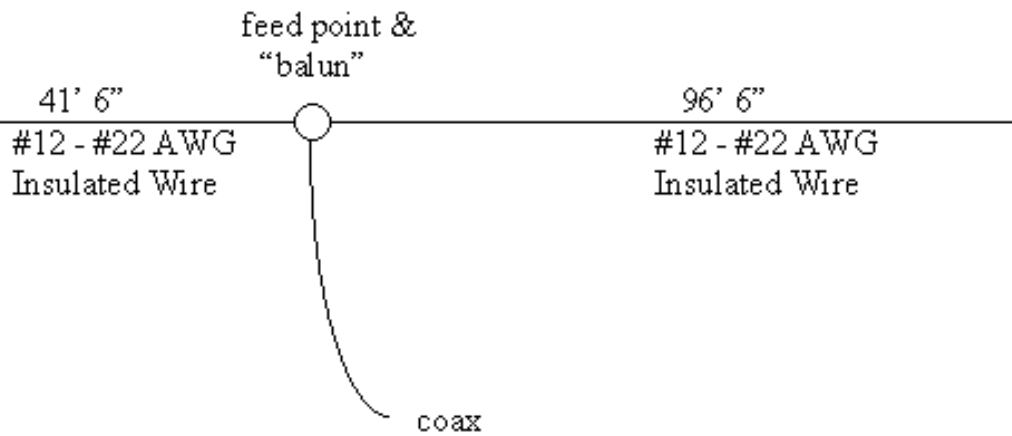

Off-center fed Windom
lay on grass
Trifilar "balun" transformer

K3MT
(c) 1997
M. Tola

When I travel, I take one of these made of #22 insulated hookup wire. Since I often set up beside motel parking lots, and often after a day's work, the longer wire is black, and the shorter one is red. This helps me determine which way to point the windom. Remember, though, that it fires *off the long end*. Of course, it fires the other way, too, but usually works best off the long end.

I hope this has given some of you a good case of curiosity. Go out and try one of these ground - mounted wires. They're easy to build. Even the balun is easy to build.

If you must, contact us: we can supply a core, a whole balun, or a whole grasswire windom setup.

For more unusual antennas, visit my [web page](#).

And check out my [Book](#) for a dozen topics about HF antennas. that includes the grasswire and other beverage antennas.



Bobtails and Half Squares

These antennas offer big gun DX performance on the low bands, yet they are surprisingly simple to build. Try one- you will like it!

ABOUT THESE ANTENNAS

Bobtails are vertical arrays that look like the letter "E" turned 90° clockwise onto its tails. They have 3 quarter wave vertical elements and are one wavelength long. The Half Square is a shortened Bobtail- it has 2 quarter wave vertical elements and is a half wave long. The tops of the verticals are all connected together by a wire or other conductor. The bottoms of the verticals are all insulated from ground. Bobtails are fed from the bottom of the middle element. Half squares may be fed at either end- it matters very little in the resulting pattern.

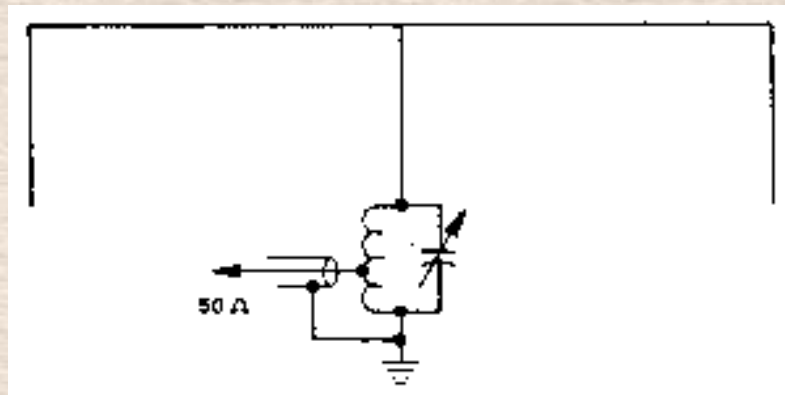

These antennas belong to the 'inverted ground plane' family. They work best *voltage-fed*, rather than current-fed. You should not connect coax directly to the tails. Current-fed antennas like the dipole have low impedance feedpoints and are a good match to coax. The impedance at the tips of a dipole is high, however- in the thousands of ohms, like the bobtail. Fortunately it is easy to voltage-feed the bobtail with a simple LC parallel resonant circuit connected between the element tip and ground. With the point of highest RF current a quarter wave up in the air, ground requirements are much less stringent than with ground-driven, current-fed verticals which need many radial wires to work well.

It is customary to use only a small ground screen as the feedpoint counterpoise. A 3 by 5 foot piece of wire cloth is often enough, even on 80 meters. It can be supported a few feet up or it can be laid directly on the ground or even on a roof. It works much better than a ground rod, which may be connected to the counterpoise but should be thought of only as a lightning ground. A coax feedline can be connected to a tap near the grounded end of the coil and the tap adjusted for best SWR, or even better, inductive link coupling can be used.

The horizontal pattern of a bobtail is a bidirectional figure 8 broadside to the plane of the antenna. The two lobes are rather narrow- only about 50°. It has a respectable gain of about 5dB over a

single vertical. The half square has a beamwidth of about 60° and a gain of about 4dB. *Apparent* gain for DX (over single verticals or low horizontal antennas) will seem to be greater. Both antennas have good side rejection that helps hear the DX better. The bobtail has a cleaner pattern that better rejects close-in noise and signals (some of your competition in the pileups.) The vertical angle of radiation is low, in the 20° to 30° range, depending on the conductivity of the local earth.

Note that the bobtail is primarily a low bands antenna useful on 30 meters and below. 30 is a transitional band where vertical and horizontal antennas both do well for DXing. For 20 meters and up, almost any horizontal antenna at reasonable height will usually do better than a vertical (unless your location happens to be over salt water.) I did build a 20 meter bobtail once in an emergency when the yagi atop my tower had failed and there was a DXpedition to a rare country coming up. The center tail was voltage-fed, with the feedpoint on my roof at about 17 feet. The stations I worked reported it had a potent signal. There have been favorable reports in the literature as well. Perhaps these antennas are underrated and underappreciated on the high bands. I doubt it is worth bothering with one for 20 meters and above, however, if you are able to put up a tower and yagi.

New bobtail owners often report great success with their antenna. It is designed for DXing, not for close-in work where low, horizontally polarized antennas are more appropriate. Mounted at heights of about 25-30 feet for 30 meters and 35-40 feet for 40 meters, these simple antennas deliver DX performance that rivals horizontal antennas in the 100+ foot class. Furthermore, at these heights it is practical to use trees or simple wood or metal masts to support the wires. Metal tubing or pipe masts can also double as the vertical elements. If you have tall trees as I do, 80 meters is not out of the question. Mounted at 70 feet, the tails of a wire 80m half square will be a few feet off the ground. I have used both a 40 meter bobtail and 80 meter half squares and was very pleased with them. I would not hesitate to build some again, under the right circumstances. They are a hard-to-beat combination of DX punch and simplicity.

More about Bobtails and Half Squares:

[Bobtail/Half Square Grounding and Feeding](#)

[Beverage and Half Square Bibliography \(includes articles by the inventor, W6BCX\)](#)

[Detailed plans for building matching networks for your favorite bands](#)

[Construction notes and important safety issues](#)

[User Comments from Bobtail and Half Square owners](#)

[Half Square/ Bobtail Articles Critique](#)

Bobtail and Half Square users: Please email your experiences with these antennas to be included in the User Comments section.

[EMAIL](#)

[Send Comments to K3KY](#)

[The Low Bands](#)

[PREV](#)

[HOME](#)

[K3KY's DX Toolbar](#)

[Grounding and Feeding](#)

[NEXT](#)

Web page created by K3KY. All original content including text and photos is Copyright © 1996, 1997, 1998, 1999, 2000, 2001, 2002 by David E. Sinclair. Use elsewhere without permission is expressly prohibited.

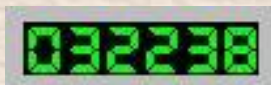

Elevated Half Square

KQ6RH

(C) 1998, 1999, 2000

Ray Jurgens

(Up-Dated 2/25/2000)

Elevated Half Square

The elevated half square antenna is a very simple antenna that can be constructed from common materials yet gives significant improvement over a dipole at the same elevation. Ground mounted versions of this antenna are commonly used in amateur radio for 75/80 and 160 meter bands. The elevated version described here provides even greater performance. The Half Square antenna is bi-directional, has a low angles of radiation, is self supporting, is easily erected, and can be rotated with a TV antenna rotator. The Elevated Half Square antenna achieves its high level of performance by not radiating power at high angles of elevation where it leaks through the ionosphere and by having its high current regions near the top of the antenna. Figures 1 and 2 show the radiation patterns in azimuth and elevation.

Half-Square Antenna

Ground Mounted
Azimuth

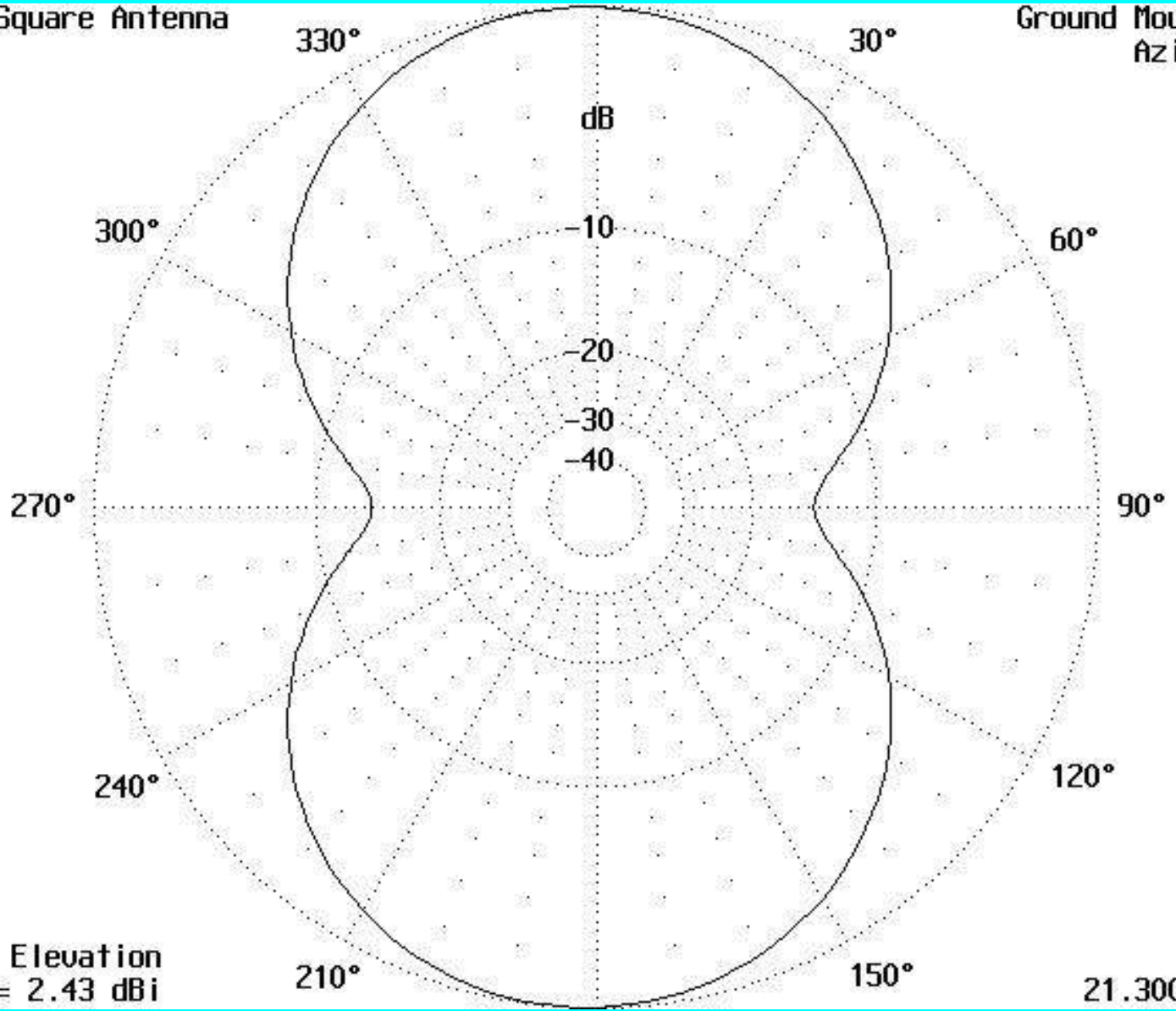
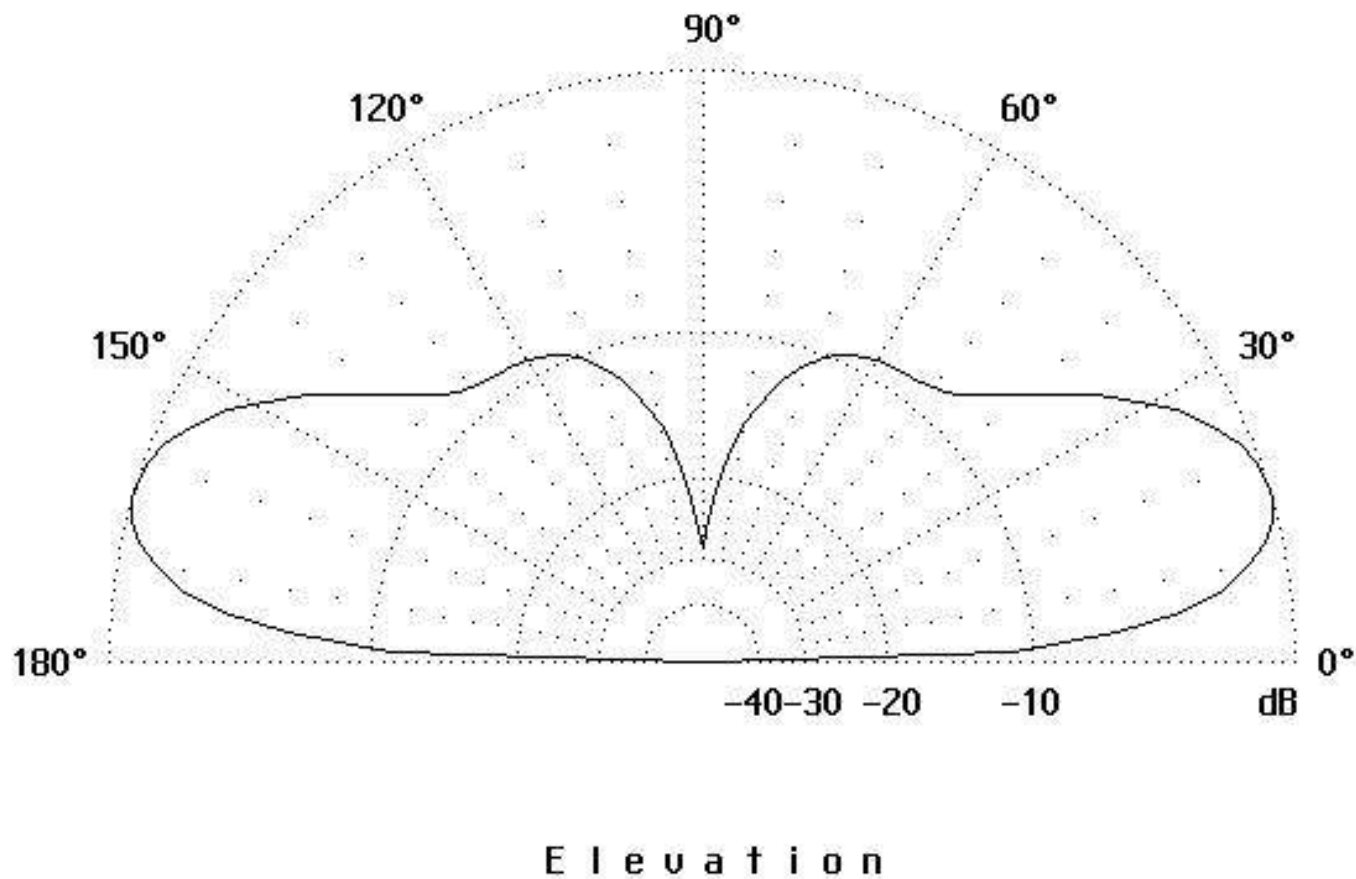

Figure 1

Azimuth Pattern at 10 Degrees Elevation



0 dB = 3.54 dBi

21.300 MHz

Figure 2

Elevation Pattern for the Elevated Half Square Antenna at 0 Degrees Azimuth

This is one of the best DX antennas you can find unless you just happen to be able to put a 3 element Yagi at 90 to 120 feet in the air. Note that high angle radiation (local QRM) is attenuated by as much as 10 dB, so if you are in the central US, coastal stations will be attenuated, and the Europeans and western Pacific regions will be given 3.54 dBi gain. Forget about using this antenna for local work.

The pictures below show two ways to construct this antenna. There is the neat and light version made with fiberglass structures and the cheap, heavy and ugly PVC version. So take your pick.



Figure 3

Fiberglass Version of the Elevated Half Square Showing Structure and Feed



Figure 4

PVC Version of the Elevated Half Square Showing the Structure

There are a number of tricks to the design of the Elevated Half Square, and our [Guide to the Elevated Half Square](#) gives the complete details of the corrections for propagation velocity in dielectric tubes, methods of decoupling the feed line from the radiating structure, the construction of light weight structures to support the antenna and a complete parts list for both fiberglass and PVC structures. These topics are too extensive to cover on a web site, so this guide is listed in our [Products Page](#).

[Return to Main Menu](#)

An End Fed Half Wave Antenna

Useful for portable work

A Half Wave End Fed Antenna G3YCC

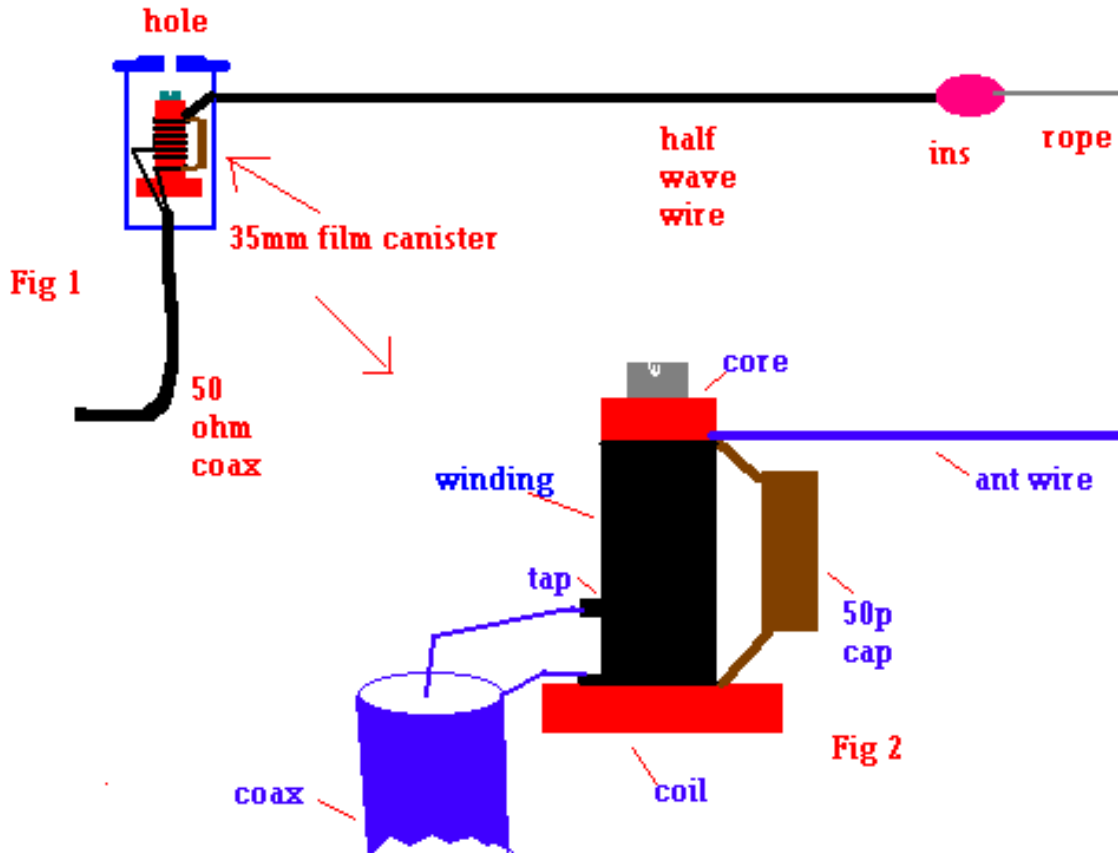

This end fed type of antenna was marketed in the UK and is a useful system for the portable set-up. Being a half wave, no radials or counterpoise wires are needed.

As the impedance will be high at the end of the wire, some form of matching unit is needed and a simple parallel tuned circuit housed in a plastic film container is fine (figure 1). A hole in the container allows for tuning, by adjusting the ferrite core in the coil for maximum reading on a field strength meter nearby.

The inner of the coax goes to a tap about 1/4 of the way from the earthy end of the winding, to which the braid of the coax is soldered.

As a rough guide, a capacitor of 50pf across a winding of say 30 turns is a starting point for 40m. Some experimenting with turns and tapping point is necessary. The coil former used was about 1/4 inches in diameter as found in old IF transformers.

The antenna wire (1/2 wave long) is soldered to the top of the coil as shown in figure 2.

The drawings illustrate the set up, I hope.

For portable use, throw the wire into a tree or whatever, using thin cord or rope onto the insulator (figure 1), tune for best field strength reading and off you go!

Try it - it works!

Want to work two bands? Use a slightly bigger container with two tuned circuits which have some sort of terminal each, to which one of their respective wires can be connected.

Rough lengths of half wave wires:

80m - 132 feet, 40m - 66 feet, 20m - 33 feet.

Enjoy your portable working and how about telling me what you thought of the above idea - when you have used it?

[Back to the first page](#)

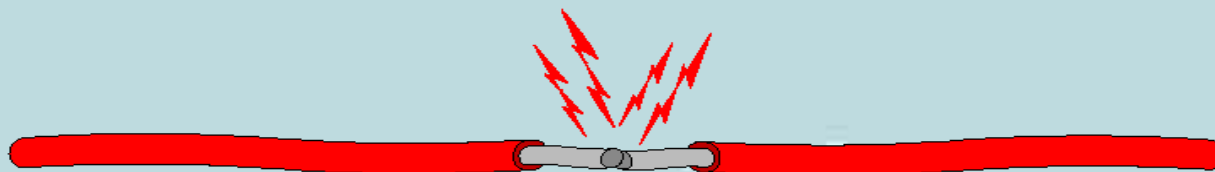

End fed-Halfe-wave antenna

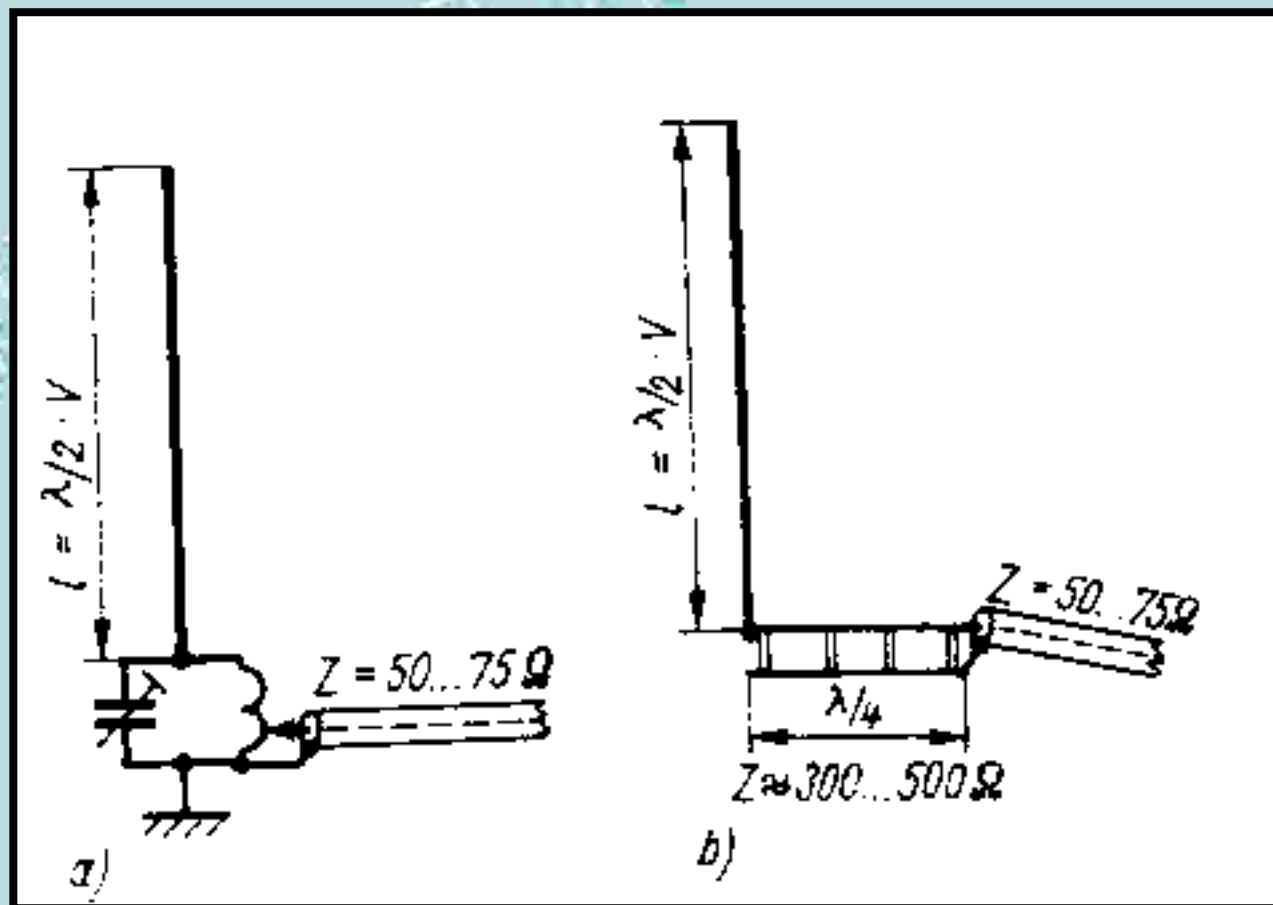
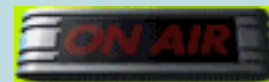

This type of antenna has same performance as a dipole, but requires only one single mounting point, which makes this concept ideal for portabel stations. Actual bandwidth is more than 2 Mhz with VSWR better than 1:1,7 !

For 14 Mhz you need approx. 10 meters of wire, abt. 4,7m coax-cable 50Ohm or 300Ohm with a connector about 30cm from the shortend. No tuner is required. We used this antenna on all our holiday - Dxpeditons : [8Q7BZ](http://www.qsl.net/oe3mzc) and in SV8, EA8, SV9,

Build this antenna system in less than 30 minutes and have fun and good DX.



[top of page](#) | [home](#) | [propagation](#) | [field strength meter](#) | [1270 Mhz antenna](#) | [Maldives Dxpediton](#) | [Web receivers](#)

You are visitor number:

135536

Visit other Amateur Radio Sites:



 **AR-RING**
The easy way to tour Amateur
Radio Sites on the Web!

[AR-Ring Home Page](#)

[Previous](#) [Next Five](#)

**Z
E
N
T**

2 METER HALO ANTENNA

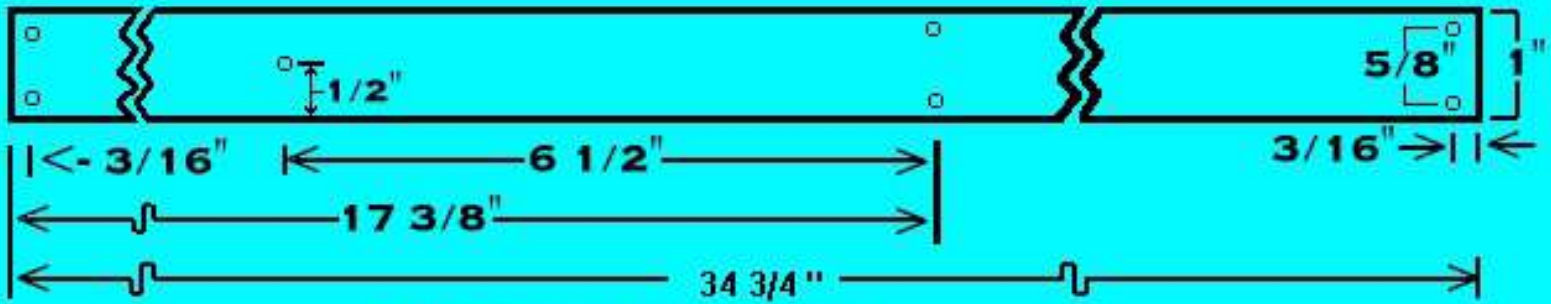

**.040 THICK ALUMINUM
DRILL 7 - #23 HOLES**

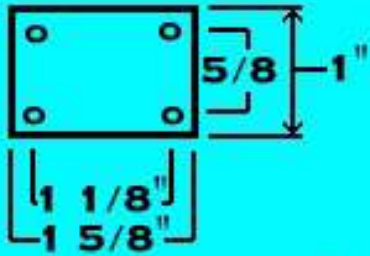

**INSULATOR 1/16" THICK FIBERGLASS
DRILL 4- #23 HOLES**



**3/8" O.D. TUBING
(FLATEN END
AS SHOWN)**



INSIDE CONDUCTOR OF RG-8/U CABLE

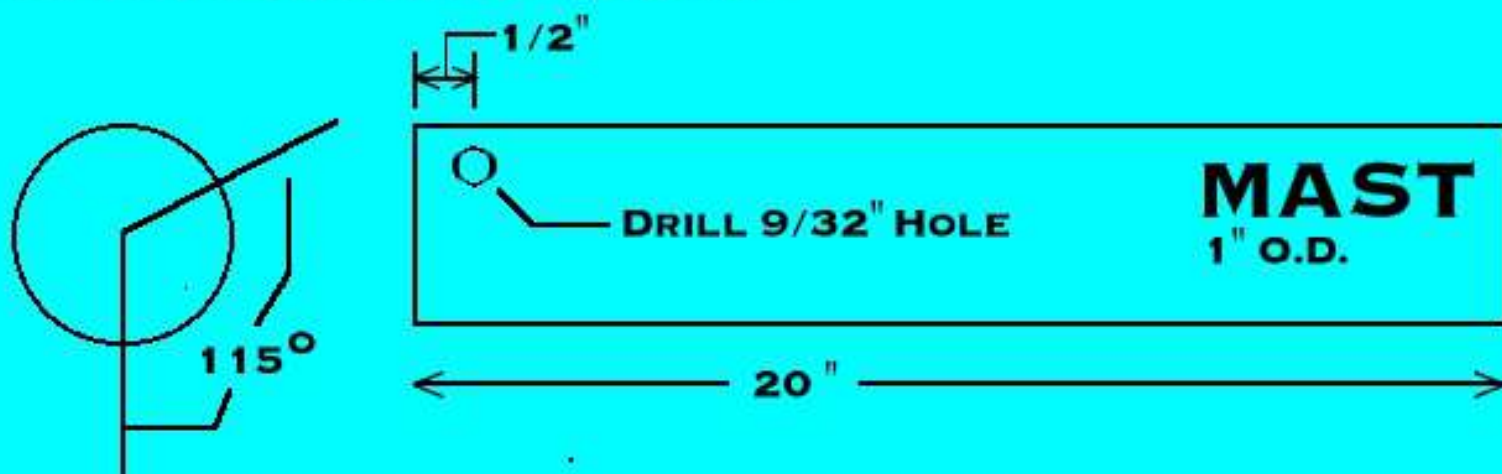

THE HALO ANTENNA IS BUILT OUT OF LIGHTWEIGHT MATERIAL. THE ELEMENT IS MADE FROM FLAT STOCK ALUMINUM THIN ENOUGH SO THAT IT WILL BOW INTO A CIRCLE. THE GAMMA MATCH IS MADE FROM A PIECE OF $3/8$ TUBING. THE OTHER PART OF THE GAMMA IS MADE FROM THE INNER CONDUCTOR OF RG-8/U CABLE. IF YOU BUILT THIS ANTENNA AS SHOWN THE SWR WILL BE BELOW 2:1 ACROSS THE 144-148 MHZ.



[Click here to return to front page](#)

N4UJW

AF4AR/W6ARQ

KC5BBP

"modified"

2 METER SQUARE LOOP

*GET ON 2 SSB IN STYLE WITH THIS NEEEEET AND STURDY PLUMBER'S
DELIGHT RF PROJECTOR !
LOOK DOWN BELOW FOR ALL THE GOODIES!*

BLAST OFF!!

BEWARE OF THE SHOCK WAVE!

**ADJUSTING SCREWS FOR
TWEAKING SWR**

MIKE (AF4AR)

RICK (KC5BBP)

JOHN (W6ARQ)

*CAN BE FOUND ON THE 146.67MHZ
NASHVILLE, TN AREA
MACHINE MUMBLING SOMETHING
ABOUT GRID SQUARES AND DX IN
THEIR SPARE TIME!*

**EMAIL THEM
FOR QUESTIONS**

Here are the building instructions on the 2 meter square loop.

Credit is given to K0FF for most of this design.

We have added modifications that proved useful in the design.

The mods will be presented under modifications in the design instructions. Special thanks to **W6ARQ** and, **KC5BBP** for thier input on this Antenna.

2 Meter Square Dipole by K0FF

Here is the parts list and dim. sheet for the 2 meter square dipole, made of copper water pipe.

Parts List

1/2 Inch Copper Water Pipe

Long Sides 9 1/2 inches

Open Ends 3 1/4

2 Short Pieces on each side of "T" 4 7/16

4-90 Degree Elbows
2-Copper Caps
1 Copper Tee
Brass Plate for SO239
Gamma Tube 4 3/4 of 3/8 Copper Tubing
RG8 is 5 1/2 inches long
Copper or Brass Gamma Tube Bracket
SO239

Modification Parts (DO NOT USE STAINLESS STEEL)

6 Brass Nuts-Note Any size
2 Brass Screws at least 1 1/2 long

Instructions The mounting array to be affixed to a standard mobile mast that presents 3/8 X 24 threads.

Run coaxial cable right to the antenna and connect it to the built in SO-239.

There are two adjustments on the Antenna to match the coax Imp.

Adjust the Gamma Match Tube for Lowest SWR, then the tuneable stubs move in or out for lower swr.

Do not use Stainless Steel Screws, Soldering them to the end caps is almost impossible.

The 2 meter square loop is a folded Dipole around itself.

The shape is 11" X 11".

Solder the antenna parts together using 90 degree elbows at the corner open ends and mind the gap.

All measurements are critical. The brass plate to hold them form an "L" 1-3/4" tall with a 1/2" lip.

A 5/8" hole is provided 1-1/4 inch from the bend, and attached using stainless steel or brass hardware.

Two small holes are drilled in the lip and mounted to the copper TEE with #6 self tapping screws.

Solder the 5 1/2 inch piece of RG8 to the SO-239.

When using the RG8 discard the outer shield and use only the Dielectric. Slip the RG8 inside the 4-3/4 Gamma Tube.

The Gamma bracket should be at least 1 1/2" long brass or copper.

Secure with stainless steel screws right before the 90 degree elbow.

Either side doesn't matter.

The Gap between the Open Ends is 2-3/8".

Adjustments to the gap in or out can be made with the modification of installing the brass screws on the end caps.

The Antenna is more or less Omni Directional and horizontally polarized.

It presents a high takeoff angle and is intended for use in the 144.200mhz area.

The Antenna can handle 100 Watts and has proved useful in working some satellites such as AO-27.

The Antenna provides excellent SSB results while mobile and have talked with other stations 200 miles with similarly equipped Antennas.

For further Information on assembly or instruction details Email the following hams below.

Af4ar6077@aol.com

W6arq@charter.net

Kc5bbp lives too far back in the hills of Tennessee to get daylight...much less email!!!!

I have found this Antenna works very well and, is a solid performer.

Best of luck with your Antenna.

EXPERIMENT! EXPERIMENT! EXPERIMENT!

73

Mike Gunter/Af4ar

Murfreesboro,Tn

[See the original design on eham.net](#)

***THESE INSTRUCTIONS WILL GET YOU ON YOUR WAY
TO 2 METER SSB EXCITEMENT!.***

PLEASE DON'T EMAIL
HAM UNIVERSE.COM
FOR QUESTIONS
PERTAINING TO THIS
ANTENNA..GO TO THE
EXPERTS ABOVE!!

**FELL FREE TO COPY
ANY OR ALL
THE INFO ON THIS
PAGE AND LET US
KNOW HOW IT
PERFORMED!
LISTENING FOR YOU
ON 2 SSB**

CREDITS

PHOTOS>>>>W6ARQ

HARD WORK>>>>AF4AR W6ARQ KC5BBP

PAGE "MASTER">>>>N4UJW

(from an article by KOFF on EHAM.NET)

BACK TO ANTENNA LAB

"TRY IT... YOU'LL LIKE IT!"

DID THIS PAGE LOAD SLOWLY? CHECK THIS OUT

DID YOU WANT TO BUY SOMETHING WHILE ON THE WEB?

**CHECK OUT
THE STORE WINDOW**



THE FRUIT OF THEIR EFFORTS

**AF4AR USES THIS
ANTENNA
MOBILE ON AN
18 WHEELER!
FILM AT
ELEVEN!**

**AF4AR/W6ARQ
KC5BBP**



VIEW FROM THE EARTH

GAMMA MATCH

**AF4AR/W6ARQ
KC5BBP**

SEE CLOSEUP BELOW >>>>



**AF4AR/W6ARQ
KC5BBP**



MOUNTING PARTS



MOUNT ASSEMBLED

SEE CLOSEUP BELOW



**LOTS OF GRAPHICS---
ALLOW TIME TO
LOAD!**

**2 METER SSB ANTENNA
PROJECT**

**THIS PAGE LINKED AROUND THE
WORLD!
OUR THANKS TO ALL! 73 N4UJW**

Click here to schedule your Free Installation!



**NEED A 6 METER
LOOP?
CLICK HERE
FOR PLANS AND
PICTURES**

NEW

Call your loved ones for only 4.5 cents per minute at LowerMyBills.com. No hidden fees, no monthly charges!



Satellite TV the way I want it!
No Equipment to buy!

Why pay full retail for inkjet supplies when you can save between 50%-70%! [Click here and start saving!](#)



ATTENTION!

What antenna project or computer program would you like to see here??

Our crews will do their best to add it!

[Contact us!](#)

PLEASE HELP KEEP HAMUNIVERSE

FREE

CLICK HERE

[Click Here for Thousands of Electronic Parts-Related Items and Accessories](#)

HOME BREW 6M HALO

Built for Mobile Use



**Jonesy
W3DHJ**

The Jones version of the Lawn Chair 6M Halo as viewed thru the rear window of the mobile. Ain't that just the sexiest thing you've ever seen on the outside of a vehicle?

I read the article: [Six Meters from Your Easy Chair](#) by Dick Stroud, W9SR in the January, 2002 QST with some interest. Dick described a 6M Halo antenna that was built from the aluminum frame of a 'generic' lawn chair. It is always a pleasure to peer into the working mind of another homebrewer and scrounger.

However, I put the article and the idea aside, because I had no interest in a 6M *vertical* antenna for this QTH (nor, for mobile operation, either.) And, that was how the antenna was 'portrayed' in the article. However, later in the Summer of 2002, I became Very Interested in improving my meager 6M mobile operation. Heretofore, I had been running 10W out of an ancient IC-551 into a 2M 5/8 wavelength whip -- which 'worked' well as a base-loaded 6M 1/4 wave vertical -- but, probably radiated like crap. I knew deep in my heart that it was not 'fair' to the other op to have to try to copy my peanut whistle.

Harmonic Convergence: It came to pass that one day I was

A: Pondering a better antenna for 6M mobile.

B: Thinking of a better transceiver for 6M mobile.

C: Feeling that the stock market hadn't really hurt me **that**much.

D: Reading the email copy of the "["AURORA REPEATER ASSOCIATION SWAPLIST"](#)

There was a used IC-706II listed for sale. Whoa!, I thought. That'll give me 100W on 6M -- it'll do mobile Quite Nicely -- and, to boot, I could dabble in HF mobile. I whipped out my checkbook and became the proud owner of the newest rig in my collection. (I had been using 2 TS-520's, an IC-551, and an IC-251A. I am soooo Last Century.)

While waiting for the UPS Man to drop off my new rig, I had time to ponder just exactly how I was going to 'solve' the 6M mobile antenna problem. I looked at several of the 'commercial' 6M halos that are available. They all looked FB, and the prices were not out of line. But, the Olde Home Brewer and Scrounger was already feeling guilty for **buying** a transceiver. So, I toyed some with the idea of homebrewing the antenna. I played mental games with a few ideas, and eventually circled back to the January, 2002 QST article. Hmmmmmm.... I wondered if I couldn't scratch out something along those lines that would both: radiate horizontally and do 85 MPH?

Well, I think I succeeded. And that explains this website. On the following web pages I hope to explain my thinking, design, material selection, construction techniques, and (yes) mistakes.

These web pages about my homebrew construction of a Six Meter Mobile Halo are dedicated to the first Jonesy, W3DHJ. Nearly all my homebrewing and scrounging skills were taught to me by my dad. I'd like to think he'd be proud of this antenna.

Constructive comments and/or discussions:

W3DHJ@arrl.net

[> 6M Halo - Project Beginnings.](#)

[< W3DHJ Home Page.](#)

HAM UNIVERSE

THE HENTENNA RE-VISITED

The Hentenna was developed by Japanese 6 Meter Hams, JE1DEU / JH1FCZ/ JH1YST in the 1970's and can be designed and built for hf thru uhf and possibly beyond!

After much experimentation, finally, the antenna was developed with good performance, however, it was difficult to explain why the performance was so good, or how it is worked basically at that time. So it was named Hentenna , "Hen" means strange in Japanese.

The antenna has good performance and many advantages and it has become very popular in Japan. Many JA stations make it and enjoy it at home or in the field. Some Japanese 6m beacon stations are using the Hentenna antenna.

HERE ARE SOME GOOD POINTS FOR THE HENTENNA

1. Good performance

2.5-3 dBd gain

Low angle radiation

* Total performance is equivalent to 2-3 element Yagi-uda antenna,

Wide band width

2. Easy to make

It is possible to adjust impedance and SWR perfectly, This means, not so difficult to make! No special parts are required. You can use any electrical conductor to make the main rectangle.

Broad adjustmentwide bandwidth

3. Easy to build up

If you use thin aluminum pipe and thin wire, you can make this antenna for 6m very light.

This means, it is easy to put it in a higher position in the air. You can also use light mast for it.

As this is a vertically long antenna, it is easy to install the antenna on a veranda or small space.

It appears to be a vertical antenna but has mainly Horizontal radiation: This is one of the reasons this antenna is "Hen".(STRANGE)

"The following article has been re-edited for the English language from the Japanese site and we discovered some minor errors so corrections were made."

N4UJW

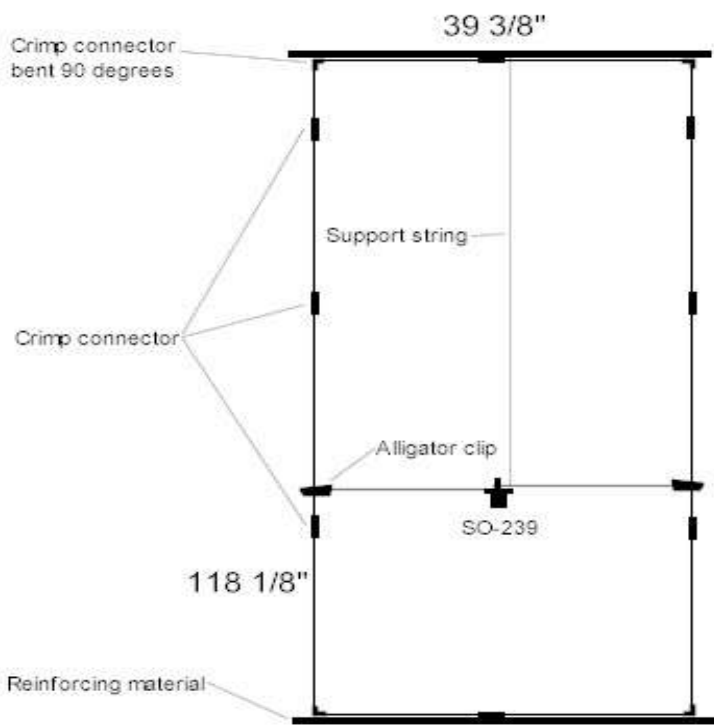
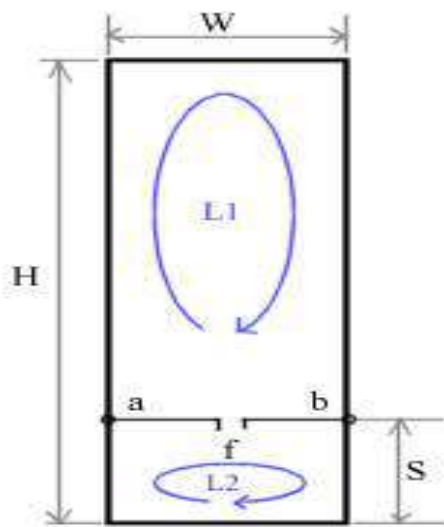

Japan version

English version

Please note in the above English drawings that the Hentenna is basically a loop fed about 1/10 wavelength from the bottom element with 50 or 75 ohm coax attached to the top element of the bottom loop at the center point.

Hentenna Basics

1. Basically 1 1/3 WL Loop antenna around outer edge of antenna
2. L1 works as 1 loop antenna
3. L2 works as matching section
4. Vertical long rectangle has more gain than ordinary square loop and has less impedance. L2 helps the matching and low angle radiation.
5. 3D pattern is like shell of peanut (maximum gain directions looking at you and away from you) so it will be somewhat bi-directional.

How to Adjust

1. Move the "a" and "b" points to adjust swr. (move in equal amounts)
S1 > S Matching Frequency UP (move towards top to increase resonant frequency)
S1 < S (move towards bottom to decrease resonant frequency).

2. SWR may be higher than 1:1.5 at first so move matching points "a" and "b" in small increments up or down the loop until lowest swr is obtained and secure at these points with whatever method you choose depending on your construction materials.

Putting it in the air and on the air

The construction materials you use for the loop will determine how the antenna is supported. It will weigh more if made from aluminum or copper tube and will require a non conductive support mast or structure to attach it even if made from wire. Nylon cord or rope or other non conductive material can be used for support at the four corners.

A length of pvc pipe can be used as support for the top, bottom and coax feed point elements with the side wires strung between them or can be used to completely enclose the wire. Use your own design. **Most JA hams use wire construction.**

The final configuration in the air should be as close to a vertical rectangle as possible.

This antenna is horizontally polarized.....lay it on it's side for vertical polarity!

Experiment with your favorite support and try to keep conductor size under 1/4 inch.

[See the Japan site link below for more info.](#)

6 Meter Version

THE MATH

Calculating the lengths for the Hentenna is simple and straightforward and can be used for HF THRU UHF and possibly beyond.

Just start with 1 meter = 39.36 inches

1 inch = 2.54 cm

1 wavelength = 6 meters = 6 x 39.36 = 236.16 inches

1/2 wavelength per side = 3 x 39.36 = 118.08 inches

1/6 wavelength = 6/6 = 1 wavelength = 39.36 inches

1/10 wavelength = 236.16 x .1 = 23.61 inches

Some adjustment of lengths may be required for peaking at design frequency. Experiment!

From the above calculations we arrive at the lengths for the Hentenna:

1/2 wavelength sides = 118.08 inches each

1/6 wavelength top, bottom and coax connection element = 39.36 inches

1/10 wavelength matching point = 23.61 inches up from each side of bottom element.



**New
6 Meter Hentenna
by
Charlie
KK5USS
SEE BOTTOM OF
PAGE!**

W5DXP's No-Tuner, All-HF-Band, Horizontal, Center-Fed Antenna

No-Tuner All-HF-Band Antenna

130 ft. centerfed dipole 37 ft. in the air

50 ohm SWRs at a current maximum

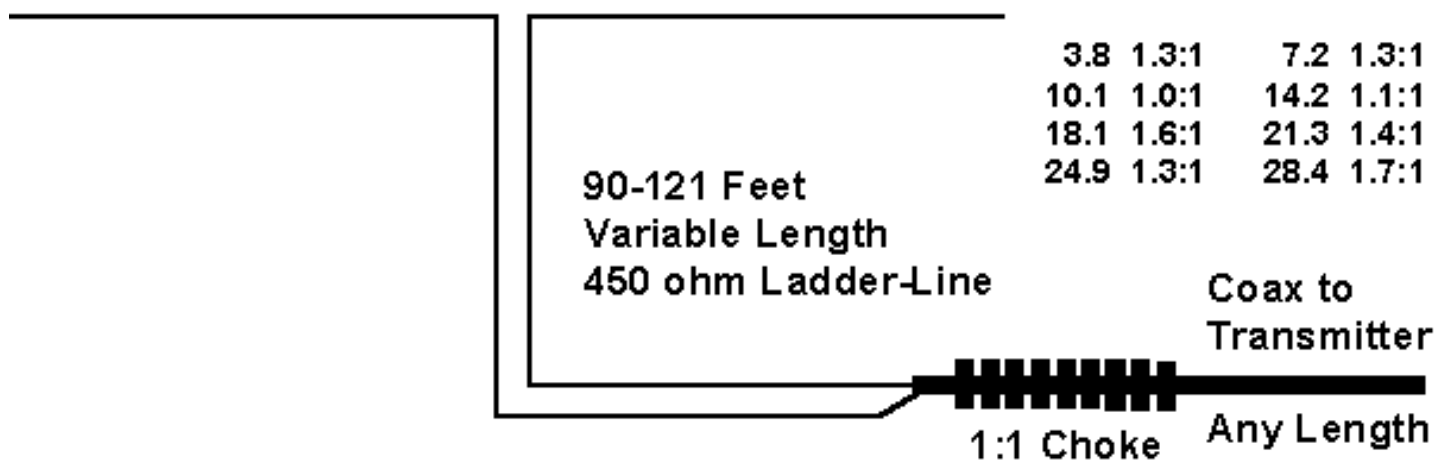

Ferrite beads for the 1:1 choke are available from Amidon Associates
 Ten of the FB-77-5621 beads will work for RG-58
 Fourteen of the FB-77-1024 beads will work for RG-213
 Thirty of the FB-77-6301 beads will work for RG-174 or RG-316 (Teflon)

The No-Tuner, All-HF-Band, Horizontal, Center-Fed Antenna is our old friend, the 80 meter halfwave dipole dressed up a bit. By varying the length of the 450 ohm ladder-line feeding the antenna, we can achieve an SWR of less than 2:1 on all frequencies on all HF bands with the exception of the lowest part of 80m. On 75m, we are feeding the antenna with a half-wavelength of ladder-line. On 40m, we are feeding it with 3/4 wavelength of ladder-line.

No antenna pruning required. My transmission line really does tune my antenna system.

Special thanks to Walt Maxwell, W2DU and Jim Bromley, K7JEB.

Ladder-Line Length Selector for Our All-Band Dipole

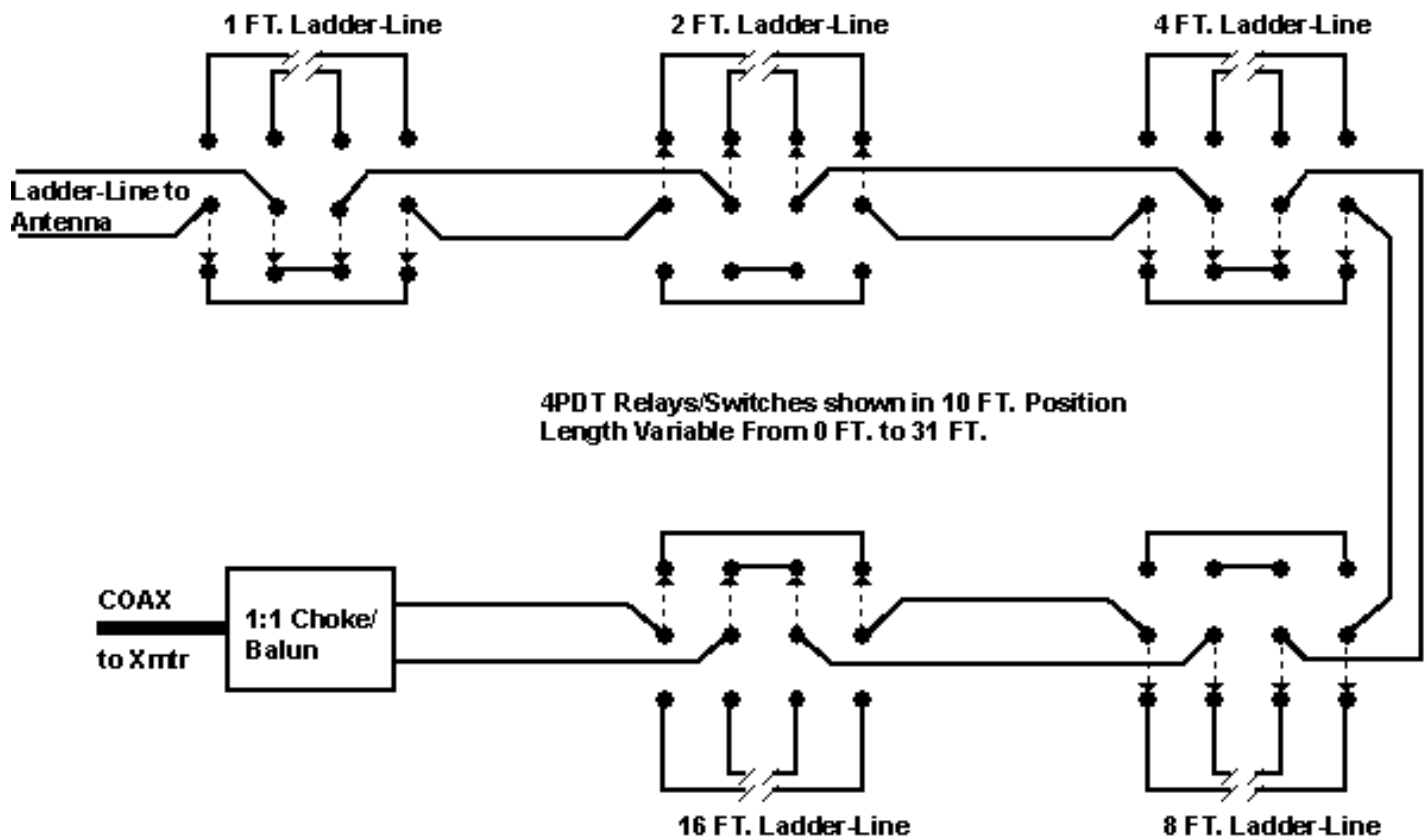

The length is continuously adjustable in one foot increments from zero to 31 feet.

The Ladder-Line Length Selector actually does tune the antenna system so no conventional "antenna tuner" is needed - no coils and no capacitors. Switches or relays (remote control) can be used for the switching function and should be sized according to the RF power levels involved. W5DXP presently uses ten DPDT Knife switches attached to a piece of plexiglas mounted in the hamshack window. For portable or backpacking use, the length selector function can be performed simply by 1/2/4/8/16 foot pieces of ladder-line with mating connectors on the end. The proper length of ladder-line is selected to cause resonance in the antenna system.

Here's a table that explains it all. The transmission line always consists of a

matching section and from zero to six halfwavelengths of ladder-line. The impedance at the antenna is shown along with the 450 ohm SWR and the impedance at the transmitter is shown along with the 50 ohm SWR, i.e. the SWR seen by the transmitter.

| ..Freq-MHz.. | ..T-line length = Matching Section + 1/2WL's.. | ..Impedance at XMTR.. | ..50 ohm SWR.. | ..Impedance at Antenna.. | ..450 ohm SWR.. |
|--------------|--|-----------------------|-------------------|-----------------------------|--------------------|
| 3.8 | 109.5' = 109.5' + 0 | 69 ohms | 1.4:1 | 71+j84 | 6.6:1 |
| 7.2 | 92.0' = 30.5' + 1x61.5' | 40 ohms | 1.2:1 | 4939-j716 | 11.2:1 |
| 10.125 | 99.4' = 12.0' + 2x43.7' | 50 ohms | 1.0:1 | 116-j510 | 9.1:1 |
| 14.2 | 110.2'' = 16.6' + 3x31.2' | 53 ohms | 1.1:1 | 2120+j1886 | 8.5:1 |
| 18.14 | 101.9' = 4.3' + 4x24.4' | 81 ohms | 1.6:1 | 111-j267 | 5.5:1 |
| 21.3 | 94.8' = 11.6' + 4x20.8' | 70 ohms | 1.4:1 | 1210+j1378 | 6.4:1 |
| 24.95 | 94.1' = 5.35' + 5x17.75' | 65 ohms | 1.3:1 | 186-j593 | 6.9:1 |
| 28.4 | 102.8' = 9.2' + 6x15.6' | 87 ohms | 1.7:1 | 721+j1009 | 5.2:1 |

[75M Graphs](#) [40M Graphs](#) [30M Graphs](#) [20M Graphs](#) [17M Graphs](#) [15M Graphs](#) [12M Graphs](#) [10M Graphs](#)



Here are the ten DPDT switches mounted on a piece of plexiglas that mounts in W5DXP's hamshack window. It shows the ten DPDT switches with the one foot, two feet, and four feet loops installed. The eight feet and 16 feet loops are not installed yet in this picture. RF flow is right to left from banana socket set to banana socket set. When installed in the hamshack window, the switches are on the inside and the loops of ladder-line are on the outside.

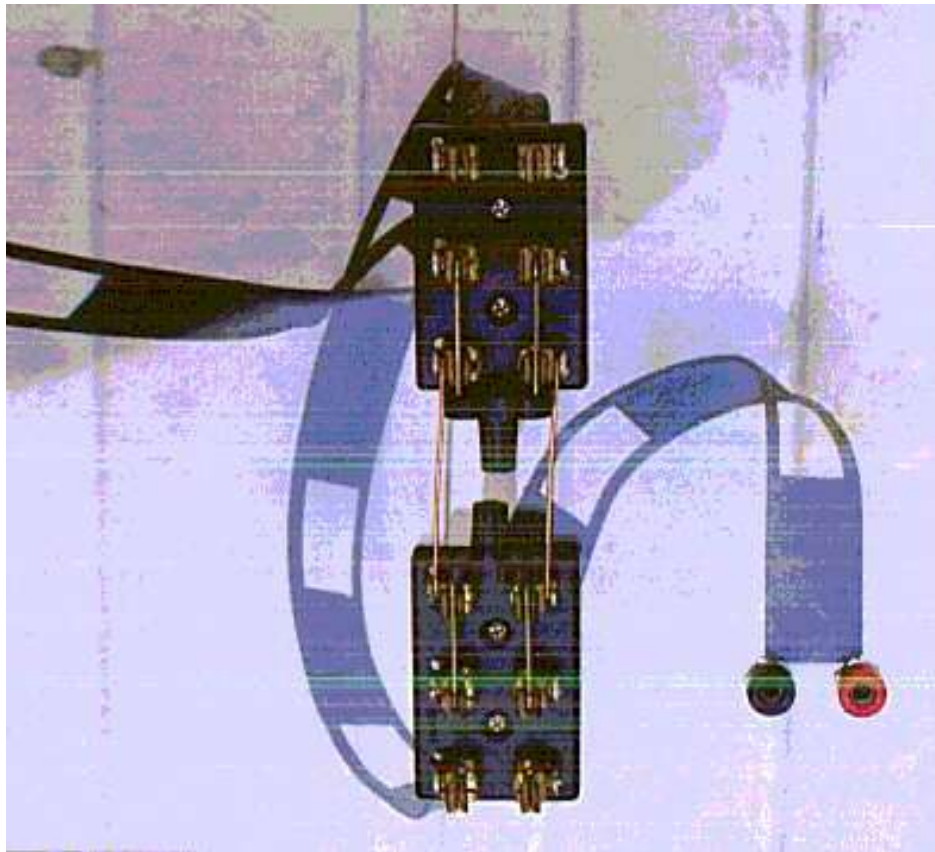

Here's a close up view of the one foot section. The RF flow is right to left into the banana sockets. The switches are shown in the shorted position, i.e. the one foot loop is floating completely out of the circuit to avoid capacitive effects. The bare copper wires in the center are the short. When the switches are thrown into the other position, the one foot loop is inserted into the circuit and the short is completely out of the circuit. This is the cleanest mechanical configuration W5DXP could think of but there might be a better way.

Distance in ft. from a 130 ft. dipole fed with 450 ohm ladder-line to current maximum points

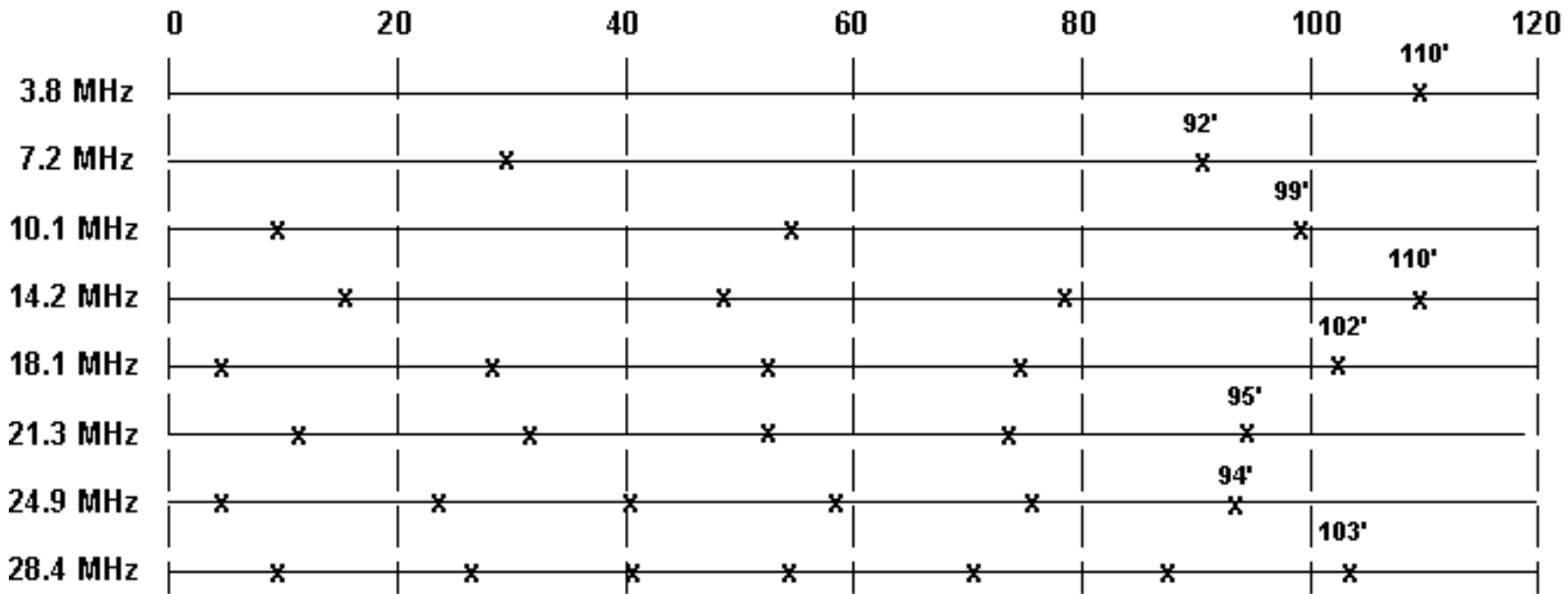

X - Current Maximum Point

This is a plot of all the current maximum points between the antenna and W5DXP's shack. The transmission line is 90 feet long and the Ladder-Line Length Selector can add in an additional zero to 31 feet for a total of 90 feet to 121 feet. 90 feet matches the antenna on about 7.3 MHz and 121 feet matches the antenna on about 3.6 MHz. The matching points for all the other HF bands lie between these two extremes. Note that if a fixed length of ladder-line needs to be chosen for best results with this antenna, that length should be around 100 ft. which should work with internal autotuners. Caution: Do not expect a similar antenna erected in a different location to exactly match W5DXP's results. The antenna environment has a large effect on the antenna characteristics so W5DXP's results are only approximations when applied to other antenna locations and environments. Mounting this antenna in an inverted-V configuration, for instance, is likely to change the characteristics by an unexpected amount. "450" ohm ladder-line characteristic impedance varies all the way down to 375 ohms for the #14 stranded configuration and velocity factor varies among the different manufacturers and batches of ladder-line.

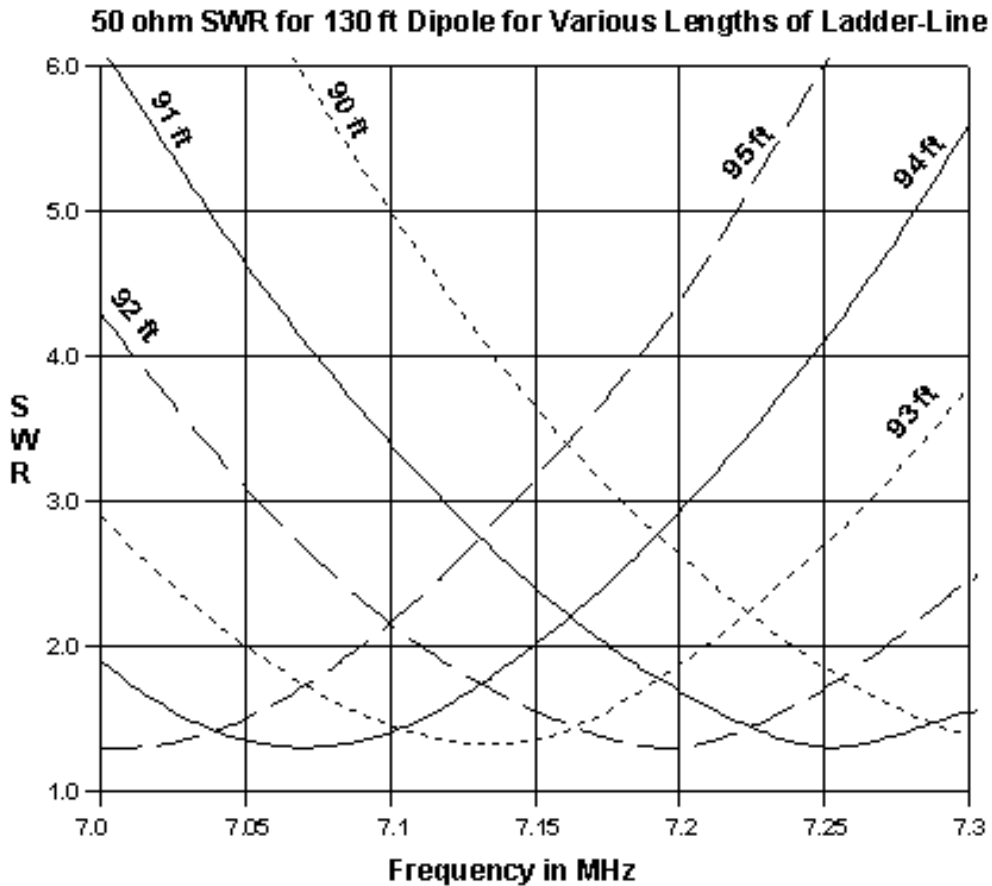

Who says a full-wave dipole is hard to match? Here's what EZNEC predicts will be the 50 ohm SWR across the 40 meter band for W5DXP's No-Tuner All-HF-Band Antenna given the chart lengths of ladder-line. Similar SWRs occur in similar patterns on the other HF bands.

No-Tuner "Shorty" HF-Band Antenna

66 ft. centered dipole 37 ft. in the air

50 ohm SWRs at a current maximum

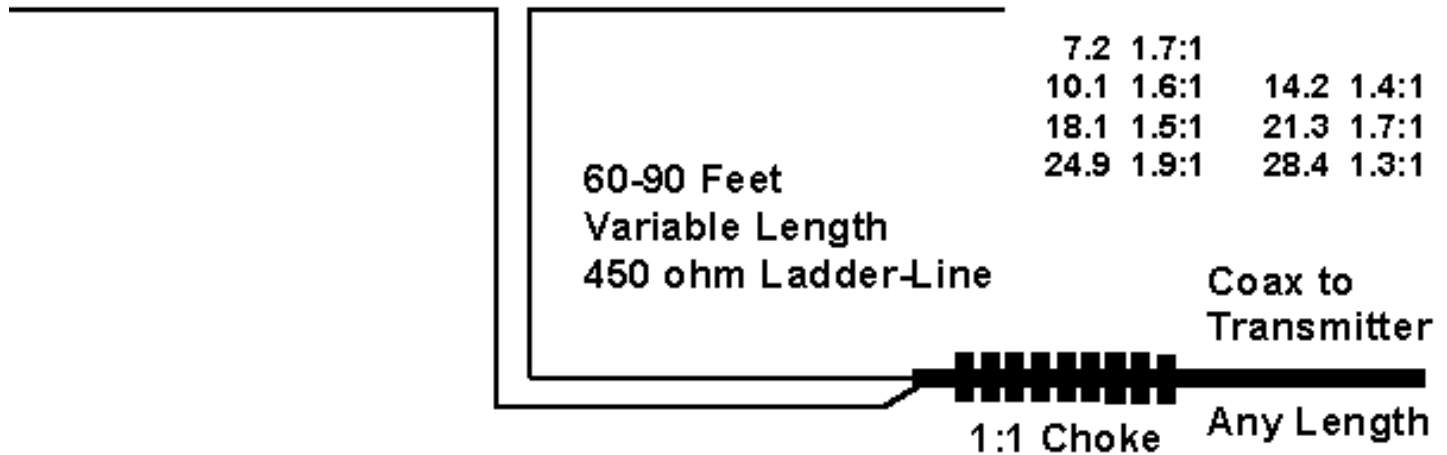

Ferrite beads for the 1:1 choke are available from Amidon Associates
 Ten of the FB-77-5621 beads will work for RG-58
 Fourteen of the FB-77-1024 beads will work for RG-213
 Thirty of the FB-77-6301 beads will work for RG-174 or RG-316 (Teflon)

For those who don't have the space for a 130 foot antenna, here's a "Shorty" version designed to work on all HF ham frequencies above 7 MHz. Like the bigger version, the 50 ohm SWRs predicted by EZNEC are below 2:1 for the bands of interest. This antenna will work on 75 meters at reduced efficiency with a matching network or tuner.

What 50 ohm SWR to expect when feeding at a Current Maximum Point

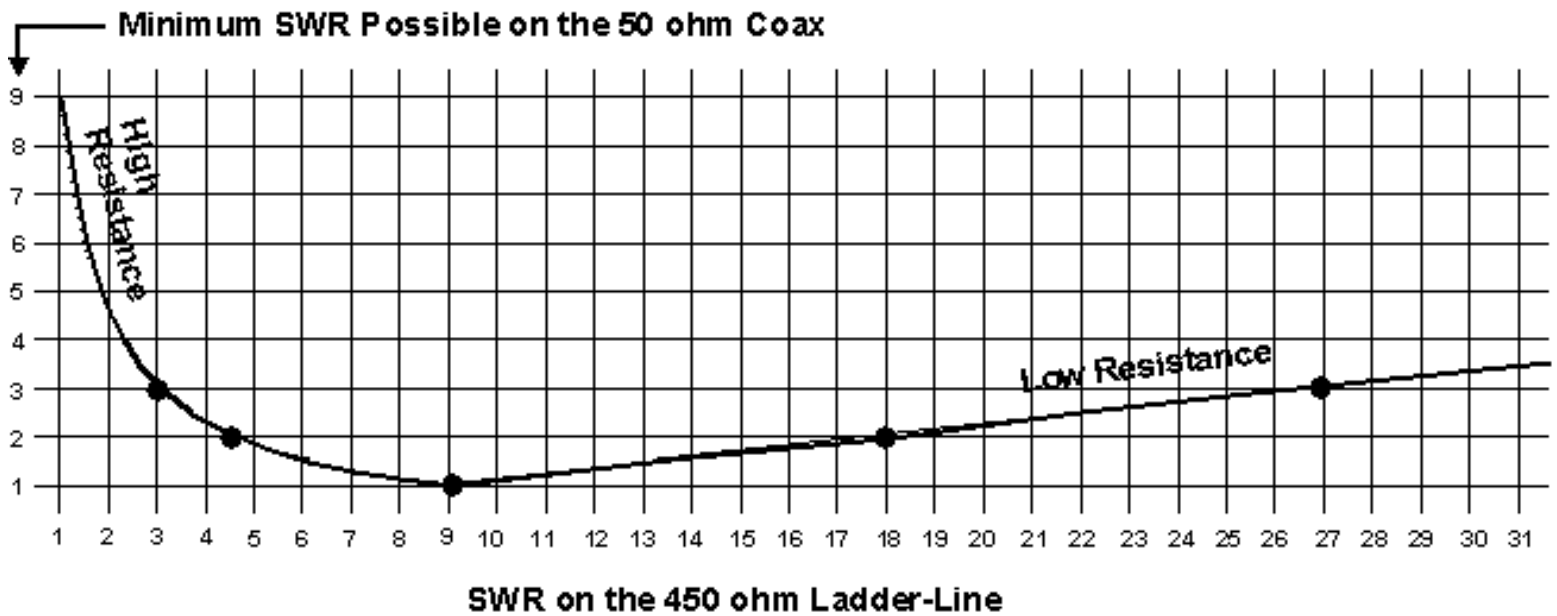

Here is the physics that makes it all possible. Any 450 ohm SWR between 4.5:1 and 18:1 will result in a 50 ohm SWR of less than 2:1 IF the antenna system is fed at a current maximum point. *Moral: Make your center-fed HF antenna system at least a half-wavelength long at your lowest operating frequency and feed it at a current maximum point on the ladder-line.*

Optimum Length For A Matching Section

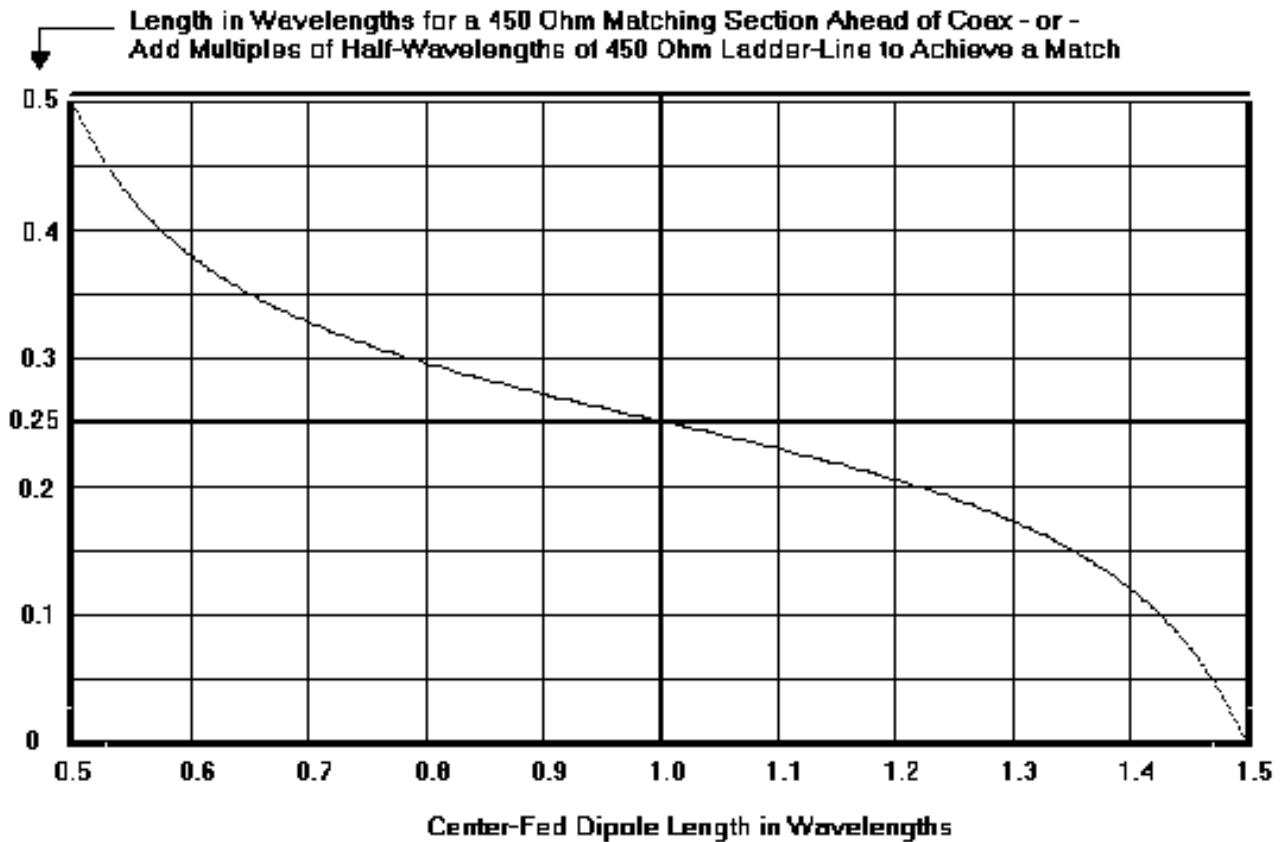

This graph shows the optimum length for a matching section when feeding a center-fed horizontal dipole. The bottom of the chart is normalized to wavelengths so it works for most HF frequencies and most popular lengths of center-fed wire dipoles. The left side of the chart indicates the optimum wavelength for a 450 ohm ladder-line matching section for connection to coax or connection to a multiple of half-wavelengths of 450 ohm ladder-line.

Example: Assume a 102 ft dipole on 7.2 MHz. $102 / (936 / 7.2)$ equals 0.785 wavelengths on 7.2 MHz. Reading the matching section length from the graph yields 0.3 wavelength. A wavelength of 450 ohm ladder-line on 7.2 MHz is $886 / 7.2 = 123$ ft. 0.3 times 123 equals 36.9 ft for the 7.2 MHz matching section. Add $123 / 2 = 61.5$ ft if 36.9 ft is too short for a total of 98.4 ft.

The following BASIC program approximates the optimum feedline lengths given the length of a horizontal dipole and the frequency. It works for both 300 ohm and 450 ohm ladder-line by assuming a velocity factor of 0.8 for the 300 ohm and 0.9 for the 450 ohm. The results are only approximations based on EZNEC and must be fine-tuned to perfection in reality. Cut and paste this program to Notepad and store it in the BASIC directory as lmax.bas

Note: This BASIC program only works for *horizontal* dipoles, not for inverted-V's or any other folded antenna.

```
10 REM This program calculates optimum ladder-line
20 REM lengths given dipole length and frequency
30 CLS
40 INPUT "Enter Frequency in MHz ", freq
50 INPUT "Enter Dipole Length in Feet ", diplenft
60 INPUT "Enter either 450 or 300 for Z0 ", Z0
70 IF Z0 = 450 THEN LLWL = 886
80 IF Z0 = 300 THEN LLWL = 787
90 dipwl = diplenft / (936 / freq)
100 IF dipwl < .5 THEN dipwl = dipwl + 1
110 IF dipwl < 1.5 THEN GOTO 140
120 IF dipwl > 1.5 THEN dipwl = dipwl - 1
130 GOTO 110
140 fedlinwl = .25 - (TAN(2.5 * (dipwl - 1))) / 12.02
150 fedlinft(0) = (LLWL / freq) * fedlinwl
160 FOR i = 1 TO 7
170 fedlinft(i) = fedlinft(0) + i * ((LLWL / 2) / freq)
180 NEXT i
190 PRINT "Imax points (Current Loops) at"
200 FOR i = 0 TO 7: PRINT fedlinft(i), : NEXT i
210 PRINT : PRINT : GOTO 40
220 END
```

Homepage DK7ZB

DK7ZB

Martin Steyer, Die Aue 2, D-37269
Eschwege-Germany

new e-mail: dk7zb@fox28.de

Very important notice: e-mail addresses like CALL@DARC.DE are generated very easily for automatically working spammers. I get about 15-25 spam-mails per day. If I cannot read out my box for some days (QRL, holiday, e.g.) it is possible, that mails will be erased because the box is full or they will be found between the spam-mails, which will be erased too after some days.

If you do not get an answer within some days, please send another e-mail. Please understand my problems and use only my new adress.

This homepage is dedicated to the homebrewing of equipment, especially for building HF- and VHF-Yagi-antennas.

Sorry, a lot of pages in German language, because DK7ZB is writer for some ham-magazines in Germany.

Many *.pdf, *.zip and *.exe-files for download

Commercial use of these designs only with the permission of the author!

Last Update: 07-July-2004

[Disclaimer](#)



New Design and Matching of Yagi-Antennas for HF and VHF/UHF A lot of *.PDF-Files for download

[Enter](#)

 **Radiomuseum** www.Radiomuseum.org
 **> 24'000 Models & > 13'000 Pictures**

Visit the Museum!

The Gain of the Axial-Mode Helix Antenna

by Dr. D.T. Emerson, National Radio Astronomy Observatory ([NRAO++](#)).
Antenna Compendium Volume 4, pp 64-68, 1995, published by the ARRL.

(Copyright on original article is held by the ARRL)

Summary

The axial-mode helix antenna, first described by Kraus in 1947, is probably the most widely used circularly-polarized antenna, either in space or on the ground. There are conflicting claims for the gain of the antenna; most amateur literature, and even many standard textbooks, quote gains which are far too optimistic. More realistic gain relationships are available now in the professional antenna journals, but are not well known in amateur circles.

This article summarizes probably the most extensive numerical modelling calculations on the helical antenna ever performed. NEC-2 was used to model some 10,000 different helical antennas, systematically changing the physical parameters of the antenna and investigating the effect on gain and feed match. For each calculation, between 600 and 1400 segments were used to model an antenna; with frequent checks on the validity of the calculations. Some 3000 hours of networked Sparc workstation compute cycles were used for the study.

The modelling data were compared with results from the professional antenna literature. Reassuringly, the modelling gives results which are intermediate between published experimental and theoretical work. The maximum possible gains are up to 4 or 5 dB lower than those derived from the original Kraus formula for gain. The maximum gain increases much more slowly with increasing antenna length than the simple Kraus formula would predict.

An empirical expression for the maximum possible gain G_{max} of the helical antenna as a function of its length L in wavelengths is:

$$G_{max}(\text{dB}) = 10.25 + 1.22 L - 0.0726 L^2$$

This expression is only valid for lengths L between 2 and 7 wavelengths.

An empirical expression for the turn radius R_{max} at which peak gain occurs as a function of length L in wavelengths is:

$$R_{max} = 0.2025 - 0.0079 L + 0.000515 L^2$$

Again, this is only valid for lengths between 2 and 7 wavelengths.

Gain vs Radius for different Helix Lengths

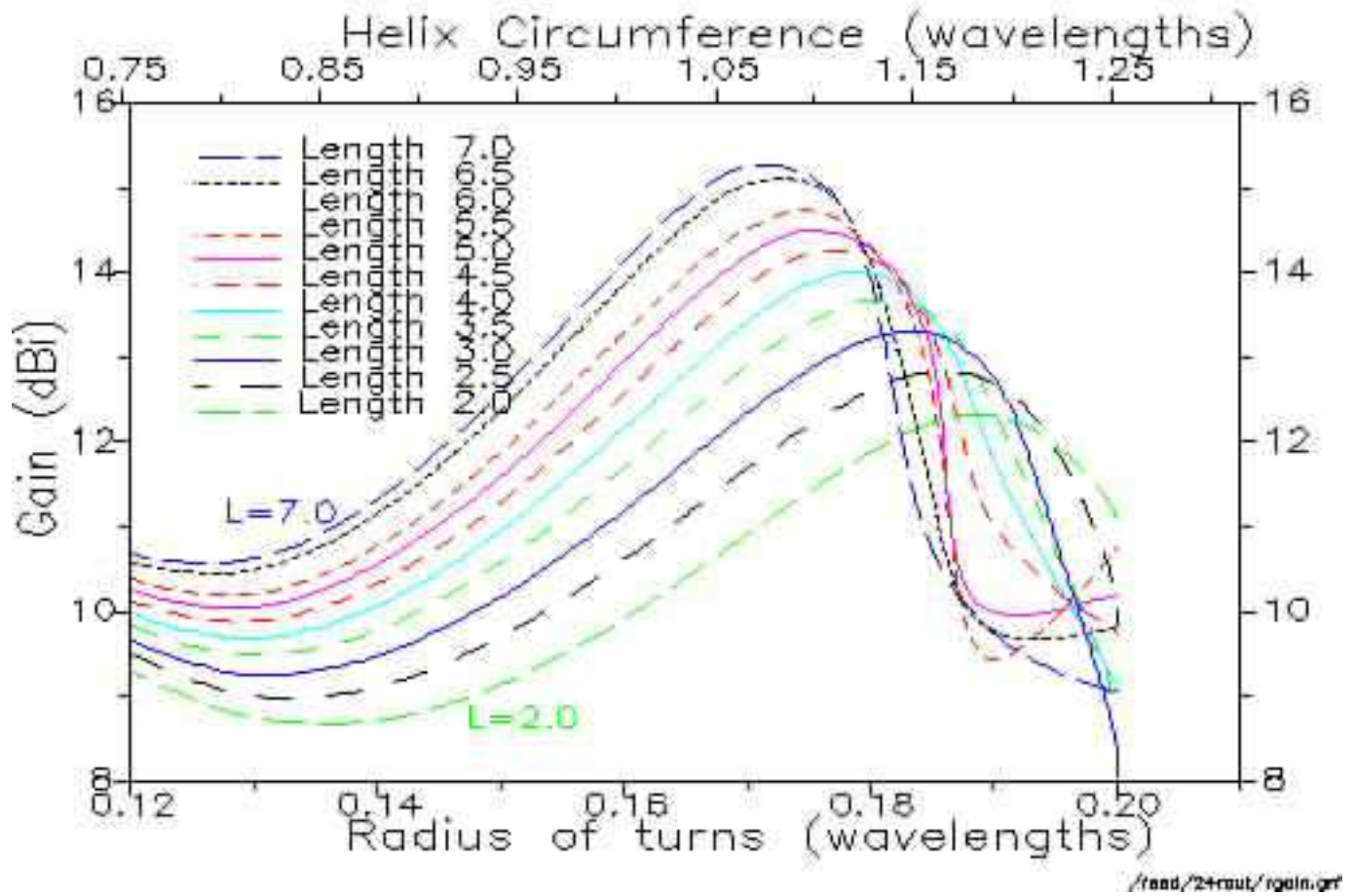

Gain vs length and turn radius, with turn spacing 0.24λ . Note that the radius at which peak gain occurs decreases with antenna length.

Peak Gain (G_{max}) vs Helix Length, and Turn Radius (R_{max}) for Peak Gain

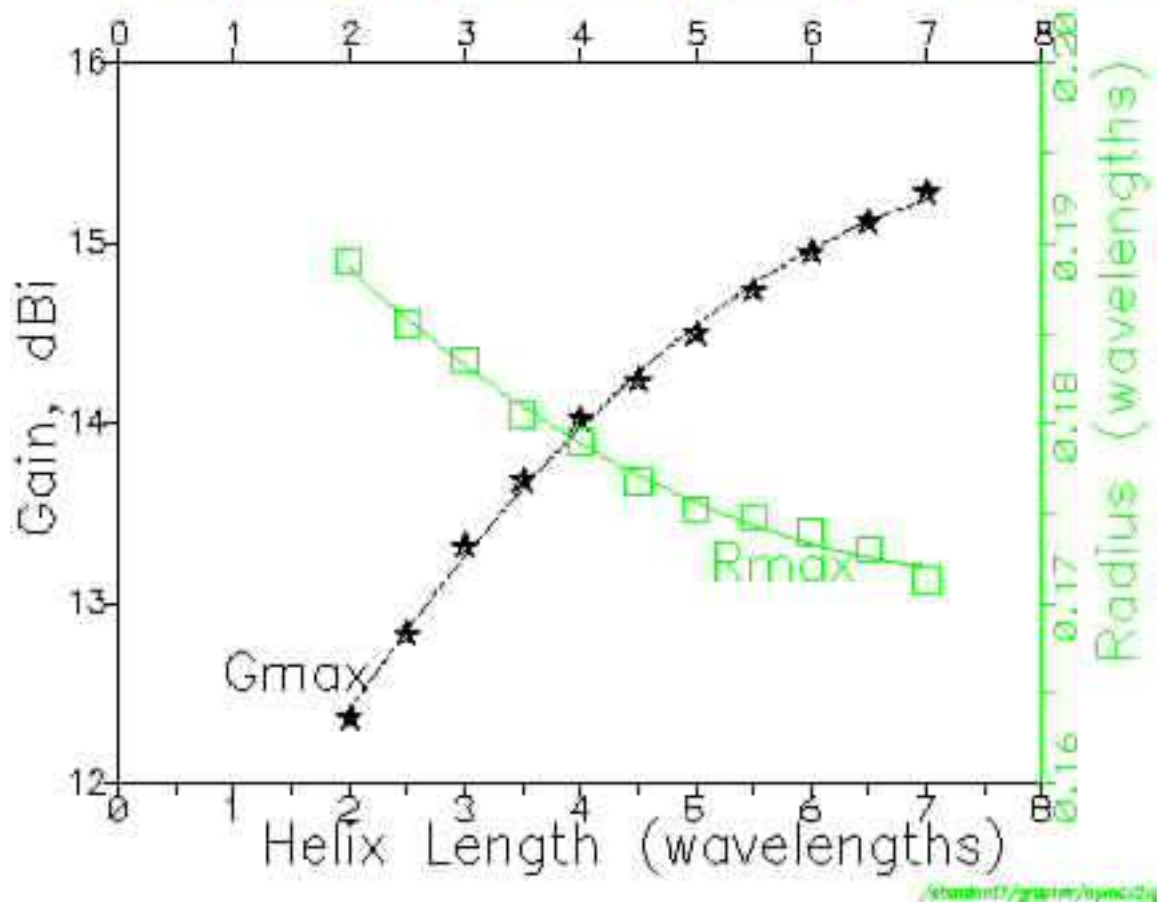

The maximum realizable gain (stars, left axis) as a function of helix length, and the turn radius (squares, right axis) at which peak gain occurs.

Helix gain, vs total length. Theoretical and Experimental Data

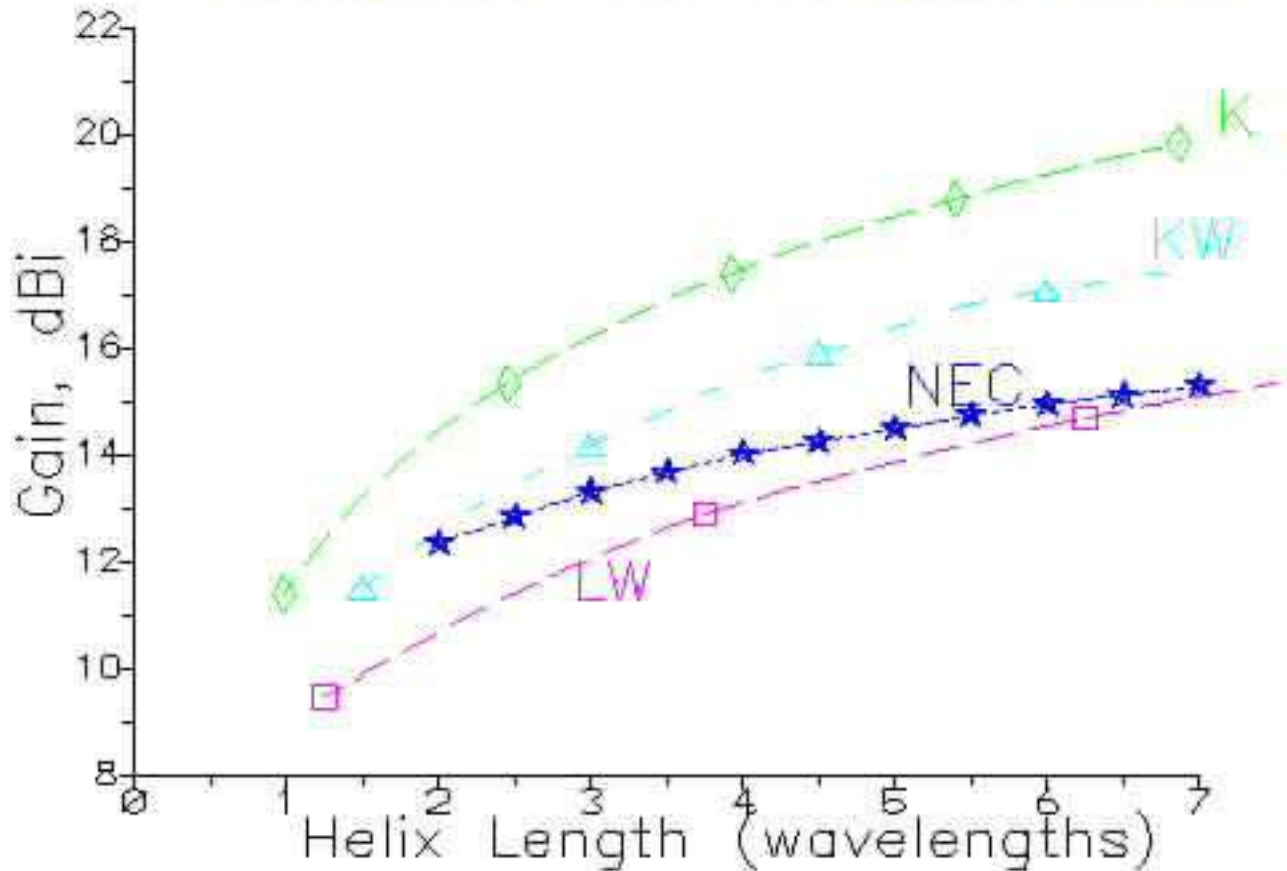

The peak gain of a helix as a function of length, comparing NEC modelling, experiment and theory. K is the gain from the Kraus formula. KW (long dashes) are the measurements of King and Wong. NEC (short dashes) is from the numerical modelling in this article, and LW is from the theory of Lee and Wong. The modelling results are intermediate between theory and measurement.

In summary, this extensive modelling study is in good agreement with theory and measurement from the professional literature, all of which show that the simple Kraus formula for gain of a helix is far too optimistic - by up to 4 or 5 dB.

The modelling shows that, at a given value of turn spacing, the optimum turn radius for peak gain decreases slightly as the helix is made longer. The gain is almost independent of wire diameter, or of the presence of a short feed stub between the ground plane and the start of the helix. The resistance of wire used to construct the helix, even if several times worse than aluminium, has little effect on efficiency. A half-lambda square groundplane is nearly as good as an infinite groundplane. The use of radials, rather than a continuous groundplane, gives a gain penalty of some 3.5 dB.

Please consult the original article for more results, and for literature references. A preprint of a more

detailed article on the gain of the helix antenna, prepared for the professional literature, is available from the author. (Please send e-mail to demerson@nrao.edu.)

++ The [National Radio Astronomy Observatory](#) is a facility of the National Science Foundation, operated under cooperative agreement by Associated Universities, Inc.

[E-mail \(demerson@nrao.edu\)](mailto:demerson@nrao.edu)

Horizontal Half-wave Dipole above a Counterpoise

** Copyright (c) Ralph Holland 1996, Copyright (c) Amateur Radio 1996.*

Introduction

All antennas that are situated close to the ground are affected by that ground to some extent.

The most obvious effect is that the ground forces the antenna's radiation pattern to appear in the half-space above the ground. This is illustrated by comparing the radiation around a monopole fed against ground to that of a dipole in free-space. The monopole has twice the power in the hemisphere above the ground compared with the power in either hemisphere of symmetry for the dipole in free-space. The nature of this reflection of energy above the ground is governed by the polarisation of the antenna and the ground effectiveness. The dielectric constant and conductivity of the ground determines how well the ground acts as a conductor and hence a reflector.

A less obvious effect is that the ground absorbs energy from the antenna; this energy is wasted in the ground's intrinsic resistance (Ref 3).

The placement of an artificial ground, or counterpoise, can decrease the ground losses and enhance the performance of a horizontal antenna. The enhancement can be investigated by performing comparative measurements of the feedpoint resistance or by performing computer simulations.

This article is based on computer simulations using NEC-2 (Ref 1) for antenna systems at 1.825 MHz over average ground with a relative dielectric constant of 13 and conductivity of 5 milli-Seimens per metre [13,5]. The simulations were performed for ideal (lossless) antenna elements with a diameter of 1.22 milli-metres.

Terminology

Displacement is the term used for the distance between the counterpoise (which is the antenna system's lowest element) and the ground. Separation is the term used for the distance between the driven-element and the counterpoise. Displacement, in the regular dipole case, is the distance between the dipole and the ground.

Results

Figure 1 illustrates the efficiency of the horizontal half-wave dipole at various displacements. In general, the efficiency improves as the dipole is raised higher. Note that 100 percent efficiency is not achieved at a quarter wavelength displacement because, even at this height, the ground has introduced some losses into the antenna system.

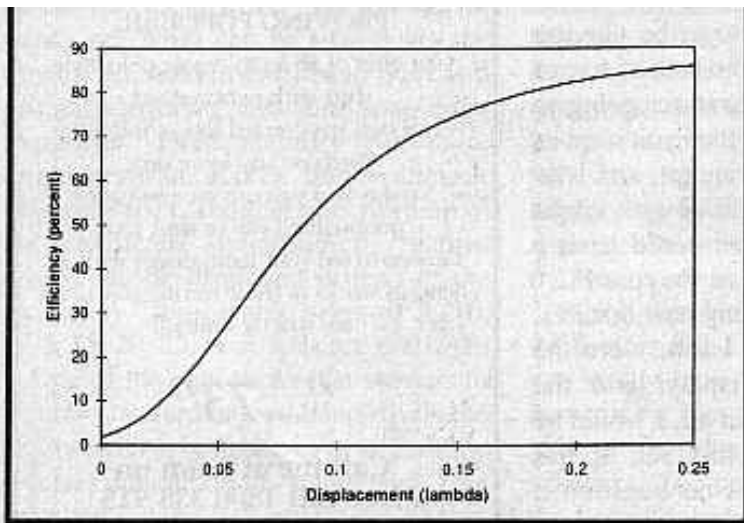

Figure 1 - Efficiency of a half-wave dipole above ground [13,5].

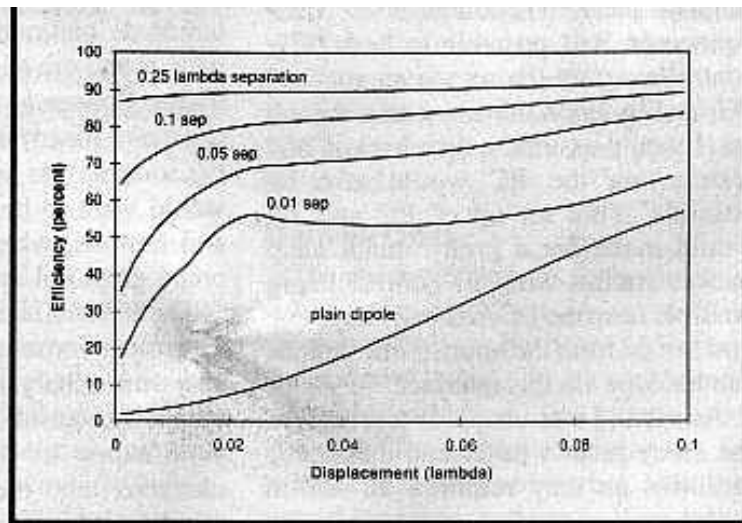

Figure 2 - Efficiency of a half-wave dipole separated from a counterpoise with various displacements above real ground.

Figure 2.0 illustrates the efficiency for various counterpoise systems and a dipole above ground. Notice that there is a knee in the counterpoise curves, which indicates that there is an optimum displacement. Be careful when interpreting the graphs, increasing the separation suffers from the law of diminishing returns; the efficiency of a counterpoise system must be compared with that of a dipole at the same equivalent height, ie. the counterpoise displacement plus the driven element separation. Observe how a counterpoise improves the efficiency of a horizontal antenna system.

Figure 3 shows the radiation pattern of a horizontal dipole displaced 0.07 wavelengths above ground.

Figure 4 shows the radiation pattern of a dipole offset by 0.05 wavelengths above a counterpoise that is displaced 0.02 wavelengths above the ground (same equivalent height as the dipole only system).

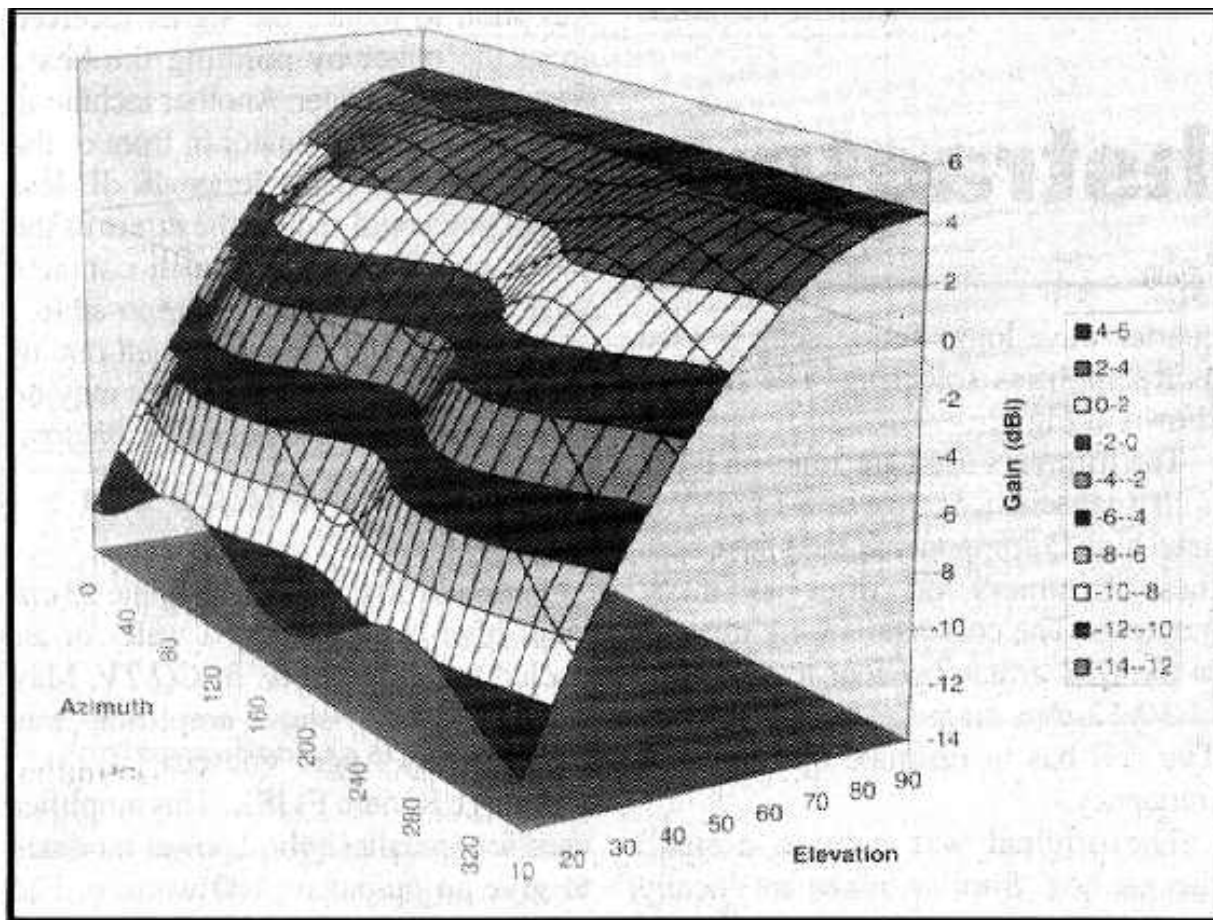

Figure 3 – Radiation pattern from a half-wave horizontal dipole 0.07 wavelengths above ground [13,5].

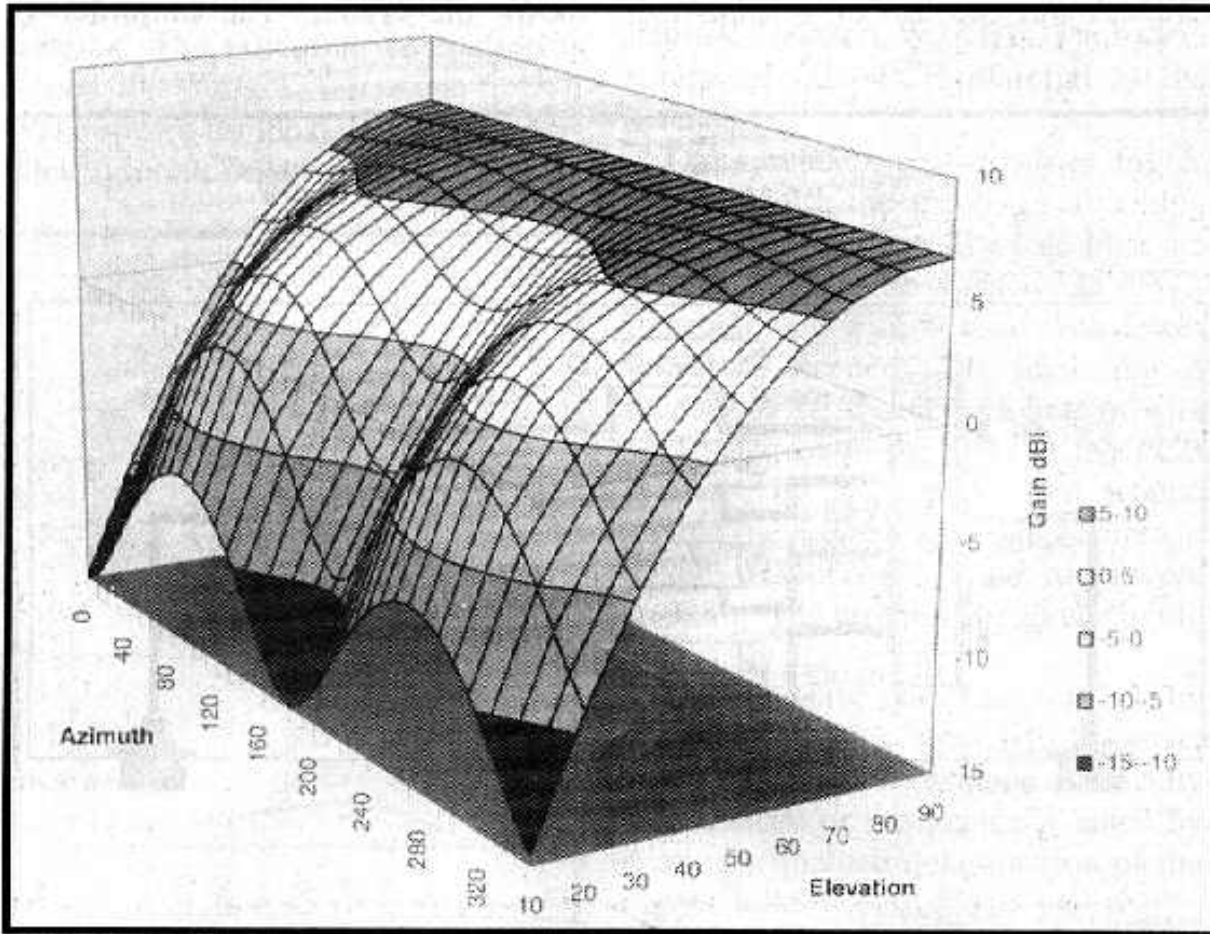

Figure 4 – Radiation pattern from horizontal half-wave dipole above a half-wave counterpoise 0.02 wavelengths above ground [13,5].

The horizontal dipole system has a minimum gain of 0 dBi at 51 degrees elevation, while the counterpoise system has a minimum gain of 0 dBi at about 42 degrees of elevation. Alternatively, antenna gain comparisons at all elevation angles show that the counterpoise gain is greater than the dipole system by 2.53 (0.05 dB). This demonstrates that the counterpoise is a more effective ground system; the counterpoise reflects more energy into the half-space so less is wasted in the intrinsic ground resistance and more is radiated.

Conclusions

The placement of a counterpoise below a horizontal antenna can improve the antenna efficiency by a reasonable amount. The effect under a horizontal antenna is similar to the effect of elevated ground-planes for vertical antennas (Ref 2). You can measure this effect by observing an increase in field strength or by observing the lowering of your feedpoint resistance when adding the counterpoise (Ref 3).

At 160m, with ground parameters [13,5], the effect peaks with counterpoise displacements of about 0.02 wavelengths above the ground.

Increasing the antenna system efficiency with a counterpoise increases the gain at all angles, effectively lowering the effective radiation angles.

References 1.

1. **Computer program NEC-2**, G. J. Bourke, Lawrence Livermore National Laboratory, 1984.
2. **Short Vertical Antennas and Ground Systems**, Ralph Holland, *Amateur Radio*, October 95.
3. **Horizontal Antennas above Real Ground**, Ralph Holland, *Amateur Radio*, October 1996 .

* Terms

This article was first published in Amateur Radio Volume 64 No 11, November 1996 which is the journal of the Wireless Institute of Australia. Both the author and the WIA hold copyright. No reproduction is permitted for commercial purposes without express permission of the copyright holders.

This HTML document was created by [GT_HTML 6.0d](#) 09/03/97 12:55 AM.

Horizontal Antennas above Real Ground

* Copyright (c) Ralph Holland 1996, Copyright (c) Amateur Radio 1996.

Introduction

Antennas are influenced by the effect of the ground and by the type of conductors from which they are constructed. The feedpoint impedance is the summation of the radiator's self impedance, the mutual impedance of its image in the ground, and the loss resistance.

The loss resistance is the summation of the R.F. resistance in the conductor, and the resistance introduced by consumption of power in ground losses and other media close to the antenna. The conductor's resistance is modified by the skin-effect which causes the current to only flow in the outer parts, or skin, of the conductor. The effect causes the resulting resistance to increase in proportion to the square root of the frequency (see Table 1 and Table 2).

Horizontal antennas are subjected to the influence of a broadsize image in the ground. The antenna and its image are in anti-phase, so radiation tends to be cancelled at low angles and the radiation resistance is lowered because the mutual impedance of the image is subtracted from the self-impedance of the driven element.

Modelling

To quantify the effects of locating antennas above real ground, I have once again resorted to computer modelling using NEC-2 (Ref 1). All simulation results have been performed with 1.22mm diameter wire (SWG #18) and assume lossless conductors.

The simulation results are displayed graphically so you can determine the trends and evaluate your own antennas. The soil parameters for each simulation are enclosed in square brackets. For example, [13,5] represents ground with a relative dielectric constant of 13 and conductivity of 5 milli-Siemens / m ($2S = 1/2\text{ohm}$, while $4S = 1/4\text{ ohm}$). The selected values are: [5,1] for poor soil, [13,5] for average clay soil, [20,30.3] for good soil and [80,5000] for sea water, which is very close to perfect.

Table 1 and Table 2 are included so you can evaluate conductor resistance losses due to the skin effect (Ref 2).

Results

Figure 1 shows the effects of various types of grounds on a 1.825 MHz horizontal 0.5 wave dipole between 0.01 and 0.25 wavelengths above the ground. Note how over poorer soils the feedpoint impedance is dramatically higher than the resistance for perfect ground. Notice how the feedpoint resistance for a horizontal antenna becomes very low as the antenna approaches a perfect earth. (The feedpoint resistance of a perfect conductor over a perfectly conducting ground is the radiation resistance of the antenna.)

Figure 2 illustrates the overall antenna efficiency; a measure of how much power is radiated over the hemisphere, compared to power fed into the antenna (the missing power is absorbed by the ground).

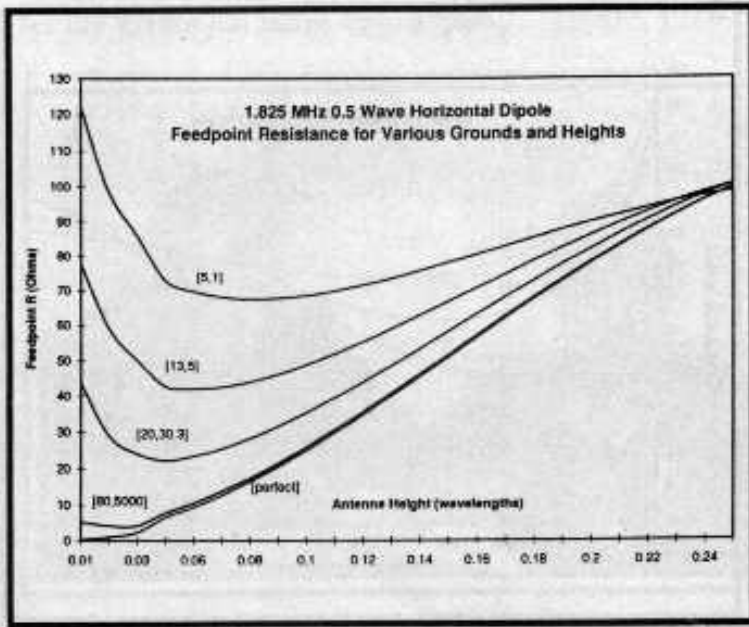

Figure 1

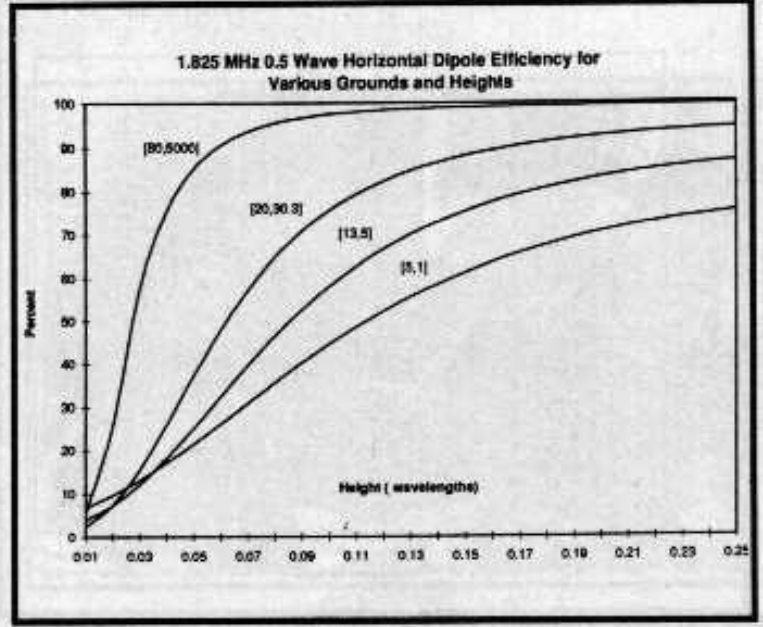

Figure 2

Figure 3 illustrates the effect upon the maximum gain. (However, at 160m, poor ground means the maximum gain is at an elevation of 90 degrees - ie straight up!)

Figures 4, 5, and 6 show the effect upon feedpoint resistance at 3.5 MHz, 7.0 MHz and 14.0 MHz respectively.

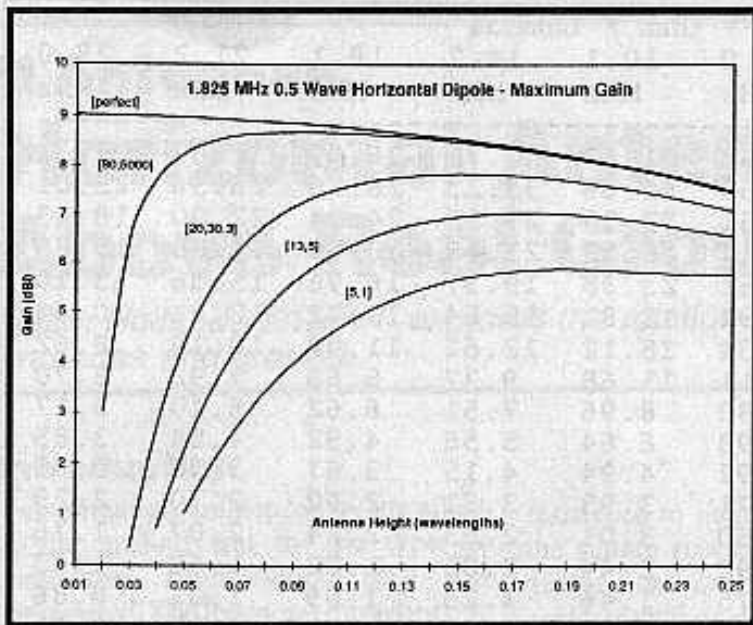

Figure 3

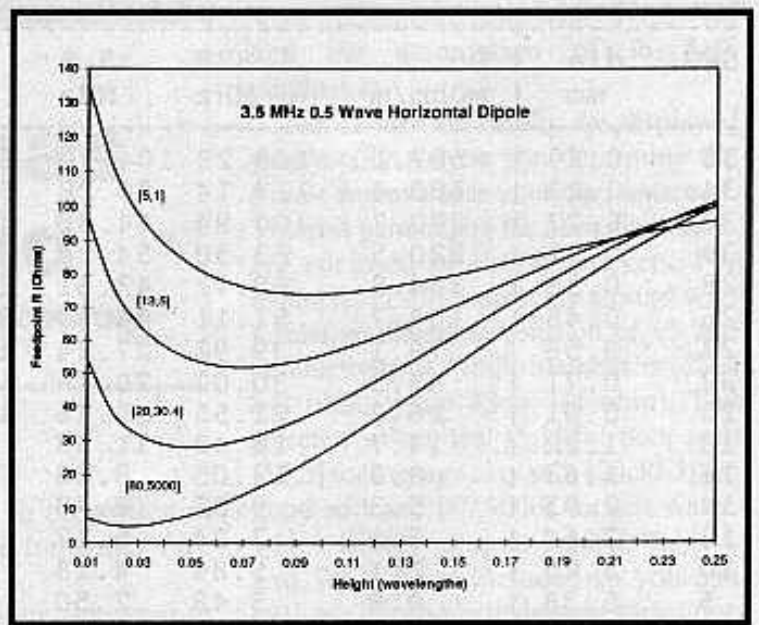

Figure 4

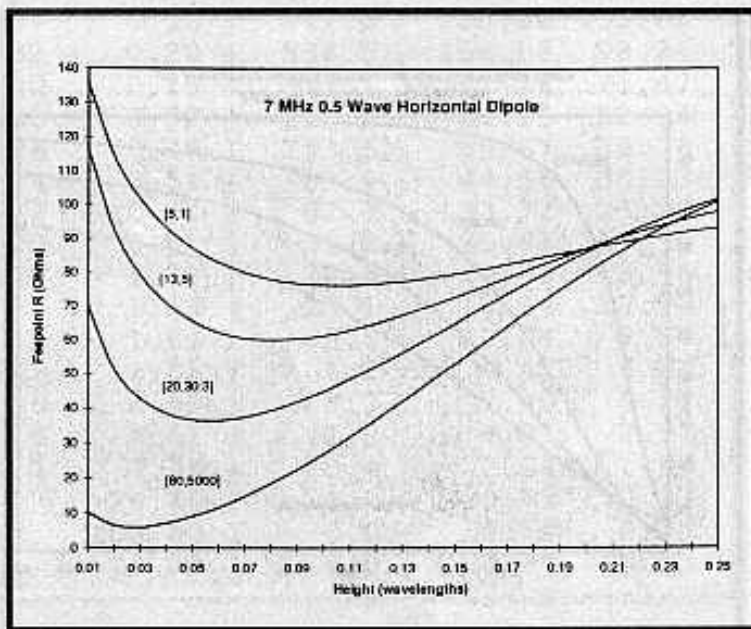

Figure 5

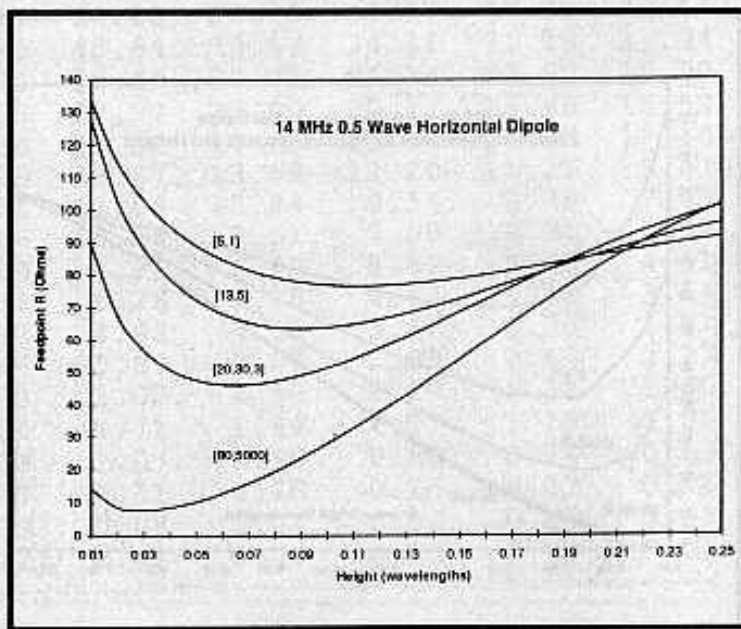

Figure 6

Table 1 and Table 2 give the R.F. resistance of round copper wire at various frequencies. The values are listed in ohms per wavelength. You must halve these values for wires carrying cosinusoidal currents. The resulting value when added to the graphical results accounts for losses in a non-ideal conductor.

Conclusions

The radiation resistance of a horizontal antenna is lowered as the antenna is brought closer to the ground because self and mutual impedances subtract.

As a horizontal antenna approaches lossy media the feedpoint resistance rises due to increasing power losses in the media. You must be wary of this tendency for low antennas to apparently present a good feedpoint resistance.

Poor conductors, or inappropriate conductor sizes, will also introduce loss resistance. This effect is particularly noticeable in cases such as loading coils.

By comparison though, a horizontal radiator has less ground loss than a vertical antenna mounted at the same average height (compare the graphs for horizontals against those for verticals from Ref 3.0).

References

1. Computer program NEC-2, G.J.Bourke, Lawrence Livermore National Laboratory, 1984.
2. Fields and Waves in Communication Electronics, Simon Ramo, John R Whinnery and Theodore Van Duzer. Publisher John Wiley and Sons.
3. Short Vertical Antennas and Ground Systems, Ralph Holland, *Amateur Radio*, October 95.

| | | Ohm / Lambda | | | | | | | | |
|---------|--------|--------------|--------|--------|-------|-------|-------|-------|-------|--|
| B&S dia | Dc. | 1.825 | 3.5 | 7.0 | 10.1 | 14.2 | 18.1 | 21.2 | 29.0 | |
| AWG mm | mOhm/m | MHz | MHz | MHz | MHz | MHz | MHz | MHz | MHz | |
| 36 0.13 | 1356.4 | 329.59 | 195.37 | 114.92 | 89.43 | 71.08 | 60.62 | 54.77 | 44.84 | |
| 34 0.16 | 841.0 | 223.82 | 135.88 | 82.17 | 64.82 | 52.16 | 44.84 | 40.72 | 33.64 | |
| 32 0.20 | 536.5 | 158.03 | 98.24 | 60.95 | 48.64 | 39.54 | 34.21 | 31.19 | 25.94 | |
| 30 0.25 | 337.1 | 112.16 | 71.47 | 45.44 | 36.65 | 30.05 | 26.14 | 23.90 | 19.99 | |

Horizontal Antennas Above Real Ground

| | | | | | | | | | | |
|--------|------|-------|-------|-------|-------|-------|-------|-------|-------|-------|
| 28 | 0.32 | 212.2 | 81.15 | 52.94 | 34.38 | 27.97 | 23.09 | 20.17 | 18.48 | 15.52 |
| 26 | 0.40 | 133.5 | 59.67 | 39.76 | 26.28 | 21.52 | 17.85 | 15.64 | 14.36 | 12.10 |
| 24 | 0.51 | 83.9 | 44.56 | 30.23 | 20.26 | 16.67 | 13.89 | 12.20 | 11.21 | 9.47 |
| 22 | 0.64 | 52.8 | 33.72 | 23.20 | 15.71 | 12.98 | 10.84 | 9.54 | 8.78 | 7.43 |
| 20 | 0.81 | 33.2 | 25.82 | 17.96 | 12.26 | 10.16 | 8.51 | 7.50 | 6.91 | 5.85 |
| 18 | 1.02 | 20.9 | 19.89 | 13.96 | 9.59 | 7.96 | 6.68 | 5.89 | 5.43 | 4.61 |
| 16 | 1.29 | 13.1 | 15.44 | 10.90 | 7.52 | 6.26 | 5.26 | 4.64 | 4.28 | 3.64 |
| 14 | 1.63 | 8.3 | 12.04 | 8.54 | 5.92 | 4.93 | 4.15 | 3.66 | 3.38 | 2.87 |
| 12 | 2.05 | 5.2 | 9.42 | 6.71 | 4.66 | 3.89 | 3.27 | 2.89 | 2.67 | 2.27 |
| 10 | 2.59 | 3.3 | 7.40 | 5.28 | 3.68 | 3.07 | 2.59 | 2.29 | 2.11 | 1.80 |
| 5 | 4.62 | 1.0 | 4.07 | 2.92 | 2.04 | 1.71 | 1.44 | 1.27 | 1.18 | 1.00 |
| 1 | 7.35 | 0.4 | 2.54 | 1.83 | 1.28 | 1.07 | 0.90 | 0.80 | 0.74 | 0.63 |
| 2 | 5.40 | 0.0 | 0.73 | 0.53 | 0.37 | 0.31 | 0.26 | 0.23 | 0.21 | 0.18 |
| 100.00 | 0.0 | 0.0 | 0.18 | 0.13 | 0.09 | 0.08 | 0.07 | 0.06 | 0.05 | 0.05 |
| 500.00 | 0.0 | 0.0 | 0.04 | 0.03 | 0.02 | 0.02 | 0.01 | 0.01 | 0.01 | 0.01 |

Table 1 AWG round copper wire resistance.

| | | Ohm / Lambda | | | | | | | | |
|---------|--------|--------------|--------|--------|-------|-------|-------|-------|-------|-------|
| SWG dia | Dc. | 1.825 | 3.5 | 7.0 | 10.1 | 14.2 | 18.1 | 21.2 | 29.0 | |
| mm | mOhm/m | MHz | MHz | MHz | MHz | MHz | MHz | MHz | MHz | |
| 36 | 0.19 | 587.1 | 169.23 | 104.70 | 64.63 | 51.47 | 41.75 | 36.09 | 32.87 | 27.31 |
| 34 | 0.23 | 400.6 | 127.14 | 80.28 | 50.59 | 40.66 | 33.23 | 28.86 | 26.36 | 22.01 |
| 32 | 0.27 | 290.7 | 100.94 | 64.82 | 41.51 | 33.58 | 27.59 | 24.04 | 22.00 | 18.43 |
| 30 | 0.31 | 220.5 | 83.30 | 54.24 | 35.17 | 28.59 | 23.59 | 20.60 | 18.88 | 15.85 |
| 28 | 0.38 | 154.8 | 65.72 | 43.51 | 28.61 | 23.38 | 19.37 | 16.96 | 15.56 | 13.10 |
| 26 | 0.46 | 104.7 | 51.11 | 34.39 | 22.91 | 18.81 | 15.64 | 13.72 | 12.61 | 10.64 |
| 24 | 0.56 | 70.1 | 39.92 | 27.24 | 18.34 | 15.12 | 12.61 | 11.08 | 10.19 | 8.62 |
| 22 | 0.71 | 43.3 | 30.02 | 20.76 | 14.11 | 11.68 | 9.77 | 8.60 | 7.92 | 6.70 |
| 20 | 0.91 | 26.2 | 22.55 | 15.76 | 10.80 | 8.96 | 7.51 | 6.62 | 6.10 | 5.17 |
| 18 | 1.22 | 14.7 | 16.42 | 11.58 | 7.98 | 6.64 | 5.58 | 4.92 | 4.54 | 3.85 |
| 16 | 1.63 | 8.3 | 12.05 | 8.55 | 5.92 | 4.94 | 4.15 | 3.67 | 3.38 | 2.88 |
| 14 | 2.03 | 5.3 | 9.52 | 6.78 | 4.71 | 3.93 | 3.31 | 2.92 | 2.70 | 2.29 |
| 12 | 2.64 | 3.1 | 7.24 | 5.17 | 3.60 | 3.01 | 2.53 | 2.24 | 2.07 | 1.76 |
| 10 | 3.25 | 2.1 | 5.84 | 4.18 | 2.92 | 2.44 | 2.05 | 1.82 | 1.68 | 1.43 |
| 5 | 5.38 | 0.8 | 3.48 | 2.50 | 1.75 | 1.46 | 1.23 | 1.09 | 1.01 | 0.86 |
| 1 | 7.62 | 0.4 | 2.45 | 1.76 | 1.23 | 1.03 | 0.87 | 0.77 | 0.71 | 0.61 |

Table 2 SWG round copper wire resistance

* Terms

This article was first published in Amateur Radio Volume 64 No 10, October 1996 which is the journal of the Wireless Institute of Australia. Both the author and the WIA hold copyright. No reproduction is permitted for commercial purposes without express permission of the copyright holders.

(from url www.arising.com.au.)

This HTML document was translated from Microsoft Word format by [GT HTML 6.0d](#) 09/03/97 1:19 AM.

W2IK's "[EMERGENCY COMMUNICATIONS GUIDE](#)" to order disc send \$5.00 to: Robert Hejl. PO Box 6731, San

Antonio, TX 78209 "A unique 125 page ham radio emergency course."

CHECK 7 OF MY OTHER WEBSITES BY CLICKING ON EACH TITLE:

[1- HAM RADIO 4 KIDS](#) [2-REAL HAM RADIO](#) [3-"IK-STIC 2"](#)

[4-W2IK's HAM RADIO UNIVERSE](#) [5-HAM RADIO AMONG THE ALLIGATORS](#)

[6-W2IK's BEACON HOME PAGE](#)

[7-HAM RADIO "UNIQUE HEALTH HAZARDS"](#)

15480

HITOMETER

"IK-STIC" by W2IK

(NOT TO BE CONFUSED WITH MY "IK-STIC 2" WHICH IS A MUCH BETTER DESIGN:

CLICK HERE TO BE RE-DIRECTED)

The "IK-STIC" is essentially a **multi-band vertical dipole** antenna which is used in the field for quick set-up and quick band change. Since operation on each band requires antennas of different lengths, I devised a quick method of modifying the length to suit the band you choose to operate. There are no coils or traps. Each dipole band gives 100% radiation, thereby allowing maximum signal at maximum height.

=====

TO BUILD THIS ANTENNA YOU NEED:

[1 - MFJ 1910 33 ft fiberglass mast \(fig.1\) the best choice](#)

click above for link (telescopes down to 3.8 feet !)

OR

[1 - WorldRadio SD-20 TELESCOPING MAST AND 1 PIECE of 12ft. 1 1/2 inch PVC pipe.](#)

(Cheaper than the MFJ purchase, just as good)

(insert SD-20 one foot into PVC and put a stop bolt in the PVC so the pole won't slide down further)

+++++

You might wish to make an additional support (from PVC pipe) to hold the mast upright (or you may skip this and lash the mast to a tree or any **NON-CONDUCTOR**)

[1 - either "CB" or 10 meter dipole antenna](#)

(I bought a "CB" dipole, with center connector.. [Workman Model BS-1](#))

(or you can build one using insulated wire) (see fig. 2)

[1 - roll of STRANDED, insulated connection wire](#)

(Radio Shack size #18-22 100')

[Several Spade Connectors](#) (Home Depot)

(both male and female with **insulated** covering)



BUILDING THE ANTENNA

Take the "cb" or ten meter dipole antenna, which already has a center UHF conector to accept a coax cable, and measure each side from the center. Trim EACH SIDE so that you have 8' 3 1/2" measured from the center. This makes a dipole of 16' 7" ..or a 10 meter dipole. At the ends of each leg, strip

Fig.2 Dipole with spade terminals

off about 1/4" of the insulation and attach a spade connector and crimp it AND solder it in place. see **Figure 2**.



MAKING "BAND ADDERS"

Next, for each band other than 10 meters you wish to operate on, you will need to build "adders" for EACH leg of your ten meter dipole. For example: If you choose to make the dipole operate on 15 meters, the length of a 15 meter dipole is about 22' 2" or 11' 1" on each leg. Since you already have a dipole length of 16' 7", or 8' 3 1/2" on each side, you just need to make two "adders" of 2' 9 1/2". Cut two EQUAL lengths of stranded wire (each 2' 9 1/2") and add the **opposite-type** spade connector, so it mates with the ones you placed on the 10 meter dipole (see **fig 3**) crimp AND solder. You need only add it to ONE end of each "adder". When these wires are added to the 10 meter dipole, you now have a 15 meter dipole. Make other "band adders" using the same method. You see how easy it is to make "adders" for every band you choose to operate. I made them for 5 bands all the way to 40 meters. (see **fig.4**) **DON'T try to skimp by trying to make "adders" on "adders" as it will make your set-up very complicated.**



FIG. 3



FIG. 4

Adder sizes: Make TWO (one for each side) 15 meters: 2' 9 1/2" 20 meters: 8' 2" 40 meters: 24' 6" 17 meters: 4' 7 1/2" note: all approximate lengths.....mid bands



SET UP AND OPERATION

Before you set your antenna up, mark which side of your 10 meter dipole antenna is connected to the CENTER of your coax connector. This side needs to be the highest in the air for best results. Decide which band you wish to operate on and connect your "adders" as needed (one on each side of the dipole). Take a rubber band and use it to hold the end of your "adder" to the TOP of the fully extended mast. Make it a very snug fit as this will hold the antenna as it runs down the mast.



You may wish to use a small amount of tape to hold the antenna to the mast just above the connector point to reduce any additional stress should you tug on the cable. Now add your coax to your antenna allowing it to flow down freely. The lowest end of your antenna wire should now be taped or rubber-banded to the low point on the mast. The antenna will not run to the ground unless you made a 30 or 40 meter antenna or used the Worldradio mast w/pvc. If you did, just tape where it meets the lowest point of the mast and let the additional wire rest on the ground in a straight line. **(Be sure NO ONE comes in contact with the wire during operation.) Note: This is a vertical antenna. It can be used in tight spaces where an inverted "V", etc cannot fit. (such as a limited area campsite) It needs no guys !**

Any time you wish to change bands, just exchange the "adders" for the pair that matches your new band...I find this takes less than 2 minutes. So there you have the "IK-STIC" , all band antenna that weighs less than 5 pounds, needs NO tuner, and you can take it ANYWHERE ! I have worked hundreds of hams in dozens of countries while camping and at special events.

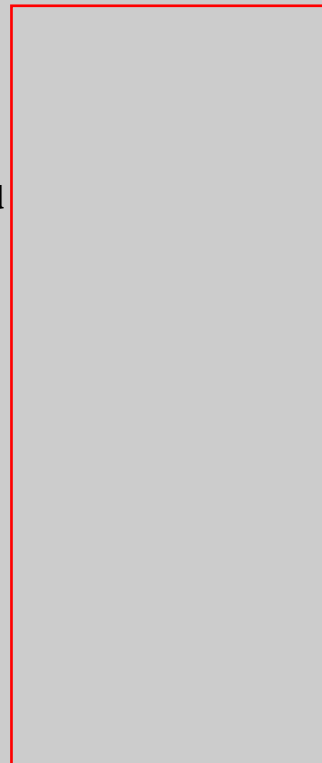

I hope you enjoy it too! Remember: It's called the "IK-STIC" by W2IK !

(the ideas described may not be reproduced without author credit)

+++++

VISIT MY "IK-STIC 2" WEBSITE TO SEE AN EVEN BETTER DESIGN. NO DANGLING WIRES AS THE RADIATING WIRE IS INSIDE THE TELESCOPING MAST. THE ENTIRE LENGTH OF THE ANTENNA IS 25 FEET, YET IT WEIGHS LESS THAN 5 POUNDS. CLICK HERE TO BE RE-DIRECTED!!!

IMPORTANT MESSAGE: GO TO MY HOME PAGE FOR THE WORLD TRADE CENTER DISASTER by the ONLY ham at "ground zero" command center for the first 3 days. Things you never read in any ham radio publication. CLICK HERE TO BE RE-DIRECTED

ALSO CHECK: "EMERGENCY COMMUNICATIONS - A LIST OF ESSENTIALS" CLICK HERE TO BE RE-DIRECTED.

page created with [Easy Designer](#)

W2IK's AMATEUR RADIO "EMERGENCY COMMUNICATIONS GUIDE" now available! To order disc, send \$5 (no checks) to: Bob Hejl, PO Box 6731, San Antonio, Texas 78209. Contains information and ideas NEVER published before.

CHECK MY OTHER WEBSITES - CLICK ON EACH TITLE BELOW:

1 - EMERGENCY HAM INFO (WHAT TO BRING BEFORE YOU GO)

2 - HAM RADIO FOR KIDS 3 - THE WTC 9/11 DISASTER

4- REAL HAM RADIO 2

5- W2IK'S COMMUNICATIONS COURSE PREVIEW

6-W2IK BEACON STATION WEBSITE

7-THE AFTERMATH OF WTC 9/11-MY LIFE IN A SHELTER

8-W2IK's BACK PACK ANTENNA 9-HAM RADIO AMONG THE ALLIGATORS

10- ANTENNA CONSTRUCTION/REPAIR (NEW)

11-UNIQUE HAM RADIO HEALTH HAZARDS



W2IK's "IK-STIC 2"

DESIGNED BY BOB HEJL - W2IK
(PUBLISHED IN AUGUST 2004 "WORLDRADIO")

The "IK-STIC 2" is a vertical, all band, antenna that is over 25 feet tall yet weighs under 5 pounds
! Using a tuner it can easily cover the amateur radio HF bands from 40 - 10 Meters. No unsightly wires as the radiating wire is inside the telescoping mast!

5992
HITOMETER

TO CONSTRUCT THIS ANTENNA YOU NEED:

ONE SD-20 Telescoping mast (WorldRadio sells these)

ONE 6 foot section of 1 1/2 inch PVC Pipe

50 feet of 20 or 22 gauge STRANDED, INSULATED Wire

ONE SO-239 Barrel Connector with washers and Nuts

ONE male and female push on connectors (see photos)

TWO Large (6 inch) Hose clamps (see photos)

Electrical Tape, Epoxy, Duct tape and asst. hardware.



ANTENNA CONSTRUCTION

FITTING THE INTERNAL ANTENNA WIRE INSIDE THE TELESCOPING MAST:

Take the SD-20 telescoping mast and remove the bottom cap by unscrewing it. Looking in you will see the sections nested in place. Remove the rubber plug from the next to thinnest section so now all the sections are "open". Carefully take a 21 foot piece of 20 gauge, stranded, insulated wire and tie a very small knot at the end. Take the knotted end and insert it into the smallest section of the telescoping mast and using a straight wire made from a coat hanger, shove the stranded wire into the section as far as it can go. Then take a small amount of epoxy and glue the wire into place so it can't be removed from the top section. SLOWLY telescope out the entire mast, making sure that the wire slides inside easily. When the mast is fully extended you will have almost 20 feet of wire inside. Leave about 5 inches after the mast is fully extended and cut the wire. This will leave a 5 inch "play" to connect the wire at the bottom. Now CAREFULLY drill a small hole in the rubber base of the mast pointing out SIDEWAYS. Epoxy a push on connector into the hole. Solder another 4 inch piece of that same stranded wire onto the connector on the INSIDE. On the bottom cap of the mast, drill a hole that will allow you to half way insert, and tightly secure, that SO-239 barrel connector. Carefully epoxy it on the inside of the cap so it won't loosen. Next, solder the long wire that is in the mast onto the inner part of the SO-239 connector. Solder the wire from the push on terminal to the outer section of the SO-239 connector. Take the cap and give it about 7 COUNTER CLOCK WISE turns so the two wires are twisted. This way, when you screw the cap on, the wires will untwist in the mast. Tighten the end cap, but do not glue it.



WINDING THE PVC COIL SECTION:

Next take 25 feet of that same stranded wire and start to wrap it around the 1 1/2" PVC pipe at a point 14 inches from one end. (This becomes the top end.) **MAKE SURE YOU LEAVE 8 inches of "free wire" before you start the coil wrap.** Slowly wind the wire around the PVC pipe creating a coil, leaving a spacing of 1 1/2 - 2 inches from each turn. As you wind it down the pipe, you may wish to secure it every so often with electrical tape. The winding does not have to be exact, but keep it as evenly spaced as you can. One foot before the bottom, create a tight wrap of the wire, leaving no gaps on the turns. At the end, tape the wire to the PVC pipe. When you are done, wrap the entire coil in electrical tape so the coil stays in place. On the top end, solder a mating end of a push on connector so it can plug into the mast's side connector.

Wrap several turns of Duct Tape to the very top of the PVC mast. This will serve to offset the taper in the telescoping mast when it gets mounted to the PVC pipe. Using two adjustable hose clamps, carefully mount the very bottom of the telescoping mast to the top one foot of the PVC pipe. **DO NOT OVER TIGHTEN.** It takes very little compression to keep the mast in place. When you have done this, you can extend the mast out it's entire 20 foot length. To keep the entire antenna up-right, slip it over a 4 foot section of appropriate thin wall steel tubing that has been pounded in the ground about one foot. The lower coiled section of the antenna on the PVC pipe will then be slightly "ground coupled". This helps with the antenna's operation on 30 and 40 meters. Plug in the lower coil (The PVC pipe) into the male connector on the side of the telescoping mast. The SO-239 connector is where you screw in your coax cable to your radio. Make a few windings of whatever coax you are using at the connector point and tape them tightly together to prevent RF from returning on the coax shield. Connect the other end of the cable to your tuner and you are all set to go !!.

To dis-assemble the antenna, just remove the coax, loosen the hose clamps and take down the mast after unplugging the PVC coil plug. **CAREFULLY** retract the mast and the internal wire should slowly coil down into the masting. **DO NOT FORCE THE SECTIONS.** A few gentle jiggles and a twist or two will do the trick. After several uses it will be easier to retract the sections as the internal wire will have "memorized" how to coil up. You can even store the telescoping mast in the PVC pipe by making a small slot at the bottom of the PVC tube to accommodate the connector that is on the side of the telescoping mast. The antenna is very simple, light and works well when tuned properly. My first contact was on 15 meters when I spoke to *Siberia*. I have used it on all the bands it covers and have also made an adapter so it mounts on the ball hitch of my truck. This is great when you are parked and can't make a hole in the ground. (**NOTE:** If you wish to make an "IK-STIC 2" that covers 160-10 meters with a tuner, use a 7 FOOT PVC PIPE instead of the 6 ft. pvc and coil 35 feet of wire around it using 1 inch spacing between wraps and two feet near the end increase the spacing until you run out of the wire and the end of the coil wrap is four - six inches from the bottom of the PVC pipe. Any longer coil winding that this will make it difficult to tune the antenna on 10 meters.) (Use the rest of the antenna building dimensions as outlined above.)

REMEMBER.... it's called the "IK-STIC 2"

Designed by Bob Hejl - W2IK

This antenna has been used at Field Day operations, Special Events Stations, JOTA Events and County Activations with great results.

IK-STIC2
STORED
IN IT'S
LOWER
COIL
SECTION



**[LISTEN FOR MY W2IK/B BEACON STATION
OPERATING ON 28.242 MHZ. CLICK HERE TO SEE
PICTURES AND INFO ON MY BEACON STATION](#)**



page created with [Easy Designer](#)

RADIO HABANA CUBA

THE EVER-POPULAR INVERTED "L" ANTENNA

*BY ARNIE CORO (CO2KK)
Host of "Dxers Unlimited"*

SEND YOUR COMMENTS, QUESTIONS AND IDEAS DIRECTLY TO ME AT:
arnie@radiohc.org

Ever wanted to install a shortwave receiving antenna FAST?!!! Then I am almost sure that you will want to learn more about the "Inverted L" antenna... About the easiest effective skywire to build ...

Just two supports... may be two masts, a mast and a tree, a mast and a nearby building... it need not be perfectly horizontal above ground... as a matter of fact if the inverted "L" is installed in a slightly tilted angle it seems to work better.

Although strictly speaking a true inverted L has the downlead connected to one end of the horizontal section... my version calls for connecting the downlead (a single wire) to a point about 20 percent from one end.

The antenna should be connected to your receiver via an antenna tuner with a real wide matching margin. For a 10 to 15 meter horizontal section, strung between two masts of about 5 to 7 meters each, you may expect very nice performance on frequencies extending from about 3 to 30 megahertz.

Using the inverted "L" for transmitting, does require the installation of a good ground system or a "floating counterpoise", a device coming from the early days of radio that provides an amazing improvement in performance of many antennas... More about the "floating counterpoise" soon right here at this WWW site...

You may want to build your inverted "L" with copper wire of no less than no. 16 gauge.. I prefer to use PVC covered copper wire of no 16 or no 14, same type as used by electricians for home installations.

Overall antenna length is not really critical, but the inverted "L" does need have a

horizontal section of no less than 5 to 7 meters and a vertical section of no less than 3 to 5 meters to work effectively. The most tested version here has a spacing between masts of 20 meters, a height above average terrain of no less than 5 meters and I used a single wire floating counterpoise, installed below the horizontal section of the antenna.

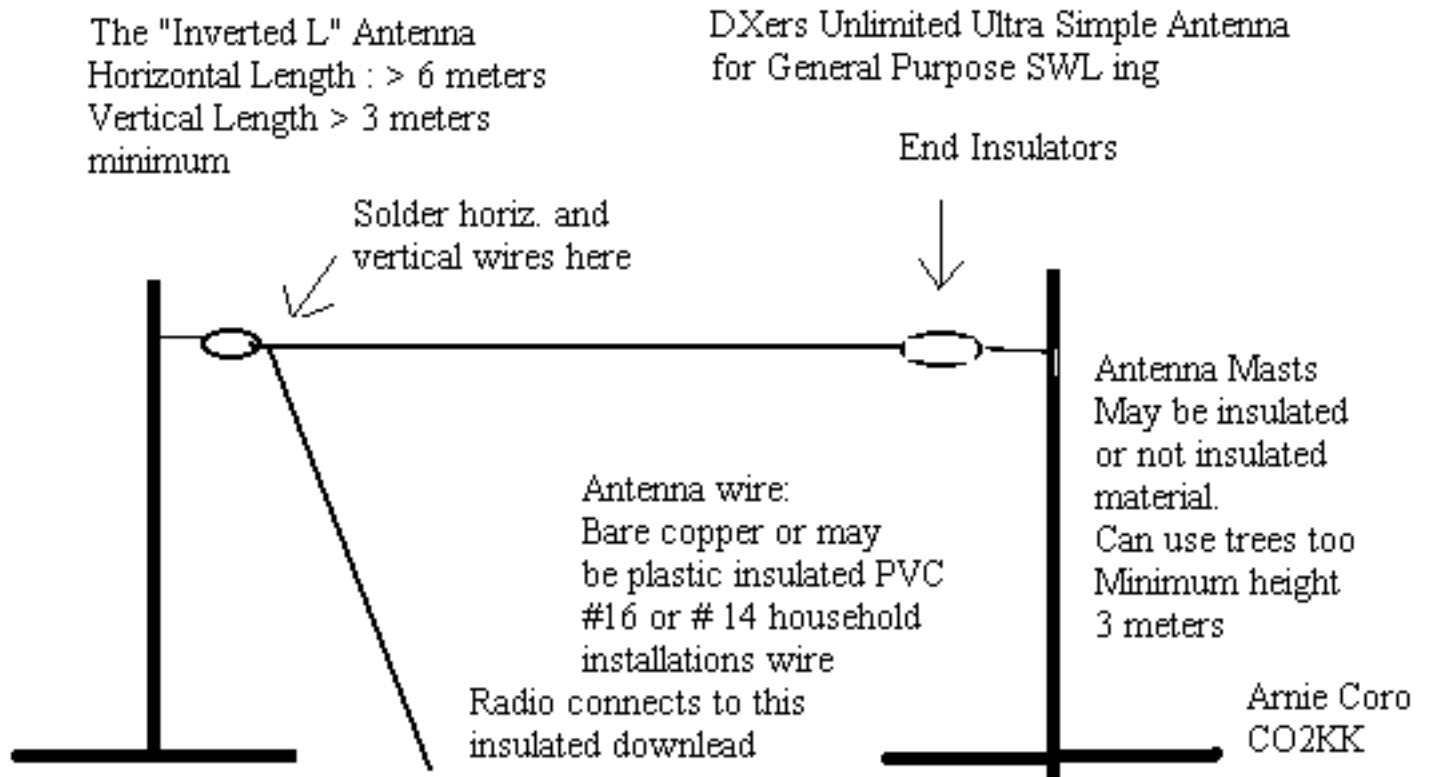

Do remember than in order to obtain optimum performance from this very simple, yet effective, short wave antenna, you do need to install it properly, solder the antenna downlead to the horizontal section, and use an ANTENNA TUNER...

Wish you success with this rather simple antenna project...

Doubts??? Then send a message to arnie@radiohc.org

*Havana, Cuba
25 December, 1997*

[Send e-mail to Arnie Coro](#)

[Back to RHC Homepage](#)

The KGØZP Super Linear-Loaded Inverted V

How do you fit a full length 160 meter antenna into a 40 foot deep yard?
Install the KGØZP Super Linear-Loaded Inverted V, of course!

The Super Linear-Loaded Inverted V allows you to select your two favorite and most used frequencies as band centers, and offers excellent bandwidth as well.

The designers installation centerpoints are set at 1.840 the center of the DX window or calling frequency and 1.875 at an SWR of 1.1-1
The bandspread at 1.5-1 is 20 kc at each center or
40 kc to an SWR of 2-1

The linear-loading section is mounted near enough to the ground that you can easily install or remove precut pigtails using an alligator clip to move the center point temporarily to make that sked, or you can tune the whole 160 meter band with a simple antenna tuner.

The formula for construction is the same as for any dipole 468/fMhz and the design will work equally well on 80 or 40 meters.

Reader Please Note: The photos on this page are greatly compressed to insure quick downloading. The link accompanying each photo will cause the uncompressed full size photo to download.

It would be impossible to show an overall view of the whole antenna system in such a way that you could see the wires.

With that in mind, I have taken a couple of daylight pictures as well as flash night pictures which allowed me to highlight the wires against a black sky.

Lets take a thumbnail look at a daylight view of the Rohn 50 foot push-up pole utilized for this installation.

This is quite a busy photograph, so I will name the items in descending order to help pinpoint the areas relavent to the Super Linear-Loaded Inverted V. [Link to view photo in hi-res!](#)

The white stick at the top extending off the upper edge of the photo is a Diamond Tri-bander, model X3200A, fed with 9913 coax.

Directly below the tri-bander is the first guying ring. This is a dummy ring is used to ground and hold the upper wire of a Wermager type Broadband Sloper. In the full sized photo you can just barely see this wire extending left forward.

The highest of the three actual guying rings (second one down from the top) is at the 40 foot high point on the tower, a pulley is connected to this guying ring and through it is threaded a high quality flagpole rope. This rope can be used to raise and lower the balun for experimenting with different antenna designs, without changing the position of the push-pole.

The Super Linear-Loaded Inverted V, the topic of discussion is connected to this balun. The tension on the wires is so great that it holds the balun outward, the line descending from the bottom of the balun is Super Mini-8 coax. The pull of the Inverted V's two antenna wires is offset by two guywires on the other side of the guying ring. I have a wide yard and could keep the apex slightly wider than 90 degrees.

The next guy ring down is at the 30 foot height point and has nothing more three guy wires.

The lowest guy ring visible in the photograph is at the 20 foot level, and is the feedpoint for the Fan portion of a Wermager type Broadband Sloper originally used on 160 but now cut for 80 meters. I would like to mention again that the upper wire of the Wermager type Broadband Sloper is the wire grounded to the push-pole at the dummy guy ring at the very top. The other end of this wire is tied to the same location as the guy wire coming from the 30 foot guy ring, which places the metal guy wire directly between the driven Fan and

the grounded sloper element of the Wermager type Broadband Dipole.

This photo is a view showing the East outbound leg of the Super Linear-Loaded Inverted V. In the upper left of the photo, you can see the single sloping wire descending from the balun. The two horizontal wires below comprise part of the Linear-Loading section. [Link to view photo in hi-res!](#)

The remaining photo's were taken at night using a flash, then enhanced to make the wires more prominent.



In this first photo, you can easily see that the Linear-Loading section is a good distance away from the push-pole. I used a distance of 5 feet in this installation, but you can reduce this distance to 3 feet if necessary. The vertical spacers are drinking straws, one nested inside the other for greater strength, a nylon tie line is fed through the center of the straws. [Link to view photo in hi-res!](#)

The upper tie off lines are located 1 foot above the standoff mounted to the eave. The lower tie off lines should also be located at or just above the standoff. Original twine used during initial setup is still visible and should have been removed before taking the photo.

The white insulator some 5 feet above the linear loading section is the feedpoint for the Fan portion of the Wermager type Broadband Sloper.



SPECIAL NOTATION: The upper wire and the lower wire of the linear-loading section are connected at this end only. This will be described in greater detail in the construction notes section. [Link to view photo in hi-res!](#)



These last two photos show the East and West outbound ends of the Super Linear-Loaded Inverted V.

If you look closely, you can see the pigtails wrapped around the lower nylon guys.



In the photo on the left of the East outbound end, the wire from the balun down to the insulator is not visible. The upper guy wire from the insulator is metal, the lower is nylon. An additional twisted wire above the



insulator is used to lift the linear loading section slightly higher than the existing guy mount allows, I did this only because I had something above each outbound end to tie to. [Link to view left photo in hi-res!](#)

The right photo shows slightly greater detail and the antenna wire from the balun is clearly visible. There are no electrical connections at the outbound end of the linear-loading section. [Link to view right photo in hi-res!](#)

Again, if you look closely, you can see the pigtail extension wrapped around the lower nylon guy.

Construction Notes:

The construction of the Super Linear-Loaded Inverted V is quite simple and follows the same formula as for a standard dipole. $468/\text{MHz}$ (FourHundredSixtyEight divided by the Frequency in Megahertz give you the total length in feet for a 1/2 wave dipole). In practice you will use two wires, each being 130 feet long. The antenna shown in the photos is made from 14 gauge insulated copper wire. I ran out of insulators and am temporarily using loops made from 1/4 inch nylon cord at the push-pole end of the linear-loading section. If you start with two 130 foot long wires, you do not have to measure the turning or ending points, they will fall in place depending upon the height you install the horizontal portion of the antenna.

The height of the feedpoint can vary considerably, however, the higher the better. If you can only go up 30 or 35 feet, the antenna will still perform almost as well, but you will require a further horizontal distance to work in. With the feedpoint at 40 feet, the sloping elements are roughly 60 feet long at 40 feet away from the push-up pole. Any distance from 40 feet to 80 feet in length seems to make little difference in the performance of this antenna.

A balun is not an absolute necessity, however, if space constraints keep you from obtaining a spread between the sloping wires greater than 90 degrees, then a balun is strongly suggested.

For all practical purposes, installation is the same as for an inverted V, a feed type insulator or balun is assembled with the coax and both of the 130 foot long wires. Connection of the coax is the same as for a standard dipole. The center conductor goes to one wire and the shield to the other wire. The feed insulator or balun is now hoisted to it's permanent position on your push-pole, tower, gable or wherever you are mounting your antenna.

I will describe the finished setup first, then give some quick install tips immediately following.

One side of the antenna is assembled first and will require a minimum of three insulators or you can use nylon mounts by giving the wire a twist to form a loop to connect the nylon rope to.

The antenna wire is brought out across the yard and the end of the wire is passed through an insulator at the outbound end of the antenna. The antenna wire is then brought back toward the push-pole and passed through the second insulator. The second insulator should be installed about 6 feet away from the push-pole temporarily. The wire then passes through a third insulator 6 to 8 inches below the second insulator, and then proceeds back out to the outbound end.

The ideal installation would have the feedpoint 50 feet above ground level and the linear-loading section 20 feet above ground level. In practice, the feedpoint can be as low as 30 feet above ground level and the linear-loading section as low as 10 feet from the ground without affecting performance to drastically. In any case, the linear-loading section should be maintained as close to horizontal as possible.

The idea is to determine at what height you wish to install the horizontal linear-loading section, and then adjust the insulators and distance between the push-pole and inside end of the linear-loading section so that the first insulator and end of the wire are on the same plane. And you'll really love this, give or take 2 or 3 feet on that tail, preferably give a few feet extra for trimming to resonance.

Any non-metal spacer can be used to maintain distance between the elements of the linear-loading section! No need to go overboard here, it's close enough to the ground you can replace the simple item I use in Quick Tips below.

Simple Sketch showing path of antenna wire on one side of balun.

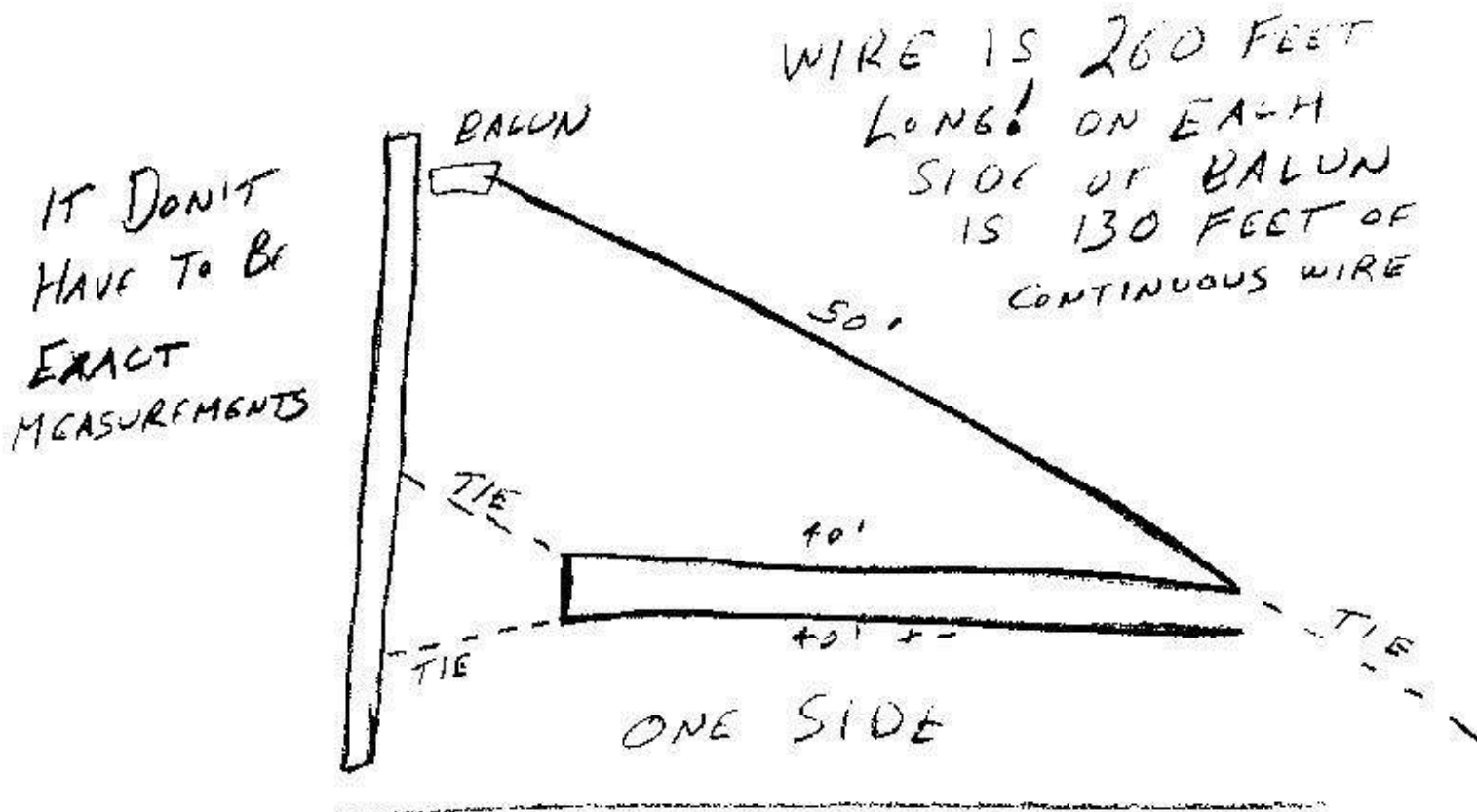

Quick Tips:

Here is how to install this antenna system and have it up and running in well under an hour, excluding push-pole installation of course.

1. Install the wires to your balun and connect the coax, hoist it into position and secure firmly.
2. Pull one wire out taut to your guy mount and secure temporarily.
3. Take the loose end of this same wire and secure it to the push-pole temporarily at the desired final installation height. Note: This end of the wire will be at the other end of the yard when finished.
4. Go back to the outbound end of the antenna, using a stepladder if necessary, pull the wire so that it is taut from the push-pole and lift the wire until it is perfectly horizontal.
5. With a magic marker or piece of tape, mark the sloping wire at the point where the wire from the push-pole crosses the sloping wire. This is where the outbound insulator is to be installed.
6. Install the outbound insulator and tie off (guy) this portion of the antenna to permanent tension.
7. Disconnect the loose end of the wire from the push-pole, pass it through an insulator and bring the loose end out to the outbound end and temporarily connect it to the now secure insulator outbound insulator, leaving 2 to 3 feet of loose pigtail extending through this insulator.
8. Pull the wires from the insulator toward the push-pole until they are in balance at equal lengths from the outbound end, at this bend take the insulator and give it a twist, release the loose pigtail at the outbound end, then secure the push-pole end of the top linear-loading wire and it's insulator to the push-pole at it's permanent position.
9. Install your first spacer (see spacers below) by passing the loose end of the wire through it, bring it up snug to the insulator, install the second insulator and give it a twist to hold it secure. Tie this insulator off to the push-pole as well, trying to keep the spacer vertical.
10. Install additional spacers, one about every five feet, to maintain separation of the upper and lower linear-loading sections.
11. When you reach the outbound end, install your last spacer at the insulator, form a loop in the lower wire for attaching a nylon tie off rope. Pull the rope to tighten the lower linear-loading wire and tie off to the guy mount. Wrap the remaining 2 or 3 feet of pigtail around the nylon rope.
12. Duplicate the above instructions for the other leg of the antenna!

SPACERS:

I take simple drinking straws to use for spacers. But reinforce them to two thicknesses for all the spacers except the inbound spacer near the push pole, this one is three or four thicknesses.

To strengthen a soda straw, you merely slit another soda straw end to end and insert it inside of the whole unslit soda straw.

You only need to pass the unslit whole soda straw over the wire for the inbound spacer, the other two or three slit straws can be added right over the wire and then slid into the whole unslit straw.

Joining the straws to the wires:

I take 24 inch long pieces of braided nylon, like mini-blind sash cord, fold it in half, hold it on one side of the top wire with the loop up and open, then I pass the loose ends of the rope over the wire and through the loop, pull it snug and let the ropes hang until I get all the ties (ropes) installed. By taking a 12 inch long piece of 18 or 20 guage wire and bending a sharp turn at one end, you can use that to slip the ends of the ropes into and slide the soda straw over the wire pulling the rope down through the straw. Place the loose ends of the rope one on each side of the lower wire and tie a square knot, drawing the wire up tight against the soda straws. Don't worry if they are ailt right now, you can true them up later. After the antenna is assembled, tied down nice and snug, and tuned. I will adjust the soda straws to vertical and place a dab of something like plasti-dip-your-grip or dumb gum over the tops of the straws to hid the nylon braid from UV and weather. I usually don't worry about the knot end or lower end of the straw.

Tune-Up:

If I have obstructions in the yard that interfere more with one leg than the other, I will make the shield side of the coax go to that side and the center conductor to the clearer of the legs. Now I tell you!

I normally tune both legs of the antenna first to 1.840 MHz, then I will continue to cut the clearer leg of the antenna all the way down to 1.950 MHz. I will then make a pigtail with an alligator clip on it and retune that leg of the antenna to 1.875 MHz. You can wrap the pigtail around the nylon guy and slide it down at least 6 inches away from the tuned pigtail end and it won't interfere with your upper band setting. In my case, I leave the pigtail connected as 1.875 MHz is one of my popular areas of the band for ragchewing. I may be over 50, but to really fit in up at 1.950, I need another 40 years under my belt, Hi Hi..... You may make other pigtails to center in other areas of the band also. It works on either leg of the antenna!

TTUL - 73+ de Gary - KGØZP

Questions or comments may be e-mailed directly from the home (index) page.

© 1999 Gary V. Deutschmann, Sr. - SCS/RAIAR

Document Revision Date 11/17/99 Applicable To This Page Only

Dipole and Inverted V Antenna Calculator

Enter The Frequency For The Dipole/Vee Antenna Calculation

Use entries like 7.200, 7.2, 144.200, 144.225, etc...

Divided by Freq MHz

Percent smaller for the Inverted Vee

Your dipole's total length is feet

Each leg of the dipole is feet

Your Inverted Vee's total length is feet

Each leg of the Inverted Vee is feet

HAM UNIVERSE

THE DIPOLE AND INVERTED VEE CALCULATOR WITH
DRAWING
TWO CLASSIC ANTENNAS

[BACK TO
ANTENNA
LAB](#)

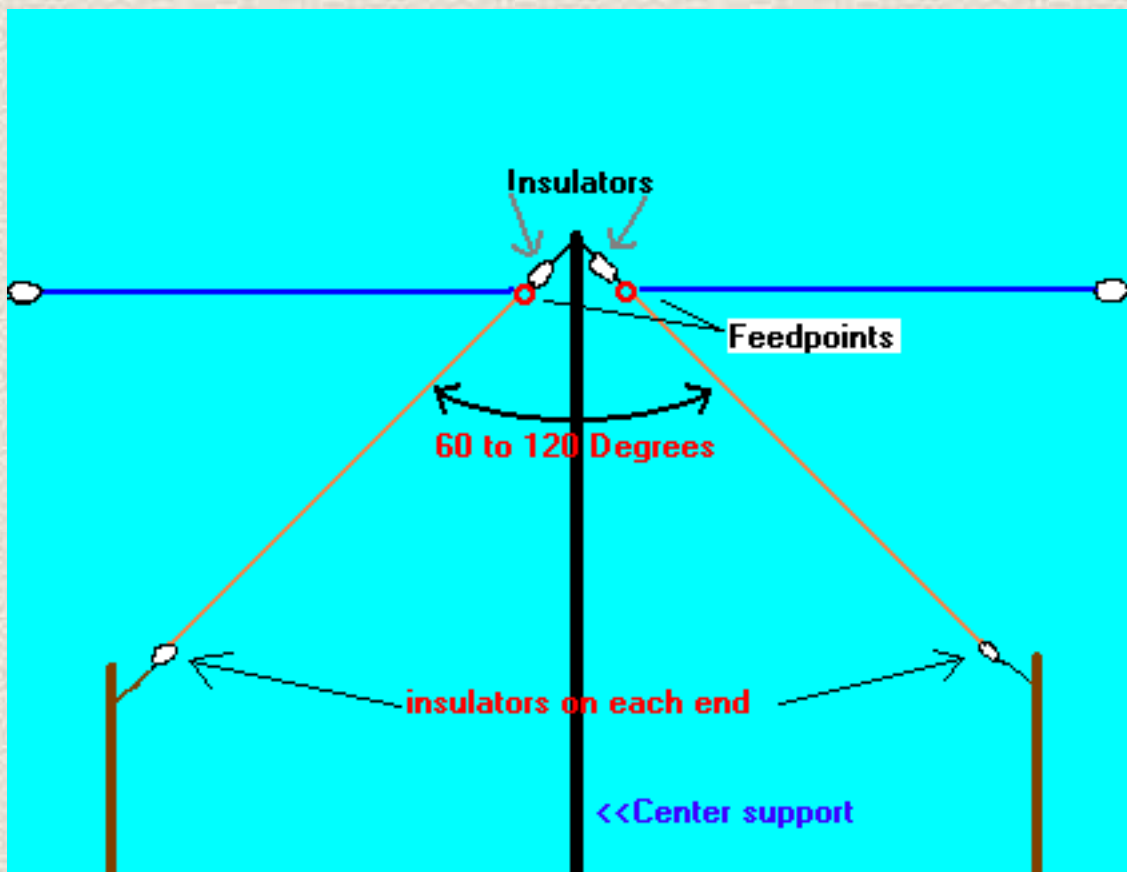

The picture above is a diagram of the old standby CLASSIC antennas....

the **Dipole** and the **Inverted Vee**.

They are shown superimposed on each other in the drawing.

The **Blue line** is the example of a dipole.

The **copper** colored line is the inverted vee configuration.

The inverted vee is just a lazy dipole that can't hold it's arms up and is about 4 to 5% shorter on each half!

Both antennas can be constructed just about anywhere using any type of wire you may have and can be used with 50-75 ohm coax or open wire ladder line and a tuner. The use of an rf choke balun is recommended!

You could use the calculator to build a 75 meter dipole and then calculate an inverted vee for other bands suspended under it from the same support and feed both with the same line to xmtr. A little experimentation may be required for adjustment of the SWR, tuning the 75 meter dipole first for lowest SWR and then the inverted Vee.

EXPERIMENT! EXPERIMENT! EXPERIMENT!

Learn more about the inverted vee compared to the dipole [click here to leave this site to learn more!](#)

[Back to Antenna Lab](#)

Antennas & More for HF antennas

Confused about
length

conversions?

[Download this](#)

[neet length](#)

[converter](#)

[calculator.](#)

[\(It has been](#)

[checked to be](#)

[virus free!\)](#)

[Comes from a](#)

[government](#)

[website!](#)

[Also see](#)

[chart below](#)

Length Conversion Factors

| To convert from | to | multiply by |
|-------------------|-----------------|-------------|
| mile (US Statute) | kilometer (km) | 1.609347 |
| inch (in) | millimeter (mm) | 25.4 * |
| inch (in) | centimeter (cm) | 2.54 * |
| inch (in) | meter (m) | 0.0254 * |
| foot (ft) | meter (m) | 0.3048 * |
| yard (yd) | meter (m) | 0.9144 * |

[More conversion Tables, Charts, Calculators etc](#)

[Metric and Imperial](#)

[Length Conversion](#)

[Calculators](#)

[Charts](#)

[Tables](#)

[More](#)

The Super J-Pole Antenna(Collinear Design)

Below is a Javascript for calculating the lengths of tubing to be used for the construction of a Super J-Pole. The antenna I constructed was made of 1/2" tubing.

Frequency

| | |
|------------------|--------|
| Bottom Section | inches |
| Top Section | inches |
| Matching section | inches |

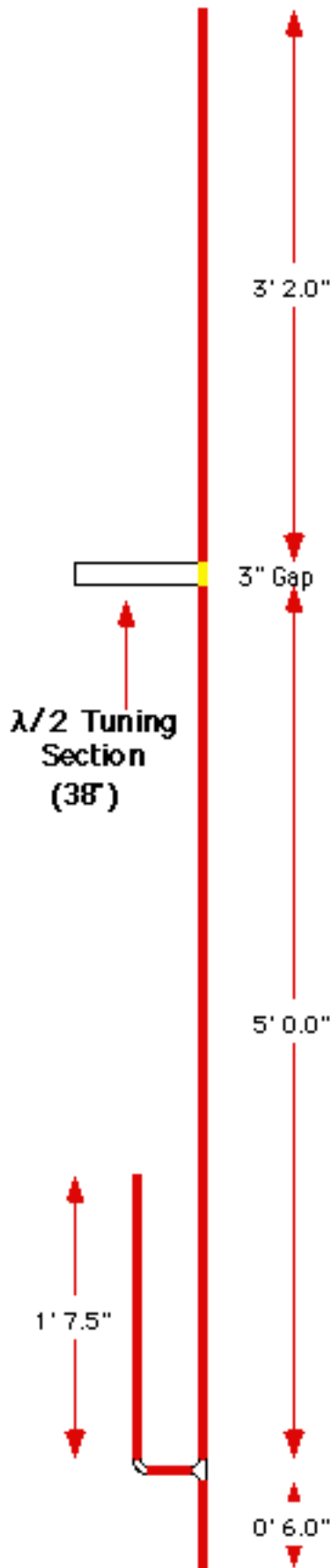

Super 2 Meter J Pole Antenna (a.k.a. Collinear Antenna) with helpful modifications by Aaron Schmitz, KB0YKI

Construction Details:

1. Cut copper to proper lengths.
2. Flux and solder bottom J Pole section.
3. Cut a 38" piece of 12 gauge wire.
4. Solder a 1/2" coupler on the top J pole section and bottom of the top λ/2 length of pipe.
5. Drill a 1/8" hole into each coupler through the pipe.
6. Strip back 3/8" of insulation on wire.
7. Insert wire ends into holes and solder.
8. Bend wire into a 3/4 circle around pipe with a 6" radius.
9. Insert 1/2" X 4" dowel rod into coupler.
10. Completely seal all areas from moisture. Paint it if you would like.
11. Attach coax and have fun!!

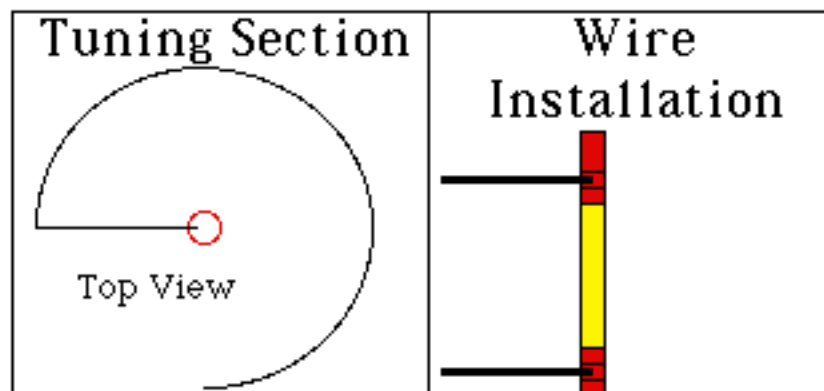

[Return Home](#)

The End-Fed Halfwave Antenna

According to AA5TB

The End-Fed Halfwave Antenna is nothing more than a resonant [dipole](#) antenna that is fed at the high voltage point (high impedance end) instead of in the center, which would be high current point (low impedance). This antenna is as old as radio and is probably best known as the Zepp Antenna named after the airship it was commonly used on, [Zeppelin](#). Since in the early days of radio the wavelengths used were very long the antennas were also long. An end-fed antenna that could be trailed behind the airship was much easier to implement than a center-fed dipole or a 1/4 wavelength antenna that required an extensive ground plane to function properly. Amateur radio operators had found that when an antenna was cut 1/2 wavelength on the lowest frequency of operation it could still be end fed at a voltage loop at all harmonic related frequencies. And since all of the amateur radio frequencies at one time were all harmonically related this made an ideal all-band antenna.

The main reason I like the End-Fed Halfwave Antenna is that it makes an excellent [portable antenna](#) for the field. I often take my [QRP](#) gear out to the field during camping trips and the less antenna gear I need to bring the better. With the End-Fed Halfwave Antenna all I need is a short (or no) feed line to my [coupler](#), a half wavelength of wire, and a bit of rope and I'm all set. The feedpoint usually ends up near the ground and if I can I prefer to run the wire vertically although I've had very good success with it run out horizontally only about 10' up.

When used as a vertical the End-Fed Halfwave Antenna is ideal because like the [dipole](#) antenna, it is self-completing (because it IS a dipole!). That is, it doesn't require a return path or "counterpoise" to properly radiate. This makes it an ideal portable antenna. There are many portable antenna designs in use that really require an extensive ground plane to be efficient, such as the 1/4 monopole or loaded versions of such. Yes, even though the 1/4 monopoles with a few radials will work and often work good, there is no escaping the fact that power is being wasted in the ground and I don't that feel carrying around a bunch of radials is all that much fun.

Now the last statement about this antenna requiring no radials has been debated extensively. In ON4UN's book, "ON4UN's Low-Band DXing" he has modeled the vertical End-Fed Halfwave Antenna and has shown that a radial system with numerous, very long radials will increase the performance of the antenna. He indicates how currents are indeed setup within the ground and losses will occur if radials aren't used. Therefore, he concludes that radials must still be used. I agree with his data but I disagree with his

conclusion. I disagree because the currents that are setup in the ground are maximum at about $1/4$ to $1/3$ wavelength from the base of the antenna, unlike the $1/4$ monopole that has a maximum ground current density right at the base. The other fact is that with the $1/4$ wave antenna, this return current in the ground is required for the antenna to function. For the $1/2$ wave antenna, the ground current is there simply due to the ground being in the [near field](#) of the antenna. The higher you raise the antenna, the less current there will be in the ground. In practice I have found that the vertical End-Fed Halfwave Antenna with no radials outperforms a horizontal dipole at 20' on 20m on short and long paths. Sure, many radials one wavelength long may improve the performance a extra fraction of a dB but if it already works great why go through the trouble during portable operation? Now if you were creating a contest station on your ranch you may want to provide this elaborate ground system.

Others have suggested that one $1/4$ wavelength radial should be used to keep the coupler at a low impedance. This might make you feel better about keeping RF at bay near the coupler but in practice I haven't needed it. In fact, if this does make a difference then current must be flowing in this $1/4$ wavelength of wire and since there is only one wire it will radiate. I have found that this is usually caused by the antenna not really being an electrical halfwave in length. Having a radiating part of your antenna laying on the lossy ground can't be all that great.

Now there are several ways to feed a End-Fed Halfwave Antenna. These methods can be put into two categories:

1. Tuned circuits using lumped components.
2. Transmission line transformers.

The idea is to convert the very high impedance of the antenna (usually around 5k ohms in real life) down to the relatively low impedance (50 ohms) of the transmission line. Now it should be known that if the antenna was infinitely thin, in outer space, and was exactly resonant no energy could be coupled into this antenna using this method (this is what the physicists will tell you). If things were perfect you would have to couple into the antenna just slightly in from the very end of the antenna. In other words, move the feed point from the very end to a foot or two from the end. This would mean that the antenna would be on one side and a very short return wire would be on the other side. This would present a small amount of capacitive coupling from one side of the circuit to the other and RF current would flow. "Luckily", things are never perfect and this situation almost always exists anyway. Therefore, a small return wire may be necessary although there is usually enough stray capacitance from one side of the circuit to the other to satisfy this requirement without any additional return wires.

When using lumped components a parallel circuit is connected to the end of the antenna and tuned to resonance at the operating frequency. This parallel tuned (tank) circuit also

presents a high impedance and easily couples to the antenna. To step the impedance down to 50 ohms you can use either a small winding around the "cold" end of the main coil in the parallel circuit to use as a primary winding or simply use a tap on the main winding just up from the "cold" end of the main coil. The latter approach is essentially an autotransformer and the tap that presents the lowest VSWR at the resonant frequency is the correct one. A [Cushcraft Ringo](#) is another example of this type of antenna. It is essentially using the autotransformer parallel tuned circuit approach but since the frequency is so high the main coil is just one turn of aluminum.

When using a transmission line as a transformer a length of line that is roughly 1/4 electrical wave in length is used. The velocity factor of the line must be taken into account and can vary from one brand or type of transmission line to another. Essentially what we do is use a section of transmission line to transform the high impedance of the antenna (~5000 ohms) down to vicinity of 50 ohms. Then, across the feedpoint we place a short section of shorted transmission (stub) line to finish the transformation. We now have what is best known as a J-Pole antenna. It is often described as a shorted section of a 1/4 wavelength transmission line that is tapped at the 50 ohm point but [Gary E. O'Neil, N3GO](#) has done extensive studies regarding this type of feed and his text on the subject is recommended reading. We usually would want some way to ensure the external currents are not coupled onto the coax with some form of a [balun](#) although most designs do not incorporate one. J-Pole antennas are very common for VHF/UHF operation although most users don't realize that they are using an End-Fed Halfwave Antenna. I have used J-Pole antennas extensively but I believe Gary can describe them much better than I can.

Here are various methods of feeding an End- Fed Halfwave Antenna

(The return connection can be ground or just enough conductor to present a bit of stray capacitance)

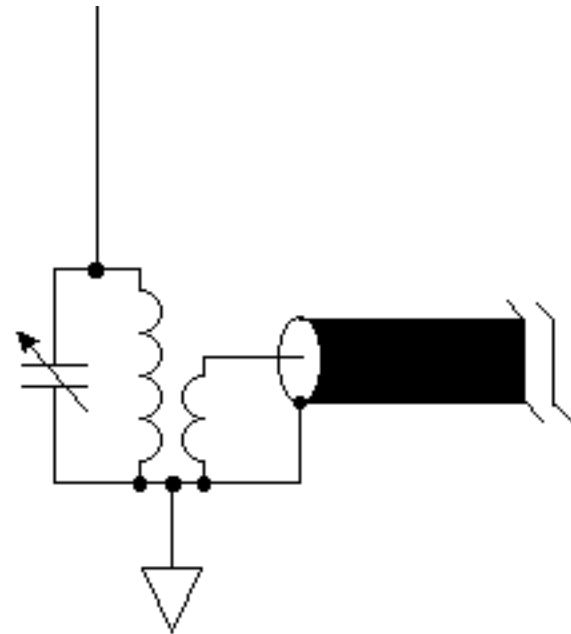
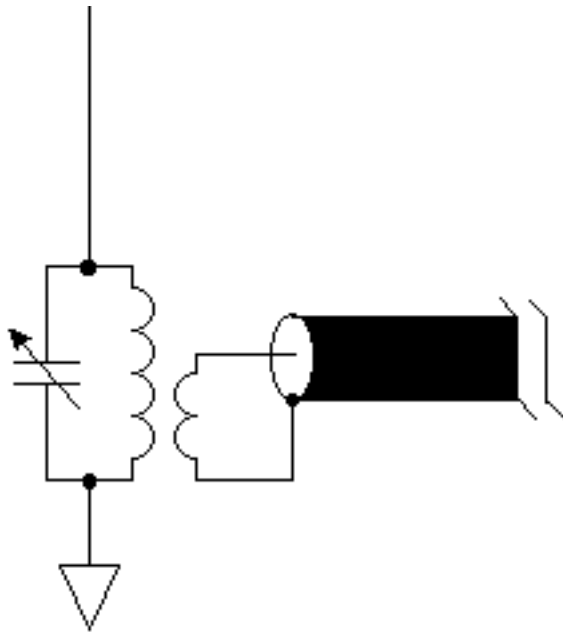

J-POLE

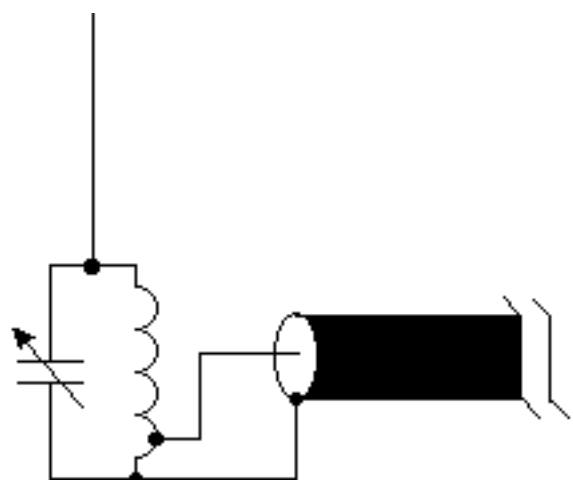

1/4 WAVELENGTH
PARALLEL LINE

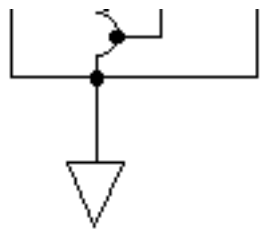

PARALLEL LINE

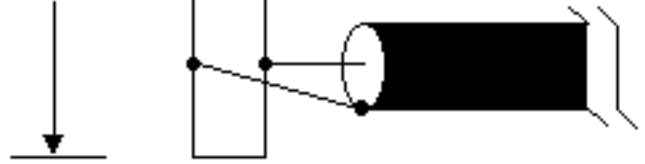

J-POLE

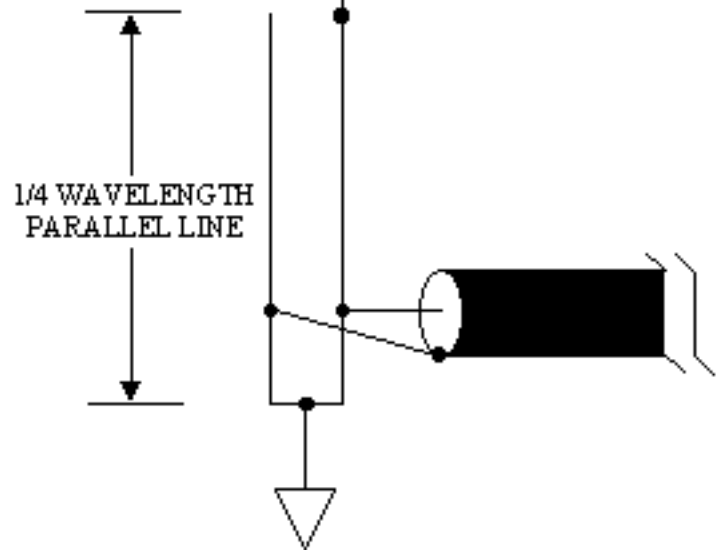

EMPIRICAL RESULTS

During the Lockheed Martin Recreational Association Amateur Radio Club's (whew!) year 2000 Field Day we operated 2A-Battery QRP. We had several wire antennas at our disposal but I would like to give you the EMPIRICAL results of an antenna test that I squeezed in.

On 20m I put up the following two resonant antennas with the following conditions:

1. End-fed vertical halfwave dipole with the bottom up 3' from the ground. A link coupled parallel coil/capacitor circuit for impedance matching to coax. NO RADIALS or GROUND SCREEN.
2. Center-fed (via choke balun) horizontal halfwave dipole up 20' broadside north/south.
3. Same length of RG-58 feedline with losses measured at 1.1dB each.
4. The horizontal dipole was clear of support branches and foliage by several feet.
5. The vertical dipole was clear except that the top couple of feet were thread into the foliage.
6. The antennas were CROSS polarized and separated by at least one halfwave length so mutual coupling should have been minimal.
7. Soil was probably average-good. The ground is normally solid limestone just below the surface but this area probably has top soil sediment from the West Fork of the Trinity River judging by the giant pecan and cedar elm trees.

Now, I have used a horizontal dipole at similiar heights for many years at home and it has always been my a very sure performer, stateside and DX. I didn't expect any better performance without going to a more directional gain antenna or an increase in height. I have used the end-fed halfwave style of antenna for years during my portable excursions and it has always performed well and I have never used radials with it. My expectations were that the vertical dipole would perform better on stations greater then about 2000 miles and that the dipole would perform better on the shorter paths, especially since the peak of its major lobe would be straight up at that height. I was incorrect.

The end-fed halfwave (vertical dipole) routinely outperformed the horizontal dipole on <2000 miles paths by AT LEAST an estimated 6dB except during very short periods of time when the signal would be predominately horizontally polarized. Mysteriously, there

was not as dramatic of a difference on DX signals although the vertical was almost always better.

The dB delta was estimated by S-meter readings on a rig that I had measured to deflect about 1 S-unit every 4dB. The vertical dipole was often better by about 2 S-units so 6dB is probably a conservative figure.

Sproadic-E propagation was very prevalent during that Field Day and on 20m I was working stations at times only 150-200 miles away on skywave yet the end-fed halfwave was still outperforming the horizontal dipole.

I kept looking for something wrong with the horizontal dipole but could find nothing. What could go wrong with a dipole anyway :-) ?

I admit this wasn't a purely scientific test but I believe it was a reasonable A/B test.

Bottom line...

1. A vertical end-fed halfwave dipole outperformed the tried-and-true horizontal dipole at my Field Day site even though I would not have originally suspected that this would be the case.
2. Radials and a ground screen are NOT required but you may use them to gain that extra fraction of a dB ([L.B. Cebik, W4RNL](#)) (QST, July 2000, pg38) if it makes you feel better. There is little current in a ground screen for this antenna until about 1/4 wavelength from the antenna axis, so make your ground screen BIG and carry LOTS of wire. A ground screen may significantly detune a halfwave antenna from resonance since you will be placing a large conductive mass near the high impedance end of the antenna. You may create your own problems. If the antenna is not near a halfwave length, more current will flow near the base of the antenna requiring a better ground screen.
3. I wish I could put one up at my house vertically.

I would like to hear from others who can perform this type of A/B test using skywave signals for the vertical end-fed halfwave dipole versus other field ready antennas. I really did not expect this kind of difference between the horizontal dipole and the vertical end-fed halfwave dipole antenna during portable use and I still would like to have more measurement data.

By the way, we only made about 330 Q's on CW (15/20/40) and 240 Q's on SSB (10/15/20/40) with our solar charged battery operated QRP gear. We could have made more but I spent a lot of CW operating time Elmering some new and potentially new hams about ham radio and this was worth more "points" than the QSO's. I did have one short

rag chew with a station in Tokyo, Japan using the end-fed vertical halfwave.

Related Links

Here are some other ideas on the same type of antenna:

- [From a J to a Zepp](#) - The truth and its consequences - Gary E. O'Neil, Raleigh, N.C. (N3GO)
 - [An End Fed Half Wave Antenna](#), by the late G3YCC
 - [END FED ANTENNA IDEAS FOR FIXED OR PORTABLE](#), by G3WQW
 - [J-POLE ANTENNAS](#) - by Mike Walkington, VK1KCK
 - [Portable End-Fed Halfwave Antenna](#) - by OE3MZC
-

aa5tb@yahoo.com

[BACK HOME](#)

Last updated on May 21, 2004.

On line since July, 1998

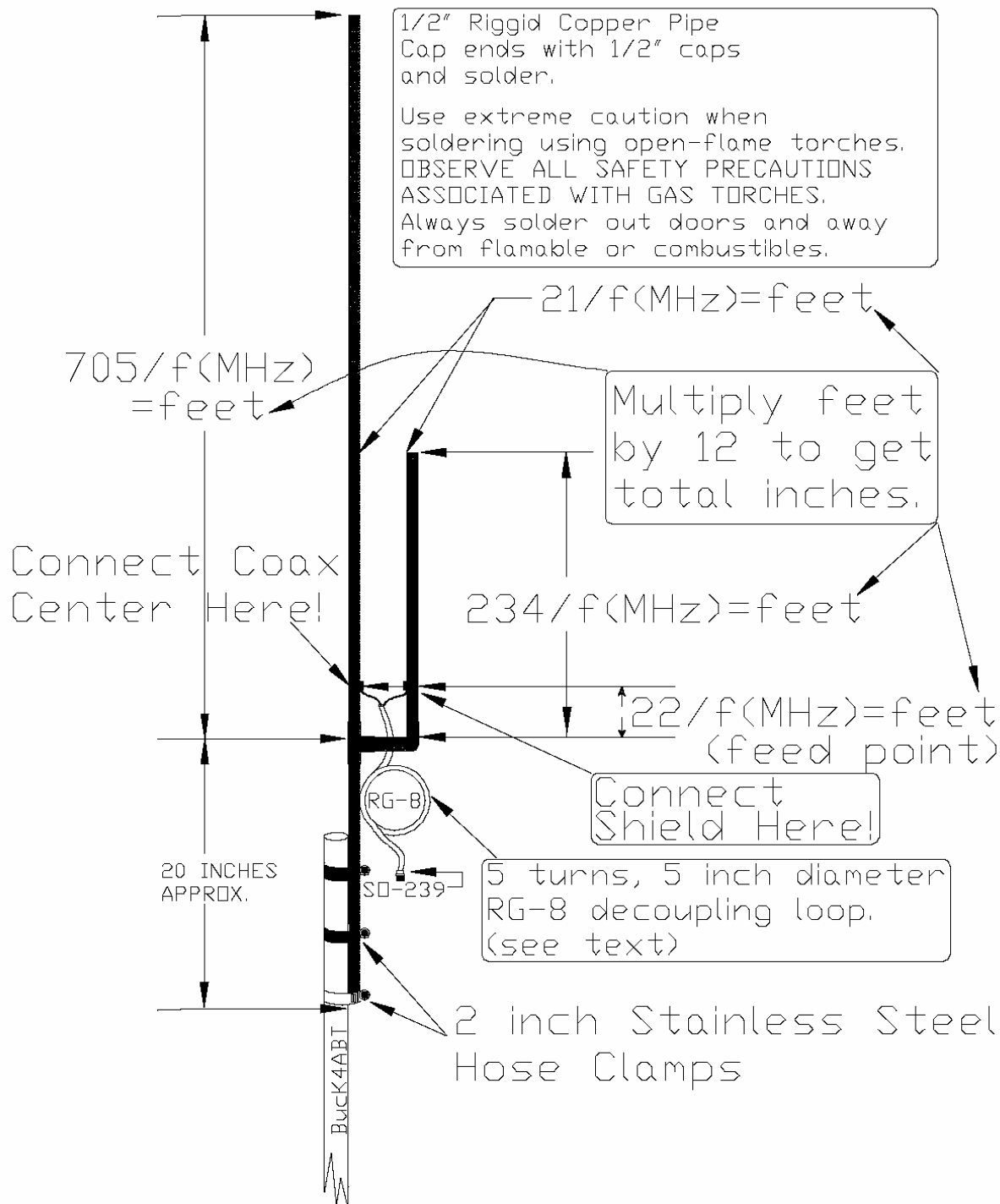

Notice how the decoupling loop is formed from a length of the coax coiled into a 5 turn, 5 inch diameter loop. The coil is then attached it to the mast as shown above. For the final touch, attach an SO-239 (female) coax connector; see text.

A more efficient decoupling transformer is available from:

BUX CommCo, at: www.BUXcommCo.com

AN OUNCE OF LIGHTNING PROTECTION:

The shorted matching stub of the J-pole also appears as if it is a short circuit across the antenna terminals of the connected radio or transceiver. There is also an ounce of protection from static discharges via the antenna port even if you don't make a practice of disconnecting your antenna before a storm. To make life easier and, should you ever need to exchange or replace the antenna, you may wish to do as I have. I made up a section of RG-8 coax. I then dressed and tinned one end and inserted it/them under the feed-point hose clamps. I then coiled a length of the coax into a 5 turn, 5 inch diameter coil (the decoupling loop). I attached it to the (metal) mast as shown in **figure 2**. For the final touch, I fitted the (lower) end with an SO-239 (female) coax connector.

To adjust the Vswr to frequency (145.770 MHz for 2 meters or 51.12 MHz for 6 meters) slide the feed point (hose clamps) up or down as required. You should be able to set the VSWR very close to 1:1 (It is best to make the VSWR setting using at least 25 feet of coax between the SWR meter and the J-pole connector). I have a ten foot section of 1 & 1/4 inch pipe standing in my backyard with three feet of it in the ground. I attach the antenna to the pipe using 2 inch hose clamps. A long length of (not coiled) coax allows me to move away from the antenna at least a wavelength while making the VSWR tests. In short; Do not stand near the antenna while testing VSWR.

Having Fun while saving lives with PacketRadio is what we're all about. For more information and illustrations for the J-pole, visit the PacketRadio Networking home pages on the internet at; <http://www.PacketRadio.com/jpole.htm>

You will find even more PacketRadio information at:

<http://www.PacketRadio.com>

or <http://www.PacketRadio.org>

Visit my personal pages at: <http://www.BUXcommco.com>

You may send Email to me at: k4abt@PacketRadio.com

73 de BucK4ABT

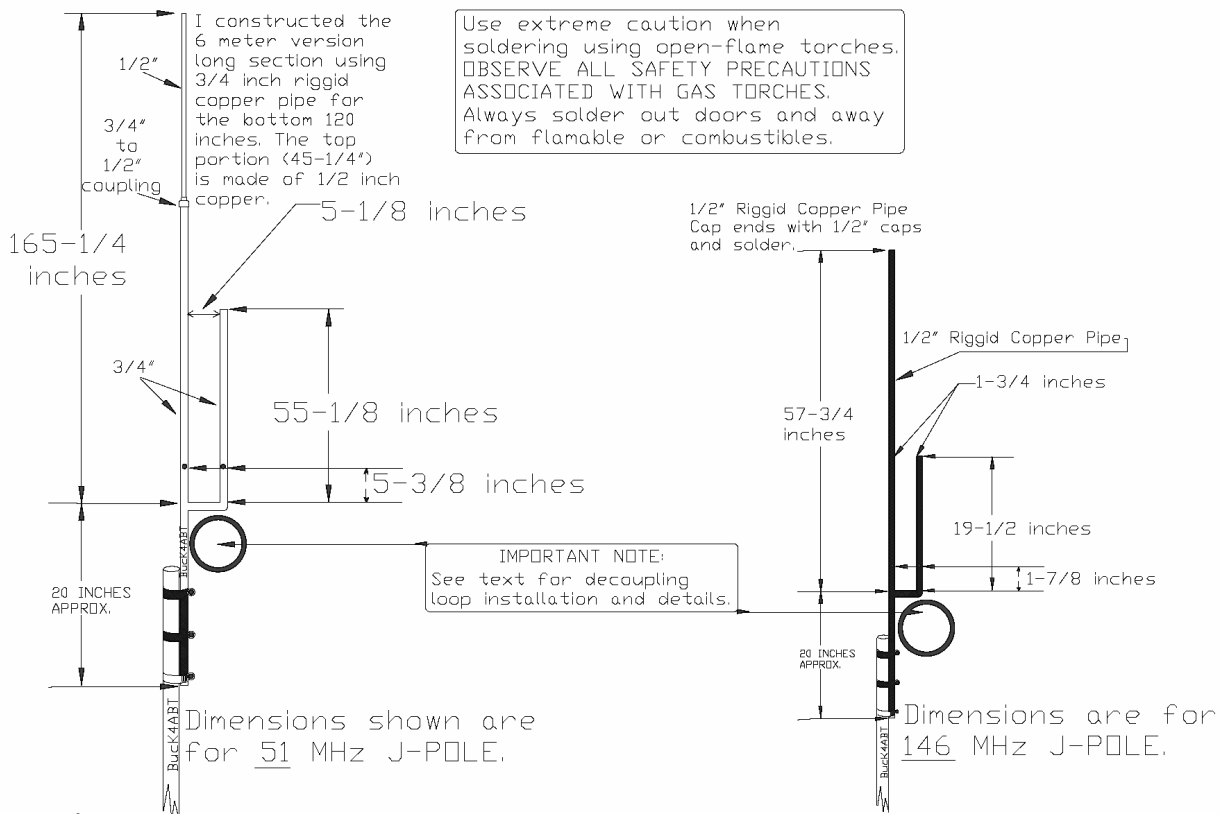

Figure 1a

Figure 1b

Rigid copper water pipe is not as heavy as some might think. Especially when it is only 58 inches long at 2 meters (1a), and when used at 6 meters (1b), a J-pole is about 166 inches long (see text).

To get the correct amount of heat to braze the EMT together, I must use a combination torch/flame that uses oxygen and acetylene gas or a less expensive Benz-O-Matic™ oxygen and MAPP gas.

The latter is available at most Lowe's Building materials for less than 40 dollars (\$39.95). The kit comes with enough welding rods to build one antenna. It also comes with two disposable tanks; one of oxygen and one MAPP. The catch is... one canister of oxygen is not enough to finish the job (one 6 meter J-pole). If you ever consider such a project, make sure that you have at least two canisters of oxygen (\$7.95 each).

In any case, make sure you are out of doors and away from combustible materials while using this type welding system. **PLEASE use extreme caution when working with open flame torches of any kind.**

SOME NOTES ABOUT J-POLES:

There are very good reasons why the J-Pole antenna has become so popular in the past few years. They are economical and easy to build. Now that we have the support data, we are finding they are also rugged enough for the more hostile environments that we have at our node and repeater sites, even below 145 MHz... on our 9600 baud backbone at 51 MHz.

The 6 meter J-poles that I've installed on my nodes are exhibiting over 4 db increase in signal strength above the dipoles that were in use on my 9600 baud (6 meter) nodes.

The most recent antenna I replaced with a J-pole was a 2 meter (see figure 1b), aluminum, base station, commercially built, amateur antenna purported to have more than 3 db gain over a dipole. The J-pole I replaced at node K4ABT-7, alias 007 has increased the average signal at fifteen (15) miles by more than 5 db; ENOUGH SAID!

Our J-pole does not have radials! SO WHAT.. well this is what. Without radials, there are antenna (RF) currents that flow along the outer surface of the coax cable shield that introduce VSWR along its length. This kind of RF action tends to corrupt performance of an antenna that has no radials. Two things can happen; RF may be absorbed and hot-spots along the coax shield will raise the VSWR to an unusable level. To prevent this from happening we add a form of decoupling loop just below the feedpoint of the J-pole (see figure 2).

Our decoupling loop is sometimes mistaken for a matching balun. This is OK as it does perform some of the properties of a balun while altering the flow of RF back onto the coax cable shield. In short, this decoupling loop performs by canceling these effects, and creating a balanced to unbalanced matching transformer. Oh, didn't I say that before... the J-pole is a "balanced" fed antenna... the 50 ohm coax that we use to feed it with is "unbalanced," thus we have another reason for adding the decoupling loop... .. OK Lew, ... it's a balun.

To make our decoupling loop, for the 6 meter J-pole, let's use a length of the same type coax that we use as the feedline. Make a five (5) turn coil (**4 turns for 2 meters**), five (5) inches in diameter and tape it to J-pole mast, below the feed point(s).

We do this near the point where it connects to the antenna (*see figure 2*). In either case, this five turn, five inch diameter coil serves to isolate the feed line's outer conductor from reflected energy (RF) of the antenna radiating element(s).

To set some of you at ease with the feed point question: I did run some tests on the two ways to feed the antenna...e.g. whether it made a difference if the center conductor were connected to the short tuning stub or longer (radiator) section of the J-pole?

Zig or Zag:

Although there is not a big change in VSWR, let it be known! There is a *pronounced (worse)* difference in field intensity when the coax center conductor is attached the short stub of the J-pole; NOT GOOD! Without a lot of fanfare, ... **A RULE; Be sure the coax CENTER conductor is attached to the LONGER SECTION of the J-pole** and the coax shield attaches to the short section,

SOMETHING TO THINK ABOUT:

All the SNO's who support the Packet habit by supporting a Packet node at a high location knows or has experienced what I'm saying. So while I was atop one my Packet node sites an idea hit me... as Steve N4JTH says... I had a brain.. uh.. "wind-breaker."

Most of the antennas that I have been installing at the new node sites are the copper version of the J-POLE. I've removed most of the fiber-glass antennas and ALL the aluminum composition types and models.

I've learned that aluminum was not intended for use at high elevations, especially where ice and wind wreak havoc on them all winter... or until they succumb to the onslaught of this kind of environment.

I tried the next level of durability in the metallic family; copper. Rigid copper water pipe is not as heavy as some might think. Especially when it is only 58 inches long at 2 meters and when used at 6 meters, a J-pole is about 166 inches long. To make the 6 meter version a bit lighter, and still maintain the durability, I make the bottom 120 inches of 3/4 inch rigid copper, and the final (top section, 45 and 1/2 inches), I make of 1/2 inch rigid copper pipe(see figure 1a). We'll discuss this idea further, a bit later. For the record, I find that EMT makes a great J-pole and I find the same characteristics with 1/2" EMT as I find with 1/2" copper.

LET'S TALK ABOUT THE J-POLE:

The J-pole has, for the most part, been a 2 meter and 70 cm antenna. Matter of fact, the first ones were designed and constructed using 300 ohm, television twin lead (or 450 ohm ladder-line, See Lew McCoy WIICP J-pole article, JULY 1994). Not many configurations are supportive of building J-poles for frequencies below 144 MHz or for environments that were demanding of a more rugged type antenna.

A few years ago, I replaced a 6 meter dipole at one of my Packet node sites (3000 feet) with a six meter J-pole (see figure 1a). The first thing I noticed was that instead of just hitting the local 9k6 backbone nodes (those within 50 miles), I am suddenly reaching nodes a hundred miles away.. atop Herndon Mountain in **WEST** Virginia. That is a bit farther than 100 miles. The path is there 95% of the time with the J-pole. The path was there 0% of the time with the old 6 meter dipole.

To help support this data and the use of the more "durable" J-pole, and at frequencies below 145 MHz I received some welcome help at gathering data from **AL (K4ZMC)**:

Al Feldman K4ZMC is a long time friend who has been around Packet radio as long as Packet radio has been around. AL installed a 6 meter (copper) J-pole at his "very hostile environment site" above 4000 feet. The node site K4ZMC-7=**MARS** (NO, not on planet MARS.) is near **Mars** Hill, NC. Actually, the first antenna went to the 9600 baud backbone node on six meters, K4ZMC-9, alias 9600.

When AL installed the J-pole at node 9600, I had the support I needed to begin compiling data on the performance of the J-pole at six meters... and with Als location being such that it is, it gave support for the durability of the ruggedized version.

Since then, I've begun using three-quarter inch (3/4") electrical metal thin-wall conduit, or EMT as it is called, to construct my 6 meter J-poles. EMT, although a bit heavier, is yet stronger and sustains even stronger winds than the copper version does. I used the EMT version at K4ABT-4=9603 atop Poor mountain SW of Roanoke, VA. The reason I did so here is because I've lost several aluminum antennae at this location, and I felt that I needed to make this antenna a very "beefy" version to handle the high winds and heavy ice loads at this site.

The reason I've not said a lot about the EMT version is because the rigid copper water-pipe version can be built (joints soldered, sweated together) using a single canister, Benz-O-Matic™ propane torch.

This is **not** the case with the EMT version. It must be built using brass compound brazing rods. Thus we have a requirement for a hotter melting flame than a propane torch can produce.

Packet Users Notebook

January 1999

Copyright 1998-99
by
Buck Rogers K4ABT

For association and the record, the ZEPP was one of the early antennas used as a "trailing" antenna behind the Zeppelin (Blimps) of the early forties. Later it was fashioned into an antenna for higher frequencies, and in the seventies, and early eighties the name was changed to the "J-pole" to favor its appearance when constructed as a VHF vertical.

In the late fifties or early sixties, I read an article written by Lew McCoy W1ICP. It was about an antenna called a "Zepp." In his reference the antenna resembled one I had raised called a, "windom." After building Lew's version, I liked its performance better.

Thus began a new era for me, experimenting and building the Zepp (J-pole) antennas. I've since built J-pole antennas that operate on ham bands from 14 MHz all the way to 912 MHz. I've build J-poles of everything from 300 ohm TV twin-lead, 450 ohm ladder line, copper rigid water-pipe and even electrical metallic thin-wall conduit.

As I add new nodes to mountaintops here in Virginia, I often come up with another idea for a future **PACKET USER'S NOTEBOOK** article. For me, finding material for a future PacketRadio column is always easy. There is so much to write about, it's as if there is a never ending supply of fodder just over the next ridge.

This time, I think I have come across something that will be of interest not only to the PacketRadio system node operators, but to the voice repeater operators as well. Especially where the Packet node or voice repeater is situated on a mountain top that is a weather hostile location during the winter months.

Adding a new PacketRadio node or voice repeater is only half the battle. When I talk about "hostile environments," I am referring to the torture that our node or repeater antenna is subjected to during the heavy ice loads, snows, winds, and rain. When we are warm and comfortable in our home, the node or repeater site high on that mountain top may be receiving gale-force winds and the antenna may be slowly loading up with a new layer of radial ice.

My friend Chuck and I were atop one of these mountain tops recently and the wind was coming at us like a cold ... no, a frozen knife. The gusts were topping over 50 mph. Now to some, this is not too heavy a wind, but when the wind continues at this clip, hour after hour, the toll on the site usually begins to show signs of wear and tear early on.

The part of our site that takes the worse beating is the antenna. I've tried almost every kind, shape, and model at these sites. At 3000 and 4000 feet, we begin to see damage to the antenna soon enough.

I began thinking; If this is bad here on this lil 3000 foot knob, then ole Fred WB4QOC really has a problem with his node antennas. atop Grandfather mountain, NC (nodes WB4QOC-5 and WB4QOC-6) and Mount Mitchell, NC (nodes WB4QOC-2 and WB4QOC-3). Grandfather mountain is over 5400 feet and Mount Mitchell is the highest point in the USA east of the Mississippi river at 6684 feet.

We do know that winds in excess of 190 mph have been recorded atop Grandfather mountain, but we understand that the equipment used to measure the wind velocity at Mount Mitchell was blown away... pegged out, and burned out the bearings in the anemometer. The first winter that node 6684 was active, he replaced the ISO.. something-another with a stainless-steel whip. It lasted the rest of the season... until it was found in the parking lot of a nearby lodge. It was shot!. Our next try was with a very stubby, quarter inch diameter Wintenna dipole. Dern that thing lasted through the next winter. It must have been a good one... someone climbed up there and took it. We know it was not blown away... wind don't use cable cutters to remove antennas. I think Fred went with a insulated chunk of water-pipe. That is until now.

Design Your Own J-Pole Antenna

another web page supported by:

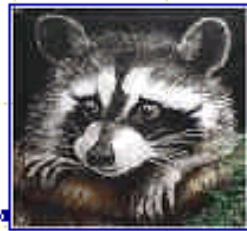

"Home of the RASCAL"

1 BUX Drive; EVINGTON, VA 24550 FAX 434 525 7818

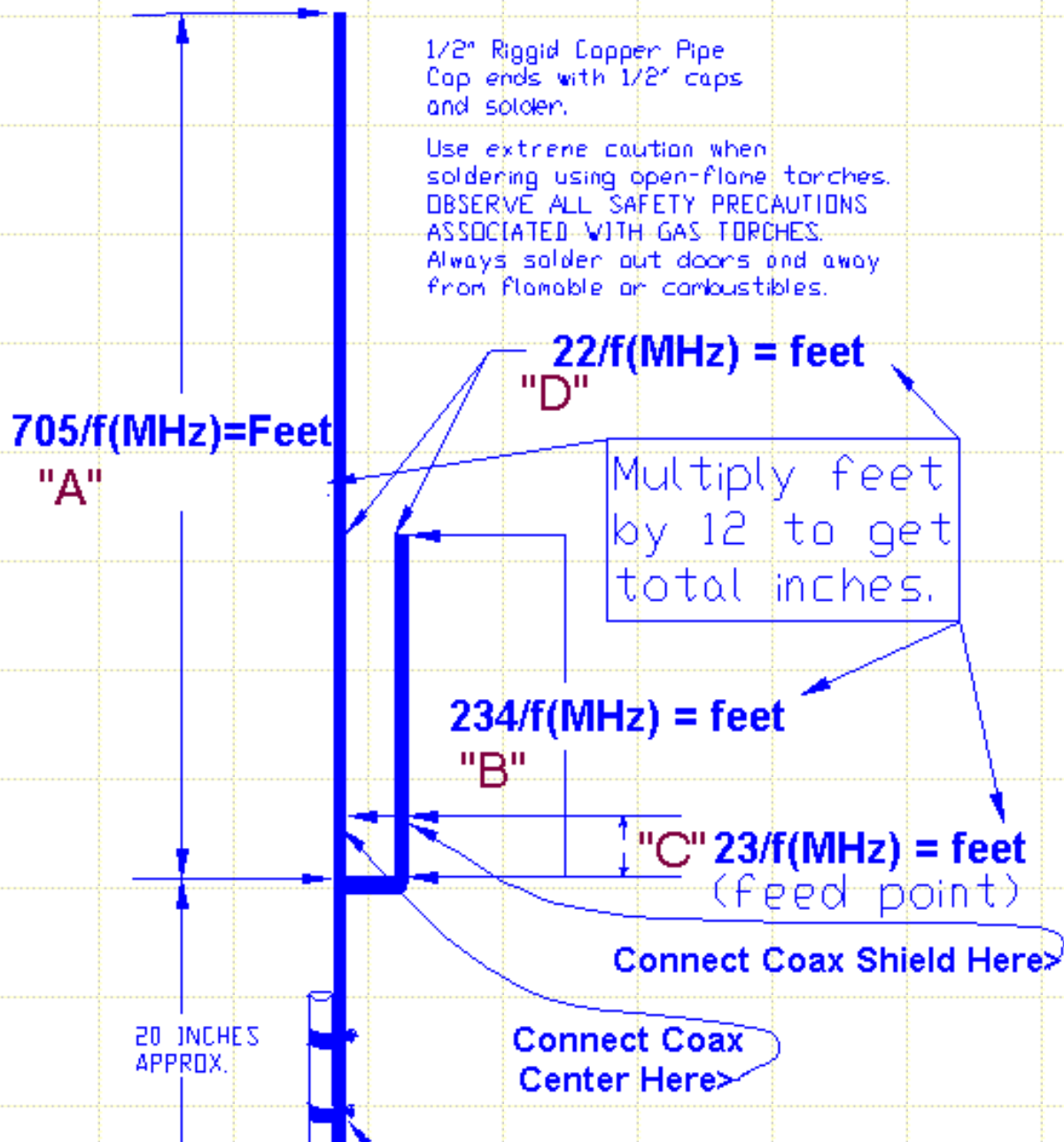

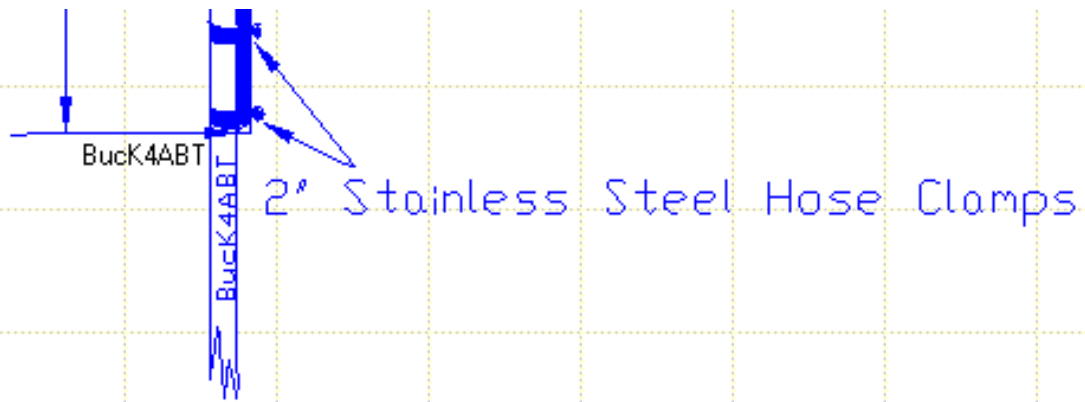

SAVE TIME BY USING THE HANDY J-Pole CALCULATOR BELOW.

NOTE: Coax center conductor attaches to the "Long section" feed point.
Shield attaches to the short section feed point.

Enter Antenna Operating Frequency

Freq MHz

| | | | |
|--|--------------|----------------|---------------|
| A (Long section) dimension is: | <i>feet,</i> | <i>inches,</i> | <i>meters</i> |
| B (Short section) dimension is: | <i>feet,</i> | <i>inches,</i> | <i>meters</i> |
| C (Feed point) dimension is: | <i>feet,</i> | <i>inches,</i> | <i>meters</i> |
| D (Spacing) dimension is: | <i>feet,</i> | <i>inches,</i> | <i>meters</i> |

*Inside (spacing) dimensions are metal to metal measurements, **NOT** center to center.*

RASCAL PSK Interface

[Click here to view an alternate method for feeding a VHF copper "J-Pole"](#)

[CLICK HERE](#) for a "close-up" of the alternate J-Pole feed method.

©1996-2004 G. E. "Buck" Rogers Sr.

 WebMaster, Buck Rogers K4ABT

Over Five Million Visitors "**0040290**" since January 2001

[Back to the *SEDAN* Antenna Designers Page](#)

[Go To the *BUX CommCo* Home Page](#)

[Go To the *PacketRadio* Home Page](#)



" This is Walter... Communication is dubious... I may have heard you, or your phantom transmission... I will attempt to reach your shadow and raise you..."

(Thanx Firesign Theatre)

THE LOW BANDS



If you like DXing on the low bands, 160, 80, 40, and 30 meters, these sites may be of interest- they include info about both TX and low noise receiving antennas and techniques. Enjoy!



| | | | |
|--|--|--|---|
| <u>KB1GW Beverage Antenna Collection</u> | <u>Funkenhauser MW DX Links</u> | <u>W3LPL on Beverages</u> | <u>Who's Who on Top Band</u> |
| | <u>Reversible 40m Delta Array</u> | <u>Flag & Pennant Antennas</u> | <u>K3KY's Short Beverage</u> |
| | NEW <u>FT-100D Diversity Rx</u> | <u>The K6STI Loop</u> | <u>Bobtails and Half Squares</u> |
| <u>High Band Bobtails/Half Squares</u> | NEW <u>The G3TKF Synchro Mod</u> | <u>The K9AY Loop</u> | <u>W7AV Tries a 40m Half Square</u> |
| <u>Top Band Reflector</u> | NEW <u>More Links- FT-100D Mods</u> | <u>Bobtails W4RNL</u> | <u>Half Squares W4RNL</u> |
| NEW <u>G4VGO 160m Kite/Balloon Ants</u> | NEW <u>EI7BA 160/80 Antenna Ideas</u> | | |

[EMAIL](#)

Send Comments to K3KY

Ham 'Treasure' Sites

[PREV](#)

[HOME](#)

K3KY's DX Toolbar

About K3KY

[NEXT](#)



K5DKZ



Antennas

[Short Dipole](#) - [Efficient Vertical](#) - [Beams](#)

[VHF Discone](#) - [Trap Dipole](#) - [40m Beam](#)

[Shunt Feeding a Tower](#)

[Some Basic Antenna Stuff and Ideas](#)

[AM Broadcast Band Loop](#)

[Multiband Antennas](#)



RADIO STATION KQ6XA

MINIBAC™

THE MINIMALIST BACKPACK™ ANTENNA SYSTEM

(C)1999, 2000 BONNIE CRYSTAL KQ6XA

HF Antenna for the Micro-Light Backpacking Enthusiast

SIMPLE CONSTRUCTION DETAILS AND SUGGESTIONS ON VARIOUS FIELD CONFIGURATIONS

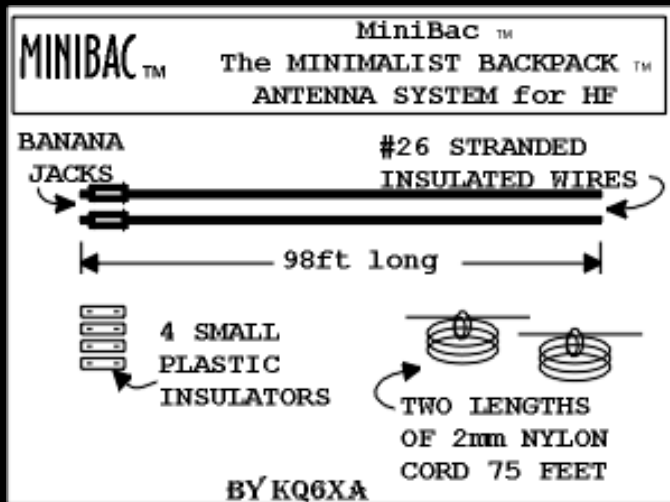

1

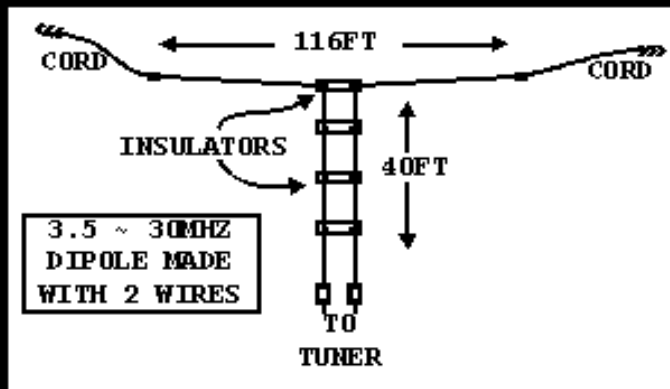

2

MiniBac.

The Minimalist Backpack Antenna System. Designed to be extremely efficient for both weight and radiation.

Components of the Minibac

| QTY | ITEM |
|-----|--|
| 2 | 98 FEET, STRANDED COPPER INSULATED WIRE, #26 AWG |
| 2 | 75 FEET, NYLON CORD, 2mm |
| 4 | INSULATORS, LIGHTWEIGHT |
| 2 | BANANA PLUGS |

Virtually unlimited configurations of the MiniBac are possible. Minibac forms its own feedline, which is quickly assembled in the field to meet the requirements of your site and choice of style. No lossy, heavy coaxial cable, or bulky twin lead is used. Open wire feed makes every precious watt count.

<#2-LEFT: The MiniBac forms a multi-band dipole using 2 supports, or an inverted-Vee with a single support.

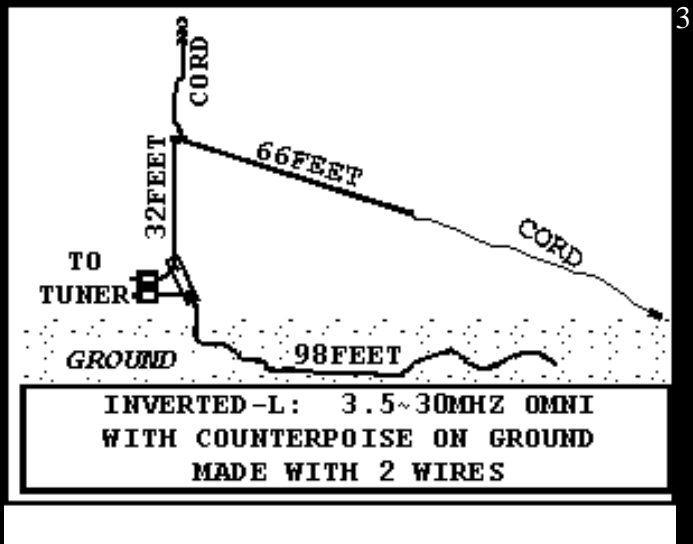

<#3-LEFT: Using a single support, such as a tree or pole, the MiniBac forms an Inverted-L with efficient counterpoise simply laid on the ground using no special alignment. This antenna configuration provides a good omnidirectional pattern, with both low angle and high angle radiation. While a tuner is suggested for multiband operation, no tuner is needed for 50ohm operation on 7MHz.

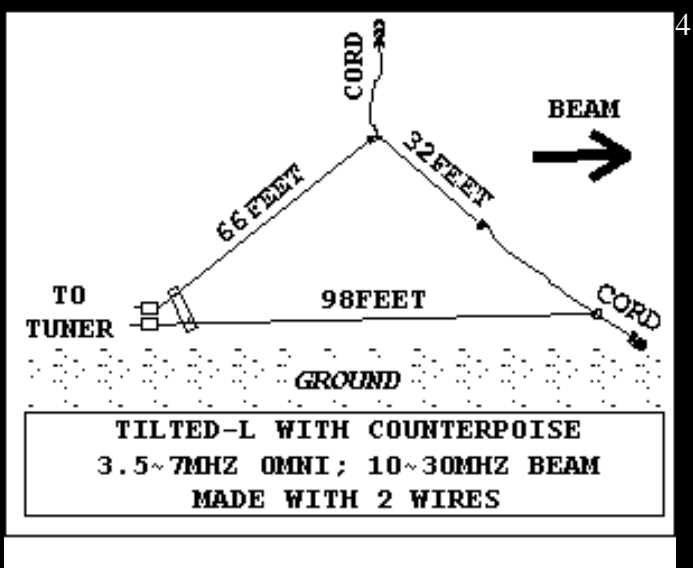

<#4-LEFT: Using a single support, such as a tree or pole, the MiniBac forms a Tilted-L with counterpoise raised above the ground several feet high. The raised counterpoise method provides slightly better radiation efficiency. This antenna configuration provides optimum low angle signal on 10 through 30MHz as indicated in the direction of the beam arrow. On 3.5 through 7MHz, it is omni-directional with high angle radiation for communications within about 350mile radius.

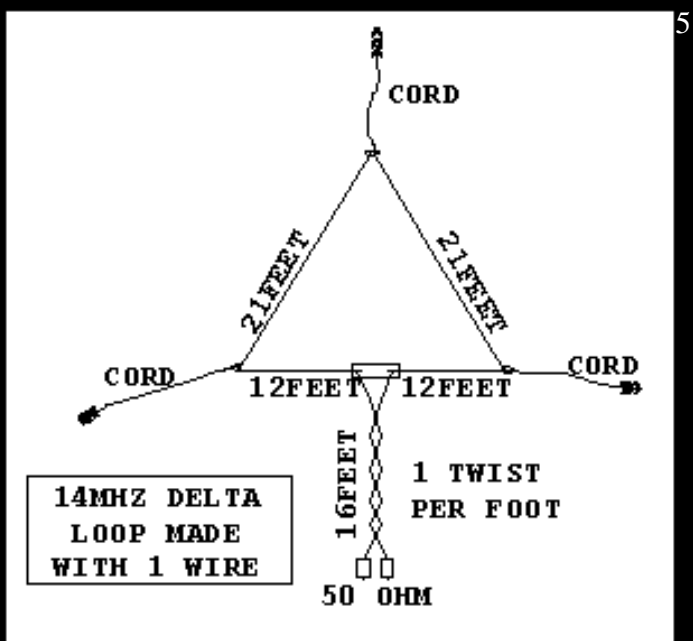

<#5-LEFT: A single wire of the MiniBac forms a Delta Loop antenna strung from a single support tree or pole. This method provides high efficiency with good directivity on 14MHz, requiring no tuner for 50ohm match. Using the twisted pair feedline, which can be run just above ground level, this configuration may be used with good success on other frequency bands, 18 to 30MHz, but a tuner is recommended. In addition, for 3.5 and 7MHz operation, the remaining MiniBac wire can be laid on the ground as a counterpoise, similar to the #3 Inverted-L, with the Delta-Loop and its feedline used as a vertical radiator against the counterpoise.

Ham radio operators are welcome to homebrew and use the MiniBac for personal and club use. Non-commercial use of the MiniBac name for ham radio in connection with the antenna is authorized. All commercial rights are reserved. Links to this site should direct to the home page. Permission for use of drawings should be requested by email.

Other Interesting Antennas by Bonnie Crystal

KQ6XA:

Broadband/Multiband Dipole and Tower Radiating Antennas for 80m and 160m
Using two towers spaced about 250feet apart --BONNIE KQ6XA

#1: Phased Array of Radiating Towers using Multiband 1/4 Wave Resonators for 160m/80m

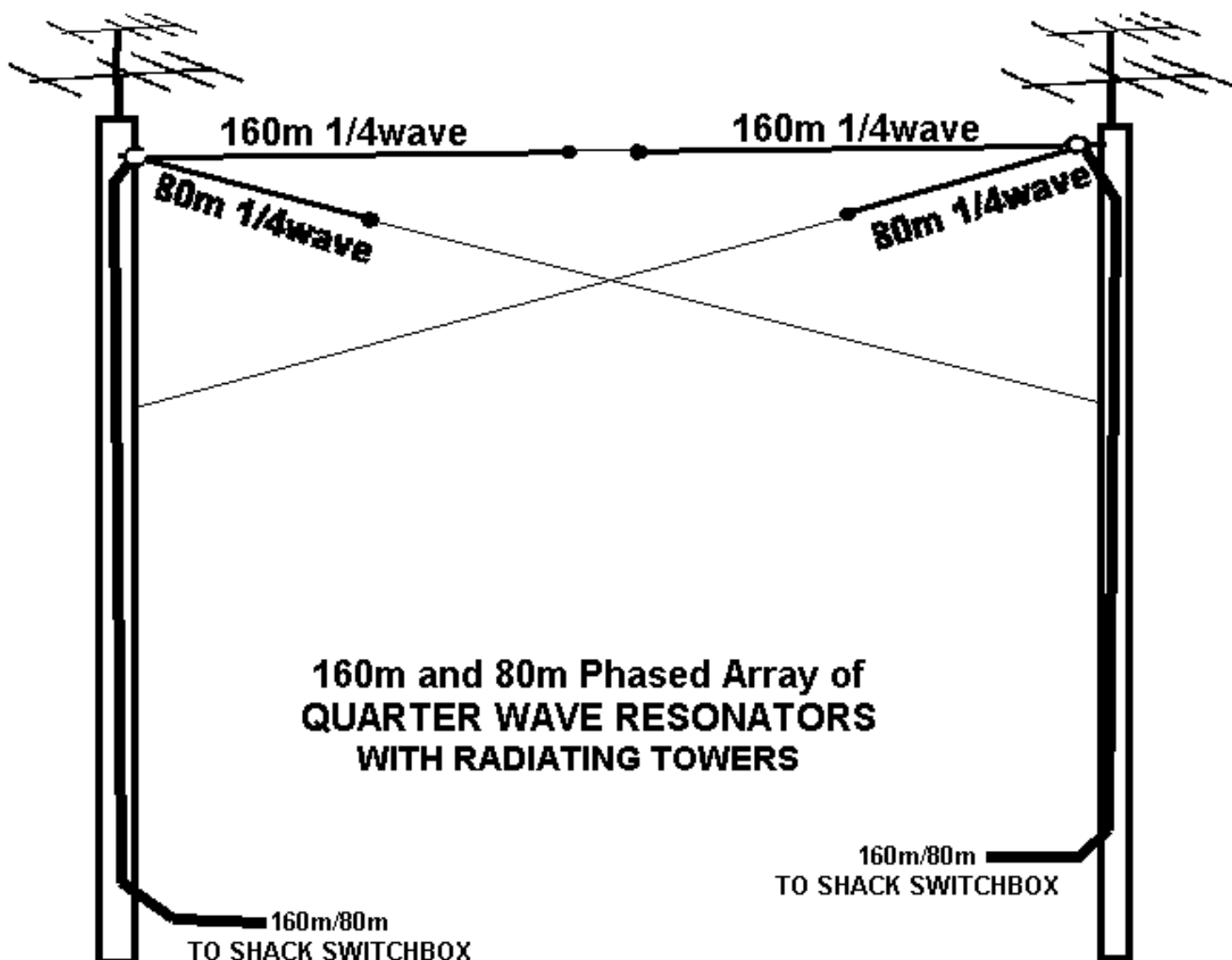

DETAIL VIEW:

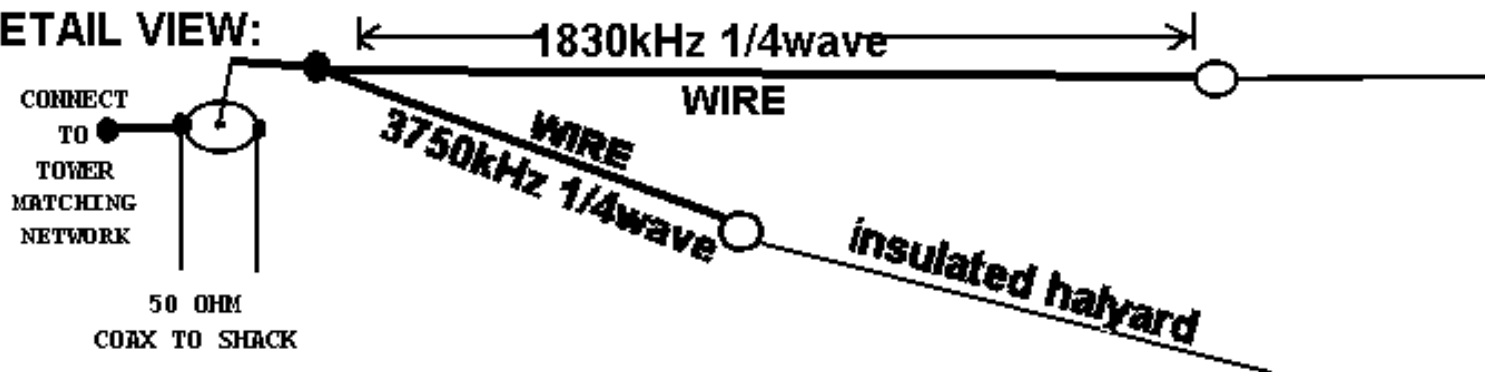

#2 Radiating Towers using Broadband 1/4wave Fan Resonators for separate 160m and 80m

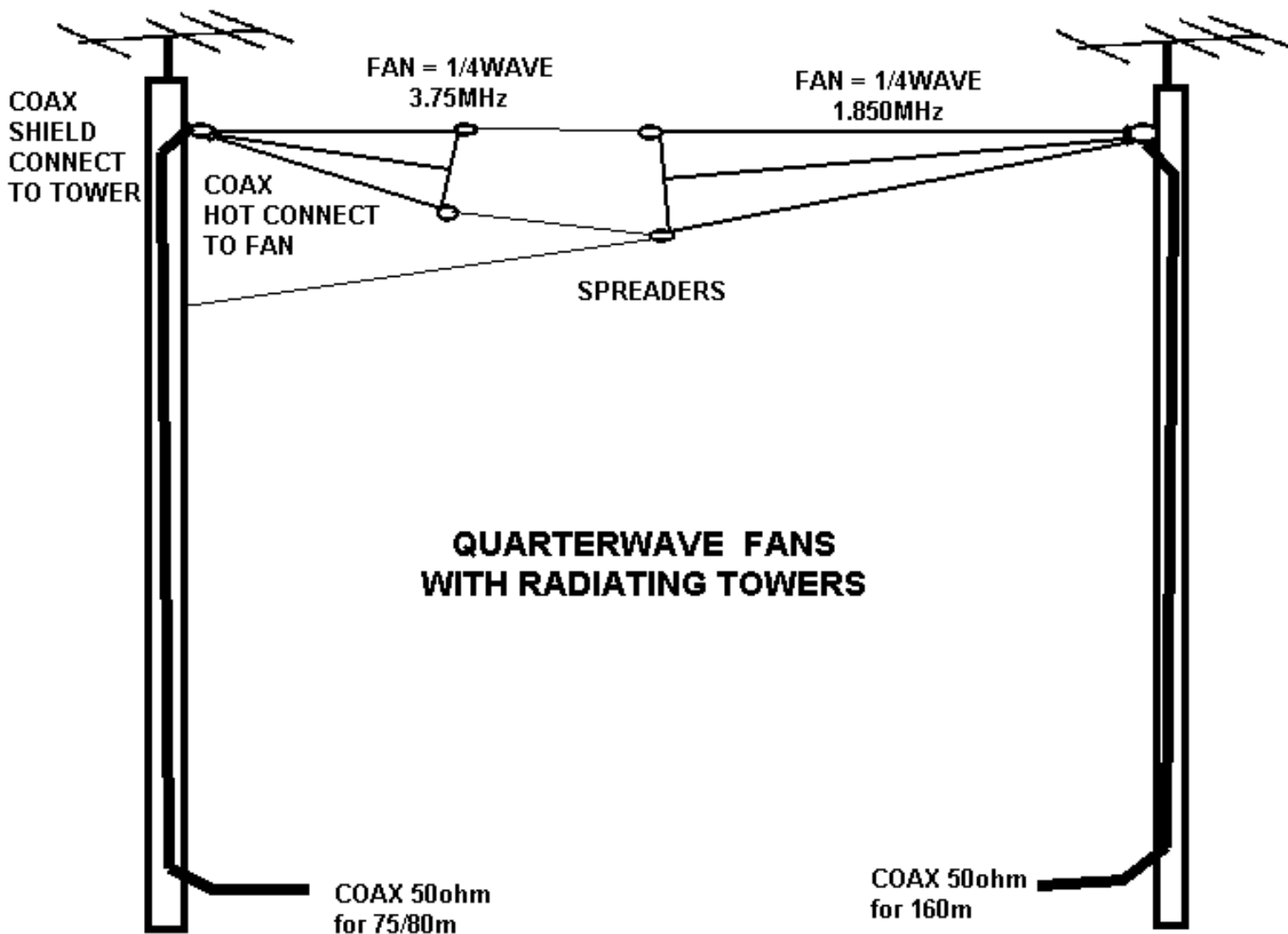

#3: Multiband Cage Dipole for 160m/80m

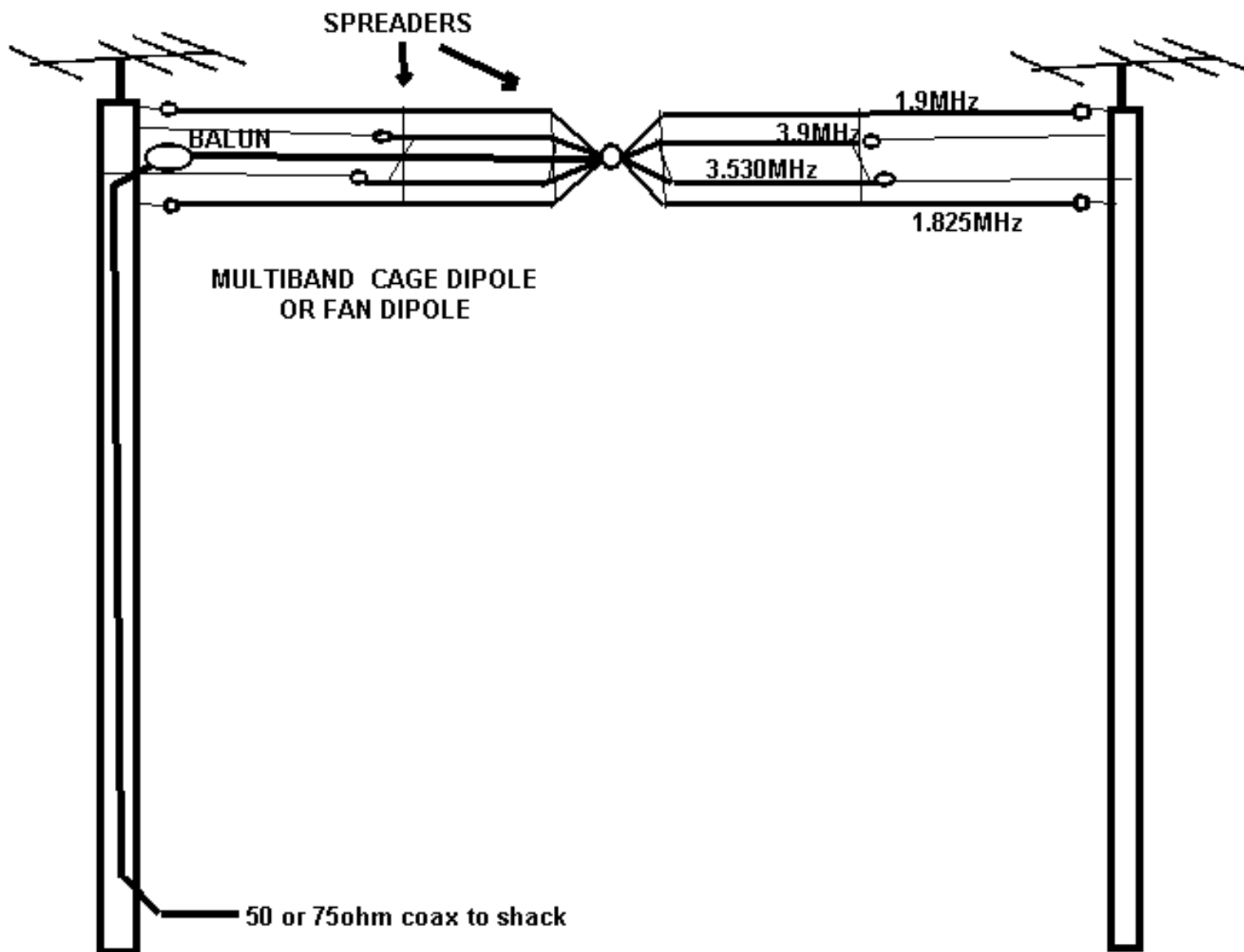

#4: Coaxial Bazooka 1/4 Wave Resonators with Radiating Tower for separate 160m and 80m

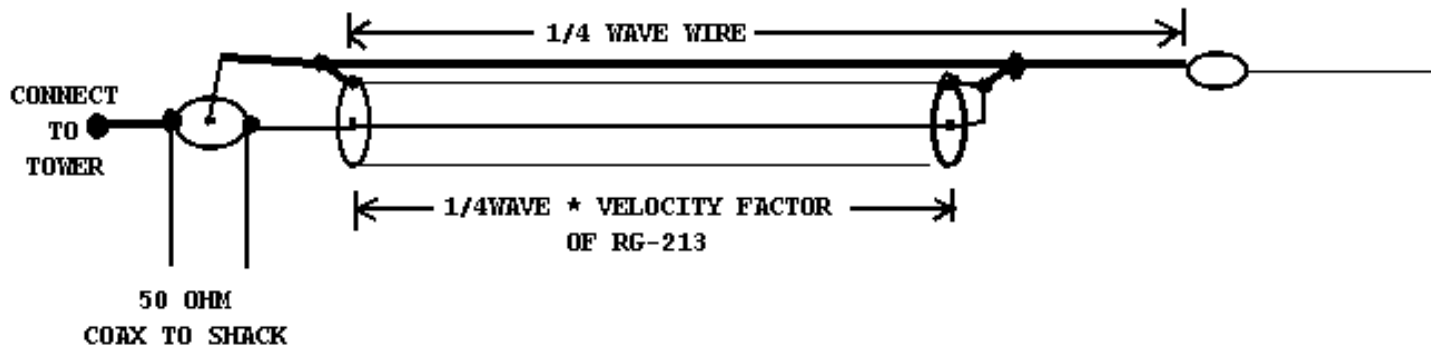
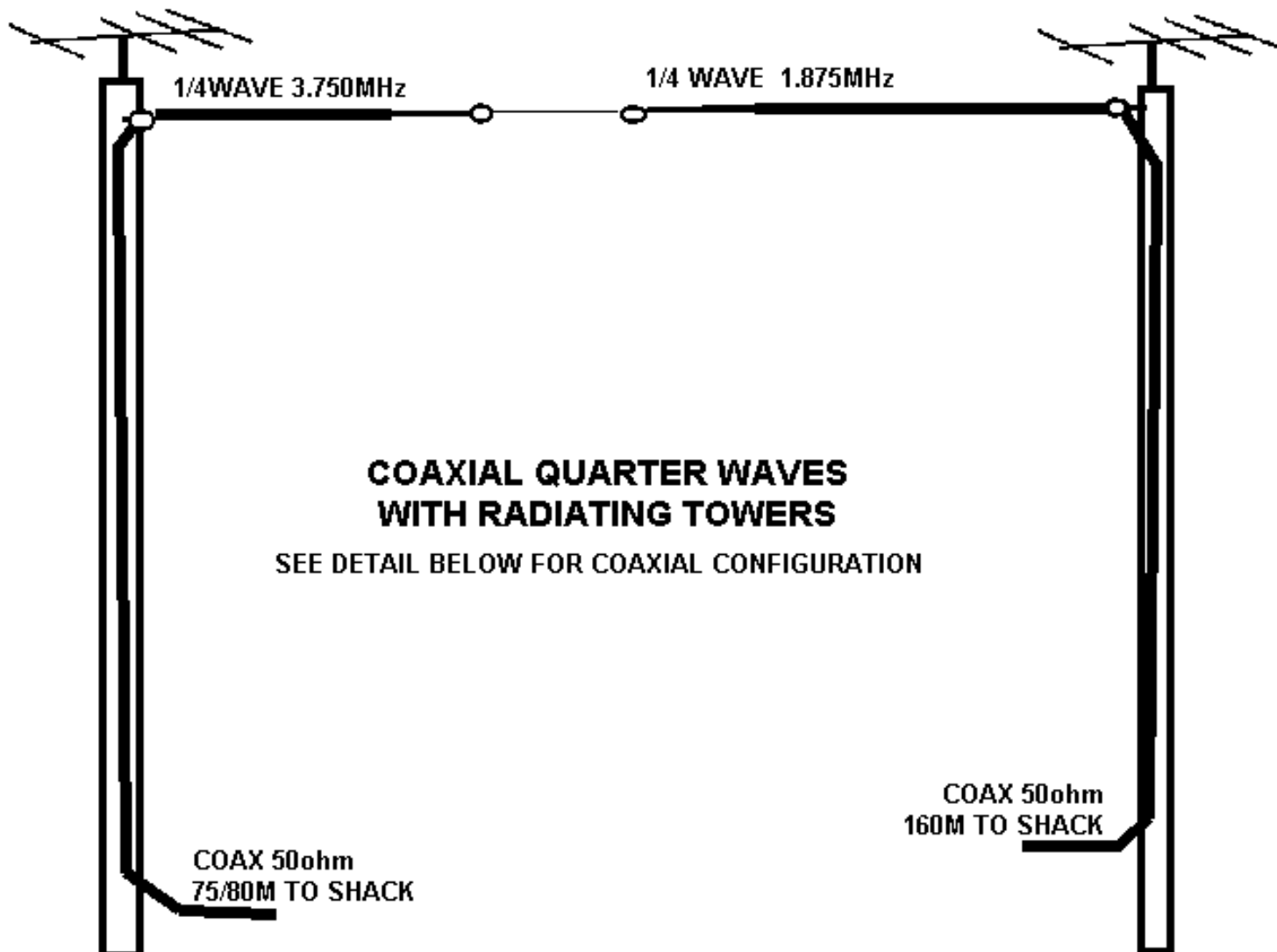

[CLICK HERE TO GO BACK to the KQ6XA HOME PAGE](#)



The K6STI Receiving Loop

This relatively unknown antenna does an amazing job pulling weak low band signals out of man-made noise backgrounds

DX SECRET WEAPON

Although it was prominently featured in September 1995 QST Magazine (p.33-41), I believe this antenna has been overlooked by a lot of low band DXers. Perhaps it seems a little too complicated, but I found it well worth the effort it took to design and build one. It is a terrific performer and has greatly exceeded my expectations. This is a low, medium size, horizontal loop with some *very* interesting characteristics. It has an omnidirectional, fairly low angle pattern with a deep overhead null like a vertical, yet it rejects vertically polarized RF energy and responds only to horizontally polarized energy. It offers a 25 to 30dB improvement in signal-to-noise ratio over a vertical for man-made noise. This is often the predominant noise type in densely populated urban and suburban areas. Results often seem magical as signals that are covered by noise on a vertical antenna become perfectly readable upon switching to the loop. A typical antenna is about 21 feet (6.5m) on a side and about 10 feet (3m) high. (Mine has 23ft (7.0m) sides) Height is not important as with Beverages- the antenna works just as well at 5 feet or 50 feet (1.5-15m). It is double-fed with ladder line in diagonally opposite corners to maintain good balance. The feedpoint is at the center of the ladder line. Coax from the receiver is connected through a matching network with a transformer and series resonating capacitor in the secondary, built in a weatherproof enclosure. For a 21 foot loop, there is a small impedance stepdown on 80m and a larger ratio on 160m. The antenna can be built with remote band switching, as I did with mine. It works well on 80 and has been surprisingly good on 160 (I had not expected much.) It is often my best performing low noise receive antenna.

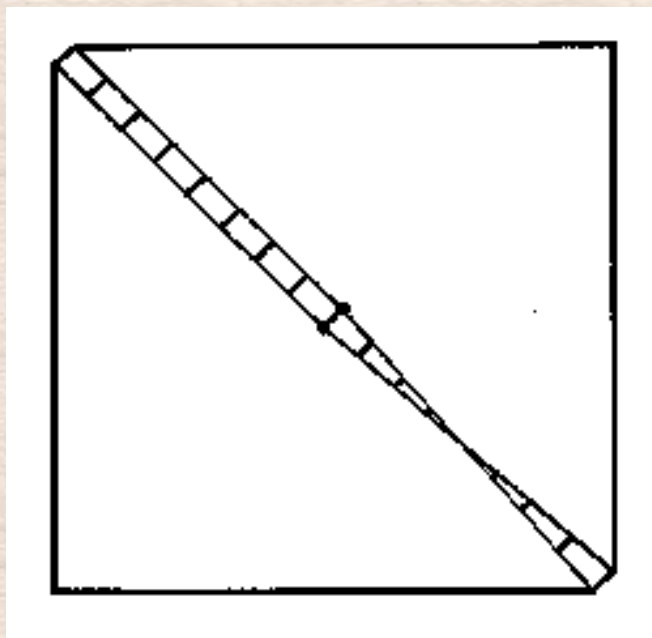

Low band operators who have already used Beverage antennas are nearly always disappointed with the K6STI loop. Beverages will 'spoil' you for any other low noise receive antennas, but many hams do not have room for them. If you want to reduce atmospheric noise and you do have some room for Beverages or phased verticals, both of which are directive, then those antennas would be a much better choice. Likewise, the WA2WVL cardioid loop array provides good directivity over a narrow bandwidth if you have the room- about 80 feet on 80 meters. (QST, August 1993, p.31) The Ewe, K9AY, and [Flag and Pennant](#) antennas also provide good directivity in a fairly small space, but with lower receive signal levels. They might benefit from the use of a receive preamp, and so might the STI loop, to a lesser degree. (I do not use a preamp with mine, however). It is a good idea to add a

highly selective tuning network ahead of any preamp to avoid receiver front-end overload. This loop has an omnidirectional pattern and, in theory, it should provide no improvement in S/N for atmospheric noise. K6STI and W6KUT, who built the first loop, noticed an apparent improvement of 1 to 2 S-units even when there was no detectable power line noise present. I have also seen this behavior in my antenna. STI reasons that in populated areas the noise background may consist of many individual man-made noise sources which, in composite, are characterless. Anyone interested in this antenna is encouraged to get hold of the QST article and carefully read and reread it for full understanding. Topband operators might want to consider building a double size loop around 50 feet (15m) on a side if it will be used only on 160m. Matching network component values would have to be adjusted accordingly. Because I do not have room for low band Beverages, the K6STI loop has proven to be a most valuable low noise receive antenna for me.

[\(Revised and updated 8 Apr 2000\)](#)

[\(Second update 13 Feb 2002\)](#)

W7LR tried a 50ft version of this antenna on 160m. He used a "pre-war" Terman handbook (p. 52) to determine that the loop inductance on 160m is about 110uH. He calculated the resonating capacitance at 1830KHz to be 60pF. His transformer was 4 turns, antenna side, and 20 turns for 50 ohm impedance coax. The core was an FB77-1024 ferrite bead. He said it "tuned nicely" (actual resonating capacitance was close to the predicted value). There were no comments as to the actual antenna performance, only that he has tried a lot more receiving antennas since this September 1995 design.

[EMAIL](#) Send Comments to K3KY

The Low Bands [PREV](#)

[HOME](#) K3KY's DX Toolbar

[NEXT](#)

Web page created by K3KY. All original content including text and photos is Copyright © 1996, 1997, 1998, 1999, 2000, 2001, 2002 by David E. Sinclair. Use elsewhere without permission is expressly prohibited.





k9ay loop

Antennas

Probably the best DX site in the world

DX news



More on K9AY

Basics

General info on the K9AY loop

Performance

Listening test and other observations

Homemade

How to make your own K9AY

Grounding

The importance of good ground

Wires

How to place wires best

Remote

Remote control of the KPAY

K9AY is a loop developed in the early 1990's by American radio amateur Gary Breed (K9AY).

Since then DXers, ham operators and commercial enterprises, all have raved and ranted about this loop, calling it "miraculous", "stunning" and the antenna that beats anything. While commercial K9AY can be bought at a price, this loop can easily be homemade at low costs.

Here we tell you all about it.

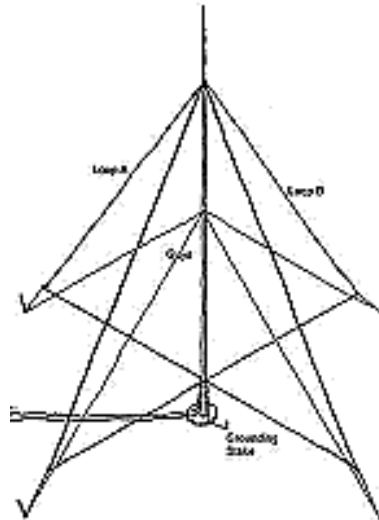

Basic info

K9AY compact loop for lower bands

Gary Breed, K9AY, has taken loop theory farther and describes an antenna that can be erected in almost any back yard and provides performance better than most antennas. -- [Read more](#) --

[Gary Breed's K9AY description](#) [PDF]

[Comments on the K9AY terminated loop](#) [PDF]

K9AY, *the* antenna for serious MW DXing

Bjarne Mjelde: This is without doubt *the* antenna for those who want to do serious MW DXing and do not have the space to erect multiple long beverage antennas. Its gain makes it very effective for any kind of DX – be it nighttime, greyline or daytime. -- [Read more](#) --

Wellbrook's commercial K9AY system

Dave Kenny, British DX Club: After some four months of using the Wellbrook's commercial K9AY I find that I am completely hooked and don't know what I'd do without it.

-- [Read more](#) --

Homebrewing

First K9AY for medium wave

Al Merriman, K4GLU, was the first to use this antenna for serious medium-wave DXing. A description of this loop. -- [Read more](#) --

- ▶ [Front page](#)
- ▶ [DX News](#)
- ▶ [Logs](#)
- ▶ [Andes DX](#)
- ▶ [Antennas](#)
- ▶ [DX Lab](#)
- ▶ [In Print](#)
- ▶ [Web Stories](#)

Archives

- ▶ [Web Archive](#)
- ▶ [Mail Archive](#)

Search

- ▶ [Search all HCDX](#)
- ▶ [mail since 1995](#)

About us

- ▶ [About us](#)
- ▶ [Write to us](#)
- ▶ [Copyrights](#)
- ▶ [FAQ](#)
- ▶ [HCDX mail list](#)

Build your own K9AY

The performance of the K9AY is miraculous, says *George Maroti*. Then gives details on how to construct one yourself. -- [Read more](#) --

Connelly's loop version

Mark Connelly's version, with drawing, of a K9AY loop. Also describes a scaled-down version of the loop.

-- [Read more](#) --

One step further: two loop system

Having adapted the original ham K9AY loop, *Al Merriman* took the antenna one step further, by setting up a two K9AY loop system.

-- [Read more](#) --

Two loops working as four

Johan Bodin: I think I have invented a way to make two loops appear as four loops... -- [Read more](#) --

Going even further: 8 loop system

A system with 8 loops definitely works, but there are situations where nulls are difficult to get. -- [Read more](#) --

Modifications to the K9AY loop

Six suggestions to make your K9AY loop work even better.

-- [Read more](#) --

More on loop modifications

Single loop will work fine. Also proof for the need of a 9:1 matching transformer. What wire length is best for medium wave. -- [Read more](#) --

Make yourself a portable K9AY

It takes some time to build, but after that you can have your setup up and running in 30 minuter. -- [Read more](#) --

Make your own transformers

Make your own broadband transformer for the K9AY; or buy one ready made from Mini-Circuits. -- [Read more](#) --

Make your own Vactrols

Two ways of producing your own Vactrols for use with your homemade K9AY. -- [Read more](#) --

Check for worn out Vactrols

George Maroti: How to check for worn out Vactrol, without removing the Vactrol from the circuit board.. -- [Read more](#) --

Performance

Stunning K9AY loop test

On a couple of dozen MW signals from Japan and the Koreas, the beverage *never* out-paced the loop. -- [Read more](#) --

Saviour in the noise

Werner Funkenhauser: I had almost given up on DXing, due to a high noise location. Then came my saviour, the K9AY loop. -- [Read more](#) --

K9AY compared with Beverages

Martin Elbe: The K9AY turns out to be an excellent performer, able to beat the Beverages in some cases.

-- [Read more](#) --

Why doesn't K9AY work for me?

Discussion on how to make the K9AY loop work as intended.

-- [Read more](#) --

Grounding

Important with good grounding

The K9AY antenna doesn't work without ground. It needs *really good* ground to performe optimal. -- [Read more](#) --

Use many ground rods

Add many more ground rods, and you will get increased gain.

-- [Read more](#) --

How to balance your antenna

Tom Rauch, W8JI: Discussing the need, or not, for shielding metal boxes, and how to balance different antennas as Beverage, small loops, Flag and Pennant.

-- [Read more](#) --

Wire matters

Loop wire separation not needed

Andy Ikin, Wellbrook: There is no real need to separate the two loops. In fact the two loops can be shorted together at the apex with no measurable affect. -- [Read more](#) --

Shape of the K9AY loop

Guy Atkins: While the K9AY is a crossed-X delta loops, other wire shapes may give good results. -- [Read more](#) --

150 feet should cover medium wave

Antennas up to 150 feet in length, and maybe just a bit more, should

give full medium wave coverage. -- [Read more](#) --

Twin wires gives more gain

Andy Ikin: Experimenting with two wires shows a greater gain. More experiments needed to fully explain why. -- [Read more](#) --

Height above ground to be determined

Andy Ikin: I think some experimentation is required determining the distance above ground of the lower part of the K9AY loop.

-- [Read more](#) --

Remote controlling

Variable termination an absolut must

Variable termination using a Vactrol or some other method is an absolute must. Peak performance cannot be realized with a fixed resistor. -- [Read more](#) --

Kites and Aerials

[[Home](#)] [[Up](#)]

Click [HERE](#) for the
Amazing [Online Ham](#)
[Radio Flea Market](#)

Kites and Aerials

Choosing your kite



[6.7m fibreglass
poles for sale
click
HERE](#)



I'm the world's worst kite flier. It's official. I spent most of my childhood running up and down beaches with sticks, cloth and string. I had not got a clue and neither, it seems, had any of my aunts, uncles and other relations. Perhaps it runs in the family?

So, why am I telling you this? The reason is simple, I reckon that I'm uniquely well qualified to talk about the subject. After all, if I can get a kite to work then you will be sure to be able to get it to work better!

My involvement with kites for radio started in 1981. I was getting ready to go off to Antarctica as VP8ANT. Being a great planner, I was thinking about how to make sure that I could get on the air from there and kites came to mind. I think it may have been due to reading that Antarctica was the windiest continent. Anyway, either that year or the year before there had been an article in QST about

Search G3CWI's site

a new kind of kite. It was called a parafoil. A company called Jalbert Aerotechnology in Boca Raton (?) Florida was making them. I sent off for some information and they sent me a brochure. These kites were not cheap but they did look promising. They have several special characteristics that make them good for aerial work:

- they are very stable in flight
- they fly at a high angle
- they are light and easy to fly
- they have no rigid parts whatsoever to get broken.



The traditionalists use box kites (I think Marconi started that off) but I knew that I would never get one of them into the air!

My kite arrived and I set about testing it. The amazing thing was that I could launch and fly is easily - I have NEVER had to run with this baby. And what's more it performed exactly as the sales literature said. Bliss.

After a while I got to flying it in stronger winds and then on one sad day, the 100 pound breaking strain line broke. Off sailed my kite, landing in a field of wheat. There was no chance of finding it. I wrote to Mr Jalbert and explained that I was hoping to take the kite to VP8 and that his recommended breaking-strain line had broken. By return, he sent me a new kite - no charge. That's good service!

Anyway, some months later, the wheat field got harvested and the harvester driver actually spotted the kite and retrieved it in tact. That was 1981. I have both kites here to this day.

Don't choose a kite that is too big. Mine seems to be about the right size for most aerial applications. The bigger ones will be impossible to handle in anything but a light breeze. Bigger is NOT better here!

So here is the first lesson. Spend some money on a really good kite (a Parafoil) and it will last for a long time and do great service.

Antarctica

Suitcase packed, off I headed, with my kites in tow. Boy was it windy. I set about trying to break the endurance kit flying record. It was a windy day and I managed about 18 hours before the wind really got up and the string broke again. However, there was not a wheat field for some distance so I managed to get the kite back. Parafoils need the tension of the string to fly. Once the string breaks the fly like a stone. Quite a handy characteristic.

On a field trip. I launched the kite from my sledge and called the base. they were rather surprised to get a call during the day but the kite certainly enabled me to put up a good aerial. I have a picture of this event which I must scan in some time.

I also used the kite to launch an aerial to make some QSOs on 20 metres - reaching back to the UK with just 8 Watts of SSB. So the kite was a success.

Aerial types

There are several choices. The most obvious is to use an end fed wire as the "string" for your kite. However, as the wind varies, the angle and direction will change (often a lot) which can be undesirable. I tend to hang a wire of the string, about 100 feet down from the kite. This gives a vertical aerial that is much more stable. Add a few radials and a tuner and you're in business.

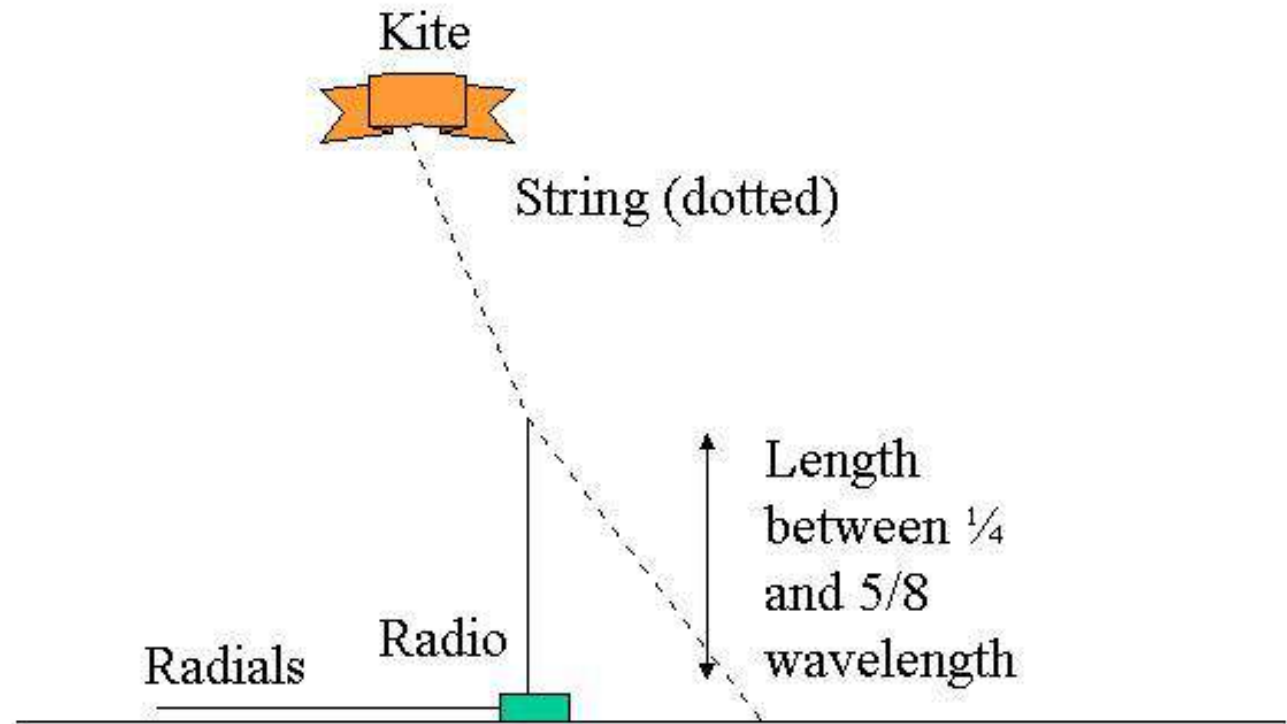

With two kites, you can be more ambitious and I have flown a large inverted L before. However, my 80m $\frac{5}{8}$

wavelength vertical seems to have been the best performer.

Some further thoughts are to use an end-fed half-wave inverted vee configuration with the feed point at ground level and the current point at the peak of the vee. This would be a good choice for near vertical incidence communications on the lower band and DX on the higher band (say 40m and 20m).

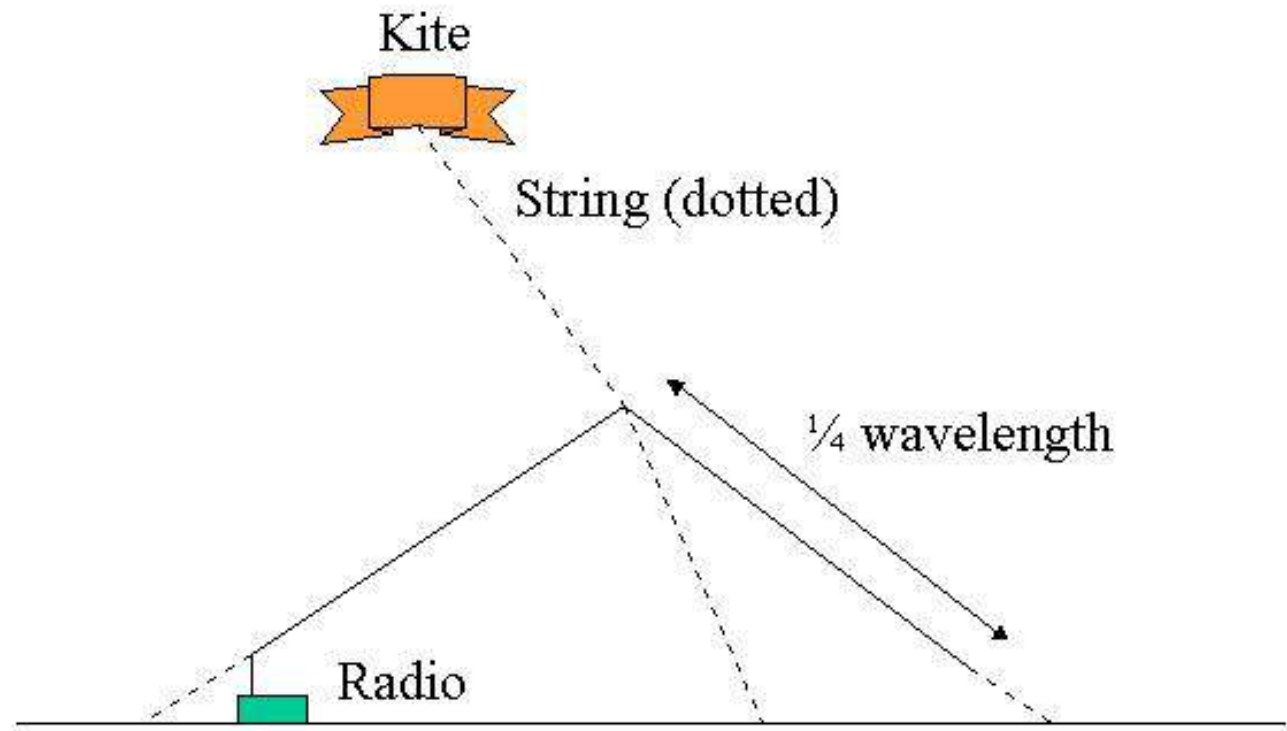

I did a test run of the configuration above on 4th July 2001. The aerial seems to work adequately. The kite needs to be well above the apex of the aerial to be clear of the vortices that exist around hill tops. Aim for 150 feet above the ground before the aerial is attached.

A further option would be a diamond aerial. This can be used on two frequencies (an octave apart) by simply opening or closing the circuit at point A. With a short at point A it would work on the lowest frequency (7MHz for example) while an open circuit would allow the aerial to work on 14MHz. This would be a useful scheme for K1 40/20 owners. The loop can be fed with open wire line.

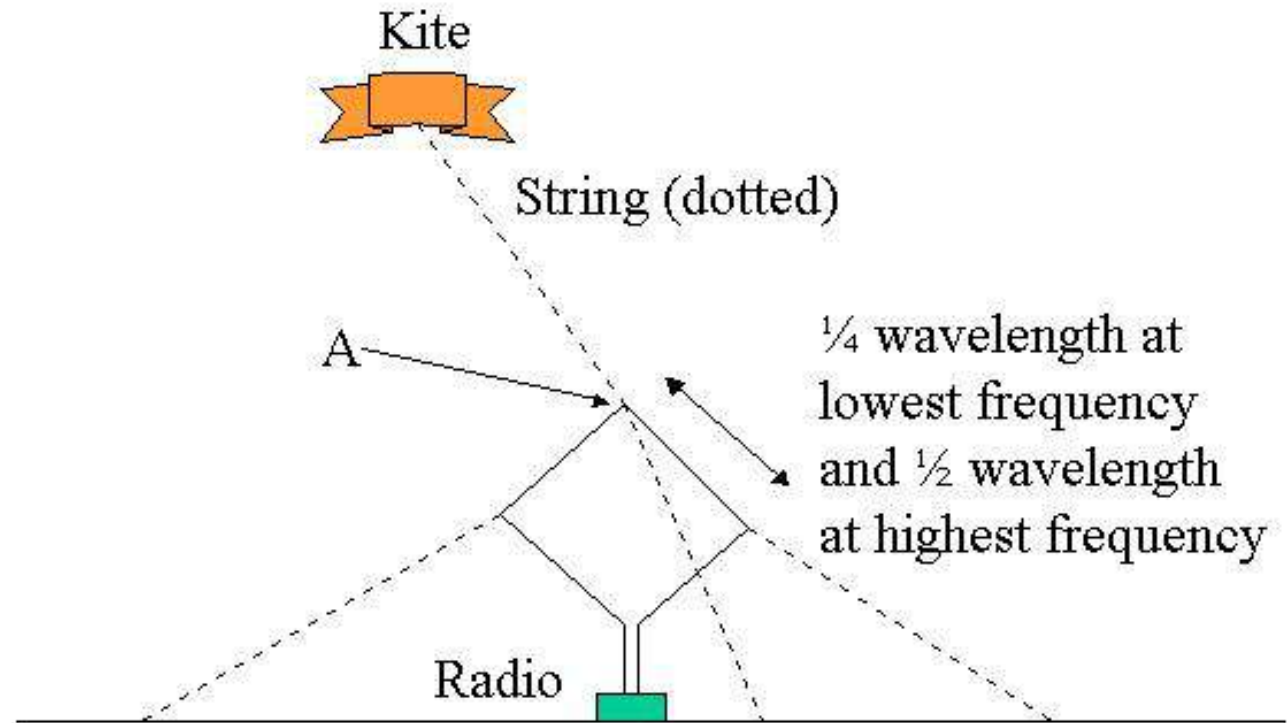

Caution

Avoid power lines. Avoid aircraft (my kite has been up to over 1000 feet). Avoid lightening. Avoid static rain. Any or all of these could get someone killed.

Buying your kite

Jalbert Aerotechnology don't seem to be on the web so perhaps they have gone. There are however other Parafoil manufacturers about.

More general information about parafoil kites [here](#).

Sources of kites on the WWW - **you** judge if they are ok!



[[Home](#)]



Kites for Lifting Antennas

The Weather Service both in the US and abroad, made extensive use of kites for lofting weather instruments in the period from 1880 to 1920. Also kites were tested for man lifting in the same period, for applications like military observer. What was accomplished was just remarkable.

Versions of the winged box kite was the champion in all cases. But that was before the unsparred, parafoil kites we have today were invented. The standard was a box kite called the Blue Hill Meterological Box Kite. It had a rectangular section when viewed from the front.

Today, there are special kite stores, so one is not limited to what you can build from plans in books, or the cheap paper diamond kites sold in toy stores. Any good kite store will be loaded with the fancy, and expensive aerobatic kites, but they should also have excellent load lifters, if you know what to ask for and look in the dustier corners:

-
1. **The Classic Box Kite.** This was a standard, considered by some hard to fly. Multicell box kites are complex to build, but work well. Some of the variations include a tetrahedron shaped box kite, but it is mostly good looking, not a good lifter like the classic box kite.
 2. **The Winged Box Kites.** Probably the best of the rigid kites. The triangular winged box kite is a great lifter. The French Military Kite, is a classic. Dihedral wings on box kites add to stability and lift. One of the most famous man lifting kites was a several-celled box kite with small wings, the Cody Manlifter. [No, that is not Buffalo Bill Cody, but a person often confused with him, Sam Cody, an early kite/aeroplane pioneer.]. You can even purchase modern versions of the Cody Manlifter in several small sizes. It is an excellent design.
 3. **The Parafoil.** A commercial company makes four sizes usually available. The sizes are rated in square feet of area and go from pocket size to a bit less than four feet wide and a bit less than five feet from front to back. They are attractive because they fly at higher string angles than the box kites, more vertical. They pull like a demon, with the largest size recommending 250 pound test flight chord. They wad up into a stuff sack that is very easy to transport, since they have no sticks or spars.
 4. **The Sleds.** In its simplest form the sled is a flat piece of cloth tied at the right and left side to the bridle, with two spars running from front to back to hold it rigid in one axis only.
-

The **parafoil** along with the **sleds** have a disadvantage in gusty winds. They will collapse in the air and fall like a rock, all the way to the ground if they do not reinflate in time. The **rigid kites** are far more immune to gusty winds. But they have spars etc, that make them harder to pack, and heavier. Some of the

kites of the 1890's had so many spars, cells, cross supports, braces, etc. that they were as complex as the early aircraft. The Cody Manlifter was very picky about having the fabric tight, thus having curved edges.

The Scott Sled and its variants is a good stable kite that is spared in one direction only, front to back. The Allison Sled is a variant of it. Various versions add vents in assorted patterns which are alleged to increase stability and tolerance for wind variations. For wind measurements I have flown simple tethered sleds in the trade winds for weeks at a time. Our record was nine days that a sled stayed up, staked to the ground, day and night, through land breeze/sea breeze transitions, with no intervention. It was finally collapsed and knocked down by a nasty gusty roller of air. It took seconds to shake it open and relaunch it.

Other kites that are useful as lifters include double triangular winged box kites, Coynes, and even the Malay kite which is the stock diamond shaped kite just about everyone bought at the toy store as a kid and played with. A Malay is certainly easy to build and will loft a small antenna wire, but it is unstable without a drag producing tail, at least when compared to things like winged box kites and parafoils.

One person has made a study of sewing a type of vented sled kite that is kind of a cross between a Scott Sled and a Parafoil. He has flown some very large ones which he has made and used them to do heavy lifting, and launch a squadron of parachuting stuffed bears.

The U.S. Weather Service standardized on the "French Military Kite", a triangular winged box kite. The kite is like a classic box kite, but only with three sides to the box instead of four. It also has dihedral wings added to one surface which greatly increases its side to side stability. The Weather Service flew trains of these kites to increase lift and stability since they sampled air at multiple levels, much like space diversity receiving. One such train of kites was flown to 27,000 feet! The pull was so great that these trains of large kites were flown on piano wire, a very dangerous practice for the amateur. The Blue Hill Box Kite was another weather bureau standard. It was a large box kite with a rectangular cross section cells about three times as wide as they were high, but otherwise similar to the standard two cell box kite. It had one fore cell and one aft cell with fore/aft spars holding the two cells in alignment.

On the top of Mauna Kea (13,380 feet) I have flown a small sled through two changes of wind direction and been able to look up and see the kite string make a full spiral above my head as it rose the several thousand feet to the kite itself. The string was very small, but Kevlar with an incredible breaking strength that would slice off fingers before it broke. One weather service report from the 1920's reports a train of kites that made nine revolutions of a spiral as it ascended above an observer through multiple changes of wind directions.

You should not use the antenna wire as "kite string", but support the kite with a flying string and parallel or hang the antenna structure from the flying string. A kite carrying away in a wind with a trailing antenna wire is a dangerous situation. You should make sure that if the kite breaks free, it cannot take the antenna wire with it. One way of helping to insure this, is to use a stouter cord below and through the

antenna bearing section, and a lighter cord above, so if the kite carries way, it is more likely to break off above the antenna section.

Big Kite + Stiff Trades = Major Tension

One last word of warning. If you get a decent large kite, like a six foot triangular box kite or a big size 15 Parafoil, get some serious kite cord, something well over 125 pounds. Also purchase some heavy duty leather gloves with wrist protection flanges on them, like gauntlets. Do not underestimate the potential dangers of flying a large kite in any kind of wind.

These big kites are renowned as lifters for a reason. A large kite needs preparation before launching into any wind regime. A modern ripstop nylon kite in a large size is NOT the toy paper dimestore kite of your youth, flown with cheap cotton twine.

A toy paper kite will tear up in too much wind. The flimsy cotton string used will break easily and is not prone to rope burns, slicing wrists to the bone or popping off fingers at the joints. The flimsy spars of the dimestore kite will snap easily if overstressed. Thus it is relatively safe to fly such a kite.

A kite made of ripstop nylon, carbon filament spars and flown with heavy duty nylon cord is a very different item that must be respected.

The first time you try to hang onto a large parafoil in a stiff 30 mph wind, you will know what I am talking about! Rope burns can happen quickly and cut to the bone or worse. Hand protection is mandatory. Rope burns are terrible. The skin and muscle are "erased" away leaving a deep trench that is slow to heal and very, very painful.

It is well worthwhile to invest in a small parafoil or winged box kite suitable for 40 or 50 pound line and test fly it to get a feel for heavy duty kites. Remember, a kite twice as large is going to have a pull four times as great or more. Also pull goes up with the cube of the wind speed!

The large military kites were flown from special trucks that carried large drum wenchers. These kites were only about three times larger than kites easily available at kite stores today and routinely lofted observers to several hundred feet in WWI.

An interesting "target kite" was used in WWII that had a metal rudder on a 10 foot tall Malay type kite with a black aircraft silhouette painted on it. It was towed behind a jeep with an "operator" in the back who used a pair of control lines to manipulate the rudder on the kite. The jeep would go around an oval course while 50 caliber machine gun trainees would blast away at the kite above.

A friend had one of these and we would fly it in Oklahoma from the ground using a 4x4 inch oak wood beam, 6 feet long, as a flight handle. We would stand behind a telephone pole and let the pole take the

strain of the kite on the 4x4 handle and still be able to loop the kite and steer it by rocking the 4x4 back and forth behind the pole. It was impressive to see the divot ground into the 4x4 where it was bearing against the telephone pole.

One report of an experiment with 160 meters raised several interesting points. The objective was to fly a kite next to the ocean and use the Pacific Ocean as a ground plane. It worked extremely well but had two major problems.

1. It picked up literally volts of signal from the local high power AM broadcast stations, blotting out the front end of the receiver. Clearly, unless you are quite far from such a broadcast site or sites, you need to have a carefully built filter box. Probably bandpass with the major rolloff being on the low side of 1.8 Mhz. Possibly even a tunable notch section in the middle as well. Of course the usual static grounding of wind generated static electricity is essential. Any kite antenna **MUST** have a path to ground. A choke or a high value carbon resistor should work. In the case of a 160 meter antenna, the AM broadcast blocking filter could easily be designed to have as its first component something to provide a DC path to ground.

2. A kite that has fallen into the ocean is a monster sea anchor. Rip tide can make a kite impossible to retrieve. Kites have been built with collapsible harnesses. This is probably a great idea. Basically one examines the harness that holds the kite in the right aspect to the wind stream. Find a critical part that sets the angle of attack. Make this with a link of much weaker string than the rest of the harness and the flight line. Thus a abusively strong yank on the flight chord will break the harness causing the kite to flatten out and stream. Such a harness modification would have made it possible to retrieve the kite in the ocean. Since fancy lifting kites can cost a hundred dollars or more, getting the kite back is a priority.

Finally, consider a 1/4 scale model designed for 40 meters. It will solve a lot of problems and give a lot of experience at much less expense and hazard. Anything for 160 meters is just plain BIG.

One last word, if the kite is big or flow high, you can get into trouble with the Federal Aviation Administration. Here is a sample peek at typical FAA regulations. For most up to date information you should check the FAA's own web pages:

[FAA Part 101](#)

[Return to UH Ham Club Home Page](#)

06/02

W2IK's LADDER-LINE BACK PACK SPECIAL

GREAT FOR CAMPING OR EMERGENCY COMMUNICATIONS

BOB HEJL - W2IK

1568

HITOMETER

EVER WISH YOU HAD A VERY SIMPLE, LIGHT WEIGHT HAM RADIO ANTENNA THAT COULD BE STUFFED IN YOUR BACKPACK AND DOES NOT NEED A TUNER? HERE IS A SIMPLE DESIGN THAT I BUILT MANY YEARS AGO AND FOUND IT TO BE VERY USEFUL WHILE CAMPING OR FOR EMERGENCY COMMUNICATIONS. IT'S GREAT IF YOU DON'T HAVE THE ABILITY TO TAKE ALONG MY ["IK-STIC 2"](#) **ANTENNA** (TO BUILD THAT ANTENNA, CLICK ON THE RED "IK-STIC 2" TITLE)

WHEN YOU ARE CAMPING, YOU HAVE TO MAKE COMPROMISES. THE SAME IS TRUE ABOUT CAMPING WITH HAM RADIO. USUALLY YOU'LL BE OPERATING ON 20 METERS IN THE DAY AND 40 METERS AT NIGHT. THAT BEING SAID, I DEvised A VERY SIMPLE ANTENNA IN A SINGLE FORM THAT WILL COVER BOTH BANDS WITHOUT THE NEED FOR A TUNER.

TO BUILD THIS ANTENNA YOU WILL NEED

50 FEET OF 450 - 600 OHM LADDER LINE (NOT TWIN LEAD)
2 THREE INCH PIECES OF 1/2 INCH PVC TUBING
ONE CENTER CONNECTOR (DIPOLE TYPE-WIRE TO SO-239 CONNECTOR)

UNROLL THE COIL OF LADDER LINE AND CUT THE LADDER LINE IN HALF SO YOU HAVE TWO LENGTHS EXACTLY 25 FEET LONG. EACH LENGTH BECOMES A SIDE OF YOUR DIPOLE SYSTEM. AT THE EVERY END OF EACH WIRE, STRIP OFF THE INSULATION EXPOSING ABOUT 4 INCHES OF BARE WIRE. ON ONE SIDE OF EACH LADDER LINE TWIST THE BARE WIRES TOGETHER AND SOLDER ONE END OF EACH LADDER LINE TO THE WIRES ON THE CENTER CONNECTOR.

(SEE PICTURE BELOW)



AT THE OTHER END OF EACH OF THE LENGTHS OF LADDER LINE, TAKE ONE PIECE OF 1/2 INCH PVC TUBE AND SLIDE THE WIRES THROUGH 1/4 INCH HOLE DRILLED NEAR ONE END OF THE PVC TUBE. PULL THE PVC AROUND SO YOU CAN CONNECT THE WIRES TO EACH OTHER AND SOLDER THEM TOGETHER.

(SEE PHOTO OF THE END INSULATOR BELOW)

DRILL ANOTHER 1/4 INCH HOLE ON THE OTHER END OF THE PVC TUBE SO YOU CAN HANG THE DIPOLE SYSTEM UP USING NYLON CORD.



THE SPECIAL CUT

NOW JUST ONE MORE THING TO DO. IN ORDER TO MAKE THIS A 40 AND 20 METER ANTENNA, YOU NEED TO MEASURE 16.4 FEET FROM THE MIDDLE OF THE CENTER CONNECTOR AND ON ONE WIRE OF EACH SIDE OF THE LADDER LINE YOU WILL CLIP OUT A 1/4 INCH SECTION OF WIRE. IF POSSIBLE, CLIP THE SECTION OUT WHERE THERE IS A SEPARATING PIECE OF THE LADDER LINE WEBBING SO THE ANTENNA WILL BE PHYSICALLY MORE STABLE.

THIS WILL LEAVE YOU WITH TWO ANTENNAS IN ONE SYSTEM. ONE ANTENNA'S TOTAL DIPOLE LENGTH IS 32.8 FEET (16.4 FEET ON EACH DIPOLE LEG) OR A 20 METER DIPOLE, AND THE OTHER IS THE 40 METER DIPOLE AS THE WIRE IN LADDER LINE YOU DIDN'T CLIP WILL NOW RUN THE ENTIRE LENGTH OF EACH SIDE, CONTINUE AROUND THE END INSULATORS AND CONTINUE IN A HAIRPIN RUN AROUND TO THE OTHER (LOWER) SIDE OF THE LADDER LINE ON THAT SAME SIDE MAKING A LENGTH OF ABOUT 66.8 FEET TOTAL OR 33.4 FEET ON EACH LEG (LESS THAN THE MATH OF JUST ADDING AND SUBTRACTING BECAUSE YOU LOST LENGTH WHEN YOU SOLDERED THE WIRES THAT ARE IN THE END CONNECTORS) THIS IS FINE FOR A 40 METER DIPOLE.

THERE IS JUST A LITTLE INTERACTION WITH THE TWO ANTENNAS SO CLOSE TOGETHER. IF YOU WISH TO BE REALLY FUSSY, YOU MAY WANT TO DO THE WIRE CLIP ACTION AND CHECK THE TUNING USING AN ANTENNA ANALYZER. IF THIS IS THE CASE, DO NOT CLIP OUT A 1/4 INCH PIECE YET, JUST CLIP THE WIRE, MEASURE THE SWR WITH THE ANTENNA HUNG AND MAKE ANY CORRECTIONS (DO THIS BY RESOLDERING THE CUT YOU MADE AND MAKE ANOTHER CUT DEPENDING UPON THE ANTENNA'S RESONANT FREQUENCY). ALTHOUGH THIS ANTENNA IS NOT AS EFFICIENT ON 40 METERS AS A DIPOLE STRUNG OUT INSTEAD OF FOLDED, I HAVE USED THIS ANTENNA ON MANY OUTINGS WITH GREAT RESULTS AND IT IS MORE CONVIENT TO PUT UP OR STORE. YOU CAN EASILY COIL IT UP AND STORE IN YOUR BACK PACK. IT CAN BE PUT UP AS A DIPOLE, SLOPER OR INVERTED "V". MAKE SURE YOU HAVE NON-CONDUCTING CORD TO HANG IT UP. AND BY THE WAY, SINCE THE 40 METER SECTION LOOPS AROUND, ALL YOU NEED IS 52 FEET BETWEEN TREES TO HANG THIS ANTENNA AS A DIPOLE!!!



**LADDER LINE ANTENNA
COILED UP FOR STORING IN A BACK
PACK SO IT CAN BE USED WHILE HIKING
OR CAMPING**

**ALL DESIGNS COPYRIGHTED
BY W2IK - BOB HEJL
MY NOT BE USED WITHOUT
AUTHOR CREDIT**

VISIT A FEW OF MY OTHER WEB PAGES BY CLICKING ON EACH TITLE BELOW

[EMERGENCY HAM INFO](#)

[HAM RADIO FOR KIDS](#)

[W2IK'S BEACON HOMEPAGE](#)

[W2IK'S EMERGENCY COMMUNICATIONS GUIDE](#)

[HAM RADIO AMONG THE ALLIGATORS \(NEW\)](#)

[HAM RADIO AND THE WORLD TRADE CENTER DISASTER](#)

[THE AFTERMATH OF WTC 9/11 - MY LIFE IN A SHELTER](#)

[OVERLOOKED ANTENNA CONSTRUCTION POINTS](#)

[HAM RADIO CAN BE HAZARDOUS
TO YOUR HEALTH - NEW](#)

["FAMILY PREPAREDNESS" -NEW](#)

["IS YOUR COMMUNICATIONS GROUP VULNERABLE?"](#)

page created with [Easy Designer](#)

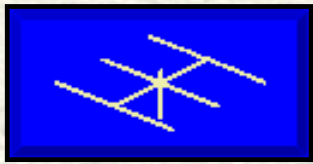

Not Everything Good is New: The Expanded Lazy-H



L. B. Cebik, W4RNL

Very effective antennas do not have to be exceptionally large or expensive. The latest designs and construction methods have their advantages--and also their costs. They tend to obscure some older designs of high merit as we forget to remember them.

Rotatable antennas are very effective, but for those unwilling or unable to put a tower, rotator, and sizable aluminum structure in the air, fixed position wire arrays can provide excellent gain. Most designs are bi-directional, but the side rejection is often sufficient to eliminate most QRM. If we have the trees or the poles to support the ends, and if we take the trouble to align the antenna in the most favorable directions for our intended operation, a wire array can work wonders. For example, a great circle drawn through my QTH in Tennessee with one end in VK-ZL land will have its other end in Europe. A bi-directional array might be just the ticket for much of my operating.

Many broadside arrays are flat-tops--that is, they require at least two wires with considerable horizontal space between them. For most purposes, I would need 4 supports. However, a design that has been around since wire became popular is the Lazy-H, a vertical stack of two wires fed in phase. The standard Lazy-H consisted of two 1 wl wires spaced 1/2 wl apart and elevated so that the lower wire was 1/2 wl above ground.

John Schultz, W2EEY, wrote in the November, 1968, CQ of the "Expanded Lazy-H Antenna." Bill Orr, W6SAI, recalled this antenna in one of his many columns during the 1980s. Another 15 years has gone by, so let's recall this effective array one more time. The key to expanding the Lazy-H is to increase both the horizontal and vertical dimensions by just a little bit.

If we increase the wire lengths from 1 wl to 1.25 wl, we have stacked extended double Zepps in our Lazy-H. The effect is to give us a bit more gain per wire and a significant amount more from the pair. Then, if we increase the spacing from 1/2 wl to 5/8 wl, we achieve approximately the maximum stacked gain possible with two simple wires.

Now, let's build one of these expanded Lazy-Hs for 10 meters.

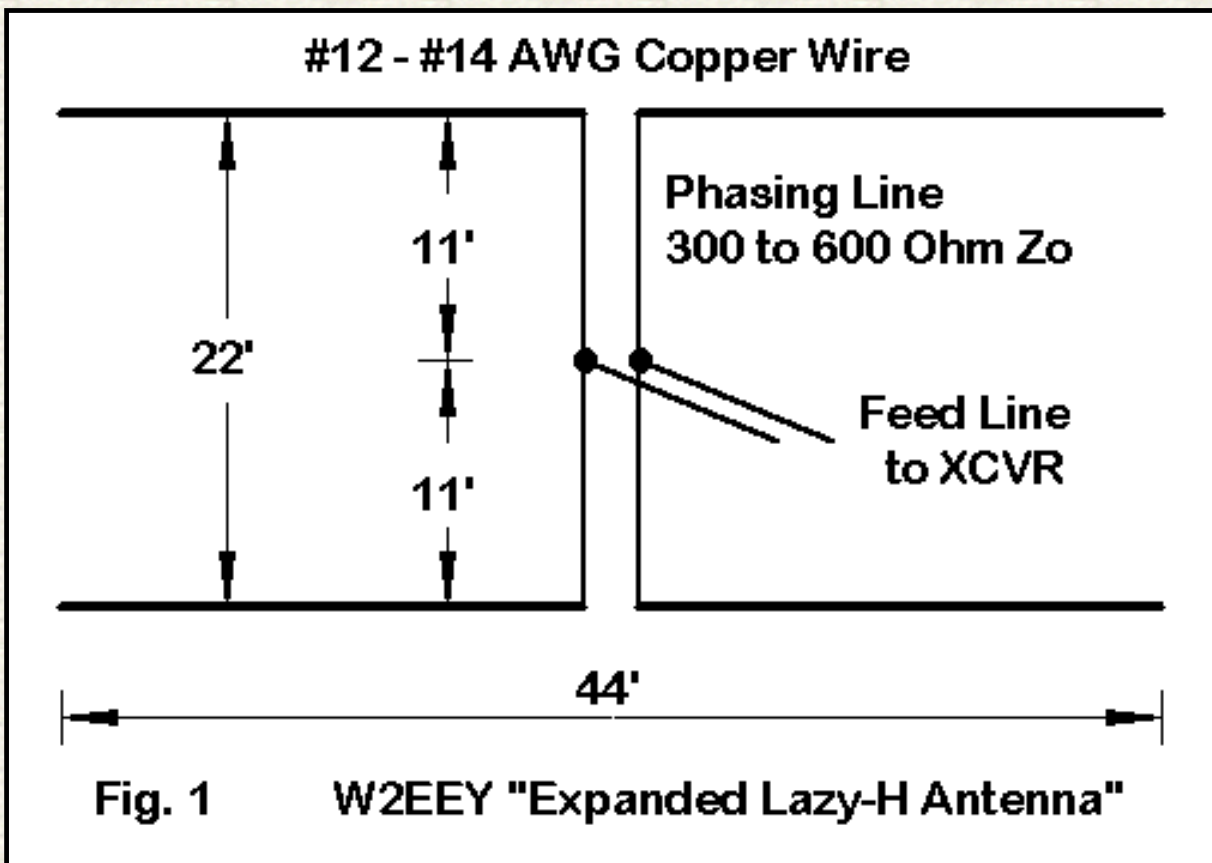

Fig. 1 shows the antenna outline. For 10 meters, a length of 44' per wire is satisfactory and not critical: 40' to 50' will work, but the pattern on 10 meter begins to split up as we lengthen the antenna too far beyond 1.25 WL. Vertical spacing between the two wires need not be too fussy, but the recommended 22' gives us not only 5/8 wl at 10 meters but a usable spacing at other frequencies.

The recommended minimum of 1/2 wl at 10 meters is a bit low for optimal performance. I would recommend that a lower-wire height of about 44' be used, which places the top wire at 66' up. Lower heights will reduce the gain and elevate the TO angle from the figures I shall present as we think about this simple array.

The mechanical beauty of the Lazy-H design is that it requires only two supports--although fairly tall ones. The electrical beauty of the antenna is that it provides excellent bi-directional performance from 10 meters through at least 17 meters, with good performance down to 30 meters. It can also be pressed into service on 40 meters without much difficulty.

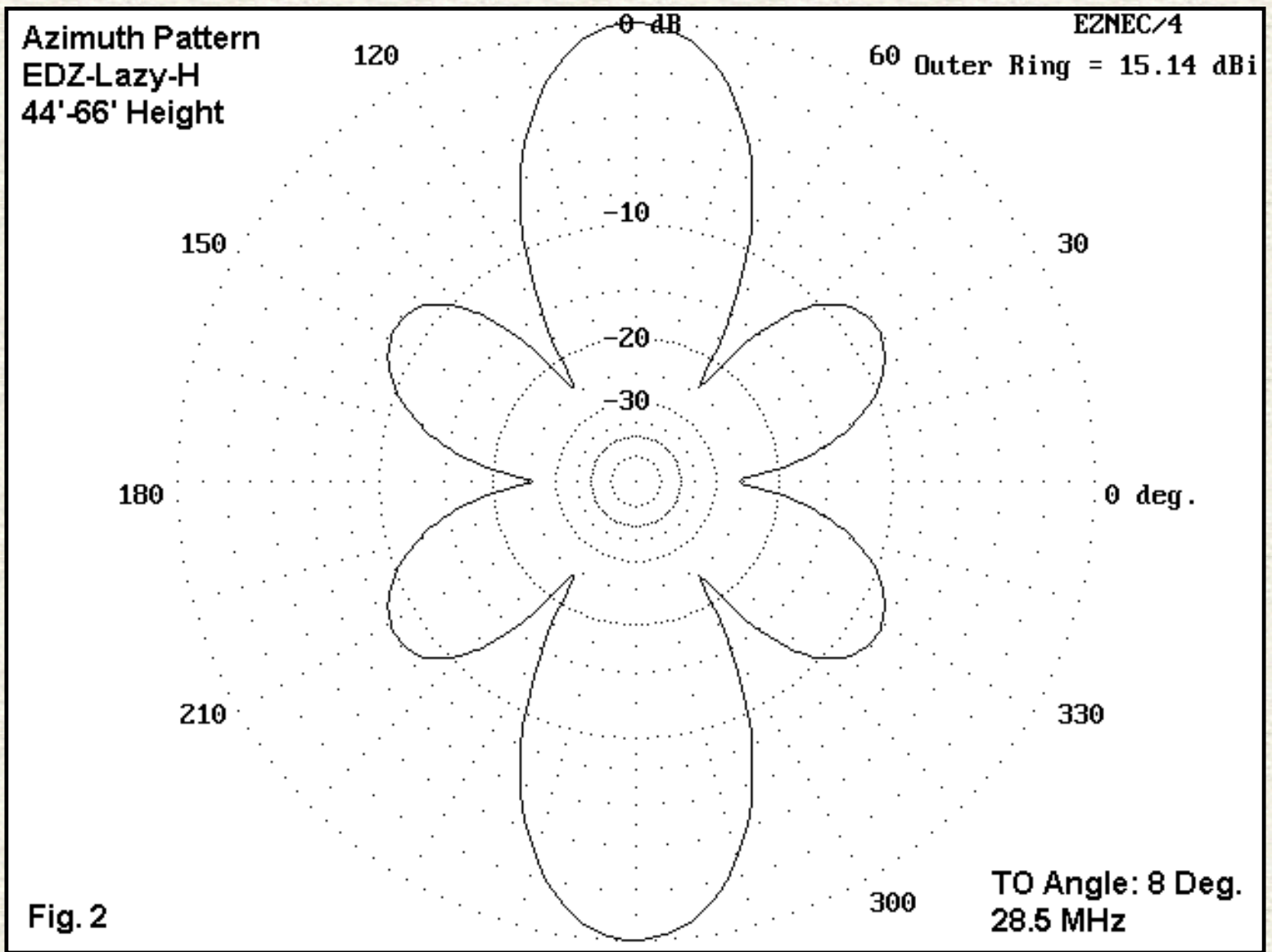
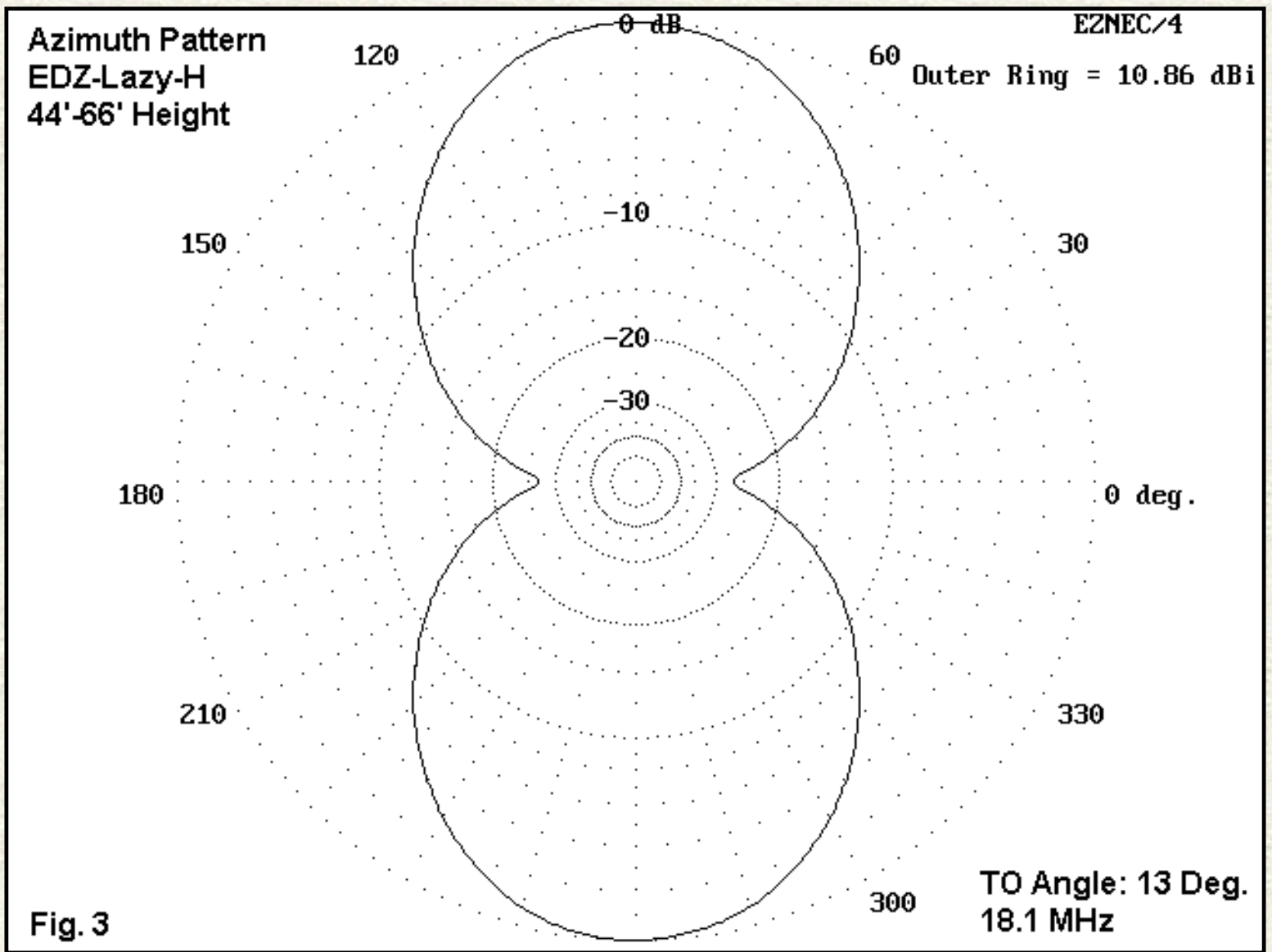

Fig. 2 shows the azimuth pattern of the antenna on 10 meters at an elevation angle of 8 degrees. The phase-fed array still retains the EDZ "ears." These ears are the beginnings of the multi-lobe pattern that emerges as the antenna wire length grows toward the 1.5 wl mark.

On all bands below 10 meters, the length of the antenna is under the EDZ mark, so the pattern is bi-directional with single lobes each way. In fact, at 15 meters, the antenna becomes a standard Lazy-H: two 1 wl wires spaced 1/2 wl apart vertically.



In **Fig. 3**, we see the 17-meter pattern at its elevation angle of maximum radiation of 13 degrees. As the tables below will show, the lobes become wider as we reduce frequency and narrower as we increase frequency.

For a more systematic view of anticipated performance on all of the possible bands on which we might use this one Lazy-H, here is a table of modeled performance over average ground, with the lower wire 44' up. The table lists the usual gain and TO angle data, but also adds numbers for the vertical and horizontal beamwidths between the -3 dB (half-power) points. This data is useful in determining the azimuth coverage of the antenna in each direction and in estimating the elevation angles to catch the skip for varying circumstances.

| Freq MHz | Max. Gain dBi | TO angle degrees | Vert. BW degrees | Hor. BW degrees |
|-------------|------------------|---------------------|---------------------|--------------------|
| 28.5 | 15.1 | 8 | 9 | 31 |
| 24.9 | 14.6 | 10 | 11 | 41 |
| 21.2 | 12.5 | 11 | 12 | 52 |
| 18.1 | 10.9 | 13 | 14 | 61 |

| | | | | |
|-------|-----|----|----|----|
| 14.15 | 9.0 | 17 | 18 | 73 |
| 10.1 | 8.1 | 24 | 27 | 85 |
| 7.15 | 6.4 | 33 | 44 | 99 |

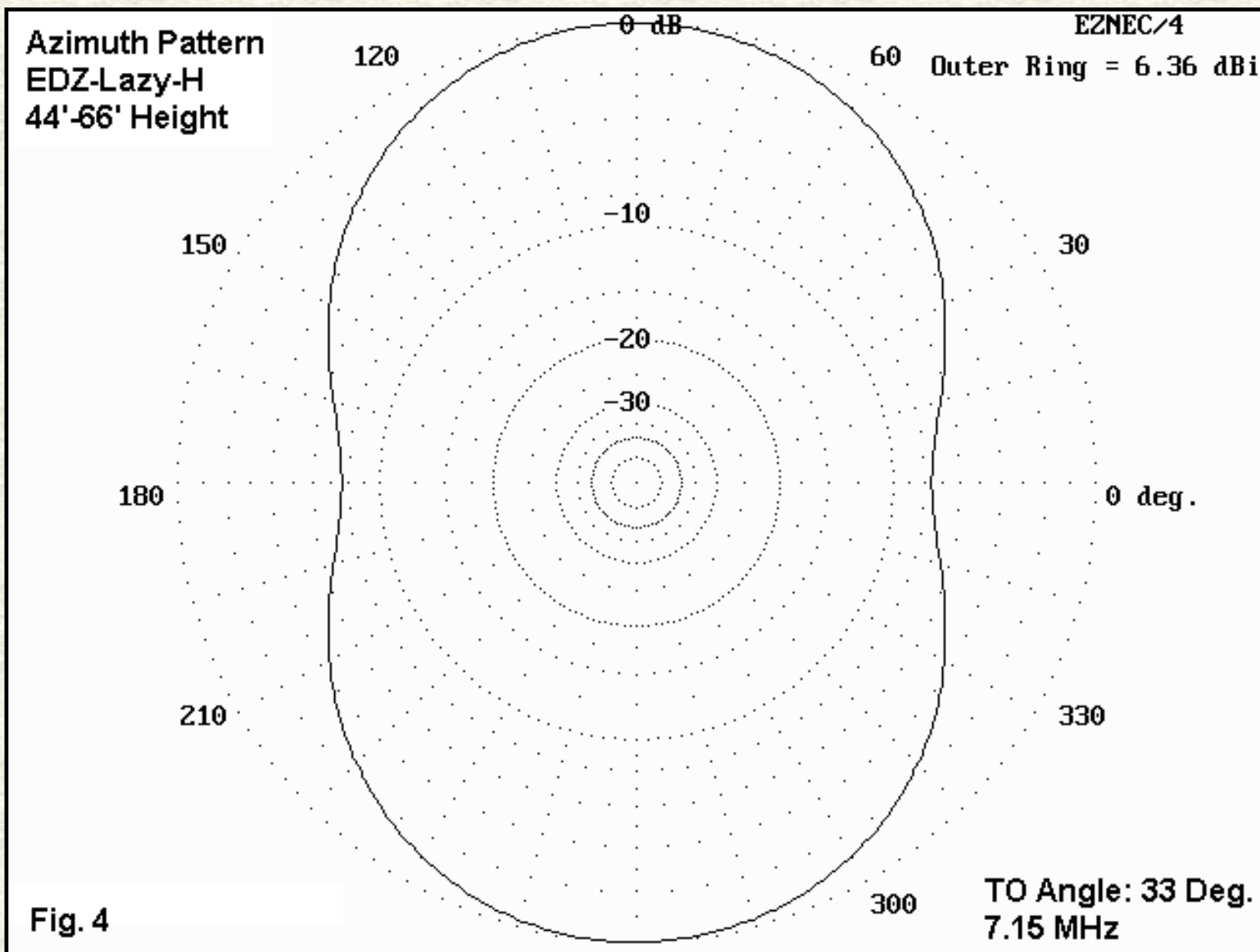

By the time the antenna's operating frequency is lowered to 40 meters, the pattern becomes a broad oval with a fairly high TO angle, as shown in **Fig. 4**. However, sufficient radiation occurs at lower angles to make it usable for general purpose communications on that band.

How good is the antenna's performance? I could use any number of comparators here, but the simplest would be a single 44' wire placed 66' up in height, the same height as the top wire of the array. The usefulness of this comparison is that it helps reveal something of the array's characteristics.

| Freq MHz | Max. Gain dBi | TO angle degrees | Feedpoint Z R +/- jX Ohms |
|-------------|------------------|---------------------|------------------------------|
| 28.5 | 10.5 | 7 | 150 - j 695 |
| 24.9 | 10.4 | 8 | 620 - j1700 |
| 21.2 | 9.0 | 10 | 4200 + j 850 |

| | | | |
|-------|------|-----|-------------|
| 18.1 | 8.6 | 12 | 835 + j1560 |
| 14.15 | 7.7 | 15 | 190 + j 490 |
| 10.1 | 7.6 | 20* | 56 - j 105 |
| 7.15 | 7.0* | 29* | 24 - j 600 |

The starred gain entry for 40 meters indicates that the single wire at this frequency shows more gain than the array (by about 0.6 dB). In the TO angle column, the starred entries indicate that the single wire shows a significantly lower angle than shown for the array. Both phenomena are related. The array elevation angle of maximum radiation is a composite from radiation from both wires, with the lower wire radiation raising the angle of the final composite pattern. The difference is slight until the very lowest bands on which we might press this antenna into service. On 40 meters, the lower wire is just over 1/4 wl above ground, so that it raises the overall pattern angle of the array by a goodly amount and provides slightly less gain than the single wire that is about 1/2 wl up.

From 20 meters on up, the Expanded Lazy-H shows good gain over a single wire. The benefits increase the higher one goes in frequency, up to the break-up of the pattern when the wires are longer than 1.25 wl. It is certainly possible to scale the antenna for maximum benefits at a lower frequency, but that lower frequency of maximum gain will become the highest frequency at which one can use the array and still have a bi-directional pattern with a single main lobe off each side of the wires.

The single 44' wire also shows a wide variation in feedpoint impedance according to the length of the wire. The 10-meter value is typical for an EDZ. The 15-meter value is also typical, but of a 1 wl center-fed wire. Parallel feeders and a highly competent antenna tuner would be needed for this antenna. However, careful analysis of the impedance excursions along the chosen feedline can minimize the chances that the tuner antenna terminals will see either a resistance or a reactance value outside its range of adjustment.

So far, I have given no figures for the feedpoint impedance of the Expanded Lazy-H. The two elements in Fig. 1 are fed in phase by the simple expedient of using equal lengths (11') of line to a center point to which we attach the parallel feeders going to the antenna tuner. There are two controllable variables that will affect the feedpoint impedance at the junction with the main line to the shack. One is the length of the lines, which we have set at 11' each. The other is the characteristic impedance and velocity factor of the phasing lines. I shall not here explore other phasing line lengths, but instead shall show some anticipated feedpoint impedances for each band using three different phasing lines. One will be a 450-Ohm, 0.95 VF line, typical of windowed vinyl-covered lines. Another will be 300-Ohm, 0.8 VF line, typical of good quality TV line. The third will be 600-Ohm, 1.0 VF line, which might be bought or built from wire and spacers.

| Freq MHz | Feedpoint Impedance (R +/- jX Ohms) | | |
|-------------|-------------------------------------|-------------------|-------------------|
| | 450-Ohm 0.95 VF | 300-Ohm 0.8 VF | 600-Ohm 1.0 VF |
| 28.5 | 65 + j 425 | 115 + j 570 | 105 + j 610 |
| 24.9 | 17 + j 115* | 11 + j 140* | 30 + j 140 |
| 21.2 | 22 - j 15* | 10 + j 38* | 40 - j 50 |
| 18.1 | 45 - j 125 | 16 - j 26* | 90 - j 230 |
| 14.15 | 385 - j 395 | 75 - j 150 | 1050 - j 350 |
| 10.1 | 50 + j 105 | 40 + j 65 | 50 + j 155 |
| 7.15 | 10 - j 95* | 6 - j 80* | 13 - j 90* |

Starred entries represent very low resistive components to the feedpoint impedance which might present larger excursions along whatever line is chosen as the main feedline to the shack. Note that the starred entries are fewest with the 600-Ohm phasing line. Once more, it is worth noting that these numbers are derived for general guidance from models. Variations will emerge from the actual construction of the antenna and from conditions and clutter at the antenna site.

One question that almost always emerges with respect to comparing the single wire and the array gain figures for 10 meters is this: how can the array deliver over 4.5 dB gain over the single wire? The answer is straightforward if we compare elevation patterns for the two antennas. **Fig. 5** tells the tale.

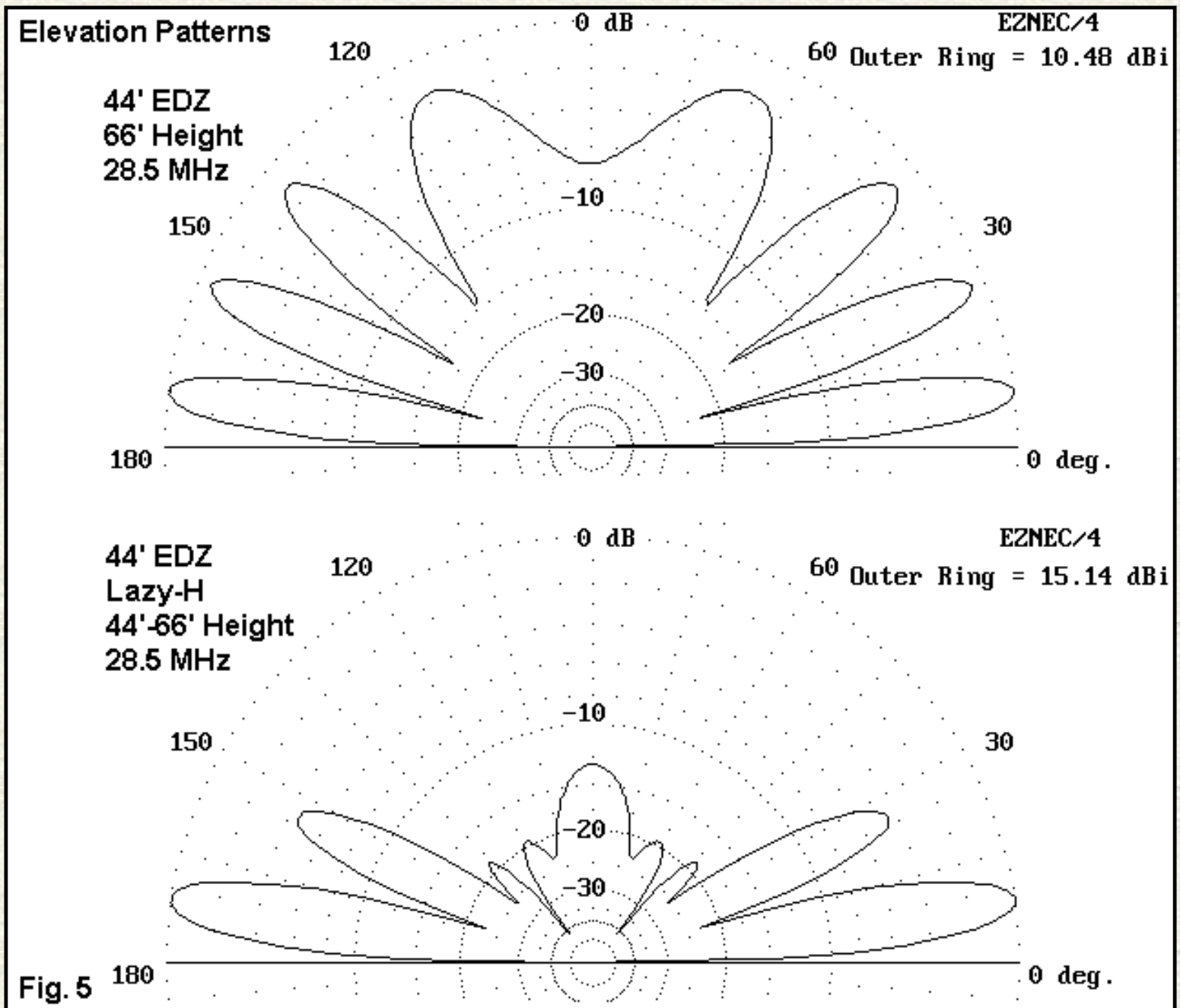

Like any single-wire antenna, the EDZ at 66' on 10 meters shows an array of nearly equal-strength vertical lobes: 4 to be exact. In contrast, the upper lobes of the Expanded Lazy-H are suppressed leaving a single dominant lobe and a secondary lobe well over 4 dB weaker. All other lobes are down by 12 dB or more.

The array tends to waste far less power at very high angles of radiation compared to the single wire. This comparative pattern, with variations, tends to hold true down through 20 meters.

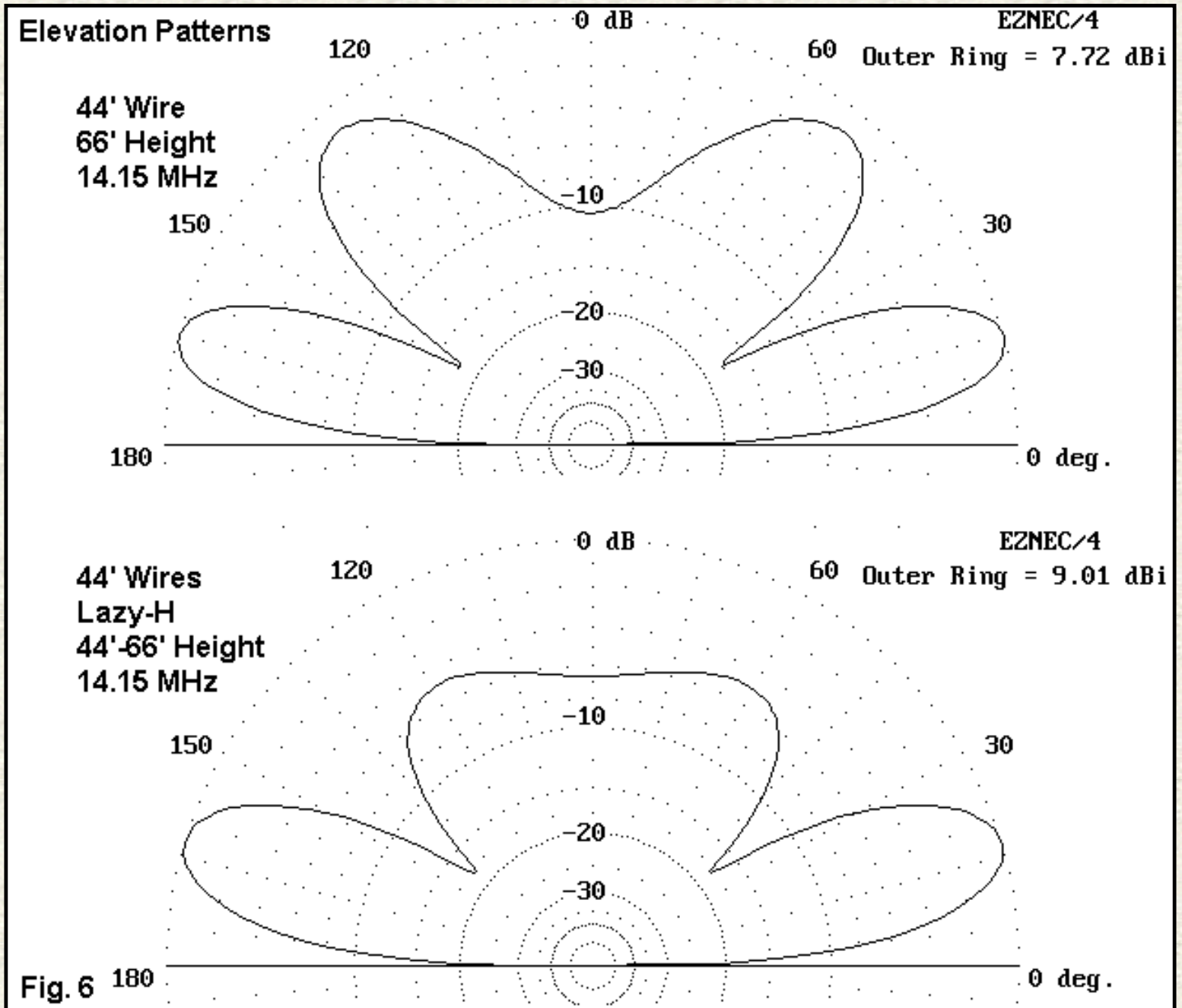

On 20, the effect is less pronounced but still easily measured, as shown in **Fig. 6**. The area enclosed by the upper lobes of the single wire at the top of the figure is distinctly greater by a considerable margin than the area enclosed by the upper lobe (barely discernible as a double lobe) of the array. The difference in area (assuming that the azimuth patterns are comparable, as they happen to be in this case) is a rough measure of the added power appearing in the lower lobes. In this case, that additional power shows up not only in the maximum gain, but as well in the vertical beamwidth. The phased feeding of vertically stacked horizontal wires has benefits hard to match in a typical flat-top wire array.

Along side the benefits come some limitations. The Lazy-H requires a pair of tall supports and is suited to the antenna farm with more tall trees than money. It is possible to lay out more than one of these

inexpensive antennas in order to cover additional regions along the horizon. It is likely that no special treatment will be needed to detune unused arrays to prevent them from altering the pattern of the array in use. Either leaving the shack end of the unused feedline open or shorting it will introduce to the wire feedpoints sufficient reactance to detune the wires. However, this is a facet of multiple array installation that the builder should keep in mind. Sometimes Murphy dictates that nothing will work to prevent interaction short of greater physical separation of the arrays.

The Expanded Lazy-H is an outstanding bi-directional array for 10 meters in the design given here. Its performance holds up well down through 20 meters, and we can press it into service on lower bands. It takes up very little room horizontally in the yard, although a couple of optimally spaced tall trees certainly can aid the installation process. The wires for the elements and the phasing lines, as well as the feedline to the shack and the UV-resistant support ropes, are certainly inexpensive compared to the cost of a tower, rotator, coax, and commercial aluminum antenna. It is a design worth recollecting every 15 years or so just to make sure that we do not forget it.

Can the extended Lazy-H be converted into a directional beam for some or all of the bands that it covers? To find out--at least in principle--see ["Curtains for the Extended Lazy-H."](#)

Updated 4-5-1999; 04-15-2003. © L. B. Cebik, W4RNL. This item first appeared in AntenneX, Mar., 1999. Data may be used for personal purposes, but may not be reproduced for publication in print or any other medium without permission of the author.



[Return to Amateur Radio Page](#)



Click here for more information!

Find on this site...

Site Index

•Exams Search site: Call sign search:
 •Clubs
 •Hamfests
 •Addresses

ARRL Member Login...

Username: Password:

[Register](#)

Quick Links...

•Join or Renew
 •Catalog & Store
 •ARRL Courses
 •Classifieds
 •Getting Started

[Operating Activities](#) [Licensing](#) [News/Bulletins](#) [Services](#) [Educational](#) [Public Service](#) [Support](#) [Donate to ARRL](#) [ARRL Info](#) [Text-only/Printable](#)

Previous: [Ham Radio Aids Rescue on the High Seas](#)

Next: [ISS Expedition 2 Crew Tries Out Ham Gear; School QSOs Set](#)

**ARRL Products:
 Pins, Patches, Maps, Gift Ideas & Supplies...**
[\(More\)](#)



MINILOG -- Pocket-size logbook.



QST Binder--Large
 -- 8.5" x 11" for QST 1976 and

after.



Life Membership Patch - round --

Round embroidered patch, 3-inches. Red, white, black and gold threads.



Flag Patch -- Cloth patch with ARRL flag design.



H. P. Maxim Mug (photo) -- Ceramic

coffee mug (10 oz) with photo of ARRL Founding President, Hiram Percy Maxim, W1AW.

In Brief

March 22, 2001

(In alphabetical order)

[AMSAT-NA 2001 Annual Symposium issues call for papers;](#)
[Array Solutions acquires RF Applications marketing rights;](#)
[California ARES team gets into a stink--and the nose knows!](#)
[Crowd welcomes HRO-Anaheim back to original location;](#)
[Dayton Contest Dinner tickets on sale; EMCOMM 2001 is March 31;](#)
[FCC chairman touts "enforcement model";](#)
[First QSO reported between ionic fluid antennas;](#)
[MOBMU wolfed in Massachusetts;](#)
[National Weather Service gets a MARS station;](#)
[New address for VK4 incoming QSL bureau;](#)
[Pacific Section to hold first-ever section convention;](#)
[SETI@Home tallies 593,000 computing years;](#)
[Southeastern VHF Society Conference set;](#)
[TV program on HPM scheduled to air;](#)
[Visalia International DX Convention Contest Dinner set](#)



AMSAT-NA 2001 Annual Symposium issues call for papers: The first call for papers has been issued for the AMSAT-NA 2001 Annual

Symposium, set for October 5-6 in Atlanta, Georgia. Papers may be presented by the author during the symposium or simply offered for inclusion in the *Symposium Proceedings*. Subject matter should be of general interest to Amateur Radio operators involved in satellite communications. Suggested topics include operating

techniques, antenna design and construction, spacecraft design and construction, current mission status, proposed satellite missions, telemetry acquisition and relay, satellite microwave projects, etc. An outline abstract of the proposed paper should be submitted as soon as possible. The final date for abstracts is June 30, 2001. Completed papers must be received no later than August 15. Electronic submittal is preferred. The format must be either *MS Word*-compatible or plain text. For security purposes, Symposium Chairman Steve Diggs, W4EPI, asks authors to condense the document file and send it as an e-mail attachment to w4epi@amsat.org.--*AMSAT News Service*

Array Solutions acquires RF Applications marketing rights: Array Solutions has acquired the exclusive marketing rights to RF Applications VFD, P-3000 and P-5000 wattmeters and the IBS-1 Intelligent Band Switch. RF Applications will continue to manufacture and support these products and will honor all existing warranties. "We are excited that Array Solutions has elected to add our products to their product line," said RF Applications President Bruce R. Knox, W8GN. "We feel that our products need better exposure to the marketplace, and Array Solutions' market presence is a perfect answer to that need." Array Solutions President Jay Terleski, WX0B, said the RF Applications' power-measurement devices will be an important part of the company's vertical array-phasing products it's introducing this year. RF Applications has announced that it no longer will manufacture its P-2000A, P-5000A and P-2000CW wattmeters. The WinWatt will continue to be marketed and sold exclusively by RF Applications.



California ARES team gets into a stink--and the nose knows! (This is not a story for the squeamish, so if you're of a sensitive nature or just ate, perhaps you should just skip to the next item--*Ed*.) Amateur Radio Emergency Service members in Ventura County, California, recently got into a stink--quite literally. As Ventura County ARES District Emergency Coordinator and RACES Radio Officer Dave Gilmore, AA6VH, explains, this story may sound like just so much horse manure--and you'd be right. Three and a quarter acres of it, 15 feet deep, and all on fire. Manure from an area race track is mixed with hay and used to compost mushrooms. The compost piles have been known to spontaneously combust, and that's what happened recently. "The smoke and smell even traveled to Los Angeles County to our west and south, and to Santa Barbara County to our north, Gilmore said. Fire officials asked Ventura County ARES/RACES to help determine the direction of the smoke cloud. "Unfortunately, it was foggy and hazy, making it hard to determine where the smoke ended and the haze began," Gilmore said. "The only way to tell was by sniffing the air." Hams were sent out to sniff various areas and report back. Gilmore says that those on "sniff patrol" periodically were forced to refresh their olfactory capabilities. "After a couple of whiffs, most people get used to even foul odors and can mistakenly believe the odors have gone when they actually have not," Gilmore explained. In addition to fire officials in two jurisdictions, air pollution and health officials got into the act. For a variety of very good reasons, it was decided the best way to put out the fire was to cart off the burning manure to a nearby field to disperse and extinguish. "Unfortunately the dispersal and movement of the fuel would cause a temporary increase in the amount of smoke produced by the fire," Gilmore said. By the second and third days, ARES/RACES members were stationed to report when the smoke and smell became intolerable, so that operations could temporarily halt until the smoke level decreased. After the weather cleared, one operator was stationed atop a nearby hill to observe the smoke trail and direct the operators around as the smoke plume shifted. By the third day, Gilmore said, enough of the compost had been moved to decrease the smoke level to the point where it no longer posed a problem.--*Dave Gilmore, AA6VH*

Crowd welcomes HRO-Anaheim back to original location: A huge crowd was on hand to



HRO Vice President Robert (left) and President (and Robert's father) Bob Ferrero, W6KR and W6RJ, flank HRO-Anaheim Manager Janet Margelli, KL7MF, as she cuts the ceremonial ribbon to signify the return of HRO to its original location at 933 North Euclid in Anaheim. [K7JA Photo]

celebrate the return of Ham Radio Outlet to its original location at 933 North Euclid in Anaheim, California. That location was destroyed by fire in January 2000 and the store has been in nearby temporary quarters since then. Representatives from Alinco, ARRL, ICOM, Kenwood, NCG, Pryme, RF Parts Co, Sangean, US Tower, and Yaesu were busy showing off their latest wares, Gordon West Radio School handed out Amateur Radio leaflets to passers by. HRO-Anaheim is the largest Amateur Radio store in the Los Angeles area. Ham Radio Outlet has 12 stores throughout the US, five in California. "It was great to welcome so many of our local customers to our Grand Re-Opening event," said HRO-Anaheim Manager Janet Margelli, KL7MF. "Their support through the long and arduous rebuilding process has been greatly appreciated by all of us in the HRO organization."

Dayton Contest Dinner tickets on sale: The North Coast Contesters have announced that tickets for the ninth annual Dayton Contest Dinner now are on sale. Sponsored by *CQ* magazine, the master of ceremonies will be *CQ*

Contest Editor John Dorr, K1AR. Featured speaker will be WRTC-2000 Chairman Tine Brajnik, S50A. The names of 2001 Contest Hall of Fame inductees will be announced by the *CQ Contest* Editor Bob Cox, K3EST. The dinner will be held Saturday, May 19, 6:30 PM, in the Van Cleve Ballroom, Crowne Plaza Hotel, Fifth and Jefferson streets (next to the Convention Center), in downtown Dayton. Tickets are \$30. Seating is limited to 300, no reserved seats. For tickets and additional information, contact Craig Clark, W1JCC, Radio Bookstore, PO Box 209, Rindge, NH 03461; Place orders by telephone weekdays 10 AM to 6 PM Eastern, 800-457-7373 (toll-free) or 603-899-6957, or by FAX 603-899-6826 anytime, or via e-mail to nx1g@top.monad.net. Credit cards are accepted but no CODs. E-mail orders must include charge card, call sign and return address information. Tickets will be sent via first-class US Mail no later than May 8. Deadline for ticket orders is May 7, 2001.

EMCOMM 2001 is March 31: The second annual Emergency Communications Conference will be held Saturday, March 31, 2001, at Bishop Quinn High School in Palo Cedro, near Redding, California. The all-day event begins at 9 AM; registration gets under way at 8 AM. EMCOMM 2001 will include seminars and workshops on topics such as search-and-rescue radio communications, emergency antennas for VHF and HF, choosing batteries and emergency power sources, public relations and working with the media, an overview of the incident command system and SEMS, "mutual aid" practices, and handling formal traffic. The National Weather Service will offer a presentation on SKYWARN. EMCOMM 2001 is sponsored jointly by ARRL Sacramento Valley Section Amateur Radio Emergency Service and the California Office of Emergency Services Auxiliary Communications Service. Anyone interested in volunteer emergency communications is welcome. For more information, visit the Sojourners Net Web site, <http://www.qsl.net/k6soj> or write EMCOMM 2001, c/o D.W. Thorne, K6SOJ, PO Box 16, Macdoel, CA 96058. --Donna Ferguson, N6SVV



FCC chairman touts "enforcement model": Speaking at the CTIA 2001 Wireless show in Las Vegas, Nevada, this week, FCC Chairman Michael Powell said the FCC is rethinking its business model. According to an *Infoworld.com* [report](#) Powell told the gathering that the FCC is "reviewing the optimal organization and structure" with an eye toward a more-responsive FCC. "We are putting increasing emphasis on an enforcement model as opposed to a regulatory model," he said, in order to speed up the FCC's decision-making process. "When you cheat, we'll get you at the back end." Powell also said there's a delicate balance for agencies such as the FCC between fostering innovation but not imposing it.

First QSO reported between ionic fluid antennas: The Live-Wire Group has recorded the first liquid antenna-to-liquid antenna contact on Saint Patrick's Day, March 17--and that's no blarney! The Live-Wire Group currently is experimenting with the liquid antenna concept. Participating in the 17-meter SSB contact were WH2AAT in Orange Park, Florida, and N9ZRT in Green Bay, Wisconsin. Both stations were using 10-foot tall by two-inch wide "columns of ionic fluid" (in this case, concentrated saltwater). Also participating in the QSO was W8ZU in Glen Rock, Pennsylvania, who was using a conventional antenna. Members of the Live-Wire Group have been experimenting with the Ionic Fluid Antennas (IFAs) for more than six months, and they report excellent results on the antenna's performance. In most cases the liquid antennas are operated in the vertical position. The RF is fed into the base of the antenna through several three-inch long copper probes that are exposed to the conductive liquid. Live-Wire members continue to experiment with this antenna concept in various forms including liquid dipoles and "pumpable-to-resonant-length" verticals. For more information, contact the Live-Wire Group, <http://www.wireservices.com/livewire.html>.



The 10-foot tall, two-inch diameter IFA antenna on N9ZRT's jeep. [N9ZRT Photo]

M0BMU wolfed in Massachusetts: There's more transatlantic news on the LF front. John Andrews, W1TAG, has successfully copied a WOLF digital signal from Jim Moritz, M0BMU, in the UK. "WOLF has successfully crossed the pond," Andrews exulted in an e-mail to the LF reflector after only a day of listening. Andrews reports receiving "two lines of clean copy" between 0135 and 0200 UTC on March 19 just below 137.5 kHz. Moritz also was pleased. "Many thanks to John for this report and his perseverance," he said. "Now QRSS is not the only way to get across the pond on LF!" QRSS is very slow-speed CW that's been used for LF contacts, while WOLF is a robust digital mode. Moritz reports using a Racal-Decca 5501 Class D power amplifier (1200 W PEP output) with a Racal 9084 signal generator as a synthesizer plus homebrew phase-keying, waveform-generating and amplitude modulator circuits. His antenna is a 40-meter long inverted Vee, 16 meters high in the center and 9 meters off the ground at the ends. He estimated his ERP at 1 W. "I also received a report from ON7YD, who was able to obtain perfect copy on my signal from a short recording," said Moritz, who plans to run additional tests on 137.500 kHz.

National Weather Service gets a MARS station: For unstinting public service by Amateur Radio

there's no better example than the SKYWARN partnership between hams and the National Weather Service. But even that wasn't enough during the 1998 ice storm that knocked out telephone communications across large areas of the Northeastern US for up to several weeks. During that emergency the NWS forecast office in Taunton, Massachusetts, outside Boston, lost contact with the NWS office in Gray, Maine, near Portland. Although dozens of SKYWARN members were activated throughout the long outage, their normal mode is VHF, and Gray is way out of VHF range of Taunton. Thus Taunton was unable to access Gray's vital weather data from northern New England. The Army Military Affiliate Radio System (MARS) and NWS have taken a first step in avoiding such problems in future. Army MARS has licensed a club station at the NWS forecast office at Albany, New York, AAT2CAA. This facility will make it possible for hams with MARS licenses to operate directly from the forecast office when links are needed beyond VHF range. As 1998 proved, it happens. All three MARS services--Army, Air Force, and Navy-Marine Corps--participate in the National Communications System's Shared Resources system linking federal agencies. Even if another NWS office lacks a MARS presence, Albany's traffic can now be relayed either by voice or digital mode through some other federal agency when needed. --*Bill Sexton, N1IN*

New address for VK4 incoming QSL bureau: There's a new address for the incoming VK4 QSL Bureau. It's GPO Box 199, Wavell Heights, 4013 Brisbane, Queensland, Australia.

Pacific Section to hold first-ever section convention: The Pacific Section will hold its first ARRL-sanctioned Pacific Section convention in Honolulu, Hawaii, October 13, 8 AM to 4:30 PM (gates open at 7:30 AM), at Pearl Harbor Community Park, next to the *Arizona* Memorial visitor entrance. Tickets are \$2 each (\$5 for family). All clubs will be given space for a display for the cost of paid admission tickets for all exhibitors. Tables will not be supplied. There will be a picnic area, vendors, flea market, displays, technical talks, amateur exams, and a lunch wagon. Several forums are scheduled, including an ARRL forum with Pacific Division Director Jim Maxwell, W6CF, and others. For more information, visit the [Koolau Amateur Radio Club](#) Web site. --*Bob Schneider, AH6J*

SETI@Home tallies 593,000 computing years: The Search for Extra-Terrestrial Intelligence@home project has completed its 593,000th computing year. SETI@home analyzes radio signals from space for signs of alien signals and uses idle PC time to do the processing. Users install the software on their home computers, where the program works in the background--exploiting the computer's processing power when its owner isn't. SETI@home is able to marshal the power of hundreds of thousands of PCs, processing more information than any supercomputer. The world's most powerful computer, IBM's ASCI White, runs at a speed of 12 teraflops, or 12 trillion floating point operations per second, and costs \$110 million. In contrast, the SETI@home project runs at about 15 teraflops and has cost only \$500,000. No conclusive evidence of extraterrestrial intelligence has been found, but project scientists say there are signals that may prove to be extraterrestrial. The answer, of course, is *out there*. For information on SETI or to obtain a copy of the software, visit the SETI@home site, <http://setiathome.ssl.berkeley.edu/>.



Southeastern VHF Society Conference set: The Southeastern VHF Society holds its fifth annual conference April 20-21 at the Holiday Inn Select-Brentwood, Nashville Tennessee. The program includes presentations by antenna specialist L.B. Cebik, W4RNL, VHF author and *QST* columnist Emil Pocock, W3EP, and EME enthusiast Bob McGraw, K4TAX. For more information, visit the SVHFS Web site, <http://www.svhfs.org/>.

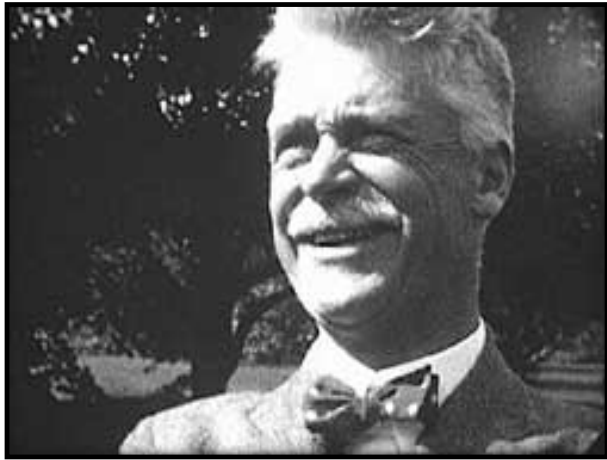

This image of Hiram Percy Maxim is from a 16-mm movie frame taken at George Eastman's home at the introduction of *Kodacolor* movie film in 1927. It's one of the few images that depict Maxim laughing.

TV program on HPM scheduled to air: The life of Hiram Percy Maxim will be profiled in original films and interviews Tuesday, April 3, 7:30 PM, on Boston TV station WCVB-TV5 on the *Chronicle* news magazine. The program deals with recently discovered early films of New England. "Few people today realize that Hiram Percy Maxim was not only the founder of the ARRL but also the founder in 1924 of the Amateur Cinema League," says program producer Art Donahue, KA1GGG. "He chronicled his own life in hundreds of 16-mm movies from 1924 until his death in 1936." Donahue says the films were donated by his daughter, Percy Maxim Lee and his grandson, Hiram Percy Maxim II, to the Hartford, Connecticut, Public Library and Northeast Historic Film in Bucksport, Maine. The program uses this footage along with interviews with Percy Maxim Lee, Perry Williams, W1UED, the ARRL's former Washington, DC, representative, and David Weiss of Northeast Historic Film. Also shown is Maxim Memorial Station W1AW at ARRL Headquarters. The program also

can be seen on many cable systems throughout New England and the Canadian Maritimes.

Visalia International DX Convention contest dinner set: The Third annual International DX Convention contest dinner will take place Friday, April 20, 8 PM, in the Oak and Maple rooms at the Holiday Inn-Visalia, 9000 W Airport Drive, Visalia, California. (Note: This is *not* the main banquet on Saturday evening, and the fee is not included in the convention registration cost.) Prime rib, \$29; chicken princess, \$23. No reserved seats. Tickets are available only from Champion Radio Products, 888-833-3104 (toll-free); Fax 530-758-9062; e-mail dinner@kkn.net; or write Champion Radio Products, 1816 Poplar Ln, Davis, CA 95616. Credit cards, checks and money orders accepted. Credit card users should supply card number, expiration date, and name as it appears on credit card. Deadline to order is Friday, April 13. No tickets will be sold at the door. Tickets will be mailed only to those supplying an SASE with their order; otherwise, pickup at the door. There will be a short program on contesting, guest speaker, and door prizes.--*Bernie McClenny, W3UR*

 Previous: [Ham Radio Aids Rescue on the High Seas](#)

 Next: [ISS Expedition 2 Crew Tries Out Ham Gear; School QSOs Set](#)

Page last modified: 11:12 AM, 26 Mar 2001 ET

Page author: awextra@arrl.org

Copyright © 2001, American Radio Relay League, Inc. All Rights Reserved.

erick@the Net

This is a Java applet which calculates the dimensions and spacings of the elements needed to build a log periodic antenna, given τ , σ and the lower and upper cutoff frequencies.

All lengths and distances are given in meters. Look below for a diagram and a brief explanation describing what are all these numbers and parameters...

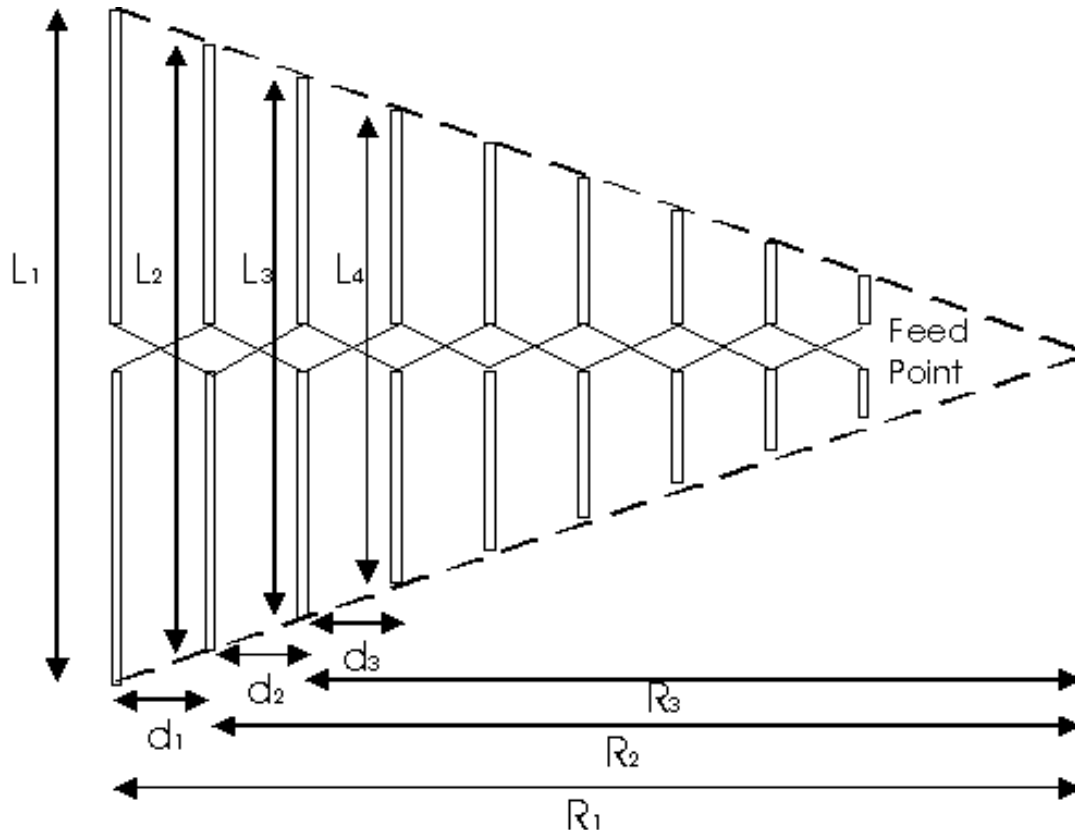

In a nutshell, The log periodic is a broadband antenna whose characteristics vary as a periodic function of the logarithm of the frequency (with period $\text{Log}(\tau)$). As τ approaches unity, we can neglect these response variations and regard the antenna as "frequency independent". σ is a spacing factor, and together with τ , determine the directivity of the antenna.

0.14062

[Back to erick@the net](#)



[web hosting](#) • [domain names](#) • [web design](#)
[online games](#) • [digital cameras](#)

[photo album](#) • [advertising online](#)

Long Wire Antenna

The long wire antenna is used as a field expedient antenna. To construct a long wire antenna you will need the following:

1. WD-1/TT, WD-1A/TT, or WF-16
2. Electrical Tape
3. 400-600 ohms terminating resistor
4. Insulators or material to construct [field expedient insulators](#)
5. Radio set
6. Knife
7. Suspension line
8. Measuring device
9. Compass
10. Signal Operating Instructions (SOI) with frequency and call signs
11. Large open area
12. Fabricated suspension (tree, Camouflage poles, etc.)
13. Calculator (optional)

To erect the antenna follow these steps:

1. Determine azimuth from the transmitting radio to the receiving radio.
2. Determine the length of the wire using the following formula:
 - o **NOTE:For a quarter wave antenna divide 234 (constant) by the operating frequency in this case 9.00 MHz (234/9=26.0 ft.)**
 - o **For a half wave antenna divide 468 (constant) by the operating frequency, in this case 18.00 MHz (468/18.00=26 ft.)**
 - o **For a full wave length antenna divide 936 (constant) by the operating frequency , in this case 8.35 MHz (936/8.35=112 ft.)**
3. Measure and cut the antenna to the desired length
4. Split the WD-1 at the near end, attach one piece to the bottom end of a whip antenna and screw it into the antenna connector on the RT. Connect the piece to a screw on the RT case for a ground.
5. Suspend the antenna antenna using one of the following methods:
 - o Run the antenna wire from the radio set to a nearby tree. Attach the end of the antenna wire to an insulator. Attach a wire or rope from the other end of the insulator to the tree and tie it off.
 - o Use a pole that is at least 9 feet high to suspend the antenna in the same manner. However you will have to use guy ropes to secure the pole.

The antenna is bi-directional. To make a uni-directional antenna place a 600 ohm resistor across the insulator.

- [Table of Contents](#)
 - [Antenna Types](#)
-

Last updated undefined

From: jpd@space.mit.edu (John Doty)
Newsgroups: rec.radio.shortwave
Subject: Re: SWL longwire
Date: 23 Dec 1996 19:49:01 GMT
Organization: MIT Center for Space Research

In article <9612182335114148@mogur.com> len.anderson@mogur.com (Len Anderson) writes:

> TV>> I wonder if a longwire balun would help match the impedance & provide a
> TV>> better signal?

> No, it will (primarily) change only the magnitude of the antenna
> impedance over frequency. Some bands will have more sensitivity than
> other bands. The antenna tuner will take care of that.

Actually, a fixed matching transformer can dramatically reduce the wild swings in antenna efficiency that a coax fed wire antenna exhibits. Let us calculate:

The following graphs are based on a 15 meter vertical antenna, fed at ground level, using a conical approximation. The antenna's characteristic impedance is assumed to be 620 ohms, which is typical for a thin wire. For more on the conical approximation, see Chapter 8 of "Antennas" by John D. Kraus (McGraw-Hill, 1950).

The first graph is for an antenna fed directly from 50 ohm coax. The horizontal axis is the frequency in MHz, the vertical axis is the mismatch loss in dB. The well known "quarter wave" resonances near 5, 15 and 25 MHz are visible as sharp peaks where the mismatch loss closely approaches zero.

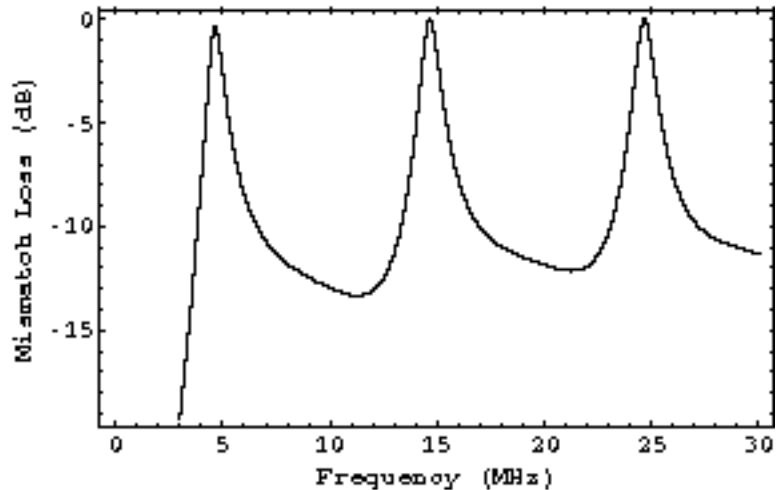

The second graph assumes a matching transformer with a 9:1 impedance ratio at the feedpoint, presenting the antenna with a load resistance of 450 ohms. At most frequencies, the mismatch losses are considerably lower for this case. The variation in the mismatch loss is also reduced:

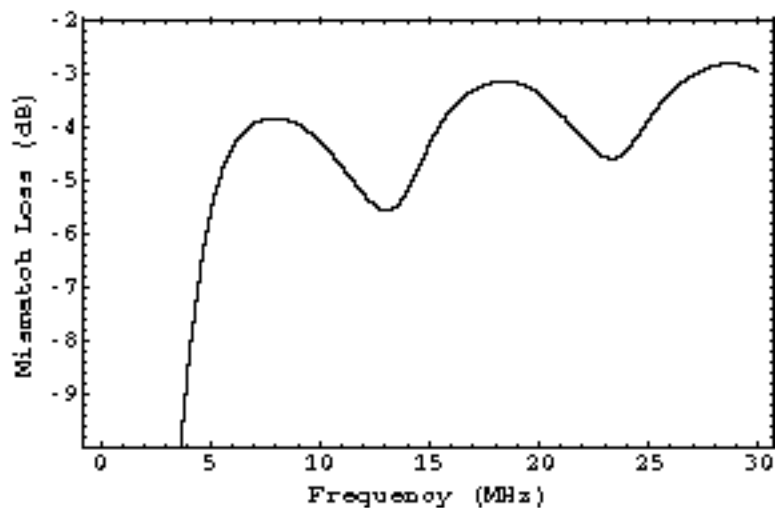

Well, so what? In the absence of interference, the signal to noise ratio is the main determining factor for the audio quality of the signal. The mismatch loss affects both signals and noise, so if the receiver was

noiseless the losses would not affect the signal to noise ratio. Real receivers, however, are not noiseless: if the loss is too high, receiver noise will become dominant, and overall system sensitivity will suffer.

The following results assume cosmic noise of 29 dB above thermal at 10 MHz, declining with increasing frequency at -23 dB per decade. No man made or atmospheric noise is assumed. I assume a receiver noise figure of 10 dB.

First, here is the signal to noise impact of the mismatch losses for a 50 ohm coax feed without a transformer:

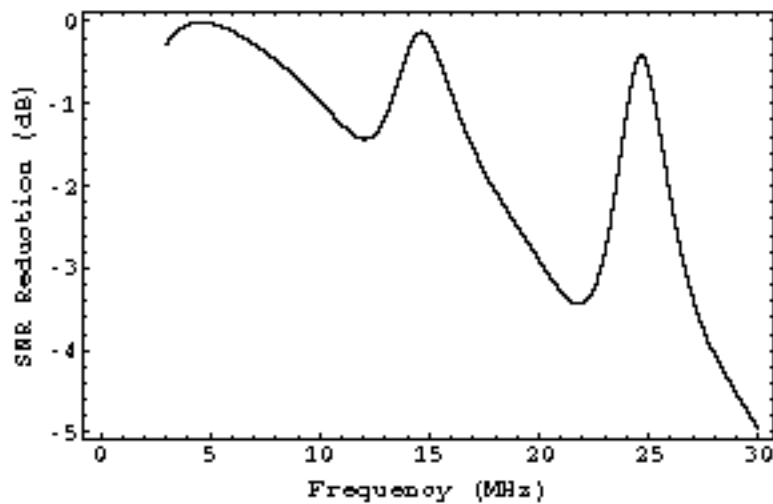

Losses in signal to noise of 3-5 dB are likely to be noticeable. The largest impact is in the quiet bands above 15 MHz.

On the other hand: the loss in signal to noise with a 450 ohm feed is much smaller:

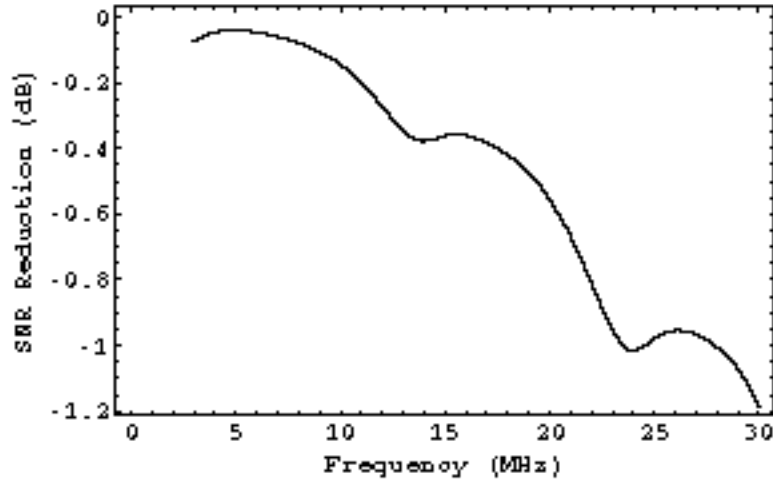

You are unlikely to be able to notice losses in signal to noise in this range.

The results depend on the assumptions. A real longwire isn't usually vertical: this tends to degrade its performance a bit at the low frequency end, while improving it at high frequencies. This is good, because in the model the signal to noise is declining as the frequency increases: the increase in performance cancels part of this.

No man made or atmospheric noise is included. If they are significant, the precision of the match becomes less critical. Man made noise can be significant at any frequency, but atmospheric noise is more significant at the lower frequencies.

A receiver noise figure of 10 dB is mediocre for a solid state receiver or a tube receiver with a triode RF amplifier. Tube receivers with pentode RF stages may be a bit worse than this, and something like a Hallicrafters "Sky Buddy" (no RF stage, pentagrid converter) might have a noise figure >30 dB. The better (smaller) the noise figure, the less you have to worry about matching. Sky Buddy owners will want to tune their antennas very carefully.

I haven't included cable losses here. These are not terribly important unless you're using an ATU at the receiver end. If you are, using a fixed transformer to get the match roughly right at the antenna end will reduce the cable losses, because cable losses increase with increasing SWR.

My own experience concurs with the results of this theoretical analysis (or I wouldn't be writing about it: I'd be trying to figure out what was wrong!). I have experienced "deaf bands" with coax fed antennas lacking matching transformers, but my transformer-fed antennas work well across the HF spectrum (and

even down to longwave). I don't bother with an ATU.

See "[Low Noise Antennas](#)" at "<http://www.anarc.org/naswa/badx/>" for more on matching transformers and on keeping conducted noise from contaminating a "longwire antenna".

John Doty "You can't confuse me, that's my job."
jpd@space.mit.edu

[\[Previous\]](#) | [\[BADX home page\]](#)

Last modified: *March 10, 1998*

E-mail your comments and updates to [Steve Byan](#) <smb@world.std.com>



[\[SITE INDEX \]](#)

LOW NOISE RECEIVE-ONLY COAX-LOOP ANTENNAS

for 160 - 10 meters HF bands



Station WN6F listening post

Last Update: 29 March 2004

After doing battle with locally-generated EMI / RFI for nearly two decades, I decided to do something about it. This antenna's main advantage is that it packs a lot of low-angle directivity into a small package. This makes nulling out many urban noise sources easy while enjoying good medium to high-angle skywave reception.

NEW !! (If you are interested in an easier-to-construct wire-only loop that has better performance, [check out my general-purpose wire-loop page](#)).

The directional small loop is also useful for significantly reducing static-crashes on the lower HF bands at times; this depends on mother nature of course. The larger loop is for 80 meters and the smaller loop is for 40 meters.

The project is described in four parts:

- [General construction and usage](#) (this page)
- [Operational analysis of this small loop](#)
- [Alternate loop winding methods](#)
- [Miscellaneous notes and experiments](#)

They are easy to build, and the only tools you'll need are wire cutters, some coax, and a tuner. You can make them for yourself or friends in a matter of minutes. Part of my design goal was to use a minimum of easily available parts. You won't need a well-stocked junkbox or any exceptional mechanical skills to build this antenna.

Winding the loops out of coax (providing a main antenna loop and an interior coupling loop) in the following fashion is very convenient and has six purposes:

1. The small wavelength outer-conductor loop (at 0.10 or smaller wavelength in circumference) provides the horizontal low-angle bidirectional directivity with deep nulls.
2. The gap in the braid at the top center of the loop allows common-mode reception of signals (both wanted and unwanted) on the outer skin of the loop braid to transition to the inner-skin of the braid. Rotational directivity nulls out the unwanted noise.
3. The current on the inner-skin of the braid now acts like a normal transmission line via the differential-mode to the center conductor.
4. This specially-wound loop acts as it's own balun, which is necessary when using unbalanced coax as the feedline. This helps to ensure that the feedline does not become part of the antenna. If it did, you'd lose much of your directionality, or have very strange nulls.
5. The large amount of distributed capacitance makes the loop somewhat

resistant to unbalance and detuning from hand-body-object capacitance than more traditional balanced wire loops.

6. The larger outer conductor diameter of the braid increases the sensitivity of the loop over that of a small-gauge wire.

Prove it!: Attach a clamp-on ferrite RF cable choke on the feedline and arms of the loop. When chokes are placed anywhere on the arms of the split-braid loop, severe detuning and attenuation takes place. When placed anywhere on the feedline after the loop output, no detuning or attenuation occurs.

HF loops built in this way are typically used for direct wave direction-finding. I'm more interested in using them as near-field noise-nullers to enhance the signal-to-noise ratio of skywave signals. This helps make up for their inherently lower gain than more traditional long wire antennas. A balun-effect is created by the way we wind the antenna back onto the feedline to help prevent common-mode noise ingress and maintain an accurate directional pattern.

2004 update: See below for [smaller TWO-TURN Loops!](#)

I'm using these antennas indoors right next to the operating position to make it easy to rotate and tune. Remote mounting is certainly possible, preferably with an antenna tuner or preamp located near the loop, although in that case I'd advise using a [plain wire loop](#) if you want to keep the tuner near the operating position.

As an example, let's build a single-turn 0.10 wavelength loop for 40 meters:
(it will also function well as a .05 wavelength loop on 80m with retuning)

WHAT YOU'LL NEED:

- For 40 meters, you'll need about 15 feet of coax (loop and some extra length for tuner connection, plus pigtail wrap.) I prefer to use 50-ohm RG-58. For convenience I picked up a 50-foot jumper at Radio Shack (#278-971A) which is already connectorized so I could build a few of them. You could also use 75-

ohm coax without any difficulty. Try to get the lowest capacitance cable that you can find.

- An antenna tuner can be used to tune the loop system to resonance. I've used L-type tuners and T-type tuners without any problems. I'm currently using an MFJ-16010 random-wire tuners which are small and use two SO-239 connectors which makes them easy to hook up and mount to a mast if desired. Note that on 160 meters, you'll need a lot of inductance, and the 16010 model doesn't seem to have enough when used with coax-loops.
- Optional: A 10 dB gain or more preamp can be used to help bring up the signal level. If your receiver has a preamp, and all it seems to do is bring up the noise level along with the signals, you are in for a treat. With this directional antenna, the preamp finally becomes useful in amplifying the signals, and not the noise.

Use the largest coax diameter you find practical. I use RG-58 since it is easier to work with, but the larger conductor size of RG-8 / 11 should perform a little bit better.

LOOP SCHEMATICS:

My best artistic attempts at drawing the schematics.

Click on the images for a larger picture.

(Internet-Explorer users: IE has an option that automatically reduces the size of graphics. If the enlarged schematics look distorted, be sure to view them full-size, typically with F11 Key)

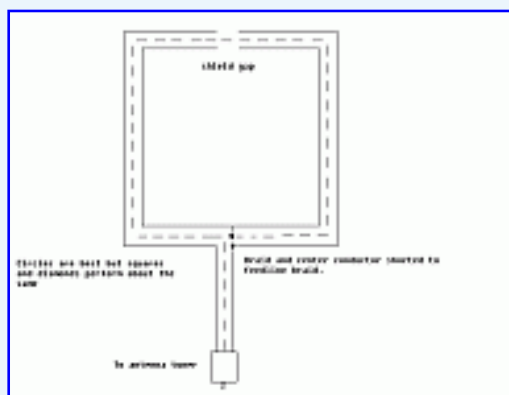

HOW TO MAKE IT:

(Click on any of the images to enlarge them.)



1) First, at one end of the coax, let's short the braid and center conductor together with a pigtail. RG-8 was used to make it easier to see, although I like to use the smaller RG-58 or RG-6. After removing the outer covering, I bunched the braid back a bit to allow me to cut into the inner dielectric and then just pushed it back down when I was done. Take care not to cut or score the inner conductor with the knife, especially when using the smaller cables; when you wrap the pigtail around the braid in a later step, it has a tendency to snap at the cut or score when you wrap it.

(It might be easier to build the loop by following these instructions backwards if you already have a connectorized piece of cable.)

2) We need to create a 1-inch gap in the coax shield. Measure 7 feet from the shorted end, and make a small cut mark on the coax. A half inch on either side of the mark, cut through the outer covering exposing the braid. Then cut the braid out to expose just the inner dielectric. Try not to cut into the inner dielectric as this will mechanically weaken the antenna when you eventually mount it. The photos show some exposed braid at the gap just for clarity, but my antennas just have a clean cut. Note that this is just a true gap, you do not short anything at the gap! (Make sure there aren't any fine strands of shield wire still connected across the gap after you cut it!)



KEY POINT: The gap allows common-mode reception of radiated energy (both wanted and unwanted) on the outer braid skin to transition to differential-mode currents on the inner braid skin, which is coupled to the center conductor via differential-mode. Rotation nulls the unwanted common-mode energy exposed to the arms of the loop.



3) Measure another 7 feet from the center of the gap, and remove about 1 inch of the outer coax covering ONLY. You should just have some exposed braid.



conductor.

4) Take the shorted pigtail end of the coax, and wrap it around the exposed braid from the previous step. This is the weakest point of the loop mechanically. Try not to make a radical bend at the point where the brittle center conductor is immediately shorted to the braid; it has a tendency to break if you do. Wrap at a point just a little bit further down the pigtail to avoid breaking the center

KEY POINT: This finishes the self-forming balun and helps ensure that the unbalanced feedline does not become part of the balanced loop, thereby unbalancing it, and turning the loop into a noisy random wire.

(NOTE: don't be tempted to use an ordinary "tee" connector here. It won't work properly.)

You now have a highly directional low-band 40 meter loop and the rest is a small length of feedline that goes to the input of a tuner. Of course the jumper from the tuner output to the receiver can be any convenient length.



For 160 through 40 meter operation, you can mount the tuner anywhere from 6-inches to 6-feet away from the output of the loop. This allows you some flexibility if you want to keep the tuner on the desk and not on the mast. For smaller single-turn loops on 20 meters and above, try to keep the tuner no more than 6-inches away from the loop output - the closer to the loop output the better.



Note: Here is a very small loop for overall visual reference.

To construct a 20 meter loop, try a loop circumference of 7 feet. The gap is not critical for any band, and can stay at 1 inch. For 80 meters, try a loop circumference length of 27 feet or so. For 20 - 15 meters, try a 3-foot circumference; I'm amazed that this actually works as well as it does.

Note that when we cut loops for 0.10 wavelength, they will also perform well at half their frequency as a 0.05 wavelength, although sensitivity will be down somewhat. The positive tradeoff is that the nulls will be VERY deep at 0.05 wavelength.

Design Your Own!

UPDATE: MAJOR ERROR IN MY EARLIER DESIGNS!

My apologies go to earlier readers of these pages. I incorrectly assumed that since we are using coax as antenna elements, that they would be subject to a cable's velocity factor. Since the loop element is really the outer braid skin, **it is not subject to velocity factor**. Only the inner differential-mode of coax is subject to velocity factor, and NOT the common-mode outer surface conductor of the braid, which is what we are using as the antenna!

My standard formula for calculating the loop circumference for the frequency of interest at 1/10th wavelength *without any VF*, is:

$$(1005 / \text{freq mHz}) * 0.10$$

TUNING NOTES

This formula should get you in the ballpark, although if you can't get a definite peak with your tuner on the lowest frequency of interest, it is likely that the antenna is too long, or the distributed capacitance of the cable used is too high for your tuner to handle. Try using a more advanced tuner, or reduce the loop circumference length.

You can cut a new loop with a cable that has lower capacitance specs, or just make the existing one shorter. Fortunately it is easy to make a pre-cut loop shorter. Let's cut off two feet from the existing loop circumference as an example:

- Unwrap the shorted pigtail from around the exposed braid. Cut away a foot from this arm of the loop and create another shorted pigtail.
- Measure a foot from the center of the old exposed braid, and cut a new 1-inch exposure of braid.

- Wrap the new pigtail around the new exposed braid section and re-shape the antenna into the smaller shape. Tape up or heat-shrink the older exposed braid section.
- Try to be as accurate as possible and strive for balance when re-sizing the loop. Balance is important!

USAGE:

You can create the loop with any shape you want, but circles are best, and squares and diamonds do nearly as well. Triangles, and extreme rectangles don't do as well, but don't let that stop you. The key is to enclose as much area as possible. For mounting, any sort of cross-brace should work, but I've also placed them on the back of non-metallic doors, hung them from ceilings, etc.

Tune the loop-system (loop and feedline) to resonance with the tuner. Since loops are high-q, you should hear a definite peak in the background noise. Better yet, tune to some locally-generated noise and peak on that. As you change each setting of the inductor, rotate the tuner capacitor(s) s-l-o-w-l-y.

The directivity pattern is a bidirectional figure-8 pattern at low angles, with maximum gain in the plane of the loop, and the nulls are broadside to it. It is just the **opposite** of an ordinary dipole. The loop seems progressively more omnidirectional to medium and high skywave angles.

If you want to see the directional azimuth and elevation angles, [check out my general-purpose wire-loop page](#). The patterns are almost exactly the same as compared to these coax-built loops.

You don't have to have the loop perfectly vertical, use whatever angle you need to null the local noise or storm-related static crashes - skywave signals will still be heard well. In one case, I have a noisemaker downstairs, so I had to rotate and tilt the loop at about 45 degrees to null it - it didn't attenuate the desired band signals at all. At times I've been able to track a storm all night and reduce the static crashes, and then sometimes not depending upon how localized the storm is.

You might notice that even though you've nulled out the noise, signal levels on a tuned loop seem to be about 2-to-3 S-units down from a standard 1/2-wave dipole mounted up at least a quarter-wave above ground. This is normal for a *tuned* small

loop given its short wavelength. You can compensate with a preamp, but you might find that with the noise level so low, you won't need one. If your normal antenna isn't mounted up at least a quarter-wavelength, the comparative loss might be even less!

Note: many modern radios that have built-in selectable preamps might have much lower sensitivity with the preamps off than other radios that don't have any preamps at all. This is a good design feature. Accordingly, with radios that have selectable preamps, it is likely you'll want to run with at least the first preamp turned ON.

The important point to remember is that your noise floor will be so much lower than your old noisy antenna that it more than makes up for brute signal strength.

Connector Quality Issues

Make sure your connections are snug. If you lose the ground, you'll end up with a random-wire because you've lost the electrical balance. I mention this because as you insert or remove the connector from the tuner or receiver, when only the center-conductor is making a connection, you'll hear noise or signal level come up a bit. Unfortunately, you will have lost all the directivity that this antenna provides. Keep those connections tight.

A caution about crimped PL-259 connectors: sometimes the crimp is so tight that when you screw them fully into the chassis jacks, they don't actually make good contact with the chassis-connector center conductor. A **VERY GENTLE** squeeze with a pair of pliers on the center-conductor pin will help ensure good physical contact. I've run into this problem a lot with cheaper cables and sometimes it is not immediately apparent because you can still receive signals (poorly) due to capacitive coupling of the center pins.

Another drawback of cheaper connectors is that when you mate the dielectrics of the cable plug and chassis jack together, they sometimes don't allow the shells to make contact, especially if the "teeth" are short. You might only have a very poor shell-to-chassis connection via the rubbing of the cable's screw ring to the shell.

TWO-TURN LOOPS!



To turn a large loop into something more manageable size-wise, try a continuous TWO-TURN loop. Each turn should have a 1-inch gap at the top of the turn, and at the bottom of the turn you attach the exposed braids and shorted pigtail together.

Turn spacing: you might want to put a coax-diameter's width of space between the two turns. I did this by winding one turn on the front of the mast and the other turn on the back.

(Click on any image to enlarge)



For example, my 40 meter single-turn diamond loop has a 14-foot circumference with an approximate 4-foot diameter.



I turned it into a two-turn loop by starting with a new 14-foot length of coax, and depth-winding a second continuous turn around a 2-foot circular diameter instead of a square 4-foot diameter. At the top of the loop are my two turns with the 1-inch gaps at the center. At the bottom output of the loop I made sure the exposed braids and shorted pigtail are connected together. From this point, I left about 6 inches of coax terminated with a PL-259 connector which attaches to my portable MFJ-16010 tuner.

(Note: I recently placed the tuner on the desk with a 3 foot jumper instead since this loop was designed for the lower bands. For smaller single-turn loops designed for 20 meters or higher, the length of feed from the output of the loop to the tuner should not exceed 6 inches - the closer to the output the better.)

Try to make all your measurements, cuts, and braid connections as symmetrical as possible. Making the loop balanced is key to good noise rejection.

Here is how I made it:

- I used a 15 foot length of coax to allow for a short 6-inch run to the tuner and

some left over to make the shorted pigtail.

- Six inches from the end of the connector, make a 1-inch cut around the coax to expose only the braid.
- Measure 3.5 feet from the center of the exposed braid, and cut a 1-inch gap (1/2 inch on both sides of the mark) through the braid to expose the dielectric.
- Measure 3.5 feet from the center of the exposed dielectric, and cut around the coax for 1 inch to expose only the braid. (1/2 inch on both sides of the mark.)
- Measure 3.5 feet from the center of the exposed braid, and cut a 1-inch gap (1/2 inch on both sides of the mark) through the braid to expose the dielectric.
- Measure 3.5 feet from the center of the exposed braid, and short the shield to the center conductor. Leave about 4 extra inches or so of this shorted pigtail.
- Wrap the coax into a two-turn loop with the exposed braids parallel to each other at the bottom, and the exposed dielectric gaps at the top. Use tie-wraps, tape, etc.
- Wrap the shorted pigtail around the centers of the exposed braid sections at the bottom so that all the braids are in contact. Solder or tape together.
- Put the loop on your support, attach your tuner to the connectorized end and enjoy!

The results of this two-turn loop are great! Signal output levels between my single and reduced-area double-turn loops seems about the same.

Casual MF BCB DX'ing and LF

If you bypass the tuner, you might be able to use a loop cut for 80 or 160 meters in an untuned mode for casual MF BCB and LF reception. It is handy to null out the local broadcasters.

With the loop untuned, I've finally heard low-frequency CW beacons. So there IS life down there! For serious use, I'd definitely recommend specialized antennas for these bands, but at least an untuned loop might whet your appetite to go "lowdown".

Other Sources of Info

I am indebted to all the Amateur Radio operators, SWL's, BCB DX'ers, VLF'ers and other experimenters that provide me with information and encouragement with this project. They participate in the **Yahoo!® Loop group** and also on the **rec.radio.amateur.antenna** newsgroup. All errors and misinterpretations belong to me however ...

If you're interested in loops, whether they be shielded, unshielded, magnetic, loopsticks, etc, you can find a great [discussion forum for loop antennas](#) on Yahoo!® by clicking here.

Be sure to [visit the K7ZB site](#) with his pics and nice build of this loop, along with other interesting antenna solutions.

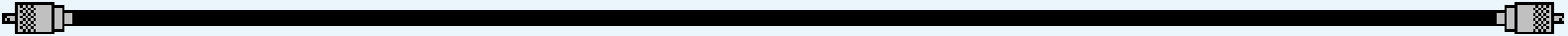

- [General construction and usage](#) (this page)
- [Operational analysis of this small loop](#)
- [Alternate loop winding methods](#)
- [Miscellaneous notes and experiments](#)
- [Easy-To-Build Small Wire Loops!](#)



24887

since 1 June 2003

© 2002-2004 www.greertech.com

LOOP ANTENNAS

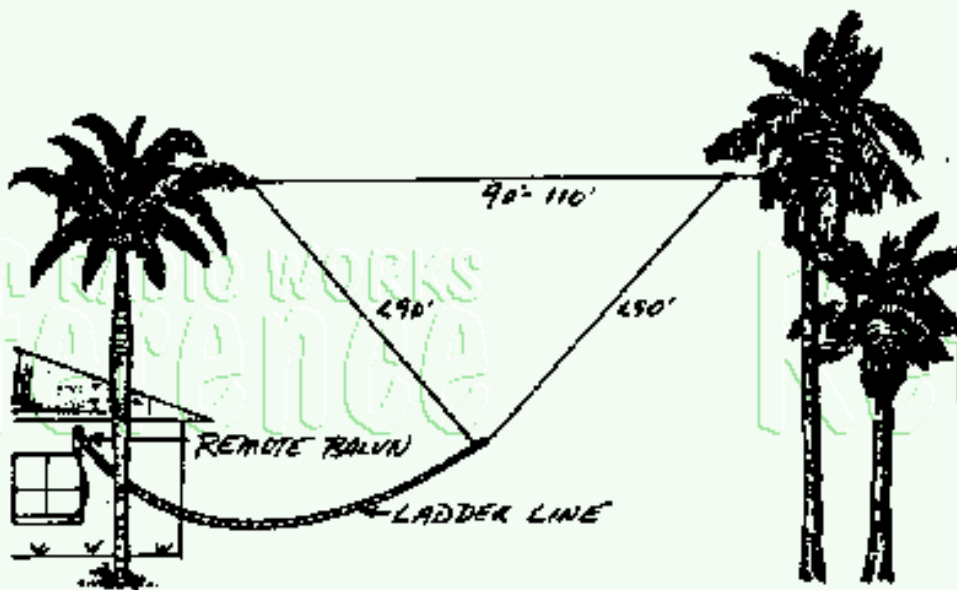
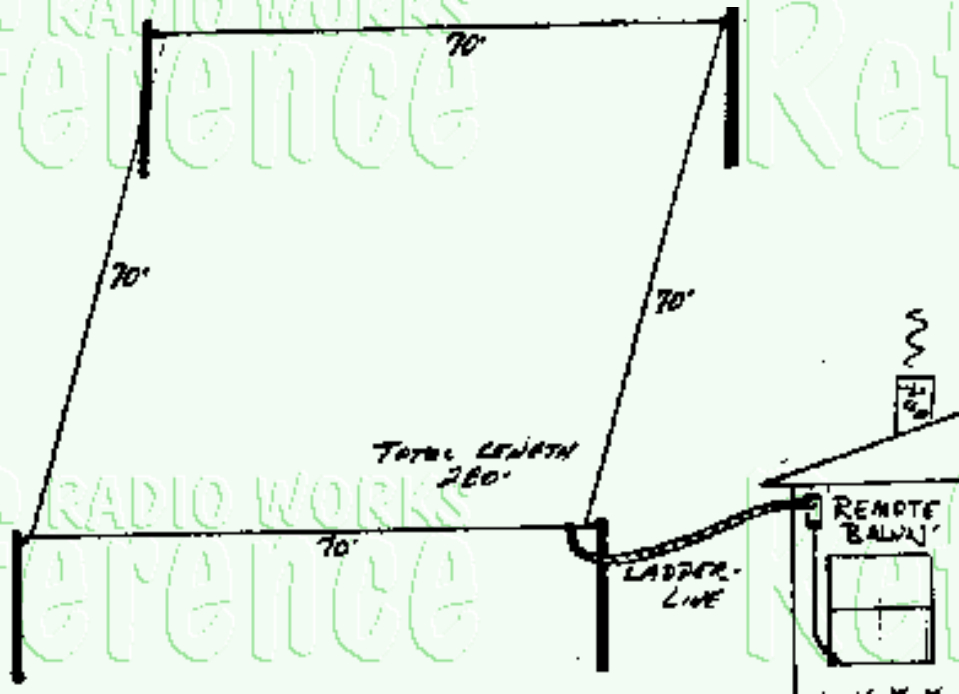

Full-wave loops are very popular antennas. They are especially useful on 80 and 40 meters where they perform well at modest heights. These are closed loops that are one full wavelength long. Horizontal loops may be fed at any convenient spot. For best performance, make your horizontal loop into a square, especially if it is to be used on several bands.

The Vertical Loop is a good DX antenna. The shape can be a circle, square, rectangle or a triangle. The larger the area of the loop the better it will work. Feed square and rectangular loops at a corner. For best results, triangular loops should be supported apex-down. This puts less of the antenna parallel with the ground and increased the effective height. Feed triangular loops either at a corner or in the case of apex-down loop, at the apex.

Use ladder line and a wideband transmatch (a naturally balanced tuner, like a Johnson Matchbox) for multiband operation. The RemoteBalun 4 is recommended if you will have problem getting ladder line to the operation position. Multiband operation is possible when feeding the loop with coax. The losses will be slightly higher, but the convenience of the coax may be worth the slight signal loss.

The design frequency, the feedpoint impedance, will be between 80 and 150 ohms. Coax fed loops will usually have an SWR between 2:1 and 3:1. You may feed this antenna with a 4:1 balun. If the loop is in the shape of square or large rectangle, the SWR can be below 2:1, but will not get much below 1.5:1.

If you decide to feed your loop with coax, I'd suggest using RG-8X or RG-213 and a high power, high performance 1:1 or 4:1 Current-type balun. Experiment with full-wave loops. You may find them to be excellent multiband antennas.

Antenna wire can be #14 hard-drawn antenna wire. Use #12 wire for large loops on 160 or 80 meters.

| Center Frequency | Total Length in feet | Center Frequency | Total Length in feet | Center Frequency | Total Length in feet |
|------------------|----------------------|------------------|----------------------|------------------|----------------------|
| 3.5 MHz | 287 | 10.12 MHz | 99 | 28.0 MHz | 35' 10" |
| 3.6 | 279 | 14.0 MHz | 72 | 28.5 | 35' 3" |
| 3.7 | 272 | 14.2 | 70 | 29.0 | 34' 8" |
| 3.8 | 264 | 18.12 MHz | 55' 6" | 29.5 | 34' 1" |
| 3.9 | 258 | 21.0 MHz | 48' 10" | --- | --- |
| 7.0 MHz | 143 | 21.2 | 47' 6" | --- | --- |
| 7.2 | 139 | 24.93 MHz | 40' 4" | --- | --- |

With this particular antenna, a RemoteBalun 4 and Ladder Line are used to permit multiband operation. If you have a naturally balanced tuner (i.e. a Johnson Matchbox), the RemoteBalun 4 is not needed. Click on the Balun Index do check out the the RemoteBalun's application notes.

Balun Index

↑
TOP

Jim's Notebook Index

Reference

Reference

Reference

Reference

Reference

Reference



- [Home](#)
- [Links](#)
- [Calendar](#)

Members Only

- Messages
- Chat
- Files
- Photos
- Database
- Polls
- Promote

([Already receiving group email?](#))

Description

Category: [Shortwave](#)

Discussion of loop antennas on all bands including ferrite loops, air core, all types. All bands SHF, VLF, LF, MF, HF, VHF, UHF, etc. Shortwave, longwave, receivers, transmitters, all fair game here.

Trying to resurrect the old LoopAntennas list without the melodrama. Please post links, files, etc. Please write a good description of files and links when you post them. I saved all the links, we'll have to build up the archives again.

All new members are moderated until you post once or twice, or if I recognize you. Spammers will be handled with minimum fuss.

What's New

Nothing new within the last 7 days

Message History

| | | | | | | | | | | | | |
|------|-----|-----|-----|-----|-----|-----|-----|-----|-----|-----|-----|-----|
| | Jan | Feb | Mar | Apr | May | Jun | Jul | Aug | Sep | Oct | Nov | Dec |
| 2004 | | | | | | 131 | 21 | 49 | | | | |

Group Email Addresses

- Post message: loopantennas@yahoogroups.com
- Subscribe: loopantennas-subscribe@yahoogroups.com
- Unsubscribe: loopantennas-unsubscribe@yahoogroups.com
- List owner: loopantennas-owner@yahoogroups.com

Yahoo! Sponsored Links

[Ham Radio Batteries on eBay](#): Find ham radio batteries at low prices. With over 5 million items for sale every day, you'll find all kinds of unique things on eBay - The World's Online Marketplace.
www.ebay.com

Group Info

Members: **219**
 Founded: **Jun 7, 2004**
 Language: **English**

Group Settings

- Listed in directory
- Open membership
- Posts from new members require approval
- All members may post
- Archives for members only
- Email attachments are permitted

Copyright © 2004 Yahoo! Inc. All rights reserved.

[Privacy Policy](#) - [Copyright Policy](#) - [Terms of Service](#) - [Guidelines](#) - [Help](#)

G4FON**Amateur Radio Station
G4FON**[Home](#)[Koch CW Trainer](#)[Portable Loop Antenna](#)[Loop Antenna Version 2](#)[QSO Diary](#)[QRP Wattmeter](#)[Musings on the
'Miracle Whip' design](#)[Contest Trainer](#) UPDATE[email](#)**NEW** **Coming Soon**[Auto ATU with Iambic Keyer](#)[SWR Meter and PSK Monitor](#)[Fishing Pole Antenna ideas](#)

You are visitor number

082 173

since 09/29/00

Last Modified: NaN/NaN/NaN

Copyright 2000- 2004

Ray Goff, G4FON

All Rights Reserved

g4fon

Welcome to my web site, my name is Ray Goff.

I was brought up in Farnborough, Hampshire and first became interested in radio at the tender age of eight while staying with my older cousin for a weekend and we built a crystal set together. This interest developed throughout my teenage years, to the extent that in my late teens I was running a lucrative business mending all the neighbourhood TV's and Radios.

At the same time I became interested in short wave listening after my father produced an old German Torn Eb TRF receiver, which he soon augmented with an R1155 set. This was the end of the 1960's and I had already joined the local Farnborough and District Amateur Radio Society.

In 1969 I started evening classes to pass my RAE exam. The course was held in a local school under the tutelage of John Hardy, G3KND. I passed the exam at the first attempt in May 1970, but was determined to hold out the for the 12 WPM Morse

test and a full license.

By 1973, while at university, it became clear that despite my best efforts, including help from another student, G3VMO, I was not going to pass the test in the foreseeable future, so I applied for a Class B, VHF only privileges license and received the callsign G8HMH.

Briefly back in Farnborough again, I joined another evening class led by Colin, G3XUU, to learn Morse code and in November 1976, finally passed the Morse test at a coastal radio station in Southampton and upgraded to my Class A license, G4FON.

From 1981 to 1984 I was G4FON/W9 while living in Chicago and then G4FON/W1 until 1989 while living in the Boston area.

In 1989 I returned to the UK and now live in the centre of Oxford which presents problems for HF operation. After a number of years of inactivity, I can now be found on 20, 30 and 40 metres CW, usually in the QRP section of the band.

This website reflects my main interests; QRP CW operating,

homebrew construction and the contesting. You are encouraged to look around and make use of anything you find. I would love to hear about anything you find useful, so drop me an [email](#)

On this website you will find a [CW trainer](#) which I wrote to build my CW speed back up, construction notes for [homebrew](#) equipment and aerials and a [logging programme](#) for the Palm OS. You will also find my latest programme, a Windows based [CW Contest trainer](#).

More recently, I visited the Farnborough and District Amateur Radio Society for a meeting and renewed some old friendships and I am an active member of both the [Oxford and District Amateur Radio Society](#) and the [Newbury and District Amateur Radio Society](#).

[Home](#)
[Purchase](#)
[Get Our CD-ROM](#)
[News](#)
[Documentation](#)
[Message Board](#)
[Support/FAQ](#)

[Radiation Detectors](#)

General Interest Programs

[Atomic Mac](#)
[Audiocoder](#)
[Audio Toolbox](#)
[Black Cat Timer](#)
[Diet Sleuth](#)
[iUnit](#)
[Health Tracker](#)
[MacPAG](#)
[Sound Byte](#)

Amateur Radio Programs

[Audiocoder](#)
[Black Cat CW Keyer](#)
[DX Toolbox](#)
[Elmer](#)
[iDXCluster](#)
[Morse Mania](#)
[MultiMode](#)
[Mac Prop](#)
[Mac Grayliner](#)
[RF Toolbox](#)

[About Black Cat Systems](#)

[Site Map](#)
[Our software for Mac OSX](#)
[Privacy Policy](#)
[Update Policy](#)
[Press/Media](#)
[Consulting](#)
[Macintosh Links](#)
[Shortwave Radio](#)
[Pirate Radio](#)
[Spy Numbers Stations](#)
[Science and Electronics](#)



Priced from just \$149

RF Toolbox

RF Toolbox is an antenna design and electronics/electrical tool package. It takes you step by step through the design of the following types of antennas:

- Dipole
- Fat Dipole
- Yagi
- J-Pole
- Super J-Pole
- Log Periodic
- Cubic Quad
- Vertical

It also performs the following calculations:

- Coil Design
- LC Filter Design
- Transmission Line Loss
- L Matching Networks
- Pi Matching Networks
- Impedance Calculations
- Wire Gauge and Resistance and Voltage Drop
- Wire Inductance Calculations

Super J Pole Antenna

Frequency: MHz

Phasing: 0.472 meters. 1 feet, 6.59 inches

0.944 meters. 3 feet, 1.19 inches

Spacing: 0.028 meters. 0 feet, 1.11 inches

1.417 meters. 4 feet, 7.79 inches

0.472 meters. 1 feet, 6.59 inches

Feed: 0.071 meters. 0 feet, 2.82 inches

Spacing: 0.032 meters. 0 feet, 1.26 inches

The diagram shows a Super J Pole Antenna with a vertical main stem and a horizontal phasing section. A secondary vertical stem is connected to the phasing section. Dimensions are provided in both meters and feet/inches for various parts: the main stem length (1.417m), the phasing section length (0.472m), the secondary stem length (0.472m), the feed point offset (0.071m), the spacing between the phasing section and the secondary stem (0.028m), and the spacing between the secondary stem and the main stem (0.032m). The total height of the antenna is 0.944m.

Wire Gauge and Voltage Drop

Gauge: 16 (Select from table below)

Length:

Resistance: 0.1405 ohms

Current: Amps Voltage Drop: 0.703 V

| AWG | Diameter (inch) | Area (circular mil) | Resistance per 1000 ft |
|-----|-----------------|---------------------|------------------------|
| 9 | 0.1144236 | 13092.75 | 0.7921178 |
| 10 | 0.1018971 | 10383.02 | 0.9988421 |
| 11 | 0.090742 | 8234.111 | 1.259517 |
| 12 | 0.0808081 | 6529.947 | 1.588221 |
| 13 | 0.0719617 | 5178.483 | 2.00271 |
| 14 | 0.0640837 | 4106.724 | 2.525371 |
| 15 | 0.0570682 | 3256.78 | 3.184434 |
| 16 | 0.0508207 | 2582.744 | 4.015497 |
| 17 | 0.0452571 | 2048.209 | 5.063448 |
| 18 | 0.0403027 | 1624.304 | 6.38489 |
| 19 | 0.0358905 | 1288.131 | 8.051197 |
| 20 | 0.0319615 | 1021.535 | 10.15237 |
| 21 | 0.0284625 | 810.1138 | 12.80101 |

Download

Buy it Now!

The cost of buying RF Toolbox is only \$14.99!

Buy your copy online, and get your registration code in minutes!

RF Toolbox is available for both Macintosh and Windows systems!

Email your comments and questions to info@blackcatsystems.com

Last modified October 18, 2003

Welcome to W2BRI's Magnetic Loop Site

Magnetic Loop Antennas for HF & Above

Last Updated October, 18th 2003

New Review of the AOR ARD9800 Digital Voice Modem!



New!

W2BRI gets the digital voice bug. Aside from my love of magnetic loops, I have been focusing my attention towards a new mode of communication for ham radio, digital voice.

[Here is a link to my Digital Voice site.](#)

My **new review** of the AOR ARD9800 Digital Voice Modem is ready for your [reading pleasure!](#)

Introduction

My current passion in radio has become the Magnetic Loop Antenna, also referred to as STLs, small transmitting loops. This site is dedicated to these antennas, and I strive to make this

Site Menu

[A. Magnetic Loop Antenna FAQ](#)

In this section you will find theoretical and practical information regarding mainstream beliefs, practical observations, and down to earth theory about these antennas. This FAQ will answer many major questions.

[B. My 80 Meter Magnetic Loop Antenna](#)

Find out about my largest magnetic loop for 40 and 80 meters. This page tells the story about how I came to learn about magnetic loops, and my experiences with this wonderful antenna.

the most comprehensive site possible. Magnetic Loops should not be confused with full size resonant loops commonly found in many radio operators backyards. The Magnetic Loop antenna has some special properties which distinguish it from many antenna designs like the dipole.

A major advantage of the magnetic loop is its high efficiency and small size. The magnetic loop is typically smaller in circumference than 1/4 wavelength of the desired operating frequency. There are many more advantages I plan on describing on this site and some disadvantages. The antenna is ideal for restricted operating areas and for portable operation. They can work close to the performance of a full size dipole antenna

(sometimes exceeding a dipole) and do not require radials. They can be mounted low to the ground, and will exhibit a high level of performance. However, they tend to be very expensive devices when bought commercially. They can be homemade with relative ease, and this site will teach you how to build your own if you so choose.

Loop antennas are elegant antenna systems, but they are far from simple. The Magnetic Loop is a complex antenna and will not simply work as a plug and play solution. If one desires using the loop antenna effectively, a decent understanding of the antenna's characteristics are crucial. A Magnetic Loop can work very well for an operator if they understand the different variables necessary to make it work well. My intention is to elucidate many of these issues on this site and make it easier for operators to use these antennas successfully. I also intend to discuss some of the myths related to loop construction, and hope to clear up some possible misconceptions others have encountered in with this interesting antenna.

My hope is to open up the technology to more operators. I will welcome phone calls and questions at 818-505-0222 or by email at brian@standpipe.com, but perhaps you'll find the

[C. How to Build Your Own Magnetic Loop Antenna](#)

If you wish to build a Magnetic Loop antenna and have questions about how to make it work, this section is for you. This five step project plan explains all the steps to creating your own magnetic loop from basic plumbing materials. The article features step by step instructions and how-to pictures to guide even the most basic beginner in Magnetic Loop construction. The article also features a section on capacitors and loop tuning. It is a must read.

[D. Images and Notes from other Loop Builders](#)

You are not alone. There are many others out there building and experimenting with Magnetic Loops. This section features great articles and pictures of other loop builders and their experiences. If you are serious about what's going on out there in the world of Magnetic loop, then this section is essential. If you are interested in submitting an article, please send me an email at brian@standpipe.com

[E. All About Variable Capacitors](#)

Many of you have asked for this section and here it is! Where to buy your vacuum variables, what to watch out for, and how to use them. This section also covers air variables, sources to buy them, and additional info. Enjoy.

answer to what your looking for on this site and build it yourself!

I am always looking for original artciles, images, and info on Magnetic Loops. Please email me at:

brian@standpipe.com

if you would like to submit content for the site.

If you are interested in the topic of project management, I write a monthly article which can be found at www.allaboutpojects.com

[F. Loop Software Page](#)

In this section you'll find some very easy to use loop modeling software. It's as easy as pie to plug in your desired parameters and see how well your antenna will perform theoretically. There is also a very cool homebrew capacitor design program. Check it out!

Coming Soon

More Projects, A Motor Controller Page, and More Articles from Other Loop Builders

Please email me at brian@standpipe.com

Copyright 2002 Brian Levy

Wellcome on DJ3TZ's Small Tuned Loop Antenna Page !



My first homemade STL ``Mag-1".

(Mni tnx to Markus DL5OBZ for the photo! Click for a larger version (719kB).)

I intend providing more detailed information here, but so far there are only some links.

Links to other ham radio small tuned loop (STL) pages:

- [Guenther DH7BZ](#) gives details about his homemade STL and practical experience (in german)
 - [Visit the homepage](#) of Carl GW0TQM with plenty of information on almost every topic related to STLs, including many references and links. (page still active?)
 - [A collection](#) of homebrew antenna links maintained by Rod AC6V, with many pointers to STL pages.
 - [An article archive also covering loop antennas](#), maintained by Willian Eric WD8RIF, including STLs.
 - [Peter VK3YE](#) gives a detailed description for a homemade STL
 - [Stephen AA5BT](#) describes STL construction
 - [Tony ON4CEQ](#) describes his homemade STLs. Don't miss the photos!
 - [John G3PTO](#) describes the G3BGR Magnetic Loop, lots of antenna links
 - [Jindra OK1FOU](#) gives a detailed description of his homemade STL
 - [Harry SM0VPO/G4VVJ](#) describes his [160m/80m loop](#) and a [remote antenna tuner](#)
 - Frank G3YCC describes [the STL published by Tom GM3MXN](#) and [the "Rock Loop"](#)
 - [Jess Dypin N0TFI](#) also presents information about the "Rock Loop" (page still active?)
 - [Don't miss the](#) "Loop Antenna Discussion" article archive
 - [Minowa 7N3WVM](#) describes a STL made from printed circuit boards
 - David PA3HBB/G0BZF describes [practical experience](#) with building and using loop antennas
 - Folkert PA3CQR gives information about his [STL covering 10 - 17m](#)
-

Capacitors:

- [Click here](#) for references to articles about homemade HV variable capacitors in amateur radio magazines
 - [Tony ON4CEQ](#) describes in detail how to make your own air variable butterfly capacitor
 - [RF Parts](#) offers high power air variable capacitors
 - [Jennings](#) is well-known for their vacuum variable capacitors
-

There are several programs to compute STLs:

- [FTP site](#) with lots of ham software, includes STL programs
- [Many ham-related](#) computer programs written by Reg G4FGQ, including STL computation

No time to build your own loop? Click here for links to STL manufacturers and reviews of their products:

- [Small Tuned Loops](#) by WiMo Elektronik
- [AMA](#) (german abbreviation for "tunable magnetic antenna") loop antennas made by Kaeferlein electronics
[Click here](#) for references to reviews in amateur radio magazines
- [The High-Q Loop Antennas](#) by MFJ
(Their pages also contain the manuals.)
[Read the experience](#) of Bob VO1DRB/WA6ERB/VE2DRB using this antenna for QRP operation
[Click here](#) for references to reviews in amateur radio magazines
- AEA seems to be off market, but you might find their IsoLoop Antenna on a flea market or so.
[Experience report ``Work the World with an AEA IsoLoop" by Don W6TNS](#)
[Click here](#) for references to reviews in amateur radio magazines
- [Broadcast band RX loop](#) by Kiwa Electronics

Did any link change? Are there any good pages missing? [Let me know!](#)

Any comments? Click here to [read and sign my guestbook](#)

Please do not bookmark this page but only my start page <http://www.qsl.net/dj3tz/index.html> as the structure of my pages might change.

Last modified: November 26, 1999

[Back](#) to DJ3TZ's homepage

Magnetic Loop Antenna = Mag-Loop, Small Transmitting Loop

Felix Meyer

(Update: March 8, 2003, Dec. 17.03, Jan 5,04, Jul. 4,04)



The magnetic loop antenna is an extremely efficient short wave antenna for the small size it constitutes. It consists of a loop radiator made of copper or aluminium tubing and a tunable capacitor.

The size of the antenna is very small as compared to the size of a traditional antenna as dipole, beam, quad or vertical. The diameter of the loop is in the range of 1/10 to 1/100 of the wavelength.

The antenna works with the magnetic component of the EM field, which extends to the both EM components on larger distance. For that reason the antenna operates well close to ground and radiates a much stronger

signal than a dipole when both are close to ground. Surely, a full size dipole mounted in its optimal height radiates better than a magnetic loop, but due its efficiency at low height the magnetic loop is an excellent portable antenna or may be used well as indoor antenne when external antennas are not permitted.

The capacitor of the antenna needs to be remotely adjustable to allow a frequency tuning range from 1:2 or 1:3. When properly built, the SWR is below 1.1 on the tuned frequency over the full tuning range.

The bandwidth is always very small and covers only a few KHz. The high Q of the antenna allows a selective reception and suppresses effectively QRM of nearby BC stations, as well as other QRM.

Here I am using 2 loop antennas, one for 3.5 to 10 MHz and one for

14 to 30 Mhz, both antennas with only 85cm diameter, below the roof.

The 14 to 30 MHz antenna with 50 W output allows for regular worldwide contacts with good results.

The antenna can be built easily as homebrew project if one can find or build a suitable capacitor.

Below you will find a loop calculation program for your own design together with detailed instructions for magnetic loop antennas from 3.5 to 30 MHz.

[Calculation program LOOPABXE.EXE](#) click for free download (new version Dec.31, 2003) with calculation of multiturn loop, calculating all electric data.

>>> [Explanation of program changes here.](#)

For those who are interested: [Formulas used by HB9ABX to design mag. loop](#)

[Circuit for motor control](#) Diagram 6th. Aug 1999

[Construction of Mag-Loop](#) (portable / indoor 14 - 30 MHZ)

[Picture of loop 14 - 30 MHZ](#) (Photograph thanks HB9DRJ)

[Construction of Mag Loop 3.5 - 10 MHZ](#)

[Picture of Loop 3.5 - 10 MHZ](#) (Photopgraph thanks HB9DRJ)

[Control through Coax](#)

Magnetic Loop Antenna : Construction hints

The following instructions should be observed
for successful construction and operation of magnetic loop antennas:

DANGER : IMPORTANT NOTES !

The radiated field is very concentrated and may produce health problems.

Therefore, one has to keep distance to antenna of at least 5 meters

if the power exceeds 10 watts.

Coupling to the loop is done mostly at the lower side of the loop and the tuning capacitor is placed on top. Due to mechanical stability I installed the capacitor with motor on the bottom and the coupling loop on the top without having any deficiency in HF radiation.

There are several coupling loop constructions. The simplest one is by forming a loop of installation wire (bare or isolated), or using a coax cable (type RG58). The diameter of the coupling loop is about 20% of the diameter of the transmitting loop. One end of the coupling loop is soldered to the center conductor of the coax, and the other end of the coupling loop is soldered to the braid of the coax. There are several types of feeding: either capacitive coupling or inductive coupling. The easiest one being just a [simple wire loop as you see here](#).

Here you see a [capacitive coupling](#) and here you see a [gamma coupling](#). The position of the coupling loop is inside the loop, exactly opposite to the capacitor. At this point, the voltage of the transmit loop is zero. The distance between coupling loop and transmit loop varies from 0 to 6 cm. By changing this distance, the lowest SWR is adjusted. Fine adjustment can be done by changing the form of the coupling loop, wider or smaller.

A good coupling loop is the symmetrical loop which you see on this [picture](#).

The environment close to the loop influences this adjustment. With proper adjustment a SWR lower than 1.1 can be reached.

Main loop and coupling loop should not be connected directly, as RF coupling to the feeding coax may appear easily and can produce RF interference (TVI/BCI), therefore no direct connection between center of main loop and coupling loop.

However, the main loop may be charged by static electricity and discharges by producing QRM bursts. This can be eliminated by inserting a small coil between the center of the main loop and the coax braid of the feeding coax. If this connection is done without a coil, radio interference (RFI) may be

produced due to small misbalance.

Coil data: 40 turns of .2 to 0.5 mm enameld copper wire at 1cm diameter wound over 2 cm length.

The main loop may be made of tubing (copper or aluminum) or thick coax cable. If coax cable is used (RG213 or RG8 or similar) the inner conductor and the braid (= shielding/ground) is soldered together at both ends. These ends are then connected to the capacitor. Very high current flows in the main loop. Therefore, thick and short copper wires are required to connect the capacitor.

In tubes, the current flows only on the surface due to the skin effect, therefore the use of foil is an interesting method. Very efficient and lightweight loops can be built by using a thick plastic support and placing copper foils over this structure. The foil can be placed in narrow strips in the direction of the loop circumference, as placing the foil in one step produces crumpling.

The form of the main loop may be square, n-square or round. The round form is most efficient as the losses are minimal. (Best ratio of L:R).

Nearby environment affects the SWR. In free field, the body of the loop should be 2 loop diameters above ground. Good are 5 loops diameter hight, higher elevation gives only small signal difference.

If the loop is installed below the roof, then keep 10 to 30 cm space below roof brick and avoid nearby lines and metallic constructions. Note that the roof above the loop should not be a closed metallic construction.

It's important to observe that the feeding coax below the loop is kept

in the symmetric center between the two half loops straight downward at the length of one loop diameter.

By not observing this rule, RFI may be generated !

In any case, I recommend to insert a [broadband current choke](#) into the feeding coax, about 1 m away from the transmitting loop, as surface currents

on the coax cannot be prevented completely.

The loop capacitor needs to withstand high voltages and high currents. Butterfly capacitors are a very good choice as they have no sliding contacts. Variable vacuum capacitors are an excellent choice.

100 watts RF power produce about 4000 volts on the capacitor (see program). Required distance between plates is ~ 1 mm per 1000 V. Suitable capacitors are made by HB9TJX (address at end of page).

A DC motor with strong reduction (about 2000:1) serves to control the capacitor. Suitable motors can be found in airplane or car model shops.

(E.G: Robbe No.4103 with 2430:1 reduction).

Grill motors may serve also fine.

Please note that there is a high voltage isolation required between motor and capacitor.

I recommend to use pulsed DC current to control precisely DC motors. By adjusting pulse ratio properly, small increments may be controlled perfectly.

A suitable circuit diagram is included for that purpose.

(Switch: FAST/SLOW; keys: RUN und BACKWARD).

The remote control motor may be fed through the same coax feeding the loop, hereby no separate control cable is required. See link under: Control through coax.

Butterfly capacitors of different values for 6 KV are available at:

Markus Reber, HB9TJX

Eystrasse 7, CH-3400 Burgdorf, Switzerland, Tel: ++41 (0)34 423 16 79

See datasheet at <http://www.gsl.net/hb9tjx>

Vendors of Ferrite Toroids:

- <http://www.oselectronics.com>
- <http://www.palomar-engineers.com>
- <http://www.cwsbytemark.com>

Please send comments or questions by e-mail to: [see here \(click\)](#)
or by Packet Radio to: hb9abx@hb9eas.ch.eu

Manufacturers of magnetic Loops:

- [MFJ Loops](#) (good experience, cheap) (Product Catalog, Antennas, MFJ-1786, MFJ-1788)
 - Christian Käferlein, Darmstadt, Germany, Tel:(+49) 6151 61272, Fax (+49) 6151 663009
[Kaeferlein DK9CZ](#) (good, but not very cheap ...)
 - [HB9CRU](#)(I3VHF Magnetic Loop Antenna)
-

[Back \(HOME\)](#)

A Magnetic Loop Antenna

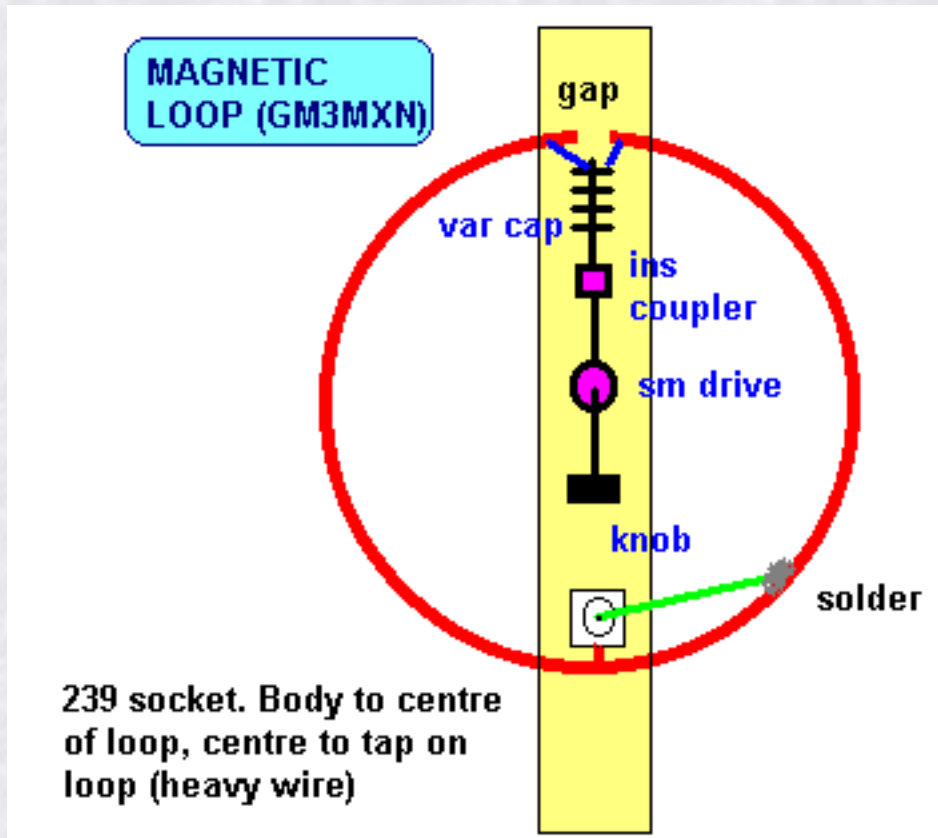

Various articles have appeared describing magnetic loops for HF use, some with complicated methods of remote tuning and the antenna can be quite a useful and interesting project.

The article in Sprat 61 by Tom, GM3MXN describes a loop useable from 7 - 21 MHz, using half inch copper tube 3 feet in circumference. As shown, there is a gap at the top of the loop, which may be about 3/4 inch, either side of which is connected to the tuning capacitor, which can be about 250 pF. The inner of the SO239 socket at the base of the loop is soldered onto the centre of the loop, with the inner forming a gamma match to the tube, about 9 inches from the earthy connection. This is adjusted for minimum SWR. As shown, the loop can be mounted on a wooden support and is fed with 50 ohm coax.

Notes

Tuning of the capacitor is very critical, and it may be advantageous to use more than one slow motion drive, which is what I did in my version.

It should be noted that a high potential is present across the gap, and even at QRP levels can be dangerous. Certainly with higher powers, this situation can be **LETHAL**. I would personally not recommend the use of such a loop in the shack because in my opinion even, QRP levels can produce what may be dangerous amounts of RF, which has been blamed for brain damage. Suffice it to say that I

know of one local who did use a mag loop indoors and wondered why the paint next to the loop was bubbling (!), and another who used a handheld VHF/UHF handheld, always with the rig next to his head. He died of a brain tumour. Whether there is any medical evidence or not, I think it wise to avoid situations of RF close to the body. *Is it worth the risk?*

For high power use a wide spaced capacitor is needed to avoid flash over.

Maximum radiation is off the ends of the loop, not broadside on, as in a quad or delta loop.

It will be necessary to retune the variable capacitor when QSYing, even slightly, as this is a high Q system. I used one on 40 meters and it proved fairly directional and quiet.

Other versions have used coax inner instead of copper tube. It is important to ensure that the loop is made from low ohmic material. If a square version is attempted, using say plumbers' connectors, ensure each joint is very well made, electrically.

[Click here to return to first page](#)

Magnetic Loop Antenna's.

Why is an Magnetic Loop antenna so special, this antenna is picking only the MAGNETIC part of the ELEKTRO MAGNETIC radio wave. The big advantage of this antenna is that the electric interference from the big city (streetlights, television's , cars etc...) have no influence on the received signal. With the loop you can hear other stations that you can't hear if you use a DIPOLE, with a dipole the stations are buried in the noise.

Multi Turn Magnetic Loop.

This is the first loop I build from a article in the QST from February 1996, it's 30 Inch-diameter, and it's designed by G2BZQ/WØ for 80 M.

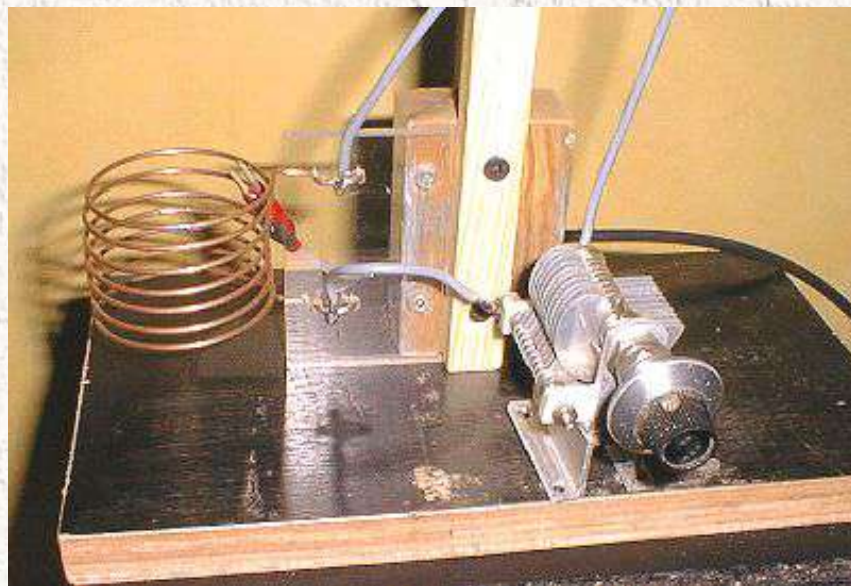
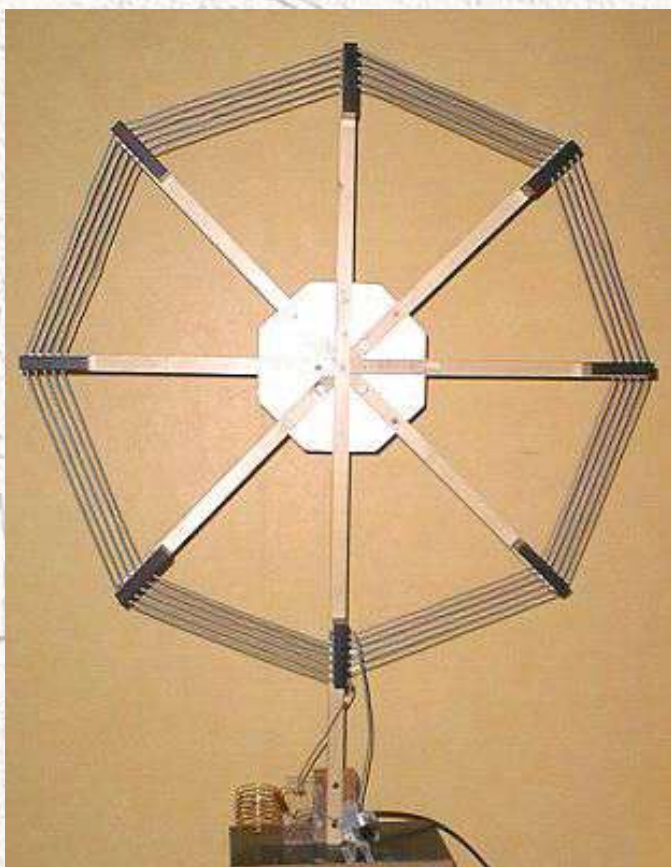

Single Turn Magnetic loops

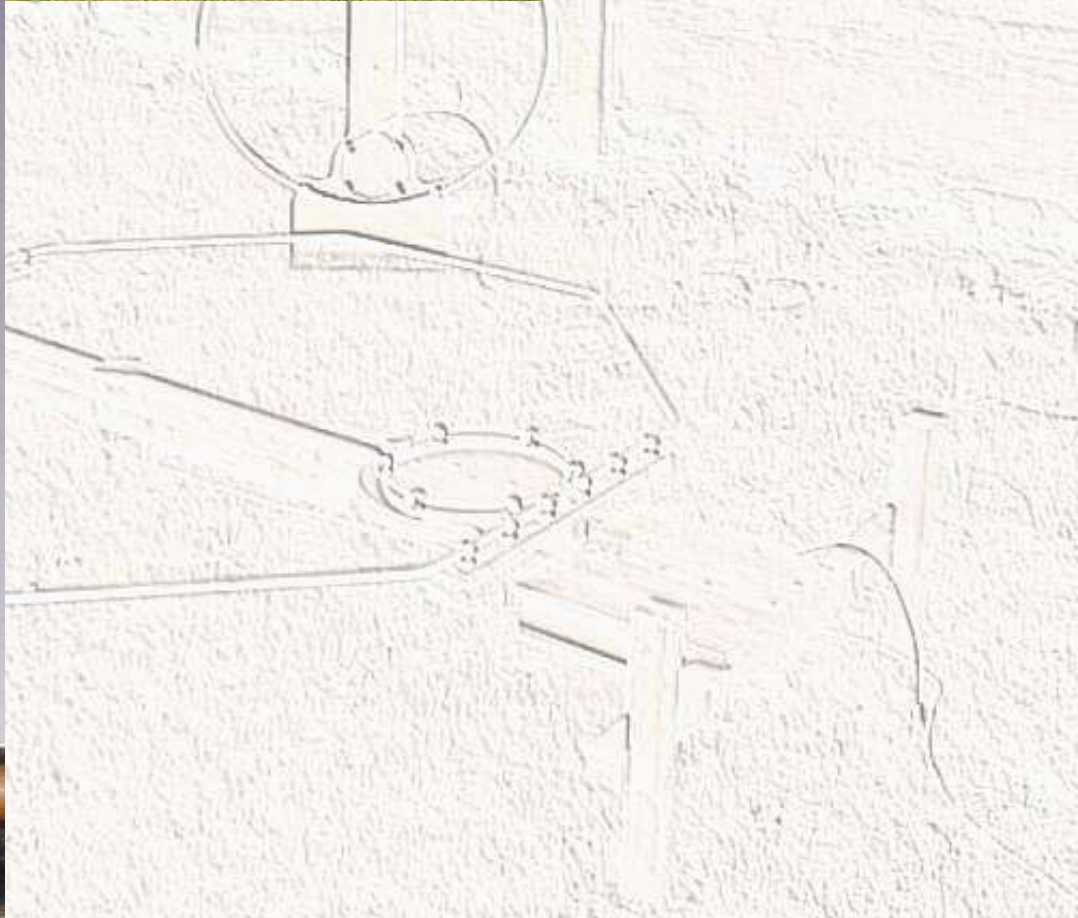

The first one turn loop that I built was made from 75 Ohm TV Coax and with a small explanation in the RSGB handbook for radio amateurs. I used the outer screen from the

coax and the results of the loop where good. The next loop I built is a octagon loop in 15mm copper tube with a circumference of 4.8 meter (16 feet).

The frequency range of this loop goes from 14 MHz to 7 MHz and works fine. The biggest problem is the tuning capacitor, if you transmit with a power of 100 W you need a capacitor with a voltage rating of 5000 Volt.

A capacitor which can handle this voltage is hard to find over here and if you find one they are very expensive.

The first capacitor I built was a design from GW3JPT from a article in the RADIO COMMUNICATION from February 1994. It is a split stator capacitor with a capacitance of 140 pF and with a voltage rating of 6000 Volt.

The capacitor is remote tuned with the use of a small BBQ spit motor.

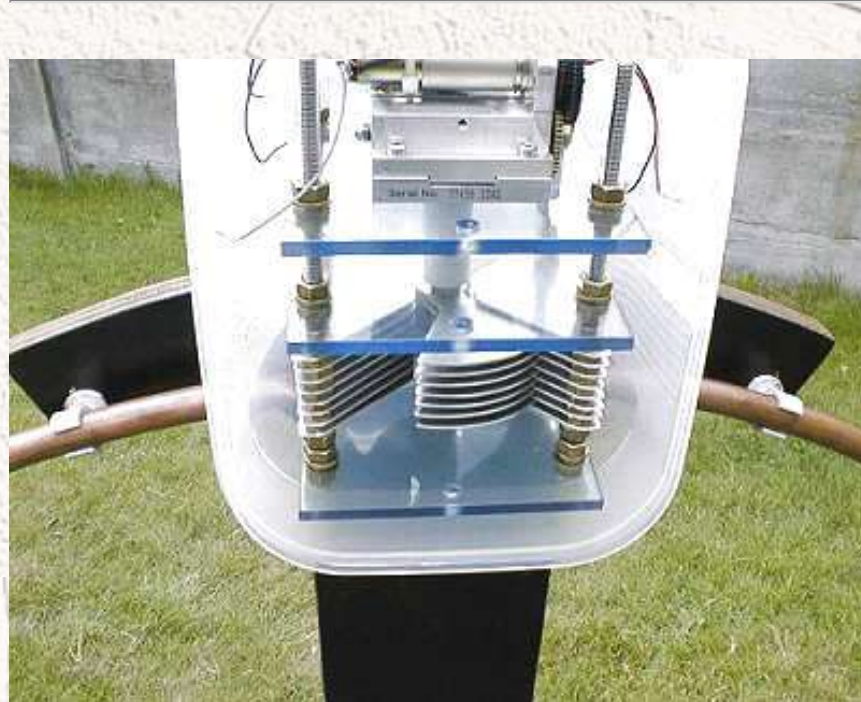

The second capacitor I built is my own design and it's a butterfly capacitor because the losses are lower than a split stator.

The capacitance is 5-65 pF and the voltage rating is 7200 volts. I used it for the small loop with a dia. of 800 mm (2.66 feet) and the frequency range of this loop is from 28 MHz to 14 MHz. The Aluminum plates of 1 mm for the capacitors are cut with a JIG SAW.

Most asked Questions:

I`d like to talk a little more on your setup. it seems like something which I could get together if only some more data was available. do you have any notes etc still laying about since its build ?

The theory for calculating the loop is very simple. The circumference of a magnetic loop is 1/4 wave of the design frequency.

Example for 14 MHz.

$$300 / 14 \text{ MHz} = 21.428 \text{ m is 1 wave}$$

$$21.428 / 4 = 5.357 \text{ m is 1/4 wave circumference}$$

$$5.357 / 3.14 = 1.706 \text{ m diameter.}$$

The recommendations are that you can tune the loop from the design frequency to the frequency divided by 2 to keep the efficiency acceptable.

$$14 \text{ MHz} / 2 = 7 \text{ MHz}$$

I made the small loop (800mm / 31.5 ") from soft copper tube on a role that you can buy in a plumbershop and it's easy to make a nice circle if you draw on the ground a circle with a rope and a piece of chalk.

For mounting the loop to the hardboard I used plastic clamps that they use for mounting copper tube on the wall.

why is a butterfly capacitor better?

For high voltages and currents the use of Capacitors with wiper contacts is not recommended. That's why they use capacitors in serie's. The pro for serie's capacitors is that the voltage rating is doubled. The anti is that the value of capacitance is divided by 2.

For the split stator capacitor the 2 capacitors are connected in series by the shaft (bleu) and the red spots on the first drawing are losses.

For the butterfly capacitor the 2 capacitors are directly connected in series by the rotors and gives less losses.

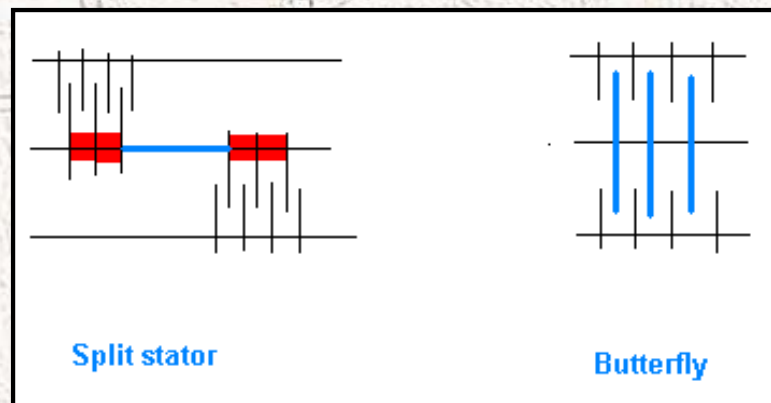

Do you know of anyone that has built a similar loop that outperformed a garden variety dipole?

Compare antenna's is very difficult , sometimes I have for 60 % better signals in RX and TX on the loops then on the dipole.

In Theorie is the performance of a magnetic loop - 0.4 dB lower then a dipole or a vertical .

I have over here a homebrew trap dipole from 40-20-15-10m and the height aboveground is only 7 m(23 ft), for a good performance on 40 m the dipole must have a height of 1/2 wave above ground (66ft). I don't have a radiation angle on 40 m and it's only good for contacts in Europe and not good for DX, now the 1.5 m loop tuned to 7 MHz with a efficiency of 38 % (38 w ERP) and a angle radiation of about 20 degrees performs better than the dipole because the vertical magnetic loop only 1 M above ground as a angle radiation and the dipole don't.

Another advantage is that the reception on a loop is mutch better, on 20m I have with the dipole S5 noise from the big city, if I switch to the loop I have S1 noise and hear stations who are buried in the noise when I use a dipole.

Coupling loop dimensions?

I find that the best way to feed the loop is with the shielded 1/5 Faraday loop made from coax RG213 or RG8, I tried the gamma match bud I had problems to keep the VSWR low on all Bands, the shielded loop gives on all bands VSWR 1.1 and reduce more noise pick-up then the gamma match.

I found out that if you use a 1/5 Faraday loop, that the loop is to big, making the loop smaller with 0.5 inch by the time in circumference and checking with a field strength meter you can see that the radiated power increase.

The place off the feeding loop is placed at the electrically neutral point on the loop and that is 180° from the capacitor and I have the best results with the feeding loop close to the ground and the capacitor far from the ground.

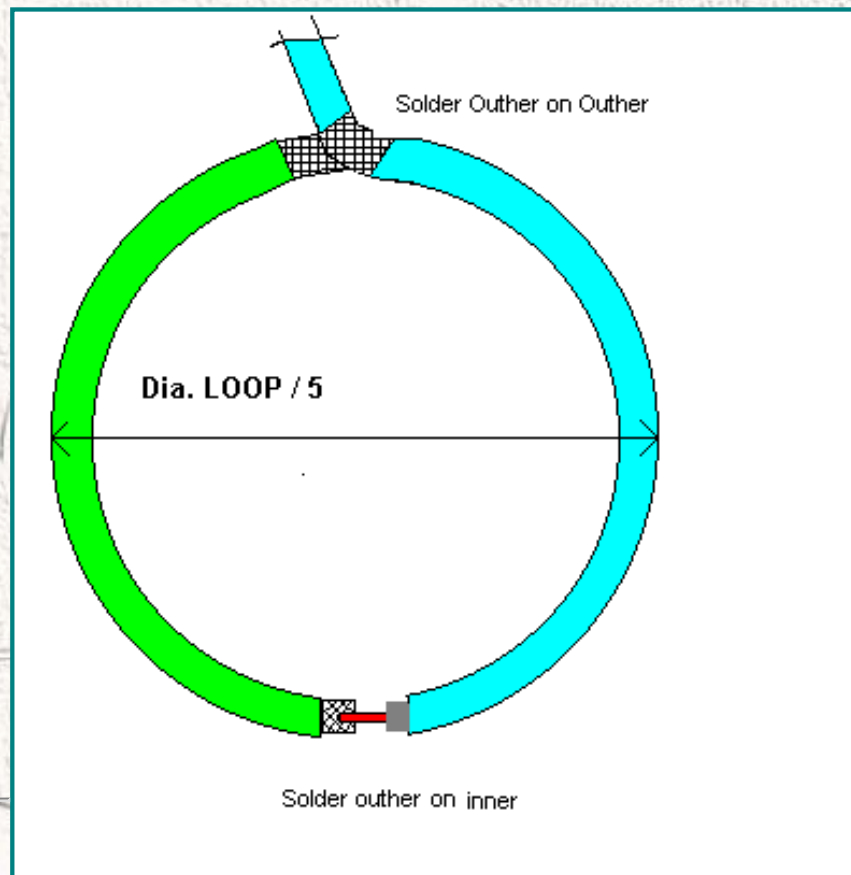

I was wondering if you worried about the resistance of the mechanical joints (copper pipe bolted to the capacitor) significantly reducing your radiation efficiency as I think the radiation of these antennas can get as low as .01 ohms

Soulder or weld the capacitor plates is always the best, but I'm afraid if you make the spacers and the plates in ALU that with welding everything is gona bend from the heat

and I know from practice (I work in a maintenance workshop) that welding ALU is coarse. Another possibility is using all brass or copper and solder, there are hams that using double PC board for the plates.

I made a QSO in phone with Florida, RPRT 5-5 and the other station used a vertical antenna, with the small loop (800mm and theoretical effieency 41 % on 14 Mc) vertical in the garden and the states side is through the house. I was very happy with the results , so I think that a capacitor maded with torqued compressed joints is good enough for using 100 W.

Have the dissimilar metal joints weather well?

To keep the oxidation low on the dissimilar metals I used a thin coat of vaseline after assemble the capacitor and with the tupper ware a like plastic box it is good protect against all wheather conditions.

How to find the radiation angle of the antenna?

Can it be found practically?

Finding the radiaton of a magnetic loop is very easy, with a TL-lichtgt tube you can see it, with abt 10 w power on the the loop with the TL-tube in the plain of the loop at right angle to the circle you see the tube lightning, there where the the light is the farest on the tube thats the radiation angle.

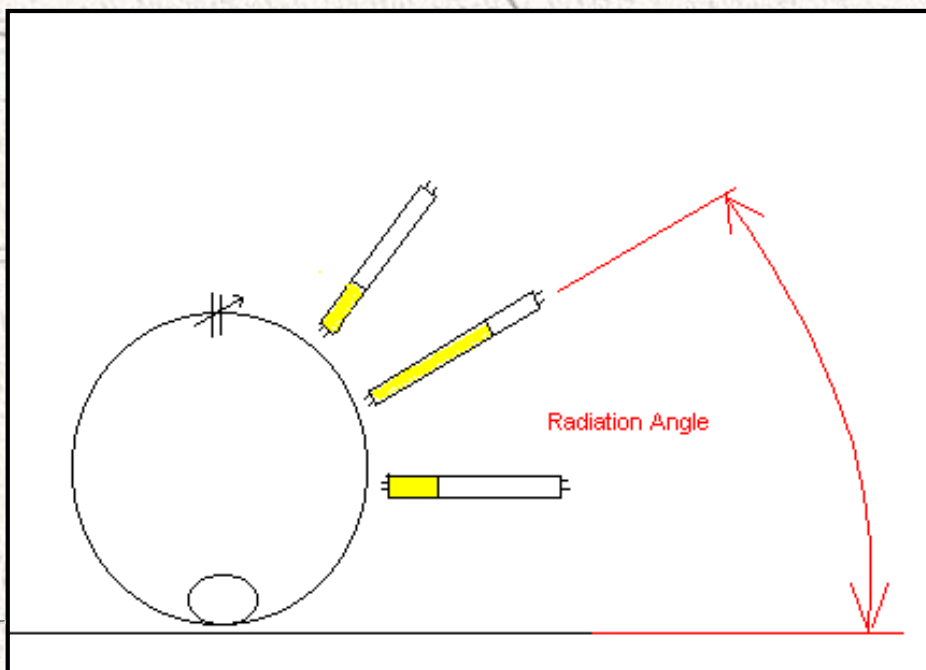

When you refer to washers, nuts and rods you use the term "M6".Please forgive my ignorance, but to what does "M6" refer? Does this mean 6mm?

M6 is (M=metrical) and 6 is indeed 6 mm threaded rod and you can compare the size with W1/4" (6.35mm) .

A very easy to build Piston Capacitor.

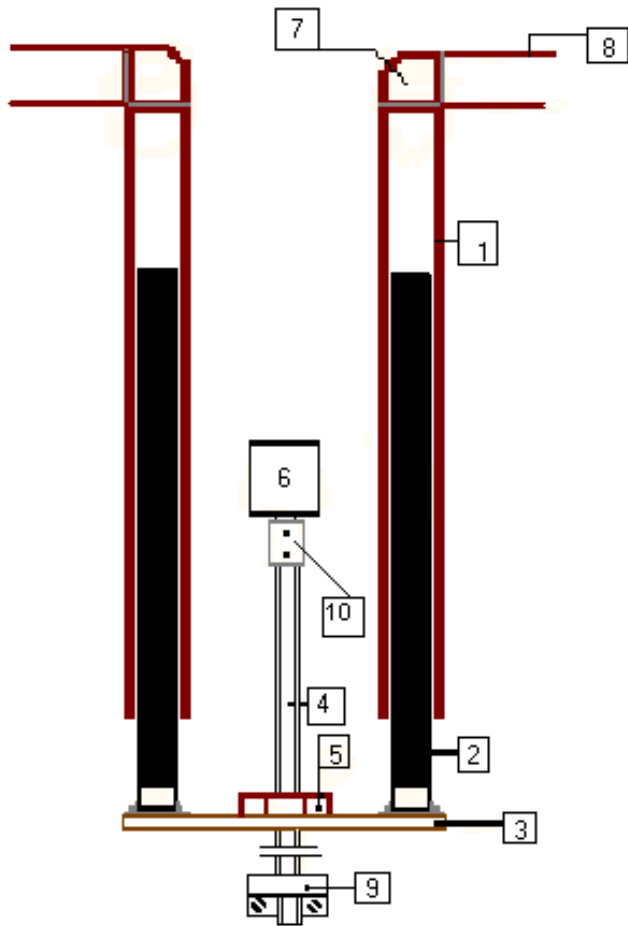

- 1) Copper tube
- 2) Coax RG8 or 213
- 3) Double PCB
- 4) Threaded Rod 1/4"
- 5) Brass nut
- 6) Motor with reduction or stepper motor
- 7) Copper Elbow 90°
- 8) Loop
- 9) Bushing from old var resitor
- 10) Couple shaft (PVC)

How to build your own Butterfly Capacitor.

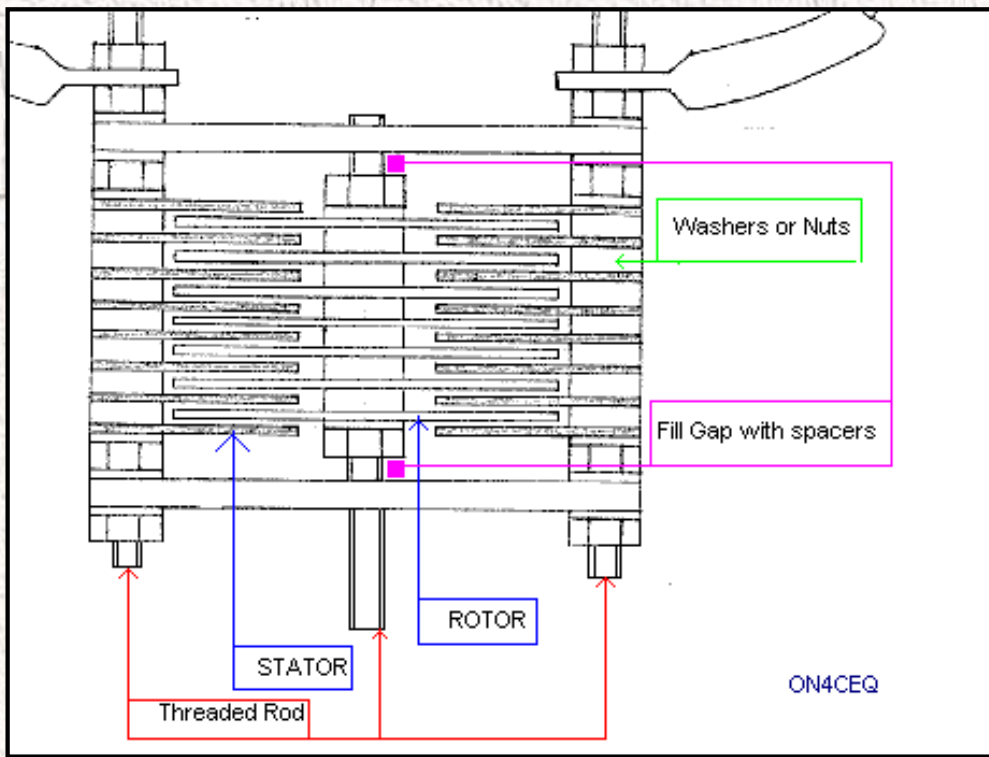

The best material for the front and the back is CLEAR PVC 3 or 5 mm thick as alternative you can use GREY PVC or 2 sheets pboard together with the copper removed .

The best material for the washers, nuts (M6) and threaded rod (M6) is brass or stainless steel,(NON MAGNETIC MATERIALS for the losses).

For the spacing of the vanes you can use 2 washers M6= (6Kv) or a nut M6 =(12 Kv) if you use aluminum plate 1 mm thick.

If you use a nut then the best thing to do is remove the thread by drilling withØ 6.2 mm.

The effective area for the vanes is 11.7 cm² and with the formula

for 2 washers = $(0.0885 \times 11.7 \text{ cm}^2) / 0.1 \text{ cm} = 10.35 \text{ pF}$ for 1 air gap.

for 1 nut = $(0.0885 \times 11.7 \text{ cm}^2) / 0.2 \text{ cm} = 5.17 \text{ pF}$ for 1 air gap

Example:

If you you make a capacitor with 2 washers as spacing and you make 5 rotor vanes and 6 stator vanes then you have 10 air gaps.

$10.35 \text{ pF} \times 10 = 103 \text{ pF} + 10 \text{ pF}$ stray capacitance = $113 \text{ pF} / 2 = 56 \text{ pF}$

The final result is a capacitor with a value from 5 - 56 pF.

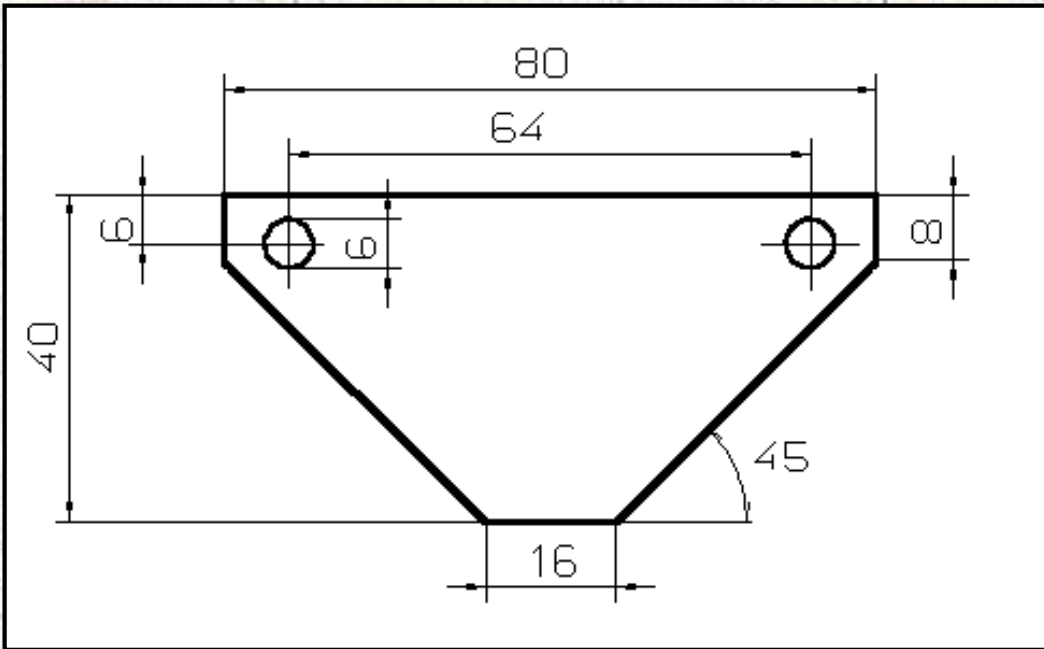
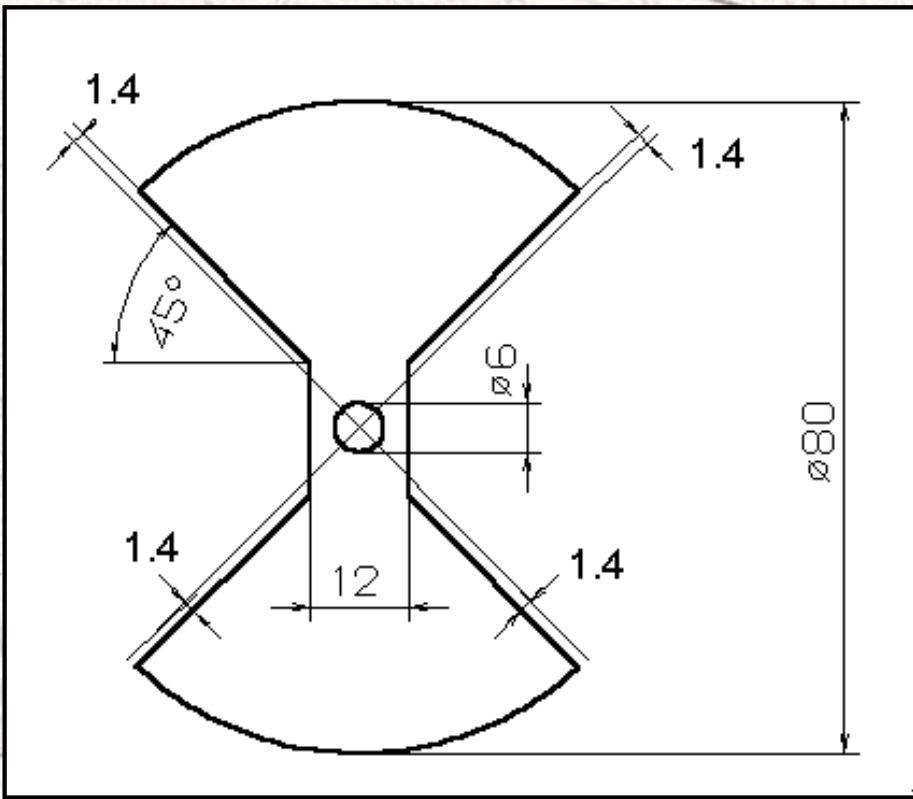

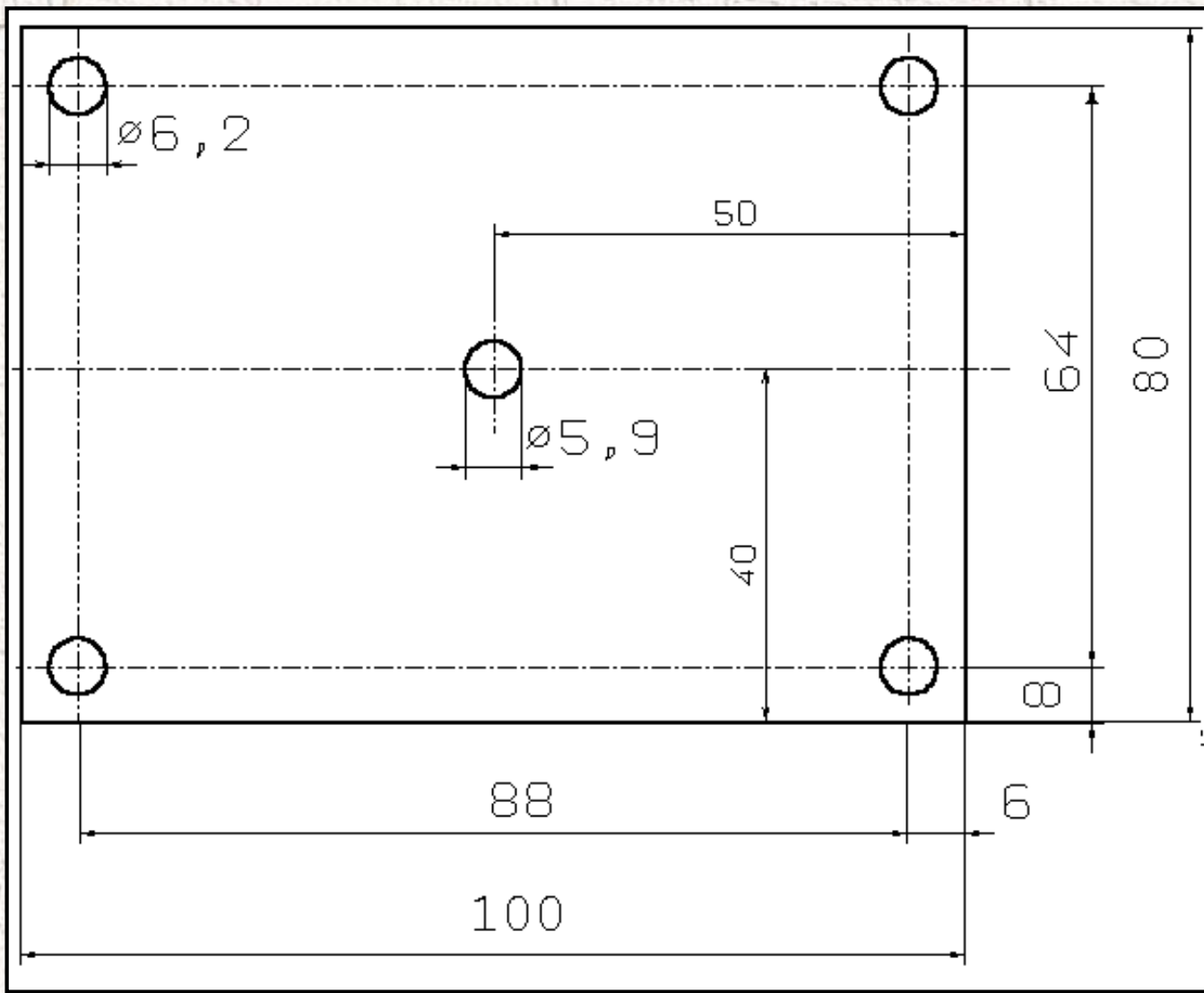

Last Update 03 December 1999. ON4CEQ Van Herck, Tony QTH: Anwerp(JO21FF) BELGIUM.

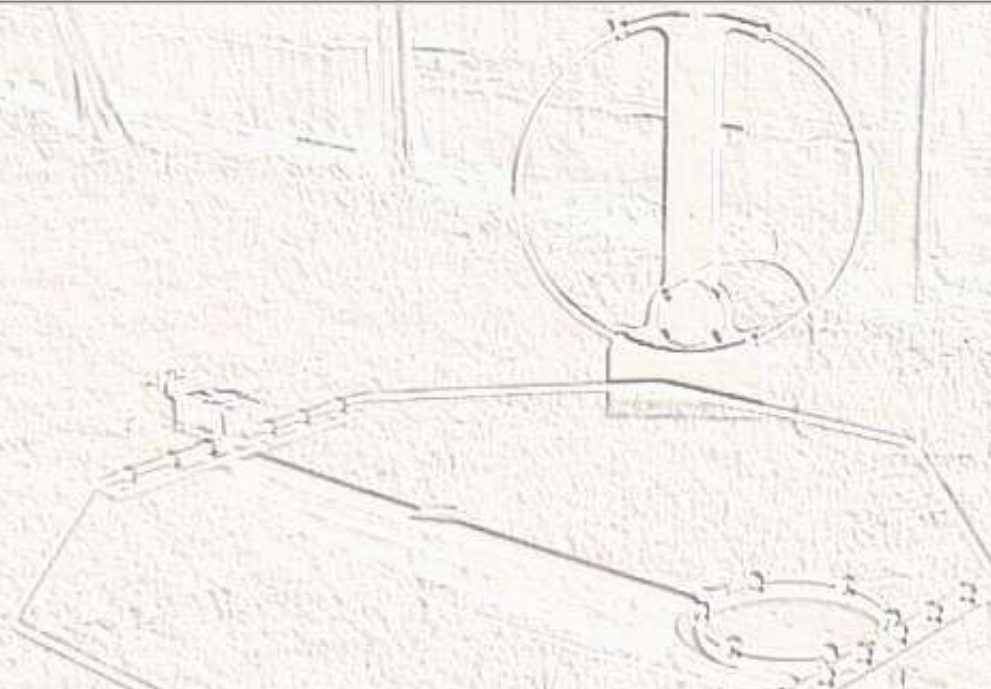

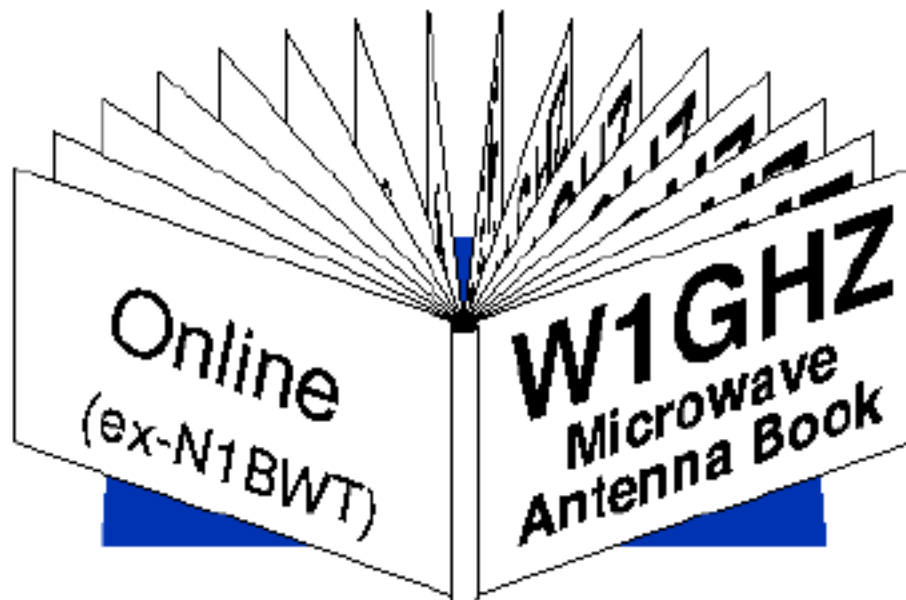

The W1GHZ Online Microwave Antenna Book

Paul Wade W1GHZ (ex N1BWT) ©

1994,1995,1996,1997,1998,1999,2000,2001,2002,2003

Table of Contents

[Preface](#) -30 September 1999

Part 1 — Practical Antennas

1. [Antenna Basics](#) - 25 September 1998
2. [Electromagnetic Horn Antennas](#) - March 1998
3. [Metal-plate Lens Antennas](#) - April 1998
4. [Parabolic Dish Antennas](#) - March 1998
5. [Offset-fed Parabolic Dishes](#) - 29 April 1998
Appendix 5A - [Common Offset Dishes](#) - October 1999
6. Feeds for Parabolic Dish Antennas - *in progress*
 - 6.0 [Introduction and Feed Index](#)- 23 September 1999
 - 6.1 Feed Phase and Phase Center - January 1999
 - 6.1.1-4 [Phase and Phase Center](#)

- 6.1.5 [Dish Patterns with Focus Error](#)
- 6.2 [Dipole and Wire Feeds](#) - *January 1999*
 - 6.2.1 Dipole feeds
 - 6.2.2 EIA dual-dipole feeds
 - 6.2.3 Loop feeds
- 6.3 [Circular Waveguide Feeds](#) - *January 1999*
 - 6.3.1 Coffee-can feeds
 - 6.3.2 WA9HUV -- Coffee-can with flange
 - 6.3.3 VE4MA feed
 - 6.3.4 Chaparral-style feeds
- 6.4 [Horn Feeds](#) - *30 September 1999*
 - 6.4.1 Conical horn feeds
 - 6.4.2 Rectangular horn feeds
 - 6.4.3 Corrugated conical horn feeds
- 6.5 Dual-Mode Feeds
 - [Part 1](#) - *30 September 1999*
 - 6.5.1 W2IMU dual-mode feed
 - 6.5.2 W2IMU dual-mode feed examples
 - [Part 2](#) - *30 September 1999*
 - 6.5.3 Diagonal horn
 - 6.5.4 Potter dual-mode conical horn
 - 6.5.5 VK2ALU dual-mode feedhorn
 - 6.5.6 Higher-order multi-mode feeds
- 6.6 Helical Feeds - *Coming soon*
- 6.7 [Other Feeds](#) - *14 October 1999*
 - 6.7.1 Clavin feed (1974)
 - 6.7.2 Backward or rear feeds
 - 6.7.3 *Diffraction*
 - 6.7.4 Backward or rear feeds continued
- 6.8 Radiotelescope Feeds
- 6.9 Multiband Feeds - *15 May 2000*
 - [Part 1](#) Multi-band dipole and horn feeds
 - [Part 2](#) Multi-band feed experiments, Broadband feeds, feed

assemblies

6.10 Multiple-reflector Dishes

Appendix 6A - [Parabolic Dish Gain & Beamwidth](#) - *October 1999*

Appendix 6B - [Setting up a Parabolic Dish Antenna](#) - *28 June 2000*

Appendix 6C - [Electromagnetic Fields in Feed Antennas](#) - *19 September 2001* ***NEW***

Appendix 6D - [Electromagnetic Field Animations](#) - *19 September 2001* ***NEW***

7. Slot Antennas - *8 July 2001*

[Part 1](#) Waveguide Slot Antennas

[Part 2](#) Performance Enhancements

[Part 3](#) Other Considerations, Two-dimensional slot arrays

[Part 4](#) Slotted-cylinder and Alford slot antennas

[Part 5](#) Summary and References

[Slot Antenna Update](#) - *30 May 2002* ***NEW***

8. [Periscope Antenna Systems](#) - *17 May 2000*

Part 2 — Antenna Measurement

9. [Antenna Range Measurements](#) - *April 1998*

10. [Antenna Measurements using Sun Noise](#) - *April 1998*

Part 3 — Computer Analysis of Antennas

11. [Parabolic Dish Feeds - Performance Analysis](#) - *March 1998*

12. [Pattern Calculation and Phase Analysis](#) - *October 1999*

13.

[Software Page](#)

Downloads:

[HDL_ANT.exe](#) *version 3b4* and [Source code 3b4](#) *March*

2003 - Minor corrections

[FEEDPATT.exe](#)

[PHASEPAT.exe](#)

[Periscopegain.xls](#)

[Slotantenna.xls](#) *30 May 2002 ***Updated****

[Copyright notice](#)



Home Brew dual band antenna

Generally speaking, this is a dual band design focused with better performance on UHF. It can satisfy needs on most situation. If you always work in hot areas where out-band cross modulation are causing trouble to your reception, this antenna might even improve the selectivity slightly. If you always work at marginal signal area and have to squeeze the last drop of energy from your system, this is not a suitable candidate.

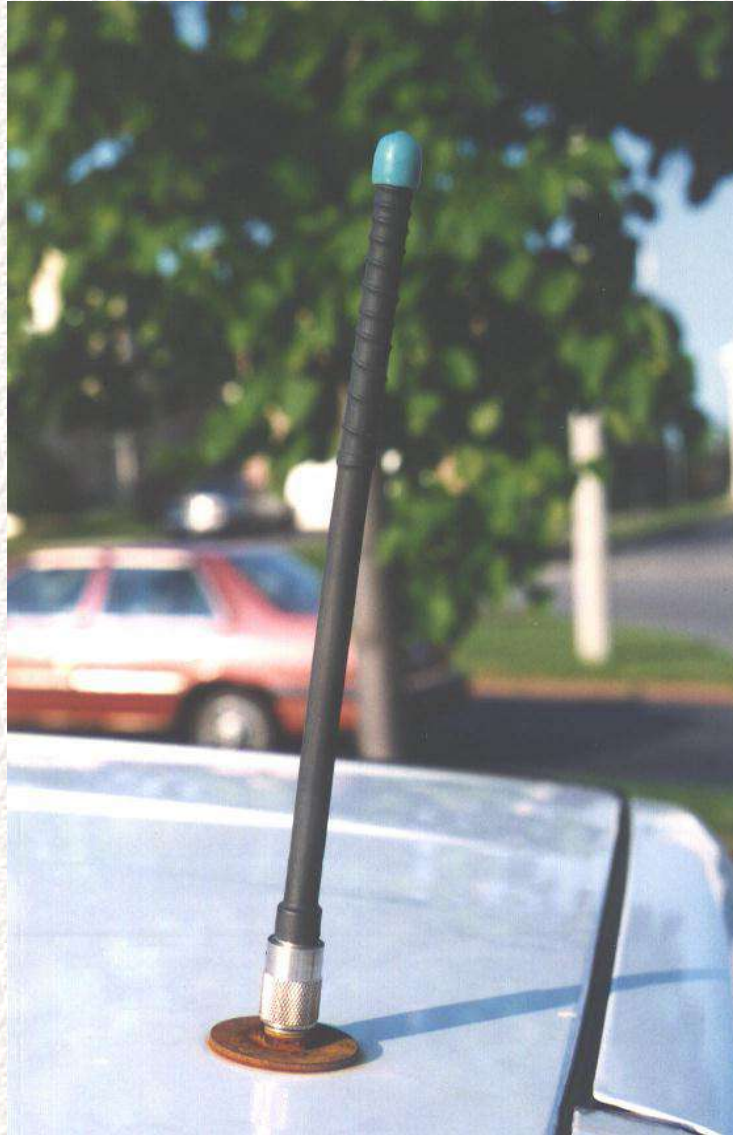

Basic design theory

This antenna is just a $1/4$ wavelength resonator for both UHF and VHF band. It provides no GAIN as compared to other multi-section design. Yet it has the advantage of better stability against surrounding influence (e.g. different mounting method, unexpected reflection by surrounding objects, difference in stray capacitance between test bench and operating field). The antenna consists of two sections. The lower section is a conductor cut to resonant on UHF band. The upper section is a coil which serves two purposes. For UHF band, this coil is a RFC (radio frequency choke). It blocks UHF frequency energy to

flow through upper section. For VHF band, this coil enhances the inductance provided by lower section. The resultant inductor, together with surrounding stray capacitance will form a VHF resonant circuit and becomes the VHF antenna. To get a better understanding on the tune up procedure, it will be helpful to review some basic rules on antennas.

- Antennas are LC circuits. The LC components control their resonant (operating) frequency. Inductive component is formed by metal conductor of the antenna's body while capacitive component refers to stray capacitance between the antenna body and its surrounding grounded conductor.
- Increasing either L or C component can lower the resonant frequency while reducing them causes the opposite effect. Inductor can be increased by adding physical length of the antenna element or by making it as a coiled structure. Capacitance can be increased by using a larger surface area on the antenna body, by adding capacitor hat or by reducing physical clearance between inductive section from ground. In this issue, we mainly alter the inductive section of the antenna to achieve tuning. That is done by cutting length of the conductor and by changing length of coil structure.

Mechanical structure and material consideration

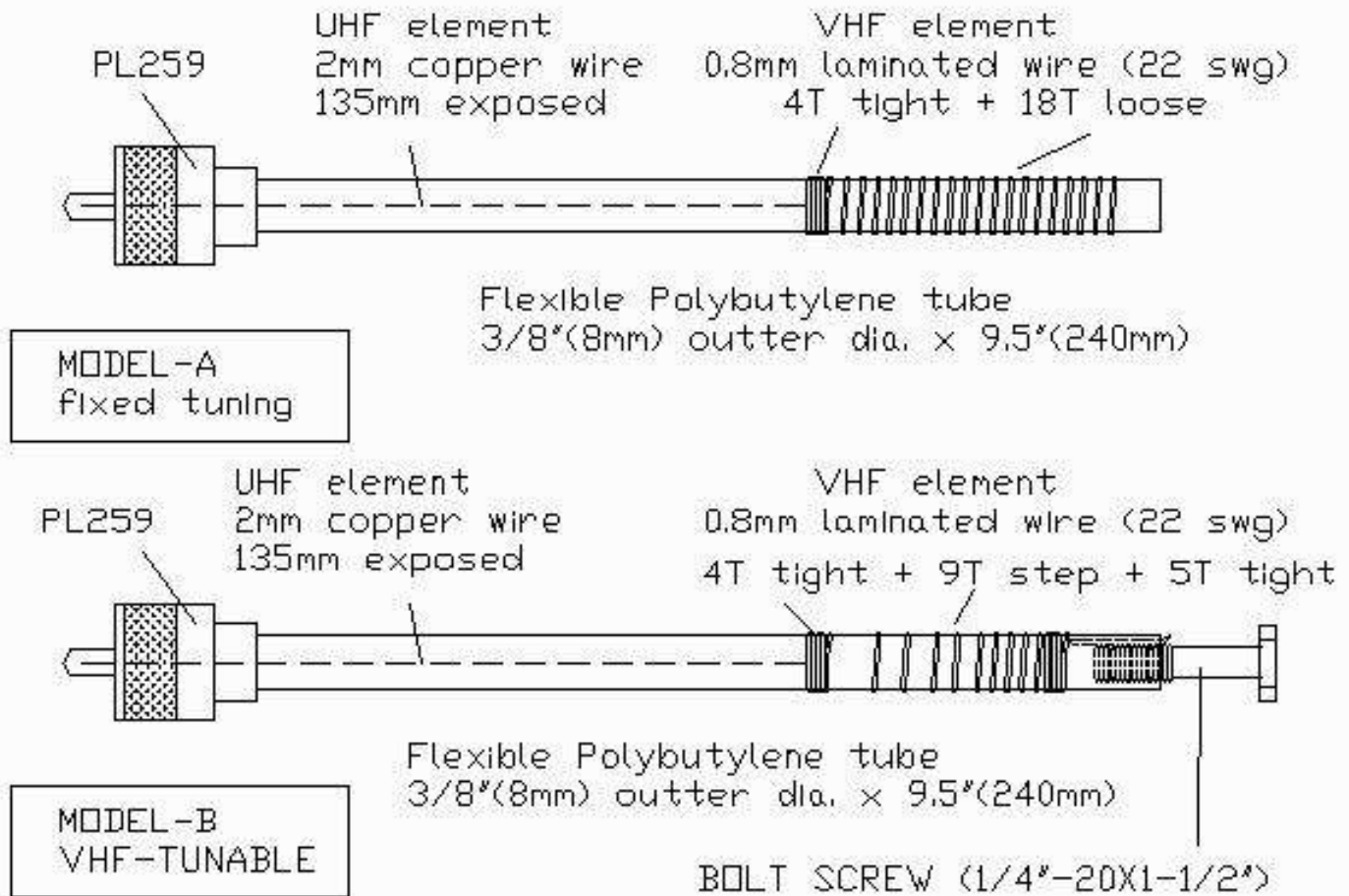
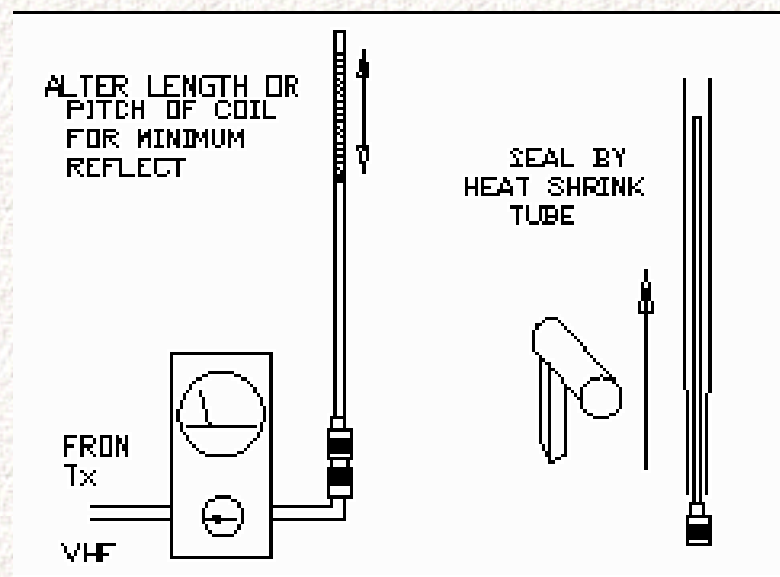

Fig.1 shows two possible structure of this antenna. Model(A) being the fixed style and model(B) being VHF adjustable. The lowest section of the antenna is a PL-259 plug. The center pin of which is soldered to a 2mm diameter copper rod. I got this copper rod from core conductor of RG-8U coaxial cable. It should create an exposed section (clear off from metal shield of the PL-259 plug) of about 135 mm. More detail will be discussed in tune-up section. This copper rod is hidden inside a tube which acts as the coil-form for the upper section. To avoid absorption of RF energy emitted from the antenna, material of this tube must be carefully selected. I used PVC faucet tube for this part. They are polybutylene - those gray color PVC plastic which is cheap and easily obtainable from most hardware stores. You can use any other tubes provided their external diameter can fit into the barrel of the PL-259 plug plus it does not absorb radio waves. We can use a microwave oven to check out if a certain material will absorb R.F. energy. Material placed inside an operating microwave oven will generate heat if they absorb radio waves. Place the material under test inside the microwave oven together with a cup of water (for safety). Execute heating process for say 1-2 minute and check surface temperature of the object under test. If the material stays cool as compared to the cup of water, we can assume that it do not favors radio wave absorption and will be suitable for the job. A small hole (1 mm) is drilled on the tube just besides tip of the UHF section. A piece of laminated copper wire (22 swg) is soldered to the tip of the UHF section and is leaded to outside of the tube through this hole. The rest of this wire is wound on the upper part of the tube and forms the VHF section. After proper tuning is completed, the whole antenna is sealed within a piece of heat shrink coating down to the neck of the PL-259 plug. A rubber cap can be placed on top of the antenna in order to prevent water from entering inside of tube.

Constructing procedure and tune up



Cut out a piece of 2 mm copper rod. Let's starts with a length of about 160 mm. That should cover future cutting job and the length hidden inside the PL-259 barrel which is not counted for radio emission. Insert it into the center pin of the PL-259 plug and make a smooth soldering at the tip of the pin. We now have a UHF antenna. Before attempting to tune it, prepare two pieces of 2 mm copper rods also, they should be of length 140 mm and 500 mm respectively. They will serve as the temporary ground planes for UHF

and VHF test. By using a reflectometer (SWR meter), check out the reflect power from this simple antenna when UHF power is fed. Cut the length of this section slowly (in 2-3 mm step) and observe changes on reflect power at lower end of target frequency band. Without attachment of a good ground plane, it is impossible to obtain zero reflect status so just go for the lowest possible value. Using the low end frequency for testing is a safety precaution. That prevents you from over cutting the antenna without notice. After you felt satisfied with the cutting progress and has slightly over cut the rod (reflect power increase again upon further cutting). Change test frequency to middle of operating band and proceed further cutting with high care. Once reflect power increased again (indicating slight over cut), pick up the earlier prepared 140 mm section and touch it to the PL-259 plug of this antenna. You should see the reflect immediately drops for a lower or even 1:1 value. This confirms that the section is properly cut and is ready. Cut out a piece of faucet tube (240 mm in length). Insert it into the barrel of the PL-259 plug. Make a mark on the tube where it just clear out from the PL-259 barrel. Remove the tube and put it side by side with the UHF antenna while the mark is aligned with the top of the PL-259 plug. Make another level mark for the tip position of the UHF section. Drill a 1 mm hole on the tube at that mark. Prepare for a piece of 1 meter long 22 swg laminated wire . Push it through the above mentioned hole and force it to run through the lower section of the tube until it made its way out from the bottom. Solder this wire to the tip of the UHF section and pull the wire back into the tube. That will bring the UHF section into the tube as well. Pull out any excess wire inside the tube until the tube is seated tightly inside the PL-259 barrel again. Wind the laminated wire on the tube for 22 turns. These turns should be in a pattern as shown in fig.1. The first 4 turns which forms the RFC for UHF band must be tight. The later 18T should be interleaved and evenly spread along until reaching end of the tube. That should make a coil of approximately 80-90 mm in length. Place the antenna on the reflectometer again, recheck the SWR or reflect status on UHF band, there should be no change as compared to earlier test result. Change frequency to lower end of target VHF band and repeat the test. Tune the VHF response of the antenna by altering length and pitch of the 18T section. Generally speaking, start with evenly distributed pitch and try to control the resonant frequency with coil length. If that cannot work out, try to rearrange the pitch unevenly - tighter pitch near the bottom and looser pitch near the top. Such treatment can further lower the operating frequency. Like tuning job in UHF band, go for the lowest possible reflect on the middle spot of your target band and confirm proper tuning by adding of VHF ground plane (500 mm long copper rod). Once both bands are confirmed in tune, seal and secure the whole antenna with heat shrink tube. The antenna is now ready for application at mobile vehicle environment. If you want future tuning possible in order to match different field environment, you can try model(B), the VHF tunable configuration. In that case, another 1 mm hole should be drilled on the tube near top portion of the coil. The 22 swg wire should be leaded back into the inner side of the tube. A section of contact wire 10 mm in length at top end of tube should be formed. A 1/4" metal bolt is screwed in to fill up the tube. Its pitch should bite through the laminated surface of that 22 swg wire and make a contact with the wire. The bolt will become an extension of the coil and by adjusting the bolt length (in/out or even changing length of bolt), the VHF resonant point can be adjusted.

Conversion for base station application

This antenna can be used at base station configuration also. The trick is to provide sufficient ground plane system in order to form those essential stray capacitance for proper tuning. Fig.3 shows a simple

dual-band ground-plane design and corresponding mounting for base station.



This mount can be used with other UHF/VHF mobile antenna design also (as long as they use PL-259 base connector). It is a very good test bench if you have needs to compare efficiency between two mobile antennas or just want to convert another mobile dual band antenna for base station application. The materials for this mount are all easily obtainable pipes and sockets used in electric power installation. We need a piece of electric conduit (metal pipe for protection of electric cable). Length is not critical, say 20" will be fine. It should be of the 0.5" diameter series. These pipe are measured for their inner diameter. Find also the EMT connector (set screw type) for the same family and put them on both ends of the conduit. The reason for using this dimension is because - the inner diameter of such EMT connector will perfectly fit a SO-239 socket (UHF female bulkhead receptacle solder type). You can tap threads on the inner wall of the EMT connector so that the SO-239 can be screwed in. I used a short cut, just hammer the SO-239 into the connector. The only weakness of this method is - the socket cannot be removed easily or frequently. Anything must be done right at the first move and cannot be repeated for correction. By putting two SO-239 socket on each end of the conduit and have them connected inside the pipe, a female to female adapter is formed. The upper socket is for mounting of the antenna, the lower one is for connection of feed line. The length of the conduit serves another purpose - made possible mounting of the whole antenna on another vertical pole easily with two hose-cramps. We also need a piece of 4" round-pan (top cover for those circular shape power junction box). It provides a flat platform where the ground-plane elements can be mounted. The ground-plane elements are made of threaded stainless steel rods (size 10-24). Holes at 60 degree separation are drilled on the vertical edge of this round-pan. The threaded rods can then be mounted through these holes with two nuts (inside and outside the round-pan's edge). Length of ground-plane elements control their resonance frequencies. Different materials needs different lengths to achieve resonance. Our earlier mentioned value 135mm at UHF and 500mm at VHF are only good for copper conductor. For steel, the length will be different. Together with situation that these rods are mounted 2" away from the RF socket, their dimension will be much shorter. Practicle test indicated that UHF ground elements in this design is best at length 70mm while VHF elements at 350mm. This length refers to rod's length between their tips and mounting point at round-pan. Since these rods are mounted with two nuts, their effective length can be adjusted. To play

safely, the rods should be cut with 30mm extra length. That comes out as 100mm for UHF and 380mm for VHF. Adjusting procedure on their final length will be discussed later. The SO-239 connectors has to be connected inside the conduit. I made a mistake at the beginning. Feeling that both sockets are tightly hammered and in good contact with the pipe, their ground points should have been connected nicely. I used only single core wire to connect their center pin rather than using coaxial cable to join them. But I forgot one thing, the two EMT connectors were secured on the metal pipe with only two set screws ! That is not a good contact for radio waves. I was surprised by the test result of such prototype - SWR reading of nearly 1.8:1 even with proper 50 ohm dummy load terminated. After modifying the connection back with standard RG-58AU cable, SWR for this section normalized to 1:1. Drill six holes on the edge of the 4" round-pan and punch out the center hole on the top surface. Mount the round-pan on the upper EMT connector, Secure it with the nut which comes with the connector. Cut threaded rods to proper length (three at 100mm, three at 380mm) and have them mounted on round-pan in alternate pattern. One UHF element followed by a VHF element then vice versa.



Construction of the mount is now almost finished (awaiting final tune up). It is not a bad idea to paint the whole thing - for protection against water damage in future. Try to do it after all ground-rods are set. We need good metal contact surface between the round-pan and the rods. Tuning of ground-rods are similar to tuning of main element. The longer the length, the lower the resonance frequency. Since we have three rods for each band, we can set one rod on the lower frequency limit, one on high limit and one for the center spot. This will create a flatter response of the antenna in the entire operating spectrum. Always remember to work on one rod at a time (with the other five removed). Set up one test frequency and alter the rod's length for minimum reflected power. Then mark the length and change for another rod

with another test frequency. Put them back onto the round-pan with proper tested length after all key spots (three for VHF and three for UHF) are checked out. Reflection from near by objects can distort the above measuring result. These tests must therefore be done in open space, try to obtain clearance of at least 5 meter from any objects which might cause reflection. Always try to use high quality feed-lines to avoid creation of fake image of low reflection when reflected power are absorbed.

[More detail on this antenna can be found in Radio Fun May 1994.](#)

[Return to Dreamland](#)

[VE3GK.COM](http://www.ve3gk.com)..WELCOME, FROM GERRY KING VE3GK

>> [HOME](#)<< >> [RETURN TO FRONT PAGE](#)<<

WELCOME TO VE3GK, GERRY KING'S HOMEBREW HAM STUFF AND PUBLISHED "GAIN GAME" AMATEUR RADIO ARTICLES

AT THIS TIME I DON'T HAVE A GUESTBOOK SO PLEASE CLICK ON MY EMAIL
address AND SAY HELLO AND I WILL MAIL YOU RIGHT BACK...THANKS

ve3gk@rogers.com

DON'T BE CONCERNED IF YOU FIND A LINK NOT WORKING ON THE SIDE FRAME
....IT IS CONSTANTLY BEING WORKED ON THANKS



THE TWO IMAGES ON THE LEFT ARE
OF THE NEW 1.5 TON TOWER
CONTROLLER...MORE COMING JAN
25,2002

[MATTS SUB](#)

[THE SKYNEEDLE TOWER](#)

LAST UP-DATE ,05/04/01---

[7 HF
AMPLIFIERS and](#)

[4 HF
TRANSCEIVERS*](#)

[WIRE
ANTENNAS](#)

[THE INVERTED
VEE ANTENNA
RE-VISITED](#)

[INVERTED VEE
BEAM FOR THE
80 METER BAND](#)

[SPECIAL QUAD](#)



[4X4 STACKS 30 FT BOOMS ON 2.5
TON FREESTANDING ROTATING
TELESCOPING GK HB SKYNEEDLE](#)



[THE 6 ELEMENT ANTENNA PARTY](#)



[ROTATING FULL SIZE 80 METER 2
ELEMENT QUAD FREESTANDING AT
125 FEET 40 FEET FRONT TO BACK
SPACING](#)

[80 METER 2 EL ROTATING QUAD](#)

[MOBILE MOTORIZED HF ANTENNA](#)

[3-30 MHZ MOTORIZED MOBILE ANT](#)

[YAGIS STACKING](#)

[QUARTER-WAVE COAX](#)

[MATCHING HARNESS FOR UP-TO 4 STACKED BEAMS*](#)

[YAGI STACK SEPARATION TEST](#)

[INTRODUCTION](#)

[THE STACKED ARRAY](#)

[MATCHING AND PHASING HARNESS FOR STACKS TOP-BOTTOM-STACK TESTS*](#)

[REMOTE, TOP-BOTTOM-STACK SWITCHING](#)

[STACKING TRI-BAND YAGIS](#)

[3X3 GK stacks rotating tower](#)

[MODIFYING THE 204BA](#)

[6 EL 20M YAGI ANTENNA PARTY](#)

[THE 50 FT BOOM 5 EL 20M YAGI ON IT'S WAY UP TO 100 FEET](#)



[CONTEST HF AMP 2, 4CX1000A IN PARALLEL VACUUM EVERYTHING](#)

6 EL 20M YAGI ANTENNA PARTY (note: the reflector is on the ground) 60 FT LONG 4 IN DIA BOOM



[HIGH RANGE PL172, 1.5 KW HF CONTEST AMP](#)



THE RED 4CX1000A HF AMP

[LAST UP-DATE, 07/23/02](#)

[HF TRANSCEIVERS](#)

[1.5 TON STEALTH TOWER](#)

[winch in the winter](#)

[LETS TALK ANTENNAS AND TOWERS*](#)

[The gain game caper eh!](#)



[CLICK HERE FOR HB 20 METER 4X4 STACKS, 40 FT BOOMS, ON LARGE TELESCOPING ROTATING 2.5 TON TOWER](#)

[THE STEALTH SKYNEEDLE](#)



UP 100 FT

[THE COMPLETED 4X4 20M STACKS ON THE 2.5 TON TELESCOPIC ROTATING SKYNEEDLE](#)



DOWN 28 FT



[4X4 20M STACKS ON A MODIFIED LATTICE TOWER 90 FT AND 40 FT](#)

[THE BRONTOSAURUS 20METER GUN](#)

[4,5,6 and 7 element 20m VE3GK yagis](#)

[LAST UP-DATE ,07/23/02-](#)

[85 MORE PHOTOS](#)



[MY SON MICHAEL WORKING ON THE BIG TOWER SEE HIS WEB SITE CLICK HERE.](#)

[2.5 TON 115 FT SKYNEEDLE ROTATOR AND 2 HP HOIST](#)

[THE 50 FT BOOM 5 EL 20M YAGI ON IT'S WAY UP TO 100 FEET](#)

[SPECIAL PROJECTS](#)

[204BA CONVERSION TO THE 204GK**](#)

[YAGIS](#)

[4 EL 20 M YAGI](#)

[6 EL 20 M YAGIt](#)

[5 EL 20 M YAGI](#)

[7 EL 20 M YAGI](#)

[4X4 20 M STACKS 1](#)

[4X4 20 STACKS 2](#)

[HOW ANTENNA TRAPS WORK](#)

[20 M STACKS AND ROTATING TOWERS](#)

[HB SKYNEEDLE TOWER 2.5 TONS](#)

[1.5 TON 80 FT SKYNEEDLE ROTATOR-TILT-OVER- HOIST](#)

[20 METER 4X4 STACKS 42 FOOT BOOMS ROTATING 90 FOOT LATTICE TOWER](#)

[BIG TOWER ROTATORS](#)

[ROTATING LATTICE TOWERS](#)

[HF AMPS](#)

[A...4CX1000A 6 METER](#)

20M GK YAGIS

4 el, .. 5 el, .. 6 el, .. 7 el *

204BA CONVERSION TO THE 204GK**

TIPS ON HOW TO EXTEND THE LIFE OF TRANSMITTING TUBES*

7 HF AMPLIFIERS and 4 HF TRANSCEIVERS*

GUYS FOR GUYS AND GALS WHO HAVE TO GUY

THE "RSQ" SIGNAL REPORT A NEW WAY TO REPORT ON RECEIVED SIGNALS don't read this

THE DB CAPER

HOW ANTENNA TRAPS WORK

GAIN GAME CAPER.. lets talk antennas, towers and rotators

THE INVERTED VEE ANTENNA RE-VISITED*

INVERTED VEE BEAM FOR THE 80 METER BAND

SPECIAL PROJECTS

STACKING TRI-BAND YAGIS

THE GK HOCKEY PUCK NOISE SUPPRESSOR FOR YAGIS

20 METER 4X4 STACKS*

YAGI STACK SEPARATION TEST

REMOTE, TOP-BOTTOM-STACK SWITCHING

GAIN GAME STUFF*

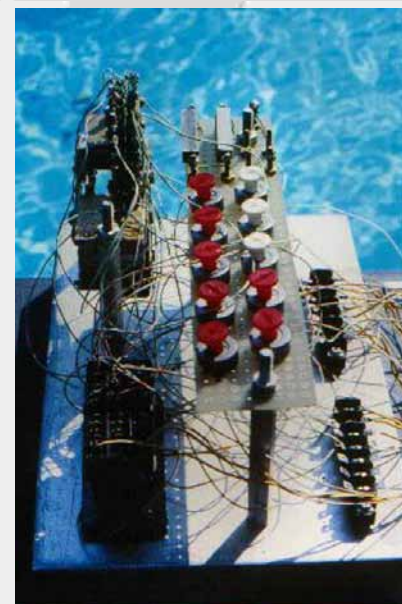

LINEAR TO CIRCULAR ROTATOR

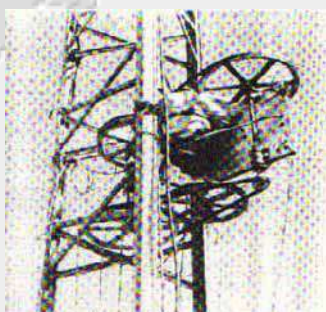

VEE BELT ROTATOR



MAG MOUNTED MOTORIZED 3 TO 30 MHZ < 1.1 TO 1 VSWR WITH NO EXTERNAL L/C COMPONENTS THIS IS NOT A COMPROMISE SCREWDRIVER ANTENNA

2.5 TON 115 FT SKYNEEDLE ROTATOR AND 2 HP HOIST

ve3gk@rogers.com

VHF-HF-UHF REMOTE CONTROL BEAM CONTROLLER

ve3gk@rac.ca

NB:

If you build anything, follow the technical info, if you change the info the results may not be positive.. GER

+

Please follow good safety rules when you climb towers and work with high voltage power supplies.



BUILDING THE TOWERS ^ ^

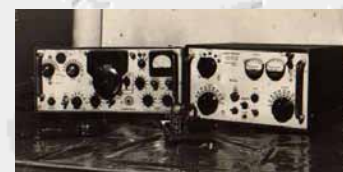

[B,,,4CX1000A HF.TABLE TOP](#)

[C,,,4CX1000A MINI SIZE](#)

[D,,,4CX1000A](#)

[E,,,4CX1000A](#)

[F,,,4CX1000A](#)

[G,,,4CX1000A A PAIR 1.5-30MHZ CONTEST AMP](#)

[PLI72 1.5 KW](#)

[PLI72 STATION](#)

[4X150D AMP AND HF TRANSCEIVER](#)

[4CX1000A AND HF TRANSCEIVER](#)

[HF TRANSCEIVER](#)

[7 HF AMPLIFIERS and 4 HF TRANSCEIVERS*](#)

SPECIAL PROJECTS

MISC PROJECTS

[GUESS WHO ONTHE BOOM](#)

[THE GK HOCKEY PUCK NOISE SUPPRESSOR FOR YAGIS](#)

QUARTER-WAVE COAX MATCHING HARNESS FOR UP-TO 4 STACKED BEAMS*

MATCHING AND PHASING HARNESS FOR STACKS TOP-BOTTOM-STACK TESTS*

don't skimp on the stack separation

[GK HF STATIONS](#)

A LOOK AT THE DX LOCATION CLICK HERE



Guess who on the boom



VE3GK 20 DB, HF, 160 TO 10 METER AMP USING TWO 4CX1000A CERAMIC TUBES

[Building the big tower in the shop](#)

TUNED TWO METER CAVITY, BAND PASS FILTER TO REDUCE INTER-MOD

3-30 MHZ MOTORIZED MOBILE ANT

[PL172 HIGH RANGE CONTEST CONTINUOUS DUTY 3 TO 30 MHZ AMPLIFIER](#)

GK HF TRANSCEIVER + 1 KW AMPLIFIER miniature

[THE 50 FT BOOM 5 EL 20M YAGI ON IT'S WAY UP TO 100 FEET](#)

THE 5 ELEMENT YAGI CAPER

BIG TOWER OUT FOR MAINTENANCE... SOCKET IN THE BACKGROUND

4EL 20M GK YAGI 40FT BOOM

[My son Michael, above, working on the 2.5 ton big tower, nested, 118ft when extended](#)

GK HF STATION 3-30 MHZ TRANSCEIVER + 4CX1000A AMPLIFIER

3X3 GK stacks rotating tower

CHANGING A SLAVE HOIST CABLE

LINEAR TO CIRCULAR HEAVY DUTY ROTATOR

[The stacked array ant direction controller](#)

BIG TOWER REMOTE SAFETY CONTROL

RELAY SYSTEM



HOMEBREW GK HF STATIONS



THE BIG TOWER NESTED ST 28 FT...MY SON MICHAEL WORKING FROM THE WORK TOWER, CHANGING ONE OF THE OMEGA MATCHES

GUEST SPOT#2

[F6DMQ.... STACKING TWO KT34XA YAGIS ON A UNIQUE ROTATING TELESCOPING ROTATING TOWER](#)



PICTURE OF HALF DEPLOYED HDX 589 TOWER

PLEASE SEND ME IMAGES OF YOUR HOMEBREW STUFF 73 GER VE3GK

[GUYS FOR GUYS
AND GALS WHO
HAVE TO GUY](#)

[TIPS ON HOW TO
EXTEND THE LIFE
OF TRANSMITTING
TUBES](#)

[HOW ANTENNA
TRAPS WORK](#)

[GK HF STATIONS](#)

[A LOOK AT THE DX
LOCATION CLICK
HERE](#)

[CHANGING A SLAVE
HOIST CABLE](#)

[The stacked array ant
direction controller BIG
TOWER](#)

[Building the big tower in
the shop](#)

[TUNED TWO METER
CAVITY, BAND PASS
FILTER TO REDUCE
INTER-MOD](#)

[My son Michael,
above, working on the
2.5 ton big tower,
nested, 118ft when
extended](#)

[LINEAR TO CIRCULAR
HEAVY DUTY ROTATOR](#)

[BIG TOWER OUT FOR
MAINTENANCE...
SOCKET IN THE
BACKGROUND](#)

[MOTORIZED MAG MOUNT
MOBILE ANT. NO
INTERMEDIATE LC
NETWORKS <1.2/1, 3-
30MHZ *](#)

[GAIN GAME STUFF*](#)

BIG TOWER ROTATORS

**MOTORIZED MAG MOUNT
MOBILE ANT. NO
INTERMEDIATE LC NETWORKS
< 1.2/1, 3-30MHZ ***

**6 EL 20M YAGI 58 FT BOOM you
think the antenna is big you
should see the size of the TV set**

4X4 20m stacks

3X3 20m stacks

**4X4 20 M STACKS HB
SKYNEEDLE TOWER**

2.5 TONS

[back to the top](#)

**BUILDING THE 1.5
TON TOWERS^**

[Z](#)

**TOWER REMOTE
SAFETY
CONTROL RELAY
SYSTEM**

[**back to the top of the
frame**](#)

HF MOBILE ANTENNA (HB9ABX)

Felix Meyer

update 27th May 2003 / details July 27, 2004

This mobile antenna is designed for all HF bands from 10 to 80 meters and proved to be very efficient in my travels in South America on 15 and 20m for contacts to Europe and within South America.

The antenna is my own development.

Compared to commercial HAM Antennas the performance was always much better, due to the larger size and lower loss in coil.

Comparing with the Screwdriver type antennas always resulted in 2-4 S-points advantage in favor of this antenna!

In field tests we compared 3 different mobile antennas, all at the same location, at the same time, each one with 100 W power.

The 3 antennas were:

- **HUSTLER mobile antenna (10 - 80 m)**
- **YAESU ATAS-100 (10 - 40 m)**
- **HB9ABX mobile antenna (10 - 80 m)**

In all tests the signal of the home made antenna was the strongest!

- **1 S points (up to 10 db) stronger than HUSTLER**
- **2 to 4 S points stronger than ATAS-100/ATAS-120**

These results in the ground wave (5 to 10 km), as well as in the far field at 70 km to 1000 km distance.

For 10, 15, and 20 m the antenna consists of a fixed lower part and an extensible whip (telescopic antenna of 15 to 80 cm length) on the top.

For 20, 40 and 80m a second segment is added and at the top follows the whip.

Both parts are made of fiberglass rod of 10 mm diameter and 175/165 cm length, on which a piece of enameld copper wire (CuL) of 1.5mm diameter is wound. Aluminium tubes are used to join the parts together.

On both fiberglass rods equally spaced windings of enameld copper wire of 1.5 mm dia are wound. The lower part holds 320 cm wire (79 turns) and the upper part holds 470 cm wire (120 turns).

The loading coil is wound on a plastic tube of 7.5cm diameter and 17 cm length.

The same type of wire (1.5 mm CuL) is used for the coil as for the antenna.

The coil has 33 turns in total, coil length is 12 cm.

Seen from the bottom of the coil, there are taps at 21, 27, and 33 turns,

which are shorted according to the operating frequency.

Settings of the antenna in operation:

10m : Lower part + whip + tap 3 + bridge from tap 3 to the whip

15m : Lower part + whip + tap 3

20m : Lower part + whip + tap 2

20m : Both parts + whip + tap 3

40m : Both parts + whip + tap 1

80m : Both parts + whip + no tap (full coil)

The WARC bands 30, 17, and 12 m can be operated by just adding coil taps without changing the coils.

Feeding:

The antenna is fed by 50 Ohm coax (Type RG 58) of about 2 m length.

On the antenna side the center conductor of the coax is connected to the antenna wire and the coax braid is connected to the car chassis ground.

**The antenna system requires a good ground !
I soldered a flexible wire at both sides inside the door frame leading to the coax braid.**

Don't forget to connect the two windings on the fiberglass rod together, either through the metal sleeve between the rods, or simply by a connector. The whip on the top is connected to the end of the wire below.

The desired resonance frequency is adjusted by changing the length of the whip on top of the antenna. Extending the whip lowers the frequency.

**The antenna requires an antenna tuner for operation, as the impedance differs from 50 Ohms on 40 and 80 m.
With the aid of the tuner, the antenna is adjusted to SWR 1.0 on all bands.**

The MFJ-901B tuner is fine for this use. It has little weight and is very small (12.5 x 5 x 15 cm).

(Before its use it's recommended to open it to check the adjustment of the variable capacitors. They are frequently bad centered, which produces easily shorts ...)

If the transceiver and tuner are without SWR meter then a separate instrument is to be connected between TX and tuner. I am using a DAIWA CN410M which is a small cross needle instrument best suited for this use.

Mounting of the antenna:

I installed the antenna on top of the car on a roof carrier. Two aluminum angles, 30 cm length, 30mm thigh, were fixed with screws to the carrier and the rod below the coil fixed to the angles by means of two hose clamps.

Instead of the Aluminium tubes copper tubes may be used, whatever is found to be better. The tubes are glued in 5 cm length over the fiberglass rod. At the end of the 7 cm open part of the tube, a 2 cm long slot is sawed and a small clamp is used to hold the inserted antenna part .

The antenna is directed backwards at an angle of abt. 70 degrees. In order to prevent swinging up, the antenna is fixed slightly down at the end with a nylon rope. Use 2 nylon ropes, to both sides to prevent swinging sidewise when driving. This is required when both antenna elements are installed.

The top of the antenne nearly reaches 3.2 m height above ground when both elements are in use and fixed by a nylon.

Adjustment hints:

Initially, the antenne has te be tuned to resonance on each band without using the tuner.

This adjustment is done by changing the coil tabs and then varying the spacing between turns.

In operating mode, only the tab setting is changed, the whip length set, and tuned with the tuner.

Before initial adjustment, both elements have to be checked: [click here](#)

The initial adjustment is done by using an antenna analyzer (e.g.MFJ-259). Resonance is found by obtaining minimum SWR on the instrument.

Procedure of initial adjustment : (this is done without tuner)

Lower part + whip (10 to 20 m)

- Coil tap 3 (= all turns closed)

Adjust length of whip to obtain min. SWR at 21.2 MHz.

Note length of whip. This is the 15 m setting.

- Coil tap 2 (27 turns closed)

Keep length of whip from previous setting.

Adjust spacing of the upper 6 turns to obtain min. SWR at 14.2 MHz.

Fix coil, this is the 20 m setting.

- Coil tap 3

Make a bridge using a flexible wire of 150 cm length with clips between tap 3 to whip connection (wound 2 - 3 times around rod).

Adjust length of whip to reach min. SWR at 28.4 MHz.

Note length of whip. This is the 10 m setting.

Both parts + whip (20 to 80 m)

- Coil tap 3

Adjust length of whip to reach min. SWR at 14.2 MHz.

Note length of whip. This is the 20 m setting.

- Coil tap 1

Measure SWR on 7.05 MHz and adjust spacing of coil between taps 1 and 2 to reach minimum SWR. Change length of whip only, if minimum SWR remains outside indicated frequency.

Fix coil and note length of whip. This is the 40 m setting.

- Coil without tap (33 turns active).

Keep length of whip and measure SWR on 3.7 MHz.

Adjust spacing of coil of the first 21 windings to reach minimum SWR.

Change length of whip only, if min. SWR remains outside 3.7 MHz.

Fix coil and note length of whip. This is the 80 m setting.

After terminating this adjustment the coil winding is fixed permanently.

After this initial adjustment, the tuner is connected to match the SWR exactly on operating frequency.

With my antenna the SWR without tuner on 10, 15, and 20 m is better than 1.2 therefore tuning is only required for 40 m and 80 m operation. This however depends from the actual installation, especially from the ground connection.

See further details from the following drawings:

[Drawing 1 \(lower part\)](#)

[Drawing 2 \(upper part\)](#)

The photograph below shows the installed antenna in Chile as CE3CWF/mobile. (The white antenna is a 2m antenna)

Good luck in construction.

For additional questions: [see here](#)

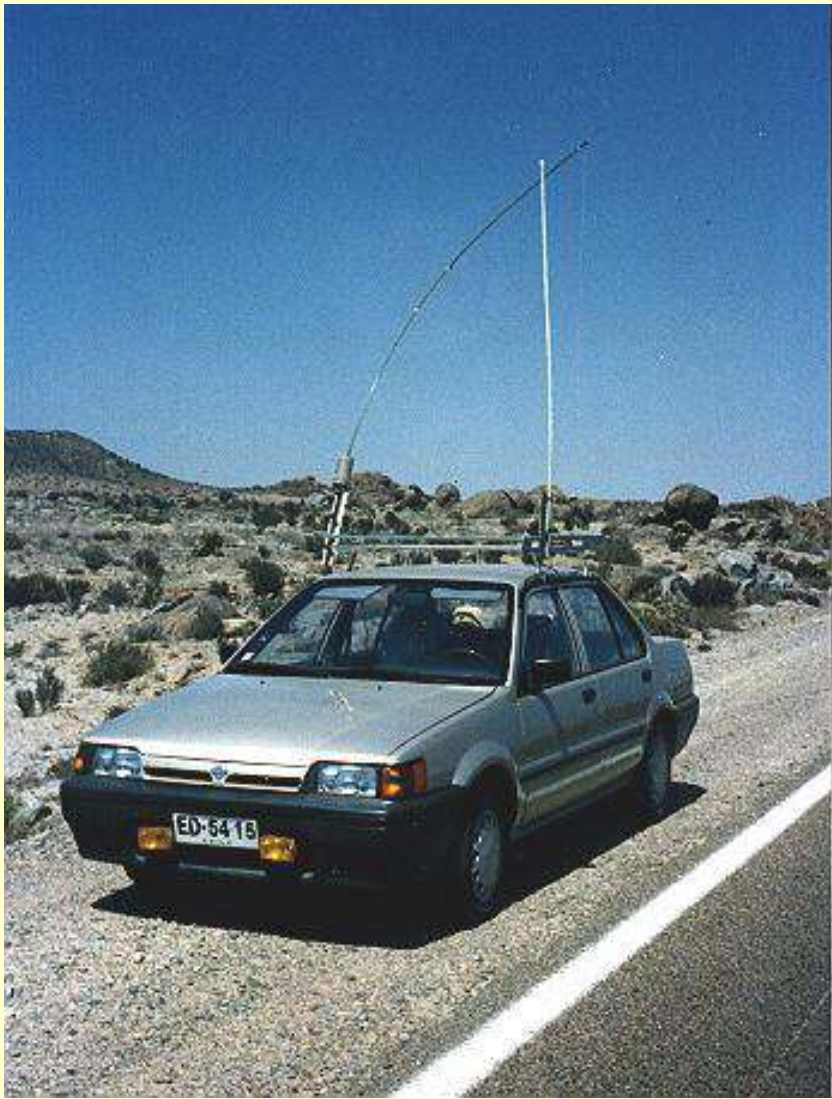

my antenna as CE3CWF

Below the mobile antenna in Switzerland as HB9ABX:



And finally the mounting of the antenna on the roof of the car:

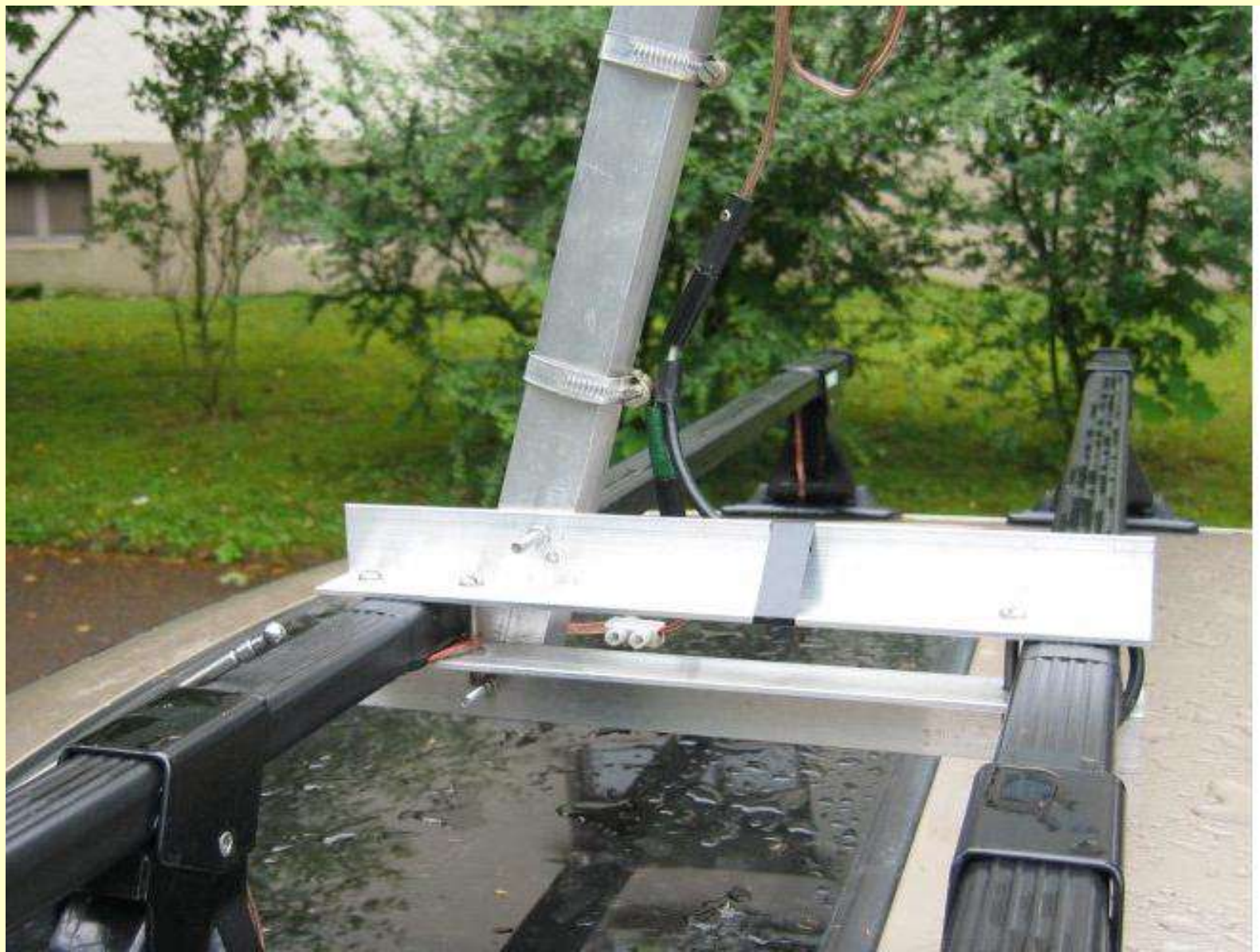

WARNING

Working with fiberglass rods produces dangerous dust, which easily produces allergies on the hands. Inhalation of the dust is extremely dangerous !

Already holding the raw bars with the hand can produce problems, therefore use protecting gloves

whenever working and handling raw fiberglass rods and observe appropriate care when sawing.

Wash well the hands with soap after the work !

After terminating the work paint the complete rods with a suitable lacquer to protect the surface.

[BACK](#)

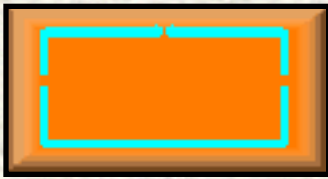

Moxon Rectangles



L. B. Cebik, W4RNL

The Moxon Rectangle is growing in popularity as a compact 2-element array that approaches a full-size 2-element in gain but with a far superior front-to-back ratio and a direct match for the standard 50-Ohm coaxial cable. The antenna can be built as a wire array--especially for the lower HF regions--or as a rotateable aluminum beam. For convenience, I have pulled together the growing selection of Moxon Rectangle notes into this single subdirectory and organized them in the order of recommended reading--unless you already know what you are looking for.

- [VK2ABQ Squares and Moxon Rectangles](#) (7-25-99)
- [The Moxon Rectangle: A Review](#) (12-18-99)
- [An Aluminum Moxon Rectangle for 10-Meters](#) (4-6-98)
- [Wire Moxon Rectangles for 40-10 Meters](#) (1-1-97, 6-10-99)
- [Further Notes on 40-Meter Wire Moxon Rectangles](#) (5-4-99)
- [Notes on the Moxon Rectangle Pattern](#) (2-22-2000)
- [The Double-D Antenna](#) (3-18-97, 5-4-99)
- [Multi-Banding the Moxon Rectangle](#) (8-12-99)
- [The Moxon Rectangle on 2 Meters](#) (10-01-99)
- [Building a 2-Meter Moxon](#) (12-18-99)
- [Designing Moxon Rectangles by Equation and by Model](#) (10-01-2000)
- [40 + 30 = 50 \(Not 70\)](#) (10-23-2001)

- [A Truly Portable Moxon Rectangle for Nearly No-Tool Field Assembly](#) (02-01-2003)
- [Moxon Rectangles for 6 Meters](#) (02-03-2003)
- [The Elusive Moxon Nest](#) (06-01-2003)
- [Part 1: Vertically Stacking Horizontally Oriented Rectangles](#) (12-04-2003)
- [Part 2: Vertically Stacking Vertically Oriented Rectangles](#) (12-04-2003)
- [Understanding the N0KHQ Coax Square](#) (12-08-2003)

Additional information on building wire and tubing versions of Moxon rectangles for a direct 50-Ohm feed is available in *Simple and Fun Antennas for Hams*, ed. Hutchinson and Straw (ARRL, 2002), pp. 12-19 to 12-28. The [KD6WD Moxon Antenna Project](#) at Murray State University is another good source of information on various construction techniques, especially for the operator needing a light-weight or a semi-stealthy antenna.

MOXGEN: A stand-alone Windows program that calculates the dimensions of a Moxon rectangle for a near-50-Ohm feedpoint impedance, as described in "Designing Moxon Rectangles by Equation and by Model," has been developed by Dan Maguire, AC6LA. You may obtain a free copy from his website: <http://www.qsl.net/ac6la/moxgen.html>. The program will also create a model in .EZ format for use with EZNEC or in .NEC format for use with NEC-Win software or with generic NEC programs. The only required input entries are the design frequency and the diameter of the wire or tubing to be used. Dan's site also contains a number of other very useful programs for modelers and others interested in antenna design and analysis.

Below is a version of the Moxon dimension calculator that you may use right on this page, thanks to Joe Faber, KG4UHP, who created the JavaScript and gave me permission to place it here. Remember that the dimensions apply to Moxon rectangles that use the same diameter material throughout. Decide on the design frequency and the diameter of the elements. You may use inches or millimeters for the diameter--or you may select an AWG wire gauge. Be certain to select the unit of measure for the output. Then, click on any of the output boxes if the calculations have not already appeared.

Moxon Rectangle Dimension Calculator

Frequency : MHz

Wire Diam :

Output Units :

A

B

C

D

E

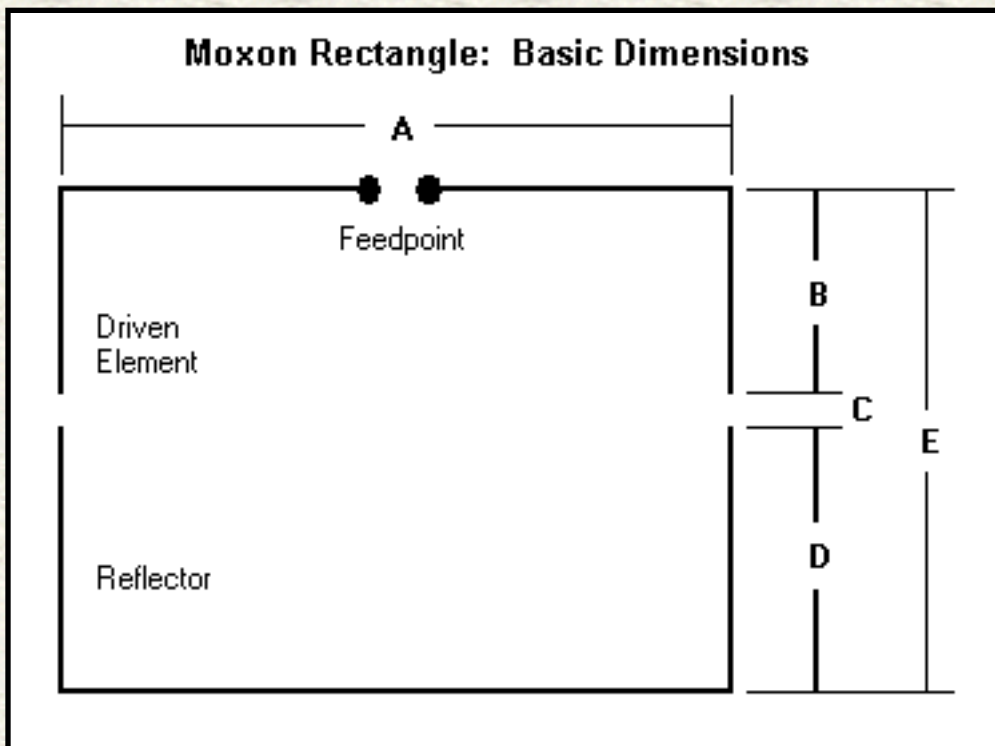

Updated 12-08-2003. © L. B. Cebik, W4RNL. Data may be used for personal purposes, but may not be reproduced for publication in print or any other medium without permission of the author.



[Return to Amateur Radio Page](#)

[Background](#)

[Participants](#)

[Design](#)

[Construction](#)

[Performance](#)

[Msg Board](#)

[Links](#)



The aim of this website is to share the experiences of MOXON antenna builders everywhere. It's all about Hams Helping Hams which is the overlying theme of the MOXON Antenna Project.

The MOXON is a stealthy gain antenna that can be easily home brewed for a small investment. This antenna can be mounted on a simple push-up mast and rotated by hand or with an inexpensive light duty rotor. It should be especially attractive to hams who want to avoid purchasing more expensive towers, rotors and directional antennas.

We invite you to click on the various links at left to learn more about the project.

73,

Moxon Antenna Project Participants

p.s. Want to include your MOXON on this website? Just email your construction notes, performance observations and photo attachments to the website author *Don Snodgrass, K4QKY*.



Click [HERE](#) to post an email to the MOXON message board

What's new

 **6 meter MOXON inquiry and response added to the MOXON Message Board.** [Click here.](#)

 **W3CRR 20 meter "yagi style" aluminum tubing MOXON.** [Click here.](#)

 **9A2TD 20 meter MOXON.** [Click here.](#)

 **New posts on the MOXON Message Board.** [Click here.](#)

 **N2YET modified 17 meter MOXON.** [Click here.](#)

 **9Y4DD 20 meter MOXON.** [Click here.](#)

 **DF4RD provides preliminary info on his 12/17 meter "HEXMOX"** [Click here.](#)

 **Inexpensive source for Crappie fishing poles (spreaders) found.** [Click here.](#)

 **MOXON message board added to website.** [Click here.](#)

 **F5MAG multi-band hybrid MOXON.** [Click here.](#)

 **N5GLR 20 meter hybrid Coaxial MOXON.** [Click here.](#)

 **YU1QT 6 band hybrid MOXON. (recently updated)** [Click here.](#) YU1QT has also built a 3 element 40 meter MOXON which you learn about by [clicking here.](#)

 **W1ZY 40 meter MOXON.** [Click here.](#)

 **KA4SDU 17 meter Bamboo MOXON.** [Click here.](#)

 **K06HL 3 element Hybrid MOXON.** [Click here.](#)

[Free Web Counters](#)

[Kohls Store](#)

MOXON Antenna Project web pages hosted courtesy of
[Murray State University Amateur Radio Club](#)



Site Author: Don Snodgrass, K4QKY
<http://webpages.charter.net/donsno>



Petlowany Three-Band Burner Antenna

June 23, 2002

The *Petlowany Three-Band Burner* is a simple, low-cost, trapless short vertical antenna which amazingly works on three HF bands (20, 15 and 10 meters). This web page contains pictures, performance data, and enough construction details so you can "homebrew" your own.



Petlo... Who?

A ham named Bill Petlowany (K6NO) published an article in the March 1998 issue of *Worldradio* magazine, reporting some interesting results from placing spiral coils on the ends of antennas. A handful of others have experimented with these peculiar antennas. (Another article by W. Caldwell (WA8ABE) appeared in the June 1999 issue of *Wires and Pliers*.) I kept *Petlowany* in the name of my variant in honor of the original experimenter, and called it a *burner* because of its shape.



Basic Description

Fundamentally it's a quarter wave ground plane with 4 radials cut for 15 meters. The interesting twist is the spiral coil "hat" on top, which makes the antenna resonant on 20 and 10 meters as well. The higher wires you see in the picture are guy wires, broken into small enough pieces that the RF doesn't see them. They're not really part of the antenna, electrically speaking.

Performance-wise, it is pretty much indistinguishable from a quarter wave ground plane vertical on all three bands. As such, it does a reasonable job of delivering the low angle radiation required for DX operation.



SWR Measurements

Here are some SWR charts, to demonstrate the antenna's performance on various bands. These are actual measurements of the antenna pictured.

Here are the three bands that give the *Petlowany Three Band Burner* its name.

- [SWR chart for 20 meters](#) (1.4:1 at 14.0, 1.2:1 at 14.5)
- [SWR chart for 15 meters](#) (1:1 at 21.0, 1.1:1 at 21.5)
- [SWR chart for 10 meters](#) (1.2:1 at 28.0, 2:1 at 29.3)

Here are two more bands that will at least accept power. Performance isn't great on these bands, but it's usable in a pinch.

- [SWR chart for 80 meters](#) (2:1 at 3.5, 2.5:1 at 4.0) SWR is high but it won't cook your finals. For an antenna this short to do *anything* on 80 is pretty nifty.
- [SWR chart for 2 meters](#) (1.1:1 at 144, 1.5:1 at 146) Don't let the low SWR fool you. The vertical is so long for 2 meters that most of the energy goes up at a 60 degree angle.



Construction Details

Following are detailed instructions for building the antenna as I have built it. Naturally many other types of construction are possible, and different dimensions could yield antennas that work on other frequencies.

Parts List

Most everything can be found at a hardware store and a radio shack.

- 12 feet of 1/2 inch PVC pipe (thicker variety preferred)
- one 1/2 inch PVC cross
- one 3/4 inch PVC male plug
- 5 meters of 12 ga. wire (recommended: stranded, insulated)
- 20 cm of 3/4 inch copper pipe (as above, the thicker kind is apt to be stronger)
- two 3/4 inch copper male adapters

- two 3/4 inch copper pipe mounting brackets
- one 10 foot length of one inch copper pipe (In hardware stores, two grades are available. Get the thicker one, "blue" or "type L")
- one 1 inch copper male adapter
- one 3/4 inch thread to 1 inch copper male adapter
- 2 radio shack guy rings
- a few feet of solid wire (14 ga or 12 ga, not critical)
- one 5 foot galvanized pipe (one inch) with threaded ends
- two inches of one inch PVC pipe (thicker variety preferred)
- two 1 inch PVC female adapters
- 20 meters of 12 ga. wire (I used stranded, bare wire from radio shack, but the exact type is not crucial)
- 100 feet of steel guy wire (available at radio shack)
- 1 radio shack roof apex antenna mount kit
- lag screws suitable for attaching roof mount to roof
- roof tar to seal over roof mount
- 4 large hooks for guy wires (available at radio shack or hardware store)
- coax



Making the spiral top

Click the picture above for a more detailed view.

The spiral coil is wound on a form built of half inch PVC pipe. The first step is to make the coil form. Cut four pieces of half inch PVC 20 cm long. Insert one of them into the half inch PVC cross as far as it will go. Make a mark on the pipe where you would be able to drill a 3/16 inch hole as close as possible to the cross without touching it. This is the hole through which the first turn of the spiral coil will pass.

Remove the pipe from the cross and make additional marks every 2 cm all the way out to the end (the long way, away from where the cross fits). Use the first pipe as a template and mark the other three pipes the same way. Now drill 3/16 inch holes as marked, all the way through both sides of all four pipes.

Using PVC cement, glue the four pipes into the cross to make the coil form. Be sure to glue the right ends of the pipes, so the innermost hole is close to the cross without being obscured by it. Take care also to keep the holes in line with the plane of the cross, so a coil can be wound, as in the picture.

Use 5 meters of 12 ga. wire for the spiral coil. Any type of wire is suitable electrically. I used wire with a slick insulation for ease of threading through the coil form. Starting from the inside, leave 10 cm of slack for the inner coil connection, and thread the wire through all four innermost holes in the coil form, pulling it tight.

Continue to thread the wire progressively outwards in a spiral shape, pulling it tight as you go. Make sure you always have the 10 cm of slack inside for the connection to the pipe. When done, use a cable tie to keep the wire from slipping back out, as shown. To reduce wind resistance, you may wish to saw off any excess length on the coil form arms. (The ones in the picture have not been trimmed.)

The final step in making the spiral coil is attaching the 3/4 inch male PVC plug to the side of the cross, so the coil can be screwed down onto the copper pipe. To do this, rough up one side of the cross with sandpaper. If you will do most of your communication in the Northern Hemisphere, let the coil run clockwise... (just kidding!). Also rough up the flat end of the 3/4 inch PVC male plug. Slather on some PVC cement and hold the plug in place until the glue has a chance to set up. Here is a [close-up picture of the joint](#) between the plug and the cross. It may not look strong but PVC cement forms a strong chemical bond. Do not screw the plug into anything until the glue dries overnight.

Now that you have the coil, you must make the pipe portion of the antenna top. This is easy. Sweat a 3/4 inch female adapter onto each end of a 20cm length of 3/4 inch copper pipe. (If you wish to experiment with tuning, you might want to leave one end unsweated (as shown) and/or start with a longer length of pipe. If you wish only to duplicate my results, don't worry about getting the length perfect -- the tuning is very forgiving, in terms of the length of the vertical element.)

As you can see in [this detailed photo](#), I sweated on mounting brackets near the top end to make available four holes at right angles. Once I'm sure I won't want to take down the antenna for a while, I might use those to attach ropes to steady the top of the antenna. For now, though, I prefer not to use the ropes. It is so much easier to take the antenna down without them. Even if you don't plan to use ropes, you must sweat on something that will allow you to solder the spiral coil wire without damaging the PVC plug on the coil form with excessive heat.

To complete the spiral top assembly, screw the coil form into the pipe, with the mounting brackets (or other soldering post) toward the top. Cut off any excess length and solder the inner end of the spiral coil to the bracket or post. Be careful not to damage the PVC plug with heat.

When completed, your spiral top should look a lot like the one in the photo.



Making the main vertical element

Click the picture above for a more detailed view.

The vertical element is chiefly a 10 foot length of one inch copper pipe. The only critical thing about this assembly is that it is necessary to slide a guy ring over one end of the pipe *before* sweating the top end

on.

Choose an end of the pipe to be the bottom and sweat on a one inch male adapter. Also sweat a piece of wire (I used 14 ga. solid but it is not critical) to the bottom end for attachment to the feed line. In this [detailed photo](#), the wire can be seen as a ring just above the male adapter sweat joint, and also where it attaches to the coax.

About six feet from the bottom end, sweat on a ring consisting of a few turns of solid wire. This ring will stop the guy ring from sliding down. (The picture at the beginning of this section shows this ring stopper in detail.)

Slide a guy ring onto the top of the pipe, making sure it is the right way up (skirts point down). Be sure the ring you just soldered onto the pipe holds the guy ring in place. Also make sure the guy ring can turn freely while straining against the stop. This will make it much easier to install and take down the antenna.

Finally, sweat a 3/4 inch male adapter (for 1 inch pipe) to the top end of the pipe. This will attach to the spiral top when the antenna is assembled.



Preparing the base

Click the picture above for a more detailed view.

The base of the antenna consists of a galvanized pipe which acts as a mast and a PVC "barrel" which secures the antenna to the mast mechanically without connecting it electrically.

To make the PVC barrel, simply cement two one inch PVC female adapters to a short length of one inch PVC. The pipe should be just long enough that the two adapters touch or nearly touch.

Before screwing the barrel onto the mast, it will be necessary to slide a guy ring on. If you use the recommended radio shack guy ring and one inch galvanized pipe, the guy ring won't *quite* fit over the end. Use a grinding or reaming tool (I used a dremel) to increase the size of the hole in the guy ring. It is not necessary to make it fit over the entire pipe. It only needs to be able to slide down over the threads enough that the barrel can screw on securely.

Slide the guy ring over the top of the mast, using the included bracket if necessary to keep it from sliding down. Screw the PVC barrel onto the top.

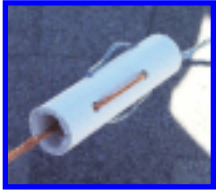

Making the radials and guys

Click the picture above for a more detailed view.

Both the radials and guys require insulators. If you have 24 good quality egg insulators, by all means use them. I had trouble finding any and decided to use PVC to make low-cost insulators. As you can see from the picture, I drilled four 3/16 inch holes through a 4-inch piece of half inch PVC, with interlaced pairs of holes at right angles. (No way that language would be clear without a picture!) The advantage to this approach is that the wires are actually linked, so when the PVC inevitably rots from the sun's UV rays, the structure is still mechanically secure. That's the theory, anyway. Note the way each wire is threaded into one end, out and over the side, then through to the other side, over and back in, then out the end again.

Once you have made or otherwise obtained 24 insulators, you are ready to prepare the radials and guys. We'll start with the radials.

To make the radials, cut four lengths of 12 ga. copper wire slightly longer than 3.5 meters, such that the radial will be 3.5 meters long once the ends are wrapped around the guy ring at the base and the insulator at the other end. Attach an insulator to one end of each radial. Solder the wire as shown for extra strength.

Attach the non-insulator end of each radial to the guy ring at the top of the mast (just below the PVC barrel). Do this by making a loop and soldering it as shown in this [detailed photo](#). Solder a loose ring of copper wire to each loop, all the way around the guy ring, to ensure that the radials are electrically connected at all times. Coil up and tie the radials neatly. They are now part of the base, ready to install on the roof.

To make each guy, use steel guy wire to construct a string of five insulators spaced one meter apart, for a total length of 4 meters per guy string. (Longer, electrically continuous guy segments can mess up the antenna's performance.) Make 4 guys, using a total of 20 insulators.

Use the shortest length of steel guy wire possible to attach the insulator on one end of each guy string to the guy ring that slides freely on the main vertical element. This [detailed photo](#) shows how. Neatly coil up and tie the guy strings. These are now part of the vertical element, ready to install.



Installing the base

Click the picture above for a more detailed view.

Find a suitable location at the apex of your roof, surveying where the radials and guy wires will go. Avoid power lines for safety. Once you find a good spot, screw the roof mount down securely with lag screws. Use roof tar to weatherproof the mount as shown before the next rain or snow.

Install hooks for the guy wires and radials at four locations such that the radials will be spaced as evenly as possible (90 degrees apart), and such that the radials can be fully extended (3.5 meters from top of base) and not yet reach the hooks.

Place the mast near the mounting point. If an assistant is available, the mast can be held in mounting position. Run the radials out toward the hooks (they shouldn't reach yet) and secure them to the hooks with a length of steel guy wire extending from the insulator to the hook. [This picture](#) shows what the insulator looks like with one copper wire and one steel wire. Leave enough slack that the radials can be under tension, fully extended, once the mast is raised. Without an assistant, getting these lengths close enough to let go is cumbersome. Be patient and don't risk letting the mast get out of your control.

Once the mast is basically in place, adjust the tension at the hooks until the radials are fairly taut and the mast is vertical and feels secure. Tighten the mounting screws and lock nuts in the apex mount to complete the installation of the base.



Adjusting the guys

When the guys are adjusted to the perfect length, one person over five feet tall can easily raise and lower the antenna without help. It is necessary only to push the antenna up into the guys, then screw it down into the PVC barrel. Until the guys are perfectly adjusted, though, it can be dangerous to attempt to raise the antenna fully without assistance. Proceed cautiously and have patience, and make all guy length adjustments without the spiral top installed.

Attach fairly long pieces of steel guy wire to the end of each guy string, and secure them to the hooks. It

should be possible to raise the vertical element near to its mounting position without straining the guys. Now slowly and patiently, progressively shorten the guys at the hooks until they are just long enough to permit the vertical element to be raised into position and screwed into the base. (Having an assistant is extremely helpful.)



Completing the installation

Now that the guys are adjusted, raising the antenna is very easy. Screw the spiral top onto the vertical element, then hoist the antenna into place and screw it into the base. Connect coax as shown in [this picture](#), without soldering yet, and run it to an analyzer, noise bridge, or transmitter with SWR meter.

The only critical adjustment is the length of the coil, which mainly affects performance on the 20 meter band. 5 meters is a bit too long for the spiral coil wire, so you should find that the antenna is initially resonant somewhat below 14.2 MHz. Carefully lower the antenna repeatedly, shortening the spiral coil to bring the antenna into resonance near 14.2 MHz. I ended up with a 4.75m coil length. If you were able to duplicate my design parameters, you should find the performance on the 15m and 10m band to be as shown in the SWR charts.



About [N5IZU](#)

I got my first ham ticket in 1978 at the age of 12, and I've been building the occasional antenna ever since. Most of them haven't worked, but every once in a while, something interesting happens. When I read about Petlowany's spirals I just had to know more about them. I had no idea what would actually be possible.

I still feel I know so little. I've put this project on the web in the hopes that someone will write me a breathless email one day, explaining, "No, -DT, you've got it all wrong! A little change here and there and you can have *five* bands!" Even more exciting would be to learn exactly how and why it works the way it does.

In the meantime, it is nice to just enjoy it for a while. Recently I've been content to just haunt the bands, chasing whatever DX gets snared in the *burner*.



Go to [-DeeT's Hacks Page](#).

Back

[David B. Thomas \(dt@dt.prohosting.com\)](mailto:dt@dt.prohosting.com)

Pfeiffer Quads

KQ6RH

(C) 1998, 1999, 2000

Ray Jurgens

(Up-Dated 3/07/2000)

Pfeiffer Quads:

The Pfeiffer Quad was described in QST and has the desirable feature that it is smaller than a standard cubic quad but does not compromise performance very much. The Pfeiffer design is rather difficult to construct because of the complicated linear loading networks required. However, these complicated structures are unnecessary and do not add much, if anything, to the performance. The Pfeiffer quad has linear loading stubs at each corner that are pulled into the center toward the hub forming a Maltese Cross. These could just as well be replaced with inductors or transmission line stubs. In fact, the losses on 450 Ohm ladder line are small to insignificant, so Pfeiffer's complicated stub assembly can be replaced with simple transmission line stubs with no loss of performance. The only complication is in the electromagnetic modeling; here the density of pulses must be very high to accurately handle the closely spaced wires. The stubs can be stretched along the spreaders and attached to the antenna wires at each of the tips. In this case, 8' spreaders are convenient, so all that is required is to find the proper length of the $\frac{1}{4}$ wave shorted stubs that act as inductors to bring the loop into resonance. These stubs can be made slightly longer for the reflector and shorter for the director if one is used. Placing the 450-Ohm ladder line along the spreader slightly lowers its impedance and lengthens its electrical length by the same proportion. The 8' spreaders can be used to cover 20, 17, and 15 meters. In the 15m case, the stubs are only a few inches long and for 20 meters they are about $\frac{3}{4}$ of the length of the spreader. If terminal strips are mounted at the end of each tip, the stubs can be changed easily to accommodate various bands. Some experimentation may be required to get the length of the stubs set, but once set, assembly is very quick for this quad. Our [Products Page](#) lists the our design document which gives the a complete set of graphs and design data as well as full construction details for our modified Pfeiffer Quad.

The Pfeiffer Quad is normally operated in the X configuration. The impedance of this antenna will be lower than for a full size quad, and some matching network may be required. The

version presented in QST used a gamma match on one of the stubs to drive the loop. For example, at 20 m, the stubs must to be about 74" long, and the driving impedance of a single loop is about 47 Ohms. Thus, a single loop is a good match to 50-Ohm line. The addition of the parasitic elements further lowers the impedance, and depending on the spacing of the loops, the impedance could drop to 25 Ohms. For further details on the original Pfeiffer Quad, check the following reference:

Andy Pfeiffer, K1KLO, "The Pfeiffer Quad Antenna System," QST, March 1994, pp. 28-31.

[Return to Main Menu](#)

Phased Arrays of Short Vertical Antennas

It is possible to devise an array of two or more vertical antennas to provide useful gain and directivity over a single vertical element, but proper design and adjustment may be a more complicated matter than one might think because gain depends on such factors as spacing between elements, phase difference, etc., and these will change from one band to the next. About the most one can hope to do is to work out a compromise design that will be truly effective on two adjacent bands.

Probably the simplest system would involve two vertical antennas spaced from $1/2$ to $3/4$ wavelengths apart at the highest frequency of operation and fed with equal in-phase currents. Such an array would be bi-directional and provide up to four decibels of "broadside" gain. At half the design frequency the broadside gain would be less than two decibels. Thus, an array of the two elements for 40 meters (spacing between elements approximately 35 ft.) would provide a fair amount of gain on that band and perhaps a few decibels less on 80 meters. The same array could no doubt be operated on the higher-frequency bands, but the directivity pattern (if any) would change considerably, for the great spacing (in terms of wavelength) would cause the production of "end-fire" as well as broadside radiation.

In the case of close-spaced elements ($1/8$ to $1/4$ wave) it is possible to produce a unidirectional end fire pattern by feeding the two elements with a phase difference of 90 degrees by means of an electrical $1/4$ wavelength "delay" line. This arrangement produces a rather broad single lobe (cardioid pattern) in the direction of the element with the lagging current, and very good front-to-back radiation are possible with such an array. However, both the radiation resistance and the feedpoint impedance will be much lower than for a single vertical element, making the system more critical with respect to operating bandwidth and impedance matching, especially if each element is physically shorter than $1/4$ wavelength at the operating frequency and if the spacing between elements is less than $1/4$ wavelength. Close-spaced out-of-phase short elements should have the best possible radial system under each element so that the earth loss resistance doesn't account for the major part of the overall feedpoint impedance. If this precaution isn't observed the earth loss may wipe out all or most of the theoretical gain of the array.

Still another problem with close-spaced arrays using physically short elements is that the power-handling capability may be less than for a single element because the mutual impedance between the elements will raise overall circuit Q while reducing the radiation resistance of the array.

As with the relatively wide-spaced in-phase arrays, the close-spaced out-of-phase types may be operated on other bands where the spacing and phase difference will not be optimum and where the directive pattern can be expected to change from band to band.

In general, the Butternut HF6V-X and HF2V will be under less of a disadvantage in phased arrays than conventional multi-trap designs that use a progressively smaller portion of the available radiator at 7 MHz and above, but the problems of devising an effective array on more than one band will remain the same. Wide-spaced in-phase arrays are generally better behaved than the close-spaced out-of-phase types and show higher values of radiation resistance. This makes the ground/radial situation somewhat less critical, but more real estate is required for effective broadside arrays, especially on 80 and 160 meters.

For further information on vertical arrays one should consult a recent edition of the ARRL Antenna Book.

Hawaii Ham Radio Information Pages



- [HF Operation in Hawaii](#)
- [Topband Operation from KH6](#)
- [A Polar Projection Map from Hawaii](#)
- [HI-QRP, QRP in Hawaii](#)
- [QCWA Hawaii Chapter \(QCWA-194\)](#)
- [Soil Conductivity in Hawaii](#)
- [VHF Simplex Operation in Hawaii](#)
- [WWVH in Hawaii](#)
- **Important Ham-Related Designations for Hawaii and the Pacific:**
 - [Grid Squares in Hawaii](#)
 - [Counties in Hawaii](#)
 - [CQ Numbers and DXCC Designations](#)
 - [IOTA Numbers in the Pacific](#)





[Antenna Information](#)

Rabbit Ears have been used to solve the limited space antenna problem of how to operate HF from a condo in Urban Honolulu. After much testing, this design has been working:

[The Upright V Dipole for Limited Space](#)

Near Vertical Incidence Antennas in Hawaii have been the source of much speculation. The NVI mode is ideal for HF communications statewide, critical to emergency communications where VHF simplex cannot span the distances required. Here is a modeling study of optimized NVI dipoles:

[The 40 Meter NVI Dipole](#)

A comparison of **Portable Antenna types** using EZnec modeling. Including dipoles, optimized 1/4 wave vertical systems, fan dipoles and inverted V's:

[Common Portable Antennas Compared](#)

The "**Stake Stick**" is a multi-band antenna for the higher bands designed for portable use such as backpacking. It uses full size, tunable elements on 20, 17,15 and 10 meters with six meter operation available as a 3/4 wave antenna:

[The Stake Stick Vertical](#)

Vertical antennas are great, as are end fed wires. Easy to put up and locate in restricted spaces. But they often put heavy demands on **ground systems and radials**. Here is some of the "bad news" about

grounds, ground enhancements, what does and does not work:

[Radial Ground Systems](#)

An entirely new area, Ham antennas for WiFi, extending operation of 802.11b wireless network access to allow high speed digital radio experiments cheaply, even up to and including adding amplifiers which for licensed Ham Radio operators is legal under part 97. When it exceeds part 15 specifications, it should be properly called HSMM or High Speed MultiMedia hamming:

[Hinternet Antennas for WiFi and HSMM](#)

For portable operations, many people are attracted to lofting field day type antennas with **gas filled balloons**. Here are details on what it takes to get such a project off the ground:

[Balloon Lift With Lighter Than Air Gases](#)

Almost as popular as balloons for portable antenna experiments are **kites**. Here are a few kite related notes:

[Kites Suitable for Lifting](#)

The SLOPO is the result of much research with EZnec looking for a reasonable portable antenna that had as little to carry as possible and yet had significant performance. It was hard to beat a simple dipole and come up with a single pole system that had merit, but the SLOPO, the combination of the sloper dipole with a reflecting support pole, making a sort of beam, shows promise:

[The SLOPO portable antenna system](#)

The EDZ extended double zepp antenna is a classic. It may have fallen from favor due to its ugly feed point impedance. It is highly reactive at about 120 ohms resistive. But a tuner like a Johnson Matchbox

and parallel line should make short work of that problem, and provide a multiband antenna of merit. It also makes a good gain producing antenna for portable use at the higher bands such as this example at 15 meters:

[The 15 Meter Extended Double Zepp](#)

Here are lots of numbers for **wire antennas** on various bands from 160 to 6 meters to help you decide how big a given antenna design will be, what might fit in your "*personal antenna farm*", and what style of wire antenna might be appropriate for your QTH:

[HF Wire Antenna Sizes](#)



[General Ham Radio Information](#)

Information on the new **online Ham Radio Licensing** system, how to use it, the new forms and the FCC websites to download the new online forms. This is how all Ham licensing issues will be addressed in the future:

[The FCC Universal Licensing System](#)

Camping and Ham Radio, especially QRP or low power, go together well, but here are some things to consider to make life in da tent easier and more fun when the two activities are combined:

[Radioactive Camping Tips](#)

Batteries are a great emergency power source, but their ratings and chemistry, especially rechargeable ones, is often *Witchcraft*. Here is some information to help sort them out:

[Using Batteries](#)

Jumpstart Powerpacks have appeared that are compact units with a sealed lead acid battery and integral charger. This is a report on one such example and conversion to a highly portable QRP/HT power source:

[MightyMite Conversion](#)

If a repeater fails, a Net Control Station will have to establish a **net protocol** on a VHF simplex frequency. Here are some guidelines for both Net Control Stations and Net Participants:

[Guidelines for Simplex VHF Net Operations](#)

One of the hardest parts of traffic handling on a net is figuring out how to **count the message**. The message count is an important "checksum" to verify that the entire message was received. Getting it wrong can cause lots of confusion:

[Guidelines for Word Counting Message Traffic](#)

This site contains the latest information from the **repeater frequency** coordination database for Hawaii:

[Hawaii Repeaters](#)

Salt air and Aluminum or Iron do not mix well. Here is a guide to **goo and gunk** designed to make aluminum connections stay connected and fight the rapid conversion of your new beam to white powder and all steel fasteners to red stains:

["Conductive" Greases](#)

In May 1998 there was a major series of solar events. The result was one of the most intense **HF blackouts and Geomagnetic storms** in a decade. One of the QRP-L list regulars unloaded a massive broadside of information in the form of annotations of solar reports, descriptions, explanations, etc. that constitutes one of the best learning experiences available on solar phenomenon and HF propagation. Suck in your gut, brace yourself and read:

[Seven \[SOLAR\] Days in May](#)

This is an great discussion of working Sporadic E skip on 10 meters from a member of the QRP-L Email list:

[Sporadic E on 10 Meters](#)

To help sort out any **RFI** problems you might be having, here is a list of the frequencies of TV channels, both over the air and cable:

[Cable, TV, and FM Channel Frequencies](#)



[Other Ham Radio Specialty Sites](#)

This is a listing of selected web sites for **Other Hawaii/World/Mainland Ham Clubs of merit**:

[Other Ham Club Web Pages](#)

You may find the following Ham radio related web sites useful, they include some very nice **Ham utilities**, some **Callsign lookup** locations, **propagation** related sites:

[Other Ham Radio Information Pages](#)

Here are some major **mail order** Ham radio stores, **manufactures** of Ham equipment, and some selected special sites. Most of these we have some personal experience with:

[Ham Equipment Suppliers/Manufacturers](#)

These pages are **local Hawaii weather** information pages:

[Honolulu NWS and Central Pacific Hurricane Center](#)

[University of Hawaii Meteorology](#)

06/02

HFpack. The HF Portable Group. Calling Frequency 18157.5kHz USB or 18158kHz CW



Over 4000 members

What HF frequencies are open now?

- [Hourly Frequency Maps for Band Openings](#)

These maps are from actual hourly ionosphere soundings.

- [HFpack Frequency Chart 2004c](#)

Use this chart for QSOs with other HF portable operators.

[HFpack](#) is an international resource for portable High Frequency communications.

HFpack provides an information exchange about transceivers, antennas, systems, packs, propagation, new developments and techniques in HF portable operation. The HFpack egroup and on-the-air schedules are active with amateur radio around the world.

HFpack membership is free and open to all radio operators.

HF [Join HFpack](#)
Free

HF [Read HFpack egroup](#)

HF [News](#)

HF [Features](#)

HF [On Air Schedule](#)

HF [HFpack Pedestrian Antenna Shootout Reports](#)

HF [Main Page](#)

HF [Site Map](#)

HF [HFpack Hall of Fame](#)

HF [Read HFpack E-Group](#)

HF [On-The-Air Schedule](#)

HF [Fotos of the Week](#)

HF [Transceivers](#)

HF [Antennas](#)

HF [Packs](#)

HF [Power Sources](#)

HF [Bicycle and HPM](#)

HF [HFpackers Showcase](#)

HF [Database](#)

HF [Join](#)

HF [HFpack E-Group](#)

HF [HFpacking Stuff](#)

Our Motto: Don't Just Listen, Call CQ HFpack!

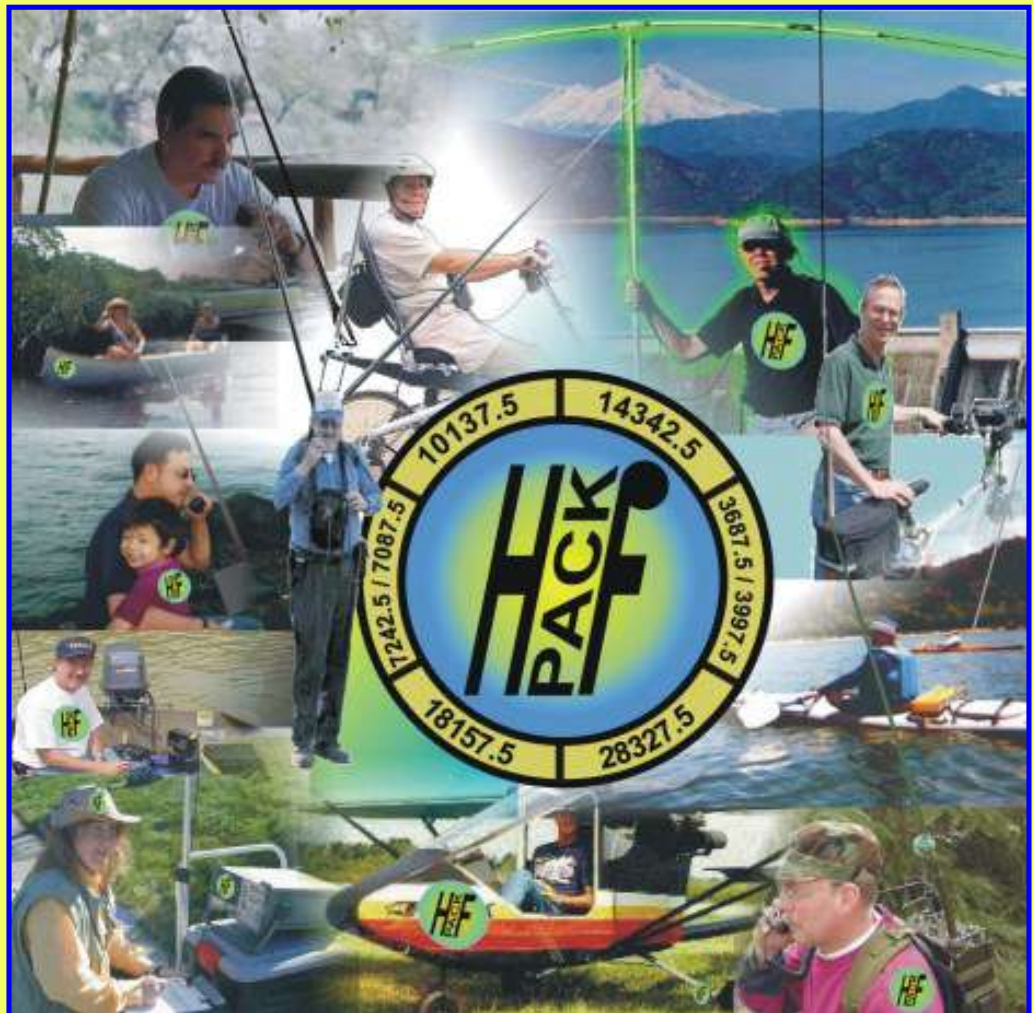

HF [Links](#)

HF [FAQ](#)

Be a part of the exciting HF portable group.
[Join](#) HFpack on the air and on the internet.

HFpack News

[HFpack Frequency Chart 2004c released](#)

[Click here for listing](#)

About HFpack

HFpack is the result of a new type of group developed on-the-air and over the internet. The HFpack e-group is a spam-free moderated discussion group, primarily utilized by amateur radio operators who are interested in HF portable communications and equipment. Subscription and "membership" in the HFpack e-group is free. It is currently active using the Yahoo groups server system, where messages can be read and posted via the web, direct email, or email daily digest modes. Participants in the HFpack e-group observe friendly cooperation and good netiquette. HFpack also maintains [HFpack Hall of Fame](#), the amateur radio Pedestrian Mobile and Human Powered Mobile world record database.

[OA9 / KQ6XA Expedition Peru](#)

2004

[HF Portable 02 July - 25 August](#)

[In addition to the regular daily HFpack schedule at 1630z and 2230z on 18157.5kHz, the expedition will operate on the following schedule:](#)

| Time UTC | Meter Band | Frequency kHz | Schedule |
|----------|------------|-------------------------|-----------------|
| 00:30z | 17m | 18157.5 USB or 18158 CW | Daily |
| 01:00z | 40m | 7087.5 LSB or 7087 CW | Daily |
| 00:45z | 15m | 21437.5 USB or 21438 CW | As needed |
| 03:50z | 30m | 10117.5 CW | As needed |
| xx:xx | 17m | 18095 CW | QSY Freq for CW |

The Cave Expedition Peru 2004 will operate on HF using a 20W transmitter and battery power charged by solar. Radio operators around the world are invited to QSO with OA9/KQ6XA. Please call at the above scheduled times and



[Cave Expedition Peru 2004](#)

HFpack Founder
Bonnie KQ6XA

HFpack egroup Moderators
Bonnie KQ6XA
Bob AB7ST
Virgil K5OOR
Ken N0VZ
Budd W3FF

HFpack Steering Committee
Bob AB7ST
Virgil K5OOR
Ken N0VZ
Budd W3FF
Tom G0SBW
Kenji JA1NGA
Sasi 9V1SM
Brad VK2QQ
Bill KR8L
Tom KC5UN
Joe W5SAN
Ken WB6MLC
Mark KI0PF
Sharyl W3VET
Bonnie KQ6XA
Randy K3QO
Bill K6ACJ
John K6ERO
Bill KM4P
Jerry WA2OMU
Jay N1RWY

frequencies on SSB or CW. Listen for response in CW or SSB. QSL via eQSL.

HFpack.com Features

HF [HFpack Pedestrian Shootout Reports 2001, 2002](#)

HFpack is dedicated to furthering the state of the art for HF Portable. The HFpack Pedestrian Shootouts 2001 and 2002 measured pedestrian antenna systems to a fraction of a decibel, and the reports are presented as a service to radio operators around the world... ([more info](#))

HF [HFprojects! HFpacker Amp, Z-Match Tuner,](#)

[Portable Battery Pack - Charger](#)

Virgil K5OOR, an active HFpacker, has developed a new homebrew 35W SSB/CW pedestrian/portable amplifier, Z-Match tuner, and battery pack in small packages. Hundreds of radio operators are now building them together and buying parts together, thereby reducing the cost. A group build is now open. Visit the HFprojects.com website for more information about HF Projects.

HFpack On The Air

HFpack Daily Global Calling:
18157.5 kHz USB or 18158 CW
Day time calling 30 minutes past each hour

HFpack On The Air Saturday and Sunday Schedule

| UTC Time | Freq kHz | Region |
|----------|-------------------------|--------|
| 16:30z | 18157.5 USB or 18158 CW | Global |
| 22:30z | 18157.5 USB or 18158 CW | Global |
| 01:45z | 5371.5 USB | USA |
| 09:15z | 3587.5 LSB | VK/ZL |
| 18:40z | 7087.5 LSB | Europe |

Don't just listen... Call CQ HFpack!

HFpack's special On-The-Air egroup is called [HFnow](#). It is the place to post skeds, operating times and frequencies.

Hourly Propagation Maps

**Optimum Frequency Maps Centered on World Cities
Based Upon Hourly Ionosphere Soundings**

Updated at 40 minutes past the hour; please reload your browser.

[North America NVIS](#) - [North America Regional](#)

[Europe NVIS](#) - [Europe Regional](#)

[Australia NZ NVIS](#) - [Australia NZ Regional](#)

[Far East Asia NVIS](#) - [Far East Asia Regional](#)

These maps are made from data gathered in real time around the world using HF ionospheric radar systems called ionosondes. Ionosondes bounce HF radio signals off the ionosphere to measure the height of the reflective zones and signal strength vs frequency. The maps are generated using the ionosonde data to make projections based upon a base station working a mobile. To use the maps on this site, locate a map for city near your QTH. Follow the color frequency contours to locate an area you wish to communicate with. For optimum signals, tune your radio to the ham band closest to the MHz of the color range indicated by the map.

Mapping source: Australian Government [IPS](#) Radio and Space Services

**NORTH AMERICA NVIS OPTIMUM FREQUENCIES
for communications within 200 miles**

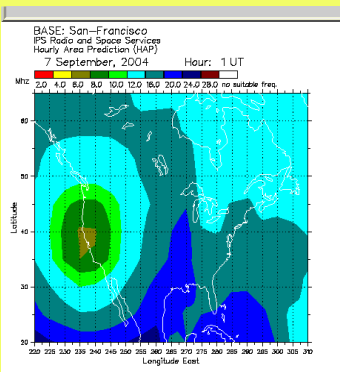

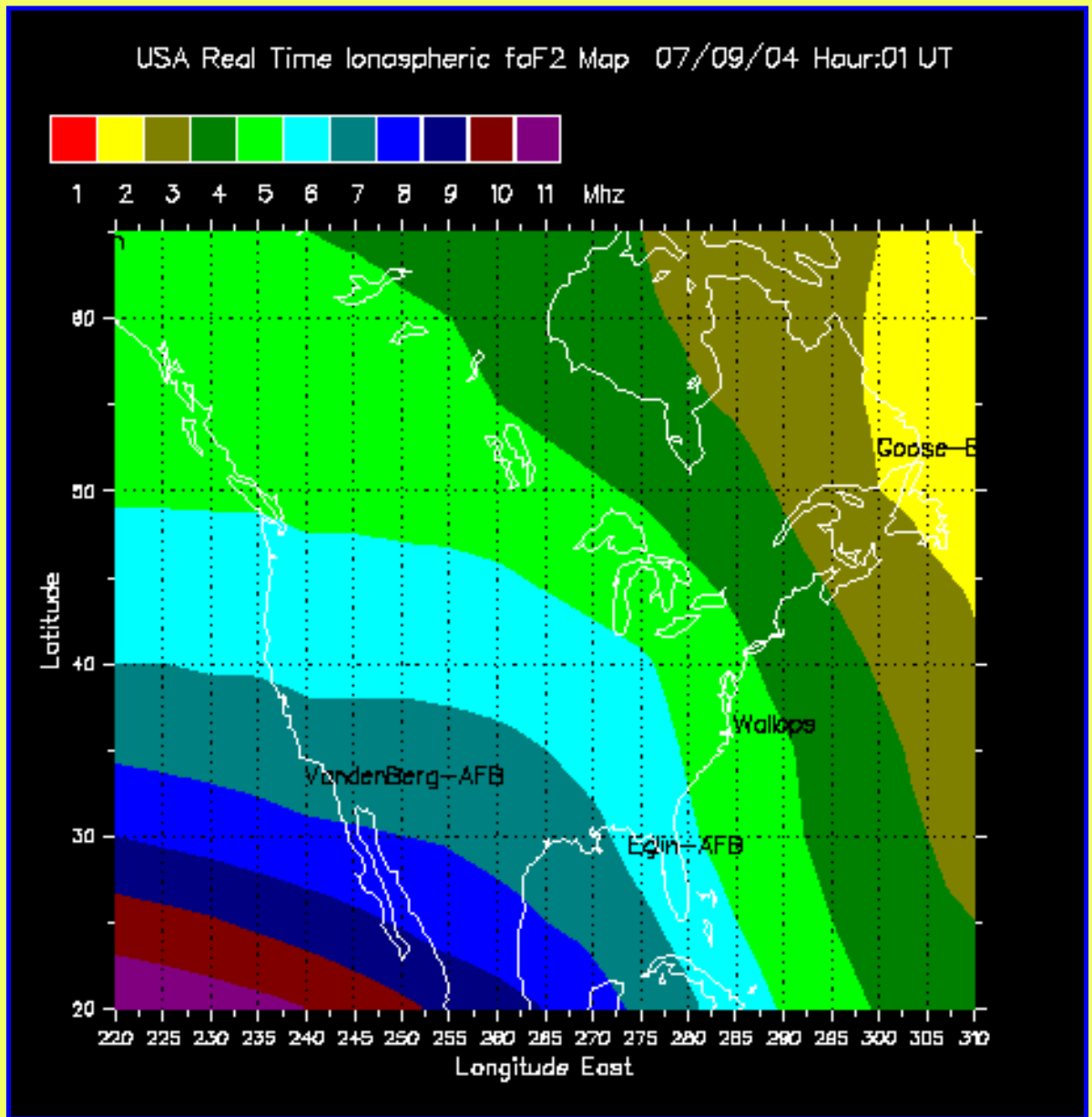

Updated at 40 minutes past the hour; please reload your browser.

EUROPE NVIS OPTIMUM FREQUENCIES for communications within 300 kilometers

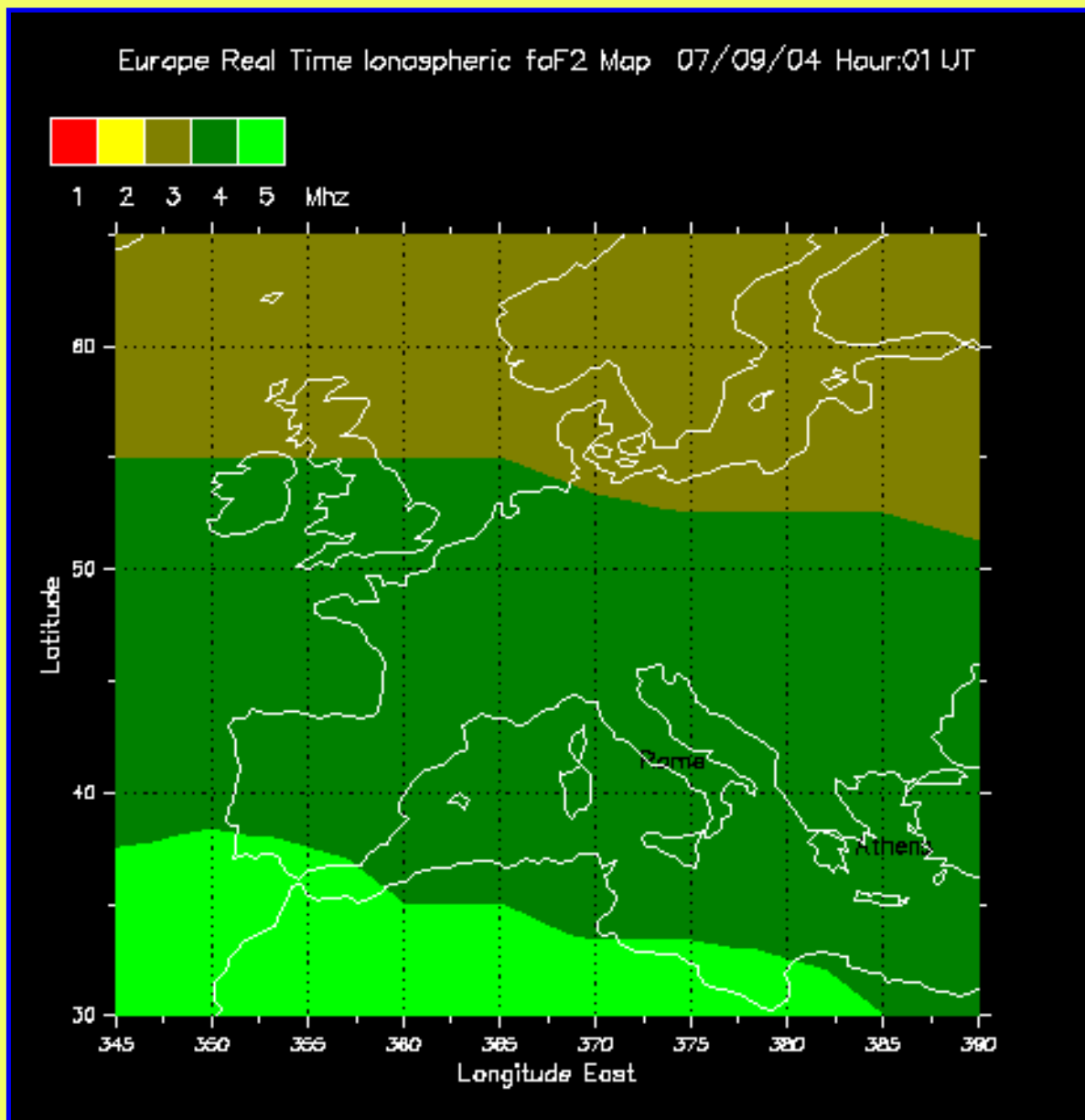

Updated at 40 minutes past the hour; please reload your browser.

**VK/ZL Australia - South Pacific
NVIS OPTIMUM FREQUENCIES
for communications within 300 kilometers**

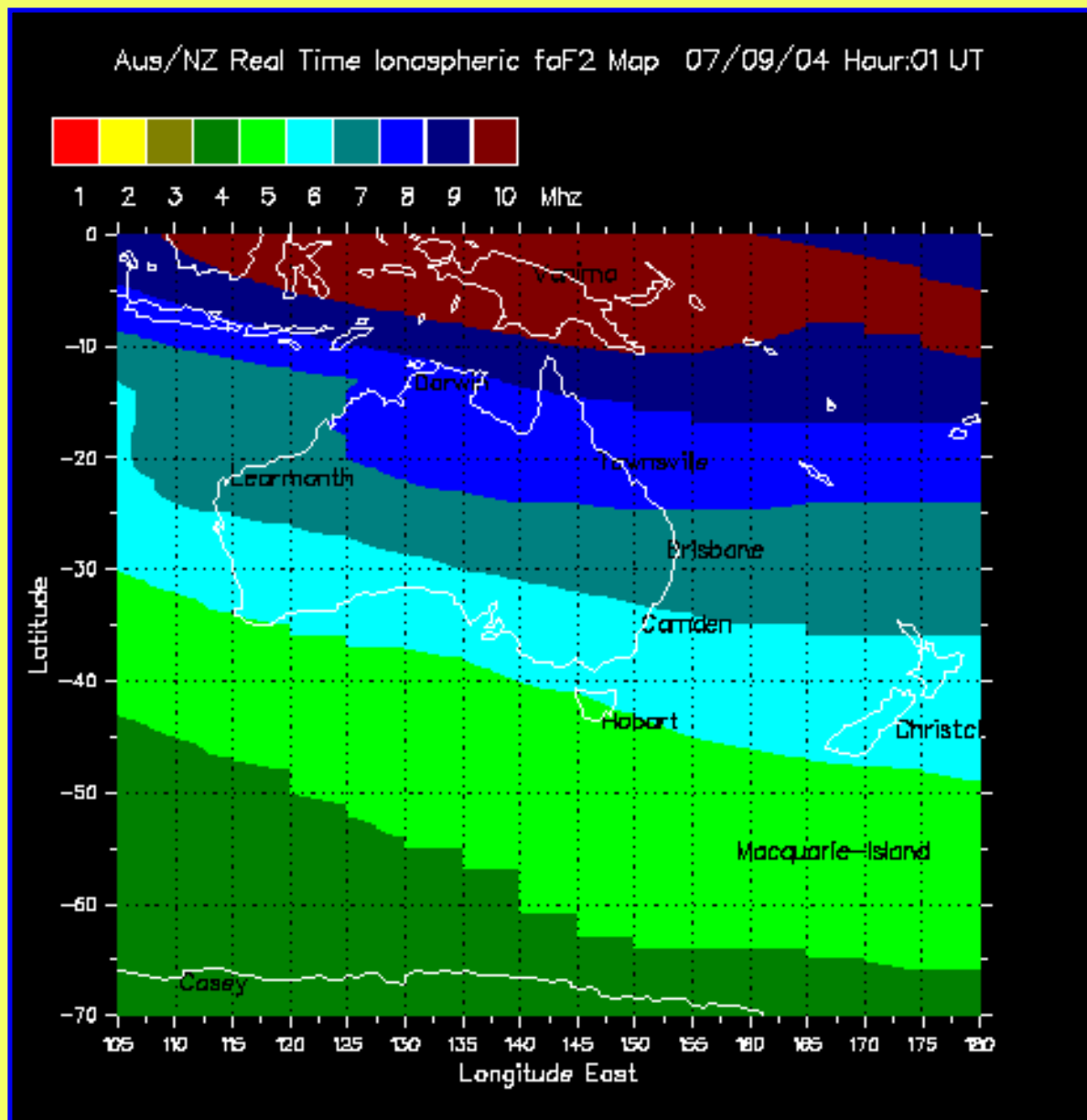

Updated at 40 minutes past the hour; please reload your browser.

Far East Asia NVIS OPTIMUM FREQUENCIES for communications within 300 kilometers

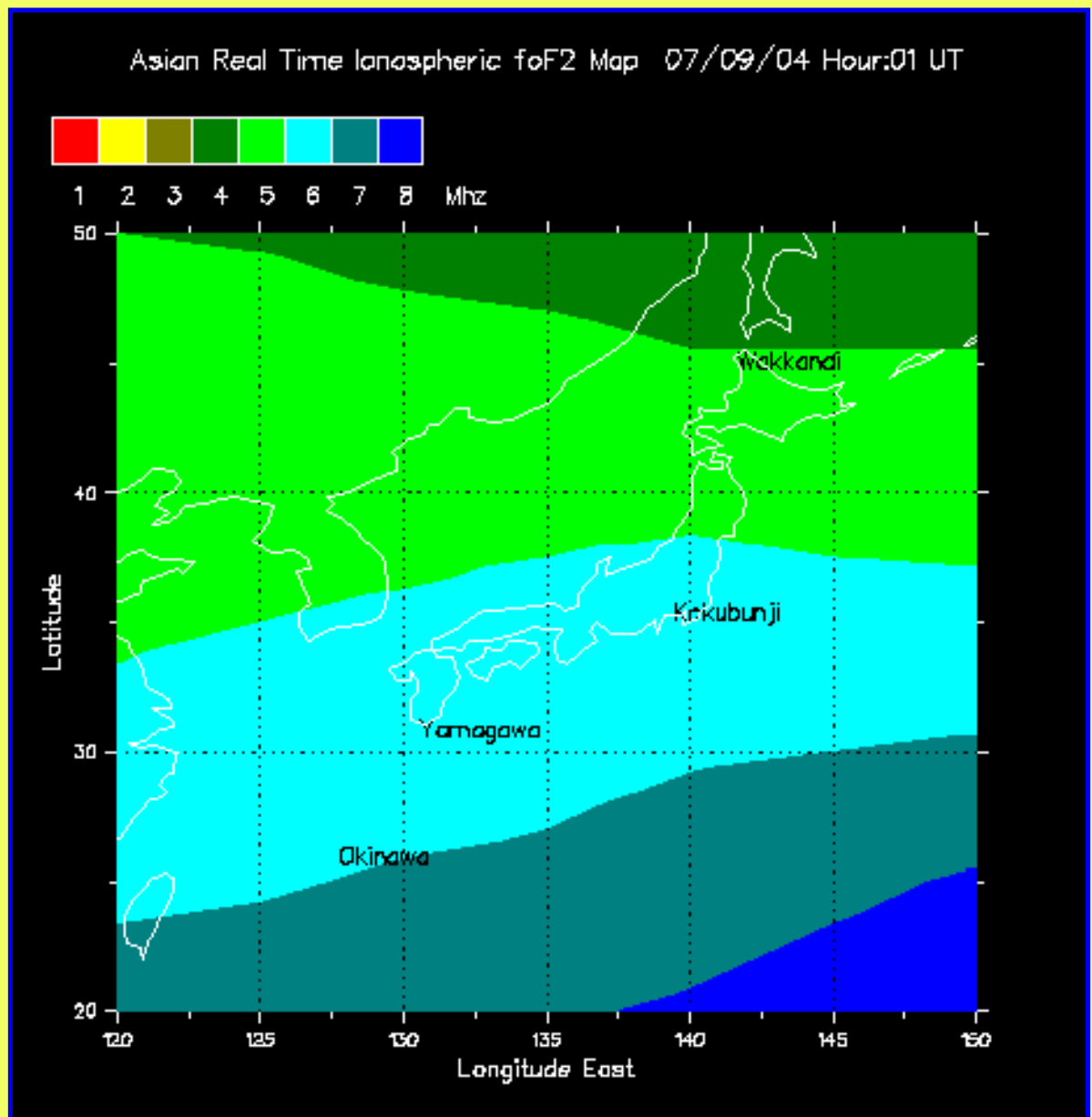

These maps are made from data gathered in real time around the world using HF ionospheric radar systems called ionosondes. Ionosondes bounce HF radio signals off the ionosphere to measure the height of the reflective zones and signal strength vs frequency. The maps are generated using the ionosonde data to make projections based upon a base station working a mobile. To use the maps on this site, locate a map for city near your QTH. Follow the color frequency contours to locate an area you wish to communicate with. For optimum signals, tune your radio to the ham band closest to the MHz of the color range indicated by the map.

Mapping source: Australian Government [IPS](#) Radio and Space Services

Regional Optimum Frequencies

Centered on world cities
click on map to zoom

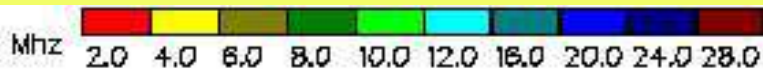

San Francisco

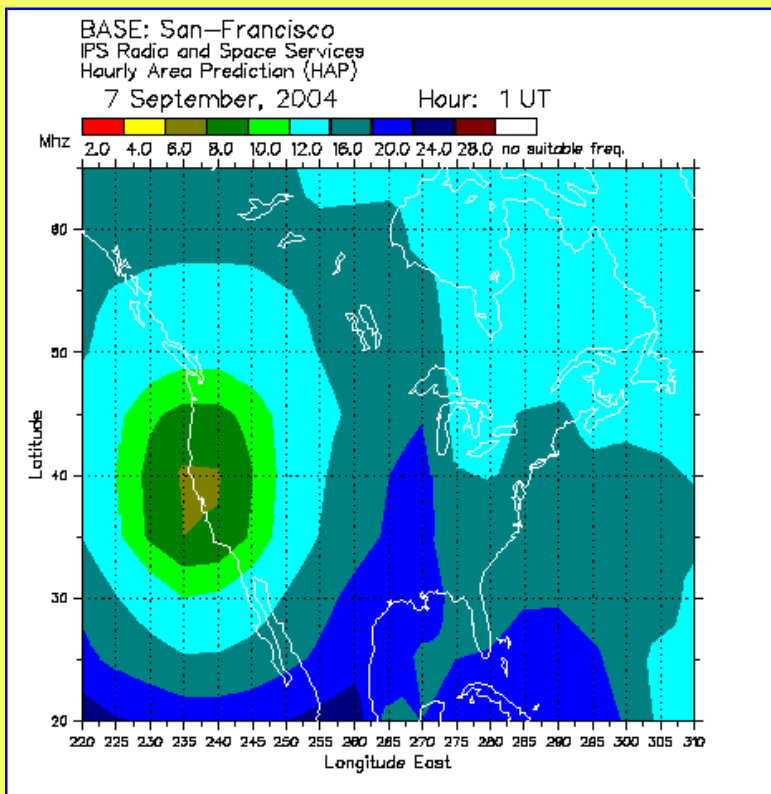

Boulder

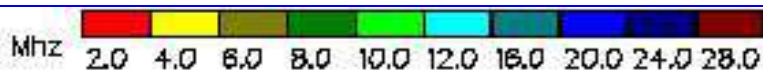
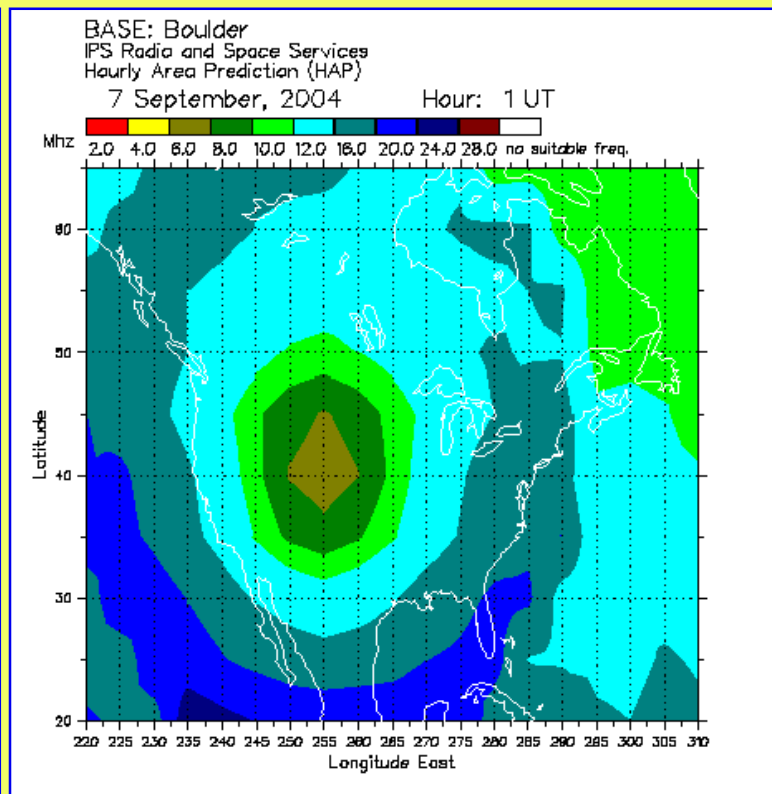

Kansas City

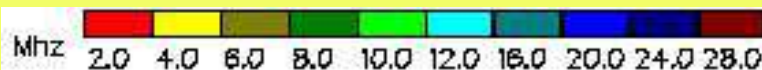

Washington DC

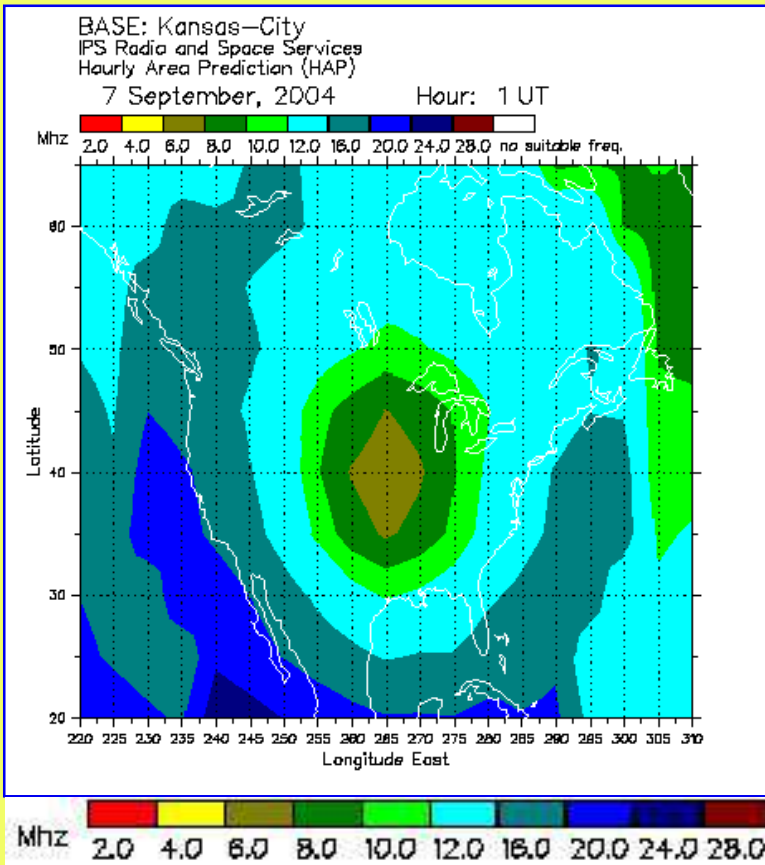

Whitehorse

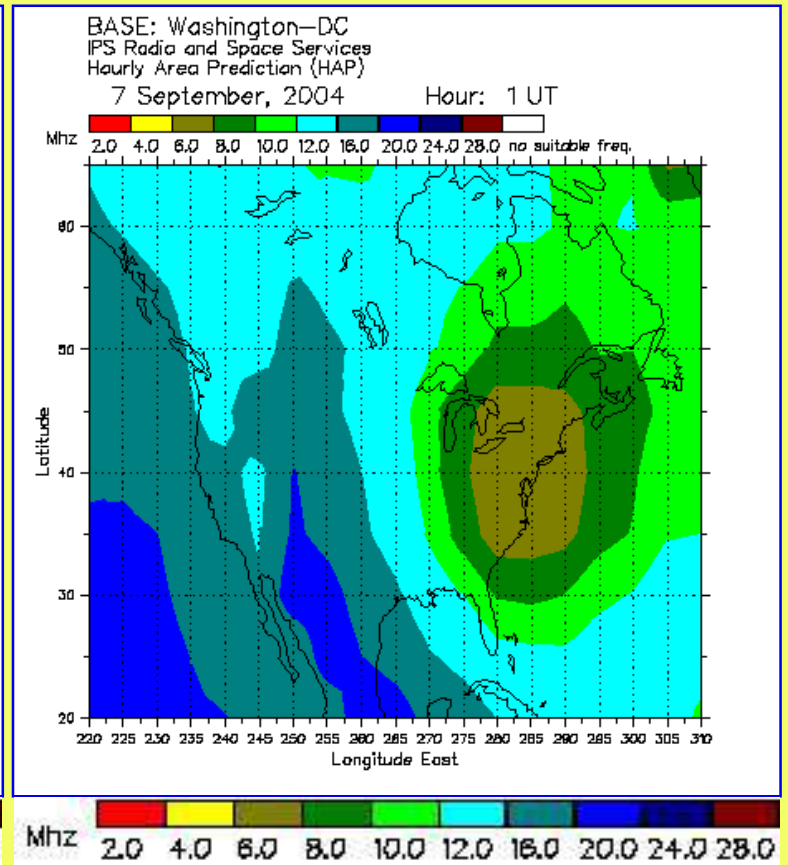

Montreal

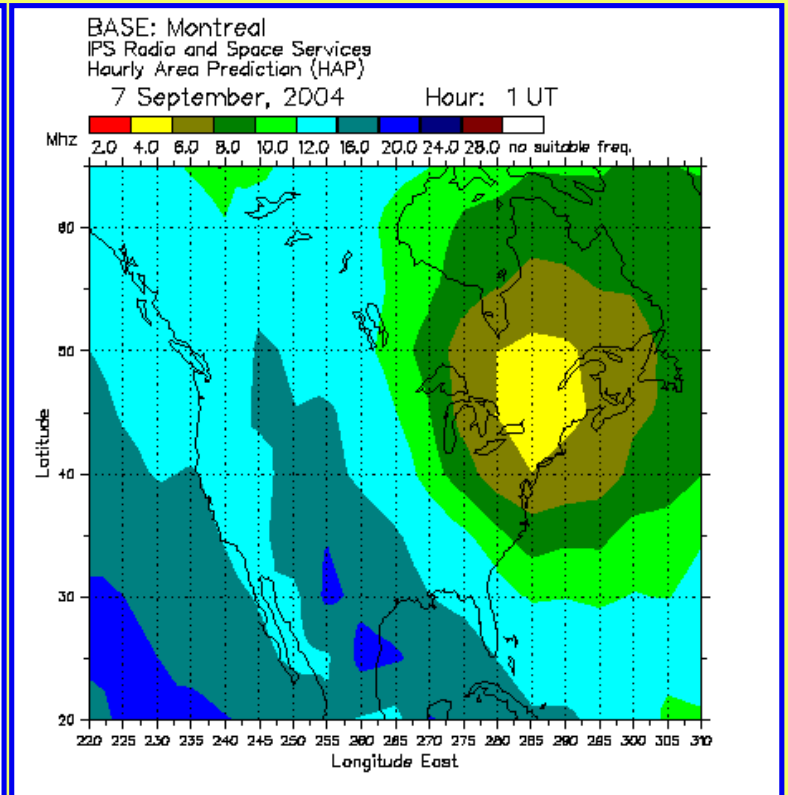
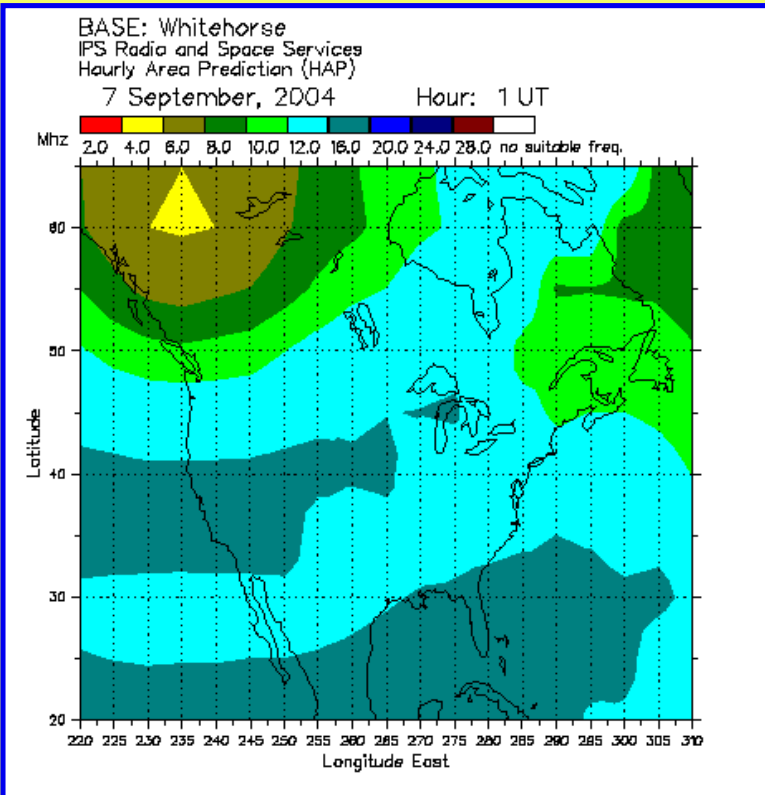



London

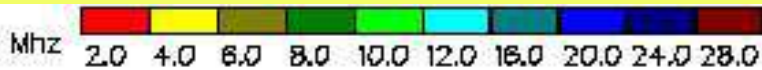
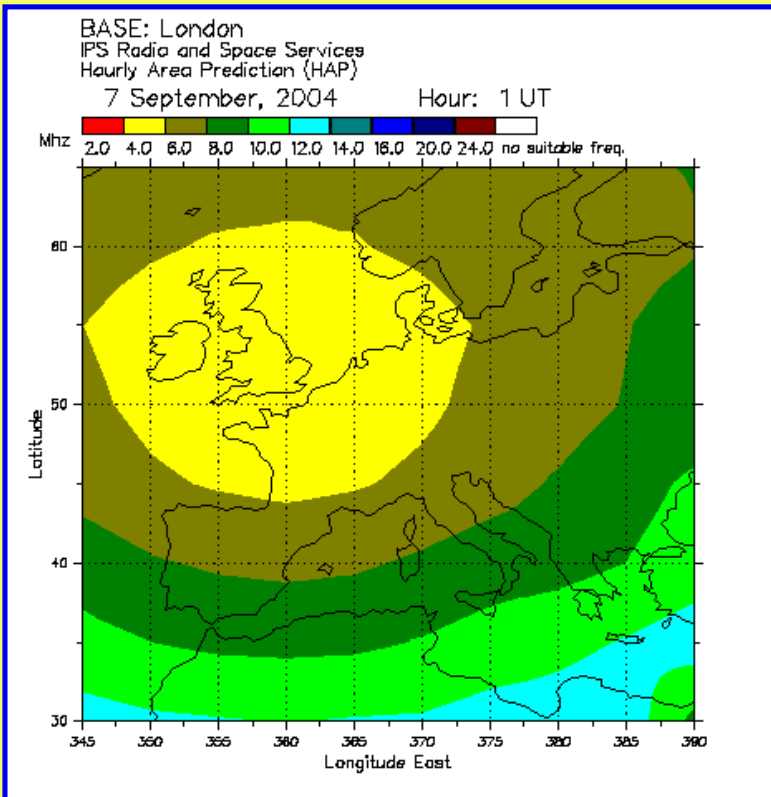

Rome

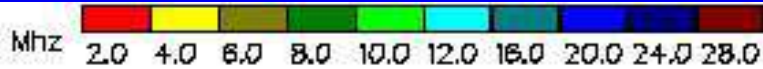
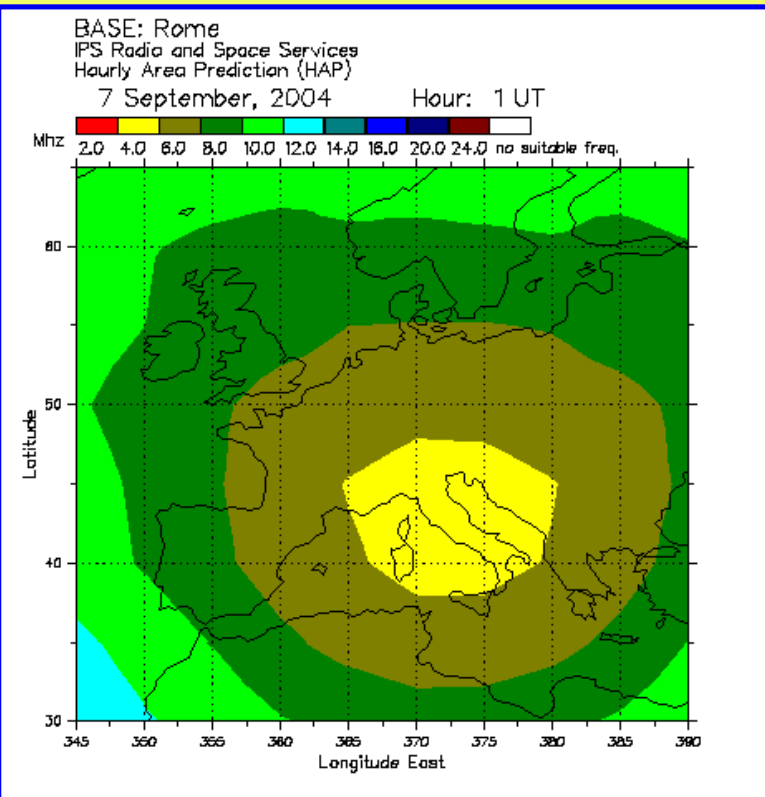

Stockholm

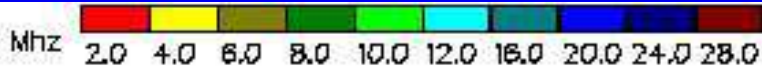
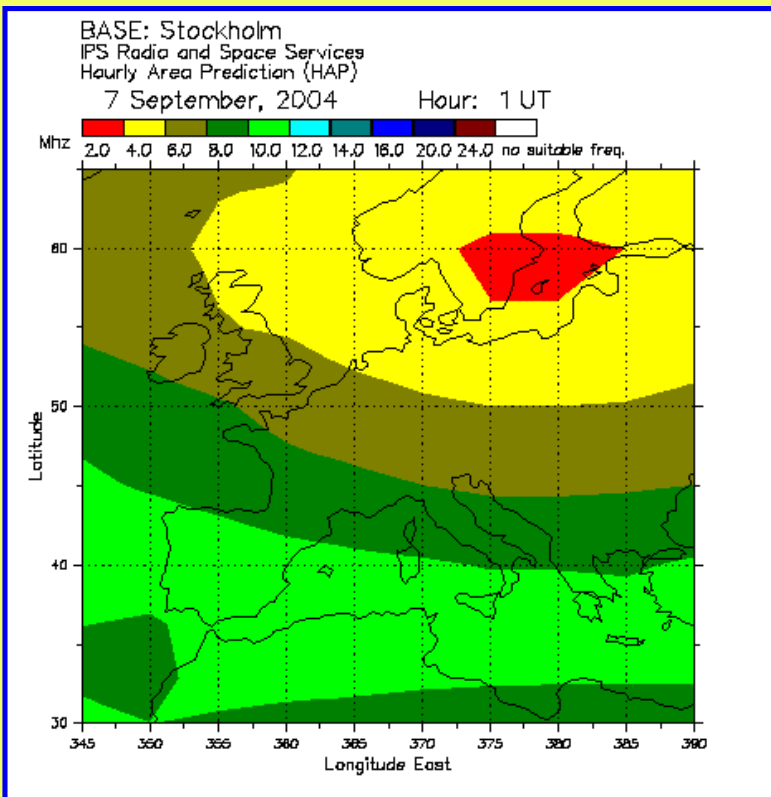

Tokyo

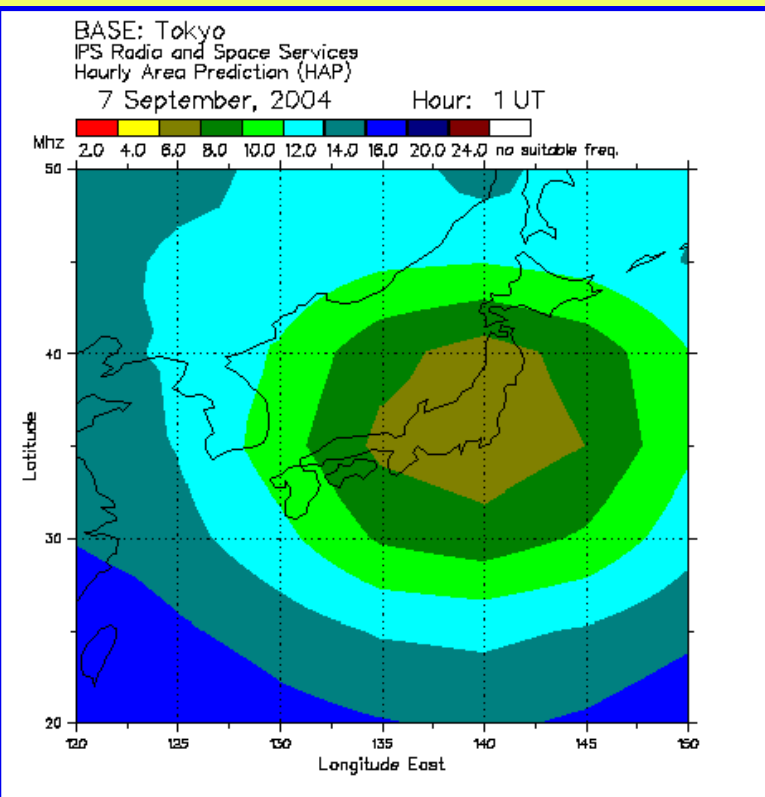

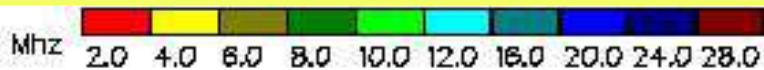

Sydney

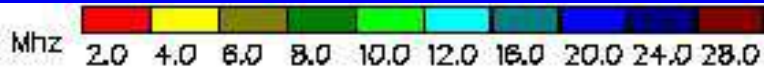
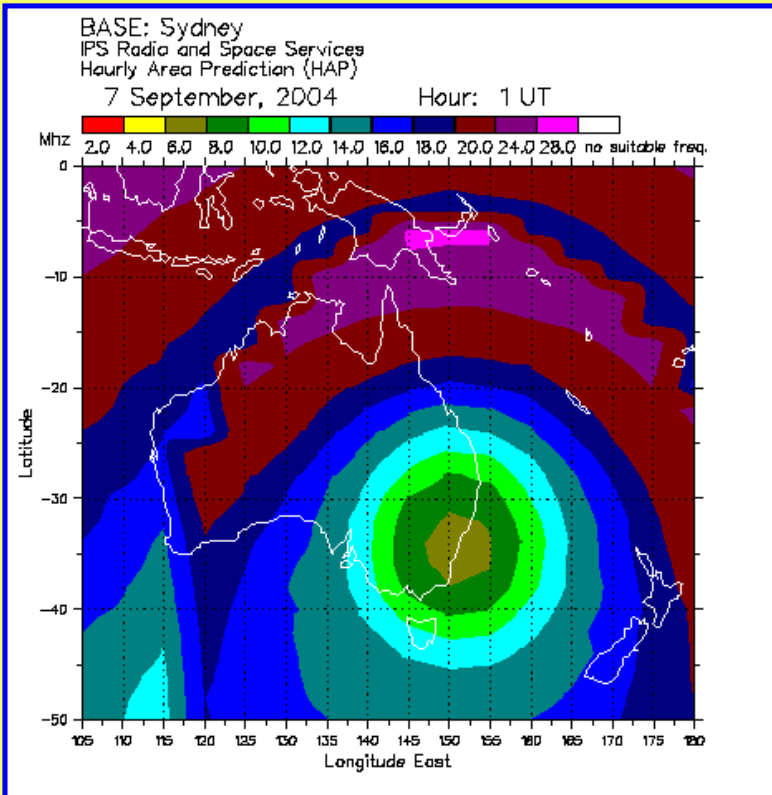

Perth

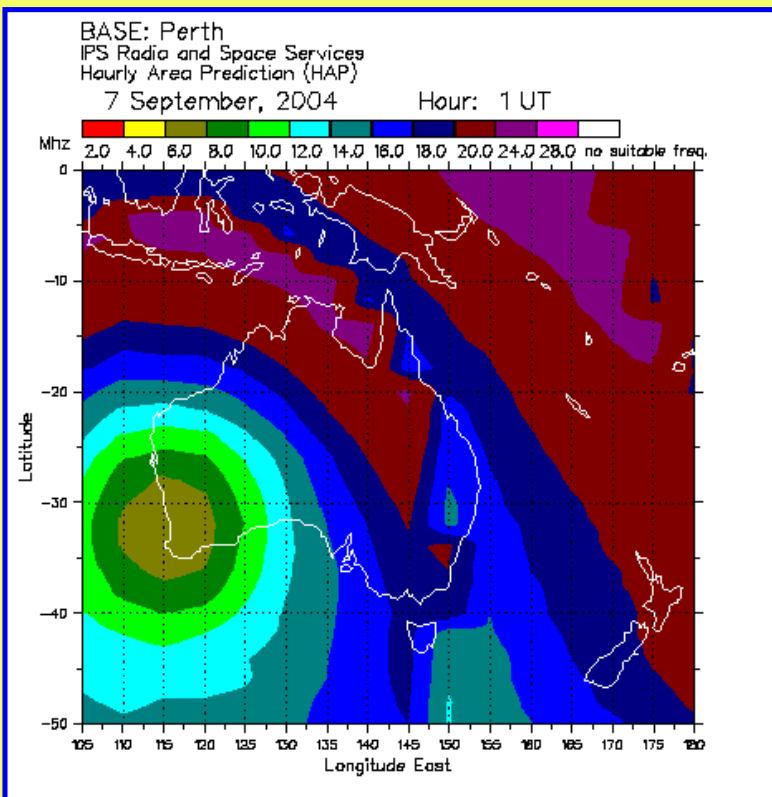

Auckland

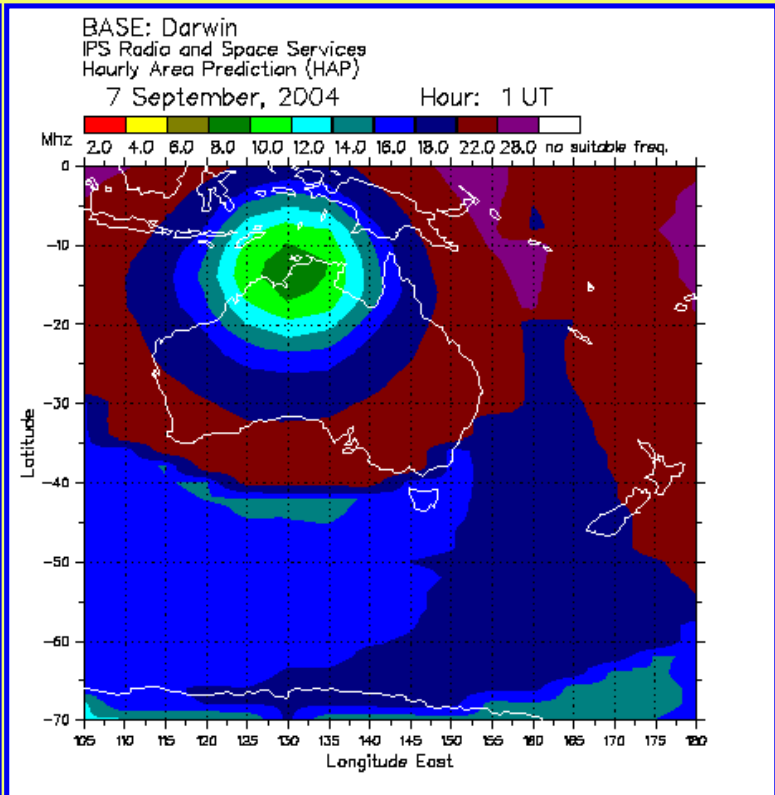

**Ionospheric HF Propagation Map source:
Australian Government [IPS](#) Radio and Space Services**

The members of HFpack wish to express appreciation for the propagation services provided by the Australian Government.

HFpack is all about...

High Frequency Portable transceivers and antennas. HF SSB/CW/Data. Amateur commercial marine. Handhelds backpacks, carry-ons, manpacks. Pedestrian and Human Powered Mobiles. Manual and automatic antenna tuning. Telescopic tape folding and collapsible antennas, dipole, broadband hf vertical antennas. Battery solar crank alternative energy power supplies. Compact lightweight miniature equipment. Handsets headsets microphones earphones keyers. Low power TX/RX techniques. Portable amplifiers. Hiking camping bicycling kayaking and expeditions.



HFpack is all about...

High Frequency Portable transceivers and antennas. HF SSB/CW/Data. Amateur commercial marine. Handhelds backpacks personpacks manpacks. Pedestrian and Human Powered Mobiles. Manual and automatic antenna tuning. Telescopic tape folding and collapsible antennas, dipole, broadband hf vertical antennas. Battery solar crank alternative energy power supplies. Compact lightweight miniature equipment. Handsets headsets microphones earphones keyers. Low power TX/RX techniques. Portable amplifiers. Hiking camping bicycling kayaking and expeditions.

The fine print: ©2001, 2002, 2003, 2004 HFpack. All Rights Reserved.

HFpack, HFpack Hall of Fame, and the HFpack Logo are trademarks of HFpack. Permission is granted for the HFpack Logo to be used for non-commercial purposes only by amateur radio operators who are members in good standing of the HFpack group for their QSL cards and personal websites. The HFpack Logo may be used by non-commercial or commercial websites only for the purpose of hyperlinking to the main page of the HFpack.com website. Capture of the HFpack website or any part of it within the frame of another website is not permitted. Public archiving of the HFpack egroup is forbidden. All photos on the HFpack website are property or copyrighted by HFpack, or when used by permission, are copyright by their respective owners, with all rights reserved.

No part of the HFpack website may be used without written permission.

All links to the HFpack site must be to the HFpack website main page <http://www.hfpack.com>

Some very interesting info about Broadband HF Portable Dipole Antennas at [milisec](http://www.milisec.com) <http://www.milisec.com>

Rhombic Antenna, 30m-6m

[click here to go back to index-page](#)

Rhombics are high gain directive wire antennas. A rhombic is shaped like a diamond, if you're looking down on it. I.e., there are 4 'legs', 2 end 'points', and 2 side 'corners'.

This one was designed for 10 meters and 6 meters, but it's proven useful all the way down to 30 meters. Gain figures are:

| | | |
|-----|------|---------------------------|
| 6m | 11db | about equal to a 7el yagi |
| 10m | 10db | about equal to a 5el yagi |
| 15m | 8db | about equal to a 4el yagi |
| 20m | 6db | about equal to a 3el yagi |
| 30m | 4db | about equal to a 2el yagi |

(gain figures are referenced to a horizontal dipole at the same height)





This particular rhombic is 120' long, 70' on a leg, 25' high, and it's a "terminated" rhombic, which means:

- it is *not* a resonant antenna
- it is *inherently* broadband, 2 octaves or even more
- it does *not* require a tuner...*if* you can match it to the xmitter properly!

Rhombics have a high input impedance of about 600-800 ohms, so it's a non-trivial matter to achieve a match to 50 ohm coax *while still retaining the very broadband nature inherent to the terminated rhombic.*

Matching the Terminated Rhombic:

After much wailing and gnashing of teeth (i.e. experimentation with many different balun transformer designs), I came to the conclusion that the books are right; you just can't get a ferrite balun xformer to work well at both high frequencies *and* high impedance. About 200-300 ohms is the limit for "broadband" work.

This led me to do some research on "tapered lines", the result of which is shown in the pictures here. After several prototypes, I settled on the tapered 2-wire transmission line shown here. I used a modified exponential taper, from 10.00" to .300", over a length of 33', creating a broadband linear transformer from 750 ohms to 200 ohms. The 200 ohm end feeds into a 'normal' 4:1 ferrite balun, which completes the 16:1 ratio required to match to 50 ohm coax.

Results with Tapered Line:

With this setup, I've finally achieved a good SWR over the entire bandwidth of the antenna; less than 1.3:1 from 10-60 Mc. At the important (to me) 15, 10, and 6m bands, the SWR is under 1.2:1. I was never able to get less than 2.5:1 when using two 4:1 baluns in series, so to me this represents a big success.

Power Handling:

Tapered line also has the interesting property, unlike ferrite xformers, of being able to handle lots and lots of power....<g> Now I need to work on a higher power terminator; and then I'll be able to run an amp on the rhombic if I choose. The current terminator is rated 50w continuous; enough for a 100w transceiver, but not for a linear.

Mechanical Design:

The picture above is a shot looking up the feed-end tree; showing the tapered line and the wire-supports. The entire antenna "floats" in its supports. I.e., it is only firmly attached down at the terminator end. At every other corner, the wires slide freely through their "pulleys", which are poly egg-insulators. This design automatically equalizes tension on all legs, and has proven to work very well. The antenna is always flat, and it handles high winds and tree-branch hits with ease.

The rhombic itself is made from #18 enameled copper wire, and the tapered-line is made from #18 stranded tinned-copper PVC insulated wire.

The 1-gallon jugs are the counterweights used to tension the antenna. The amount of water was adjusted to produce the correct tension in the wire.

It came as an unpleasant surprise to me that it's very difficult to take good pictures of thin wires against the sky and trees! <grin> In any case, below is another shot of the tapered line (red vertical wires). You can see some of the "spreaders", which were cut from IC-tubes.

The extra ropes in the picture are the halyards for the ends of the 80m and 40m dipoles, which also use this tree for support.





I'm going to try re-shooting these pictures when the sky is a 'white' overcast, in hopes that the wires will be more visible. I also hope to get a better focus. Usually this Oly D500-L shoots outstandingly sharp pics. Maybe I was vibrating...<g> Stay tuned...

It took a *lot* of clearing to put up this antenna! Three hundred and fifty feet of this....but hey, we needed the firewood anyway <g>.



[click here to go back to index-page](#)



This page created with Netscape Navigator Gold

[Order this information in Print](#)

[Order this information on CD-ROM](#)

[Download in PDF Format](#)

[Click here to make tpub.com your Home Page](#)

Page Title: Rhombic antennas

[Back](#) | [Up](#) | [Next](#)

[tpub.com Updates](#)



[Back](#)

[Up](#)

[Next](#)

Special Antennas Content Moved RF safety precautions

[[Back](#)] [[Home](#)] [[Up](#)] [[Next](#)]

Web

www.tpub.com

RHOMBIC ANTENNA

The highest development of the long-wire antenna is the RHOMBIC ANTENNA (see figure 4-37). It consists of four conductors joined to form a rhombus, or diamond shape. The antenna is placed end to end and terminated by a noninductive resistor to produce a uni-directional pattern. A rhombic antenna can be made of two obtuse-angle V antennas that are placed side by side, erected in a horizontal plane, and terminated so the antenna is nonresonant and unidirectional.

Figure 4-37. - Basic rhombic antenna.

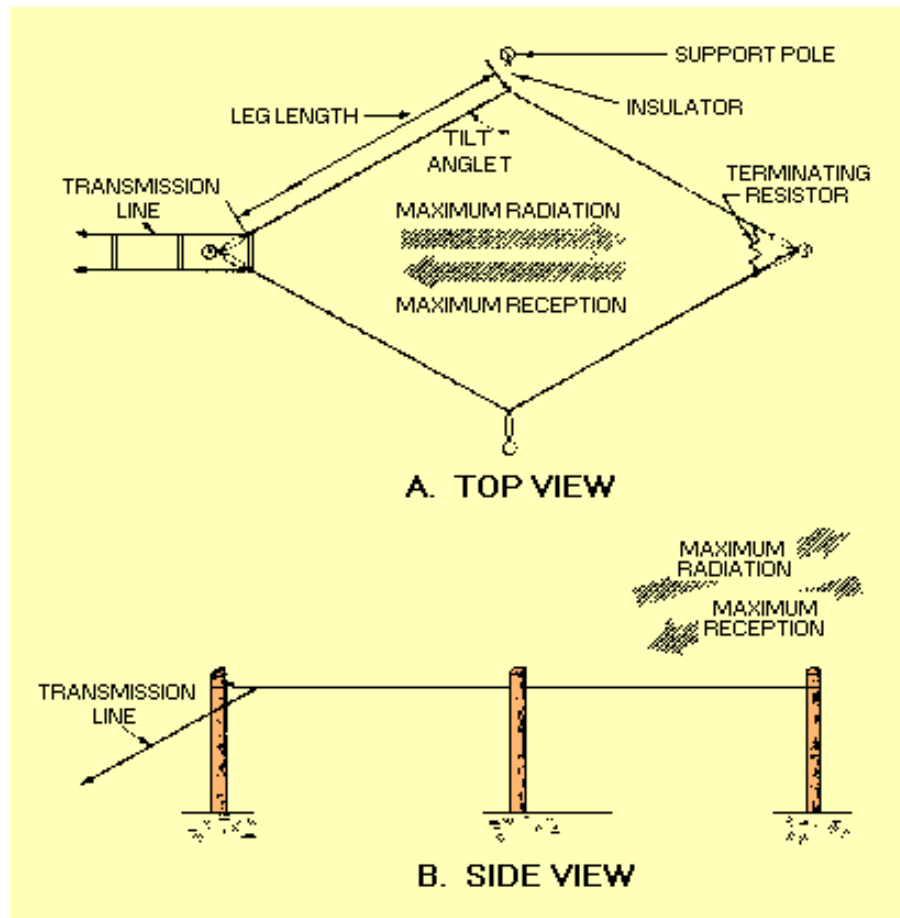

Home

Information Categories

- [Administration](#)
- [Advancement](#)
- [Aerographer](#)
- [Automotive](#)
- [Aviation](#)
- [Combat](#)
- [Construction](#)
- [Diving New](#)
- [Draftsman](#)
- [Engineering](#)
- [Electronics New](#)
- [Food and Cooking New](#)
- [Math](#)
- [Medical](#)
- [Music](#)
- [Nuclear Fundamentals](#)
- [Photography](#)
- [Religion](#)
- [USMC](#)

Products

- [Educational CD-ROM's](#)
- [Printed Manuals](#)
- [Downloadable Books](#)

The rhombic antenna is WIDELY used for long-distance, high-frequency transmission and reception. It is one of the most popular fixed-station antennas because it is very useful in point-to-point communications.

Advantages

The rhombic antenna is useful over a wide frequency range. Although some changes in gain, directivity, and characteristic impedance do occur with a change in operating frequency, these changes are small enough to be neglected.

The rhombic antenna is much easier to construct and maintain than other antennas of comparable gain and directivity. Only four supporting poles of common heights from 15 to 20 meters are needed for the antenna.

The rhombic antenna also has the advantage of being noncritical as far as operation and adjustment are concerned. This is because of the broad frequency characteristics of the antenna.

Still another advantage is that the voltages present on the antenna are much lower than those produced by the same input power on a resonant antenna. This is particularly important when high transmitter powers are used or when high-altitude operation is required.

Disadvantages

The rhombic antenna is not without its disadvantages. The principal one is that a fairly large antenna site is required for its erection. Each leg is made at least 1 or 2 wavelengths long at the lowest operating frequency. When increased gain and directivity are required, legs of from 8 to 12 wavelengths are used. These requirements mean that high-frequency rhombic antennas have wires of several hundred feet in length. Therefore, they are used only when a large plot of land is available.

Another disadvantage is that the horizontal and vertical patterns depend on each other. If a rhombic antenna is made to have a narrow horizontal beam, the beam is also lower in the vertical direction. Therefore, obtaining high vertical-angle radiation is impossible except with a very broad horizontal pattern and low gain. Rhombic antennas are used, however, for long-distance skywave coverage at the high frequencies. Under these conditions low vertical angles of radiation (less than 20 degrees) are desirable. With the rhombic antenna, a considerable amount of the input power is dissipated uselessly in the terminating resistor. However, this resistor is necessary to make the antenna unidirectional. The great gain of the antenna more than makes up for this loss.

Radiation Patterns

Figure 4-38 shows the individual radiation patterns produced by the four legs of the rhombic antenna and the resultant radiation pattern. The principle of operation is the same as for the V and the half-rhombic antennas.

Figure 4-38. - Formation of a rhombic antenna beam.

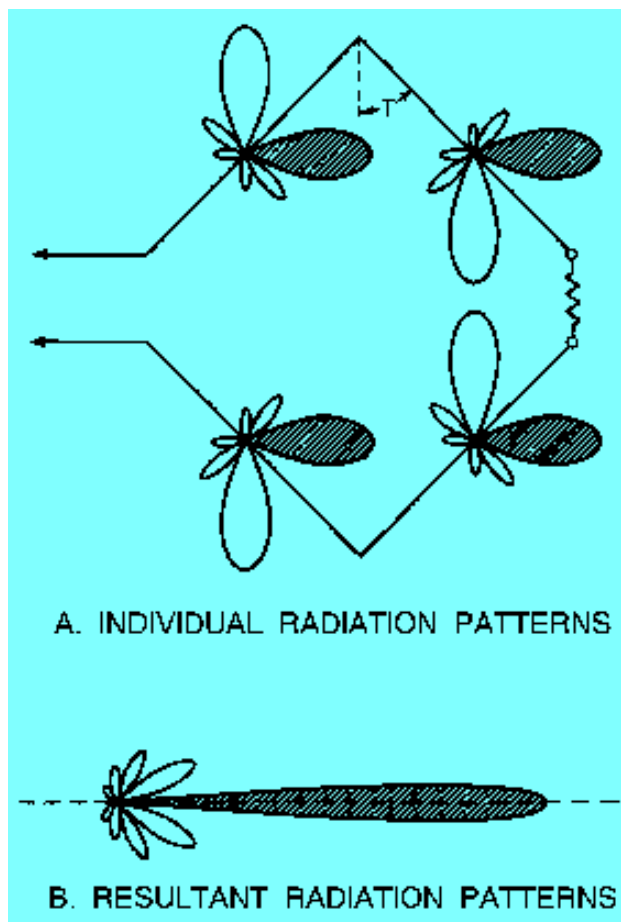

Terminating Resistor

The terminating resistor plays an important part in the operation of the rhombic antenna. Upon it depend the unidirectivity of the antenna and the lack of resonance effects. An antenna should be properly terminated so it will have a constant impedance at its input. Terminating the antenna properly will also allow it to be operated over a wide frequency range without the necessity for changing the coupling adjustments at the transmitter. Discrimination against signals coming from the rear is of great importance for reception. The reduction of back radiation is perhaps of lesser importance for transmission. When an antenna is terminated with resistance, the energy that would be radiated backward is absorbed in the resistor.

Q.47 What is the main disadvantage of the rhombic antenna?

Answer

TURNSTILE ANTENNA

The TURNSTILE ANTENNA is one of the many types that has been developed primarily for omnidirectional vhf communications. The basic turnstile consists of two horizontal half-wave antennas mounted at right angles to each other in the same horizontal plane. When these two antennas are excited with equal currents 90 degrees out of phase, the typical figure-eight patterns of the two antennas merge to produce the nearly circular pattern shown in figure 4-39, view A. Pairs of such antennas are frequently stacked, as shown in figure 4-40. Each pair is called a BAY. In figure 4-40 two bays are used and are spaced $1/2$ wavelength apart, and the corresponding elements are excited in phase. These conditions cause a part of the vertical radiation from each bay to cancel that of the other bay. This results in a decrease in energy radiated at high vertical angles and increases the energy radiated in the horizontal plane. Stacking a number of bays can alter the vertical radiation pattern,

causing a substantial gain in a horizontal direction without altering the overall horizontal directivity pattern. Figure 4-39, view B, compares the circular vertical radiation pattern of a single-bay turnstile with the sharp pattern of a four-bay turnstile array. A three-dimensional radiation pattern of a four-bay turnstile antenna is shown in figure 4-39, view C.

Figure 4-39. - Turnstile antenna radiation pattern.

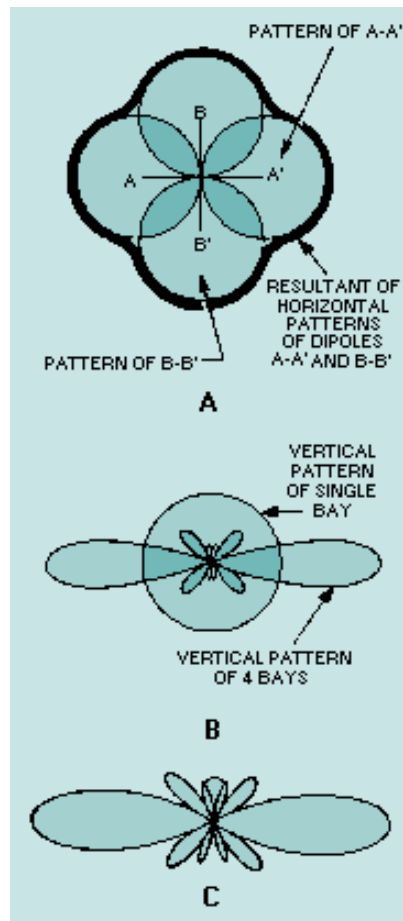
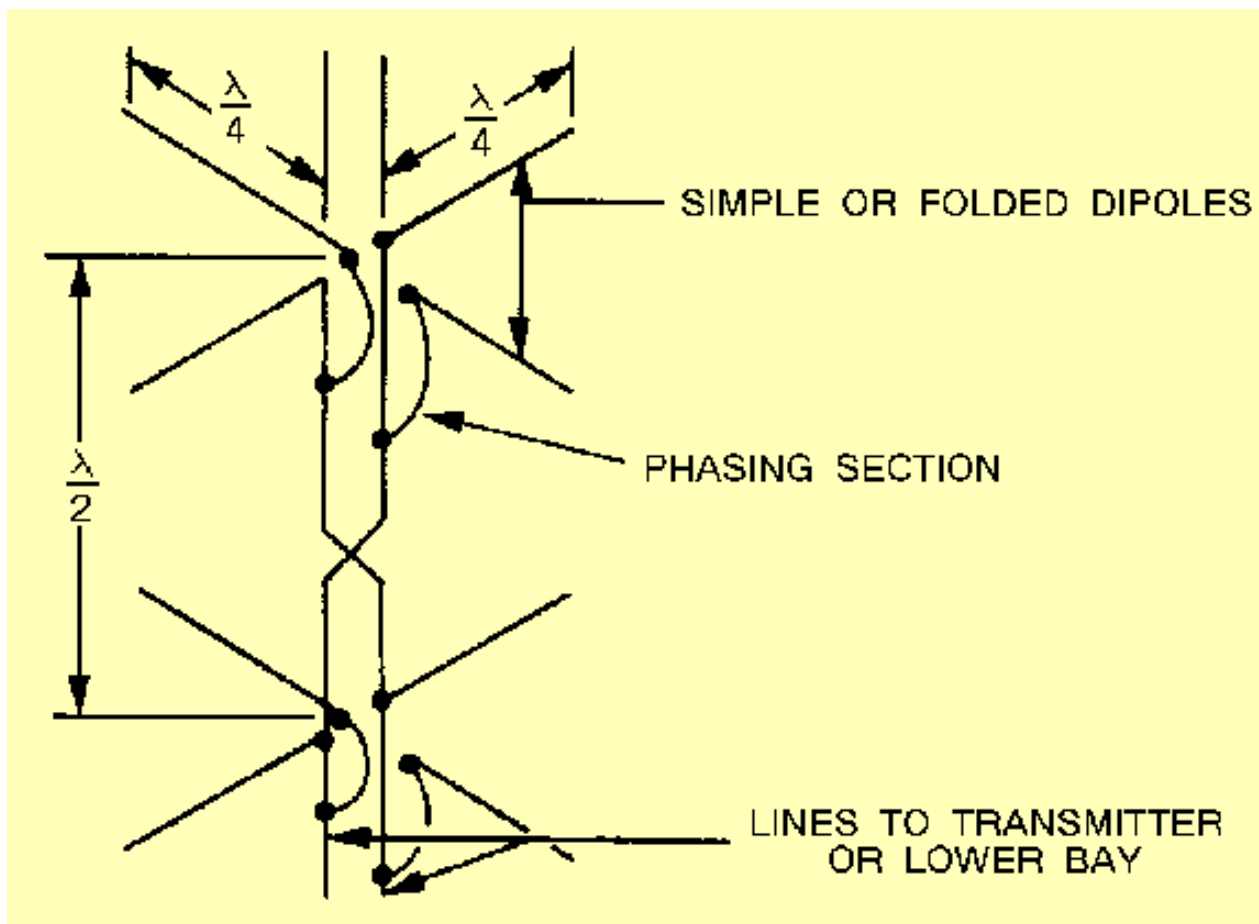

Figure 4-40. - Stacked turnstile antennas.



GROUND-PLANE ANTENNA

A vertical quarter-wave antenna several wavelengths above ground produces a high angle of radiation that is very undesirable at vhf and uhf frequencies. The most common means of producing a low angle of radiation from such an antenna is to work the radiator against a simulated ground called a **GROUND PLANE**. A simulated ground may be made from a large metal sheet or several wires or rods radiating from the base of the radiator. An antenna so constructed is known as a **GROUND-PLANE ANTENNA**. Two ground-plane antennas are shown in figure 4-41, views A and B.

Figure 4-41. - Ground-plane antennas.

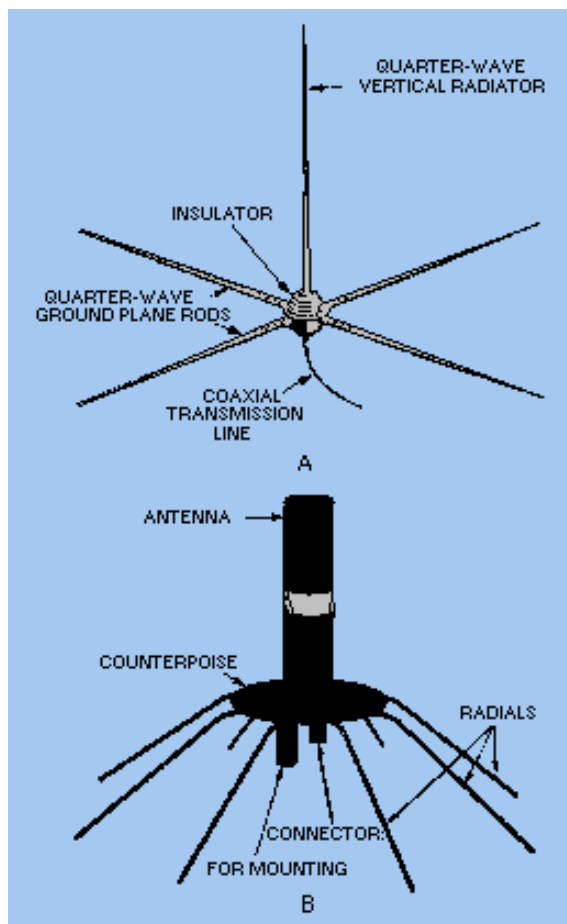

CORNER REFLECTOR

When a unidirectional radiation pattern is desired, it can be obtained by the use of a corner reflector with a half-wave dipole. A CORNER-REFLECTOR ANTENNA is a half-wave radiator with a reflector. The reflector consists of two flat metal surfaces meeting at an angle immediately behind the radiator. In other words, the radiator is set in the plane of a line bisecting the corner angle formed by the reflector sheets. The construction of a corner reflector is shown in figure 4-42. Corner-reflector antennas are mounted with the radiator and the reflector in the horizontal position when horizontal polarization is desired. In such cases the radiation pattern is very narrow in the vertical plane, with maximum signal being radiated in line with the bisector of the corner angle. The directivity in the horizontal plane is approximately the same as for any half-wave radiator having a single-rod type reflector behind it. If the antenna is mounted with the radiator and the corner reflector in the vertical position, as shown in view A, maximum radiation is produced in a very narrow horizontal beam. Radiation in a vertical plane will be the same as for a similar radiator with a single-rod type reflector behind it.

Figure 4-42. - Corner-reflector antennas.

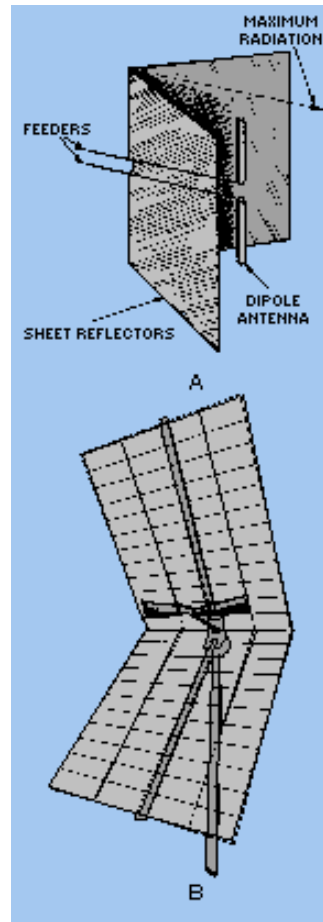

Q48. What is the primary reason for the development of the turnstile antenna?

Answer

[[Back](#)] [[Home](#)] [[Up](#)] [[Next](#)]

[Order this information in Adobe PDF Printable Format](#)

Dinner at Red Lobster on us!
Hungry? Answer a few questions...
...get a **\$50 Restaurant Card**



[Privacy Statement](#) - [Press Release](#) - [Copyright Information](#) - [Contact Us](#) - [Support Integrated Publishing](#)



Rhombic Antenna Home Page

While amateur radio operators today largely employ rotating array antennas such as the Yagi dipole array and the cubical quad antenna, some still use wire antennas, some of which can afford higher gain and lower receive noise characteristics. In fact, the rhombic antenna is usually described as the "King of antennas" because of its very desirable characteristics. The rhombic antenna is basically a diamond-shaped wire curtain that is made of 4 wires, each several wavelengths long connected to form a "diamond" or rhombus shape. The diamond is constructed with the narrowest ends left open for the feed point on one end and a [non-inductive resistive termination](#) on the other. This creates the terminated (also called non-resonant) rhombic which is a unidirectional antenna with broad bandwidth. Non-terminated (also called resonant) rhombics do work but have narrower useful bandwidth and are bidirectional (non-resonant rhombics are fed on one end and the opposite end is left open. In my experience both non-resonant and resonant rhombics work quite well. All wire antennas tend to be less "noisy" on receive and longer antennas like the rhombic are very low noise antennas with the solitary exception of precipitation static (snow and rain add small charges to the curtain and you get very high noise under such conditions). Precipitation static can be minimized by using termination resistors with a grounded center tap (leaks static to ground continuously).

The sides of the rhombic (with the broadest included angle) are constructed of differing dimensions to determine what radiation angle will be obtained. Half of the angle included by the rhombic side is called the "tilt angle" or θ and as the tilt angle is varied, the radiation angle will also vary. There exist various ways to calculate the ideal tilt angle to choose relative to the radiation angle and gain desired for a given rhombic application. Generally the tilt angle is between 65 and 75 degrees. The apex angle is the angle included by the feed point end of the rhombic and is between 30 and 50 degrees and varies with the tilt angle (the sum of half the apex angle and the tilt angle will be 90).

Height is very important for rhombics, as it is for all antennas. Basically, the radiation angle of the main beam of any antenna is related to the height above the ground and the ground characteristics. Generally, for any antenna the following height (in wavelengths)/wave angle (degrees) relationships hold: 0.5/30; 1.0/15; 1.5/8; 2.0/6; 3.0/5. As you can see, to take advantage of the rhombic's extraordinary gain for distant (low angle) communications, you will need to have the antenna at least 1.5 wavelengths high: on 14.0 Mhz, this is around 90 feet, the "usual" height used for rhombic antennas (most rhombics used are in amateur radio usually optimized for 14 Mhz or 20 meter band).

Rhombic antennas are generally fed with open feedlines of around 400 to 600 ohm impedance. This is not critical and any issues related to feeder loss and/or standing wave ratios pales in significance in relationship to this antenna's gain. In the real world things work fine without worry related to feedlines so long as you use a good antenna tuner. Use of baluns is probably unwise as this is likely to limit the useful frequency range of this intrinsically broadband antenna. Many commercial applications of the rhombic use what are called "exponential feeders" with the nominal impedance being 300 ohms at the feeder end and with the paired feedlines gradually spreading to a spacing of around 12 inches at the rhombic feedpoint (a distance calculated to provide the rhombic feedpoint impedance of 600-800 ohms). This exponential feeder provides a smooth transition of impedance and acts as a sort of impedance transformer.



Rhombic Antenna Homepage

In current antenna publications it seems very hard to find anything other than a very abbreviated discussion of rhombics and perhaps some basic design charts and dimensions for a simple rhombic. Little discussion is generally available of the more complex details important to anyone seriously interested in constructing a rhombic antenna. With this in mind, this page has some images of real-world installations and discussion of most of the important practical details you would need to be aware of to construct and maintain a proper rhombic. I am always interested in hearing from anyone with experience with building, maintaining or using rhombics. Images, plan sets and even parts from dismantled rhombics are of interest to me. I will add anything to this page that fits, and then some.

[Click here for an abbreviated discussion of practical rhombic antenna design](#)

[Click here for a detailed text outlining aspects of practical rhombic antenna design \(under construction\)](#)

[Click here to view construction images for the North American Center for Emergency Communications \(NACEC\) rhombic station in Minnesota](#)

[Click here to read about the World War II rhombic station in Scituate Rhode Island \(Chopmist Hill\)](#)

The three images included here are from the WJCR short wave station in Millersville Kentucky and the images were kindly provided courtesy of WJCR. Note the feeders are attached directly to the antenna with little concern for matching. This is not unreasonable as the loss involved is trivial compared to the gain of the antenna (I feed mine directly as well). Also note the use of three wire curtains (slight increase in gain and smoother impedance characteristics across the broad frequency coverage of the rhombic).

The issue of frequency coverage itself is also worth further discussion. While the rhombic is very broad banded, especially the non-resonant terminated antenna, in my hands when optimized for 14Mhz, the antenna is still useful from 10 through 18 Mhz. On the higher bands (18-30 Mhz), the main beam becomes unacceptably "split" with less effective gain in the resulting lobes in the azimuth plane. The antenna is still useful but limited. Perhaps the answer is to build the larger rhombics with smaller antennas that are optimized for the higher frequencies supported at a lower height from the 4 support poles. The rhombics work well when "nested" in this manner and you can conserve space in this way. Additionally, if you get really carried away, you can use the side poles as ends for other rhombics and vica versa. You can even "stack" rhombics running in different directions with clearances of anything greater than 5 feet on HF. Yes, there is a slight degradation but big rhombics are such good antennas that in the real world you shouldn't care. Designs have been built where rhombics are phased together so that in a given direction, one or more rhombics are fed in phase.

Monstrous rhombic arrays have been built in this manner and one can only guess what kind of signals resulted (it's actually rather frightening)!





Harper, of Bell Laboratories, did much of the pioneering work on the rhombic antenna and determined a famous curve that is largely used to design rhombics. Usually some optimization is needed to make sure that the main lobe and the radiation angle coincide. This usually results in a slight loss of gain because of the slightly shorter legs used for a given angle on the sides. Some additional advantage is obtained by having several wires per leg (several curtains), with up to 2 db more gain resulting.



The ability of the rhombic to provide high gain (typically over 9 db for most antennas made and often up into the 20 to 30 db area in arrays of rhombics) , narrow predictable patterns in the azimuth plane, optimized patterns for a given wave angle and physically sturdy construction make the rhombic still the choice antenna for point to point communications operations. Many large rhombic stations existed until recent times and several still are in operation.

Some famous stations included WCC in Chatham Massachusetts, the Rocky Point RCA station and the Palos Verdes Press Wireless Station of the late Don Wallace W6AM's (below). These stations began as commercial stations and had many rhombics, usually with each rhombic covering a given city (again, because you can optimize the wave angle and the azimuth direction is known, you would choose a rhombic with a higher wave angle for cities that are closer and a lower angle for farther destinations). These antennas almost guaranteed an open circuit to the desired locations despite the conditions. Such arrays would usually be fed via open feeders (often 4 wire feed lines to limit loss over the thousands of feet of feeders) and if both directions were desired a switching array would be used to select the direction. Stations would usually have a matrix of open frame RF relays in the shack or in a switch house with a DC switch at the operator's station to select the direction desired. The feeders would arrive in the switch area in layers.

The military has used rhombic antennas for years. In fact, in World War II, the War Department had a rhombic antenna kit (TM11-2611) . This manual was designed to allow the construction of rhombics in the field with indigenous timber for supports and using tables to determine the optimum leg length and tilt angle for communications back to the United States. This design is near optimum for the largest rhombic feasible for practical HF communications.

During World War II not far from my station's location was a classified HF listening station where it is said that rhombics there were used to eavesdrop upon German submarines during the war. This station was said to be involved in the breaking of the German Enigma codes during World War II. This station was located on the top of Chopmist Hill, not far from the highest spot in Rhode Island. This location in the town of North Scituate was designed by Thomas Cave of the Federal Communication Commission's Radio Intelligence Division (RID). The RID had leased the 183 acre Stoddard Farm, chosen for it's location and open acreage that was amenable to a large wire array receiving station far from industrial and power line noise sources. Nationwide there were 150 such RID stations used to intercept wartime radio traffic. The [Chopmist](#)

[Hill station](#) had 85,000 feet of wire antenna curtains aloft. The poles were typically 80 feet high and were still aloft in 1968. Not being rotary antennas caused some problems with the strategic listening needs. During the critical Second World War battle of El Alamein in 1942, Cave was calling the Narragansett Electric Company several times daily to reposition antenna poles to optimize reception (truly the "armstrong rotor" method)! On another occasion the rhombics on Chopmist saved the Queen Mary carrying 10,000 American troops overseas by intercepting orders to sink her sent to the U-boat fleet in the Atlantic. The station was also credited to accurately pinpointing the location of every Axis spy within the US by triangulation with other RID stations. Curiously, Frank W3LPL (who had seen the site in the 60's) has told me that the site had a Swastika-shaped fireplace. I suspect as a reminder of their mission, although I am not certain of this. This site was later proposed as the potential site for the United Nations but was later passed up for New York.

Various commercial rhombic stations exist even today. One is on Cape Cod (Chatham) and is the receiving end of an HF relay link. One of the largest rhombic stations ever was on Long Island at Rocky Point and was an RCA station.

This station was off Route 25A. This station was operational until 1978 and at its peak had 137 rhombic antennas, many phased together. I have many insulators from this station, including some very distinctive custom-built 4-wire feedline insulators with brass/ceramic turning and termination insulators that were obviously built specifically for the rhombic station. Rhombic termination was accomplished with stainless steel wires strung up the middle of the rhombic. Other commercial stations have used "reentrant" termination, a term I have not yet found a definition for. Evidently reentrant termination permits the station to run unlimited power output without "frying" the termination medium (i.e. melting your stainless steel wire or your resistors)

[Click here to see the Rocky Point rhombic map with better resolution.](#)

Amateur radio operators still occasionally employ rhombic antennas. In fact, I began my involvement after one day encountering the Don Wallace, W6AM, rhombic station. I at the time was a teenager in Palos Verdes, California. I was riding my bike down a country road and came across a huge installation of rhombics each perched upon telephone poles, some over 150 feet tall! (he used two 75 foot poles spliced butt to butt with redwood and angle iron splices to hold these monster poles together, he also did not like to waste pole length by burying pole in the ground and instead used a metal spike inserted into the bottom of the pole to secure the pole to the ground). The station in 1945 had 120 acres of land (when Don purchased it) with 16 rhombics, the longest being 1500 feet (end to end) and beaming Asia (his favorite antenna). This 1500 foot rhombic is widely believed to have been the largest beam antenna ever in amateur service. He had 61 telephone poles, each at 80 feet and another 90 feed line poles (25 feet high each). These antennas were fed by 52 MILES of feed lines (#8 copperweld). Several of these antennas had 2 or 3 curtains (to smooth impedance and increase gain). In 1962, Don sold 95 acres and consolidated his antennas. He installed ten 140 foot poles on the perimeter of his remaining 25 acres with rhombics layered every 6 feet in various directions with rhombics beginning at the 90 foot level and going in layers of 6 feet up to 140 feet high.

[Click here to see the W6AM rhombic farm map image with better resolution.](#)

[Click here to read Don's handout he sent anyone inquiring of his rhombic farm](#)

Now his longest (and still favorite) rhombic was 1100 feet end to end. Overall these antennas now covered 16 directions using the 8 rhombics he installed. This was the station I bicycled by. Don showed me his station with the miles of curtains and feedlines stretching for as far as the eye could see and with an operator's desk with a separate Collins station per band. He had his linear amplifier in a cage behind the operator's station and you would tune the amp with a fiberglass rod. The antenna feedlines crossed the ceiling of the station and when you changed directions, you would turn a heavy bakelite knob on a rotary switch and the open frame relay matrix would chatter accordingly to your right. In the receiver you would hear various distant stations peak and fall as you electronically swept the horizon faster than any other operators could with their rotary arrays. Additionally, you would hear stations earlier during band openings and often you would communicate easily with far away stations others could not even hear. Nothing short of amazing. Don had an annual "open house" that was well attended. He always would fire up his spark gap transmitter especially for the occasion and demonstrate how a spark station sounded. I also recall [Don's KW mobile station in his convertible Cadillac](#) working Russian stations on the 495 Freeway at 60 MPH using an old bug strapped to the seat (on the way to Clifton's in downtown LA for the Southern California DX Association meeting). The code would sound slightly different as we would round steep turns

[Eventually, after Don's passing, the station was dismantled for condominiums \(Wallace Estates\)](#) and there is now a museum station there. At its closure, the W6AM station had made over 500,000 contacts. I have a few of the W6AM insulators with which to remember this now silent station.

The American Radio Relay League (ARRL) in Newington Connecticut (not far from my home) had a rhombic until 1989, when dry rot in its cedar support poles forced it to be dismantled (seems to be the fate of

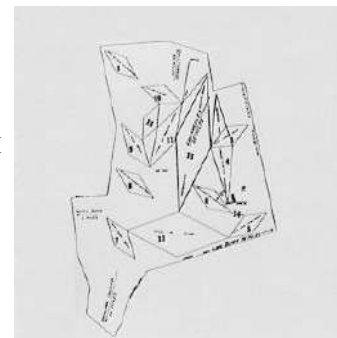
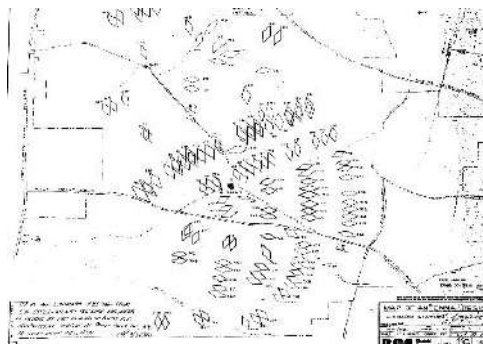

most rhombics at some point, they outlive their supports!).



[Click here to see the QST cover rhombic image with better resolution.](#)

[Click here to see the QST text description of the ARRL rhombic with better resolution.](#)

[Click here to see the image of the dismantling of the ARRL rhombic with better resolution.](#)

This antenna was supported at 65 feet and had leg lengths of 350 feet (theoretical gain of 17dbd on 14 Mhz) with a tilt angle of 70 degrees. It was oriented East-West and is said to have had a stomping signal (loudest in the US as the one wavelength height limited the radiation angle to 15 degrees, about right to be optimum for the 1500 mile hop to the West Coast).

More recently, during the Desert Storm engagement, a group in the Midwest set up a rhombic beaming the Saudi Peninsula to provide point to point communications for the Military Amateur Radio Service (MARS). Again, the rhombic was chosen because of it's excellent point to point communications ability. This rhombic was up around 100 feet high with leg lengths of 294 feet (theoretic gain 15 dbd) and a tilt angle of 70 degrees. This antenna was said to permit eavesdropping on "manpack" tranceivers on the ground with rudimentary whip antennas (I don't doubt this).

Lastly, my modest rhombics. I have a "baby" rhombic that is 377 feet long (end to end) with leg lengths of 210 feet beaming East-West. The tilt angle is 64 degrees and because it is only 40 feet high ("on the ground" in rhombic terms), the radiation angle is around 25 to 30 degrees (very loud to the West coasts of the United States and Africa to say the least!). I also have a rhombic on an unoccupied property that is a bit bigger: 288 feet leg length, 520 feet end to end with a tilt angle of 65 degrees. It is also a bit low at 45 feet (tree supports). Someday I aspire to install a few 90 foot telephone poles but am still trying to figure out an economical way of getting/installing same (any help from out there in internet land?).

As time permits I will be scanning some rhombic-related images in to place here on my page. Some links:

[Rhombic Antenna Design Software.](#) This software is included here courtesy of Orrin Winton WN1Z. This program is a windows app and allows you to optimize rhombics for desired wave angles and gain. You will need VBRUN300.dll to install this program.

[Visit Joby Wieser's Rhombic Ranch.](#) Joby has a number of rhombic antennas running

[Accumulated email related to rhombics and rhombic history](#)

[Plans for VHF and UHF Laporte rhombics](#)

[Read the original foreword of Harper's Rhombic Antenna Design textbook](#)

[Click here to read Harper's discussion of phasing pairs of rhombics](#)

[Click here to read Harper's discussion of lightning supression for rhombic antennas.](#)

[View the antenna patterns of various rhombic designs at various frequencies. I think these patterns bring a bit more clarity to how truly great the rhombic antenna really is.](#)

[American Radio Relay League \(ARRL\)](#) The League is an organization comprised of radio amateurs with diverse interests. They publish QST magazine. I have been an ARRL member for over 25 years.



Email me at: cummings7@mindspring.com



Return to my home page.

The Rooftop Tower

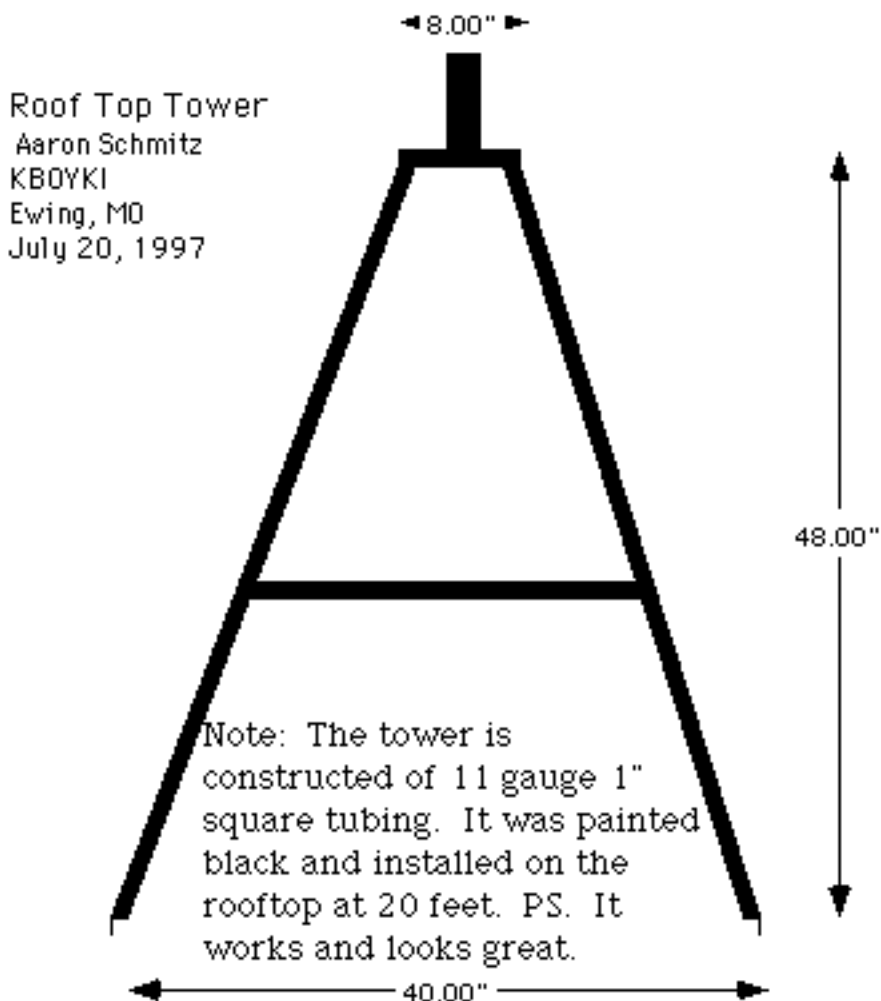

Common Amateur Radio Antennas

The J Pole

J Poles



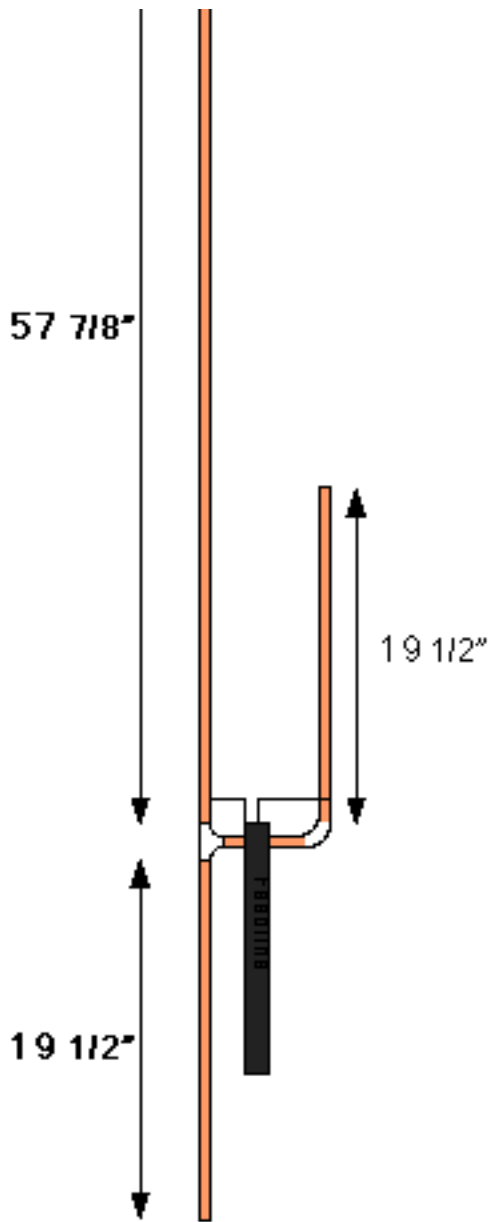

PLAIN J POLE

(DOUBLE J POLE)

Note: This antenna should be kept isolated from ground. Use PVC pipe as insulators on the long piece. If you need help send me a message.

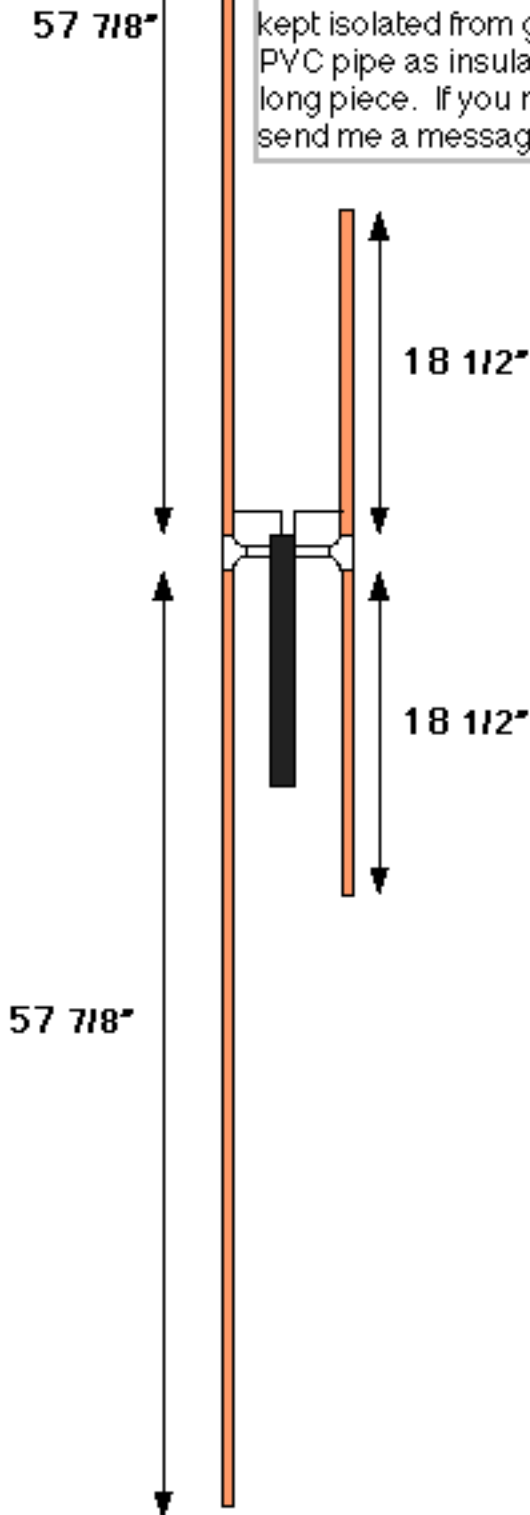

The Super J Pole

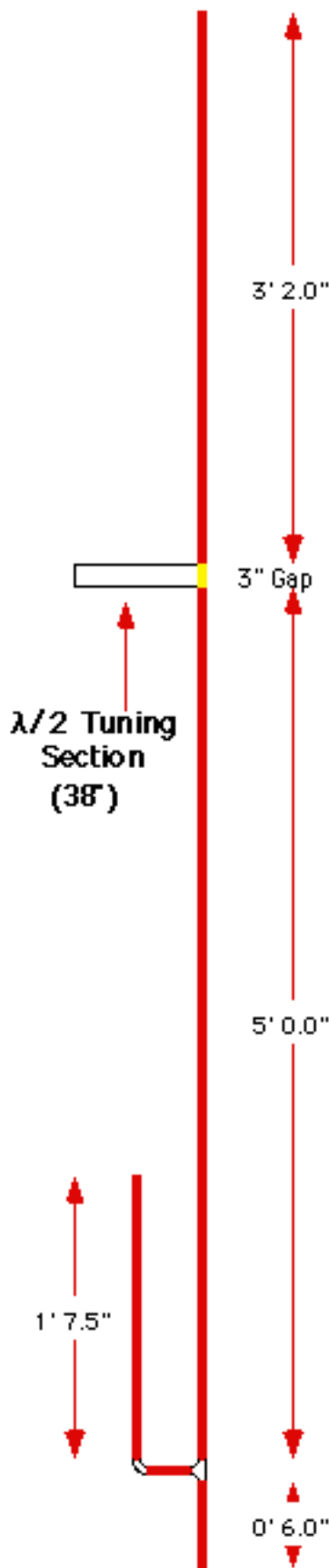

Super 2 Meter J Pole Antenna (a.k.a. Collinear Antenna) with helpful modifications by Aaron Schmitz, KB0YKI

Construction Details:

1. Cut copper to proper lengths.
2. Flux and solder bottom J Pole section.
3. Cut a 38" piece of 12 gauge wire.
4. Solder a 1/2" coupler on the top J pole section and bottom of the top $\lambda/2$ length of pipe.
5. Drill a 1/8" hole into each coupler through the pipe.
6. Strip back 3/8" of insulation on wire.
7. Insert wire ends into holes and solder.
8. Bend wire into a 3/4 circle around pipe with a 6" radius.
9. Insert 1/2" X 4" dowel rod into coupler.
10. Completely seal all areas from moisture. Paint it if you would like.
11. Attach coax and have fun!!

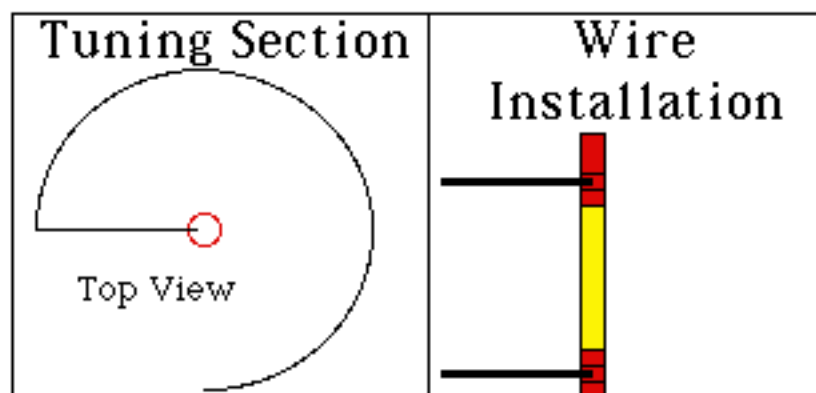

Omnidirectional

440-450 MHZ Omnidirectional Antenna
from
73 Magazine November 1994

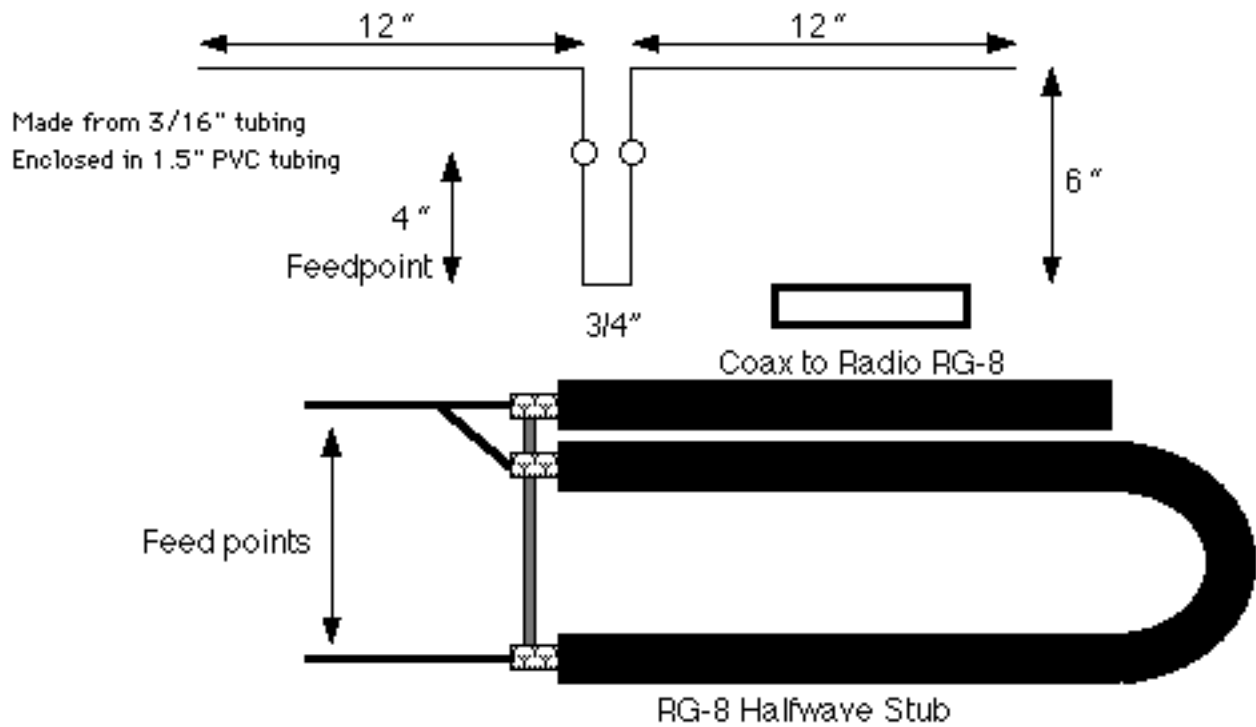

Yagi

| Element | Length | Spacing |
|------------|----------|----------|
| Reflector | 19.78*2 | |
| Driven | 19.25*2 | 15 5/16" |
| Director 1 | 18.25*2 | 15 5/16" |
| Director 2 | 17.125*2 | 15 5/16" |

Antenna Made from arrow shafts

Yagi

April 1992 edition of 73 Magazine

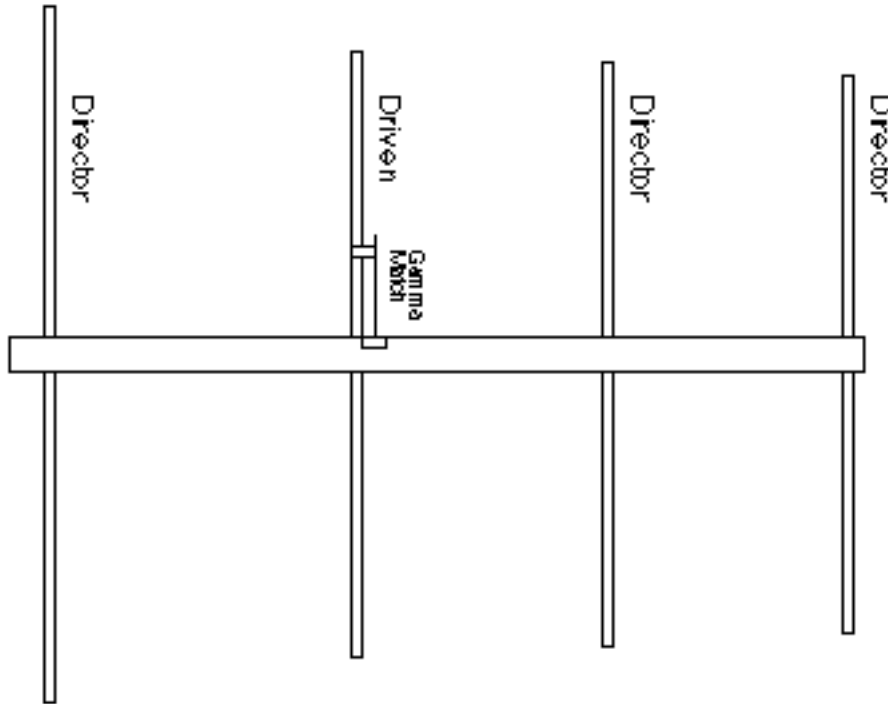

Quads

VHF AND UHF QUAD ANTENNAS

Plumber's Quad (4 Element

| | 146.000 | | 146.000 | | 446.00 MHz | |
|-----------|----------------|-----------------|----------------|---------|----------------|-----------------|
| | Element Length | Element Spacing | Element Length | Spacing | Element Length | Element Spacing |
| | (cm) | (cm) | (in) | (in) | (in) | (in) |
| Reflector | 216.000 | 40.000 | 85.039 | 15.748 | 27.983 | 5.182 |
| Driven | 206.800 | | 81.417 | | 26.791 | |
| Director | 200.700 | 39.600 | 79.016 | 15.591 | 26.001 | 5.130 |
| Director | 200.000 | 41.000 | 78.740 | 16.142 | 25.910 | 5.312 |

Quad Antenna 7 Element

Element Spacing 18"

| | 146.3 MHz | |
|-----------|----------------|-------------|
| | Element Length | Cross Piece |
| | (in) | (in) |
| Reflector | 86.000 | 30.000 |
| Driven | 82.000 | 28.500 |
| Director | 78.000 | 27.125 |
| Director | 77.500 | 27.000 |
| Director | 77.000 | 26.750 |
| Director | 76.500 | 26.625 |
| Director | 76.000 | 26.500 |

Element Spacing 6 in

| | 446.00 MHz | |
|-----------|----------------|-------------|
| | Element Length | Cross Piece |
| | (in) | (in) |
| Reflector | 28.206 | 9.839 |
| Driven | 26.894 | 9.347 |
| Director | 25.582 | 8.896 |
| Director | 25.418 | 8.855 |
| Director | 25.254 | 8.773 |
| Director | 25.090 | 8.732 |
| Director | 24.926 | 8.691 |

Quagi

Modified W5UN Quagi Design Optimized for 144.050 MHz

| | Element Le Spacing to element (inch) | (inch) |
|------------|---|---------|
| Reflector | 86.7500 | |
| Driven Ele | 82.0000 | 21.0000 |
| Director 1 | 35.9375 | 15.5000 |
| Director 2 | 35.7500 | 33.0000 |
| Director 3 | 35.3750 | 31.0000 |
| Director 4 | 35.2500 | 33.0000 |
| Director 5 | 35.0000 | 31.6250 |
| Director 6 | 34.8125 | 36.0000 |
| Director 7 | 34.6250 | 36.0000 |
| Director 8 | 34.6250 | 34.0000 |
| Director 9 | 34.5000 | 34.5000 |

Boom- Nonconductive material such as wood or fiberglass
 Quad Element made from 12 gauge insulated copper wire
 Yagi Element 1/8" solid aluminum rod cut to within 1/16"

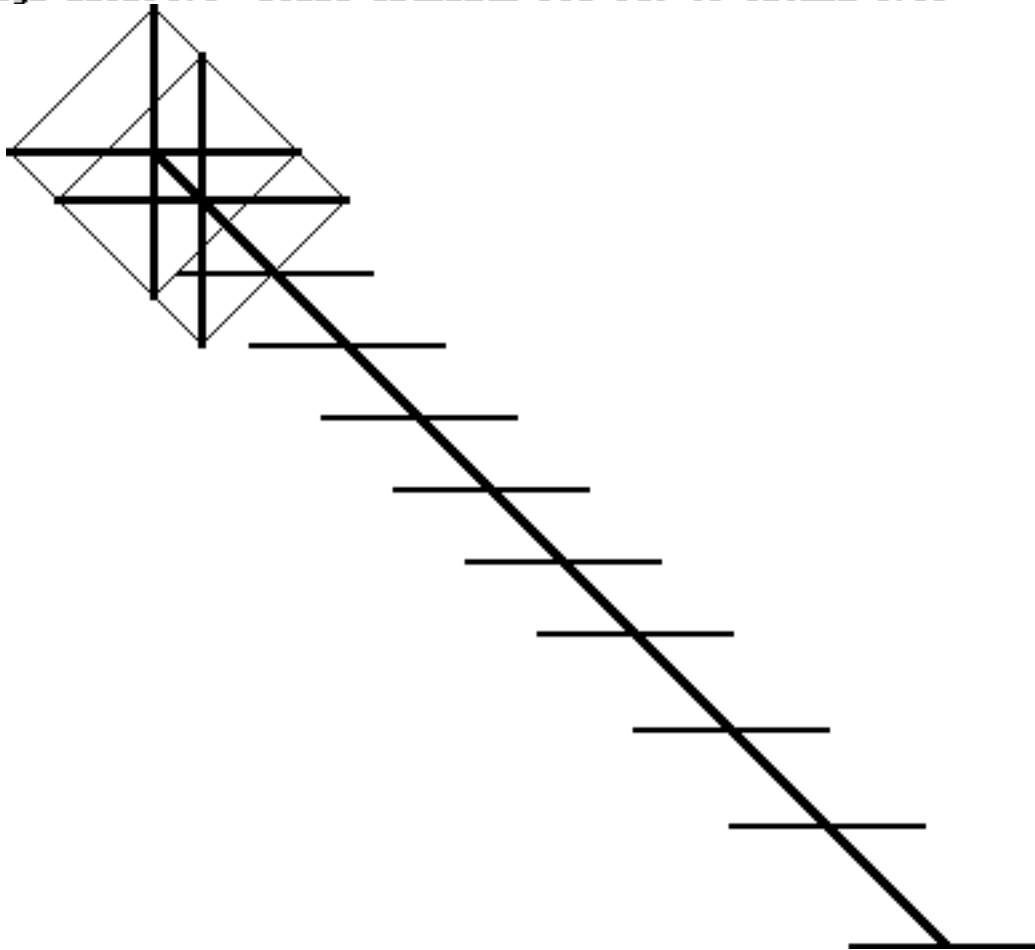

My Stacked Quads



The picture above is of my 440 MHz stacked quads. The spacing between the antennas is approximately 80-90% of the boom length. RG-59 (75 ohm) cable was used on the phasing harness. An almost perfect 1:1 SWR was achieved at 446 MHz after installation. Any other questions on this can be forwarded to me.

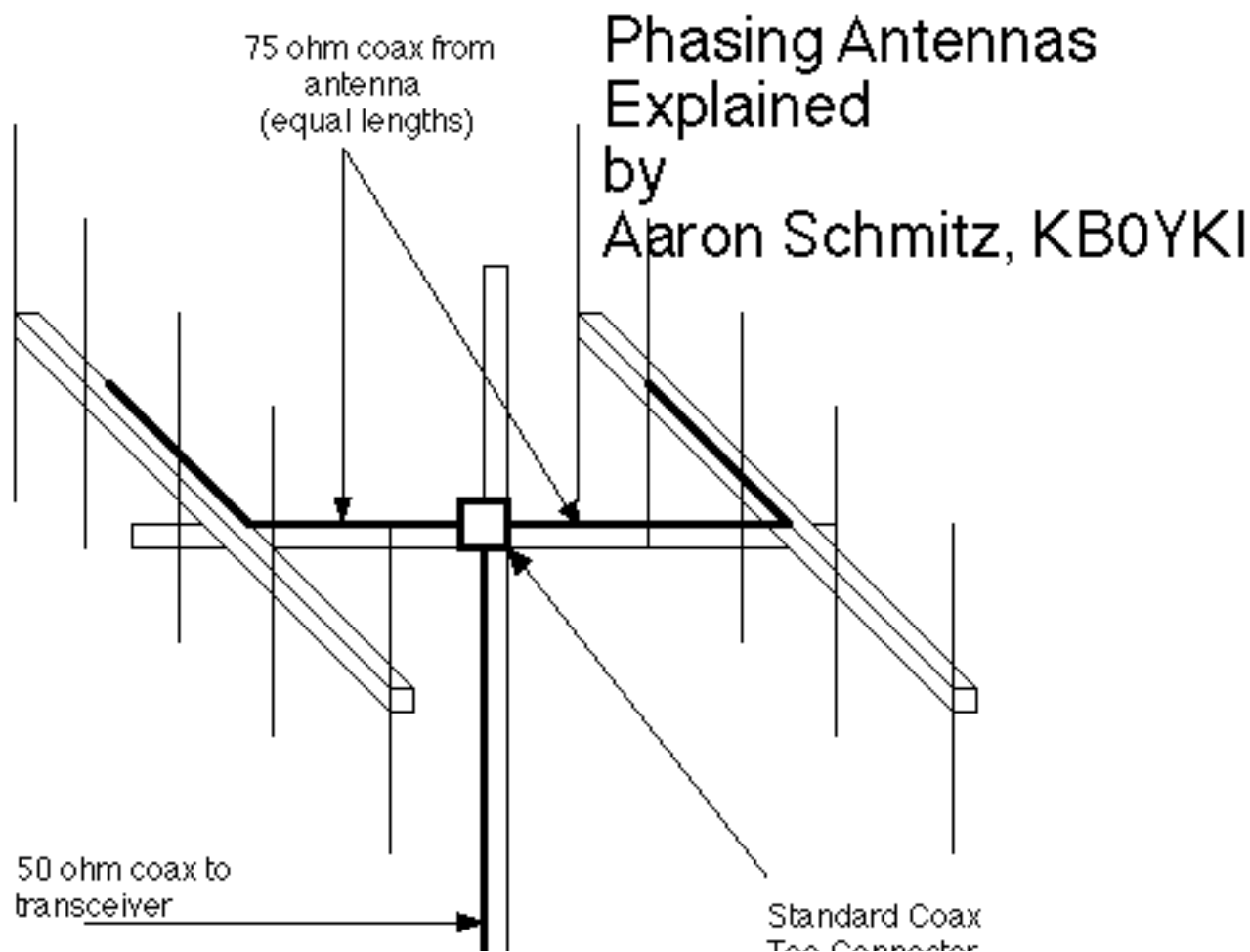

transceiver

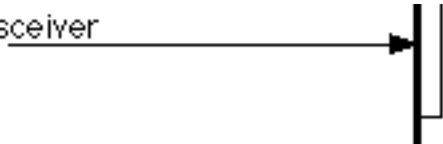
Standard Coax
Tee Connector**Steps to build a Phasing Harness**

- 1) Build the antenna and cross support
- 2) Determine the length of coax that you need to run from the antenna feedpoint to the connector.
- 3) See how much coax will work for the phasing harness.

$$f=146.520 \text{ MHz}$$

$$\lambda = \frac{234}{f} = \frac{234}{146.52} = 1.5 \text{ ft} = 18 \text{ inches (Physical } \lambda)$$

RG-59 Coax Velocity factor is 66% the speed of light.

$$(18 \text{ inches}) \times (0.66) = 12 \text{ inches (Electrical } \lambda)$$

Example: Your setup needs approximately 6 feet of cable to get from the feedpoint to the Tee connector.

The only problem is that 6 ft would be an even quarter wavelength (not good). All you have to do is go to 7 feet of RG-59 coax and you have 7 electrical quarter wavelengths(Fantastic). You should be pretty close to having a low SWR reading. That is not guaranteed, but it should be close.

- 4) Get your 75 ohm coax and cut it off pretty close to amount of coax needed(in this case 7 feet for each side.)
- 5) Solder on your PL-259 connectors with the appropriate reducer to the 75 ohm coax coax.
- 6) Hook everything up. If you are using a gamma matched antenna, adjust the gammas to get a low SWR reading.
- 7) Get on the air and have fun!!!

Dipole Feedpoint

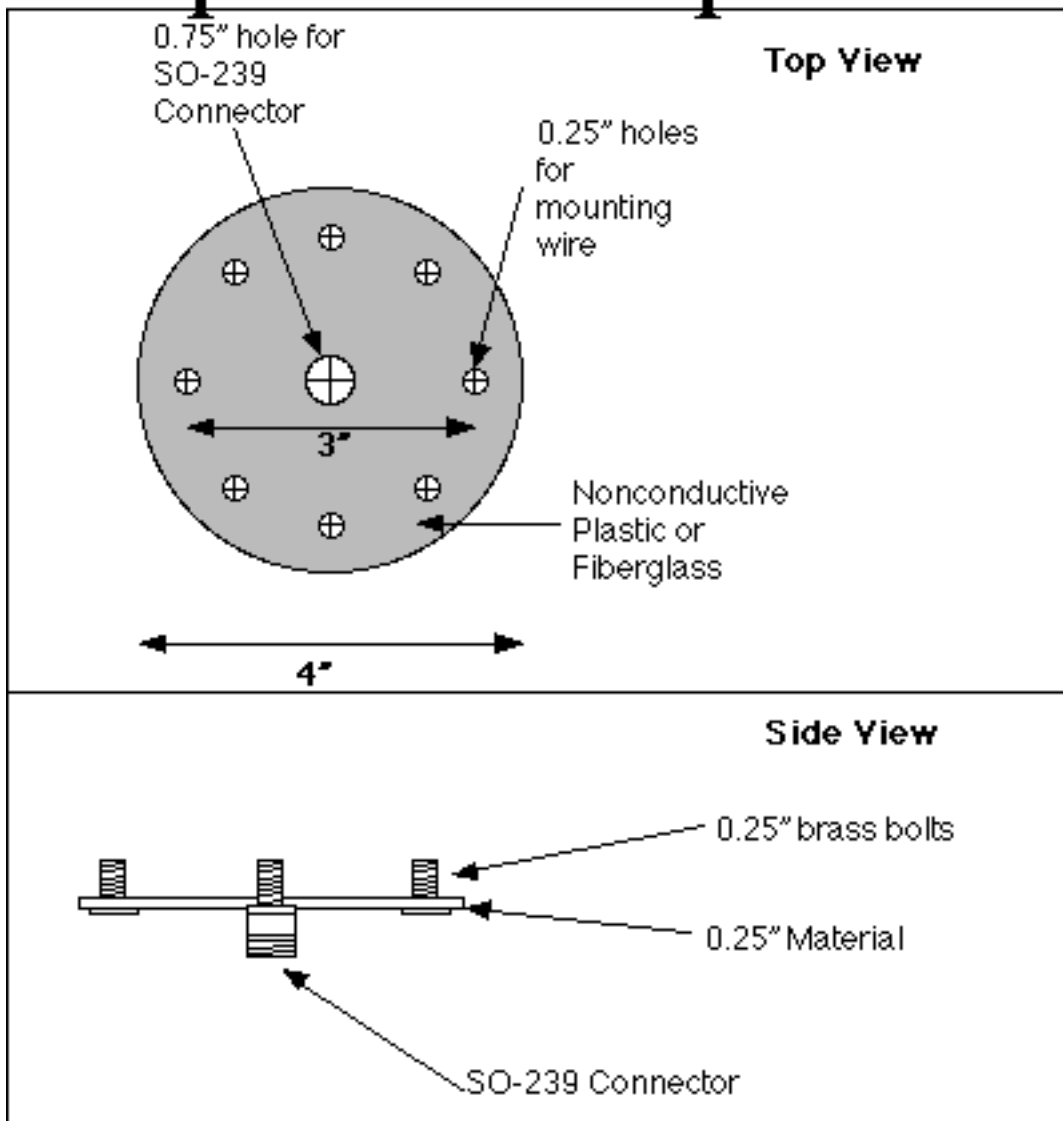

This is the big rooftop tower that I built a few months ago. At that time I could not find any in my area for a price I felt I could afford. It is made of 1 inch square tubing for the legs and uses a 2 1/4" inch pipe for holding the rotor. It is welded throughout and has two coats of enamel primer and two coats of flat black paint.

The tower has with stood the 50 mile per hour winds that have roared through Missouri in the month of April and May of 1997. If you would like a set of plans for this, feel free to email me.

[Return Home](#)

[GO TO HOME PAGE](#)

A ROTARY DIPOLE FOR 17 AND 20



After assembled a two element Quad, Mario (ik7zcg) needed an antenna for 17 and 20, so he asked me to build a 17/20 dipole; I hate rotary dipoles and traps..but why don't try it!

THE PROJECT

I hote projects because I never find all I need: so always I do the best I can with what I found.

At the beggining my project was:

- 1) Grounded-driven element;
- 2) Gamma-match feeding;
- 3) Traps with coax-cable;

After first test I decided to use a direct-feeding with no Gamma-match: the Gamma will give best results with single-band feeding. Dipole will be no more grounded.

THE DRIVEN ELEMENT

Driven element is tapered and I use 8 aluminum pipes with the following diameters:

| Diameter | Length | thickness | N.part |
|----------|-------------|-----------|--------|
| 30 mm | 162 cm | 2 mm | 2 |
| 25 mm | 164 cm | 2 mm | 2 |
| 20 mm | 131 cm * | 2 mm | 2 |
| 16 mm | 28 cm | 1 mm | 2 |

* here will be the trap (108 cm + insulator + 23 cm)

I suggest you to reduce thickness for tips (2 - 1,75 - 1,5 - 1 mm).

First part (diam. 30 mm) is center-insulated with a nylon bar (diam. 25 mm);

outside I used PVC (diam. 40mm, 5 mm Thickness); there are two screw bolt (3mm diam.) for feeding the dipole ([See Picture 1](#)).

The mast to boom attachment is an home-made steel plate (15x30x0,35 cm) ([See Picture 2](#)).

Second part (diam. 25 mm) is easy to assemble;

Third one is a little bit difficult: cut a 20 mm aluminum pipe (length 131 cm) at 108 cm so to obtain two pipes (108 e 23 cm).

Put a PVC bar (5cm) into and between them, then use fibreglass to block them and put over them an insulated support ([See Picture 3](#)) (TNX Antonio,ik7ytx).

Then make two 3 mm-holes (for traps-feeding).

Last part is a 28 cm length (diam. 16 mm) aluminum pipe, used for 20 mt tuning.

TUNING

Radiation resistance for an half-wave dipole will be around 69-70 ohm (free space); if you put it 0,5/0,75 lambda high resistance will be lower so you don't need to match it; I only used 20-25 turns of coax-cable as balun.

THE TRAPS

At the beginning I believed traps was the more difficult thing to build, so i bought two RF capacitor ([See Picture 4](#)) but that was not true!

Using a dip-meter check the resonance: 8 turns of RG58 on a 27 mm support will resonate at 18.1 ([See Picture 5](#)).

When tuned, cover the traps with RF glue ([See Picture 6](#)) so that water can't enter in and then cover all with PVC tape ([See Picture 7](#)).

ASSEMBLING



I tested the dipole on my garden, on a 10 mt pole, with no objectes near it. At first assemble first two partes (with no traps) and tune it on 17 mt; than add traps and 20 mt part and tune it on 20: S.W.R. will not change. On my garden S.W.R was 1,2:1 on 17 and 1,5:1 on 14.200, 2:1 on 14.000 and

14.350; when assembled in the qth of Mario it was 2:1 on 17 and 1,1:1 on 14.200 (but there are some objects near it, [see Picture 8](#))!

The length (half-dipole) is the following:

| | | |
|----------------------|-------------|----------------------------------|
| Tips (18 MHZ) | Trap | Half-Dipole (18 e 14 MHZ) |
| 46 cm | Trap | 394 cm |

WEIGHTH

Dipole's weigth is less than 6 Kg but you can reduce it reducing the thickness for aluminum pipes.

73 de iz7ath, Talino

RUBBER DUCK ANTENNAS

RACES BULLETINS 023-025, 1986

Rubber duck antennas on hand-held radios are a severe compromise on efficiency. On the plus side is their short size and flexible forgiveness to brutish handling. On the negative side is their terrible radiation inefficiency, probably worse than many of you expected.

When did you last replace your helical spring antenna we call the rubber duck? On testing a hundred or so portable radios that had been out on the fire lines for a few weeks we found a typical 60 percent failure rate. Most of the antennas looked fine. The only way you can detect an invisible rubber duck failure is by measuring the microvolts per meter with a calibrated receiver over a measured range under controlled conditions, such as done routinely by the Boise Interagency Fire Center. Since this is difficult for most to do, it might not be a bad idea to replace rubber ducks as a matter of course when they show signs of wear or if they are a year old. You might want to consider using a telescopic antenna under non-violent conditions to vastly improve the range of your hand-held.

The National Bureau of Standards ran some tests that proved what we had long suspected. The efficiency of a hand-held is dependent upon how much antenna it has and how good the ground plane. Most portables have very poor ground planes; the more metal the better. Also the more antenna the better. Hence the rubber duck is a woeful but often necessary compromise. But if a portable is not going to be subjected to the abuse of fireground or street cop utility, you should consider the telescopic quarter-wave antenna if range is important. Compare the figures and discussion that follows.

Be aware that the telescopic antenna is nowhere as rugged as the rubber duck but it will talk circles around it. You might say that the quarter wave whip is to the rubber duck what a 106 inch CB quarter wave whip is to a 36 inch whip on a base loaded coil to compromise range for low garages. Our reference antenna in the Public Safety high band and 2-meter Amateur radio measurements below is a quarter-wave telescopic antenna, extended, and held at face level: One-quarter wavelength extended and at face level = 0 dB One-quarter wavelength collapsed and worn at belt level = -40dB Rubber duck held at face level = -5dB Rubber duck worn at belt level = -20dB Translated, this means that a 5-watt hand-held with a rubber duck worn on the belt has an effective radiated power not of 5 watts but only .05 watt. Held at face level the radio has an ERP of 1.6 watt. 15dB is quite a difference!

In the material above we gave you facts and figures of the quarter-wave telescopic versus the rubber duck for Public Safety VHF Highband and 2-Meter Amateur handhelds. The 40 dB down for the nested telescopic relates to those commercial models where the telescopic disappears within the radio. Such an antenna won't break when it's nested but it won't receive worth a whoop either. In those radios where the collapsed quarter wave is external to the radio they break very easily. For that reason we recommend the style that has a spring at the base. The spring makes it very forgiving of elbows and other bum raps. We

have not researched or measured five-eighth wave antennas because they are too long for most public safety use and because they typically require too many telescopic sections. The more sections the more chance of troubles. Few people take the time to correctly telescope any hand-held antenna. They should never be whacked down with the palm of the hand on top and push. They should be pulled down with the thumb and first two fingers.

If you are interested in the figures for 450 MHz, using the table above, they are respectively 0dB, 30dB, 5dB, and 30dB. One more reference for the technically inclined-the loss of a telescopic antenna compared to half-wave dipole: VHF -5dBd and UHF -20 dBd. Telescopic antennas should be changed at least annually and whenever they become the slightest bit loose. Any looseness can mean a poor RF connection inside the antenna where you can't see it or fix it. Simply change it.

Archives of California RACES Bulletins are available via anonymous ftp at <ftp://ftp.ucsd.edu/hamradio/races>

The Home Page for the [State of California Governor's Office of Emergency Services](#) contains other information about emergency response in California and elsewhere.

Use your Back key to return to previous pages

[Home](#)[Up](#)[Feedback](#)[Contents](#)

The Slinky that became a Antenna

LOWER PRICE WAS \$35.00 NOW \$29.95

Fun with Helitrix™, the stretchy helix.-- Helitrix™ is a flexible springy helix with a 2-3/4 inch diameter. Each Helitrix™ weighs approximately 7 ounces. When collapsed it is only 2-1/4 inch long, but it can be stretched without deforming into a helix as long as 15 feet in length. An antenna made from a Helitrix™ is light, simple to suspend and extend, and easy to put out of sight when not in use.

Helitrix™ Antenna Basics.-- For a forty meter dipole, use a full Helitrix™ coil on each side of the feedpoint. Stretch to 15 ft. For 75 meters put two coils on each side and stretch the whole to about 30 feet in length. Presto! You will have an 80 meter dipole that fits in most attics or even in a motel room. A quick twenty meter dipole, can be made by stretching out a single coil to a length of 7 ft and feeding it with a delta match in the center.

Helitrix Antenna Performance.--Is Helitrix a wonder antenna? No. But it works. In a test on a state-wide 75 meter phone net, a 30 foot 80 meter Helitrix™ dipole at 20 ft received signal reports on average 1-1/2 S-units lower than a TNT Windom at 35 feet. That's not bad for a 1/8 wavelength antenna. The Helitrix dipole would have compared better had it been equally high, but it would not outperform the full size dipole. On the same occasion a comparison was made with a Hustler mobile whip. Compared with the whip, Helitrix performance and bandwidth were outstanding--better by several S-units for state-wide coverage. So, considering that you can even install a Helitrix™ antenna for 80 meters inside a motel room, the Helitrix antenna promises some good moments.

1. The simplest way to obtain multi-band results is to take a pair of Helitrix™ coils, one on each side of your feedpoint, stretch them as far as space permits, and clip on the feedline. Here you have a compact version of the good old "center fed Zepp". Feed it through an antenna tuner. This simple antenna will play on all bands 7 MHz and above. In a pinch it will permit QSOs on the 80 meter band. The ready-to go QRV Helitrix 40-10 antenna (see description below) is an aesthetically pleasing and easy to use version of this basic doublet.

2. Helitrix™ antennas are best suited to indoor or portable deployment. If you wish to put your Helitrix™ antenna outside on a more or less permanent basis, you should solder all connections well, then paint the whole antenna with spray enamel. This is actually quite easy to do, so don't shy away from trying it.

3. For a given Helitrix™ antenna, performance is best at the frequency of natural resonance and on the next harmonic because the coils act increasingly like an RF choke on the higher harmonics.

Have Fun with a Helitrix! But be careful the kids don't run off with it. They could slink around with it like a toy. But they'd miss the big fun. Could they imagine talking into one and having someone from Japan answer them on 15 meters? Or think of checking into MARS and RACES nets with a Helitrix™ on the bedroom wall? Only in amateur radio can you get a bang like this out of a stretchy helix.

Antennas & More has put together what you need to get off to a fast start with Helitrix™ experimentation. Check out the items listed below and turn a weekend with a Helitrix™ into the most fun you've had since you were a kid .

Helitrix™ Antenna TechNote 123D \$7 ppd.

This frequently updated Technote reviews Helitrix™ experiments performed to date. Gives detailed information on the electrical properties of Helitrix™ coil antennas. Describes instruments used & designs tested. Reports

unpublished experiences of numerous contributors. Shows how to get the most out of a Helitrix™ with or without an antenna tuner. Reviews what works and what doesn't. Use this to study out the principles and plan your installation.

QRV Helitrix™ Dipole \$29.95

This is the fully refined and ready to use QRV Helitrix™ system, all set to go for instant motel, attic, or portable use. Coaxial feedline is decorator white. Quick attachment clips make it a snap to hook up fast. Support line lets antenna slide in and out of action instantaneously. Unique design assures unerring and quick return to correct position whenever desired. Mounting tabs, coax feedline, and unobtrusive installation easy, whether for long or short term utilization. Manual shows proven methods for working 40 thru 10 even without an antenna tuner. With tuner work 80 meters.

Includes Feedline

Helitrix 40-10M Dipole antenna \$29.95**us**

Helitrix 80M Extension \$8.95**us**

[Review Cart](#)

[[Home](#)] [[Up](#)]

Send mail to webmaster@antennasmore.com with questions or comments about this web site.

Copyright © 1998 1999 2000 2001 2002 2003, 2004 Antennas & More

Last modified: April 11, 2004



Projects

Some tools, some rigs, some instructional, some published ... all interesting!

[About the AmQRP Club](#)
[Frequently Asked Questions](#)
[Kits](#)
[Projects](#)
[QRP Forums](#)
[Contesting](#)
[References](#)
[Links](#)

NorCal Projects

[CW Decoder Program for Your PC](#)

Full featured CW decoder program for your computer, by Grant Connell, WD6CNF *Download file updated! (3/9/04)*

[Crappie Antenna](#)

Use this collapsible fiberglass fishing pole as a neat antenna support, as Howard Zehr N9AHQ describes.

[Antennas](#)

Some rules of thumb for beginners, described by James Duffy, KK6MC/5.

[Software](#)

This is the (updated) set of BASIC programs mentioned in the article "RF Fun with the RF-1" published in the Spring 97 issue of QRPP.

[Toroid Design Tool](#)

... by Jack Ponton, GM0RWU

[NB610](#)

A homebrew 10m transceiver, by Wayne McFee, NB6M

[SMK-1 on 20 Meters](#)

Taking the venerable SMK-1 design to 20m and adding an RF amp, audio filter, and a TiCK Keyer ... by Wayne McFee, NB6M

[Solid State VXO, Buffer Amplifier, and Keying Circuit For Tube Rigs](#)

Useful accessory allow the use of smaller, modern crystal types to control and provide drive for tube rigs ... by Wayne McFee, NB6M

NJQRP Projects

[Digital QRP Homebrewing](#)

Home site for the article series on the Digital QRP Breadboard, the HC908 Daughtercard and other featured digital projects.

[Back to the Future: Tuna Tin 2 & Herring Aid 5](#)

_Vintage QRP transmitter & receiver projects resurrected & updated by NorCal

[Build the KA5DVS "PAC-12" Antenna](#)

A homebrew, multiband portable vertical antenna.

[Build a Logging Frequency Counter](#)

Turn the PSK31 Audio Beacon project into an SX28-based frequency counter that talks to your PC

[Antenna Analyzer I](#)

Here's the project that started N2APB & N2CX on the journey: an inexpensive scanning VCO and SWR bridge

[Simple Regen Receiver](#)

The N1TEV design from QST was built up by a rural Maryland Boy Scout troop, with great results.

[Portable PSK](#)

N2APB's quest for a portable, stand-alone controller that does PSK31 encoding/decoding on 80 & 40 without using a PC

[Summary of Sierra Mods](#)

A collection of modifications that can be made to the ever-popular Sierra QRP Transceiver

[How Low Can We Go, With a VXO](#)

I wanted to learn more about how a VXO with a wide tuning range could be used in either Direct Conversion or Superhet transceiver schemes.... by Wayne McFee, NB6M

[NB6M Homebrew DT Filter es TX](#)

... by Wayne McFee, NB6M

[NB6M Homebrew Receiver and Keying](#)

... by Wayne McFee, NB6M

[NB6M Homebrew VXO](#)

... by Wayne McFee, NB6M

[St. Louis Vertical](#)

... by Dave Gauding, NF0R

[St. Louis Vertical Updates](#)

... Compiled by Jerry Parker, WA6OWR

[NB6M Paddles](#)

... by Wayne McFee, NB6M

[Pixie-II](#)

_Collection of useful information for homebrewing this super simple QRPp transceiver

[MicroBeacon](#)

Collaborative project by NJQRP members featured a microcontrolled memory keyer with a controllable RF attenuator.

[Homebrew Kites](#)

This homebrew Scott Sled design from AA1MY takes HF antennas high into the air

[DDS VFO with AD9850 + PIC16C84](#)

N2APB homebrewed the classic DDS VFO project from WV2B published in July 1997 issue of QEX

[Cigarette Lighter RF Probe](#)

A QRP accessory for under \$10, by KW2R

[NN1G Transceiver Construction Notes](#)

KW2R describes his notes on this classic transceiver from Dave Benson.

[Antenna Musings](#)

Excerpts from a presentation N2CX gave at FDIM 97 describing portable antennas

[QRPpaddles](#)

WK8G details his marvelous little paddle design

[NorCal / K8FF Paddles](#)

Some notes and photos from N2WF concerning his construction of the NorCal Paddles Kit

[Z-Match](#)

Dave Maliniak, AA2A collects his notes and the original article on the venerable ATU design from W6JJZ

[The Perfect QRP Enclosures](#)

N2APB found a commercial enclosure that was perfect for many QRP station accessories

160m-10m Sterba Curtain

IF YOU COULD ONLY PUT UP ONE ANTENNA...THIS WOULD BE IT!

By NØKHQ - ST. LOUIS. MO

The Broadside Curtain Array

You can build them better than you can buy them!

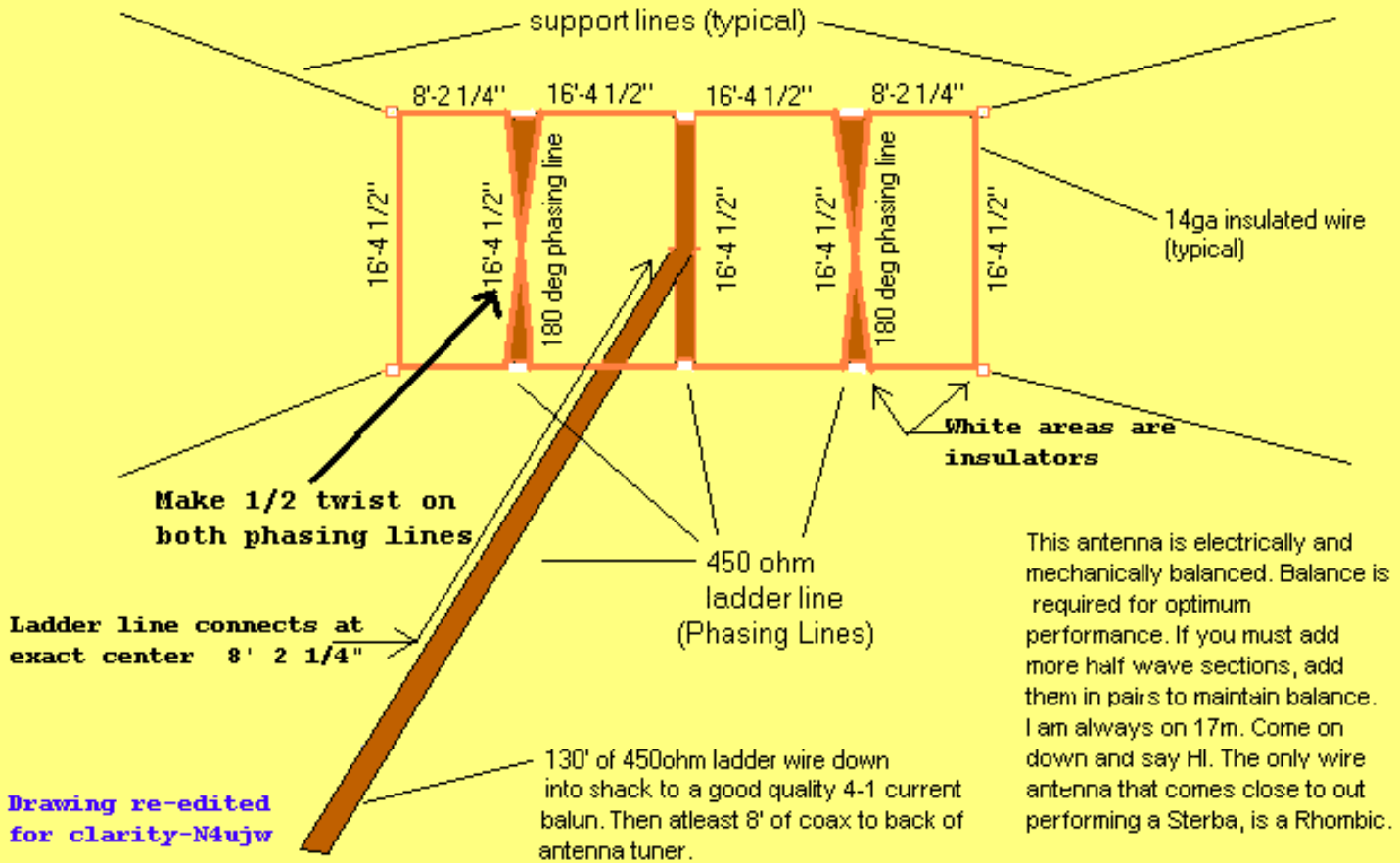

160m 1/4 wave

Home Depot sells aluminum chain link fence tie raps that are 8ga. They cready have a hook on one end these a great for holding the 1/4 wave pieces of 14ga wire down close to the ground. I use 14ga insulated wire at my QTH.

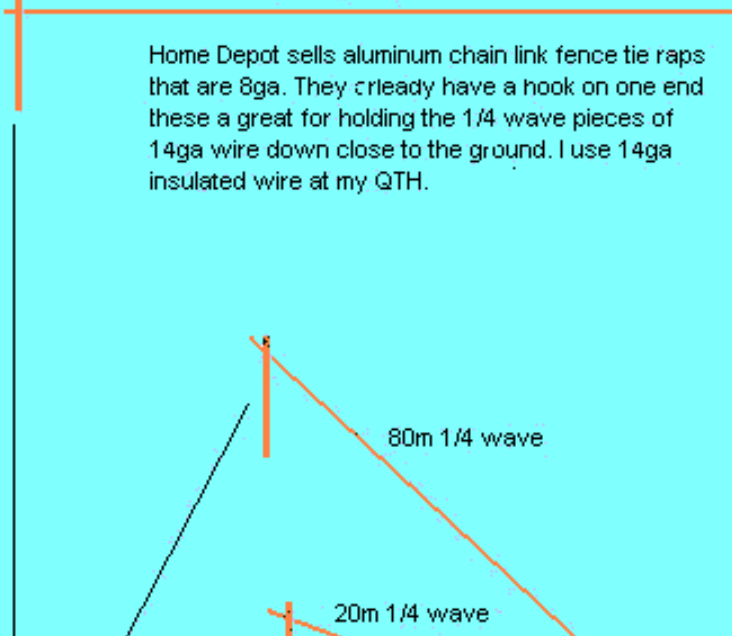

NØKHQ

Tunable Buried Radial System

Pound 2' pieces of 1/2" copper tubing into ground below grass level.

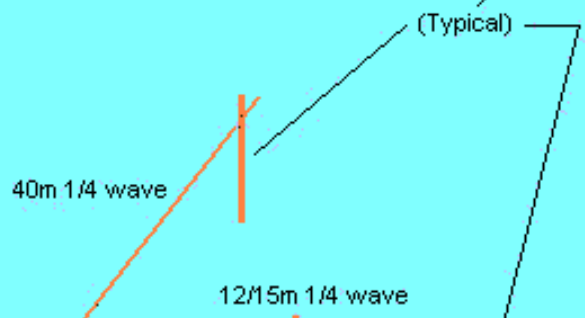

BUILD A STURBA CURTAIN ANTENNA FOR ALL HF BANDS!

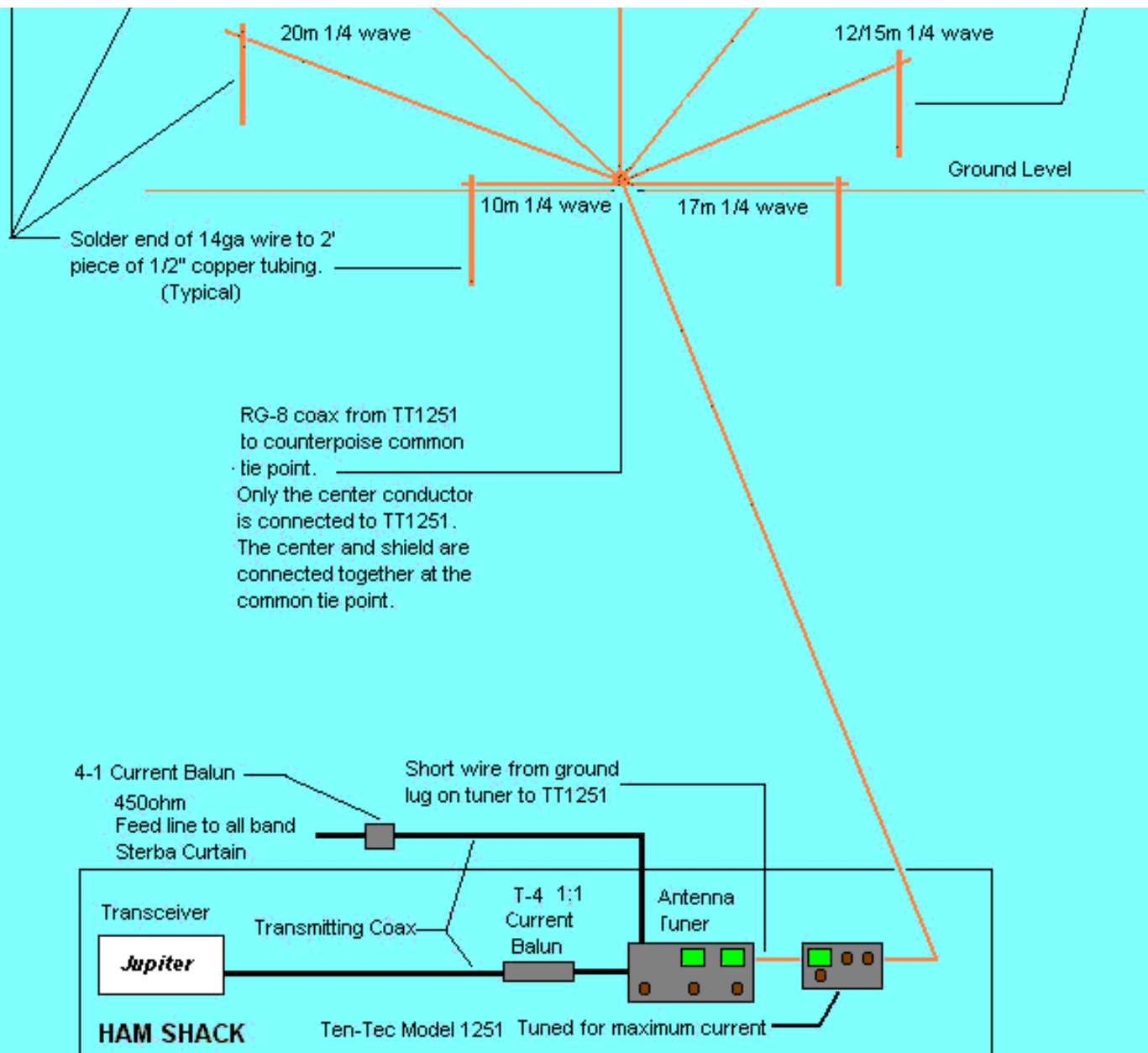

Sterba Curtain - Detail "A"

By NØKHQ

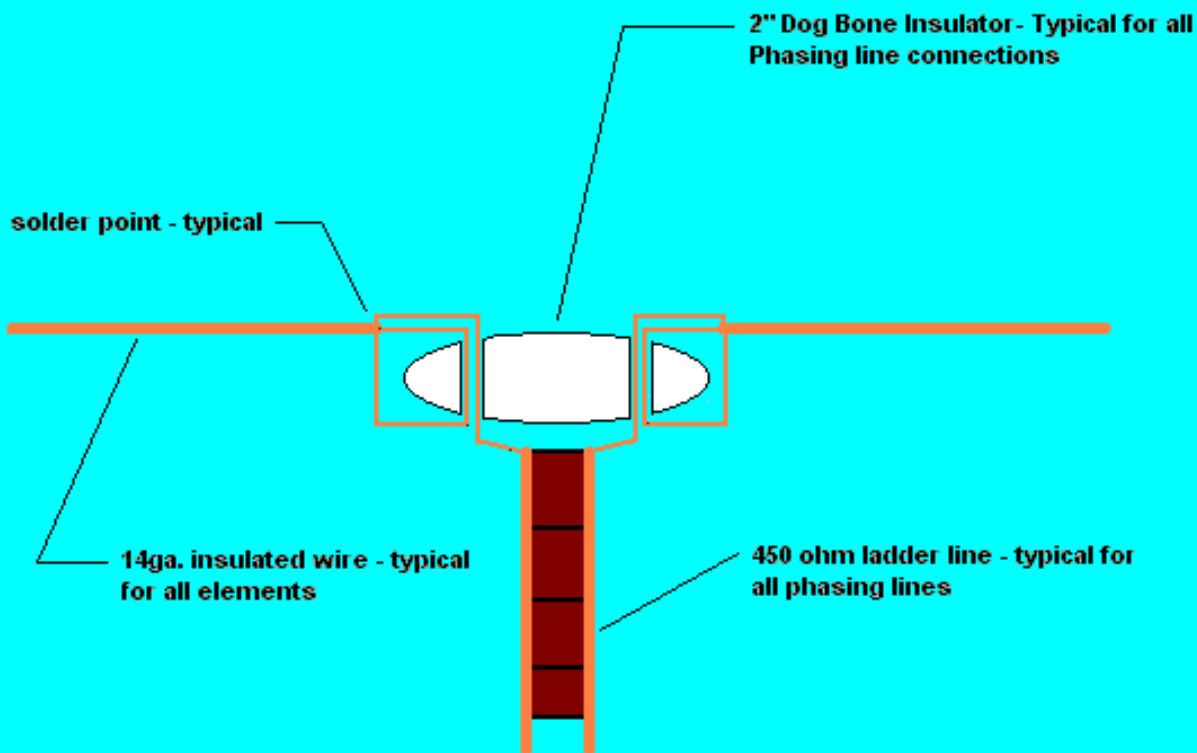

Note:

The element lengths are measured from the solder points. Make sure that you use coax seal at all solder connections.

The phasing lines are the only lines that have a 180deg. twist. (2)

"I live on a very small residential lot 65' wide x 100' deep. I have a tree in the front yard and a tree in the back yard.

The sterba is hung directly over the top of my house.

the bottom element of the array is up at 35'.

The design frequency for maximum gain was 28.5mhz

THIS DESIGN IS FOR ALL BAND USE.... 160 THRU 10 using a Tuner!.

The standard formulas below were used

$468/\text{freqmhz} = 1/2 \text{ wavelength section}$

$234/\text{freqmhz} = 1/4 \text{ wavelength section.}$

My antenna elmer is W1VDE, Roger, He was part of the team that built the dishes at Arecibo, Puerto Rico years ago.

I am attaching the other half of my antenna system(John is referring to the Tunable Radial System in pic below) for your review and comments. This system adds approx. 3db to 6db of additional gain to the Sterba.

If you need further information please do not hesitate to call.

Hams that have installed the curtain have liked it so much they have put up more than one."

John / N0KHQ / St. Louis

Always on 17M

Antennas:

You can build 'um better than you can buy 'um.

This taken from recent email from John, N0KHQ

Hi Don,

Okay, here we go. Here's an example for 17 meters.

The Sterba is approx. 50' long x 16' high.

Example Gain on 17m:

17m squared / 12.56 (4pi) = 23 sq. meters of aperture

50' / 3.28 (1 meter) = 15.24 meters

16' / 3.28 (1 meter) = 4.878 meters

15.24m x 4.878m = 74.34 sq.meters

$74.34 / 23.00 = 3.24 \log x 10 = 5.09 \text{ db} + 1.64 \text{ (gain over dipole)} = 6.73 \text{ db gain on 17m.}$

If you are running 150w x 6.73 = 1009.5 watts of effective radiated power output on 17m.

On 10m (the design frequency) the gain is 10db +/-

The above formula can be used for calculating aprox gain on other bands

I need to clear up something that I may not have explained very well. This design allows a ham to use this array on all bands 10m through 160m, **on 160m the swr bandwidth is pretty narrow..** There is no need to build arrays for different bands.

I have not tested other Sterba's designed for other bands as to their performance from 10m through 160m.

ABOUT FEEDLINE LENGTH

The reason the 450 ohm feed line is 130' is because it is about 1/4 wave length on 160m which is a high current point. So, what ever is tied to the end of the feed line.....is going to get out!.

For the feed line length (130') I have tried different lengths but 130' seems to be the minimum optimum length to get on 160 m.

Example:

I used $935/1.931=484.2' / 4 = 121.0'$. This is a 1/4 wavelength at 1.931mhz, in the example. Some have said that 450 ohm ladder wire is actually 400 ohm. Some have said the velocity factor is not .95. Man, who really knows?

This antenna serves me well. Since I only have room for one.

A good thing to remember is the phrase "Volumetric Efficiency".

I have sent this design to a number of hams, the design has made it all the way to Europe. If you would like to contact a friend of mine that is running this array his call sign is **KB4CCM, Bill**. He liked it so well he put up two!

(Bill, KB4CCM WRITES THIS ABOUT THE DESIGN..... TAKEN FROM AN EMAIL)

"If hams interested in the Sterba wish to contact me, (see email address below)

I would be glad to answer any questions that I can and give tips on construction. **As John has told you, I**

have taken down all of my other wire antennas (dipole, extended double Zepp and Half square) due to the performance and versatility of the all band Sterbas.

By the way, you may be interested in an article I wrote which is published in the ARRL Antenna Compendium # 7 now on sale. It is entitled '**The ODD QUAD**' and details instructions on how to build a strong and cheap (using locally available materials) two element Quad that can be installed and rotated without a man made vertical structure. **This Quad, along with the Sterbas, may be the only antennas I will ever need or use for the rest of my ham career.**".....**Bill KB4CCM**

BACK TO THE PROJECT

The buried radial system that is used with the Sterba adds approx. 3db to 6db of gain. Once you add this gain to the gain of the curtain, the total gain of the antenna system is 9db to 12db of gain on 17m.

A good reference book that is available that will help hams to understand the importance of a good buried radial system is "Low Band DXing" by ON4UN cost \$30.

Hams running the low bands are experts on antenna systems.

I call it my antenna bible.

Hope all this helps.....my head hurts!!!!!!

73

John / N0KHQ / St. Louis

Always on 17M

Antennas:

You can build 'um better than you can buy 'um.

Editor's note:

Many thanks to John, N0KHQ for sharing this information for all Hams to enjoy!

and to Bill, KB4CCM for standing by for any questions you may have.

If you have questions about this project please contact them via email at:

John, N0KHQ Email me [here](#)

Bill, KB4CCM Email me [here](#)

NOTE: THIS DESIGN is for ALL BANDS ---160 thru 10 Meters using a Tuner!

BUILD A STURBA CURTAIN ANTENNA FOR ALL BANDS!

The Broadside Curtain Array

THE TECHNICAL STUFF

GET OUT THAT CALCULATOR!

[Back to Antenna Lab](#)

(See "About feedline length" at bottom of article)

Antennas & More for HF antennas

NEW!

See John's

17 Meter Coaxial Moxon.
40 % reduction in size over
standard Moxon!

[Click here](#)

RADIAL SYSTEM INFO

The Sterba Curtain, as designed is non resonant.

There are a couple of bands where the swr will drop to 3:1.

The installation of the tunable buried radial system will help on 160m, 80/75m and 40m.

If I were you I would put out radials for those bands only.

4 for 160m

4 for 80/75m

4 for 40m

Remember, the radials should be cut at .15 of a wave not .25. There is a 10% shortening factor when radials are either on the ground or buried just below the grass level. By installing the radial system you will add 3db to 6db of gain to the gain on the curtain now. (ref. ON4UN - Low Band DXing)

I bought a HedgeHog from Lowes to dig the trenches \$50 and used, what I call chain link fence wire ties, the aluminum wire ties are already bent in the shape of a "U" and hold the wire down very nicely.

You wont need to run an amplifier with the antenna for good performance.



[HAMUNIVERSE.COM](http://www.hamuniverse.com)

Your Source for Ham Radio Fun and Information!

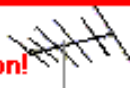

"Curtains for You"

As Forty Meters has traditionally been the most productive band on CW for our Club Field Day efforts, I would like to put up more than the usual dipole this year. The most attractive antenna appears to be a Sterba Curtain. I would ideally like the antenna design to center on 40, but this may not be practical. Perhaps we could design it for 30 Meters- that would be close enough to tune it and enjoy most of the benefits and gain of the Sterba.

My plan would be to put up the 2 section Sterba, run ladder line to a tuner in a temporary "dog house" to protect the antenna tuner in it, adjust the tuner at the center of the 40 Meter CW band, and run the needed length of feed line with coaxial cable to the Transceiver. Once tuned, we should be able to operate the whole 40 meter CW band without having to retune.

A two-section Sterba would be a full wavelength from end to end, and a half wavelength in height. Ideally, the bottom should be a half wavelength off the ground. At lower heights, it still has to be a lot better than a dipole. The 2 section Sterba should fit nicely between the stadium light poles. Provisions could be included to rotate the array.

Required materials would include:

1. A full wavelength of 450 ohm ladder line. For 40 meters this would be approximately 133 feet. For 30, this would be about 90 feet. Added to this would be a short section to the dog house.
2. 3 full wavelengths of wire. For 40 meters, about 400 feet, for 30, about 300 feet. I have been collecting wire, this should be no problem.
3. 8 Insulators (can be fabricated)
4. Tuner and Coax.
5. Rope- undetermined amount.

The Sterba Curtain: What is it, and what makes it so great?

The Sterba is a gain antenna, with the gain depending on the number of dipoles pairs. The unique signature of the Sterba is the use of ladder line with a half turn to provide the proper phase to the dipoles.

The basic Sterba unit is 2 parallel half wave dipoles with a half wave phasing harness between them. You may add as many units as you have wire and room.

The amount of wire in this antenna alone makes it a great receive antenna.



wire antennas

Antennas

Probably the best DX site in the world

DX news



More on the T2FD

Main
Design
Feeding
Compare
Opinion

Typical construction details for T2FD.
Actual dimensions calculated per formulas in article.

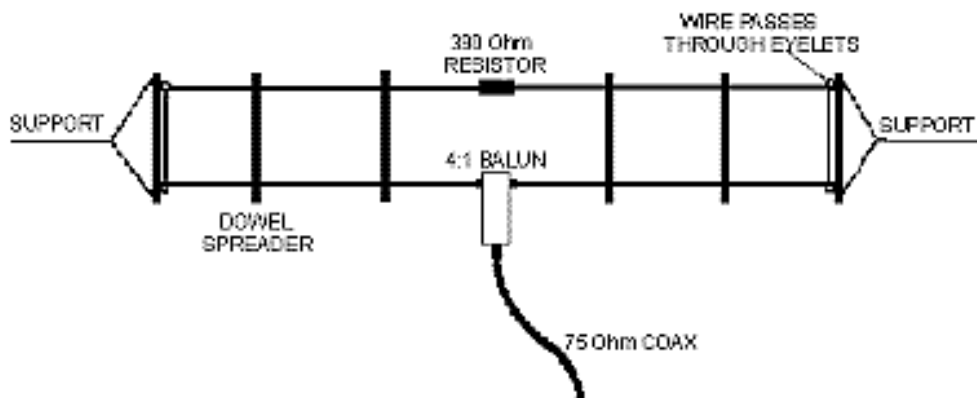

The formulas for calculating T2FD dimensions are as follows.

1. The length of each leg ("A") from the center is equal to 50,000 divided by the lowest desired operating frequency (in kHz) and then multiplied by 3.28. The answer is in feet.
2. The spacing between radiating wires ("B") is equal to 3000 divided by the lowest desired operating frequency (in kHz) and then multiplied by 3.28. The answer is in feet.
3. The sloping angle for a non-directional pattern should be on the order of 30, but 20–40 is acceptable.

Example:

To design a T2FD for the center of the 90 meter band (3300 kHz) and up:

| | Desired frequency | Spacing |
|---------|-------------------------------|------------|
| Leg "A" | $(50.000 / 3300) \times 3.28$ | 49.70 feet |
| Leg "B" | $(3000 / 3300) \times 3.28$ | 2.98 feet |

Total length of the antenna would be 99.4 feet (2 x 49.7), and the width would be 2.98 feet ("B").

The total wire used to complete the loop equals 204.76 feet (4 x 49.7)

[Front page](#)
[DX News](#)
[Logs](#)
[Andes DX](#)
[Antennas](#)
[DX Lab](#)
[In Print](#)
[Web Stories](#)

Archives

[Web Archive](#)
[Mail Archive](#)

Search

[Search all HCDX mail since 1995](#)

About us

[About us](#)
[Write to us](#)
[Copyrights](#)
[FAQ](#)
[HCDX mail list](#)

+ (2 x 2.98).

© Copyright worldwide by [Proceedings](#) and author.

[antennX](#)

[Cebik](#)

[FM antennas](#)

[Werner's links](#)

[Antenna Elmer](#)

[Coax basics](#)

[DX-Tools.com](#)



Open links in new Window

***OPERATING******MODES*****QUICK FIND**

| | | | |
|--|---------------------------------|------------------------------------|-----------------------------------|
| AM | GPS | Meteor Scatter | Pedestrian Mobile |
| AMTOR | GTOR | Microwave | PSK31 |
| APRS | HandiCapped Ham | MMTTY | QRP |
| ATV SSTV | Hell Modes | Mobile, Auto, RV | RTTY |
| Bicycle Mobile | HF Digital | Modes Of Operation | Satellites |
| CLOVER | HF DX | Modulation | Software |
| CW | HF Packet BBS | Morse Code | Spread Spectrum |
| Digital | HF Radio | Motorcycle Mobile | SSB |
| ECHOLINK | HF Portable | MFSK16 | SSTV |
| Emergency Radio | ILINK | MT63 | THROB |
| EME, SETI, Astronomy | IRLP | NAVTEX | T-Hunts |
| FAX | Laser | PACKET | VHF DX |
| FM & PM | Low Freq | PACTOR | WEFAX |
| | | | WIRES II |

**MODES OF OPERATION THESAURUS**

[How Modulation Modes Work](#) -- Very Visual Explanations for AM, FM, SSB, DSB, QAM

[Telecommunications Glossary](#)

[Modulation Codes -- A1A, etc](#)



AMPLITUDE MODULATION



[The AM Window Pages -- Audio, Events, Freqs, Nets, Resources, Technical](#)

[The AM Window --Loaded with goodies for the AMer](#)

[AM Expained](#)



CW AND MORSE CODE



[Go To The CW Page -- 20 Links to CW Trainers, Aids, 200 Practice QSO's, History and Much More](#)

Handi-Hams -- Handicapped, Visually Impaired

[Courage Handi-Ham System](#)

[Power/SWR Meter For The Sightless -- From RF Applications](#)

[ARRL Amateur Radio for the Blind -- Many Articles](#)

[ARRL SourceBook for the Disabled](#)

[GPS System For The Sightless](#)

[Wheelchair Accessible Minivan, the Vision™.](#)



HF MOBILE



[Mobile Mail List Reflector](#) -- Subscription Info

[HF Mobile Of The Month](#) -- Via K2BJ

[HF Mobile Message and Discussion Board](#) -- From K2BJ.COM

[HF Mobile](#) -- **A San Diego Mobile** -- From KA6WKE -- Great Installation Tips

[Great Mobile Installation Tips](#) -- From Alan Applegate, KØBG Via eHam.Net

[Home of HF Mobile on the World Wide Web!](#) By K2BJ

[Automotive Noise Elimination](#) By Stuart Downs. **WY6EE** -- A Must Read

[Solving Ignition Noise RFI](#) - Via The ARRL

[Noise Suppression Techniques](#) - From K2BJ

[Grounding Concepts and Techniques](#) - From K2BJ

[Automobile Articles](#) - Via The ARRL

[NX7U Mobile Pages](#) -- Check This Out

From The News Groups:

Someone asked me to post the following summary of three California 75m Mobile Shootouts:

Bugcatcher/Screwdriver with top hat 0 dB reference

Bugcatcher/Screwdriver, no top hat -3 dB, -50%

Hustler -7 dB, -80%

Outbacker -9 dB, -88%

Hamstick -12 dB, -94%

Whip with autotuner -14 dB, -96%

Considering that the top legal 75m mobile antennas are only 5%-10% efficient to begin with, a Hamstick radiates ~0.6 watts in the far field with 100 watts input. 75m Hamstick users must really enjoy QRP. :-)

--

73, Cecil <http://www.qsl.net/w5dpx>

MOTORCYCLE, BICYCLE, AERONAUTICAL, AND PEDESTRIAN MOBILES

[Motorcycle Amateur Radio Club -- MARC](#)

[Motorcycle Mobile Forum -- From eHam.net](#)

[Motorcycle Special Events Team -- Texas Style](#)

[Bicycle Ham Pages](#)



[Bicycle and Pedestrian Mobile Pages - Via HF Pack - The Portable Group](#)

[Pedestrian Mobile - From W3FF](#)

[Aeronautical Mobile Page](#)

HF PORTABLE

[Goto The HF Portable Pages](#)



HF RADIO



[HFRADIO.ORG](#) -- Propagation, DX, Callsign/QSL routes, Swap and Shop, Online Map Creation,
Learning / Licensing -- By NW7US, Tomas

LOW FREQUENCY OPERATION

● [LOWFERS Longwave Club of America](#). -- The World of Radio Below 500 kHz

● [Low Bands](#) -- 160, 80, 40, and 30 meters From K3KY



[160 Meter Mail List Reflector](#) -- Subscription Info



QRP OPERATION



▶ [Go To The QRP Page](#)



HF DIGITAL AND PACKET RADIO



[What Digital Signals Sound Like](#) -- Many many digital signal sounds -- From World Wide Utility News

[Another Digital Modes Sample Sounds](#) -- listen to the sounds -- from KB9UKD

[FYI: GENERAL DIGITAL MODES DESCRIPTIONS - On Line Sounds](#)

[ALSO SEE PSK31 SOFTWARE](#)

[Digital Signals FAQ](#) -- Loaded -- From WUN

[About Digital Ham Radio](#) -- From NB6Z

[AMTOR](#) From NB6Z

[CLOVER](#) -- From Hal Communications

[CLOVER](#) -- Jim's Digital Gazette By N2HOS

[**GTOR From NB6Z**](#)

[**G4GUO's Charles Brian digital SSB protocol. From G4GUO**](#)

[**G4GUO's Charles Brian digital SSB protocol. -- AOR Version From KQ6EH**](#)

[**HELL Modes From NB6Z**](#)

[**IRLP, ILINK, ECHOLINK, WIRES II**](#)

[**MFSK16 From NB6Z**](#)

[**MT63 From NB6Z**](#)

[**THROB From NB6Z**](#)

[**Packet Software -- Several to choose from**](#)

[**Tucson Amateur Packet Radio -- TAPR, All About Packet, APRS, DSP, Kits & projects**](#)

[**North American Digital Systems Directory -- From TAPR**](#)

[**Superb Packet Tutorial -- by Larry Kenney, WB9LOZ**](#)

[**Packet Radio Training Course -- From The Ventura County ARES AREA 6 Training Group**](#)

[**Another Great Packet Tutorial -- by Lincoln ARC**](#)

[**Still Another FB Packet Tutorial -- Buck Rogers K4ABT**](#)

[**Great Packet Listings -- From The QRZ Folks**](#)

[**Packet dot Com -- Loads of Packet info**](#)

[**US Packet Net -- Lots Of Packet Info**](#)

[**PacketZone -- From Jan, DG1LJP - portal for Packet Radio-Users and offers a lot of links.**](#)



[**Packet Glossary -- The Original By Buck Rogers K4ABT**](#)



[TAPR & Packet Mail List Reflector -- Subscription Info](#)

[Broadcast protocol in packet radio. -- Via TAPR](#)

[PACTOR NEWS -- Phil Sussman - N8PS](#)

[PACTOR Without A TNC -- From Tom Sailer, HB9JNX](#)

[PACTOR-II -- SCS Home Page -- The Works - includes a FB FAQ](#)

[Jim's Digital Gazette By N2HOS -- All about digital modes--RTTY, Amtor, Pactor, Clover, G-tor](#)

[HF Digital Radio -- Well Done Tutorials and Operating Info -- By NB6Z](#)

[HF Packet BBS's -- Try The Following Frequencies](#)

[14,105.5, 14,095.2, 10,149.25, 10,147.25, 7091.5 and 7103.5](#)

[Tucson Amateur Packet Radio Corp. -- THE definitive Source](#)

[North American Digital System Directory -- BBS, DX Packet Clusters, Nodes, Maps](#)

[AX.25 Amateur Packet-Radio Link-Layer Protocol --Via TAPR](#)

[Great Packet Page -- By G. E. "Buck" Rogers Sr K4ABT](#)

[Portable Packet Web Page ! -- By N1RWY -- Includes Baycom version 1.4 and Baycom version 1.5](#)

[MMTTY - Sound Card RTTY!!](#)

[MMTTY - program](#)



[RTTY Reflector -- Subscription Info](#)



[RTTY Software](#)



[RTTY Fan Club - Lots Of RTTY Info From Sotiris SV1BDO](#)



[ARRL RTTY Transmissions -- Schedule](#)



[RTTY DX News -- From Jim's Gazzette](#)



[RTTY HINTS -- From Kantronics](#)



[RTTY Loop -- By Marc I. Leavey, M.D. WA3AJR](#)



[RTTY Pages -- Including DXing, Contesting, Software Reviews -- From N1RCT](#)

PSK31

[SEE SOFTWARE FOR PSK31](#)

Has Awards and General PSK31 Pages as Well

[APRS San Diego](#) -- Via SANDRA

[APRS Primer](#) - Via SANDRA

[APRS Station Locations](#) - findU.com -- A must see -- shows APRS Stations, maps, position, much more, all across the USA!

[APRSPoint](#) -- Mapping Software Program -- From [KF6ZDM](#) --- With APRSPoint, you don't have to scan maps any more!!!



[APRS Mail List Reflector](#) -- Subscription Info

 [APRS](#) -- Automatic Packet Position Reporting System -- Lots of Info & Links

 [APRS](#) -- From TAPR

 [APRS](#) -- Tri-State APRS Working Group

 [APRS](#) -- Kansas City APRS Working Group



GLOBAL POSITIONING SYSTEM



**Yogi Berra Once Sed To His Wife
"I think we're lost but we're making good time"!**



GPS Made Easy : Using Global Positioning Systems in the Outdoors by Lawrence Letham

[Buy the Book Today!](#)



GPS Land Navigation; A Complete Guidebook for Backcountry Users of the NAVSTAR Satellite System by Michael Ferguson, Randy Kalisek, Leah Tucker

[Buy the Book Today!](#)



A Comprehensive Guide to Land Navigation with GPS by Noel J. Hotchkiss

[Buy the Book Today!](#)



GPS NOW 10 TIMES AS ACCURATE -- Need URL Explaining this -- anyone??



[The Global Positioning System](#) -- By Robert A. Nelson



[GPS](#) -- From USNO GPS Timing Operations



[GPS Primer](#) -- From The AeroSpace Corp.



[GPS Mail List Reflector](#) -- Subscription Info

● [GPS](#) -- Global Positioning System Overview-- From Peter H. Dana Department of Geography, University of Texas at Austin



[GPS Time Series](#) -- From NASA



[NAVSTAR GPS Operations](#) -- From The Time Service Dept., U.S. Naval Observatory



SLOW SCAN TV



[SSTV & ATV Mail List Reflector](#) -- Subscription Info

● [MMSSTV](#) - Sound Card SSTV!!

● [SSTV](#) -- From Wayne's World -- Click on "Ham Radio" -- Lots of Programs & info

● [SSTV](#) -- Excellent Slow Scan TV Page -- From PA3GPY

● [G0ITP's SSTV Page](#) -- All About SSTV -- Numerous Links

● [W5NCD's SSTV Web Page](#) -- Well Done SSTV Pages

● [FMSSTV](#) - mostly about SSTV, slanted toward FM 2 meter -- From Guy Clark, AB0DP

● [Radiofax, Wefax, Pressfax, Photofax and Amateur, SSTV](#) -- By Marius Rensen

● [ON4JU SSTV Website](#)

● [ALSO See SSTV Software](#) -- Several To Choose From



FAX & WEFAX



- [World Wide Marine Radio Facsimile Broadcast Schedules](#) -- From NOAA
 - [National Weather Service \(NOAA\)](#) -- Marine Home Page
 - [WEFAX Frequencies](#)
 - [WEFAX](#) -- From Kantronics
 - [WEFAX - Mscan Meteo](#) -- Program for high resolution weatherfax reception.
 - [Radiofax, Wefax, Pressfax, Photofax and Amateur, SSTV](#) -- By Marius Rensen
-



METEOR SCATTER



- [High Speed CW Meteor Scatter Pages](#)
 - [Operating Meteor Scatter Mode](#) -- From The Six Meter World Wide DX Club
 - [WSJT Meteor Scatter Programs](#) -- by K1JT
 - [Working DX on a Dead 50MHz Band](#) Using Meteor Scatter -- Palle Preben-Hansen, OZ1RH
-



FAST SCAN TV -- ATV



- [ATV From France](#) -- ATV repeaters in south of France, frequencies, modulations, used in France and in Europe -- From André F5AD
- [Amateur Television and High Speed Data Signaling](#) From F4DAY

- [Amateur Television Network](#) -- Atlanta
 - [ARIZONA AMATEURS ON TELEVISION](#) From KB7TBT
 - [British Amateur Television Club](#) -- With Amateur TV related software available for download
 - [IK1HGI PAGES](#) - TELEVISION AMATEUR ATV
 - [Klamath Amateur Television](#) -- Southern Oregon ATV
 - [OH3TR ATV Pages](#) -- Many Excellent Links and Tech Data
 - [VE7RTV ATV Repeater](#) -- British Columbia Television Group Website
 - [San Francisco Bay Area ATV](#) -- WA6ZJG
-



LASER COMMUNICATIONS!!!



- [Lasers](#) -- K3PGP Experimenter's Corner From VLF to Light
- [Amateur Radio Laser Communications](#) -- From Jim Moss, N9JIM/6



[Laser Mail List Reflector](#) -- Subscription Info



MICROWAVE & SPREAD SPECTRUM



- [SAN BERNARDINO MICROWAVE SOCIETY](#) -- DEDICATED TO THE ADVANCEMENT OF COMMUNICATIONS ABOVE 1000 MHz
- [Microwave Page From WA1MBA](#) -- Devoted to Amateur Radio Microwave interests including the MICROWAVE REFLECTOR.

- [Microwave](#) -- RSGB Microwave Committee - Loads of uWave Goodies
 - [Microwave](#) -- The World Above 1000MHz From G3PHO Peter Day Sheffield
-
- [Spread-Spectrum Radio Design](#) -- Via TAPR
 - [Spread Spectrum](#) -- TAPRs Spread Spectrum Communications Page
 - [Spread Spectrum Scene - Online](#) -- By KC6YJY, Randy Roberts
-

VHF DXING



[VHF Mail List Reflector](#) -- Subscription Info



[North East Weak Signal VHF Group](#) -- The Works On VHF, Contests, Grid Square Maps, Calculate Your Grid Square

[Hawaii Tropo Ducting](#) -- From KH6HME



TRANSMITTER HUNTING



- [Jerry Boyd's T-Hunt Web Site](#)
- [Hudson Valley DFA](#) -- Includes Home Brew Projects
- [Homing In](#) -- From KØOV
- [DOPPLER D/F INSTRUMENTS](#) -- From WB6EYV
- [Stalking the elusive "T"](#) -- Southern California Transmitter Hunts

● [Doppler Systems Inc.](#) -- Designs and manufactures radio direction finding equipment for amateur use

● [MicroFinder Doppler RDF](#) -- From AHHA! Solutions



NAVTEX



Note that some Ham TNC's and Software are capable of receiving NAVTEX Broadcasts. See manufacturers pages and software pages. These broadcasts are easily received and decoded provided you are within range of a NAVTEX station and have a suitable terminal or decoding software, listen on 518KHz. The transmissions are short, perhaps 5 to 10 minutes, repeated 4 hourly.



[NAVTEX](#) -- Loads of info by Cor van Soelen



AC6V's

Amateur Radio Links

[GO BACK TO THE BIG INDEX](#)

AC6V's

Amateur Radio Links

[GO BACK TO THE QUICK INDEX](#)



AC6V BRAG TAPE



Last Update: September 02, 2004

TELREX ANTENNA TRAP REPAIR -- FROM N6KI

Rod,

I just wrote up this Telrex antenna Trap repair procedure for Bob, K6XX. If you have room somewhere on your web page maybe you could include it somewhere so other Telrex owners around the world can keep em ticking!

73, Dennis N6K

Hi Bob, Yes Telrex traps do tend to toast but not since I modified the 15 and 20 mtr traps on the driven element of my 7 element Monarch which covers 40 thru 10 mtrs. Never had a problem with the 10 mtr traps. I marked where the driven elements assemblies were inserted into the short stub coming off the boom and was able with my tower cranked down and another person on my patio roof supporting and pushing up on the ends of the driven element, to remove the 2 sides. (I borrowed my neighbors pool cleaning poles and mounted a donut shaped piece of aluminum to the end of the pole and had my friend capture the end of the element so he could lift and take the weight off my end near the boom).

The failure mechanism is that even though the doorknob cap used in the trap is rated at 5 to 7 kV ACROSS the cap, Telrex, in their infinite wisdom, had laid the doorknob cap directly on top of and touching the coil section of the trap! So, the caps appear to flash right up through the SIDE of the cap from the coil! The object of this repair exercise is to remove the old burned out doorknob cap but replace it with 2 doorknobs in series, allowing you to lift the straps that the ends of the doorknob cap is attached to. Two advantages of this type of repair are:

- 1. You now have double the voltage protection across the two 5 kV doorknobs caps.**
- 2. The doorknob caps no longer lie directly on top of the trap coil. Now, on my Monarch, the value of the doorknob happened to be 33pF (Since they seem to burn one side of the driven element at a time, I was able to chisel off the goop on the corresponding good trap on the other side of the driven element and read the value, maybe yours are different value.) Ok so here's the drill on extracting the old burned doorknob and then resealing the trap. Once you get the element on the ground I went to a machinist (who happened to be my father) and he made me a small sharp chisel shaped piece of metal. I used it and a small ball peen hammer and I CAREFULLY chiseled off that brownish colored goop used to seal the the trap. I exposed the doorknob capacitor (or what was left of it) and I also exposed the flat metal straps on each side all the way down to and including the nut and screw end of the straps.**

Be very careful when chiseling around the coil not to dig the end of the chisel INTO the coil or flat

metal straps. If you do hit the coil by accident, although you won't cut through the coil you will nick it pretty good. Take a file to it later and file off any sharp edges or burrs you create. Using a small wire brush, be sure to remove ALL traces of the black burnt carbon and other debris that the burned out doorknob capacitor deposited in and around the coil.

You may need a small chisel tool to clean in between the coil windings. Since it's hard to find the exact 32.XX to 33.XX pF cap I replaced the original cap with 2 doorknob caps in series using a short piece of threaded rod to screw them together. (Changing the value of the combo of caps by just a few tenths of a pF moves the resonant point quite a bit. 0.5pF too much or too little could move you 150 kHz if I remember right!) I found plenty 50 to 75 pf 5 kV doorknob caps on the surplus market and put 2 caps in series of various values and was able to fine tune my antenna resonance points to exactly which part of the band I wanted. (This is NOT the fun part, as I started with some series combination value around 32.5 pF using my hand held capacitance meter, then, before sealing the traps, I reinstalled the driven element and cranked the tower up and measured resonant frequency.)

Changing the value of the combo of caps by just a few tenths of a pF moves the resonant point where I wanted it. I originally tried to use a grid dip meter to measure the resonant freq of the good corresponding trap on the opposite side of the driven element but that didn't work out for some reason (It's been a few years since I did the repair.) For some reason and maybe because I lifted the caps off of and away from the coil, my notes indicate that I wound up using combinations of caps that yielded capacitance in the 30 to 31.5 pF range, nowhere near the original 33 pF (marked value) they replaced!!

The opposite ends of the dual doorknob caps assembly are now connected to each strap and now it is easy to position the caps at least 1/4 inch away from the coil. Once you get the antenna resonant where you want it, seal the repair by first wrapping the coil from end to end with Kapton Tape which should be available from industrial electrical supply companies. I utilized a 1/2' width tape and applied 2 layers to the coil using an overlapping wrap. Then apply Dow Corning 738 Electrical Sealant to cover all exposed areas of the coil and doorknob capacitors. 738 is UV stable and has a dielectric property of 400 to 500 Volt per 0.001 inch. That will give you plenty of arc protection now that you have the caps 1/4" off the coil! (The sealant did NOT affect the resonant point, luckily!)

Unfortunately 738 only comes in white which makes for a very ugly repair, but up at 50 ft or more, who's going to see it except the birds! It also has only a 6 month shelf life so a lot of places won't stock it and you may have to special order it. There's an industrial supply company in San Diego called Yale Enterprises (619 299-7710) that used to sell it in 3 OZ small tubes but you may have to buy the caulking gun size. I believe that one 3 OZ tube will easily have enough sealant to redo 2 traps. The small tubes used to cost @ \$7 and @\$20 for the caulking gun size. There's also a place in San Jose area called Anderson Supply that carries it but may make you buy the larger amount to meet minimum order. Caveat Emptor if you use any other type of sealant, make sure it's UV impervious, temperature stable and has enough electrical dielectric strength, voltage wise.

Also, a different type of sealant might shift the resonant point !!! After you repair the burned trap,

go back and chisel out the remaining good trap doorknob and replace it or I can guarantee that in the dead of winter when your tower is covered with ice, the other side WILL fail. My Telrex Monarch continues to provide good reliable service, contest after contest on 40 thru 10 meters, pumping 1.5 kW into it for 48 hrs at a time! (I just found a note showing I repaired it 8 years ago!) If this 200 LB beam wasn't such a killer antenna on 40 mtrs with 3 almost full size elements, I probably would have not gone through this much trouble to repair it. BTW, it is was originally rated for 100 MPH wind and 5 KW and cost over \$2000 in 1982. So who says a trapped antenna can't compete!

73, Dennis Vernacchia N6KI / ZF2AR

AC6V's

Amateur Radio Links

[GO BACK TO THE BIG INDEX](#)

AC6V's

Amateur Radio Links

[GO BACK TO THE QUICK INDEX](#)



Last Update: July 31, 2002

AA3RL Transmission Line Calculator

Introduction:

There are a variety of programs available to the Radio Amateur that will calculate virtually every transmission line parameter that one may need. However, I have found the routines to be inconveniently scattered among many different programs. In addition, the programs usually require the data to be entered in serial form in order to obtain the calculated output. If another calculation is desired, all the data must be re-entered. As a result, I felt the need to create a spreadsheet style program where all input values are displayed and multiple "what-if" data changes may be implemented quickly with the click of the mouse.

Initially I used the spreadsheet to design Stub and Series Section Line Matches. Since then other utility functions were added that has enabled it to replace the Smith Chart, the pocket calculator, and the many computer programs for transmission line design applications. I hope you will find it equally useful.

Caution:

All formulas assume lossless transmission lines, but these results are usually within the measurement tolerance achievable by the amateur in normal situations. However, as line loss increases, i.e. with high SWR or long transmission line lengths, these approximations will diverge from the actual values. An excellent program to check the results for lossy lines is TLA, which is included with recent versions of the ARRL Antenna Book.

Format:

The spreadsheet is divided into convenient functional areas. Each area performs one of the calculations listed below. All sections share a common layout. The input data is grouped on the left side of the page, and the output data is grouped to its immediate right. Output values are shown in bold type. On the far right side of each section there are areas that are used for computational purposes, in order to break complex formulas into more manageable chunks. If these cells are disturbed or over-written the calculations may cease to function properly. I have learned from experience to keep a backup copy of the spreadsheet for when this eventually happens.

Contents:

The program performs the following calculations:

Length Conversion: Wavelength, Degrees, Feet

Series and Parallel Equivalent values

Capacitance and Inductance required for given reactance (X)

Air Wound Coil construction

Reactance and Length of Stubs

Stub Matching - Impedance (Z) over a 180 degree cycle along a lossless transmission line.

Impedance (Z) at any single point on a lossless transmission line (for stub matching)

Series Section Line Transformer (analytic solution) for impedance matching

Length Conversion: Wavelength, Degrees, Feet

In the screen shot below, we want to make a transmission line 1/8 (0.125) wavelength long, using 50 ohm line with a velocity factor of 0.78, and operating at a frequency of 7.0 MHz. This data is entered on the left side. The output indicates that the length should be 13.7 feet, which is 45 degrees. Alternatively, the reverse calculations may be performed.

| TLCalc1.xls | | | | | | | |
|--|---|--------|--------|--------------------|--------------|---|---|
| | A | B | C | D | E | F | G |
| 3 | AA3RL - TRANSMISSION LINE CALCULATOR | | | | | | |
| 4 | | | | | | | |
| 5 | Length Conversion: Wavelength, Degrees, Feet | | | | | | |
| 6 | | | | | | | |
| 7 | INPUT DATA: | | | OUTPUT DATA | | | |
| 8 | Wavelengths: | 0.125 | -----> | Length (Feet): | 13.70 | | |
| 9 | Freq (MHz.): | 7.000 | | Degrees: | 45.00 | | |
| 10 | Vel Factor: | 0.78 | | | | | |
| 11 | | | | | | | |
| 12 | Degrees: | 56.000 | -----> | Length (Feet): | 20.76 | | |
| 13 | Freq (MHz.): | 7.000 | | Wavelength: | 0.156 | | |
| 14 | Vel Factor: | 0.95 | | | | | |
| 15 | | | | | | | |
| 16 | Length (Feet): | 13.700 | -----> | Wavelength: | 0.12 | | |
| 17 | Freq (MHz.): | 7.000 | | Degrees: | 45.0 | | |
| 18 | Vel Factor: | 0.78 | | | | | |
| Sheet1 / Sheet2 / Sheet3 / Sheet4 / Sheet5 | | | | | | | |

Series and Parallel Equivalent values

Series and Parallel equivalent circuits are very useful for transmission line matching, as well as other circuit design applications. Conversions may be made in either direction.

| TLCalc1.xls | | | | | | | |
|--|---|---------|--------|--------------------------------|----------------|---|---|
| | A | B | C | D | E | F | G |
| 19 | | | | | | | |
| 20 | Series and Parallel Equivalents: | | | | | | |
| 21 | | | | | | | |
| 22 | INPUT DATA: | | | OUTPUT DATA | | | |
| 23 | Series Impedance Z (R +/- jX) | | | Parallel Equivalent (R +/- jX) | | | |
| 24 | R(s) | 77.50 | -----> | R(p) | 134.39 | | |
| 25 | X(s) | -66.40 | -----> | X(p) | -156.86 | | |
| 26 | | | | | | | |
| 27 | Parallel Impedance Z (R +/- jX) | | | Series Equivalent (R +/- jX) | | | |
| 28 | R(p) | 425.00 | -----> | R(s) | 25.00 | | |
| 29 | X(p) | -106.25 | -----> | X(s) | -100.00 | | |
| Sheet1 / Sheet2 / Sheet3 / Sheet4 / Sheet5 | | | | | | | |

Capacitance and Inductance required for given reactance (X)

At any given frequency, input the desired inductive reactance (+X) or capacitive reactance (-X). The spreadsheet calculates the required inductance (uH.) or capacitance (uF and pF).

| | | | | |
|----|--|------------|--------------------|-----------------|
| 32 | | | | |
| 33 | Capacitance and Inductance required for Reactance = X | | | |
| 34 | | | | |
| 35 | INPUT DATA: | | OUTPUT DATA | |
| 36 | Freq (MHz.): | 3.50 | | |
| 37 | | | | |
| 38 | Reactance, Ind (+X) | 800 -----> | Induct (uH) | 36.38 |
| 39 | | | | |
| 40 | Reactance, Cap (-X) | 500 -----> | Capac (uF) | 0.000091 |
| 41 | | | Capac (pF) | 91 |
| 42 | | | | |

Reactance and Length of Stubs

Another way to obtain a desired reactance is with the use of transmission line stubs. Input the desired inductive reactance (+X) or capacitive reactance (-X). The spreadsheet calculates the required length of stub: open for -X, shorted for +X.

Alternatively, given a stub of any length in feet which is less than $\frac{1}{4}$ wavelength, the reactance will be calculated. Results may not be accurate if the electrical length is greater than 90 degrees.

| | | | | | | | | | | |
|--|---|--------|--------------|--------------------|---------------|-------------|---|---|---|--|
| TLCalc1.xls | | | | | | | | | | |
| | A | B | C | D | E | F | G | H | I | |
| 31 | | | | | | | | | | |
| 32 | Reactance of Transmission Line Stubs | | | | | | | | | |
| 33 | *** Length MUST be less than 1/4 wavelength (90 degrees) to be accurate | | | | | | | | | |
| 34 | | | | | | | | | | |
| 35 | INPUT DATA: | | | OUTPUT DATA | | | | | | |
| 36 | | | | | | | | | | |
| 37 | Stub Data: | | | Reactance: | | | | | | |
| 38 | Stub Length (Feet): | 13.700 | -----> | X (open) | -50.00 | | | | | |
| 39 | | | -----> | X (shorted) | 50.00 | | | | | |
| 40 | Freq (MHz.): | 7.000 | | Length (Deg) | 45.00 | | | | | <i>Result NOT accurate if Length > 90 deg</i> |
| 41 | Vel Factor: | 0.78 | | | | | | | | |
| 42 | Z (line), resistance: | 50 | | | | | | | | |
| 43 | | | | | | | | | | |
| 44 | Desired Reactance: | | Stub Needed: | Degrees | Feet | | | | | |
| 45 | Capacitive Reac (-X) | 34 | -----> | Length (open) | 55.8 | 5.66 | | | | |
| 46 | Inductive Reac (+X) | 34 | -----> | Length (shorted) | 34.2 | 3.47 | | | | |
| 47 | Freq (MHz.): | 21.000 | | | | | | | | |
| 48 | Vel Factor: | 0.78 | | | | | | | | |
| 49 | Z (line), resistance: | 50 | | | | | | | | |
| 50 | | | | | | | | | | |
| 51 | | | | | | | | | | |
| Sheet1 / Sheet2 / Sheet3 / Sheet4 / Sheet5 / Sheet6 / Sheet7 | | | | | | | | | | |

Stub Matching

Using tuning stubs to match an antenna and transmission line is quite popular and useful. While the theory of stub matching is beyond the scope of this article, the following example illustrates how it may be performed using the AA3RL TLCalc spreadsheet.

We wish to match a 50 ohm feedline to an antenna with $Z = 61 + j80$. These values are entered as inputs. We immediately notice that the SWR is 3.88. Next, scan the third Column of the OUTPUT DATA to find where the parallel equivalent resistance, $R(p)$, approaches 50 ohms. We see that this occurs somewhere between 80 and 90 degrees. A good initial guess would be 85 degrees. We also note that $R(p)$ is not changing too quickly at this point so that measuring the stub insertion point will not be overly critical.

| TlCalc1.xls | | | | | | | | | | |
|-------------|---|----|---|--------------------|-----------------------------|-------|------------------------------|----------------|--------|---------|
| | A | B | C | D | E | F | G | H | I | J |
| 66 | Impedance (Z), over a 180 degree cycle, along a Lossless Transmission Line: | | | | | | | | | |
| 67 | | | | | | | | | | |
| 68 | INPUT DATA: | | | OUTPUT DATA | | | | Comp In | | |
| 69 | Ant/Load Z (R +/- jX) | | | | | | | A(swr) | | |
| 70 | R(L) | 61 | | SWR: | 3.88 | | B(swr) | | | |
| 71 | X(L) | 80 | | | | | | | | |
| 72 | Line Zo (R only) | 50 | | | | | | | | |
| 73 | | | | | | | | | | |
| 74 | OUTPUT DATA | | | | Parallel Equivalents | | Computational Informa | | | |
| 75 | Length of Line (deg) | | | Line Z (R) | Line Z (X) | R(p) | X(p) | Len (rad) | R num | R/X den |
| 76 | 0 | | | 61.0 | 80.0 | 165.9 | 126.5 | 0 | 61 | 1 |
| 77 | 10 | | | 112.0 | 90.2 | 184.6 | 229.3 | 0.174533 | 62.897 | 0.56162 |
| 78 | 20 | | | 185.9 | 37.5 | 193.5 | 959.7 | 0.349066 | 69.081 | 0.3716 |
| 79 | 30 | | | 162.0 | -69.1 | 191.5 | -449.2 | 0.523599 | 81.333 | 0.50195 |
| 80 | 40 | | | 89.2 | -89.4 | 178.9 | -178.4 | 0.698132 | 103.95 | 1.16531 |
| 81 | 50 | | | 50.3 | -73.3 | 157.2 | -107.8 | 0.872665 | 147.64 | 2.93624 |
| 82 | 60 | | | 32.1 | -55.8 | 129.0 | -74.2 | 1.047198 | 244 | 7.60264 |
| 83 | 70 | | | 22.9 | -41.4 | 97.7 | -54.1 | 1.22173 | 521.47 | 22.768 |
| 84 | 80 | | | 17.9 | -29.7 | 67.2 | -40.5 | 1.396263 | 2023 | 113.062 |
| 85 | 90 | | | 15.1 | -19.8 | 41.0 | -31.3 | 1.570796 | 2E+34 | 1.1E+33 |
| 86 | 100 | | | 13.5 | -10.9 | 22.3 | -27.7 | 1.745329 | 2023 | 149.359 |
| 87 | 120 | | | 13.1 | 5.6 | 15.4 | 36.2 | 2.094395 | 244 | 18.6878 |
| 88 | 130 | | | 14.0 | 14.0 | 28.0 | 28.0 | 2.268928 | 147.64 | 10.5635 |
| 89 | 140 | | | 15.9 | 23.2 | 49.7 | 34.1 | 2.443461 | 103.95 | 6.53555 |
| 90 | 150 | | | 19.4 | 33.7 | 77.9 | 44.8 | 2.617994 | 81.333 | 4.19699 |
| 91 | 160 | | | 25.6 | 46.2 | 109.2 | 60.4 | 2.792527 | 69.081 | 2.70101 |
| 92 | 170 | | | 37.2 | 61.8 | 139.7 | 84.2 | 2.96706 | 62.897 | 1.69012 |
| 93 | 180 | | | 61.0 | 80.0 | 165.9 | 126.5 | 3.141593 | 61 | 1 |
| 94 | | | | | | | | | | |
| 95 | <i>* Caution: Valid only for lossless lines. For lossy lines (high SWR or long lengths), validate output data with TLA</i> | | | | | | | | | |
| 96 | | | | | | | | | | |

Next move to the spreadsheet section for computing the impedance at a **single point** along a transmission line. Enter the same

inputs: $Z = 61 + j80$, Frequency = 21 MHz., TL = 50 ohms, velocity factor 0.78. Start with the guess of 85 degree length. Adjust this value until you obtain a parallel equivalent $R(p) = 50$ ohms. This turns out to be 86 degrees, which at 21 MHz and vf 0.78 equals 8.73 feet. Thus the stub is inserted 8.73 feet from the antenna. The stub (or discrete component) must provide +34.44 ohms (inductive) reactance in order to cancel the - 34 ohms parallel equivalent (capacitive) reactance at the stub insertion point. This can be accomplished with a 3.74 foot shorted stub as shown above.

| | A | B | C | D | E | F | G | H |
|----|---|-------|--------|-------------------------|--------------|-----------------------|---------------|---|
| 52 | | | | | | | | |
| 53 | Impedance (Z) at any Single Point along a Lossless Transmission Line: | | | | | | | |
| 54 | | | | | | | | |
| 55 | INPUT DATA: | | | OUTPUT DATA | | | | |
| 56 | Ant/Load Z (R +/- jX) | | | Line/Input Z (R +/- jX) | | Parallel Equivalent Z | | |
| 57 | R(L) | 61.00 | -----> | R(in) | 16.0 | R(in/p) | 50.72 | |
| 58 | X(L) | 80.00 | | X(in) | -23.6 | X(in/p) | -34.44 | |
| 59 | Length of Line (deg) | 86 | | | | | | |
| 60 | Freq (MHz.): | 21 | | SWR: | 3.88 | | | |
| 61 | Vel Factor: | 0.78 | | Length (Feet): | 8.73 | | | |
| 62 | Line Zo (R only) | 50 | | | | | | |
| 63 | | | | | | | | |
| 64 | * Caution: Valid only for lossless lines. For lossy lines (high SWR or long lengths), validate output. | | | | | | | |
| 65 | | | | | | | | |

Series Section Line Transformer (analytic solution) for impedance matching

While the theory of Series Section Line Transformer matching is beyond the scope of this article, the solution provided is analytic and straightforward. The same example used above for stub matching illustrates how it may be performed using a SSLT. In this case we elect to use 450 ohm ladder line with a vf = 0.95 for the matching section. The output indicates that a 0.96 foot length of ladder line should be inserted 5.03 feet from the antenna.

| | A | B | C | D | E | F | G |
|-----|--|--------|---|--|----------------|-------------|---|
| 96 | | | | | | | |
| 97 | Impedance Matching with a Series Section Line Transformer | | | | | | |
| 98 | | | | | | | |
| 99 | INPUT DATA: | | | OUTPUT DATA | | | |
| 100 | Ant/Load Z (R +/- jX) | | | | | | |
| 101 | R(L) | 61.00 | | | | | |
| 102 | X(L) | 80.00 | | | | | |
| 103 | | | | | Degrees | Feet | |
| 104 | Primary Line | -----> | | Length 1: | 49.6 | 5.03 | |
| 105 | Z ₀ = | 50 | | L1 = First length (from antenna) of Z ₀ line | | | |
| 106 | Vel Factor | 0.78 | | | | | |
| 107 | | | | | | | |
| 108 | Matching Line | -----> | | Length 2 | 9.5 | 0.96 | |
| 109 | Z ₁ = | 450.0 | | L2 = Second length (from antenna) of Z ₁ line | | | |
| 110 | Vel Factor | 0.78 | | | | | |
| 111 | | | | | | | |
| 112 | Operating | | | L3 = Any Length from L2 to Source | | | |
| 113 | Freq, MHz. | 21.000 | | | | | |
| 114 | | | | | | | |
| 115 | | | | | | | |

Download:

The spreadsheet was created in Microsoft Excel 7.0 format, with the filename TLCalc1.xls. It has been zipped for storage and downloading. If it is updated in any significant way, the next version will be named "TLCalc2".

- [Click here to download the AA3RL Transmission Line Calculator.](#)

(TLCalc1.xls). Excel 7.0 spreadsheet format, (~10K zip file).

This page is published by Mike Banz, AA3RL as a service to the Amateur Radio community.
Please distribute freely.

The author welcomes any questions, criticisms, or compliments via email.



[email Mike with comments or questions.](#)

Setting up shop

Some of the interesting shots of the W5AJ Rohn 25G tower

This installation is taking place in 2003.

And the gasoline driven digger was low cost compared to what it would have cost in time to recover.....



This is shot of project start.

Gasoline powered. Less pain then posthole diggers in WTX soil



AJ plate on Left Rohn plate is on the right



just south of the Crank up tower (see tower #1 page) Tower sections moved to location.



Hinged base. 1st ten feet in place

Concrete on base & guy posts was hand mixed 5000psi premix from hardware store. the 5000# version would setup to something like 2400psi strength in 3 days.



After getting ten feet up the section is laid over and another 20 feet added.



Setting the lower guys.



Bigger saw horse being put into place



Add another 30 feet & now 60 feet done - is ten open ?

note date on picture (I think 26th was highest SFI for the eleven year cycle)



Assembly of A4 with 40 meter kit.

that is a WTX Apple tree behind the A4



From the hinged end

20 feet of 25G on ground to right.

Note antenna assembly platform (some think this a trampoline)



Early Saturday morning SS SSB 2003

With the help of my wife the 20 foot tower for lift cable is raised

and everything is in place for a lift shortly after 8 am

had planned this to be one person setup but had a guywire problem on the 20 foot tower.

tnx to the wife for bailing me out on that one.

there's another story there about always carrying a cell phone



The lift begins as the tower comes off the sawhorse

Stopped at this point to double check lift cable





Almost vertical - note bird already checking out the A4

The manual (no computer) calculations showed at this point the tower could be hand pulled

vertical

Wasn't a cake walk either



Taken just before sunrise Monday morning after SS SSB weekend

small print - this is not a design page - this shows the installation of a rohn 25G using a hinge plate similar to Rohn's. Hours of calculations were done to match conditions, tower & equipment and insure nothing was over stressed.



Work going on inside the shack building upper shelf



in the background sound you are listening to a QSO with cv5h
that is used in the UBN study by W5AJ

[W5AJ HOME PAGE](#)

[TOP 50](#)

This page added 2003 Nov & is developing as time permits note not all pictures and text maybe
uploaded

This page maintained by W5AJ

**Please send your comments and suggestions to rwood90
#on# direcway.com**

104060

ServuStats

NYLO'S NOTEPAD

Homebrew projects for radio & electronics enthusiasts

- TOWER PAGE -

[back to HOME page](#)



There is a huge amount of relevant information you should know before building a tower. Here's a collection of information that I have gathered that will give you a boost. You'll be glad you took the time:

[N1LO's GUYED TOWER TOPIC SUMMARY](#)

To find out more about how towers react to windloads and why it is so important to select guy materials and sizes for low stretch as well as adequate ultimate breaking strength:

[Guyed Tower Safety Analyses by Kurt, K7NV](#)

OK, that's a lot of heavy reading so far.... Check out some of these photos and illustrations:

[N1LO'S TOWER PICTURE GALLERY](#)

[PAGE 1](#)

[PAGE 2](#)

[PAGE 3](#)

Have you found something useful here? Got a comment? Drop me a line: n1lo (remove 'nosspam' from address when sending)

You are visitor number  since 12/21/99

KO4BB's Tower Building Project



Last Updated:

NOTE: This is a description of how I built my tower. It is provided in the hope that it will be useful but without any warranty of any kind. Make sure to get the necessary permits for your area, if applicable and if you have any doubt, talk to a professional civil engineer even if not required by local regulations.

Even though a permit was not required in my county and subdivision (not required for ham towers under 75'), I thought about getting one for the piece of mind. However, in my county, the tower and antennas would have to be rated 140 mph to get a permit, something few ham radio budgets can afford, and something unnecessary in my case since the tower folds. Further, I had access to persons knowledgeable about building codes and permits and the final design takes into consideration the advice I got informally from these qualified individuals. While this is not as good as "money in the bank", or a building plan certified by a professional engineer, I felt it was sufficient for my purpose. Your mileage may vary.

If you intend on using information on these pages to build a permanent (non-folding) tower, make sure you understand the differences and protect yourself accordingly, both from safety and legal standpoints.

Pictures: [taken during construction](#), [the finished tower and antennas](#).

Useful tower building resources:

- [N1LO](#)'s home page contains a tremendous amount of information on tower building and anything related.
- [K7NV](#)'s page on wind load calculations (this page has not proven to be reliably available, so you may want to check the links below).

Here is a link to his [YagiStress](#) software ([download the demo version](#)).

- [WB6WUW](#)'s very informative page, which was featured in July 2003 QST.

This page would not be complete without the deepest thanks and appreciation for the members of the [Playground Amateur Radio Club PARC, W4ZBB](#) who came in droves to help with the tower raising party.

My Tower Project

I bought this folding Rohn 25 tower used from a local ham who had it attached to the side of his house. For extra safety (we are on the Florida coast, and we do have hurricanes and strong winds), he also had installed guy wires.

The guy wires were going from just below the hinge to the top of 7' high, 3" diameter schedule 40 steel pipes instead of directly to the ground because there was not much room where his tower was located and the guy wires would have been too steep to be effective.

I thought this would be a neat idea to reduce the risk of someone (like a kid) running into the guy wires. With the normal mounting scheme, guy wires leave the ground around 45 degree angle and that means that shrubs or a fence have to be installed to prevent accidents, and I certainly did not want to loose that much real estate. I also wanted to put the tower as close to the fence as possible. With the guy posts, I loose much less real estate and the guy wires take off from the tower closer to horizontal by about 15 degrees, so they should do a good job. The guy posts are at about 25 feet from the base of the tower.

So I did the same thing, except that in my case, the tower is detached from the house and squarely in the middle of my backyard.

To stiffen the guy posts, another EHS guy cable runs from the top of the guy post to a J bolt about 1.5' from the base of the post. This does little for ultimate strength but does stiffen the pipes and reduces flexing in the wind.

The pipes are also filled with concrete all the way to the top to make sure they do not collapse under extreme stress. The concrete makes them stronger and prevents moisture and water from getting inside the pipe and causing corrosion. The concrete also dampens the tubes, so they don't sing like a bell when something hits them.

Because it is a folding tower (it folds approximately in the middle, a design no longer offered by Rohn unfortunately), there are 4 guy wires instead of the usual 3 so that the fulcrum that allows to fold and raise up the tower has clearance.

Note: I read that Rohn stopped making the folding type tower because hams were overloading them and having problems. The tower is certainly very vulnerable when it is being cranked up and down, particularly when it is at a 90 degree angle. I wanted to take it down during moderate winds at one time, and the effect of the wind on the structure when the tower is folded is significant. You do not want to leave it like that very long. However, when the tower is straight up and properly rigged, it is as strong as a normal Rohn 25 tower.

The guy posts are actually 12' long 3" diameter schedule 40 steel pipes (structural grade, not just "pipe") with 5' in the ground, in concrete. The guy post holes are therefore 5'6" deep, and 1.5' x 2.5' and filled with 3000 lbs rated strength, fiberglass reinforced concrete. The post base also holds the J bolt for the post guy. Place a brick at the bottom of the hole so the post is at least 3" off the dirt. I poured concrete up to about 3" under the ground surface, so that if and when I move out of the house, I just have to cut the pipes flush with the concrete and cover the hole with dirt and grass.

The tower concrete base also is filled with 3000 lbs rated, fiberglass reinforced concrete. I selected the fiberglass reinforcement because the tower base is bolted down in the concrete using 4 J bolts, instead of just burying a tower element as I have seen it done often. The fiberglass gives the concrete an extra measure of strength around the J bolts and only adds about \$5.00 per cubic yard to the cost of the concrete. In total, I used 5 cubic yards of concrete, in addition to what I used to fill the posts (I used regular Quikrete for that). 5 yards was the minimum quantity for which there was no delivery charge from all the vendors in the area.

Please note that fiberglass reinforcement does not allow to get rid of the rebar cage unfortunately.

To make sure the concrete hardens and does not just dry, keep it covered from the sun and keep it moist. I used an old piece of carpet laid over the concrete pad, and covered with a large piece of cardboard. I waited until the next day in the morning, when the concrete surface was already somewhat hard. Then twice a day I would hose the carpet and cover it with the cardboard so it did not dry too quickly. I took carpet and cardboard off after about 4 days of that regiment. The concrete looks pretty hard to me. I pounded on it with a hammer and could not chip it.

I let the concrete cure for two weeks before putting up the tower. The concrete was plenty hard enough by then and we had absolutely no problem, even though it was

interesting when two of us were hooked up to the tower at about 20' up in the air before we had the guy wires attached (please note we had rope guys for safety while we were doing that, but these don't do much to stabilize the tower to the point I felt I needed for peace of mind.)

Go to [pictures](#)

Return to [KO4BB's Ham Radio Page.](#)

Copyright (c) 2003-2004 [KO4BB](#)

Last Updated:



N9XT, I am a Life member of the ARRL, I have been licensed since 1977 and have worked 190 Countries (I just worked 3D2CY Conway Reef) 1st DX contact in 18 years. My other Passion is UHF and Control Systems.

Life Member

The TH7DX antenna is up! Scroll down to see pictures. See you on the airways!

Anyone with a Website, particularly if you have projects or DX Pediton photos that would like a link please contact me.



**The American
Radio Relay
League**

**Updated
12/25/2003**

[Celebrity Hams](#)

| |
|-------------------|
| Home |
| Nascar |
| Desert Fun |
| Amateur Radio |
| Celebrity Hams |
| My BBQ |
| Genealogy |
| Recipes n Tips |
| Science_Invention |
| Beverages |



[AC6V has the most active Links](#)

[ARRL](#)

[Radio Anomalies](#)

[QRZ](#)

[Extra Class Question Pool](#)

[Radio Frequency Spectrum](#)

[W4RNL](#)

[101 Science](#)

I took this picture from Mt Soledad in San Diego in November of 1971. The strike hit a sub station and blacked out an entire area of town.

[Many Local Links, courtesy of AC6V](#)

[Find a store, Amateur activities, Repeater lists and more!](#)



You need a level, elevated, surface to assemble this antenna. This is how I did mine.



I used a Carpenters bubble level with a riser block on each side to verify that all elements were in plane. (Level not shown)



I made this pulley to support the mid section while raising the assembly.



The top of the tower is fitted with this larger pulley.



You can see how this works. There is a double pulley (2 grooves side by side) on the roof.



The other end of the ropes is attached to the Blazer. The rope is a loop as you can see by the previous photo.



We used an extension ladder at the right height to support the tower and keep the antenna off the ground. The ladder is lashed to the tower and follows the tower as it is raised to this point.



Art, K6XT does all the finishing touches to the assembly, here he is RTVing the Balun to weather proof it.



We are read to raise the Tower assembly, we think!



The Assembly is about 45 degrees up at this point.



The Assembly is almost vertical now. Damon is getting ready to nest the tower into a roof eave bracket we made to hold it in place.



First contact 3D2CY Conway Reef!

Coming soon, an interactive calculator to determine the force required to upright your tower and antenna.
I'm looking for assistance to do this.

This is intended as a guide only. The Web Master (N9XT) is not responsible for accidents that may occur through miscalculations, faulty gear or poor procedures.



This is it, The vintage is mid 70's Drake and Alpha. Some day we may upgrade to the state of the art stuff. But you know what, they answer every time I call so what's the point? N9XT

[N9XT has more at this site!](#)





[Home Page](#)

[Company Profile](#)

[Manufacturing](#)

[Distributors](#)

[Request for Bid](#)

[Lattice Towers](#)

[Tubular Towers](#)

[Mobile Tower Units](#)

[Feedback](#)

[Catalog Request](#)

[Accessories](#)

[EMAIL](#)

US Tower Corporation

*Manufacturer of the World's Finest,
State of the Art,
Steel Telescoping Towers*

Now with 2 locations to better serve our clients:

Headquarters:

1220 N. Marcin St. ~ Visalia, CA 93291
Phone: (559) 733-2438 ~ Fax: (559) 733-7194

and our newest location:

702 E. North St.
Lincoln, KS 67455
Phone: (785) 524-9966 ~ Fax: (785) 524-9908



Now with 2 locations to

better serve our clients:

Headquarters:

1220 N. Marcin St.
Visalia, CA 93291
Phone: (559) 733-2438
Fax: (559) 733-7194

and our newest location:

702 E. North St.
Lincoln, KS 67455
Phone: (785) 524-9966
Fax: (785) 524-9908

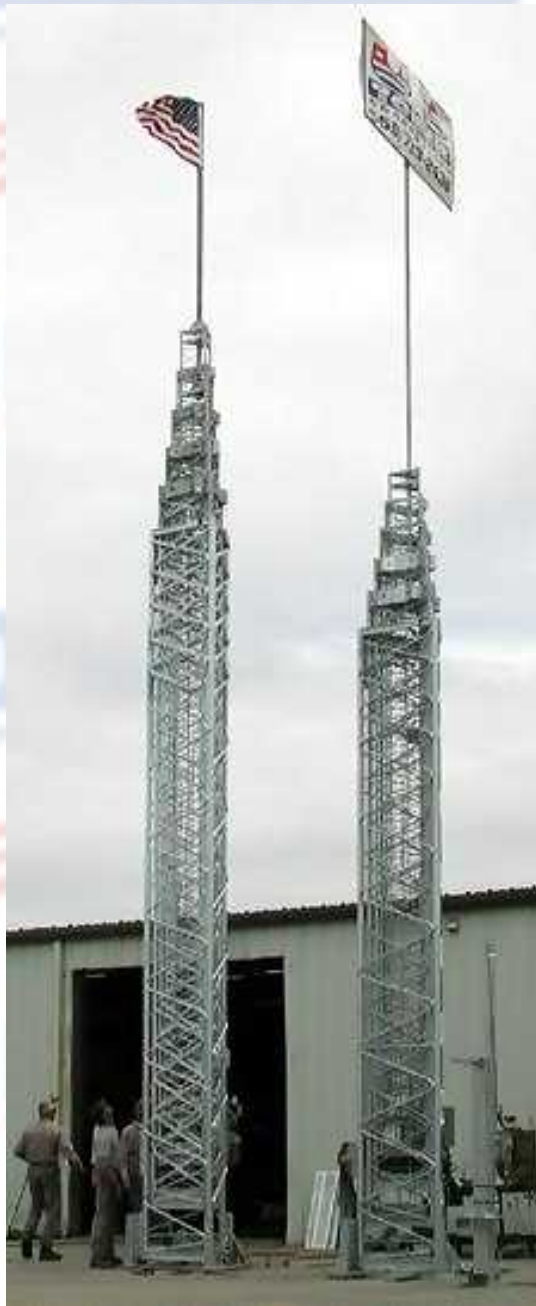



[Company Profile](#) | [Manufacturing](#) | [Distributors](#) | [Contact Form](#) | [Lattice Style Towers](#)
| [Tubular Towers](#) | [Mobile Tower Units](#) | [Feedback](#) | [Catalog Request](#) |
[Accessories](#)



This website, all graphics, photos and contents © US Tower Corp. 2002, 2003



- Publications
- Towers
- Rigging Gear
- Safety Equipment
- Weatherproofing
- Tower Installations
- Steel Masts
- Miscellaneous
- Tech Notes
- How to Order
- Contact Us
- Home Page

CHAMPION RADIO PRODUCTS

Welcome to Champion Radio Products!

**Champion Radio Products is your source for
Trylon radio towers, tower safety equipment,
rigging gear, antenna reports, and more.**

 [View Cart](#)

1508 19

© Champion Radio Products - All Rights Reserved. Webmaster: ka9fox@qth.com



Publications
Towers
Rigging Gear
Safety Equipment
Weatherproofing
Tower Installations
Steel Masts
Miscellaneous
Tech Notes
How to Order
Contact Us
Home Page

 **View Cart**

Tech Notes

[County Listings of Minimum Wind Speeds](#)

Useful for planning your next tower!

["Ten Most Common Tower Building Mistakes"](#)

The popular and valuable guide, the "Ten Most Common Tower Building Mistakes". Over 500 of these have been mailed out over the last two years and now it's available here.

[View Cart](#) | [How to Order](#) | [Contact Us](#) | [Home Page](#)
[Publications](#) | [Towers](#) | [Rigging Gear](#) | [Safety Equipment](#)
[Weatherproofing](#) | [Tower Installation](#) | [Steel Masts](#) | [Tech Notes](#) | [Misc.](#)

© 1998 Champion Radio Products, All Rights Reserved.

Web Site by [KA9FOX](#) of [Internet Solutions](#) and hosted by [QTH.COM](#)



Publications
Towers
Rigging Gear
Safety Equipment
Weatherproofing
Tower Installations
Steel Masts
Miscellaneous
Tech Notes
How to Order
Contact Us
Home Page

 **View Cart**

Software

MARC SOFTWARE

Champion Radio Products is the exclusive dealer for MARC - the Mast, Antenna and Rotator Calculator. It will automatically calculate the mast bending moment of any antenna system. Put in the wind speed, select the antenna info from the antenna table, add the spacing -- MARC does the rest. It'll give you the mast bending moment and tell you what yield strength and wall thickness of mast is required. It'll even recommend suitable rotators for the installation. For PC. Requires DOS 2.0 or above or Windows and comes on 1.4 Mb diskette. **Only \$10.00**

QUANTITY TO ORDER:

[View Cart](#) | [How to Order](#) | [Contact Us](#) | [Home Page](#)
[Publications](#) | [Towers](#) | [Rigging Gear](#) | [Safety Equipment](#)
[Weatherproofing](#) | [Software](#) | [Steel Masts](#) | [Tech Notes](#) | [Misc.](#)

© 1998 Champion Radio Products, All Rights Reserved.

Web Site by [KA9FOX](#) of [Internet Solutions](#) and hosted by [QTH.COM](#)

[Order this information in Print](#)[Order this information on CD-ROM](#)[Download in PDF Format](#)[Click here to make tpub.com your Home](#)

Page Title: Special Antennas

[tpub.com Updates](#)[Page](#)[Back](#) | [Up](#) | [Next](#)

Web

www.tpub.com

[Back](#)[Up](#)[Next](#)

Multielement Parasitic Array Content Moved Rhombic antennas

[[Back](#)] [[Home](#)] [[Up](#)] [[Next](#)]

SPECIAL ANTENNAS

In this section we will cover some special communications and radar antennas. Some of these antennas we touch on briefly since they are covered thoroughly in other courses.

Previously discussed antennas operate with standing waves of current and voltage along the wires. This section deals principally with antenna systems in which the current is practically uniform in all parts of the antenna. In its basic form, such an antenna consists of a single wire grounded at the far end through a resistor. The resistor has a value equal to the characteristic impedance of the antenna. This termination, just as in the case of an ordinary transmission line, eliminates standing waves. The current, therefore, decreases uniformly along the wire as the terminated end is approached. This decrease is caused by the loss of energy through radiation. The energy remaining at the end of the antenna is dissipated in the terminating resistor. For such an antenna to be a good radiator, its length must be fairly long. Also, the wire must not be too close to the ground. The return path through the ground will cause cancellation of the radiation. If the wire is sufficiently long, it will be practically nonresonant over a wide range of operating frequencies.

LONG-WIRE ANTENNA

A LONG-WIRE ANTENNA is an antenna that is a wavelength or longer at the operating frequency. In general, the gain achieved with long-wire antennas is not as great as the gain obtained from the multielement arrays studied in the previous section. But the long-wire antenna has advantages of its own. The construction of long-wire antennas is simple, both electrically and mechanically, with no particularly critical dimensions or adjustments. The long-wire antenna will work well and give satisfactory gain and directivity over a frequency range up to twice the value for which it was cut. In addition, it will accept power and radiate it efficiently on any frequency for which its overall length is not less than approximately 1/2 wavelength.

Another factor is that long-wire antennas have directional patterns that are sharp in both the horizontal and vertical planes. Also, they tend to concentrate the radiation at the low vertical angles. Another type of long-wire antenna is the BEVERAGE ANTENNA, also called a WAVE ANTENNA. It is a horizontal, long-wire antenna designed especially for the reception and transmission of low-frequency, vertically polarized ground waves. It consists of a single wire, two or more wavelengths long, supported 3 to 6 meters above the ground, and terminated in its characteristic impedance, as shown in figure 4-34.

Figure 4-34. - Beverage antenna.

Home

Information Categories

- [Administration](#)
- [Advancement](#)
- [Aerographer](#)
- [Automotive](#)
- [Aviation](#)
- [Combat](#)
- [Construction](#)
- [Diving **New**](#)
- [Draftsman](#)
- [Engineering](#)
- [Electronics **New**](#)
- [Food and Cooking **New**](#)
- [Math](#)
- [Medical](#)
- [Music](#)
- [Nuclear Fundamentals](#)
- [Photography](#)
- [Religion](#)
- [USMC](#)

Products

- [Educational CD-ROM's](#)
- [Printed Manuals](#)
- [Downloadable Books](#)

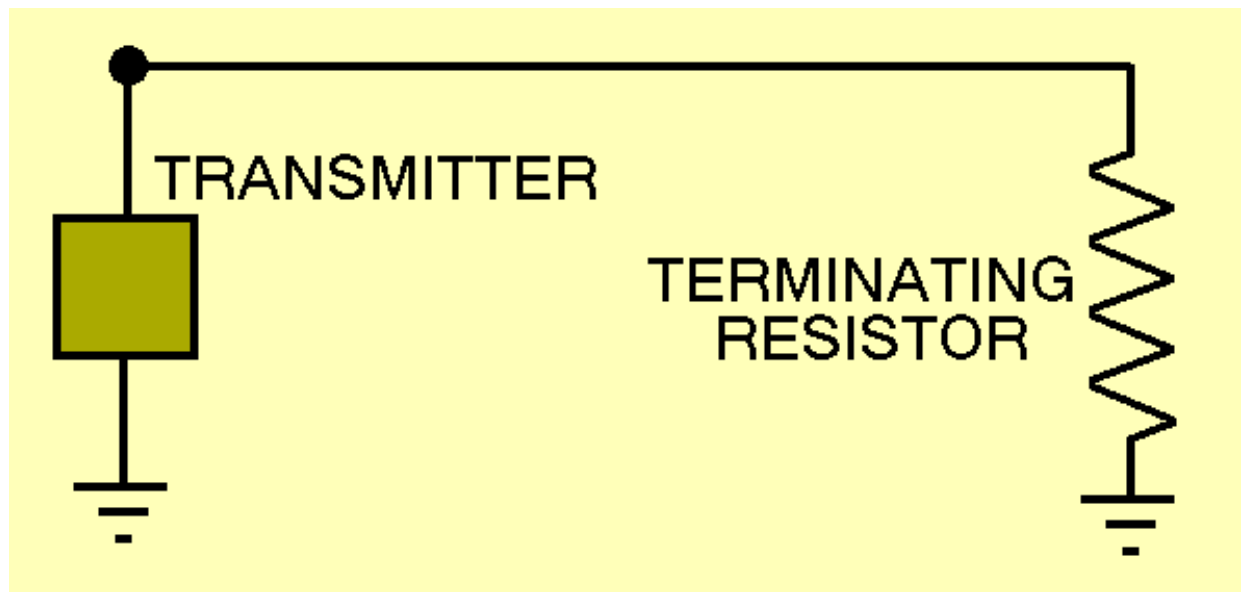

Q.44 To radiate power efficiently, a long-wire antenna must have what minimum overall length? **Answer**

Q.45 What is another name for the Beverage antenna? **Answer**

V ANTENNA

A V ANTENNA is a bidirectional antenna used widely in military and commercial communications. It consists of two conductors arranged to form a V. Each conductor is fed with currents of opposite polarity.

The V is formed at such an angle that the main lobes reinforce along the line bisecting the V and make a very effective directional antenna (see figure 4-35). Connecting the two-wire feed line to the apex of the V and exciting the two sides of the V 180 degrees out of phase cause the lobes to add along the line of the bisector and to cancel in other directions, as shown in figure 4-36. The lobes are designated 1, 2, 3, and 4 on leg AA', and 5, 6, 7, and 8 on leg BB'. When the proper angle between AA' and BB' is chosen, lobes 1 and 4 have the same direction and combine with lobes 7 and 6, respectively. This combination of two major lobes from each leg results in the formation of two stronger lobes, which lie along an imaginary line bisecting the enclosed angle. Lobes 2, 3, 5, and 8 tend to cancel each other, as do the smaller lobes, which are approximately at right angles to the wire legs of the V. The resultant waveform pattern is shown at the right of the V antenna in figure 4-36.

Figure 4-35. - Basic V antenna.

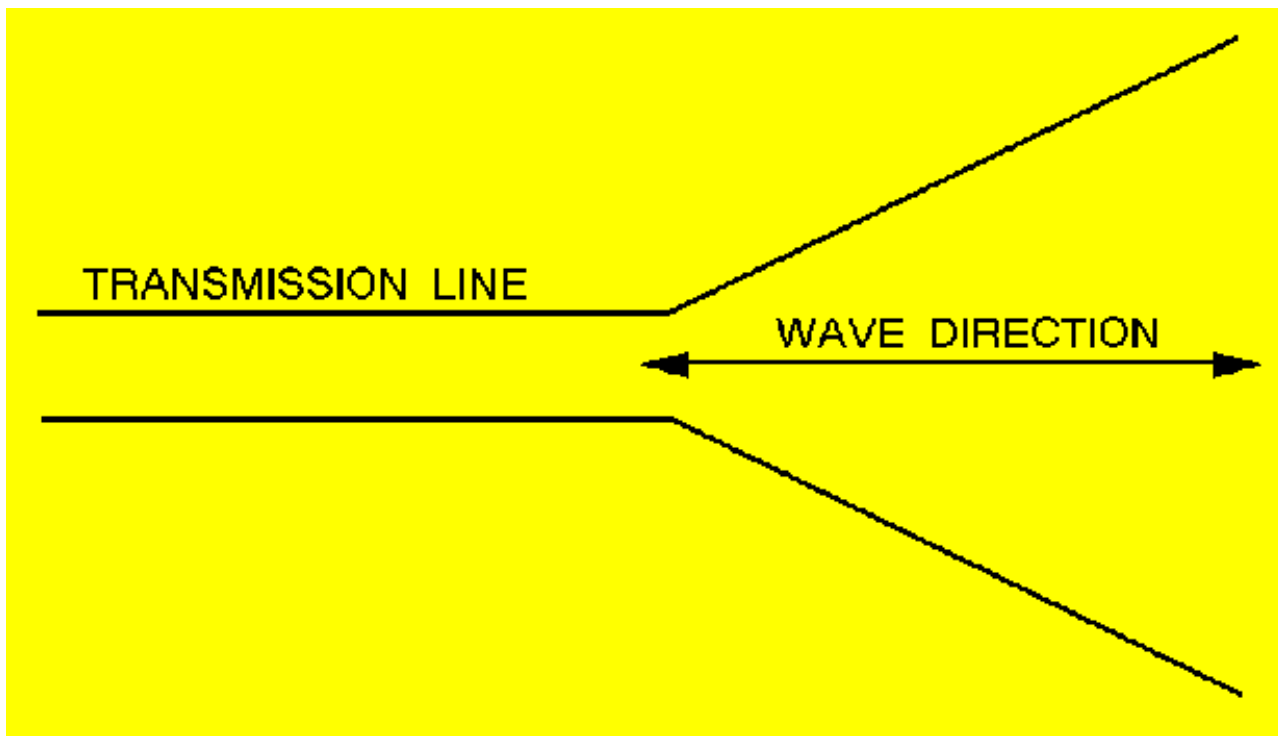
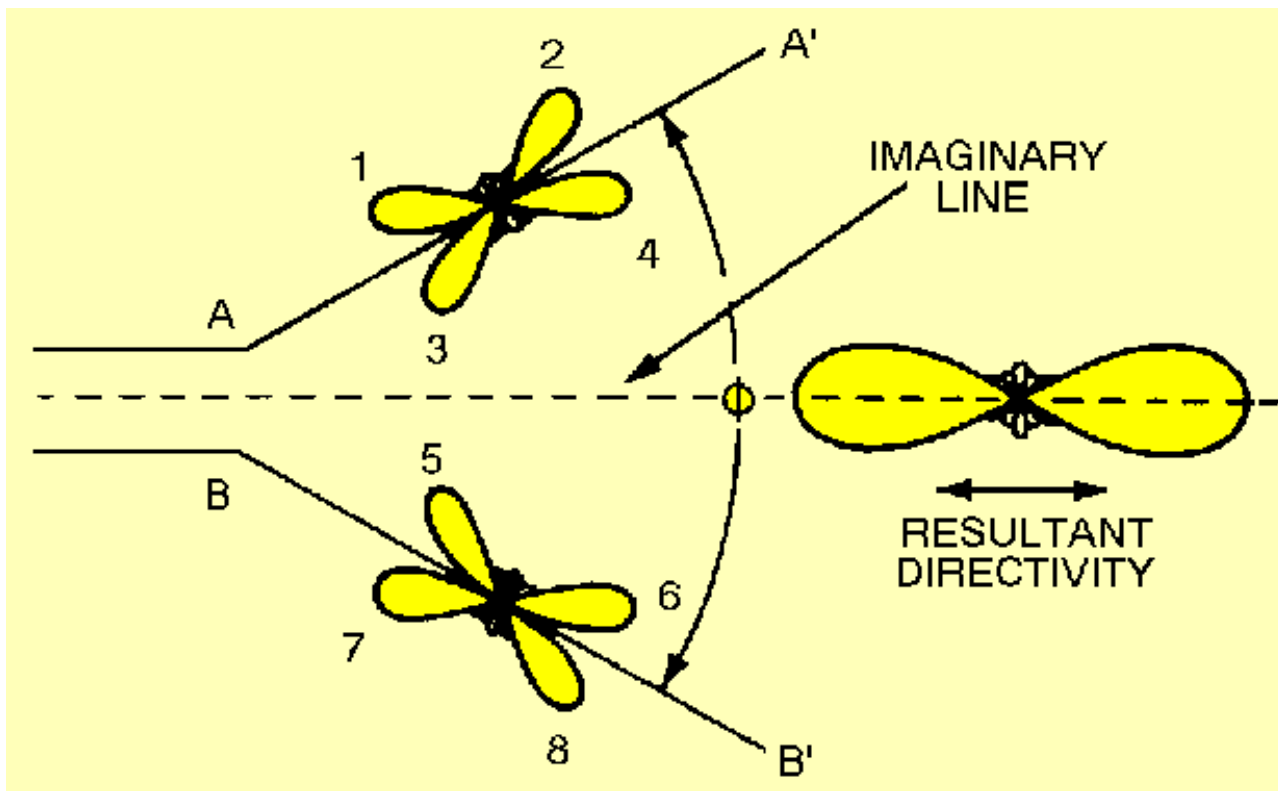

Figure 4-36. - Formation of directional radiation pattern from a resonant V antenna.



Q.46 What is the polarity of the currents that feed the V antenna? Answer

[[Back](#)] [[Home](#)] [[Up](#)] [[Next](#)]

[Order this information in Adobe PDF Printable Format](#)

Dinner at Red Lobster on us!

Hungry? Answer a few questions...

...get a **\$50 Restaurant Card**



[Privacy Statement](#) - [Press Release](#) - [Copyright Information.](#) - [Contact Us](#) - [Support Integrated Publishing](#)

The RXO Unitenna

by R. D. BROWN G3RXO
email: standardtrees@btconnect.com

WHILST touring New Zealand some years ago, I needed a portable all band HF antenna and conceived the following design concept which produced surprisingly good results. Back in the UK, I did have time to construct and test it and it worked surprisingly well. It is extremely cheap, extremely light, and works continuously over an extremely broad bandwidth. It is non-resonant, vertically polarised and out-performs a ground plane throughout a 3:1 frequency range. Accepting a loss of some 3dB from a ground plane, its useable frequency range is some 5:1. It has very low angles of radiation throughout the range, requires no radials, and is not susceptible to static.

My thinking was along the following lines:

(1) Consider a vertical dipole, it's current distribution and resultant polar diagram.

(2) Consider it as a folded dipole.

(3) Consider it's current distribution and polar diagram if it is fed off centre. The dissimilar currents in the two elements of the dipole are within one evanescent induction field and therefore cumulative as to radiation which can give rise to an overall current distribution and polar diagram which changes very little with change of frequency.

(4) By feeding at approximately one third of the way along the dipole the current distribution and polar diagram vary approximately from that of a vertical dipole to that of a vertical quarter wave over a frequency range of some 3:1; for example from 7MHz through to 21MHz.

(5) Above the antenna's maximum useable frequency the polar diagram becomes split and of high angle.

(6) As the applied frequency is reduced below its normal range the polar diagram remains much as for a vertical quarter wave, but with diminishing efficiency, although still useful over a frequency range of some 5:1.

(7) Since the antenna is a closed loop it is less susceptible to static.

(8) It requires no radials and therefore incurs no ground losses.

(9) It is fed with a tuned line which should be as perpendicular to the antenna as possible.

(10) Variation of the feed point to about 25 per cent from the antenna's end results in slightly better current distribution, but reduced bandwidth. The optimum point is around 30-35 per cent from the end.

(11) It is cheap to produce, lightweight, portable, unobtrusive and has virtually no power limits.

The original antenna was made of regular single core conductor taped down each side of lengths of plastic waste

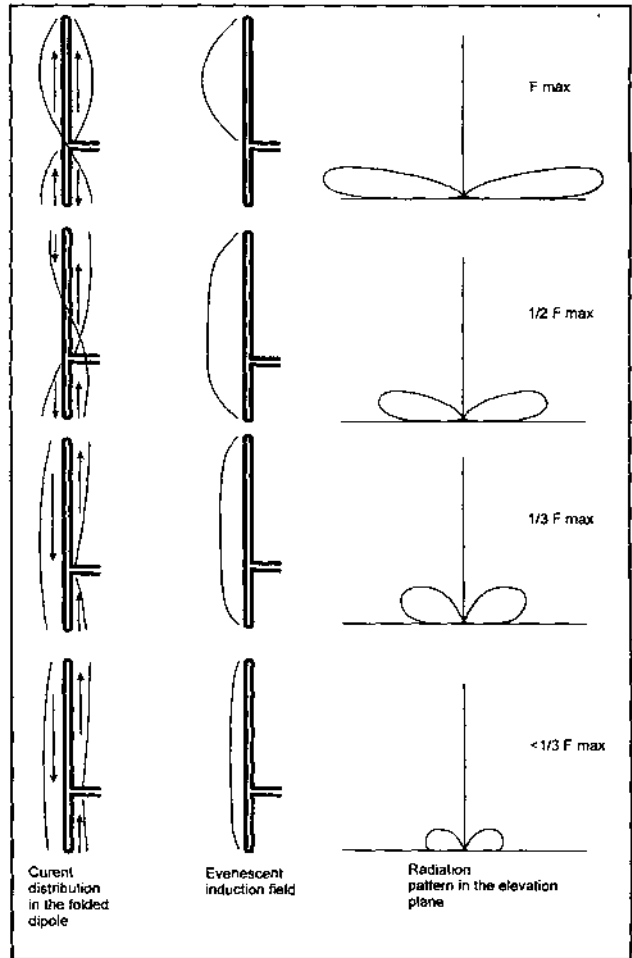

Figure 2.

pipe and guyed with bricklayer's line. For example; practical dimensions are a 9.2m dipole, fed 3m from base and about 1m above ground; coverage 7MHz to 21 MHz continuously with full efficiency. Pro-rata for other frequency ranges.

I found the antenna to be surprisingly quiet with respect to background noise and very effective at low angles and long range. I hope that others will give this design a try and would be most interested to learn of their results with it. β

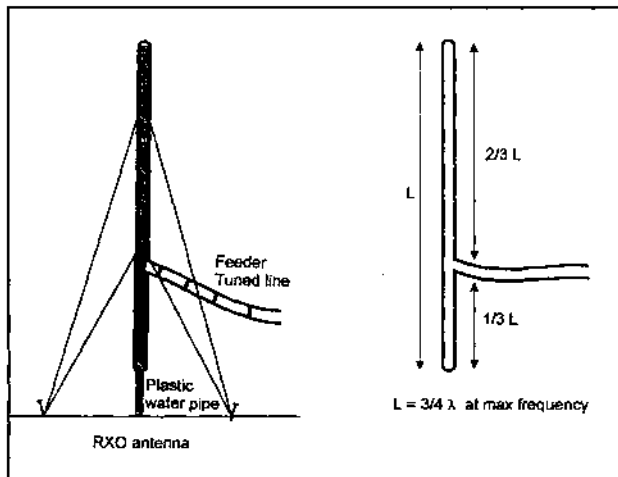

Figure 1.

Support our Advertisers

As the number of firms advertising in *Break-In* dwindles (due to either lack of advertising revenue or through having gone out of business) it is all the more important that all members support those advertisers who still support *Break-In*.

If any member knows of a prospective advertiser, please let the Advertising Manager know.

TRANSPORTABLE VERTICAL ANTENNA

This vertical was built for me by Luis, CT1BYR, a skilled ham and homebrew fan - everything from smd component level to large antenna array construction.



The vertical's slim silhouette stands almost 10 metres high.

After numerous conversations with Luis regarding transportable antennas he came up with this solution for me to take on my trips to the Azores. Knowing that I often use an automatic SGC-230 antenna coupler and so tuning would not be a problem, he suggested combining this with a random length vertical. Operating away from home is also about having redundancy plans - this antenna can also be used if the SG-230 is unavailable as a standard quarter wave vertical, on most of the HF bands, simply by altering its length.

The antenna stands over 9 metres high when fully erected and has four levels of guying cables to withstand the harsh weather associated with this part of the world. Built from stainless steel, instead of aluminium, this provides added weather resistance and durability. As does its slim silhouette for minimum wind resistance. Thin walled stainless steel piping was easier to find at our local hardware store and although slightly heavier than aluminium this was not a problem as it is still easily carried by one person. The base is made from a nylon block

with a deep circular recess to accommodate the bottom section and isolate it from ground. A couple of bolts are also screwed to this same block to attach the antenna's RF ground wires - the more the better.

To allow transportable operation and easy set-up, Luis used a telescopic solution for the



CT1BYR preparing to raise the vertical.

person. It saves him having to hold the bottom section vertically steady while telescoping out and tightening the remaining four sections.

vertical element. Five 2 metre pipes all slotting inside each other reminds us of a car radio antenna on a larger scale. Each of the lower four section ends have a guying clamp to affix three guy ropes and when tightened, give the vertical rigidity and prevent the slimmer elements from slipping back inside the larger ones. This gives us a total of twelve guy wires which may be reduced for calm weather operating. In fact, the bottom level of three guy ropes are practically only used to facilitate raising the remaining upper sections by a single



Details of the telescopic antenna sections with guying clamps.

Lowering the antenna is just as easy as raising. For storage or travel, the vertical element, ground wires and guy cables fit inside a 2 metre long cardboard or plastic tube making it easily transportable and an ideal antenna for emergency, field-day or dxpedition use.

[Back to Fun Stuff](#)

DOWNLOAD PROGRAMS FROM THIS PAGE

Visitors since 24th November 2003 ... **053487**

During March-June 2004, visitors averaged 200 per day.

Return to [Index](#)

These are DOS-executable self-contained programs each occupying a single binary file. No use is made of external software. This ensures portability between DOS/Windows machines.

There is a brief one-line description following each program's name.

Approximate file sizes are from 25 to 70 kilobytes. Download, or run without downloading, in a few seconds. Just click on a program's underlined name.

Download from here to a Windows Desktop icon or collect programs in a common Windows folder of your own chosen name. There's no un-zipping inconvenience. Programs can be run immediately after download.

To run a program click on its desktop icon. If the program does not entirely fill the screen then look along the top tool bar and click on the button which expands the display outwards.

The mouse is not available when the program is running full screen. Close the program from within by hitting either the 'E(xit)' or 'Q(uit)' key when displayed in the menu on bottom line 25. You will be immediately returned to the desktop.

If the program aborts into DOS due to entry of 'impossible' data, to return to Windows Desktop type the DOS command 'EXIT' against the C>prompt followed by the enter/return key. Or to run the program again type the program's name alongside the C>prompt. No harm will have been done to your computer, operating system or to the program itself.

Remember, when in DOS, the DOS 'EXIT' command, followed by the 'Enter' or 'Return' key, will always return you to the Windows DeskTop. No need to get lost!

[RJELOOP1](#) *

Performance of Transceiving, single-turn, magloop antennas of various regular shapes.

[RJELOOP2](#) *

Performance of Transceiving, single-turn, magloop antennas of rectangular shape.

RJELOOP3 *

Analysis of receiving, multi-turn, square, loop (or frame) antennas, ELF to HF.

HELICAL3 *

Continuously-loaded, helically-wound HF antennas, top-capacitance loaded with a rod.

TOROID *

Ferrite & iron-dust cored, toroidal coils. Dimensions, Core permeability, Turns, uH, pF, Freq.

VERTLOAD *

Base-fed vertical antennas, coil-loaded at any height, with coil design.

RADIOETH *

DC, power freq & RF characteristics of a single shallow-buried ground wire.

EARTHRES *

Ground electrodes. Resistance msmnts and predictions, rods, wires, plates, mats,

TANT136 *

LW & MW performance of small T-antennas above a system of buried ground radials.

ENDFEED *

HF performance of Inverted-L antennas above a system of buried ground radials.

LINEAR1 *

Models simple Class-AB, Push-pull, Bipolar Linear RF power amplifiers up to 30 MHz.

BALUN4 *

Design and performance of HF transmission line ferrite-core transformers, Z-ratio 4-to-1.

RJELINE1 *

Performance of openwire lines, Power freqs up to UHF, for any complex termination.

RJELINE2 *

Full analysis of balanced-twin lines, 20Hz-1GHz, for any complex termination.

COAXPAIR *

Full analysis of coaxial lines, Power freqs to UHF, for any complex termination.

RJELINE3 *

Full analysis of balanced lines with facilities for HF line xfmr design.

TRAPDIP *

Design and performance of 2-band trapped dipole antennas including trap design.

PHASENET *

Design of T & Pi phase-shifting networks for use with antenna arrays.

TPINET *

Design of T & Pi impedance-matching and phase-shifting networks.

SWR-FREQ *

Compare simple & folded dipoles. Input Z. Feedline VSWR vs freq. Bandwidth.

SOILSKIN *

Enter soil R and K characteristics. Display a table of skin depth vs frequency.

COAXRATE *

Power ratings of solid polythene coax cables vs dimensions and SWR. 0.3 to 3000 MHz.

ZL_ZIN *

Compute antenna feedpoint impedance from measured line input impedance, known Z_0 & length.

SOLNOID3 *

Single-layer, air-core coils of all proportions. Dimensions. Turns. Temp rise vs applied volts.

MAGLOOP4 *

Performance of regular-shaped magloop antennas versus height and type of ground.

PADMATCH *

T, Pi and L resistive matching-pad design using standard-range resistor values.

MIDLOAD *

Design of very short, centre-loaded dipoles above lossy ground. With coil design.

LCR *

Full analysis versus frequency of behaviour of an L+C+R parallel-tuned circuit.

SWRMETER *

Modelling, design, calibration & operation of HF SWR meters using a ferrite current xfmr.

LOADCOIL *

Design of short vertical antenna + loading coil. Slide coil up/down to maximise effncy.

PI_TANK *

Design Pi-match output cct for RF power amp. Effncy, harmonic suppression, phase shift.

ZOC_ZSC *

Calculate Trans-line Z_o, L, C, R, G, dB, VF from open and closed input impedance measurements.

Pi_L_Net *

Design Pi and Pi-L output networks for RF Power amps. Effncy, harmonics, phase delay.

TETRODE1 *

Design of Class A, AB1, AB2 and C RF Power Amplifiers, using beam tetrodes or pentodes.

TOPHAT2 *

Short vertical antenna with Top-capacity-hat made with N radial wires. L-tuner values.

RJELINE4 *

Analysis of balanced-pair transmission lines. Line xfmrs with complex terminations.

T_TUNER *

Design & power efficiency, etc., of T-match tuning networks for transmitting antennas.

GRNDWAV3 *

Groundwave propagation. Field strength vs pathlength, terrain and frequency, VLF to HF.

DIFFRAC1 *

Radio propagation. Diffraction over a single obstruction. Tx output to Rx input.

DIFFRAC2 *

Radio propagation. Diffraction over two successive obstructions. Tx output to Rx input.

LINOSITE *

Simple Line-of-sight radio links. Approximate aperture, beamwidth, propagation loss etc.

MATCHSEC *

Impedance matching by inserting in antenna feedline a short section of different Z_o .

BOTLOAD2 *

Inductance and bottom-loading coil design, or tune pF, for vertical or sloping antennas.

L_TUNER *

Calculate coil & capacitor values of an L-Network to match any pair of complex impedances.

WIRESKIN *

Skin resistance vs frequency of a single wire, an open-wire line and a dipole.

SELECT_1 *

Simple receiver preselector is a tapped parallel tuned circuit. Also coil design.

TWOCOILS *

Design & position two common-axis solenoids for desired coupling and mutual inductance.

DIPOLE3 *

A dipole at any height + balanced line + balun + coax line + L-match tuner L & C values.

DIPCAGE2 *

Cage dipole of N wires, resonant length, bandwidth vs SWR, end-effect, feedpoint impedance.

ADDALOAD *

Location and value of L or C loading component needed to resonate an antenna wire.

TRIODE1 *

Triode RF power amplifiers. Class-A, AB, C. Tuned tank or Pi-match output cct component values.

MULTILAY *

Design of multilayer coils wound in bobbins or other formers. 3 MHz and below.

WINDOM2 *

Performance of 1/2-wave horizontal dipole fed off-centre via vertical single-wire feedline.

FEEDPOWR *

Crude estimate of power radiated from coaxial line feeding 1/2-wave dipole without a balun.

COAXTRAP *

Design of antenna trap using length of coaxial line wound as solenoid on a coil former.

TWINTRAP *

Design of an antenna trap using length of twin-line wound on coil former. (Experimental)

OSCTRACK *

Superhet receivers. Optimum tracking of RF and oscillator tuned circuits. L & C values.

STUMATCH *

Match antenna input impedance to feedline with stub line xfmr. Balanced or coaxial lines.

STUBTUNE *

Match antenna input impedance to twin feeder with stub line xfmr. Includes xfmr efficiency.

LPF_HPF *

Simple L and C High and Low-pass filters. T and Pi Sections. Insertion loss vs freq.

BANDPASI *

Simple L and C bandpass filters. T and Pi Sections. Insertion loss vs freq.

INV_VEE *

Performance of resonant 1/2-wave Inverted-Vee and Dipole antennas including feedlines.

RHO_SWR *

Exact values of Rho and SWR on mismatched lines. Compare with measured values.

WHIP_1 *

Signal strength received on whip antenna + un-un transformer + coax line + receiver.

TWOHOPS *

Skywave Trigonometry and insight into how losses are proportioned along a radio path.

HARM_GEN *

Simple single-transistor harmonic generator. Performance and behaviour vs frequency.

R_X_SWR *

Feedpoint Impedance and SWR of an antenna in the vicinity of resonance.

CHOKEBAL *

Design and performance of a choke balun in conjunction with feedline and antenna.

BALCHOKE *

Better, recommended, version of program ChokeBal above. Changes in input data.

XTL_SET *

Design, performance, of crystal set, or preselector, using two coupled tuned circuits. From Tx to phones.

RADIALS2 *

Performance of a set of shallow-buried ground radials considered as transmission lines.

Return to [Index](#)

Short Vertical Antennas and Ground Systems - VK1BRH

** Copyright (c) Ralph Holland 1995, Copyright (c) Amateur Radio 1995.*

Introduction

There have been a number of articles discussing the merits or otherwise of various types of ground systems. The analysis of such systems is complicated by the facts that practical ground system parameters are difficult to quantify, antennas are situated in less than ideal locations, and literature, that may provide insight into what is happening, often does not present the information in a practical or applicable form. Often the reader is left to extrapolate beyond the bounds of presented data and arrive at the incorrect conclusion. Some folk-lore has been generated as a result of these types of difficulty; one such lore is 'the higher the better', which is an over-generalisation if said without qualification.

Activities

I am interested in 160m operation; it is a challenge to develop reasonably efficient antennas for this *'top band'*. I am also interested in mobile and portable work so I constructed antennas and experimented a bit. It was difficult to quantify the results and performing alterations was rather tedious, so I turned to computer simulation.

After performing several different simulations I developed the feeling that it should be possible to optimise the efficiency of an antenna by altering its earth currents and through the interactions with the mutual impedance of the antenna and its ground image. This turned out to be a very fruitful study, although I initially thought the results were dubious!

Simulations

Fortunately non-ideal antennas have been under analysis by various organisations and many papers have been written covering the theoretical aspects. One organisation of note is the [Lawrence Livermore National Laboratory](http://www.llnl.gov) (LLNL), which was commissioned by the U.S. Department of Defence to perform theoretical and practical analysis of various antenna systems. Some of this material has been declassified and is now publicly available.

During this period several computer-based antenna simulation programs were developed; of note is the Numeric Electromagnetic Code (MINI-NEC, NEC-2 and NEC-3 and now NEC-4).

NEC-81 is the name of the earlier PC version of NEC-2. NEC-81, NEC-2 and MINI-NEC are available through the [Applied Computation Electromagnetic Society](#) (ACES); contact Dr R.W. Adler, ECE Department, Code EC/AB, Naval Post Graduate School, 833 Dyer Rd, Rm. 437, Monterey California, 93943-5121, U.S.A or Fax 1 408 649 0300 or E-mail 554-1304@mcimail.com, for the conditions, membership and handling fees if you want to obtain these programs.

Post publication note: public domain software now available at [Unofficial NEC2 pages](#).

NEC-2 can model antennas in proximity to lossy ground. The lossy ground analysis is based on work by Sommerfeld; and appears to yield realistic feed-point impedances and reasonably quantifiable losses.

System Performance

The simulation goal was to determine the relative merits of elevated groundplanes for short vertical systems, ie up to 0.25 wavelengths.

Traditionally, it has been convenient to measure the feed-point impedance of the lossy antenna system and compare it with the ideal (theoretical) case. The feedpoint resistance for vertical antennas is called the base resistance (R_b); R_b is composed of the useful radiation resistance (R_r) and the collective loss resistance (R_l). R_r can be evaluated theoretically, it would be the R_b of an antenna over ideal infinite ground.

R_r can be obtained by the additional simulation of the ideal ground model, effectively doubling the simulation time to obtain results. Fortunately, NEC-2 calculates the amount of power radiated around the region of the antenna and divides this by the applied power. This ratio depends upon whether the model is simulated in free space or over ground.

The radiation region of an antenna in free-space is a solid sphere so this ratio should be unity. The radiation region is a hemi-sphere when the antenna is situated against an infinite ground, in which case the value should be close to two; this is due to the ground reflecting power into the upper hemisphere (effectively up to 3dB of gain). This ratio is also used to gauge the stability of the model; if its value greatly exceeds the expected value then the model has failed.

Post publication note: an antenna may exhibit up to 6dB of gain over its free-space radiation pattern due to ground reflection in some directions.

It is a simple means to use this power ratio to determine the antenna's efficiency. Note that the radiation resistance can be derived via: $R_r = R_b / \text{efficiency}$; I used this analysis to cross-check the results of some simulations.

Results

The term displacement is employed for the height of the groundplane above ground; this avoids confusion with antenna element lengths. All lengths, heights and displacements are measured in wavelengths (λ) unless otherwise indicated.

Resistance versus Groundplane Displacement

Figure 1 shows the effects of various displacements upon a 0.10 wavelength vertical antenna with three 0.10 wavelength radials at 1.825MHz. I chose the average ground parameters: relative dielectric constant 13 and conductivity of 5 milli-Siemens per meter (13,5); which are typical for dry clay and indicative of the Canberra region.

Note that the R_b is high at zero displacement, much higher than R_r , so R_b is largely composed of loss resistance at this point, and the antenna is primarily heating the ground! Notice how difficult it is to determine the optimal displacement from the R_b and R_r curves on this graph.

Efficiency versus Displacement

Figure 2 shows the antenna's efficiency over the same range. Notice that there is an initial peak at fairly low displacements. Advantage will be taken of this effect.

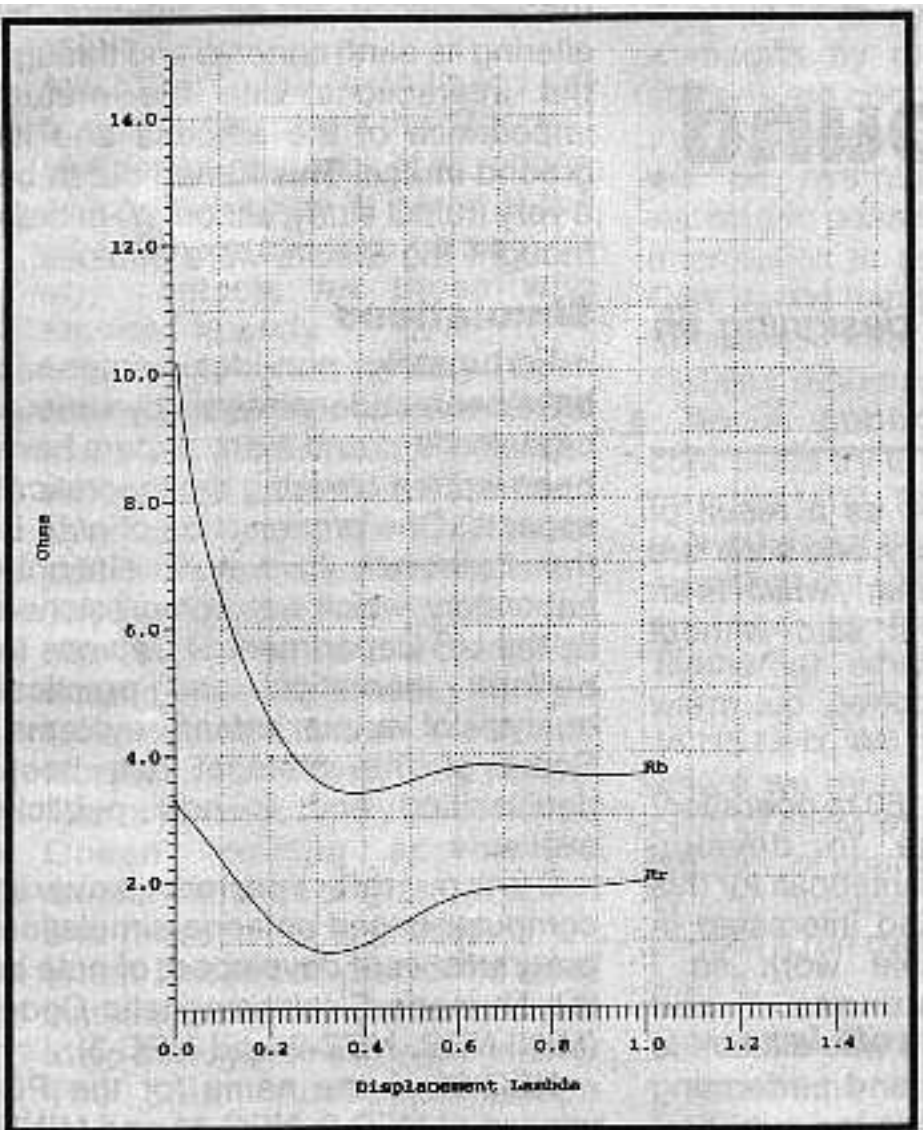

Fig 1 — 0.10 wave radiator/radials * 3 @ 1.825 MHz (13,5).

Fig 1 - Resistance vs Displacement

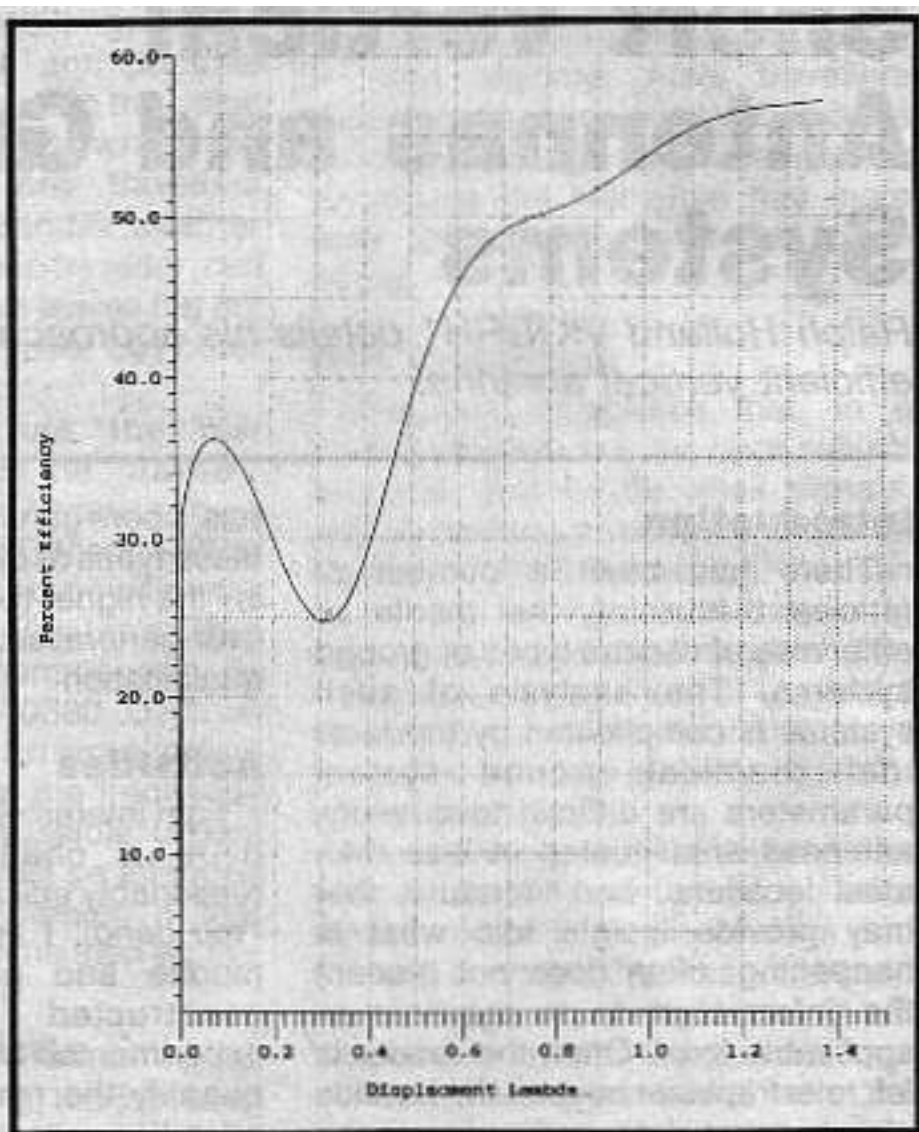

Fig 2 — 0.10 wave radiator and radials * 3 @ 1.825 MHz (13,5).

Fig 2 - efficiency versus displacement

Displaced Antennas versus the Number of Radials

Figure 3 is the comparison between the conventional groundplane, situated on or in the ground, and the elevated groundplane. The simulation parameters are 1.825Mhz, 0.25 wave radiator and radials, and ground parameters (13,5). The integer simulation points are joined to form curves (I did not actually simulate a non-integral number of radials).

Notice that the elevated curves are asymptotic to a horizontal line about 37 percent efficiency. The elevated curves are more than satisfactory at the three to four radial mark; the traditional ground screen doesn't even get near this at 32 radials. Recall that the typically quoted commercial design figure is to strive for 120 ground-based radials.

Variable Radiator, Radial Length and Displacement versus Number

of Radials

Figure 4 illustrates the effect of radiator and radial lengths. The simulation is at 1.82MHz and for ground parameters (13,5). The top curves represent the elevated groundplane, while the bottom curves are for ground-based antennas.

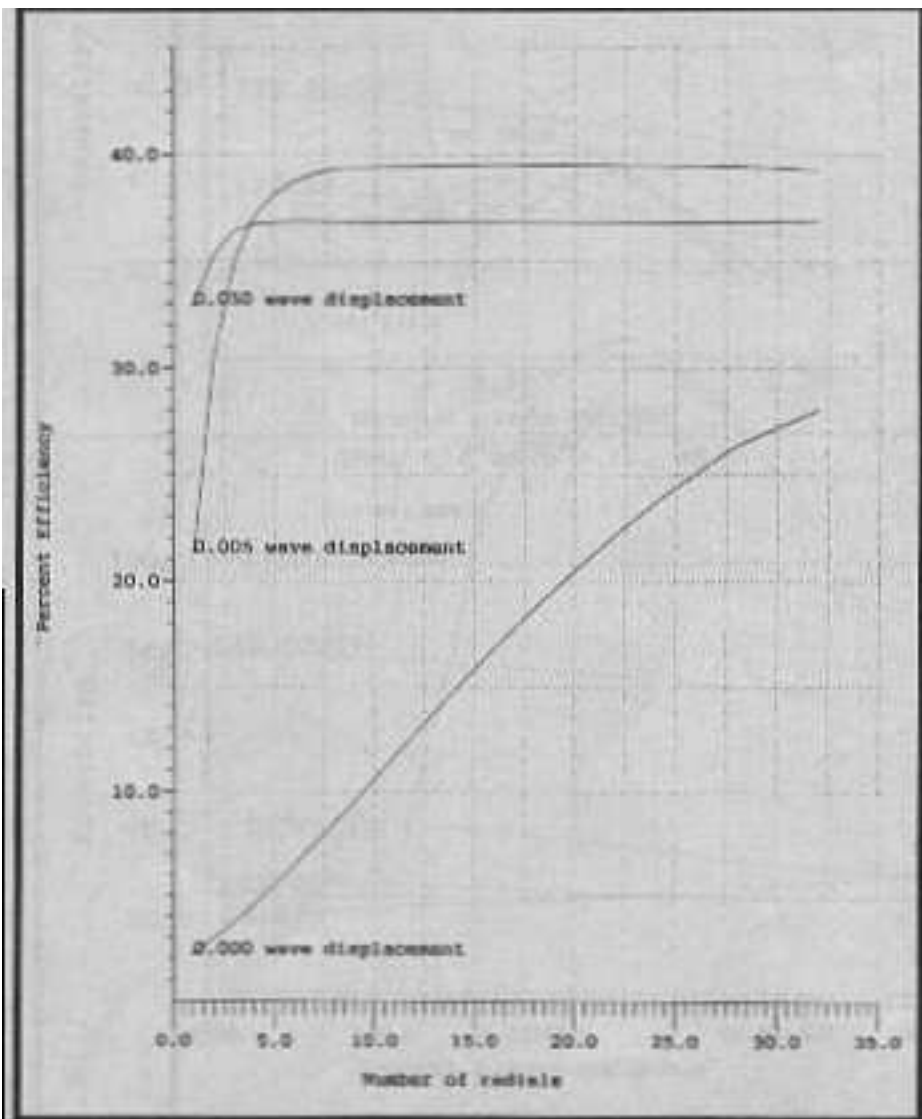

Fig 3 — 0.25 wave radiator/radials labelled by displacement.

Fig 3 - Comparison between tradition and elevated elevated groundplane

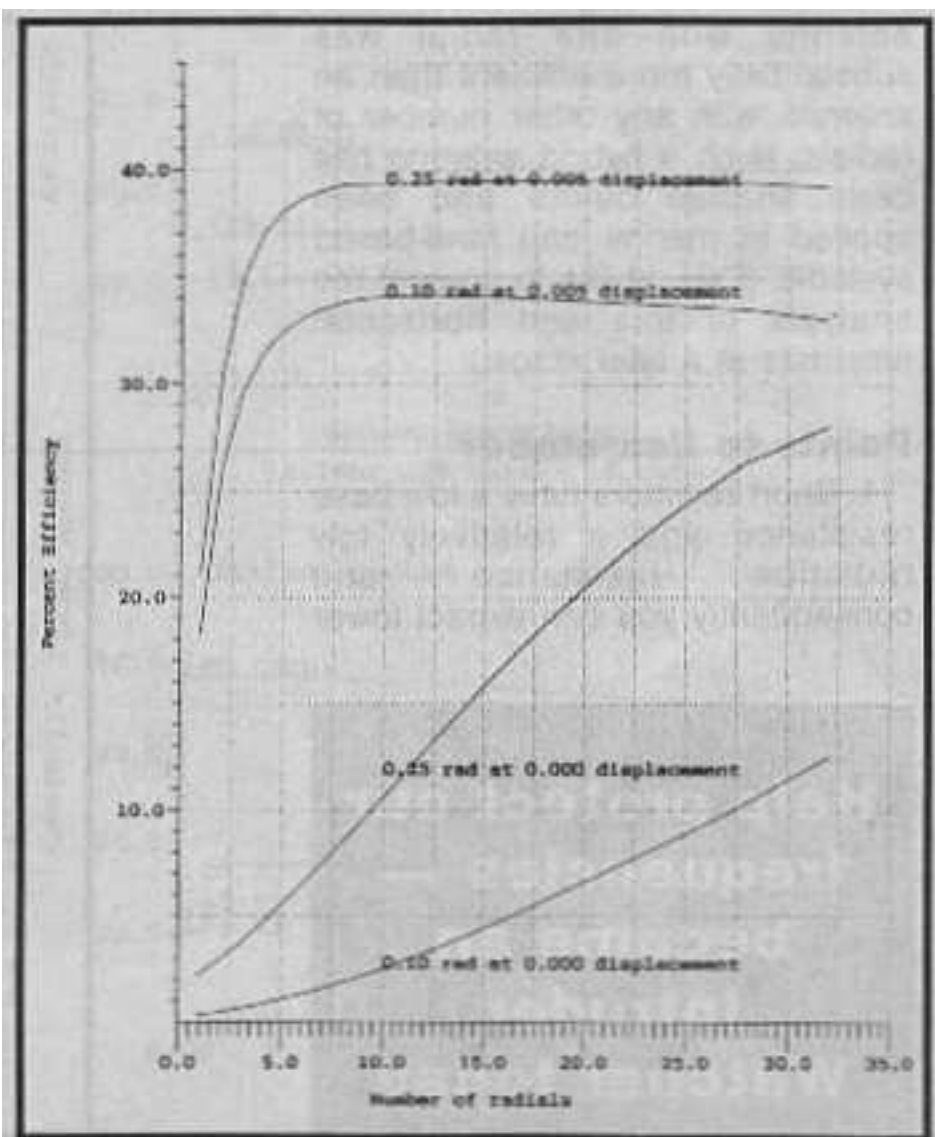

Fig 4 — Radiator/radial length and displacement.

Fig 4 - Efficiency versus number of radials at various heights and lengths

Variable Radiator and Radial Length at a constant Displacement

Figure 5 is the graph for a 1.825Mhz vertical, which was simulated for Eric, VK3AX. This simulation was based on 3 radials mounted at 20' (woolshed height) over typical clay soil (13,5). We were interested in the affect of the antenna height and radial length. The radiator length was labelled on the graph in wavelengths and feet. You will notice that short radiators performed quite well with radial lengths of 0.15 wavelengths and appear worthwhile constructing. When the radiators are lengthened from 0.06 wavelengths to 0.15 wavelengths, the efficiency improves by 5 percent; not much gain results from extending radiators up to the full 0.25 wavelength, in fact, this length was noticeably less efficient than the 0.148 wavelength radiator. In all curves there is an optimal radiator and radial length. Notice how the optimal radial lengths are noticeably less than a quarter wave for the shorter radiators.

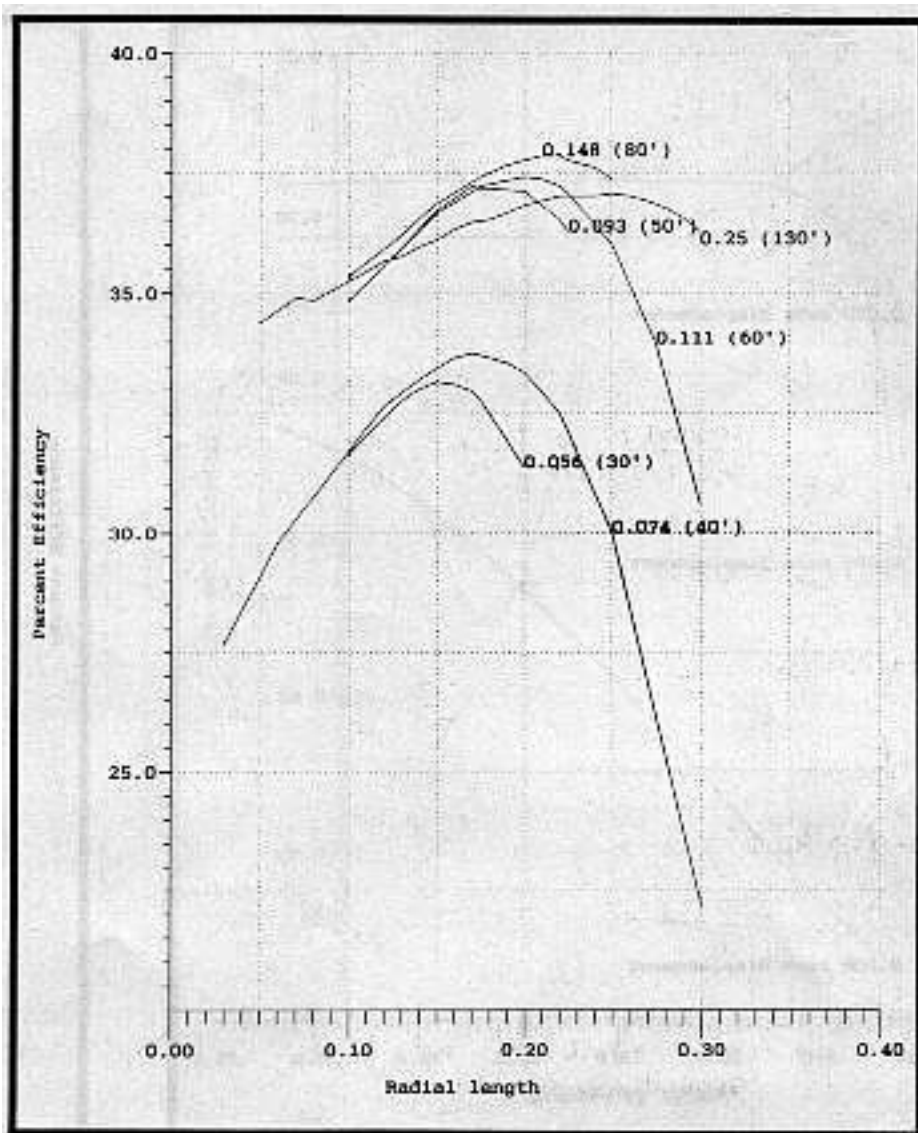

Fig 5 — Fixed displacement at 1.825 MHz 20' (13,5).

Fig 5 - 1.8 MHz antenna with 3 radials at 20'

Efficiency of Elevated Groundplane and Frequency

Figure 6 shows the effects of changing frequency. The analysis has been performed for the 160m, 80m, 40m and 20m bands so you can apply these results to your favourite band. All radiator and radial lengths were 0.25 wavelength, in all cases only three radials were employed.

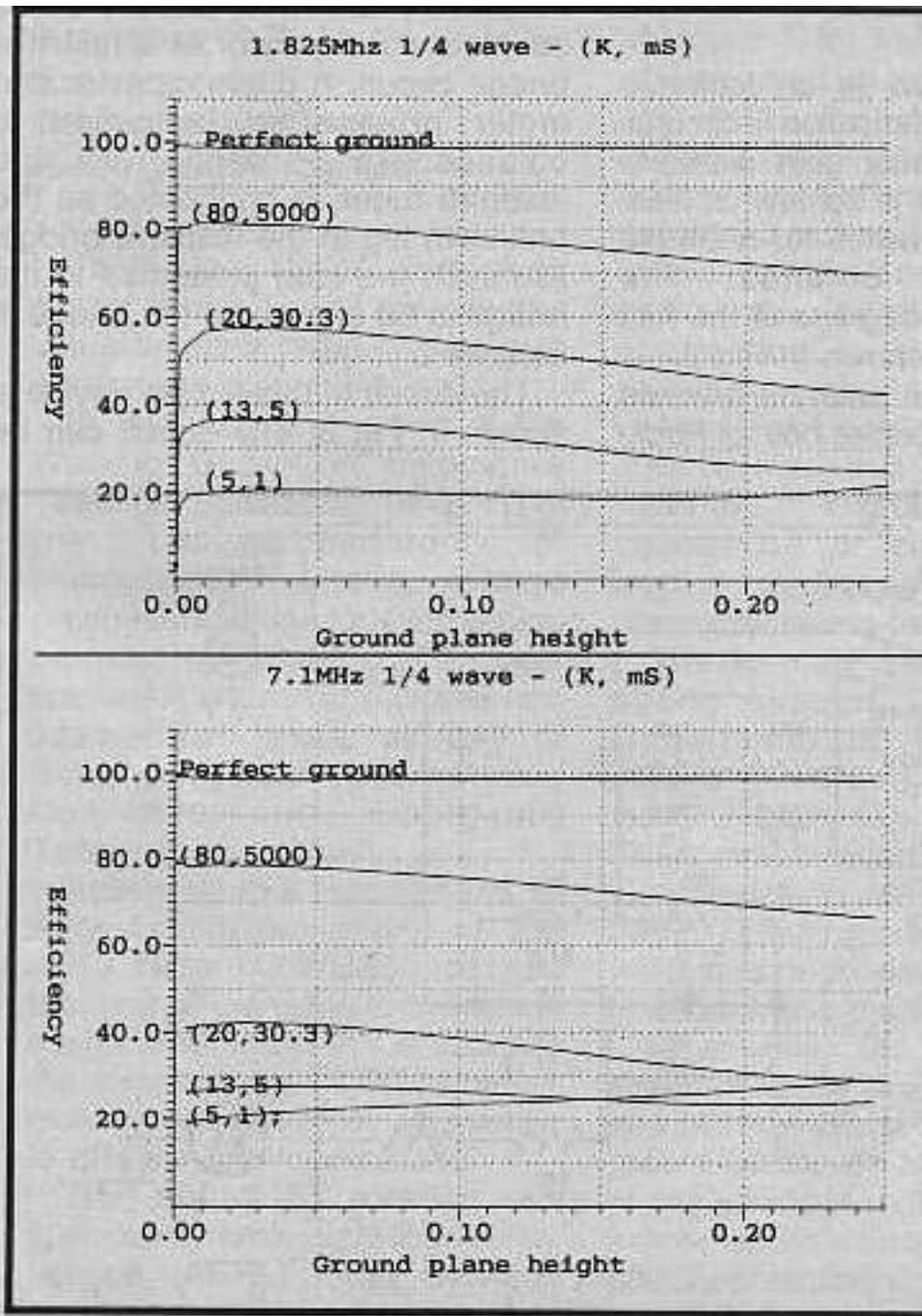

Fig 6A - The effects of changing frequency.

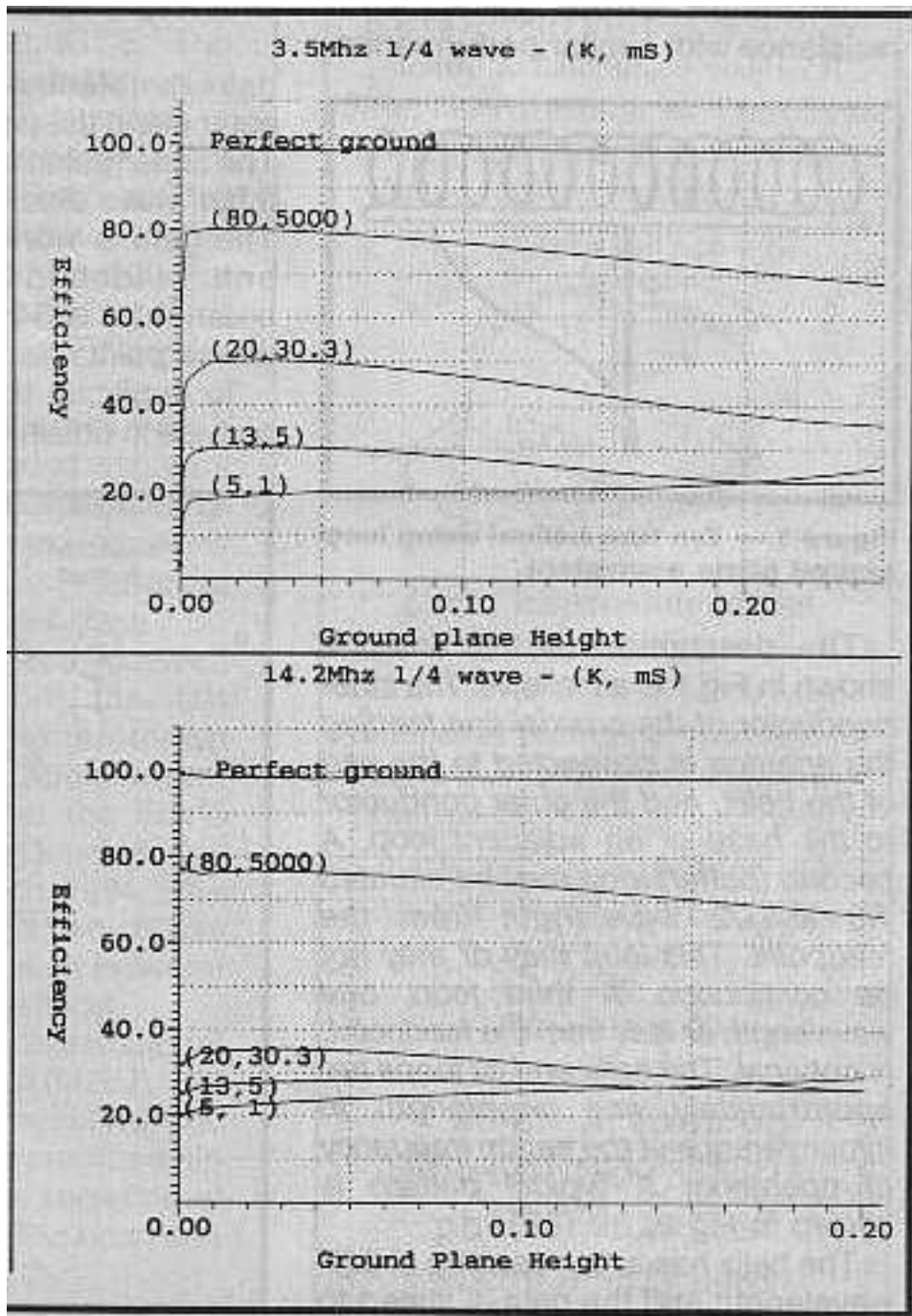

Fig 6B - The effects of changing frequency.

Each curve is labelled by its ground parameters. The curves could be named from top-to-bottom as: Perfect, Sea water, Good, Average, and Poor respectively. Recall that the Average curve, labelled (13,5) is indicative of the dry clay soils.

Notice that the curves peak between 0.002 and 0.05 wavelengths displacement. A more difficult observation, due to the scale of the graphs, is that the curves point steeply towards zero efficiency at zero height (you can obtain a better indication from Figure 2).

Conclusions

From the Figures it is obvious that the simulated antenna efficiency declines dramatically when the groundplane displacement approaches zero.

With three or more radials the radial length is more important to the overall efficiency than the number of radials, with a few exceptions. An interesting side-effect I noticed is that under certain conditions a vertical antenna with one radial was substantially more efficient than an antenna with any other number of radials; such a hybrid antenna has been studied before and been applied in marine and land-based systems. (I would like to present the analysis of this and horizontal antennas at a later stage.)

Points to remember:

1. Short radiators have a low base resistance and a relatively low radiation resistance and consequently you can expect lower efficiency. However, short radiators can still be quite efficient; the shorter radiators require shorter groundplanes and are more optimum at lower groundplane displacements - don't write-off a short radiator! Do take into account the lower feedpoint resistance and consequential difficulties with feeder and element losses, some form of atu at the base is the best. Also note that a short radiator has a very high base impedance, caused by its capacitive reactance, and that the rf voltages at the base are very high!
2. There is an optimal height for an elevated groundplane, that height is not at ground zero, and is typically around 0.05 wavelength. (The statement the higher-the-better is not always true for such systems.) Do not place your ground system on or in the ground unless you have space, time and materials for about 120 radials, unless you are fortunate to have excellent ground, or the desire to hide your ground system. (You may be able to see from Figure 4 that there is a lot to be gained from watering an inadequate ground system - so don't write-off that folk lore!)
3. The efficiency curves are forgiving and somewhat broad; displacements as little as 0.005 wavelengths can be tolerated; some curves actually peak around 0.01 wavelengths.
4. Large numbers of radials are not required for elevated groundplane systems. Three or four radials are sufficient, doubling the number does not double the efficiency.
5. The elevated groundplane system is more efficient at lower frequencies.
6. A lot can be gained by placing your antenna near swamps, lakes and in close proximity to the sea; you should expect substantial improvement, often more than 3db in these cases.

7. Lastly, these results are only as good as the simulation program. However, this program is good at modelling linear antennas close to lossy ground. NEC-2 has been validated numerous times; even so care must be taken because inappropriate use has caused the model to fail.

I have also performed simulations for elevated groundplanes with an underlying secondary ground screen placed on the ground. It is detrimental to connect the elevated groundplane to this form of lower ground system. Note the recommended commercial practice to terminate radial systems with a ground stake - I would highly recommend against such practice; the situation is made even worse if the ground stake is under the feedpoint rather than at the ends of the screen.

I originally thought that this grounding anomaly was an artefact of NEC-2, but I have subsequently read the preliminary publication ['Recent Advances to NEC: Applications and Validation'](#) by G. J. Burke, 1989, which investigated these effects and others; he used the new improved and classified NEC-4 to model situations for several typical broadcast antennas and antennas below the ground. Burke found, to my surprise, and others, that the recommended grounding practices are detrimental. Burke's findings were based on the relative communication efficiency (RCE) of the antenna measured in terms of field strength at some distance outside the near field, a more appropriate value, rather than the efficiency figure I employed.

Bibliography

The MINI-NEC and NEC programs are based on the Method-of-Moments (MoM); you can find a description of this method in "[Antennas, Second Edition](#)", by John D. Kraus, McGraw Hill 1988.

Another book, which describes the foundation of the technique, is "[Field Computation by Moment Methods](#)", by R.F.Harrington, McGraw Hill 1961. Post publication note: This classic has been reprinted by the [IEEE](#) and is available at a discount if you are a member.

The hybrid vertical - horizontal marine dipole, developed by VK3AM, is described in "[Hf Antennas for All Locations](#)", by L.A. Moxon, G6XN, on page 154.

The "[ARRL Antenna Compendium](#)", Volumes One and Two, (now Three, Four and Five) are also interesting reading for antenna construction and modelling.

The book review "[Computational Electromagnetics: Frequency Domain Method of](#)

[Moments](#)" by Edmund K. Miller, Louis Medgyesi-Mitschang, and Edward H. Newman was extracted and printed in an ACES newsletter. The extract stated that the review contains 528 pages and recommends several books.

One book of recent publication is: "[Generalised Moment Methods in Electromagnetics](#)", by J.H. Wang, John Wiley and Sons, NY, 1991. I believe this would be for the serious MoM enthusiast.

* Terms

This article was first published in Amateur Radio Volume 63 No 10, October 1995. 'Amateur Radio' is the journal of the [Wireless Institute of Australia](#). Both the author and the WIA hold copyright. No reproduction is permitted for commercial purposes without express permission of the copyright holders. (mailto:). At the time of publication, he author was a member of the [VK1 WIA](#).

This article seems to be the most popular article on my website. The article was updated with post publication notes on 28 Nov 1998, and several hypertext links have been added for your convenience. I modified the article on the 10 Aug 2004 so it uses CSS and because of several requests from readers I have made the graphs scaleable. I apologize for the lack of clarity as the original .jpg files do not scale well. Unfortunately I no longer hold the original data or software from which I generated the graphs.

The document is best viewed with IE 6 and Opera 6. Sorry it may not print properly until I fix the CSS.

This page has been hit **16756** times between 2000-10-01 and 2004-07-30

Usage [statistics](#) for all pages.

Quickie Vertical

KQ6RH

(C) 1998, 1999, 2000

Ray Jurgens

(Up-Dated 2/25/2000)

Quickie Vertical (October 1998)

Hear I am sitting in front of the rig listening to everyone working CQ World Wide, and I don't really have time for this, but I hear a few interesting stations on 20 meters and try to call them. Trying to bust the pile up with 100 watts and my hustler dipole is going to be difficult on this band, so I tune up on 15 meters and there is action, and I have a good wire beam, so I tune up and down the band and can't find a clear frequency. Then I hear some one say that 10 meters is open. So I tune up there, and there is a world of DX coming in. I choose a few interesting ones to call, but can't be heard. I should have expected that, as my antenna for this band leaves much to be desired. It is a vertical above my Hustler dipole, but it has no effective ground plane and SWR no better than 3:1 at its best frequency. With no time to assemble a Quad, I start thinking about a better vertical. Suppose I take the parts for the quad and make a good ground plane and put the mobile whip above it. That won't take long. So I quickly assemble a short 4' mast with a center hub and add four 8' long 1/2" diameter fiber glass spreaders and set in on my test stand in the center of the back yard. I dig into my portable antenna box and find an extra mirror mount (Radio Shack variety) and mount it at the top of the mast. Oh, the bolts are too short for the 1" mast, so I am off to the hardware for 2" bolts. I remembered that I had cut eight #16 solid copper wires for a ground mounted vertical about a year ago, so I unroll 4 of them and attache them to the lower bolts on the mirror mount and tape the other ends to the tips of the spreaders. I then tighten the wires by dropping the hub 30" below the mirror mount which pulls the spreaders into the horizontal position and allows the radials to drop at about 17 degrees. Quickly, I mount the Hustler 10-meter whip, connect the coax, and check the SWR. The SWR is great, 1.1:1, but at 29.6 MHz. So I add two more inches to the stinger and recheck. That gave 28.6 MHz for best SWR which is now 1.2:1. Not bad, a total of a half hour has passed, and the same stations are still holding the frequencies. So I start down the list that didn't answer earlier. To my amazement I work each one within a minute. So there I sat wishing I had time to work the contest.

To complete the story, the radials are 101" inches long. The spreaders were at an elevation of 4 feet above the ground. Later, I raised this to a height of 8 feet, and nothing much changed. I also tried resonators for 12, 15, 17, 20, 30, 40 and 75 meters with equally good impedance matches, but I didn't raise them up. The table below gives the measured SWR and bandwidth for each band. A photo of this antenna is shown below the table. As I really didn't design this antenna, we have to call this one just plane luck. By the way, if you want more radials, it is possible to use two hubs with one rotated 45 degrees to the other. Add four more spreaders to get 8 radials. This might reduce the stinger lengths a little, as mine are fully extended on a few of the bands. The 20 meter Ham Stick wasn't long enough to get down into the CW portion of the band, so I added four alligator clips to the tip of the stinger. This worked about the same as the Hustler, So here is an antenna that can be set up in as little as 15 minutes once you have the parts together. If you paint all the parts black, it is nearly invisible at night and not objectionable by day. Note that this antenna works fairly well on 75 meters, but does not work well on 30 and 40 meters. I'll tell you why some time later after I figure it out.

| Band (meters) | SWR | 2.0:1 SWR Bandwidth | Stinger Length (inches) |
|----------------------|------------|----------------------------|--------------------------------|
| 10 | 1.20:1 | 1.53 MHz | 7 1/4" |
| 12 | 1.05:1 | 1.00 MHz | 11 3/8" |
| 15 | 1.00:1 | 1.44 MHz | 9" |
| 17 | 1.00:1 | 0.52 MHz | 20 5/8" |
| 20 | 1.25:1 | 293 KHz | 15 3/4" |
| 30 | 5.00:1 | -- | 15 1/4" |
| 40 | 2.60:1 | -- | 26 1/4" |
| 75 | 1.00:1 | 33 KHz | 28" |

Table 1

SWR, Bandwidth, and Stinger Length for Quickie Vertical, Using Hustler Whips as a Function of Band

Note, the bandwidth is the SWR bandwidth for 2.0:1, and the stinger length is measured from the top of the compression nut. All configurations use the Hustler MO-3 mast part, and all resonators are the low power versions. It is interesting to note the excellent match on 75 meters. Normally, this whip gives a much lower impedance when set on a good ground plane, so this probably means that at least half of the power is going into the ground, even more is lost in the loading coil, but it still works pretty well.



Quickie Vertical Antenna

Fiberglass spreaders stretch out the ground radials. Central hub is PVC. A Radio Shack Mirror Mount supports

a 10 meter Hustler Whip all of which is supported by a Radio Shack tripod mount for testing.

Item Quantity Description

| Item | Quantity | Description |
|------|----------|--|
| 1. | 1 | 8' 1" OD fiberglass tube for mast (MGS) |
| 2. | 4 | 8' 1/2" OD fiberglass tube for spreaders (MGS) |
| 3. | 1 | Hustler MO-3 Mast section and resonator for desired band (HRO) (AES) etc., Ham Sticks also work. |
| 4. | 1 | Antenna Mirror Mount, (Radio Shack) (HRO) (AES) etc. |
| 5. | 4 | 2" by 1/4" bolts (to replace those in item 4. (Hardware) |
| 6. | 1 | Versi-Hub (RFJ) |
| 6. | 4 | 1/2" Hose Clamps (Hardware) |
| 7, | 4 | Terminal Lugs with holes large enough to pass the 1/4" bolts |
| 8. | 34' | #16 AWG solid copper wire (Hardware, Electrical) |

Table 2
List of Parts for Quick Vertical

[Return to Main Menu](#)

Richard Karlquist

"Rick"

Biographical:

Currently employed by Agilent Laboratories, the central research lab of [Agilent Technologies](#) in Palo Alto, CA

Agilent is the composed of the former Hewlett-Packard Test and Measurement, Semiconductor, Chemical and Life Sciences divisions.

For previous employment see [resume](#).

Professional Publications:

[A New RF Architecture For Cesium Frequency Standards](#)

[A Narrow-Band High Resolution Synthesizer Using a Direct Digital Synthesizer Followed By Repeated Mixing and Dividing](#)

[A 3 to 30 MHz High Resolution Synthesizer Consisting Of a DDS, Divide-and-Mix Modules and a M/N synthesizer](#)

[A New Type Of Balanced Bridge Controlled Oscillator](#)

[The Theory Of Zero Gradient Crystal Ovens](#)

[A Low-Profile High-Performance Crystal Oscillator For Timekeeping Applications](#)

Patents:

[4,785,415: Digital Data Buffer and Variable Shift Register](#)

[5,148,122: Atomic Beam Frequency Standard Having RF Chain With Higher Frequency Oscillator](#)

[5,708,394: Bridge-Stabilized Oscillator Circuit and Method](#)

[5,729,181: High Thermal Gain Oven With Reduced Probability Of Temperature Gradient Formation For the Operation Of a Thermally Stable Oscillator](#)

[6,651,488: Systems and Methods of Monitoring Thin Film Deposition](#)

[6,668,618: Systems and Methods of Monitoring Thin Film Deposition](#)

[6,686,777: Phase Detector Having Improved Timing Margins](#)

[6,765,519: System And Method For Designing And Using Analog Circuits Operating In The Modulation Domain](#)

[6,765,435: Phase locked loop demodulator and demodulation method using feed-forward tracking error compensation](#)

Patents pending: (after 18 months, the USPTO publishes patent applications)

[US20030045261: Frequency Translating Devices and Frequency Translating Measurement Systems with DC Bias Added to a Mixer Diode.](#)

[US20030053178: Frequency Translating Devices and Frequency Translating Measurement Systems That Utilize Light Activated Resistors.](#)

[US20030063626: Method and Apparatus For Synchronizing a Multiple-Stage Multiplexer.](#)

[US20030065988: Circuit and Method For Adjusting the Clock Skew in a Communications System.](#)

[US20030202543: Aggregate Processing of Information During Network Transmission.](#)

[US20030203722: Method of Reducing Power Consumption in a Radio Receiver.](#)

[US20030210108: Lumped Element Transmission Line Frequency Multiplexer.](#)

[US20040120441: Systems And Methods For Correcting Gain Error Due To Transition Density Variation In Clock Recovery Systems..](#)

[US20040119624: System And Method For Divisor Control In A Modulation Domain Divider.](#)

[US20040119514: SystemS And Method For Correcting Phase Locked Loop Tracking Error Using Feed-Forward Phase Modulation.](#)

Note: approximately 8 other patents are pending, but not yet published as of March 2004.

Rick's N6RK Amateur Radio Web Site:

Visit www.n6rk.com to see Rick's ham radio web site.

Genealogy of "Karlquist" family

The name "Karlquist" is not very common.

From time to time, I receive inquiries from others with the same name wondering if we are related.

The suffix "quist" means "branch" or "twig" in Swedish.

Unlike "Karlquist", most names ending in "quist" start with the name of a tree

E.g., "Alderquist" (Alder), "Lindquist" (Linden)

I have listed some [genealogical info](#) in case you are named Karlquist and are curious.

I know I have some distant cousins in Sweden who go by the name "Carlqvist."

Contact Rick

[Send email to Rick](#)

Send snail mail to:

PO Box 2010

Cupertino, CA 95015

10 Meter Vertical Dipole



I was in need of an antenna for my 10 meter beacon, so I decided to build a design I remembered seeing in an issue of QST several years ago. A friend of mine built one at the time and it worked great. It is a simple rigid dipole made from two lengths of 1/2" electrical conduit that are separated by a 5/8" wooden dowel that is inserted into the ends of the conduit and held together with hose clamps. It is necessary to cut two 2" or so long slits in the end of the conduit that the dowel rod is inserted into. This allows the hose clamps to compress the conduit onto the dowel rod to hold it all together. The dowel rod I used is four feet long, so I had about 2 feet in each leg of the dipole for rigid support.

The dipole can be fed directly with coax, or a balun can be used. It can also be fed with twinlead or ladder line. It is important to seal the insulating dowel with epoxy to keep it from rotting. I used the hose clamps to attach the coax to the antenna.

Caps should be placed on each end of the antenna to keep out moisture. I found that the threaded 1/2" PVC caps work well on 1/2" conduit. They can be just placed on the ends but I fixed them on with epoxy. Make sure that this is done after shortening the antenna for best VSWR match.

The length for each leg of the dipole is found using the formula $L=234/F$, where L =length in inches and F =frequency antenna is to be used on. If the antenna is too short, it can be lengthened by increasing the space between them on the insulator

and lengthening each side of the coax or ladder line feed on the dowel.

This antenna must be mounted so that it is insulated from ground. Mine is mounted on a 4X4 and attached to a 2X4 that is buried two feet into the ground. I used U bolts to secure the antenna to the 2X4. This antenna could also be mounted horizontally off the side of a tower.

This antenna could also be built for the 12 meter band, and possibly even for the 15 meter band. However, most conduit you find in hardware stores is sold in 10-foot lengths, and a 15 meter antenna will need to be around 11 feet long. Some method of lengthening the antenna will be needed. It could be done by attaching another foot of conduit to each end by using connector pieces for conduit.

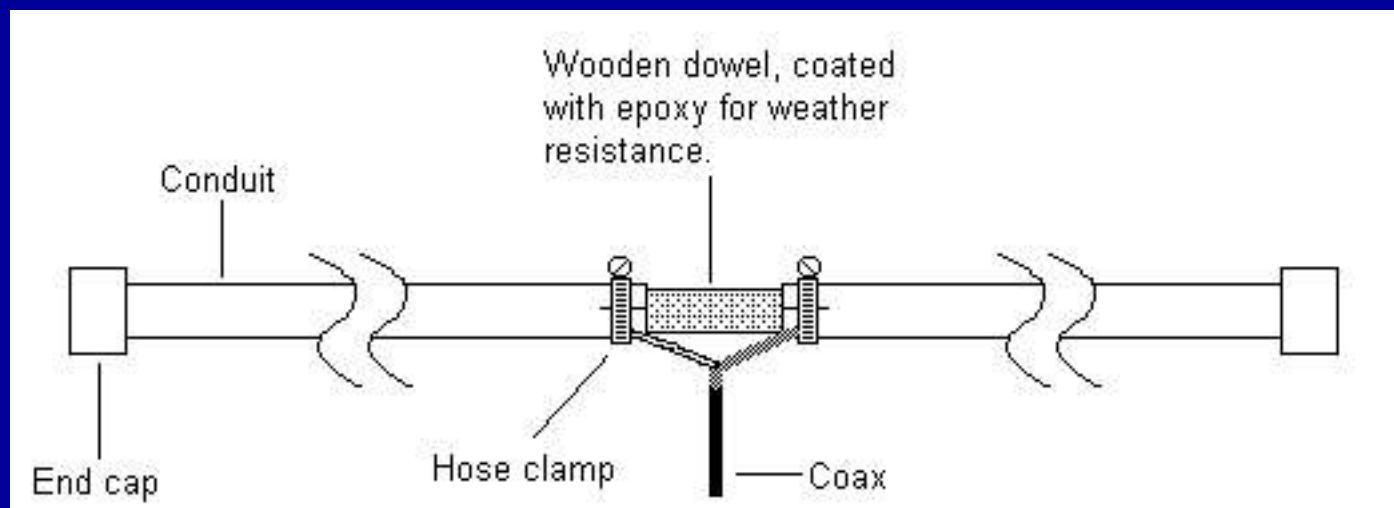

[Back](#) | [Home](#)

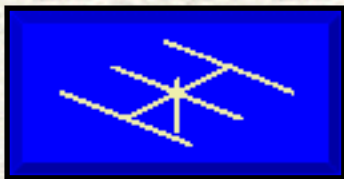

No. 26: When Should I Use a Vertical

on 10?



L. B. Cebik, W4RNL

Most of the antenna we have discussed in this column have been horizontally polarized. There are some good reasons for this fact. First, 10-meter horizontal antennas are fairly compact, with a half wavelength being about 16-17' long. Second, the shortness of a wavelength on 10 meters (35') generally simplifies the process of supporting a horizontal 10-meter antenna at a good height (at least 1/2 wavelength, with over 1 wavelength preferred for best performance). Third, even 3-element 10-meter Yagis are fairly light-weight, for easy support, even in field or hilltop operations.

Nevertheless, there are some good reasons for using a vertically polarized antenna on 10. Although the gain of such antennas may not usually compete with a well-installed horizontal antenna of the same size, this factor is rarely a problem when the band is open. So let's look at the question of when to use a vertical.

1. **Mobile in Motion:** The standard these days for mobile-in-motion operation is the short, center-loaded, magnetic mount vertical set on the car roof. Although the least efficient of almost any antenna used on 10, these antennas acquit themselves well. Full size 1/4 wavelength whips have gone out of vogue, especially with the increased use of plastics in autos. When auto bodies themselves become universally plastic or fiberglass, we may have to rethink the center-loaded mag-mount vertical for mobile operation.

2. **Lunch-Time Operation:** With small rigs, short antennas, and an open band around noon, 10-meter lunchers are more numerous than we imagine. Since the lunch hour (or half-hour) is all too brief, operators want a system that wastes no time in set-up and take-down. The vertical--again, usually a mag-mount antenna in the parking lot--fills the bill.

3. **Local Convention:** In some towns and cities, most of the locals may use vertical antennas. Sometimes, this represents a lot of mobile work; sometimes it represents former citizen's band operators who have joined the amateur ranks and cut down their old antennas to resonate on the higher frequencies. Since local work is mostly point-to-point, as in VHF operation, cross-polarized antennas result in major losses in signal strength. So if the local group is mostly vertical, then it will pay you to have a vertical at home

(as well as on the car) to join the fun full strength.

Since the path through the ionosphere generally skews signal polarization, distant stations will not suffer from being cross polarized relative to your antenna.

4. Lack of Space: Many hams live in homes without large yard. So space for antennas must compete for space with play equipment, patio furniture, and flower gardens. A vertical may be the only antenna type the home owner can erect.

The question here is not whether to use a vertical, but what kind of vertical to use. There are a number of multi-band verticals now on the market that will open many of the ham bands. They come in two major types.

If the roof top is the mounting area of choice, then one of the 1/4 wavelength trap verticals may be best. The heaviest part of the antenna is mounted near the roof top or chimney mounting system for maximum support. The necessary radials, installed according to the antenna makers instructions, can run along the roof top. If the antenna is at the end of the house, radials in the open direction can be run to trees or fence post, well out of reach of children or adults.

Where space is too restricted for an elevated radial system, one of the half-wavelength verticals may be more fitting. Some demand an elevated mounting point and may rest well on top of a fence post, short flag pole, or even a mast attached to a deck post. Other models call for ground mounting and can be placed in the most clear usable place in the yard with buried coax.

In all such installations, safety to children, family members, visitors, and neighbors is a top requirement. These antennas are rarely large enough to cause damage to neighboring property if they fall. Of course, they should be well clear of any utility lines crossing the yard. Finally, they should be isolated so that no one can get an RF burn by touching the antenna while in use. For some models, we achieve this last safety measure by elevating the antenna above reach, even by fence-climbers. Ground-mounted models require some extra thought. Setting up a flower bed and small fence around the antenna can keep most folks away. Sheathing the lower portion of the antenna in large-diameter black plastic down-spout drainage pipe for about 8' up is quite effective in preventing children from touching the antenna and has been found not to adversely affect performance. The protective sheathe can be attractively painted (with non-metallic paint) to call attention away from the antenna. Whatever the safety measures we take, we should also insure that they meet FCC requirements regarding RF exposure to other people.

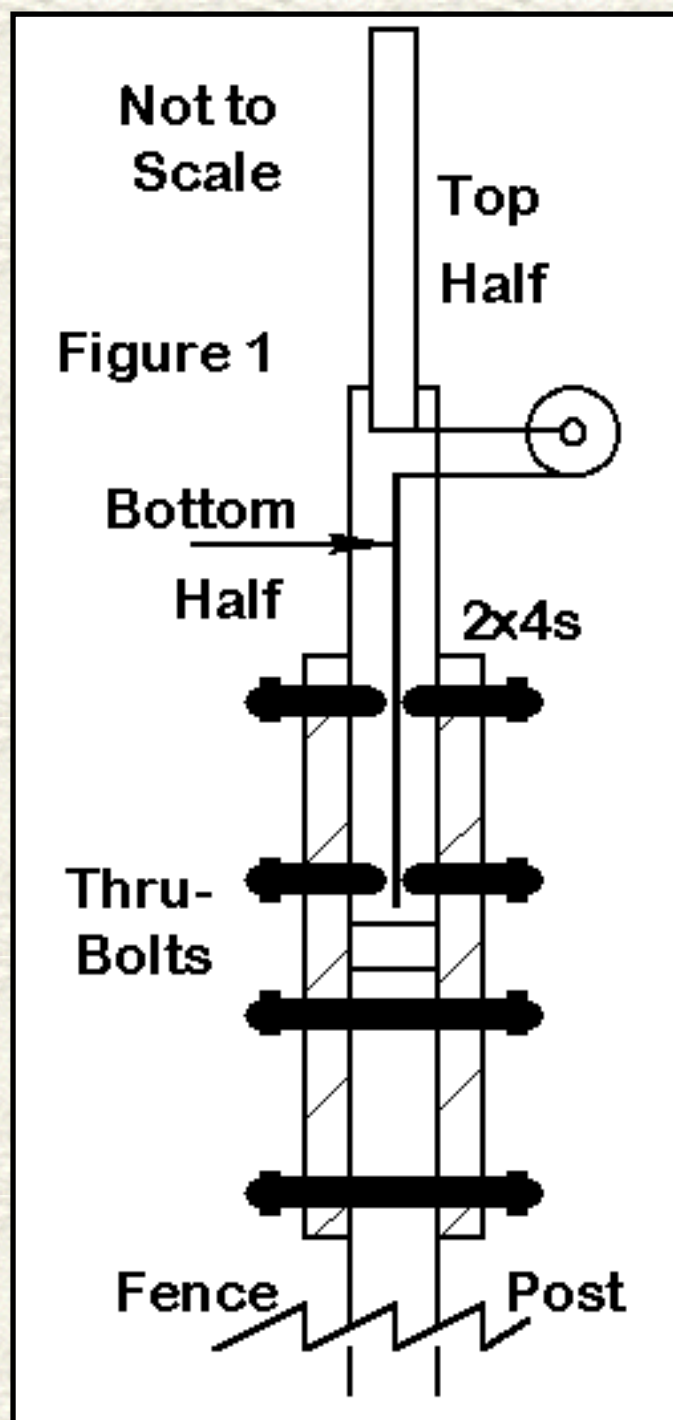

Even hams with room for a host of horizontally polarized antennas may wish to consider installing one of these multiband verticals. They make good (even if not great) low-band antennas, provide back-up service in case the main beams collapse in high winds or ice, and allow the operator to match the polarization of locals using mobile whips or other vertical antennas. So even if you can afford the highest, the biggest, and the best, one of these simpler antennas makes good sense as part of the antenna farm.

5. Home Brewers: Some of us like to build antennas. Some of us have to build antennas to save the cost of commercial versions. Whatever the reason, a vertical dipole for mounting at least 20 to 25 feet up at the center on a non-conducting mast is a good starter project. I suggest a vertical dipole, since it saves a lot of grief over where to run the radials for a quarter-wavelength ground-plane model. The vertical dipole also takes less space than a horizontal dipole and requires no turning for maximum signal.

You can construct a vertical dipole from hardware store materials: aluminum rod or tubing (a little over 8'), PVC, and wood are the main ingredients. **Figure 1** shows in bare outline a vertical dipole I once used to capture Worked All Continents in about an hour at the height of a long-ago sunspot cycle. The 4x4 fencepost was the main support, with underground bracing from bagged concrete. The side rail 10' 2x4s supported a good quality 2x4 mast, with the 4" side running between the rails. Two long galvanized bolts braced the mast. Removing the lower bolt permitted tilt-over operation.

The antenna itself began with an 8' length of aluminum tubing for the top extension. The lower part of the antenna consisted of insulated #12 house wire, purposely cut long. I tuned the antenna to frequency by trimming the lower wire for minimum SWR. Many local hams seemed initially horrified by the idea of a dipole made from unequal diameter elements and trimming only one end. They thought that terrible things would happen to performance, since the antenna was obviously as unbalanced as its builder.

Actually, virtually nothing happens except for a bit of building and adjusting convenience. Half-wavelength antennas lose nothing in performance by being fed slightly (or even radically) off-center. The feedpoint impedance does not begin to change noticeably until the feedpoint is well off center. The only

precaution was for safety: the dipole end is a high-voltage point on the antenna, so it had to be inaccessible to human touch when in operation.

There you have it: some good reasons for using vertical antennas on 10 meters, whether they are commercial multi-band antennas or home brew specials. There are other reasons of a specialized nature that we could add. For example, if you live by the seaside, expect an exceptional increase in performance over the same antenna placed on a rocky hillside in the Smoky Mountains. Verticals have proven to be more than good enough in some island contesting locations. Some operators even prefer the wider beamwidth of a vertically oriented Yagi to one that is horizontal. Whatever the reasons, verticals have and will always have an important place in 10-meter operation, even if we never mention FM and repeaters at all (which I just did).

Updated 1-12-2000. © L. B. Cebik, W4RNL. Data may be used for personal purposes, but may not be reproduced for publication in print or any other medium without permission of the author.



[Go to An-Ten-Ten-nas Page](#)



[Return to Amateur Radio Page](#)

The W5QJR Antenna Revisited

By Richard Morrow, K5CNF

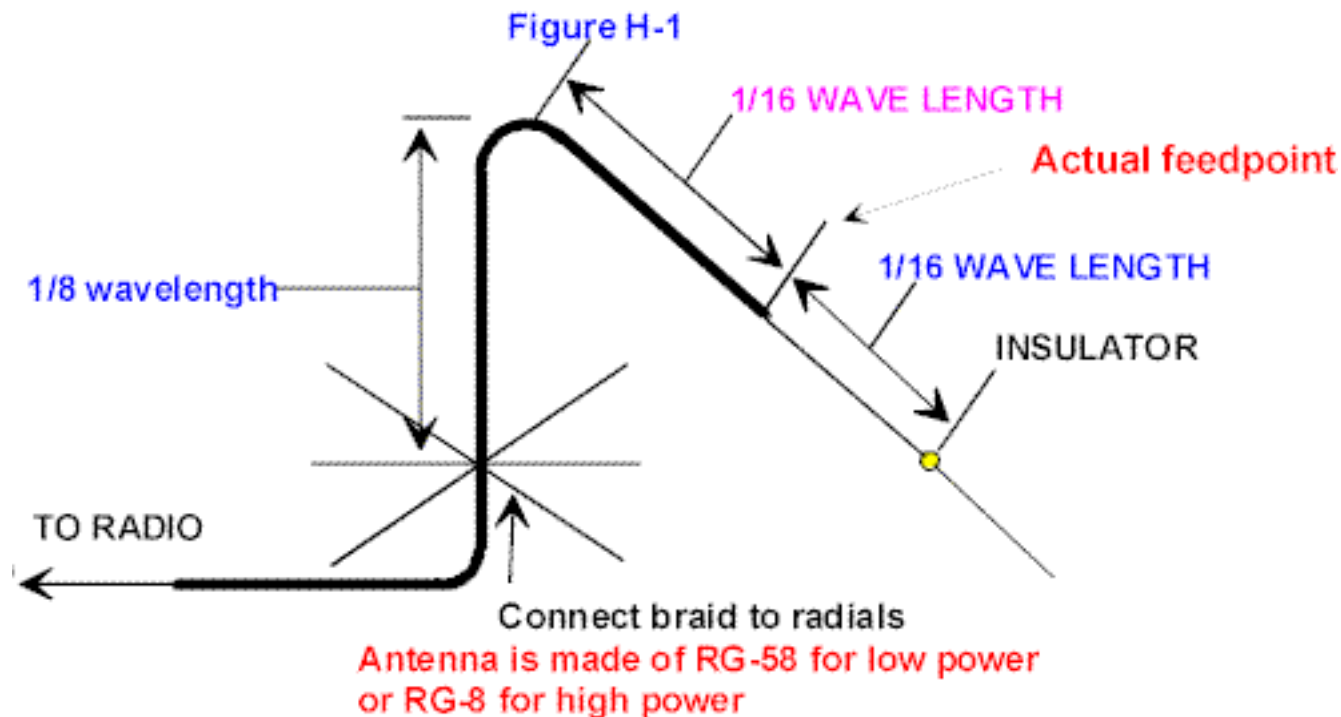

Back in October 1989, the entire paper magazine issue of *antennex* was dedicated to a new antenna concept that engineer/inventor, Ted Hart, W5QJR had come up with in the course of trying to develop a good feed method for his tower on 160 meters. In the process he came up with the antenna that is depicted in Figure H-1. This rather odd looking antenna is a very interesting antenna in that it worked when it was taped to the leg of his existing tower. If it was tuned up there or if it was strung up with an insulating support, it worked just as well. But, an existing tower isn't essential—a tree or similar support will do fine. Here's how Ted's article introduction describes the concept:

"A short wire can be added to an existing tower (or hung from a tree) to form an excellent low band antenna. This antenna *combines* the features of a horizontal and a vertical antenna to provide constant signal level to all stations from *near-in to more than 1,000 miles*. It is the optimum antenna for rag chewing and net operation on 40, 80 and 160 meters. It is also an excellent DX antenna."

RUNS LOW POWER

So I put one up for 75 meters that was only 32 ft. (9.75 meters) tall. To say it worked is mild. I was only running about 15 watts out and got some reports that were far better than I would have imagined. No one believed I was running so little power. A report of 20 over 9 from Los Angeles was the first one I got—then a 30 over from Atlanta, followed by a 25 over from Cuba was enough to convince me that this antenna worked. No only did I get these good reports, I could hear Ted, who lived in Melbourne, Florida, which is about 1,100 miles due east from me across the Gulf of Mexico. He was working into Europe

and making contacts in just about every country east of Moscow. Ted had only a TS-440 on the air, running 100 watts and he was getting good reports. Also, I could hear the stations he was talking to, but could not break into the pileups due to my low power. Moreover, I had a rather large amount of power lines, telephone cables and other utility lines surrounding my antenna. These lines were to the East of my antenna and also very close to the antenna. I am sure that these multiple conductors had a definite effect on my signal in that direction.

SIMPLE CONSTRUCTION

The interesting thing about this is that the antenna was hung from a 35 ft. (10.67 meters) pole held up by a 20 foot (6.10 meter) redwood pole. There was no problem tuning up the antenna, and it worked as long as I had it up. The construction of the antenna is simple and well described in the October, 1989 issue, which is in the Library archives. This antenna is well qualified to be a disguised antenna, since it is so short for the lower frequencies—32 ft.(9.75 meters) for 75 meters, 16 ft (4.87 meters) for 40 meters, and the size goes down from there. An interesting feature is that the folded-over portion of the antenna can be straightened out and extended straight up after going up in frequency past 20 meters. The folded part of the antenna adds a horizontal component to the radiated signal, which enables you to make more reliable contacts in closer than a pure vertical antenna would. This is due to the horizontal and vertical mixture of radiated energy giving higher angle radiation to the signal, yet enough vertical radiation for DX work.

REALLY DISGUISED

This is a very unusual antenna, indeed. It can be put up easily and tuning is not that difficult either. It does work and work well. I have no explanations other than it is another of these antennas that came into being by accident. A very pleasant accident as well, I might add. One thing that is also interesting is that it does not look like an antenna, which adds to the disguisability of the antenna.

Another experimenter who put one of these antennas up was G6RJ, Rob. He had very good results working into the Far East with excellent reports via long path on 18 MHz. For those who are interested, there is several ways to make these antennas directional and if enough interest is expressed, we will put more about this in a future issue.

For now, if you are interested in this antenna, go to the Library under Past Articles and look at the article "The W5QJR Antenna-Revolutionary Concept!" and all of the basics and tuning information will be there and get you on your way to putting up one of these antennas. Many folks have reported finding this to be a very interesting concept and solves some unique problems. **-30-**

Send mail to webmaster@antennex.com with questions or comments about this web site.

Copyright © 1988-2000 All rights reserved worldwide - *antenneX*©

Last modified: April 01, 2001

802.11b Homebrew WiFi Antenna Shootout - 2/14/2

Update 11/2/2003
Added notice at bottom

Update 2/16/2:
I've been [Slashdotted!](#)
Some grammatical/spelling errors corrected

Update 2/21/2
[How To](#) finished, linked.

- [Introduction](#)
- [What the huh?](#)
- [The Shootout](#)
- [Performance Summary](#)
- [The How To](#)

Greg's obsession de' jour

In my efforts to add the words "wireless savvy" to my network admin resume, I've been reading books and web pages on radio propagation, antenna theory and design, and building wireless networks with 802.11 (WiFi). One of the first things that got me excited was the [Pringles Can Antenna](#). Published on the internet and in a [fine book](#) by [Rob Flickenger](#), the net admin for [O'Reilly](#), this design for a do-it-yourself, VERY inexpensive antenna made from a recycled junkfood container is as cool as the other side of the pillow. It seems that everyone is building and using these. The various community wireless network groups all talk about them and [folks are reporting that they do the job](#).



A friend of mine built his before me and looking at his finished antenna got me excited to understand the theory of how it works. Reviewing his plan, I came up with different spacing that he Rob did. To see if I could improve upon the design, I built mine with corrected spacing. While waiting for some wireless equipment to come in, I started looking for my next antenna project. Oddly, the more I studied, the less I understood. There seems to be quite a bit of confusion on how the Pringles antenna works and what design category it falls under. The inner lining of a Pringles can looks metallic, but my tests show it not to be. The Pringles Antenna design, and some designs that pre-date it, seem to treat it as though it were metallic. While folks are calling it a Yagi-Uda style antenna, the design of the driven element in the Pringles can antenna looks like a Waveguide style design.

Waveguide antennas don't use the director assembly (the washery bits), and therefore are much simpler to build. An old tin can of the right size, about \$5 in parts and 10 minutes of time are all that are needed. The math for computing correct sizing of the components in a waveguide WiFi antenna is simple. Formulas in hand, I started searching my cupboards for tin cans that fit the spec. I found myself staring at the products on the canned food aisle at the grocery store. I even went so far as going grocery shopping with a tape measure. "No no, this spaghetti sauce looks much better. It's about three quarters of a wavelength in diameter, hon!"



What the huh?



On Feb 11th, Rob, posted an [article on his newest homebrew WiFi antenna](#) - a tin can waveguide! Rob used a large, 39oz. coffee can and placed a quarter wavelength driven element a quarter wavelength from the back of the can. He reported good results - even better than the Pringles can design used by so many. For the antennas I was building, I was using different measurements based on the antenna design material I had been reading. Now I'm a late entry into this wireless stuff and the experts are going a different way than me. It's time to benchmark.

The Shootout

My plan was to get relative performance measurements for various designs (including mine) of homebrew antennas for 802.11b (WiFi) wireless networks. To do this, I setup a wireless link and changed only the antenna- recording each antennas' performance under identical conditions. I didn't compare them to a commercial directional antenna as my only one has a male connector and I don't have

the right cable to hook it up yet. The contestants were (click on each for design specifications).

- [A commercial Lucent "range extender" omni directional](#)
- [A buddy's Flickenger-design Pringles can Yagi](#)
- [My modified design Pringles can](#)
- [A Flickenger design coffee can waveguide](#)
- [A coffee can waveguide with corrected radiator placement](#)
- [A Hunts 26.5oz. pasta sauce can waveguide that fell in the optimum size range](#)
- [A Nalley 40oz. "Big Chunk" beef stew can Waveguide](#)



Performance numbers and methodology

The Performance Summary

The results surprised me! In our test, the Flickenger Pringles can did a little better than my modified Pringles design. Both did no better than the Lucent omnidirectional. Now this is just on raw signal strength, noise rejection due to directivity still makes a directional antenna a better choice for some uses even if there is no gain benefit. The waveguides all soundly trounced the Pringles can designs. I mean they stomped them into the ground on signal strength - as much as 9 dBm better. Every three dB is a doubling in power - that's three doublings (8x increase)!

Of the waveguides, the Nalley's "Big Chunk" took top marks. It was followed by the Hunts Pasta Sauce, my modified coffee can, and the Flickenger coffee can in that order. My three waveguide designs, which utilized the correct theoretical spacing, out performed the Flickenger Yuban coffee can handily. It seems that the design formulas for the waveguide design made a sizeable difference in performance. In the yagis, it didn't matter much. This could be because neither Rob's nor my designs are anywhere near right for optimum performance for a Yagi. I've decided that Yagi design is not for the timid or non-radio-expert.

With these results, I'm convinced that the waveguide design is the way to go for cheap wireless networking. The performance is good, the cost is very low and the skill required is minimal. If you can eat a big can of stew, you can make a high performance antenna.

The How To

[Build your own Tin Can Waveguide WiFi Antenna](#) (Cantenna). It's the easiest antenna design I know of.

Copyright 2003-2004 Gregory Rehm - All rights reserved.
For information about reproducing this article in any format,
contact the author: greg@turnpoint.net

WINDOM ANTENNA

I'm using homebrew Windom-Antenna recently.

In the total length of this antenna is 41m, height is about 11m, and diameter of element is 2mm.

However, it is up only about 4m height from a metallic roof.

I modified this antenna originally used as Inverted-V type of 80m band Dipole a little.

The feeding point of this antenna is located 13.6m from the edge of Element. Yes, it is **Off-Centered**.

BALUN of making which uses two cores, converts impedance into 1/4. The core is the one of about 4cm in the diameter. so there's no problem in the input power 100W at all. Because two cores are used, I think as much as 500W safe in power.

The diameter of the wire rolled in the core is about 1mm.

The VSWR to frequency is shown as follows.

| Freq. | VSWR | Freq. | VSWR | Freq. | VSWR | Freq. | VSWR |
|-------|------|--------|------|--------|------|--------|------|
| 3.525 | 1.1 | 14.050 | 1.8 | 18.070 | 3 | 28.150 | 2.5 |
| 3.570 | 1.4 | 14.100 | 1.7 | 18.160 | 3 | 28.500 | 2.0 |
| 3.795 | 1.6 | 14.150 | 1.6 | 21.050 | >3 | 29.000 | 1.3 |
| 7.030 | 1.4 | 14.200 | 1.3 | 21.449 | >3 | 29.300 | 1.1 |
| 7.060 | 1.3 | 14.349 | 1.2 | - | - | 29.600 | 1.2 |
| 7.099 | 1.2 | - | - | - | - | 29.699 | 1.3 |

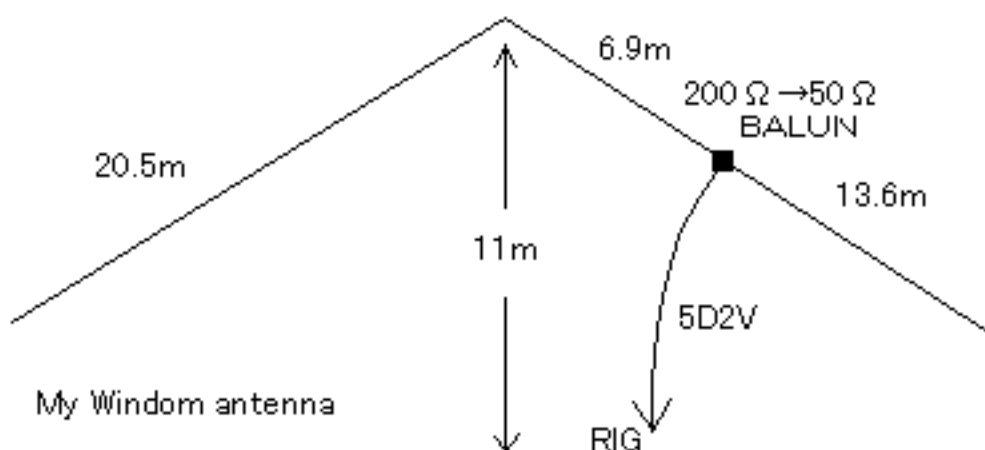

In 21MHz, VSWR exceeds 3. However it is likely to QSO with the domestic area, if Antenna-Tuner is used. I did not obtain good results though I measured its VSWR with 10MHz and 24MHz besides <showing up>.

I think this easy

structural wire antenna is Very FB. Because I can QRV on multi BANDs without switching some antennas.

By the way, I had one question. This antenna might be a name of "Windom" why?...

I thought it might designer's name or name of a place of development ground.

The answer's as following e-mails via radio-amateur's FWD-Net.

Dear friend, i have a self building Windom; it is a dipole of 80 meter with the connection at 1/3 of the lenght: in this point the impedance is 300 ohm, and with a balun 1:3 i obtain 50 ohm; for the band of the 21 Mhz i put a second dipole only for this band, connected ad the same mode of the other; the lenght of this is 2.3 + 4.6 meters.

In a test with a vertical groun plane 5 band, the windom result better in 14 7 3.5 Mhz; using a good antenna adapter, it can be used in 1.8 Mhz.

This antenna is named Windom because was bilded from Laurent Windom (W4DZZ ?) around the 1930.

It' s not a long time that i use this antenna and i have some thing to understand about it; in any way i'm really satisfate from this antenna.

I wish to you to have big satisfation using them.

Best 73 an good DX. Ciao de **Franco. IK1OWB@IK1JNS.IPIE.ITA.EU**

Hello Tada !

The "Windom Antenna" was described by Loren G. Windom (QST, Sep 1929, pp 19-22, 84) so this kind of antenna was named after its inventor.

73 / **Peter, DJ2ZS@db0gv.#hes.dl.eu**

The windom is called after its inventor.

Here I use a windom antenna on 80 - 10 m. the ntenna is 41 meter long.

13% off center I feed it with 300-ohm open air-spaced feeder. I use an antenna tuner with the balun coin connected to the antenna tuner. The antenna hangs in zig-zag between some trees. I am very pleased with it, it works quite well locally and on DX. Thought this might be of interest to you..

Good luck!

73 de **Egil. LA8HF@LA4O.OSL.A.NOR.EU**

Thanks to Franco, Peter and Egil. Best regards to you.

And thanks for more infos via the Internet. Those are ...

I just read an interesting article in Czech ham radio magazine "AMA".

The article itself was about history of the bobtail curtain antenna, but there was an interesting note: Loren Windom first described this antenna, but he himself said that it was invented by someone else as a modification of Hertz antenna.

I found some people to call the coax fed antenna with a balun "FD4" - but some other people call FD4 the modification mentioned by Franco IK1OWB (but the measures are doubled: 9.4+4.7 meters).

73 **Jindra OK1FOU**

Regarding the Windom, I have a long time experience with such an antenna. I designed mine in 1978. It is different from the "normal" ones because I use a different type of balun and this, from my point of view, is superior to the toroid one because the core does not saturate with high power or reactive loads.

From my point of view, this type of antenna is not rightly called "Windom", it should be called, probably, Long wire off center fed antenna.

The reason is very simple; the Windom antenna was referenced to ground as the feed point was between an off-center side point and ground.

The modern type of "Windom" Antennas are off center fed but not referred to ground. The validity of calling them Windom is due to the idea of "off-center feed".

73 **Gian I7SWX**

The windom antenna should never be configured as an Interted Vee but should be Flat Top as it was originately.

Matching network such as the Johnson Viking Matchbox is highly recommended

if fed all the way with 300 ohms line.

This antenna is suitable for all traditionnal ham bands.

73 from **Cam. VE2SO**

O-kay, Definitely maybe, it should not be called "Windom" that is not single-wire fed or flat-top.

But I will call the antenna for multiband "**Windom**" in high regard.

Well, that is as same as a relation between **H-Hentenna** and Hentenna. You know Hentenna, don't you? Hentenna is a kind of Loop antenna, but H-Hentenna is not loop.

Anyway, **H-Hentenna, that is one of variation of single-wire fed Windom (or 8JK)**. It was developed by **JR1FTE** and expanded by **JA7KPI** in 1982. For more infos, see the **LINKs below**.

[BACK to SHACK & FIELDS of JA7KPI](#) | [H-Hentenna for 14MHz](#) | [H-Hentenna for 50MHz](#)

[BACK to FRONT PAGE](#)



"Home of the RASCAL"

My Favorite Multi-Band Antenna

The "WINDOM"

By G. E. "Buck" Rogers Sr; K4ABT

In September of 1949, I was tired of climbing poles and trees to move, remove, add, or change my single-band HF antenna's. In those younger years of my HAM radio hobby, I had used single band dipoles and doublets for almost every HF Amateur band. I had tried long-wires, doublets, dipoles, and Zepps, but again, operation was restricted to single band operation, maybe two bands at most.

I had heard of the "Windom" and read a few articles about the Windom, but most of my thoughts were ... ho-hum.. just another dipole fed a bit off-center. Then one evening at a meeting of the GARC in the old "Sea Scouts" club house near the Coosa River in Gadsden, Alabama; I heard some of my "elmers" Gilbert Watson (SK) W4PAC, Gale Caudle (then W4CFB), Jack Kennamer (SK) W4YPC, Bob Bynum W4USM, Austin (Vic) Vickery, Walter Damkohler (SK) W4EBO, W4CWF, Ed Elkins (SK) W4CDI, Homer Dupree (SK) W4OZK, Jim Runyan, Homer O'Dell, Robert Martin, and others discussing the Windom *all-band HF antenna*. It was when Jack (W4YPC), mentioned ***using one (Windom) antenna, on the all HF bands that my ears went directional!***

That last phrase caught my undivided attention. "most all HF bands,etc"
What! *A multi-band HF antenna* ? Surely I had been blessed.

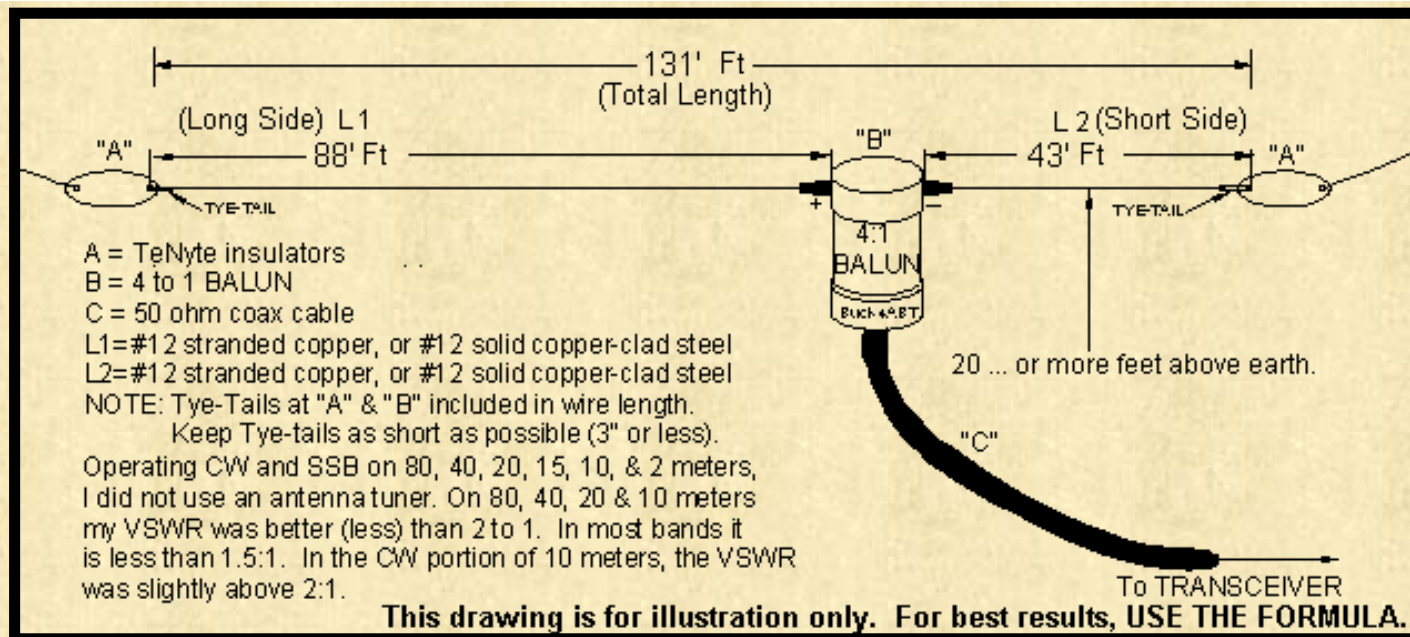

To think that I could put up a Windom, and no longer have to climb the poles and trees to hang another (single band) HF antenna was great news to me. To be able to use it without an antenna tuner was icing-on-the-cake. For a kid without extra funds, an antenna tuner was a luxury that I could *not* afford. Even my transmitter was a single 807 rig I homebrewed on an old *Atwater-Kent* radio chassis, my grand-father had given me.

In those days, a BALUN was unheard of. My Elmer's described, a means of connecting the coax to the off-center fed antenna using a nine (9) turn coil of the coax feed-line at the feed point. This coil of feedline coax formed a "de-coupling" loop. The de-coupling loop provided a crude means of matching the feed coax to the antenna, and at the same time, it would reduce the "re-radiation" (RF currents) along the outside (shield) of the feeder coax.

Today we have toroid cores and BALUN devices that provide a more efficient means of coupling RF energy to the antenna (reducing the VSWR, "standing-waves"), while performing better impedance matching. In the drawing shown above, I've drawn the exact dimensions of the Windom I built in 1949. The only differences in my Windom of 1949 and today are:

- 1) the material the insulators are made of, and
- 2) I've substituted a 4 to 1 BALUN for the 9 turn, 8 inch diameter, decoupling loop.

AN UPDATE:

Since writing this article a few decades ago for a major HAM radio magazine, I've received tons of mail (and eMail) asking for more information, especially with regards to a 160 meter version; Here then is "the rest of the story."

First of all, we'll address the formula, and how to determine the length(s) of each section, using the same old formula that I used in 1949.

Long side.... = 468, divided by the frequency, then multiply by .64 (= Feet)

Short side.... = 468, divided by the frequency, then multiply by .36 (= Feet)

THUS; for 160 thru 10 Mtrs.....

Long Section; 468/1.8 MHz = 260 x .64 = 166.4 feet.

Short Section; 468/1.8 MHz = 260 x .36 = 93.6 feet.

For 75 thru 10 meters do similar math to arrive at/near the dimensions shown in the drawing below, but for best results, use the formula.

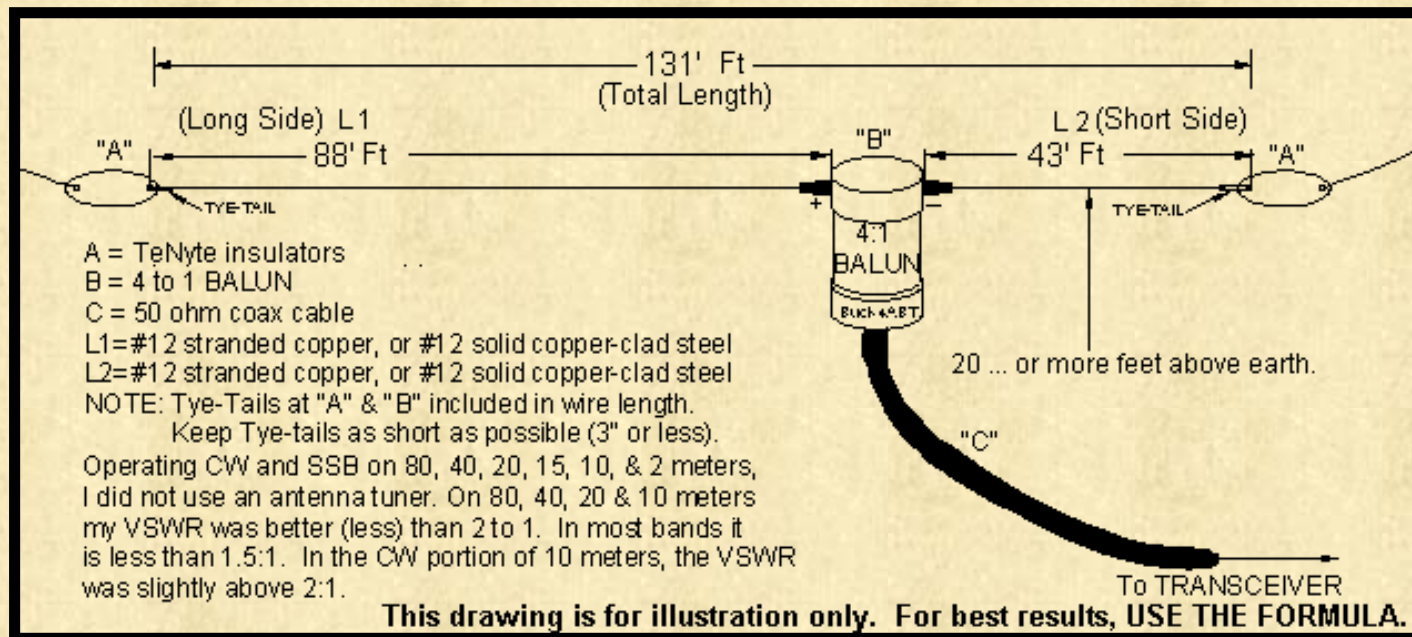

The Windom can be installed as an inverted VEE, or as a sloper, **but in no case**, should the angle be less than 90 degrees against itself. *To use an angle that folds against the pattern of the opposite end of the Windom, would change the impedance of the feed-point, change the multi-band features, and most important, destroy the radiation characteristics of the antenna.*

In other words, install the Windom as you would any other dipole, while using a common sense approach. The fact that we are feeding

this Windom using coax, and a single balun, gives us the ability to construct it as an inverted VEE or at a "real estate saving (angle)" without destroying the features and performance of the Windom.

This is *not* true with those antennas fed with ladder-lines and those that have several impedance transitions built into the feeders

of the "basic" Windom..... There's more to come, so read on!

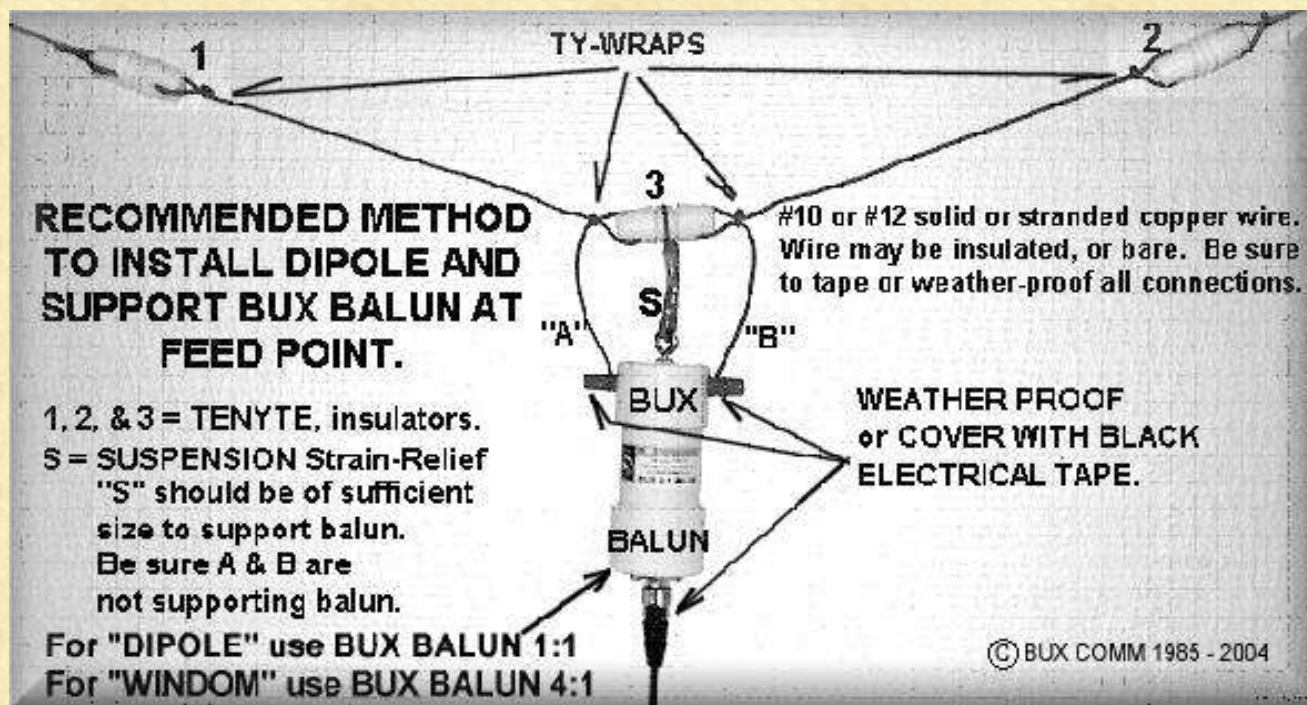

ANTENNA INSULATORS

Weatherproof, (TENYTE) insulators. Perfect for your DIPOLE or Windom antenna.



For the apartment dweller, you can now hang the 20 meter doublet in the attic. I've QSO'd with stations all over the world with the 33 ft dipole in my garage attic. One insulator at the center, and one each end.

It's great for other HF [WINDOM](#) and single-band dipole antennas. Dielectric strength is comparable to the old ceramic insulators, without susceptibility to cracking or breakage under impact or extreme temperature changes.

Package of 3, \$2.99 ANTINSL3

[Order Now](#)

Package of 10, TeNyte Insulators \$8.99, ANTINSLX10

[Order Now](#)

Now it's time for me to P O the wire and cable vendors, and the proponents of Windom's with too many feed-line transitions. Twin Lead, Ladder-line, Window Line..... etc.. is an over-kill.. The trade-off is not...; I repeat; NOT... worth the pain and upkeep to replace it every year or two.

And trust me... It is NOT a problem of the ladder-line insulation quality or properties that I'm speaking of. I speak from experience; Wind will destroy ladder/twin-lead line. Even the robust type will succumb to the wind element in time.

IF; you decide to use ladder line, make one turn (twist) to each 20 to 24 inches of line to decrease the wind resistance presented by the "flat" line..... even if it is "window-slotted" type ladder-line. By adding the one twist per 20 inches, it may last longer than three years.

COAX does NOT present a high degree of wind resistance, and it'll last much longer.

Having *been there, done that*, and heard similar horror stories from others; another question arises regarding parallel line currents that come with the use of so-called balanced (twin-lead) feed-lines. To add injury to the ladder-line proposition, the balanced line may also assume the properties of a *single wire feeder (yuk)*.

Some purveyors of the Windom that use ladder-line transitions, must use two impedance matchers (or BALUNS) with their (knock-off) Windom. One is to transition the coax outside the HAM shack (*heaven forbid, we use ladder-line inside the shack... RF "feedback" in everything*), to the ladder line, then another at the Windom (antenna) feed-point to choke off parallel current from the ladder-line.

Since the feed point of this antenna has been found to be near 220 to 260 ohms, *the use of a 4:1 BALUN to join our coax to the antenna*, emerges as a compromising solution.

Let's not lose sight of the most important advantage of using this antenna; and that is: It provides us with a powerful, multi-band antenna, and a minimum of feedline components.

Now for the "perfectionists" among us, if you want to smooth out the hills and valleys on some of the bands, add your antenna tuner to the system, and the Windom becomes very flat across the bands. When I say "flat," we are talking about reducing the VSWR to a minimum, to produce a good forward power, transfer of RF energy to the Windom.

We're having fun already... with the Real WINDOM antenna



The "Windom Antenna" was described by Loren G. Windom in QST magazine, September 1929. Pages 19 through 22. It is named after its inventor/designer.

Loren Windom, W8GZ, was first to reveal the antenna to the radio amateur community by describing the antenna in the September 1929 issue of QST. It was by Windom's name that the antenna became known. The Windom antenna is an off-center fed dipole with an unbalanced coax feedline.

In 1937, the Windom was first described as a compromise multiband antenna. The antenna can be employed on 80, 40, 20 and 10m with considerable, though acceptable levels of VSWR. What became perhaps the most popular multiband Windom design of all, was the German-made Fritzel FD4 antenna, described by the late Dr. Fritz Spillner1, DJ2KY, in 1971. It had the same dimensions as the multiband Windom antenna, but fitted with a 200Ω (4:1) balun in its feedpoint and fed with coax.

Today, many radio amateurs are using multiband Windom antennas with more than satisfactory results. It would not be without reason that Windom antennas are being employed during IARU HF World Championships! and most of all, by "high-stake-contests." **Perhaps many young hams ignore the multiband Windom antenna because of its sheer simplicity and may be thinking it is too good to be true.** The complexity of feeding other dipoles and doublets, the losses in dipoles with traps and the esoteric marketing of some other antennas seem to appeal to them more.

[CLICK HERE: and read more about the evolution of the WINDOM, to ZEPP, to VHF J-POLE.](#)

BUX BALUNs should be installed at the antenna feed point, or where the coax or feed-line attaches to the above ground antenna.

BUX BALUNs are used to connect balanced antennas to unbalanced transmission lines, such as coax cable. Their primary purpose is to prevent antenna (RF) currents from flowing down the outside of the cable. Another function of the BUX BALUN41 is to match the impedance of an unbalanced coax to the balanced feed point of a balanced input antenna(s). BUX BALUNs may also be used as "line isolators" anywhere along the cable to prevent the destructive influence of induced RF currents (VSWR).

BUX 1:1 BALUNs are current BALUNs. They consist of several large, number 73, ferrite type 44 cores. **BUX BALUN11** operate from 3.5 to 72 MHz and allow use of RF power to the rated capacity of the BALUN.

BUX 4:1 BALUNs are voltage BALUNs. They consist of a large, number 41, ferrite dough-nut bobbin. **BUX BALUN41** operate from 3.5 to 55 MHz and allow use of RF power to the rated capacity of the BALUN.



During this month, when you purchase either of our BUX BALUNs, we will include 3 (Tenyte™), insulators FREE. A \$2.99 value. Be sure too mention this offer in

the "Comments" space on the order form check-out page!

At BUX COMM, *We don't cut corners!

The components used in the manufacture of our BALUNs are from top quality components, beginning with the Silver Plate SO239 connectors and center insulator is made of teflon™(E.I Dupont). The wire we use to wind the ferrite donut is heavy-duty, silver flashed wire, with teflon™ insulation that will handle RF voltages above 5000 volts, and temperatures above 2000 degrees. The binding posts are heavy-duty, tempered brass, with end holes and side-thru holes to accommodate either type loop-thru connection. A double-shoulder brass capture nut is used to add a secure bite and improve antenna wire electrical connections. With our BUX UN UN (ONION), the coax is Belden™ and the PL259 connectors are Amphenol™.



4:1 Balun, BUXBALUN 41 \$19.95

[Order Now](#)

- o 50 ohm, SO-239 unbalanced input
- o Balanced output
- o 1.6 to 50 MHz
- o Toroid (Voltage) design
- o Heavy Duty, Lightweight construction
- o Sealed against moisture

1:1 Balun, BUXBALUN 11 \$19.95

[Order Now](#)

- o 50 ohm, SO-239 unbalanced input
- o Balanced output
- o 1.6 to 50 MHz
- o Toroid (Current) design
- o Heavy Duty, Lightweight construction
- o Sealed against moisture

BUX UN UN De-Coupling transformer, similar to above, but has SO-239 (female) input connector and output connector is 1 ft Mini 8 cable with PL-259 (male).

BUX ONION \$19.95

[Order Now](#)

4:1, 1.5kw Balun, BUX BALUN 41HD \$27.95

[Add To Cart](#)

Toroid design, wound with teflon covered, silver plated wire.* Heavy-Duty, construction.

1:1, 1.5kw Balun, BUX BALUN 11HD \$27.95

[Add To Cart](#)

Toroid design, wound with teflon covered, silver plated wire.* Heavy-Duty, construction.

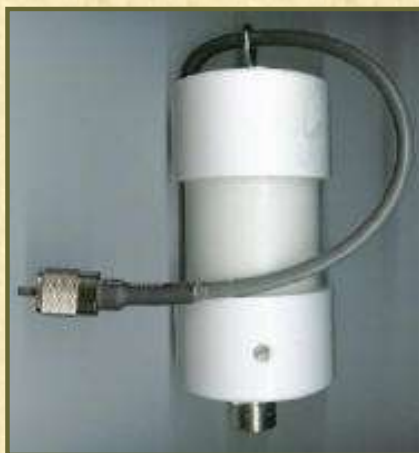

BUX ONION Decoupling Transformer

BUX UN UN De-Coupling transformer, has SO-239 (female) input connector and output connector is 1 ft Mini 8 cable with PL-259 (male).

BUX ONION is an UNbalanced to UNbalance (UN-UN) *decoupling transformer* designed to be used specifically with [the DBLSPCL antenna](#).

High RF currents traveling along the coax feed-line shield can cause high VSWR. This decoupling transformer prevents RF currents from traveling down the outer shield of the coax.

The input connector is an SO239 (female) and the output connector is a PL259 (male), which mates the connector of the "DBLSPCL" RV/Apartment dweller antenna shown above.

BUX ONION \$19.95

Order Now 

WHY USE A **4:1 BALUN**

Krusty Olde Kurt is now going to repeat himself. Why? Because the same question keeps coming up over and over. And he wants everyone to get it right.

"I'm feeding my dipole with 600-ohm line. At the station end I need a balun to convert to 50-ohm coax. I need a 12:1 balun, right?"
Wrong! A 4:1 balun would be better.

Why is that? If your dipole is up, let's say, 35 feet then on 80 meters it will probably have a resistance at resonance of about 40 ohms. The actual resistance depends on the height above ground in wavelengths.

If the dipole is 40 Ohms then what do you see at the transmitter end of your 600 ohm line? If the line is a half-wave long (120 ft on 80 Meters) you'll see 40 ohms. Remember, a half-wave line repeats what it sees at the other end. But if it is a quarter-wave long you'll see 8500 Ohms! At other line lengths you'll see impedances somewhere between these two extremes.

So you are not going to see 600 ohms at the end of your 600-ohm line. That only happens if you have a 600-ohm antenna hooked onto it. With such a variation in impedance at the transmitter end of the line there is no one balun transformer that will match it. Most of the time the impedance will be above the 50 Ohms of your coax so a high impedance balun would be desirable. Unfortunately high impedance baluns don't work well when not matched.

Experience has shown that **4:1 baluns work best** in this service. They are more rugged and will take bad mismatches especially if they are wound on an iron powder core. So stop searching for that 12:1 balun. **Use a 4:1 BALUN and your system will work just fine.**

You can read Kurt N. Sterba "AERIALS" column in **World Radio Magazine**.



BUX MOBALUN

When you hear those strong HF mobile signals, here's one reason they stand out from the rest. By installing the BUX MoBalun near the input to your antenna, you deliver more RF energy to the antenna. At the same time, the BUX MoBalun prevents RF from traveling back along the shield (high SWR) of your coax. High power rating, Low-permeability toroid, with Internal composition fiber-glass to prevent vibration during mobile operation. For input and output connectors, we use only the best Silver plated, Teflon insulated, SO239 connectors. 700 watts PEP. Our **MoBALUN** is also ideal for marine antenna installations.

\$19.95 MOBALUN

[Order Now](#) 

ANTENNA INSULATORS

Weatherproof, (TENYTE) insulators. Perfect for your DIPOLE or Windom antenna.



For the apartment dweller, you can now hang the 20 meter doublet in the attic. I've QSO'd with stations all over the world with the 33 ft dipole in my garage attic. One insulator at the center, and one each end.

It's great for other HF **WINDOM** and single-band dipole antennas. Dielectric strength is comparable to the old ceramic insulators, without susceptibility to cracking or breakage under impact or extreme temperature changes.

Package of 3, \$2.99 ANTINSL3

[Order Now](#) 

Package of 10, Insulators \$8.99, ANTINSLX10

[Order Now](#) 

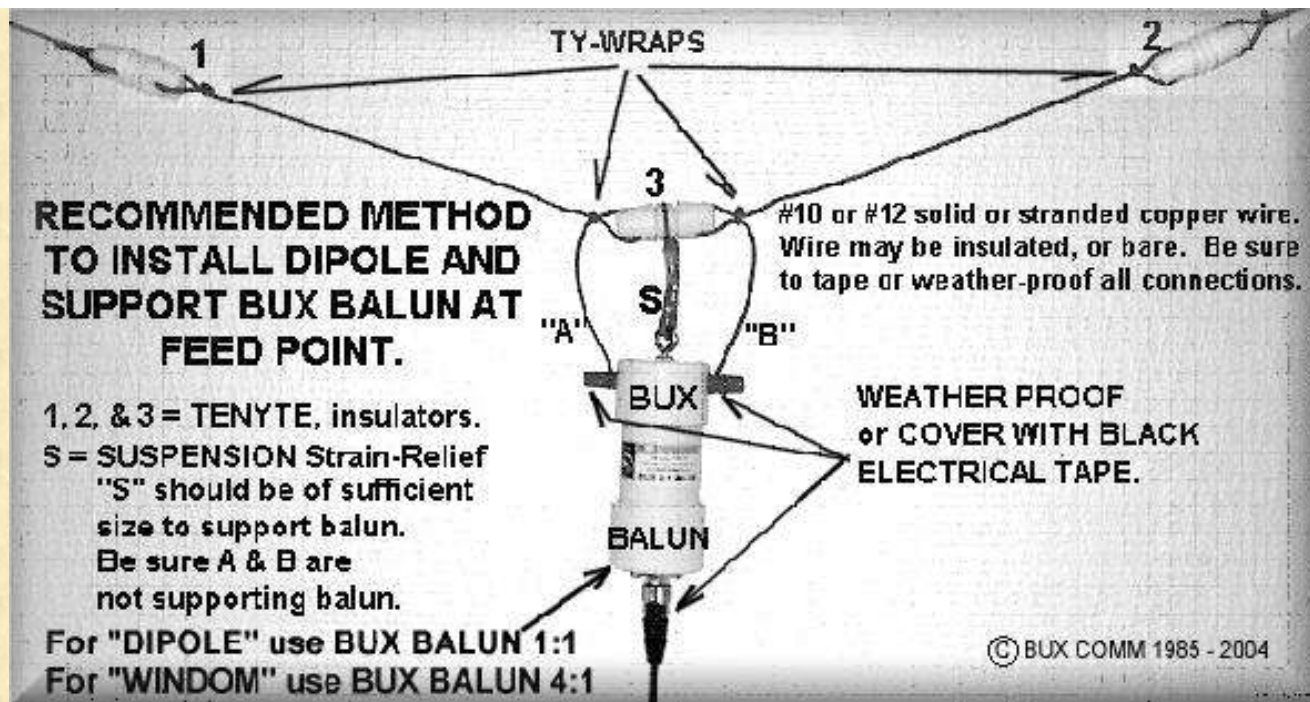

UHF DOUBLE FEMALE BULKHEAD (feed-thru) CONNECTORS

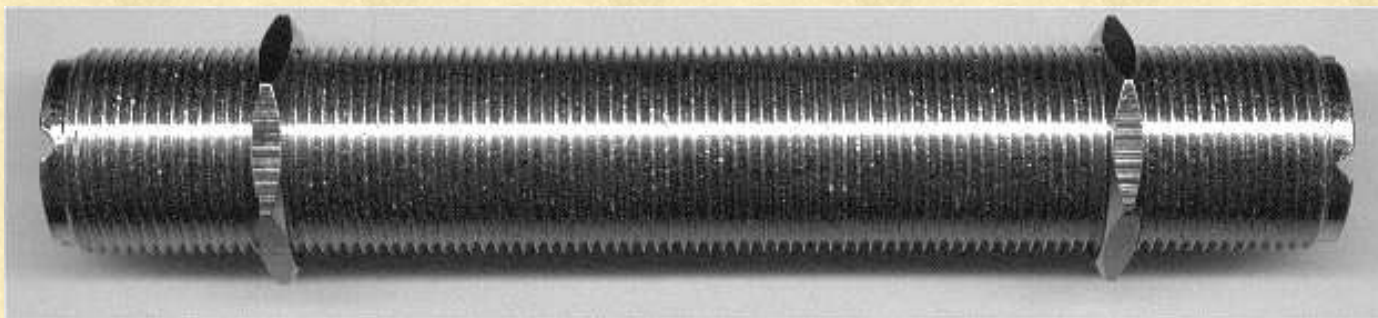

For bulkhead and through-the-wall UHF connector feed-thru connections, with keeper nuts.:

Order 7518-2 (Two inches)

\$ 2.95 ea.

[Order Now](#)

10 for \$ 24.50

[Order Now](#)

Order 7518-4 (Four inches)

\$ 3.95 ea.

[Order Now](#)

10 for \$ 34.50

[Order Now](#)

| | | | | |
|-------------------------------|-------------|---|------------------|---|
| Order 7518-6 (Six inches) | \$ 4.95 ea. | Order Now  | 10 for \$ 44.50 | Order Now  |
| Order 7518-8 (Eight inches) | \$ 8.95 ea. | Order Now  | 10 for \$ 82.50 | Order Now  |
| Order 7518-10 (Ten inches) | \$ 10.95ea. | Order Now  | 10 for \$ 99.50 | Order Now  |
| Order 7518-12 (Twelve inches) | \$12.95ea. | Order Now  | 10 for \$ 114.50 | Order Now  |

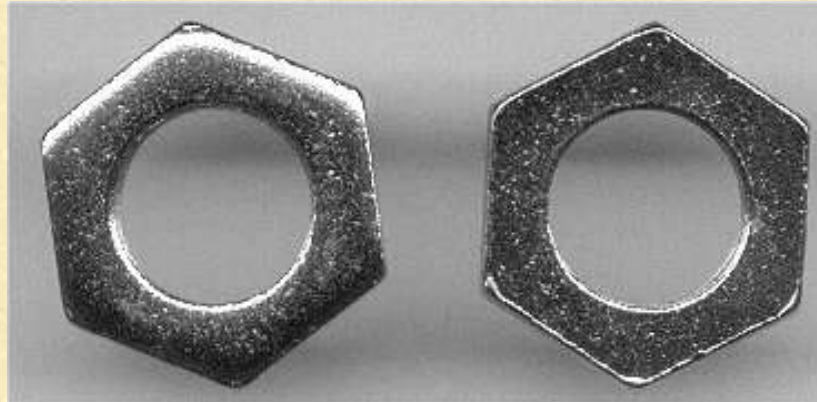



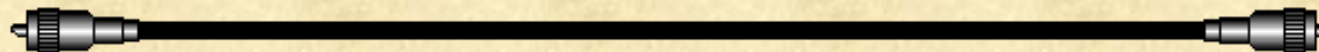

Heavy Duty (1") Nuts for the above bulkhead connectors.

| | | | | |
|--------------------|-----------------|---|----------------|---|
| 2/.99 cents | HDM1-NUT | Order Now  | 10 for \$ 3.99 | Order Now  |
|--------------------|-----------------|---|----------------|---|



50 Ohm impedance, 3 ft, 6 ft, 9 ft, 12 ft, & 18 feet.

These jumpers are made from high quality, low-loss, coax cable with PL-259 connectors installed at each end.

| | | | | |
|---------------------------|-----------|-----------|--------|---|
| <u>Three ft. (3')</u> | ORDER No. | 8X3-PLPL | \$3.95 | Order Now  |
| <u>Six ft. (6')</u> | ORDER No. | 8X6-PLPL | \$4.95 | Order Now  |
| <u>Nine ft. (9')</u> | ORDER No. | 8X9-PLPL | \$5.95 | Order Now  |
| <u>Twelve ft. (12')</u> | ORDER No. | 8X12-PLPL | \$7.95 | Order Now  |
| <u>Eighteen ft. (18')</u> | ORDER No. | 8X18-PLPL | \$8.95 | Order Now  |

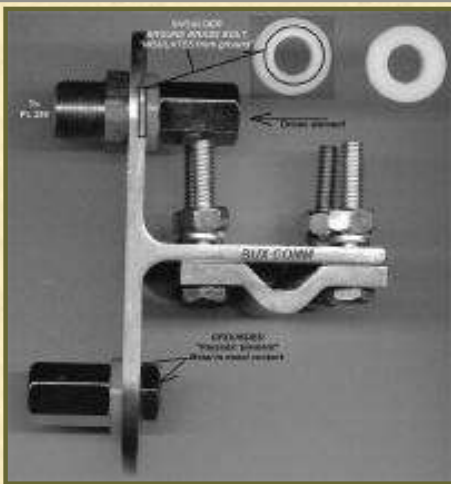

Reinforced, Double Bracket used with our "DBLSPCL" antennas shown elsewhere on this page.

Mount two mobile whips in a horizontal plane to form a compact apartment dweller Dipole, or RV antenna. Comes with two sets of mounting hardware (bolts), those shown here and another set of longer bolts for larger masts. Double Antenna Bracket as shown at left.

\$16.95 DBLBRKT



After a few years, the hardened, nylon shoulder washers become weather-brittle and break. Keep a few spares in the Ham Shack:

4 for 99¢ SM1SW



Mobile *tuneable-tip* antennas.

BHF75M 75 METER 3/8" X 24 THREAD 8 feet long \$16.95



Here's the perfect solution for your RV and portable HF antenna applications.

Use our dipole, mast-mounted bracket for 'fixed-station', field-day operating, apartment dwellers, and the RV travelers. With two of the mobile HF antennas shown at left, you can have the best of both worlds.

BHF40M 40 METER 3/8" X 24 THREAD 8 feet long \$16.95

Add to Your
SHOPPING CART 

BHF20M 20 METER 3/8" X 24 THREAD 8 feet long \$16.95

Add to Your
SHOPPING CART 

BHF17M 17 METER 3/8" X 24 THREAD 8 feet long \$16.95

Add to Your
SHOPPING CART 

BHF15M 15 METER 3/8" X 24 THREAD 8 feet long \$16.95

Add to Your
SHOPPING CART 

BHF10M 10 METER 3/8" X 24 THREAD 8 feet long \$16.95

Add to Your
SHOPPING CART 

BHF6M 6 METER 3/8" X 24 THREAD 5 feet long \$16.95

Add to Your
SHOPPING CART 

Spare 48" Tips for above *tuneable-tip* antennas. TIP48, \$2.95

Add to Your
SHOPPING CART 



By combining a pair (two) of the single band HF Mobile (loaded) tuneable-tip antennas, and (VHF) whips at left, you can have an ideal, single element, horizontal dipole (beam). This type antenna opens the world of HF and VHF communications for the apartment dweller, RV HAM, field-day operating, and a variety of other uses and applications. Shown mounted on 1 & 1/4" mast. Antenna(s) Not Included.

\$16.95 each

Add to Your
SHOPPING CART 

DBLBRKT

tuneable-tip antennas allow adjusting for minimum VSWR.

[CLICK HERE to read more about our HF DIPOLE SPECIAL!](#)

By combining a pair (two) of the single band HF Mobile (loaded) tuneable-tip antennas above, you can have an ideal, single element, horizontal dipole (beam). This type antenna opens the world of HF communications for the *apartment dweller, RV HAM, field-day operating*, and a variety of other uses and applications. The packages described below include two antenna, the Double Antenna-Bracket (DBLBRKT), and mounting hardware

\$ 39.97 DBLSPCL (without BALUN) *With BALUN, see "DBLCOMBO", below.*

75 Meters →  , 40 Meters →  , 20 Meters →  ,



17 Meters →  , 15 Meters →  , 10 Meters →  ,



6 Meters → 

By combining a pair (two) of the single band HF Mobile (loaded) tuneable-tip antennas above, you can have an ideal, single element, horizontal dipole (beam). This type antenna opens the world of HF communications for the *apartment dweller, RV HAM, field-day operating*, and a variety of other uses and applications. The package described below includes two antenna, the Double-Bracket (DBLBRKT), mounting hardware, and **BUX**

BALUN (UNUN). SAVE \$\$\$\$\$, ADD the BUX UNUN , shown below, BOTH, DPLSPCL & BUXUNUN, for only \$ 54.97,

ORDER, DBLCOMBO

75 Meters →  , 40 Meters →  , 20 Meters →  ,

17 Meters →  , 15 Meters →  , 10 Meters →  ,

6 Meters → 

FAX 434 525 7818 or Mail order form, Click Here!

We accept:   

FAX 434 525 7818 or Mail order form, Click Here!

Web Page Design and HTML By
G. E. 'Buck' Rogers Sr K4ABT d/b/a BUX CommCo™® ©
Copyright © 1996-2004
All Rights Reserved

BUX CommCo™®
115 LUENBURG DRIVE
EVINGTON, VIRGINIA 24550

FAX 434 525 7818

"0043694"

[K3MT](#)

and daughter KF4LGR

present . . .

A six-band, HF Windom antenna

April, 1997

Corrected September, 2000

This Windom antenna was marketed in the late 70's and early 80's as *Smithe's Windom*.

It was designed to cover 80, 40, 20 15, and 10 meters. By serendipity, it also covers the 17 and 2 meter bands.

(Authors' note - we now market a revised version of this antenna that covers all HF bands except 30 meters, and covers 30 meters with use of an antenna tuner. e-mail us for details.)

Now, how was a Windom antenna developed? It began with a center-fed, half-wave dipole.

This antenna also works fairly well on all *odd* harmonics, because the center of the antenna has a current maximum, just as a half-wave antenna has. But on *even* harmonics, the center of the antenna has a current *minimum*. It is a high-impedance, center-fed Zepp antenna on even harmonics. This figure shows the current standing wave on a 3.5 MHz half-wave dipole, and the currents on the second and third harmonics (7 and 10.5 MHz.)

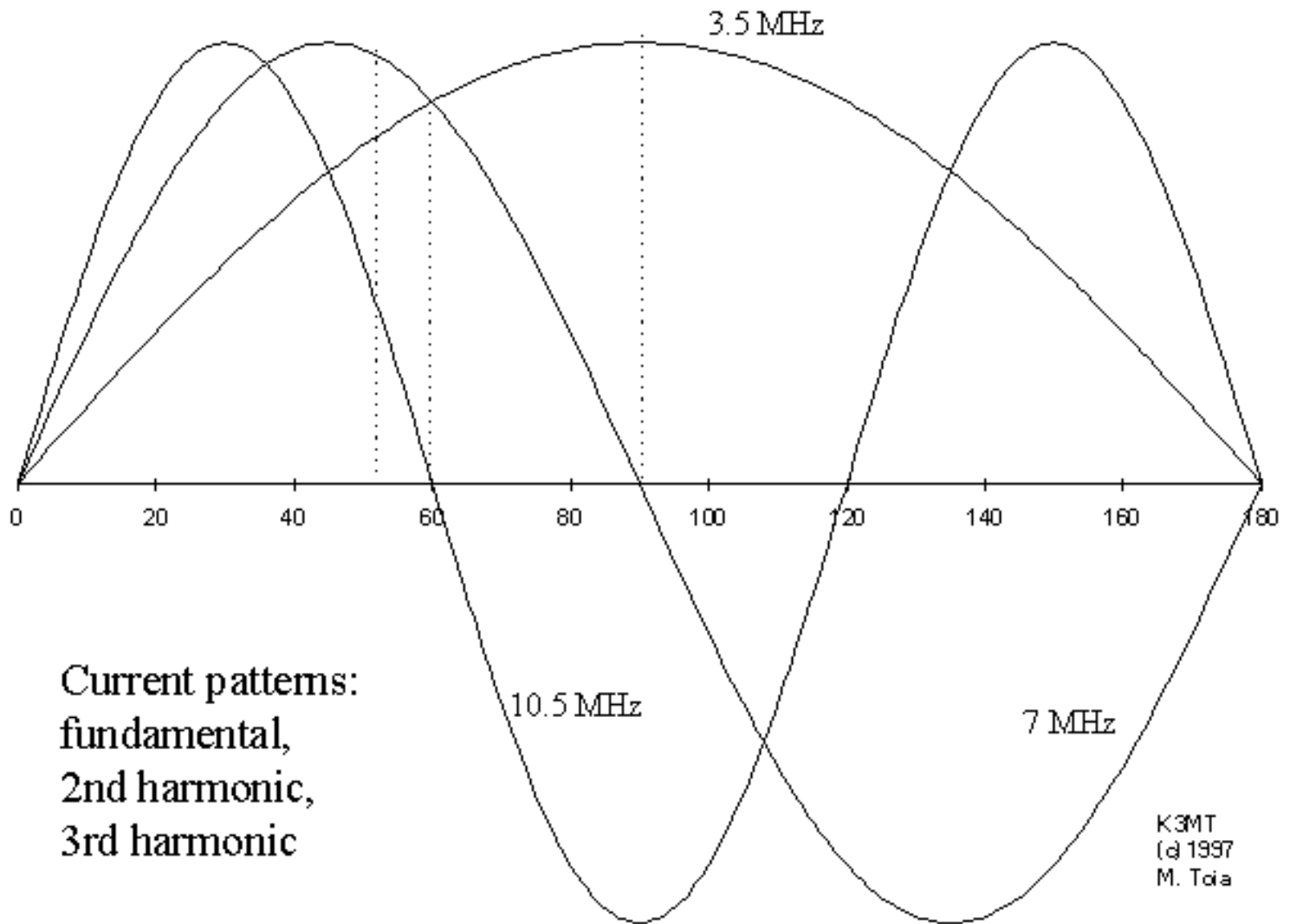

When fed at the center - 90 degrees from one side - a good match to coax occurs on 3.5 MHz.

But the match at 7 MHz is bad: the current is a minimum, so the impedance is very high.

So try feeding it 60 degrees from the left end. Since the current at 3.5 MHz is lower than at the center (and the voltage is higher) the feed impedance is higher - over 100 ohms. But the antenna is still resonant, so the *reactance* is low! What you have done is to increase its feed resistance.

Look now at the action on 7 MHz. The feed point is no longer at a current

minimum. Therefore, the second harmonic feed impedance is quite a bit lower than it had been earlier, and is in the range of a few hundred ohms. Since the antenna is resonant here, too, it has low reactance.

But now the feed impedance at 10.5 MHz is poor, because the 3rd harmonic current standing wave is now a minimum. So try feeding it at about 52 degrees from the left end. Here the match at 3.5, 7, and 10.5 MHz is fairly good. The impedance at all three is now somewhere around 200 to 400 ohms.

Now you can play these games all day, and if you build this antenna,

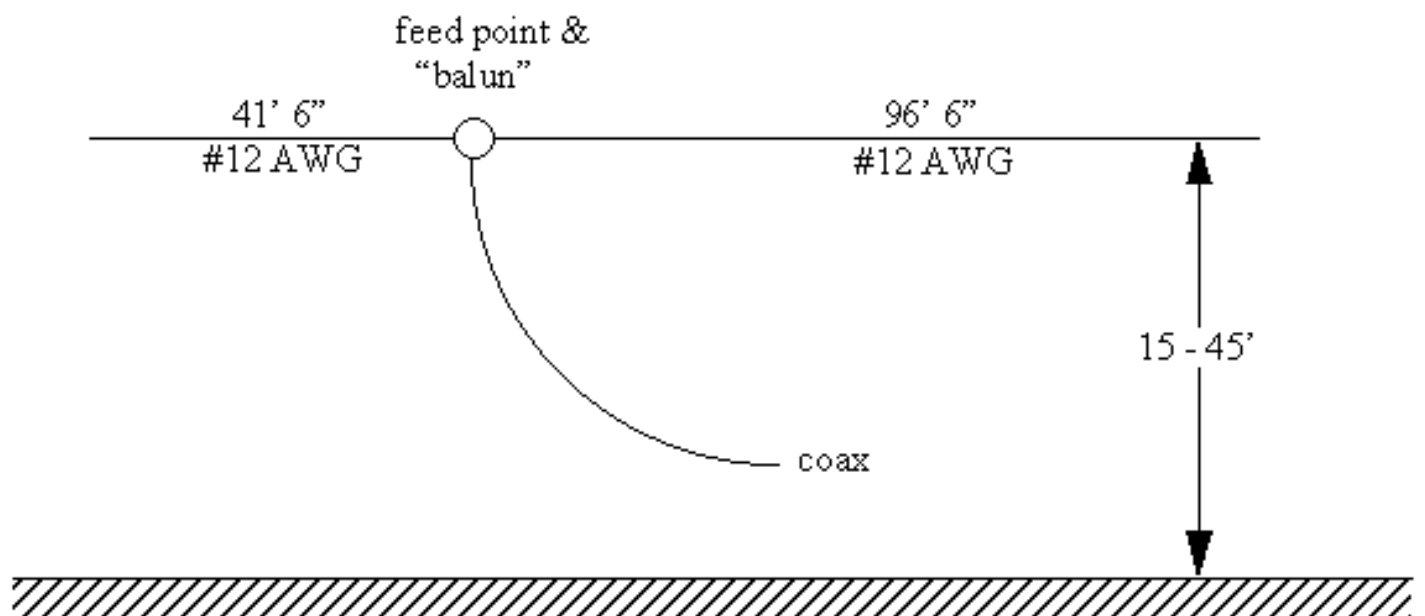

Off-center fed Windom
mounted horizontally

K3MT
(c) 1997
M. Toia

you will find it works well on 80, 40, 20, 17, 15, 12, and 10 meters - plus 2 meters as well,
provided you pay attention to the balun! To boot, the balun matches 50 ohm coax without an antenna tuner. I admit, that this is a compromise design, and a tuner helps on the low end of 80 meters a bit, and on the high end of ten. But without a tuner, and with a fussy rig - my Drake TR-7 - a lot of DX has been worked on all bands, from 80 through 10 meters.

I put my windom up a bit differently, as shown here:

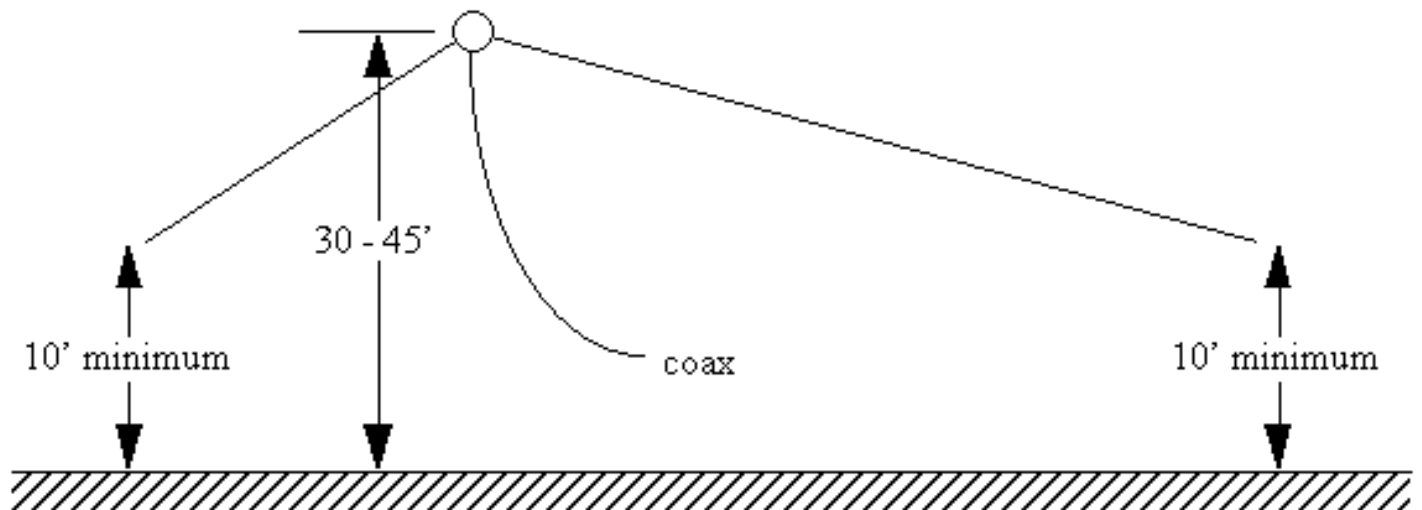

Mounting the Windom
as an inverted vee

K3MT
(c) 1997
M. T. Oia

Balun Details

What about the balun? The original unit sold with the Smithe Windoms is a Guanella-type (as opposed to a Ruthroff-Sevick design) parallel transmission line balun. Since the design impedance was measured to be between 300 and 600 ohms, a 9:1 down-converting balun with three 150 ohm lines was designed and built.

To build one, obtain an Amidon T-200-2 core, tape it with two layers of black poly electrical tape, and obtain some #18 AWG magnet wire with a bit of #17 AWG teflon spaghetti. Twist the magnet wire to make three twisted pairs - about one twist per inch. Wind 11 turns of one pair on the core, and slip the teflon spaghetti over *each* lead of the remainder (untwist it a bit to do this.) Then wind 8 more turns back overtop the 11 turn winding. Do this with the other two twisted pair lines as well. Space them on the core so no two lines overlap.

(Apologies and thanks to readers who noted that the original web article called the core a "T-250-2." The correct core is a T-200-2.)

This image shows a single winding on the core - make two more windings like it.

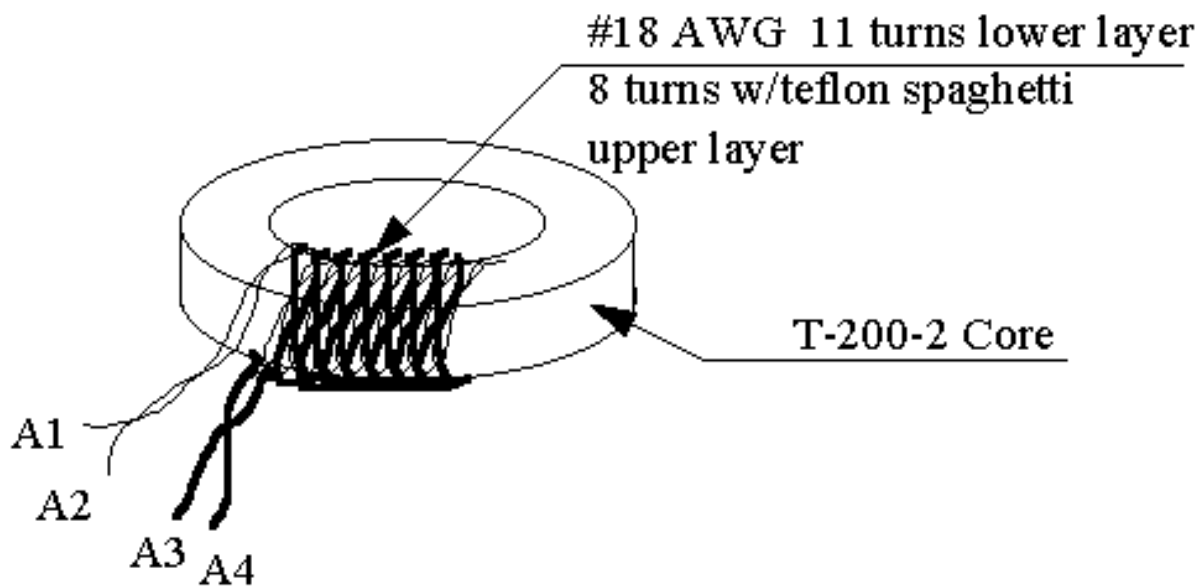

Balun:
One of three windings

K3MT
© 1997
M. Toia

Get an ohmmeter to check continuity. Label the lines A, B, and C, and their ends 1 & 2 where the uninsulated wire starts onto the core, and 3 & 4 where the wire (insulated with the spaghetti) leaves the winding. Pay attention to the wiring detail that follows, and use your ohmmeter to check your work. Label the wires so there is continuity from:

- A1 to A3
- A2 to A4
- B1 to B3
- B2 to B4
- C1 to C3
- C2 to C4

Refer to the next image to guide the balun connections, and wire the balun as follows:

- Connect A1, B1, and C1 together. These will connect to the center conductor of the coax.
- Connect A2, B2, and C2 together. These must connect to the coax braid.
- Connect A3 to the *short* end of the windom. *This is important!*
- Connect A4 to B3, and B4 to C3.
- Connect C4 to a 110 pF, 6 kV capacitor.
- Connect the other end of this capacitor to the *long* end of the windom.

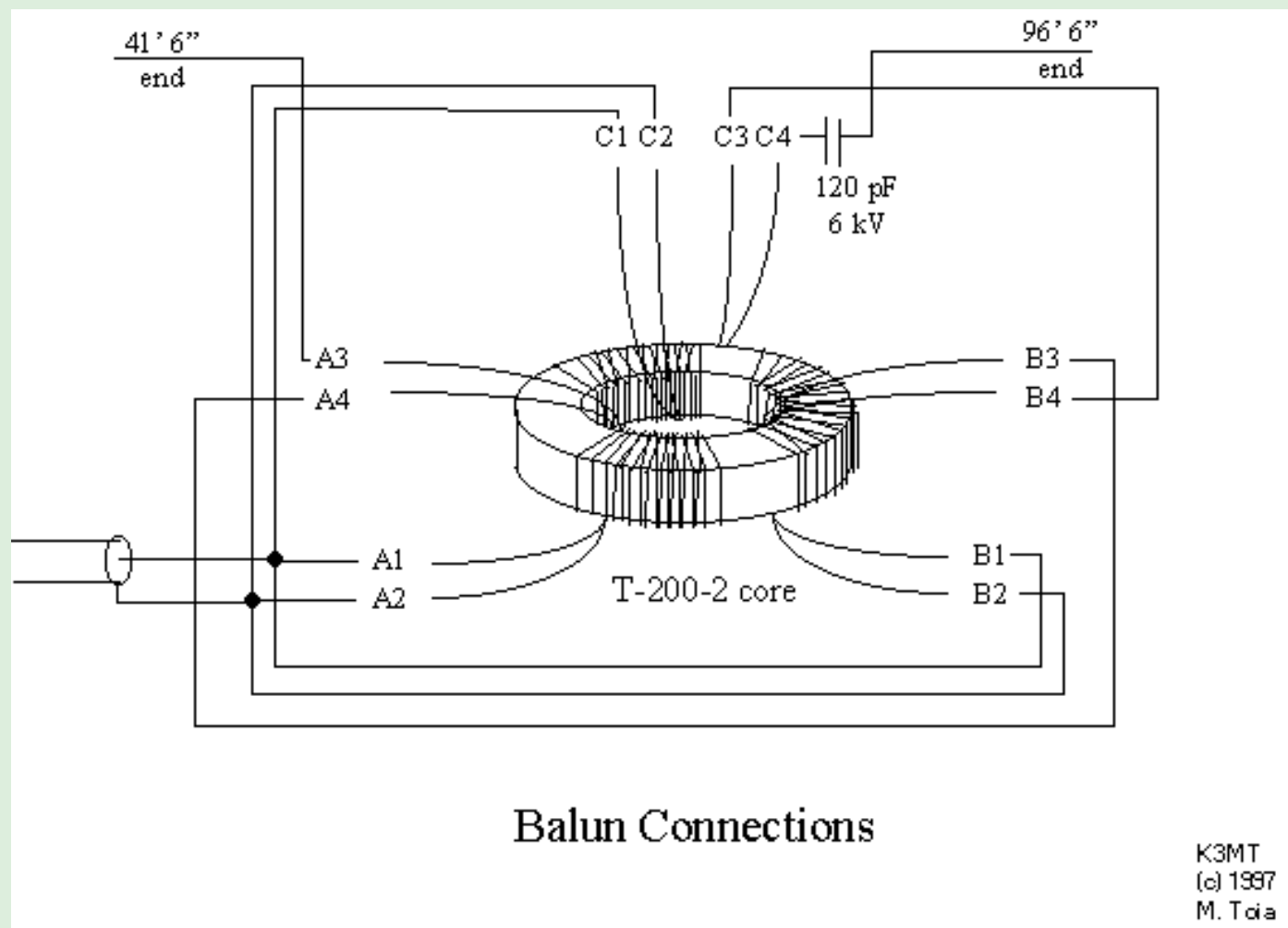

NOTE: if you think the balun is too complicated to build, e-mail us. We can

provide one.

Ask for pricing. In fact, we will be glad to provide an entire windom, according to this design, if you wish.

You are now ready to install and enjoy your windom. If you have the same luck that K3MT and daughter KF4LGR have, it will have been worth all the trouble!

For more unusual antennas, visit our [web page](#).

This antenna is featured in K3MT's [Book](#) about HF antennas

**73
K3MT
KF4LGR**

X-Beams

KQ6RH

(C) 1998, 1999, 2000

Ray Jurgens

(Up-Dated 2/25/2000)

X-Beams

The X-Beam has been described in QST and the ARRL Antenna Compendium # 1 in enough detail that it should not be difficult to assemble this antenna and obtain the specifications indicated here, though the specifications claimed by the author may be a little over-stated (see reference 1). The claim is that the antenna has 6.0 dBd and 18 dB F/B ratio. The figures below indicate the reality of the situation based on the E&M modeling program. I present both the free space patterns and the ground mounted pattern for 20' height.

X Beam Free Space

Free Space
Azimuth

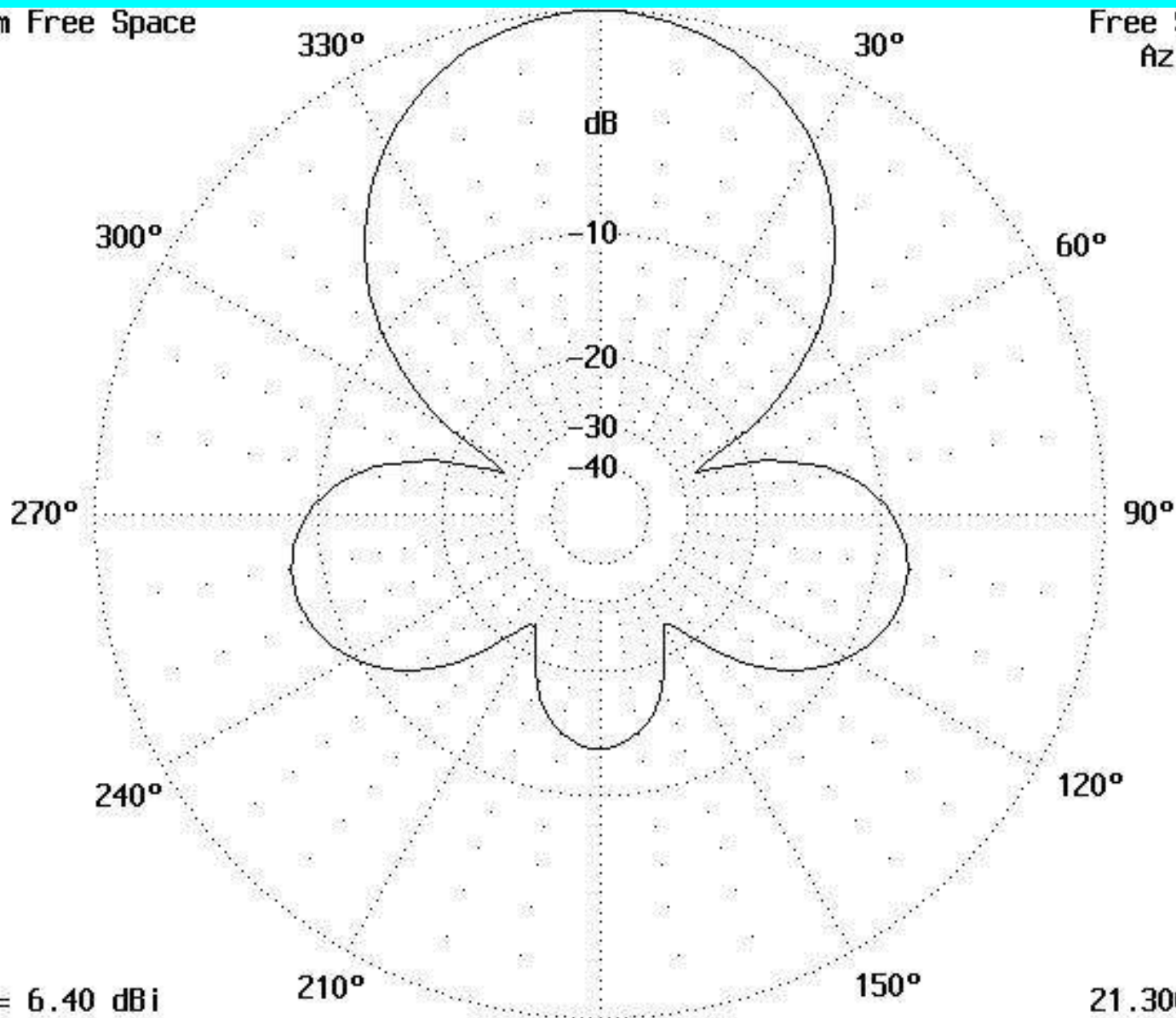

Figure 1

Azimuth Pattern for X-Beam in Free Space

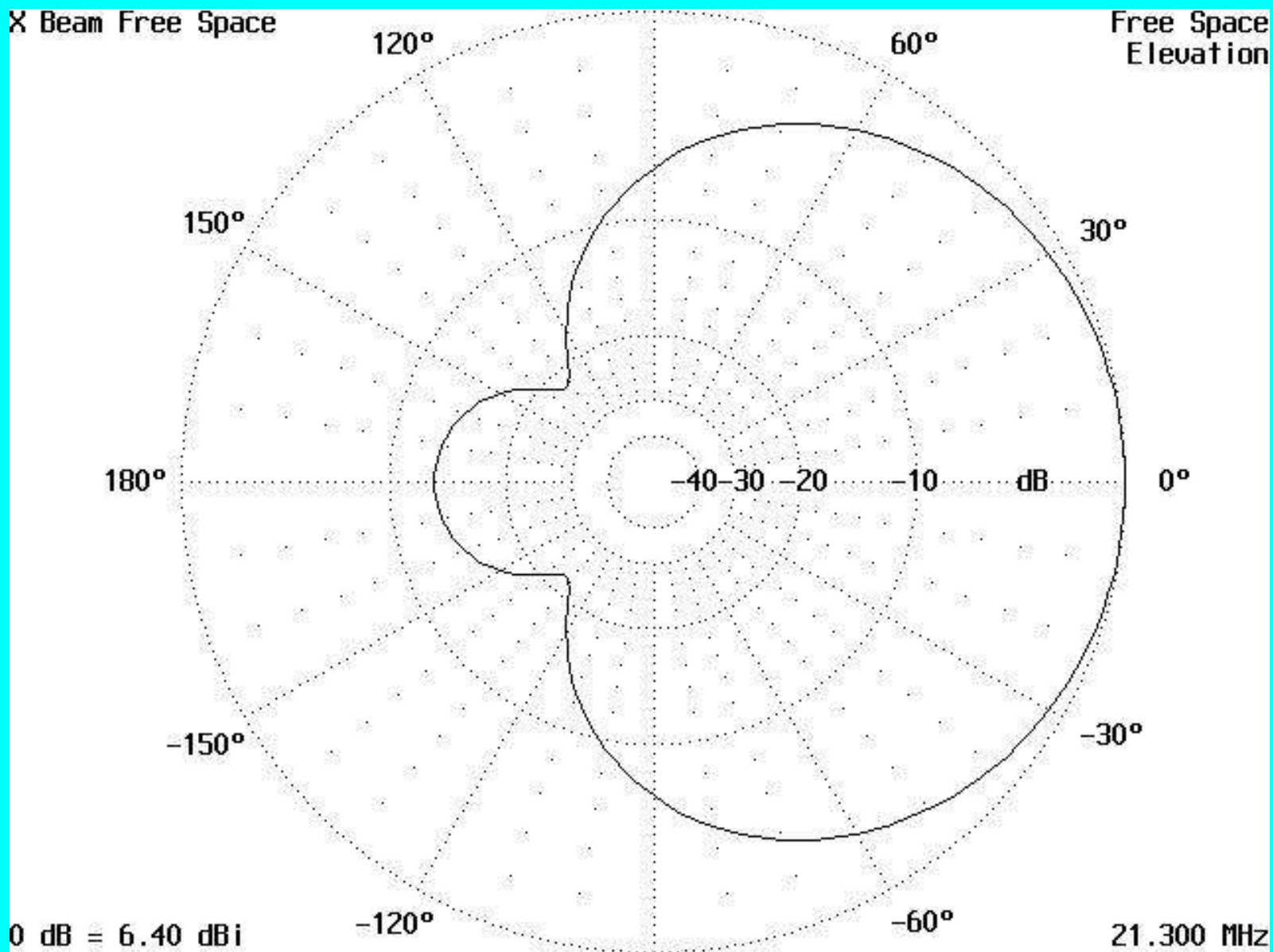
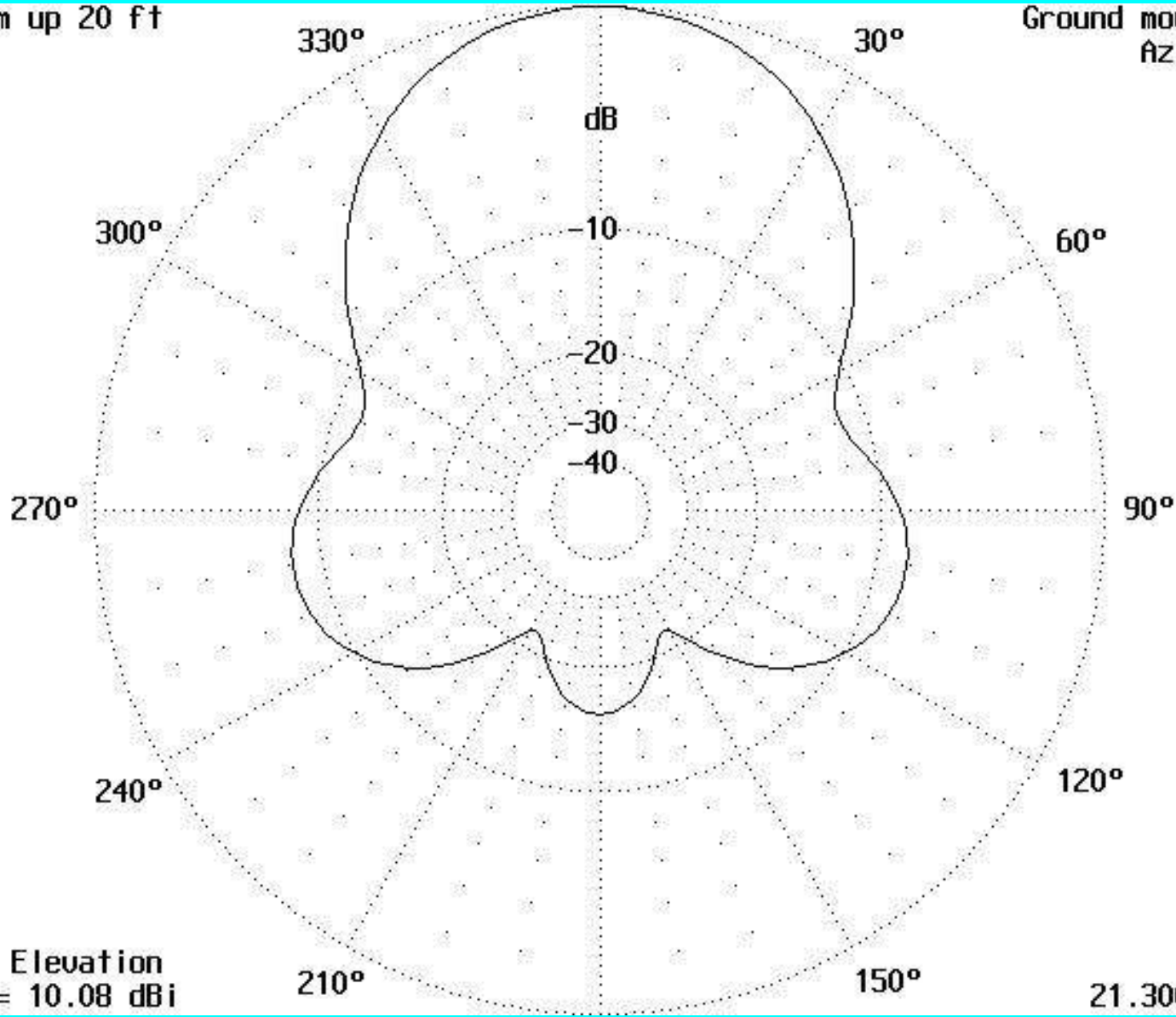

Figure 2
Elevation Pattern for X-Beam in Free Space

Note that the total gain is 6.4 dBi, not 6.0 dBd, and although the F/B ratio is about 13 dB, the side lobes are much worse (about 8 dB). The performance of the antenna looks a bit better when placed about 20 feet above the ground as indicated by the following two figures.

X Beam up 20 ft

Ground mounted
Azimuth



30.0° Elevation
0 dB = 10.08 dBi

21.300 MHz

Figure 3
Azimuth Pattern of X-Beam Elevated 20 Feet Above Ground

X Beam up 20 ft

Ground mounted

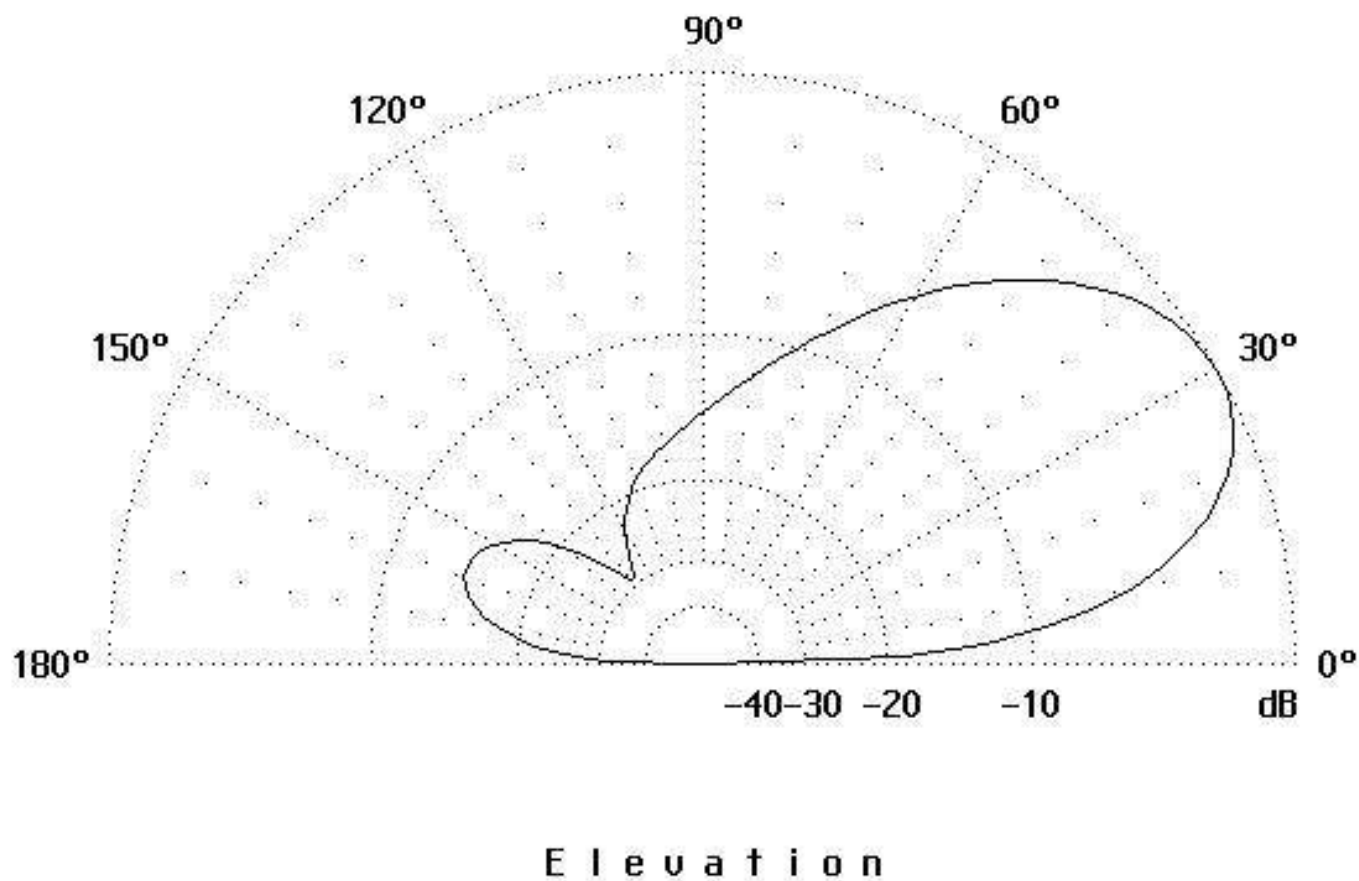

0 dB = 10.08 dBi

21.300 MHz

Figure 4**Elevation Pattern of X-Beam Elevated 20 Feet**

Note that the gain peaks at a 30 degree launch angle with a peak gain of about 10 dBi or 8 dBd. So this is a fairly good antenna, but not quite as good as the Author indicates. The poor side-lobe level is perhaps the greatest deficiency of the X-Beam, however, it is relatively easy to construct, and portable versions based on telescoping sections of aluminum tubing are easy to transport and erect.

In this case, I'll only consider the design of a 15 meter version, because the 20 meter version requires aluminum spreaders 13' 9" long, and this length is larger than I can construct in my back yard, and the tubing size required is considerably larger than what can be considered as light weight and portable. The spreader (arm) length for 15 meters is only 9' 3" . The director tails are 4' 2", and driven-element tails are 4' 10". The sum of the tails is 9', and

the distance between the tips is $\sqrt{2} * 9' 3" = 13' 1"$, which leaves 4' 1" to be spanned by nylon line or cord. You will also need 13' 1" lengths of Nylon cord to span the tips in the front and rear to prevent them from pulling apart when the tails are added. The spreaders (arms) can be assembled from three standard sizes of aluminum tubing beginning with 1/2" OD #22 which has an ID of 0.444 inches. This 1/2" will accommodate 7/16" OD #18 tubing which has an ID of 0.339 inches. The 7/16" tubing will then accommodate 5/16" #20 tubing. I used 4' of 1/2", 4' of 7/16" and 2' of 5/16" tubing for each spreader arm with the first two overlapped by 6" and the outer one overlapped by 4". The hub adds an extra inch from the center of the mast giving a total distance to the tip of exactly 9' 3". The author never states wire size for the tails in the ST article, but in the Antenna Compendium article, he indicates #19 vinyl-covered wire was used. We used #20 vinyl-covered lamp cord by splitting it apart. Various light weight speaker cables work equally well. The directions for tuning this antenna are given in the pair of articles and should be followed in order to get best results. My experience with this antenna mounted about 18' above the ground is that the driving impedance is roughly 25 Ohms when properly tuned. The author indicates a good match with 50 Ohm coax, which probably means that some compromise in performance was accepted to get the good match. The driving impedance does vary with height above the ground.

Parts Required

Discussed above.

References

1. Anderson, Brice, W9PNE, "Designing X-Beams," ARRL Antenna Compendium, Vol. 1, pps. 64-66, 1985.
2. Anderson, Brice, W9PNE, "Horizontal X beams for 15 and 20 Meters," ST, pps. 33-35, March, 1993.
3. Note, all modeling of this antenna has been carried out using Brian Beesley's AO program.

[Return to Main Menu](#)



Enjoy world-class music by an active ham!

[click here](#)

Welcome Anonymous

[Become a member!](#) or [Login!](#)

Contesting Online -- Ham Radio Contesting on the Net

The NW3Z antenna information has moved to <http://nw3z.contesting.com>.



Community

- [Home](#)
- [eHam.net Home](#)
- [Articles & Stories](#)
- [Speakout](#)
- [Strays](#)
- [Survey](#)
- [My Profile](#)

Resources

- [This Week's Contests](#)
- [Classified Ads](#)
- [Contest Links](#)
- [Product Reviews](#)

Contester Lookup

eHam Callbook

Contest Links

Contest Lists

[3830](#)

[CQ-Contest](#)
[CT-User](#)
[NA-User](#)
[SD-User](#)
[TRLog](#)
[VHF Contesting](#)
[WriteLog](#)

Other Lists

[Amps](#)
[AntennaWare](#)
[Propagation](#)
[RFI](#)
[RTTY](#)
[TenTec](#)
[Top Band](#)
[Tower Talk](#)
[Yaesu](#)

[Mailing List FAQs](#)

Site Information

[About This Site](#)
[Contesting.com Team](#)

Copyright 2000-2004 eHam.Net

contesting.com is a community web site for amateur radio (ham radio) operators interested in radio sport and contesting.
Contact webmaster@contesting.com with comments or questions.

[Site Privacy Statement](#)



This web site is hosted & created by AkornHosting.com

The Optimized Wide Band Antenna

[Contesting Online Home Page](#)

[15M on 48' Boom](#)
[15M on 36' Boom](#)
[20M on 48' Boom](#)
[10M on 48' Boom](#)
[10M on 24' Boom](#)
[20M/15M Interlaced](#)
[Construction Notes](#)
[Conclusion](#)

The Optimized Wideband Antenna

Yagis for 20m - 10m
by Nathan A. Miller
NW3Z
Penn State University

Hello again to every one that read the article I had posted here previously. I have updated all of the previous designs and have added some new ones that you may find interesting. In addition to the 48' boom yagi antennas, I have included a 36' boom 15m antenna as well as a 24' boom 10m antenna that work almost as good as their big brothers. Finally I have posted some pictures of these antennas; both at the K3CR and WP3R contest stations.

Notes regarding stacked installations of antennas:

There were originally two separate versions of the 48' boom 20m antenna: one was designed in free-space and worked well as a stand-alone antenna while the other was designed to operate stacked on a 175' tower. The reason for re-optimization in the stack was that the F/B of the original design was degraded when it was placed into the 6/6/6 stack. To improve the stacked F/B, I unfortunately had to sacrifice the excellent VSWR characteristics of the original antenna. In addition, the F/B of the individual stack-optimized antenna is not as good when it is used independently. The only reason the F/B was degraded is that there is a back-lobe generated at the same elevation angle as the main beam: for the 175' tower this is at 7 degrees. Other than this single lobe, the rear suppression of the stack is quite good. In short, I have been thinking that the small increase in stack performance is not worth the compromises in individual antenna performance.

For this reason, I show only the optimum stand-alone design in this article. I should note that any time antennas are stacked, there is the potential for serious effects on both the F/B and VSWR of the antennas. In general practice, yagis are never stacked closer than .7l. At the K3CR station, the 20m antennas are seperated by .85l which would allow the stand-alone designs to perform relatively well. The 15m antennas are seperated by 1.3l : there will eventually be 3 of the 15m antennas on the 185' tower. While a fourth antenna could have been added without problem, modeling showed that the increase in performance would have been undetectable. For the 10m installation, there will be 4 antennas on the 175' tower with a spacing of by 1.25l. Again, additional antennas could have been added but the performance increase was negligible.

This brings up another question. In the [earlier article](#) I posted to WWW.CONTESTING.COM, I mentioned the F/B problems encountered when stacking 6 four element antennas on a large tower. This method will produce a large forward gain but the side-lobe and back suppression will always be limited by the short boom antennas. While there are many advantages to installations such as this, such as the ready availability and low cost of short boom antennas, I still think a smaller number of high performance antennas will produce superior results with less mechanical complexity.

But no matter how good your antennas are, the key to a successful station lies in one simple thing.... RELIABILITY! In stacked installations, the importance of reliable switching and impedance matching systems cannot be over stressed.

[MS Word Version - 2.0MB](#)

This page was last updated on 05/20/98.

You are visitor [Hit Counter](#) since 5/19/98



Modeling 6 Long-Boom Yagis



L. B. Cebik, W4RNL

Over the last year or so, I accumulated designs for 5 different 20- meter Yagis with boom between 45 and 55 feet long and having either 5 or 6 elements. After the appearance of a preliminary version of these notes, a 6th was donated. All display an average free space gain from 14.0 to 14.35 MHz of over 10 dBi, with good front-to-back ratios averaging well over 20 dB across the band. It seemed to be an interesting project to model all 6 on the same versions of NEC (in this case, NEC-2 with Leeson corrections and NEC-4, using EZNEC Pro) and do some comparative assessment.

What actually emerged is a lesson in some of the difficulties in making such assessments. Some of those difficulties arise from limitations of the programs (and every version of NEC/MININEC has limitations). Others emerge from differences among models and specification sheets that cannot be resolved without additional data not at hand. Hasty modeling and simplistic conclusions can yield fog where clarity is desired.

The Six Beams

The six beams are the following:

- 1. A 5-element, 45' boom design by W6NGZ, published in *CQ* for October, 1996, p. 22.
- 2. A 5-element, 48' boom design by K6STI, published among the beams in *YA*, which accompanies the *ARRL Antenna Book*--this is a medium strength model.
- 3. A 5-element, 48' boom design by W3LPL, published on the World Wide Web.
- 4. A 5-element, 55' boom design by K4SB, originally developed in monotaper for 10 meters, modified for this study by me for a somewhat arbitrary element taper (used by permission).
- 5. A 6-element, 48' boom design by NW3Z, published on the World Wide Web.
- 4. A 5-element, 48' sent to me by WB0DGF and once published on the Hy-Gain web site as HG205XLB.

The beams are interesting for their differing design features, not the least of which is the choice in element spacing, as shown in the figure below.

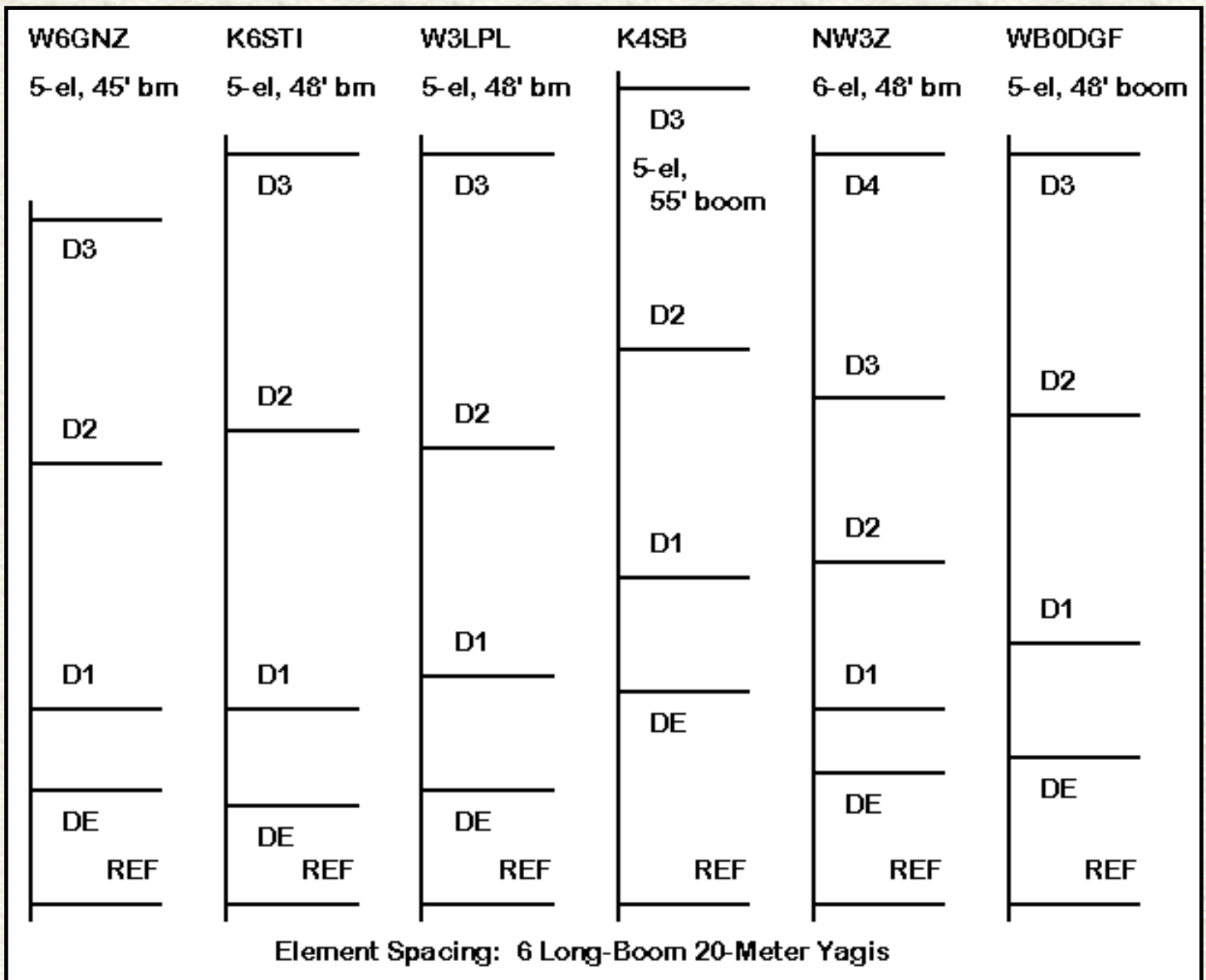

The K6STI has the lowest design feedpoint impedance, which is indicated in the reflector-driver spacing. The W6GNZ design aims for a higher feedpoint impedance and uses a correspondingly wider reflector-driver spacing. The W3LPL design has a comparable feedpoint impedance and hence a similar reflector-driver spacing to the W6GNZ design, despite the differences in boom length. These three designs are similar beyond the driver in that the directors are proportionally spaced, relative to each other. However, do not ignore the ability of D2 to affect feedpoint impedance. The WB0DGF design demonstrates how a different taper schedule may influence the required spacing for a design, since its reflector-drive spacing is greater than the K6STI antenna, but the DGF version has only a moderately higher feedpoint impedance.

The longest model (K4SB) tries for a direct 50-Ohm feed and uses the widest reflector-driver spacing. D1 is not especially different in spacing from the driver relative to the first three models. The truly different design is the NW3Z 6-element Yagi, which uses a moderately wide spacing between the reflector and driver combined with the closely spaced D1 to set the basic parameters of the antenna. However, D2 also plays a crucial role in setting the feedpoint impedance: at correct spacing, the feedpoint impedance is a good coax match; with D2 40" closer to D1, the feedpoint impedance drops to the 25-Ohm neighborhood without seriously affecting the gain and front-to-back characteristics of the antenna.

These notes are not designed to recommend one design over another, either overtly or tacitly. That would require a detailed construction analysis plus the resolution to some modeling questions which I intend to leave open.

Some Modeling Preliminaries

Unfortunately, modeling Yagis within the amateur community has become somewhat of a casual process, without the care and attention to detail used by serious designers, such as the author's of the designs shown here. Whatever the source of the design--YO, Yagi-Max, or simply manual design on AO or EZNEC--evaluation of a design requires good modeling practice.

NEC-2 without a correction factor cannot accurately model a linear element using a tapered-diameter schedule. For that reason, some implementations of NEC-2 include Leeson or similar corrections, which substitute a carefully calculated mono-tapered element for each tapered-diameter element in an array. However, it is possible to disturb the substitute element by paying too little attention to segment length equality. Especially at current nodes (the center of near-1/2 wavelength elements), segment length needs to be equalized along a linear element (whether it is a single dipole or a part of a larger array). Since the Leeson corrections modify the length and diameter of a wire but not its segmentation, segment lengths should be equalized in advance. This factor plays an especially important role where the designer may place a very-large diameter short segment at the element center to simulate boom-to-element mounting plates and hardware. Often--as with the K6STI and WB0DGF models--the length of this segment sets the approximate length of segments in the adjoining sections of the element.

Therefore, for the models at hand, segmentation was increased to yield segment lengths between 8" and 12", depending upon the model. The K6STI and WB0DGF models use the shorter lengths due to their center "lumps." (Note that the WB0DGF model omits the center "lump" on the driven element, while the K6STI model preserves it.) The W6NGZ model uses 12" segments, because they came out most even with the element sections in the design.

Other beams used 8" (W3LPL) or 10" (K4SB, NW3Z) per segment for similar reasons: the chosen segment length turned out to be the best way to achieve roughly equal length segments on the most elements. Despite best efforts, some variations inevitably result. Designers will always have, for any segment length chosen, a section that comes out to be $n.5$ segments long. Some will choose center sections that for any reasonable segment length seem to require an even number of segments. Adding extra segment is necessary for the driver--and hence, for the other elements in order to keep segment junctions as well aligned as possible.

NEC-4, by its initial reports, overcomes the NEC-2 weakness with tapered-diameter elements. Unfortunately, the initial reports have proven overly optimistic. Although NEC-4 is a vast improvement over uncorrected NEC-2, it falls short of the standard set by NEC-2-corrected, which also correlates with MININEC results. (MININEC does not have a tapered-diameter element problem, although it has other limitations.)

The NEC-4 limitation is somewhat minor for general purpose modeling, unless the element shows too large a diameter change between wires in the element, especially close to the current node, with the driven element the most crucial. This condition exists with the K6STI model.

In order to show the modeling differences between NEC-2-corrected and NEC-4, I have modeled all 6 beams in both programs via EZNEC Pro. (I could have applied the Leeson equations to the NEC-4 runs, but that would have produced the same results as the NEC-2 runs.) I graphed data comparatively for NEC-2-corrected and for NEC-4, to include free space gain in dBi, 180-degree front-to-back ratio, feedpoint resistance, and feedpoint reactance. SWR data is also shown wherever the source impedance is close enough to 50-Ohms to make such data relevant. All graphs run from 13.8 to 14.4 MHz in order to show downward slides of NEC-4 curves.

Let's look at the designs individually.

The W6NGZ 5-element, 45' boom model

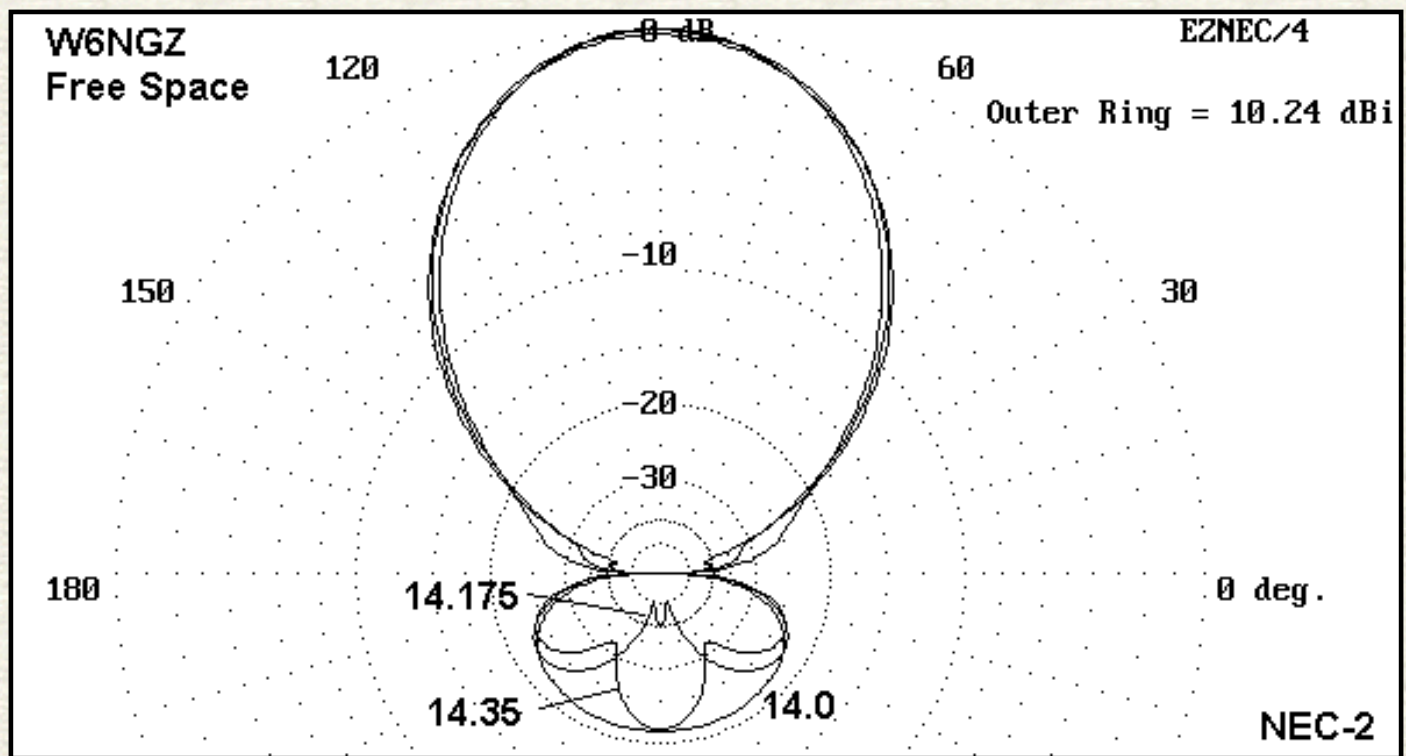

The W6NGZ model is the shortest of the five, but it sustains a free space gain of over 10 dBi across the band, with better than 20 dB front-to-back ratio everywhere on 20. The element taper is from the *CQ* article, and it contains no compensation for element mounting plates at the element center. Within these constraints, NEC-4 and NEC-2-corrected tell very similar graphical stories about the beam. Differentials are marginal at best, although a wee bit of excess gain estimation and a slide of the curves downward in frequency are both evident.

Free Space Gain W6NGZ 5-Element 45' Boom

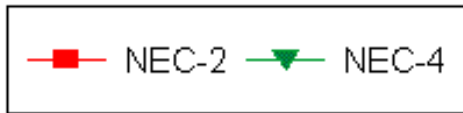
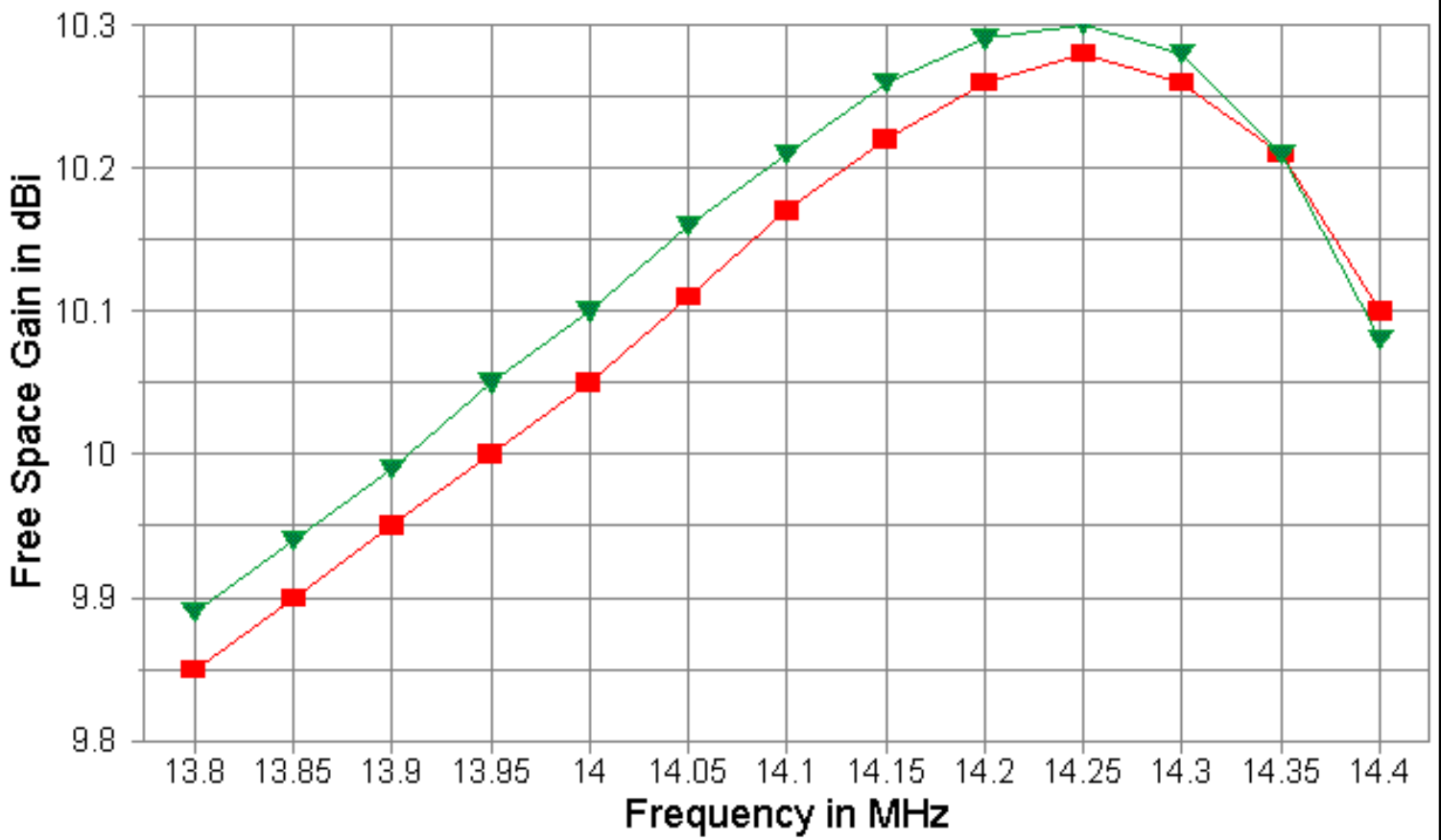

180-Degree Front-to-Back Ratio W6NGZ 5-Element 45' Boom

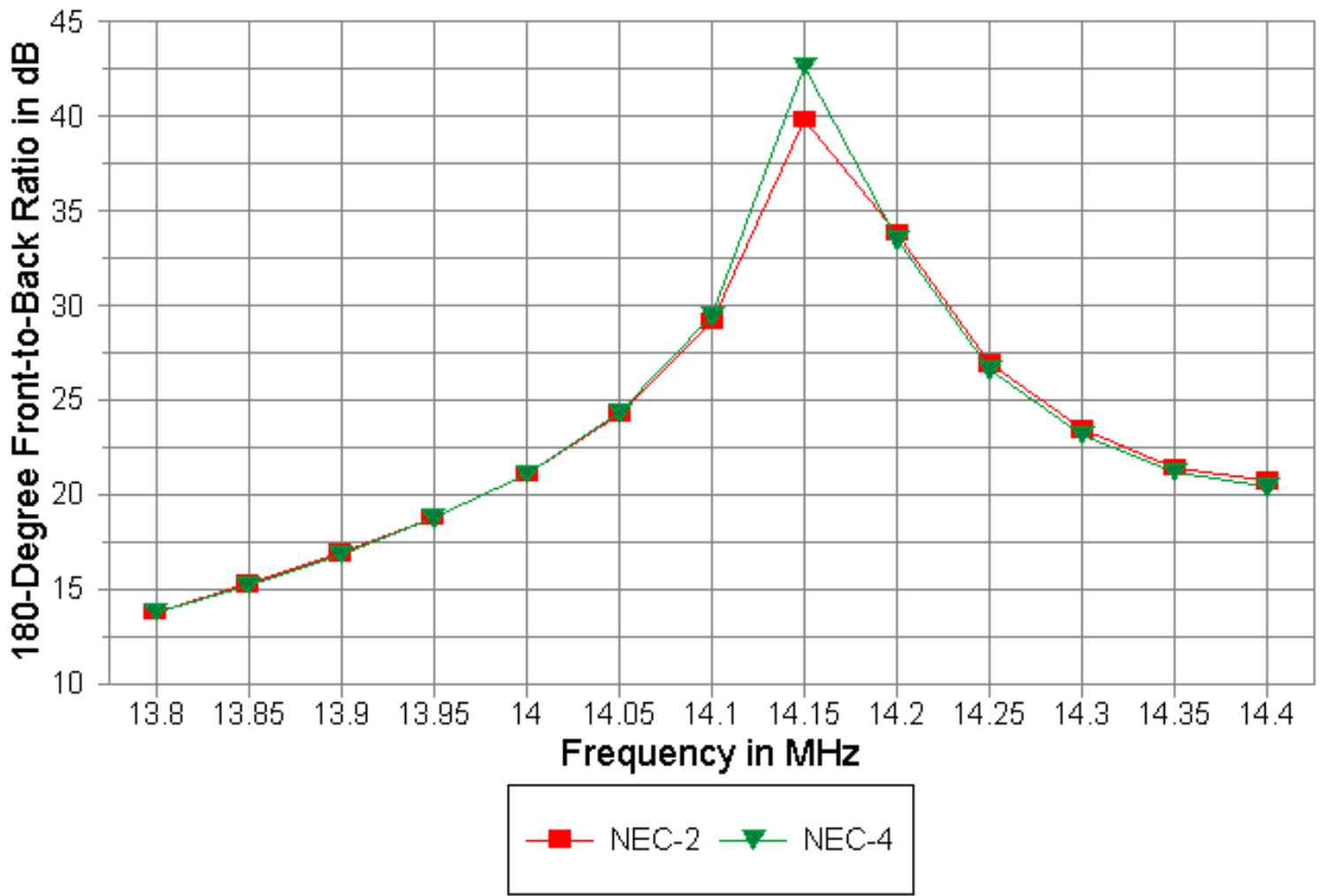

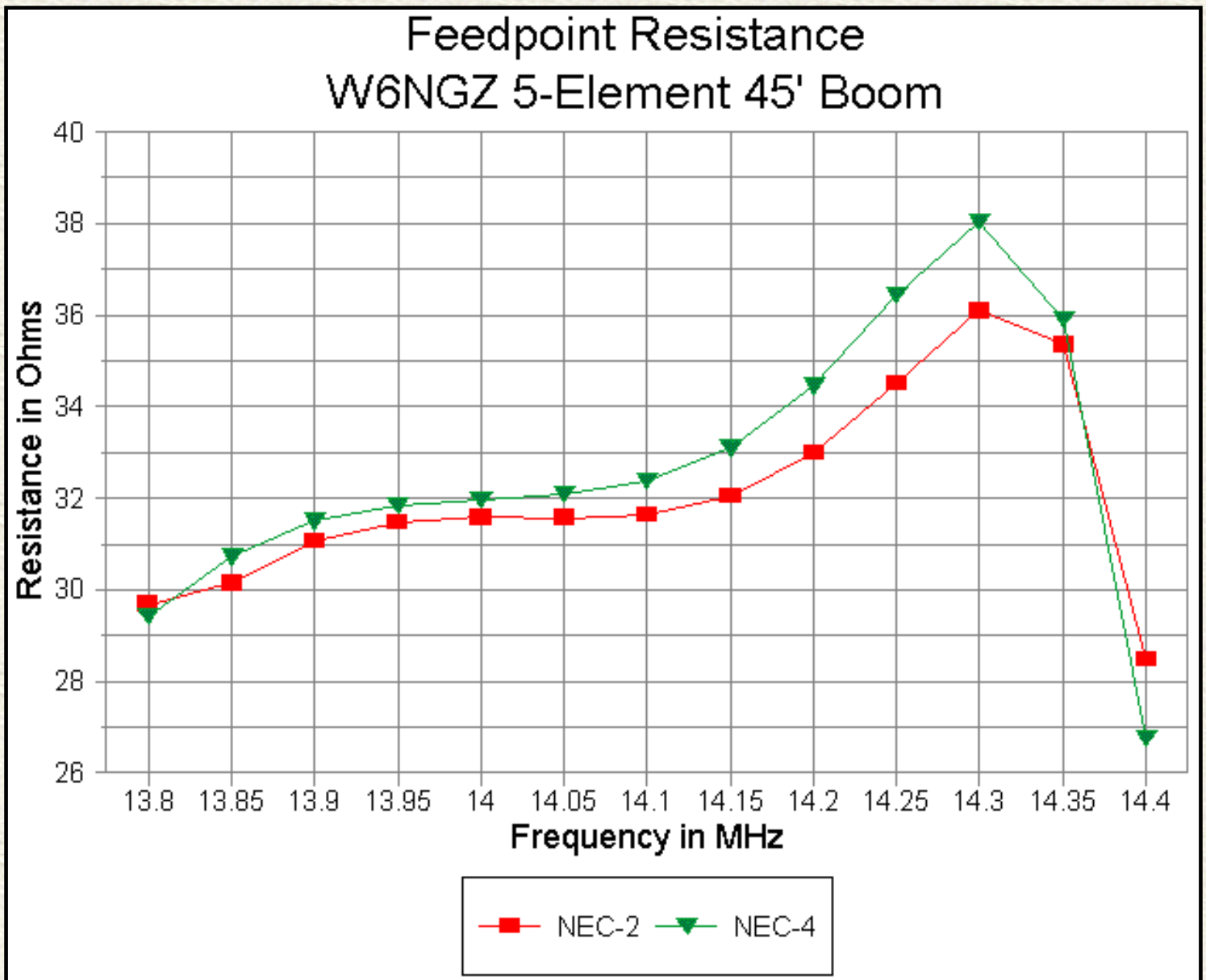

Feedpoint Reactance W6NGZ 5-Element 45' Boom

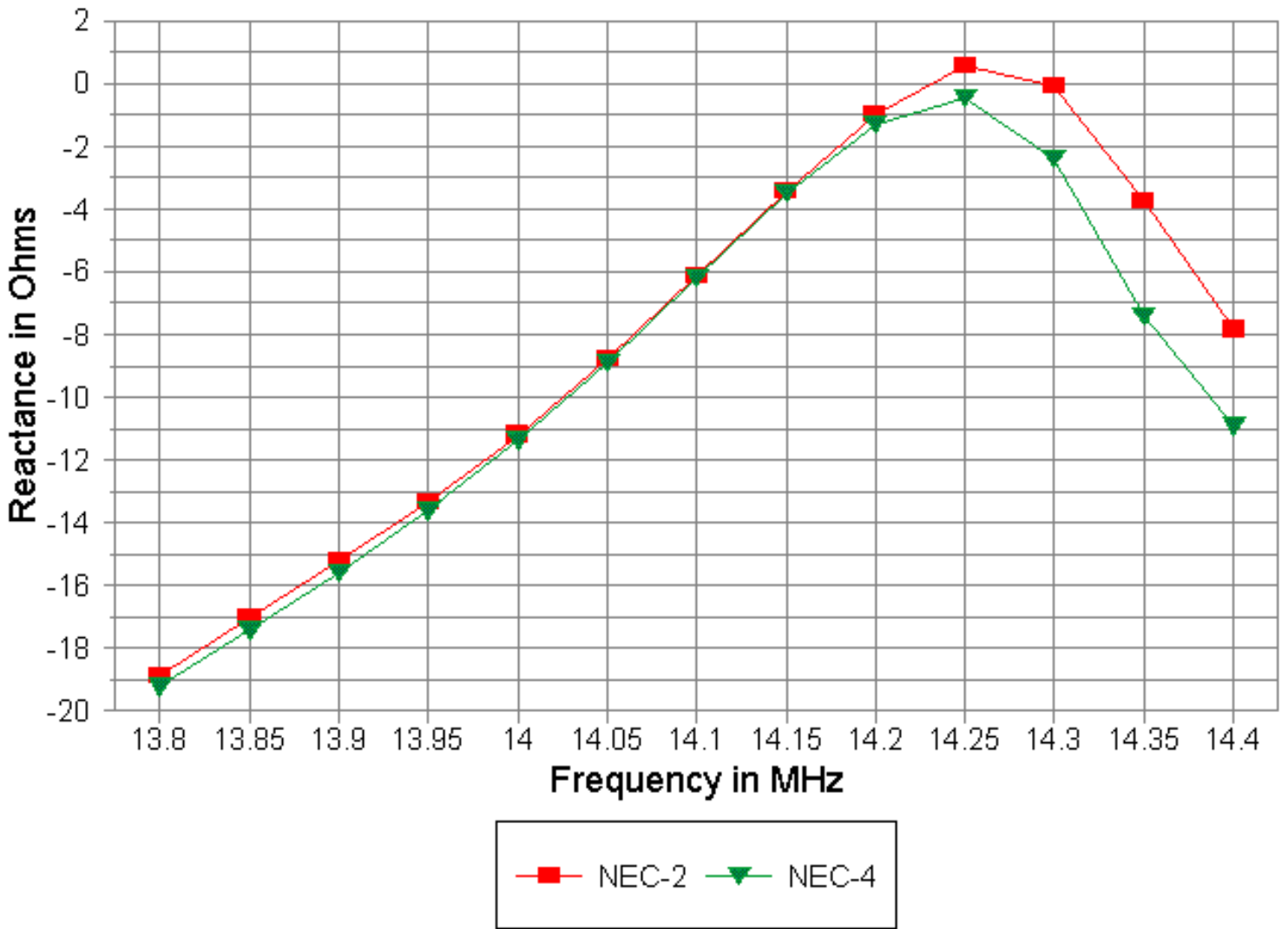

50-Ohm SWR W6NGZ 5-Element 45' Boom

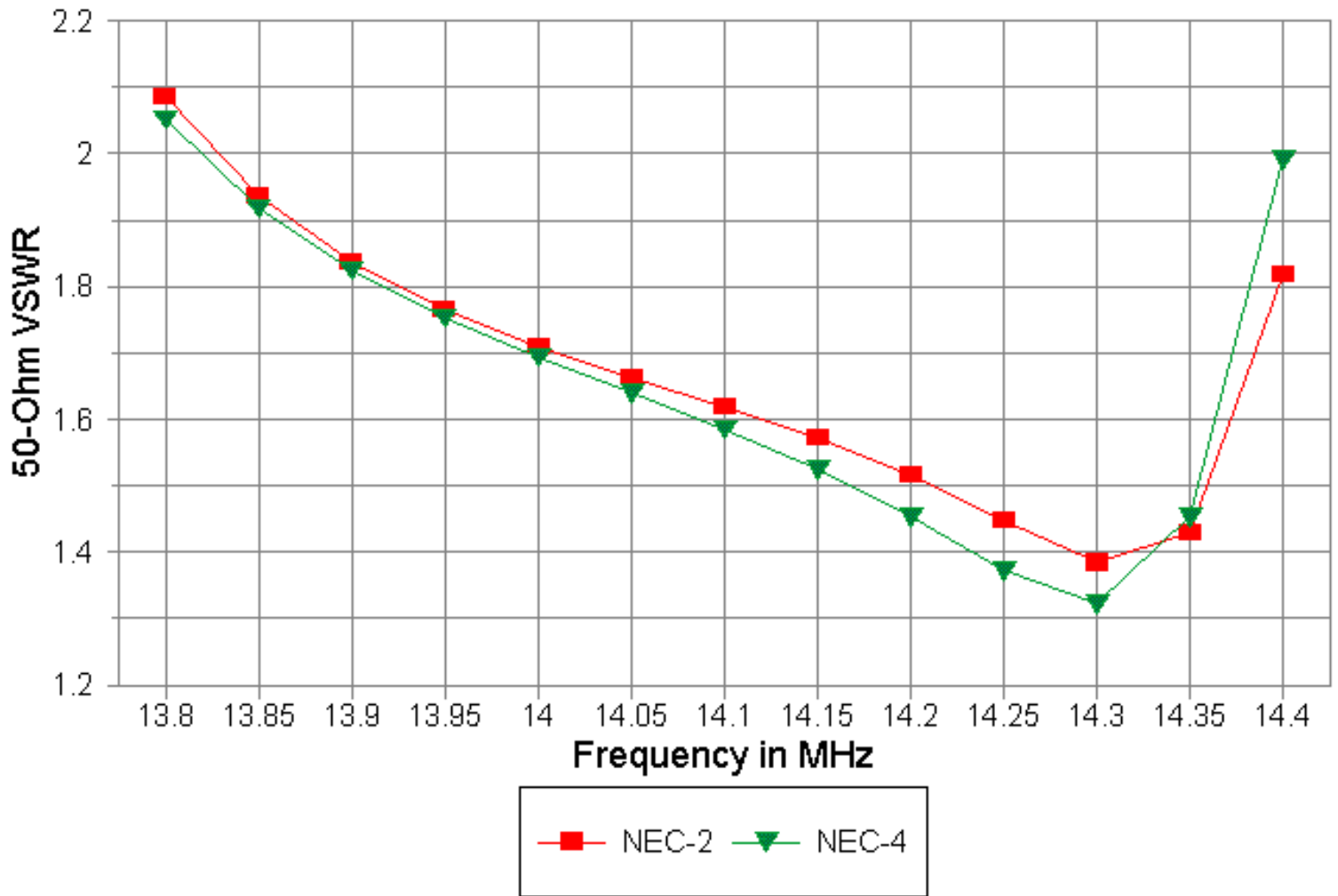

As the graphics make plain, the antenna close being a very good match for 50-ohm cable.

The K6STI 5-element, 48' boom model

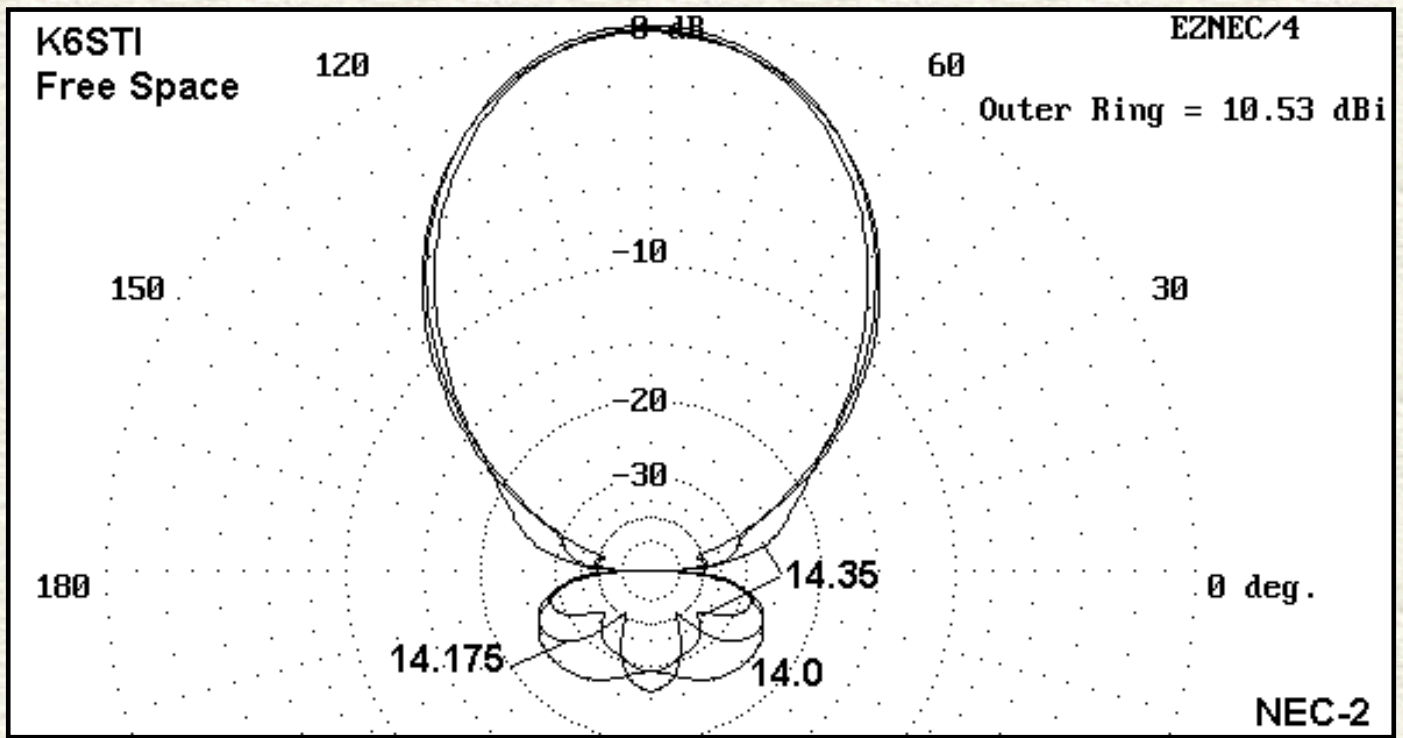

The K6STI design, with its center "bulge" in place, models quite well in NEC-2-corrected. It also displays very well the weakness of NEC-4 in dealing with the large change of diameter so close to the source or highest current point on the elements, despite extensive efforts to equalize segment lengths. NEC-4 gain data is almost a full dB higher than the more reasonable NEC-2 data, with a curve displacement lower in frequency, which also shows up on the front-to-back graph. The source resistance and reactance graphs show a similar slide, with the resistance values low in the NEC-4 run. Since current, impedance, and far field strength are related, the coincidence of these value differences from those in the NEC-2 run are not unexpected.

Free Space Gain K6STI 5-Element 48' Boom

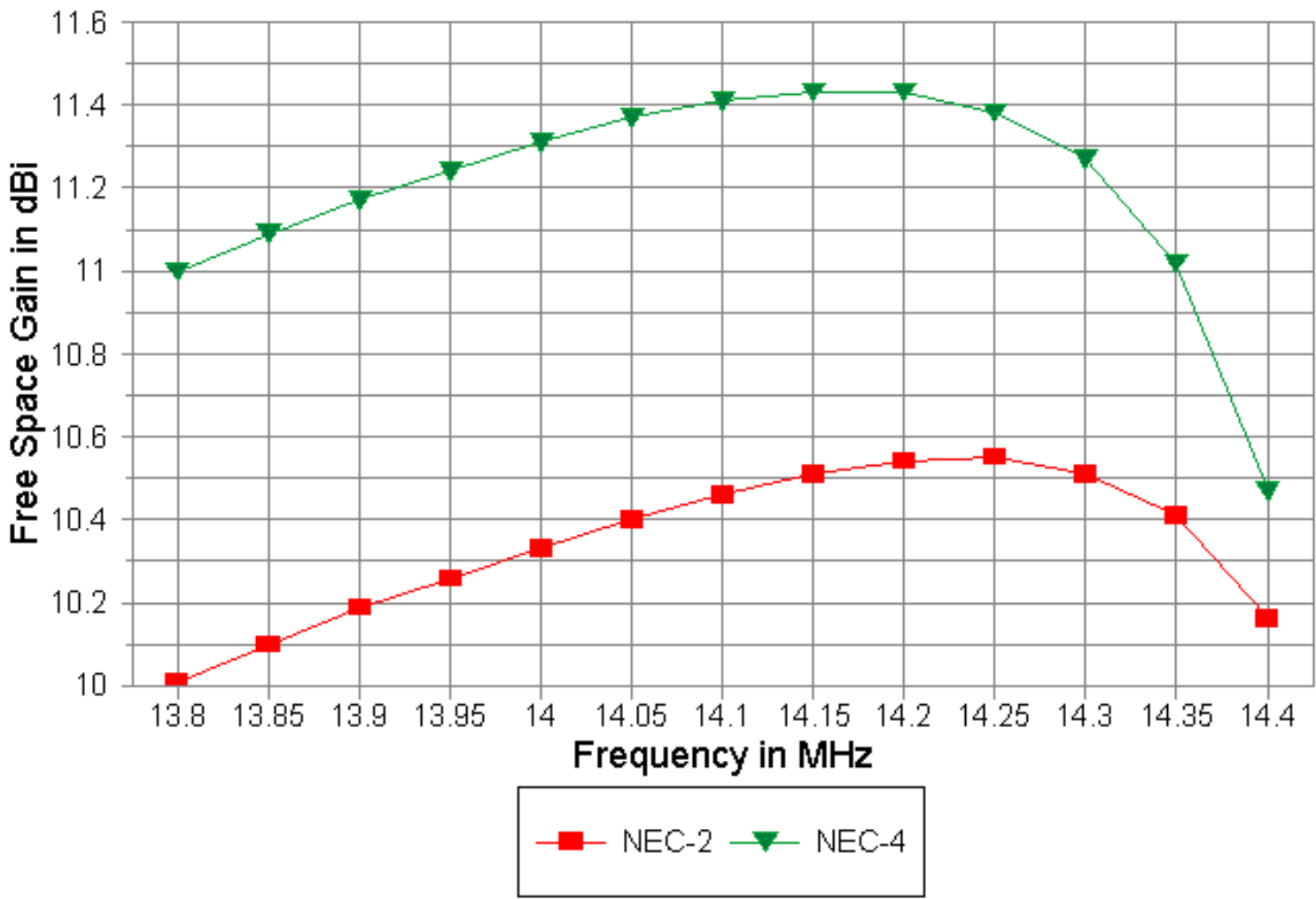

180-Degree Front-to-Back Ratio K6STI 5-Element 48' Boom

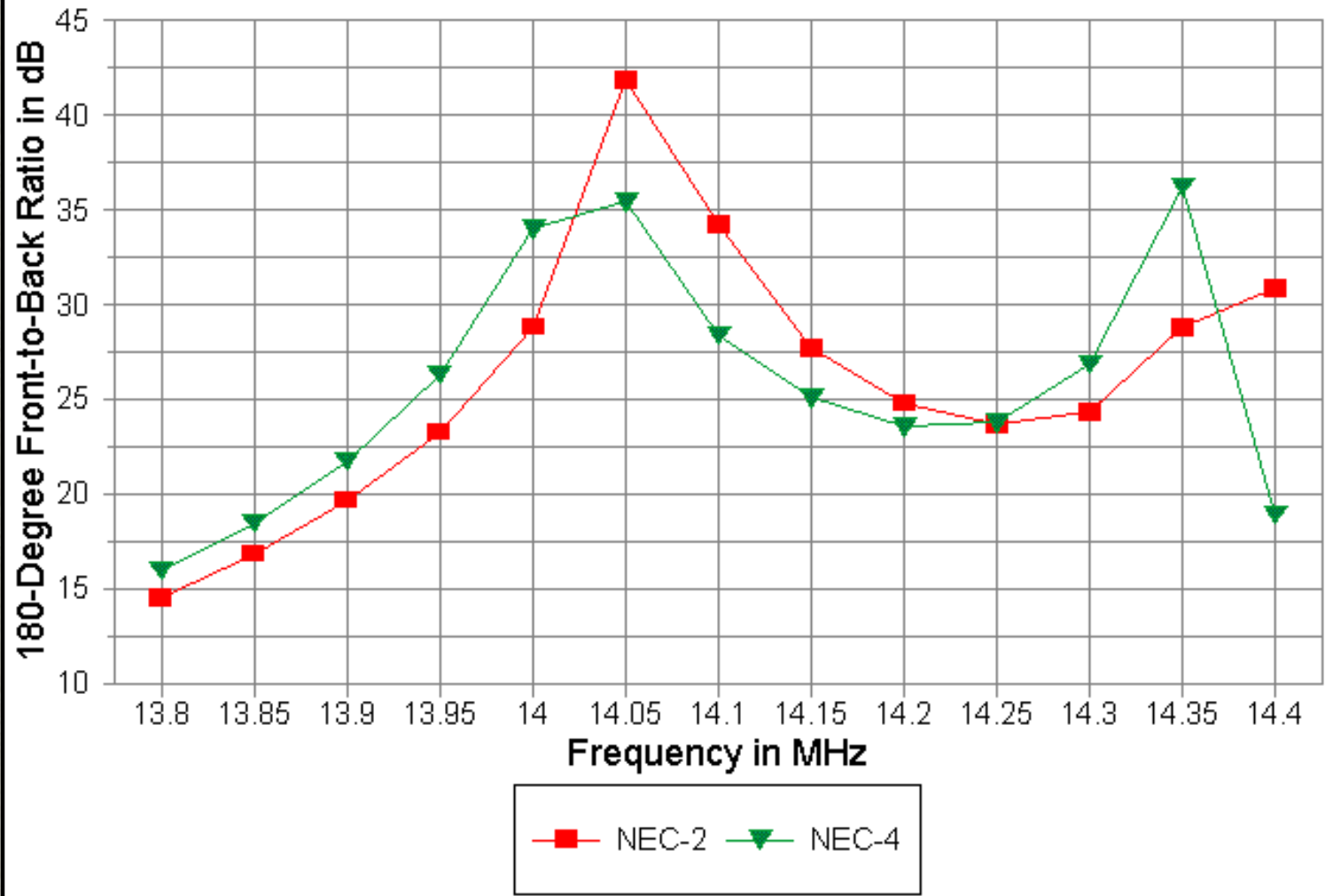

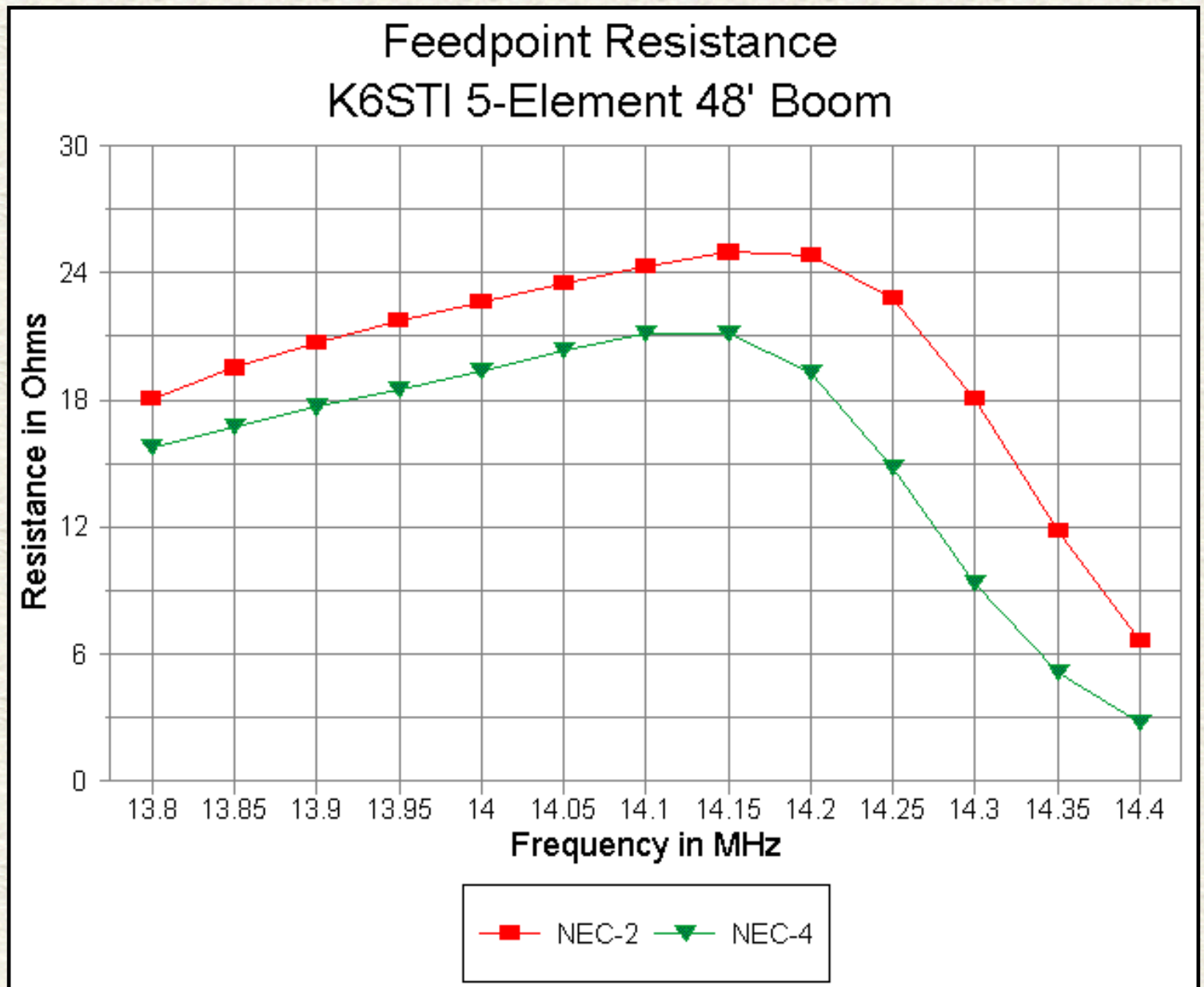

Feedpoint Reactance K6STI 5-Element 48' Boom

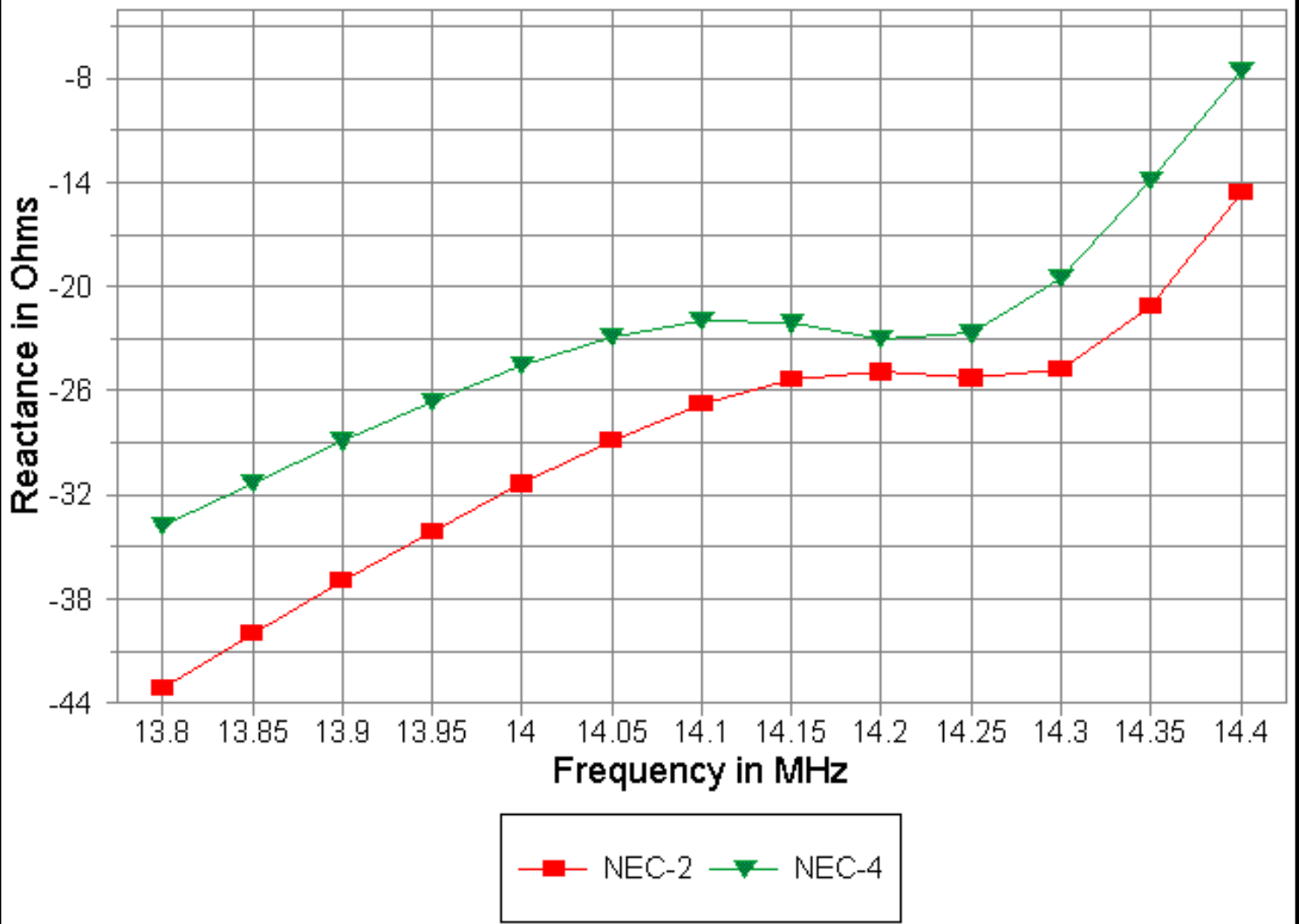

No SWR curve is shown, since the antenna is designed for a matching system such as a beta/hairpin match.

The W3LPL 5-element, 48' boom model

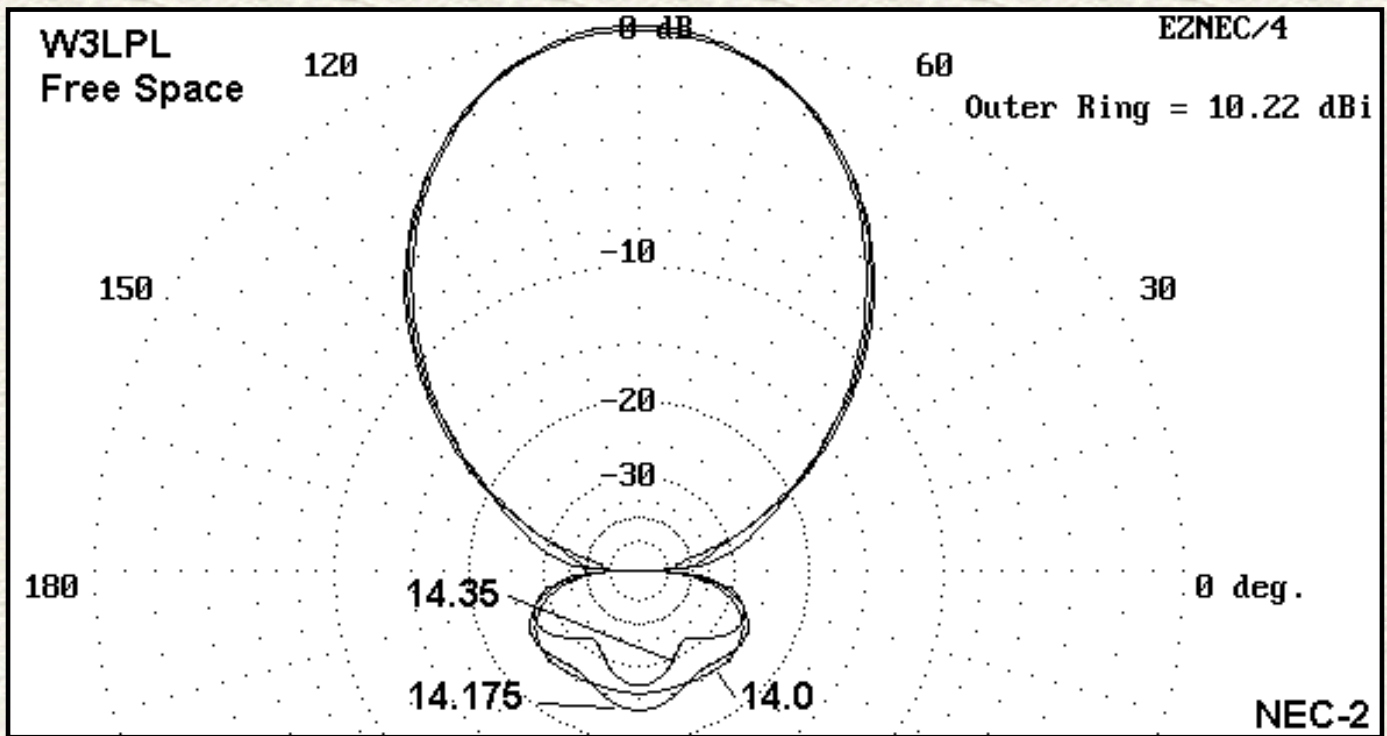

The W3LPL beam was designed for use with a Tee match, which neither NEC-2 nor NEC-4 can physically model accurately. Interestingly, W3LPL designed the antenna with non-conductive boom-to-element mounting plates in mind. Nonetheless, the curves--plus a look at the antenna characteristics just below 14 MHz--suggests that there is an approximate 50 kHz offset in frequency, with the elements in the model again playing short in the NEC-4 run, relative to the NEC-2-corrected run. Gain is still a little high in NEC-4. Given the W6NGZ model runs, this much difference is somewhat unexpected. The chief difference in the modeled data is that the W3LPL antenna shows considerable and constant inductive reactance, due to its intended use with a Tee-matching system.

Free Space Gain W3LPL 5-Element 48' Boom

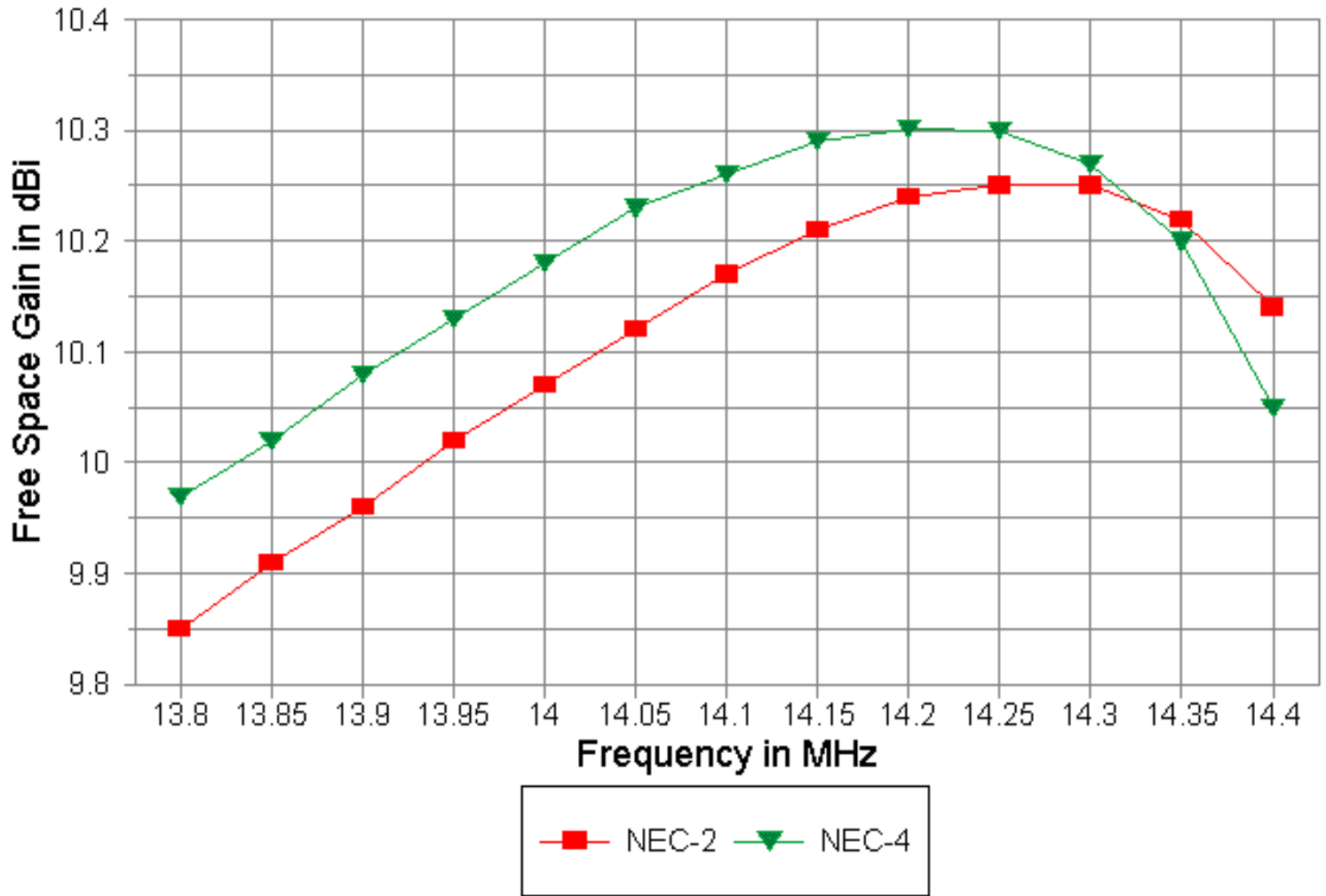

180-Degree Front-to-Back Ratio W3LPL 5-Element 48' Boom

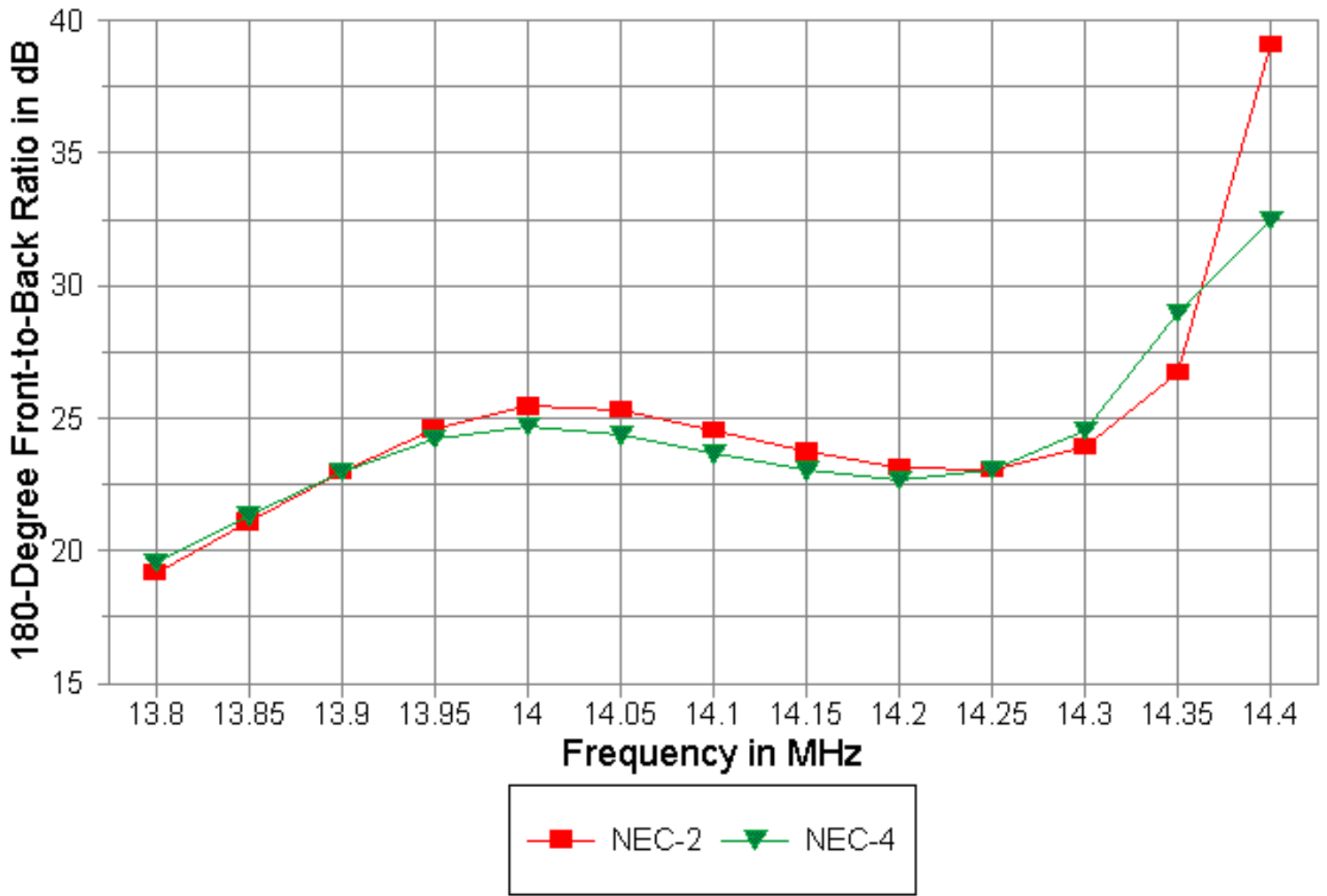

Feedpoint Resistance W3LPL 5-Element 48' Boom

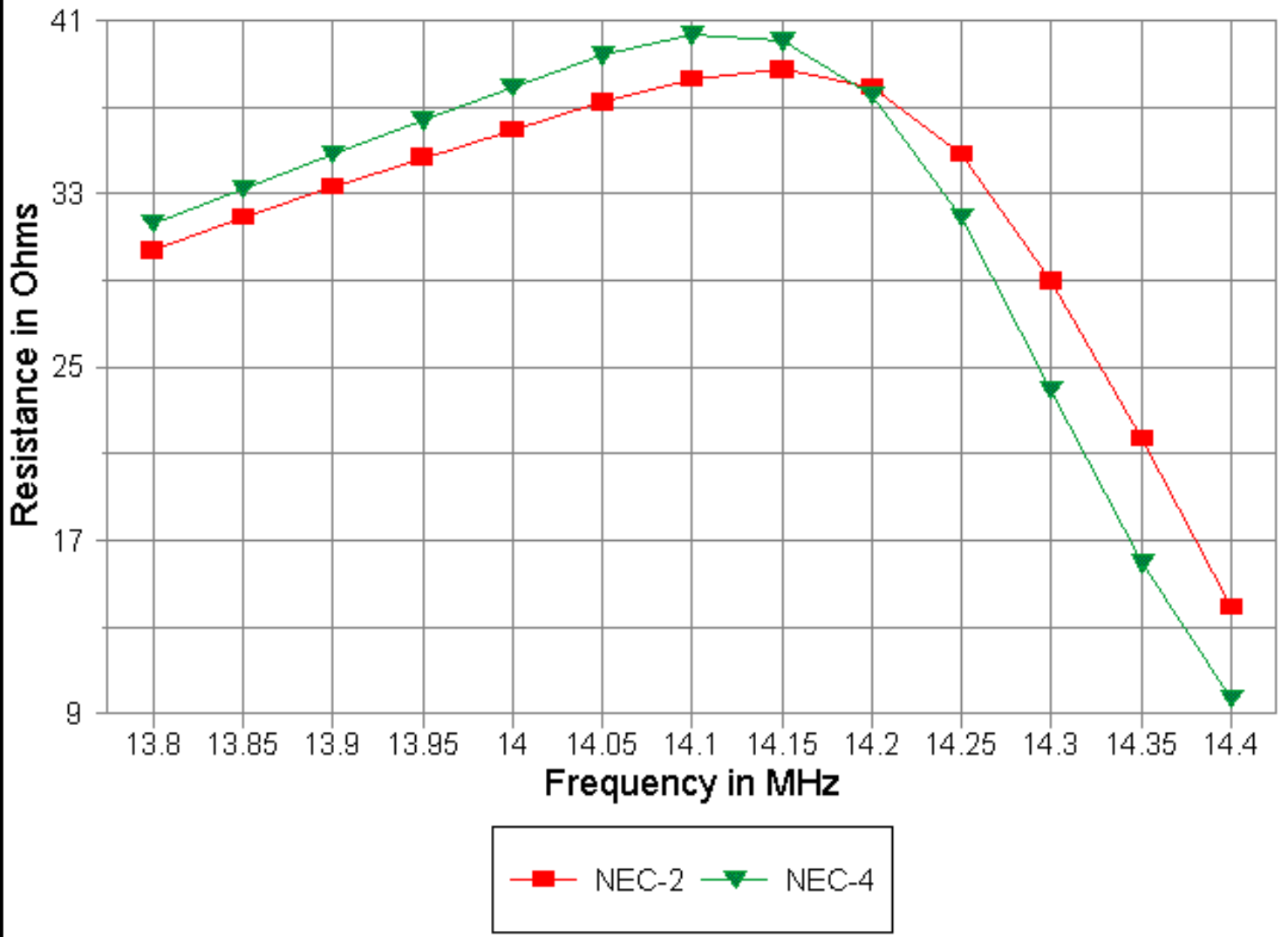

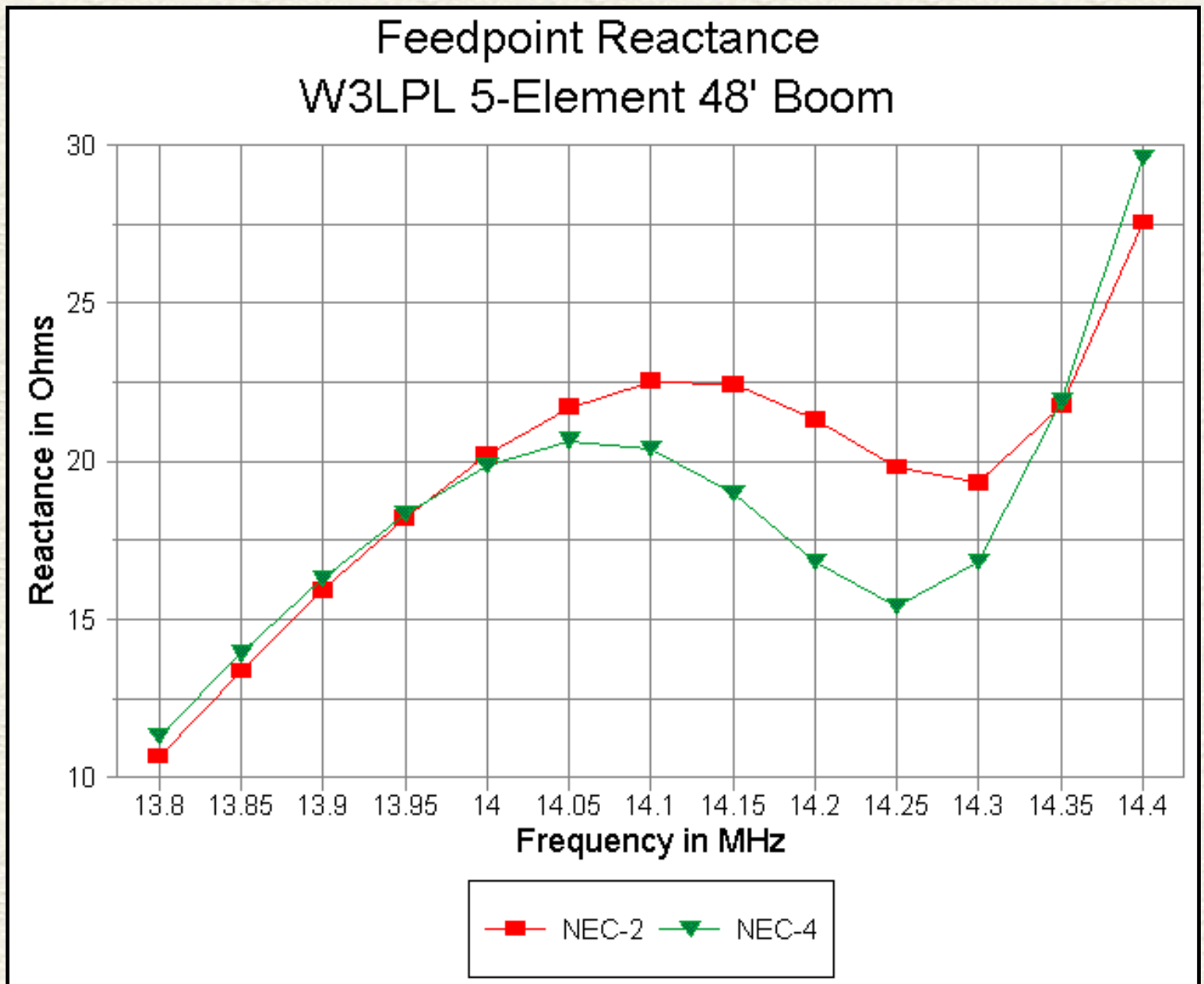

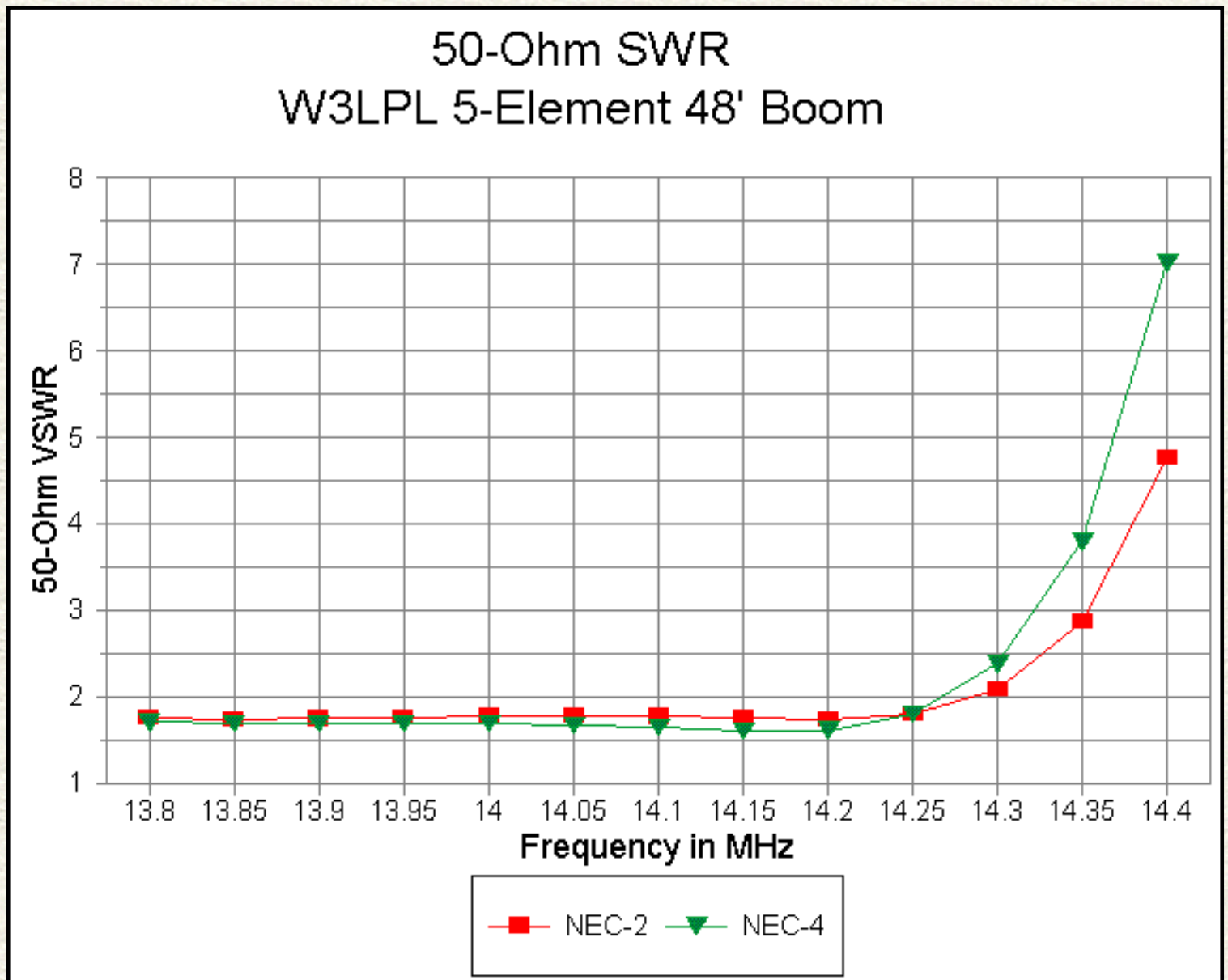

I have included the 50-Ohm SWR curve for the W3LPL antenna because it makes a good contrast with that of the W6GNZ antenna, even though the antenna designer specifically introduced the inductive reactance in the driver to set up conditions for a no-capacitor Tee match system for a 200-Ohm feed impedance. Shortening the driver to resonance in an attempt to reduce the SWR will result in a decrease in the resistive component so that no great improvement actually occurs. However, those wishing a direct 50-Ohm feed without a Tee match may wish to consider a beta match using a shunt capacitor, instead of the usual shunt inductor which is applied when the driver element is capacitively reactive. A capacitor value of about 90 Ohms reactance (about 125 pF) with sufficient voltage and current handling capabilities would come close to serving the need.

The K4SB 5-element, 55' boom model

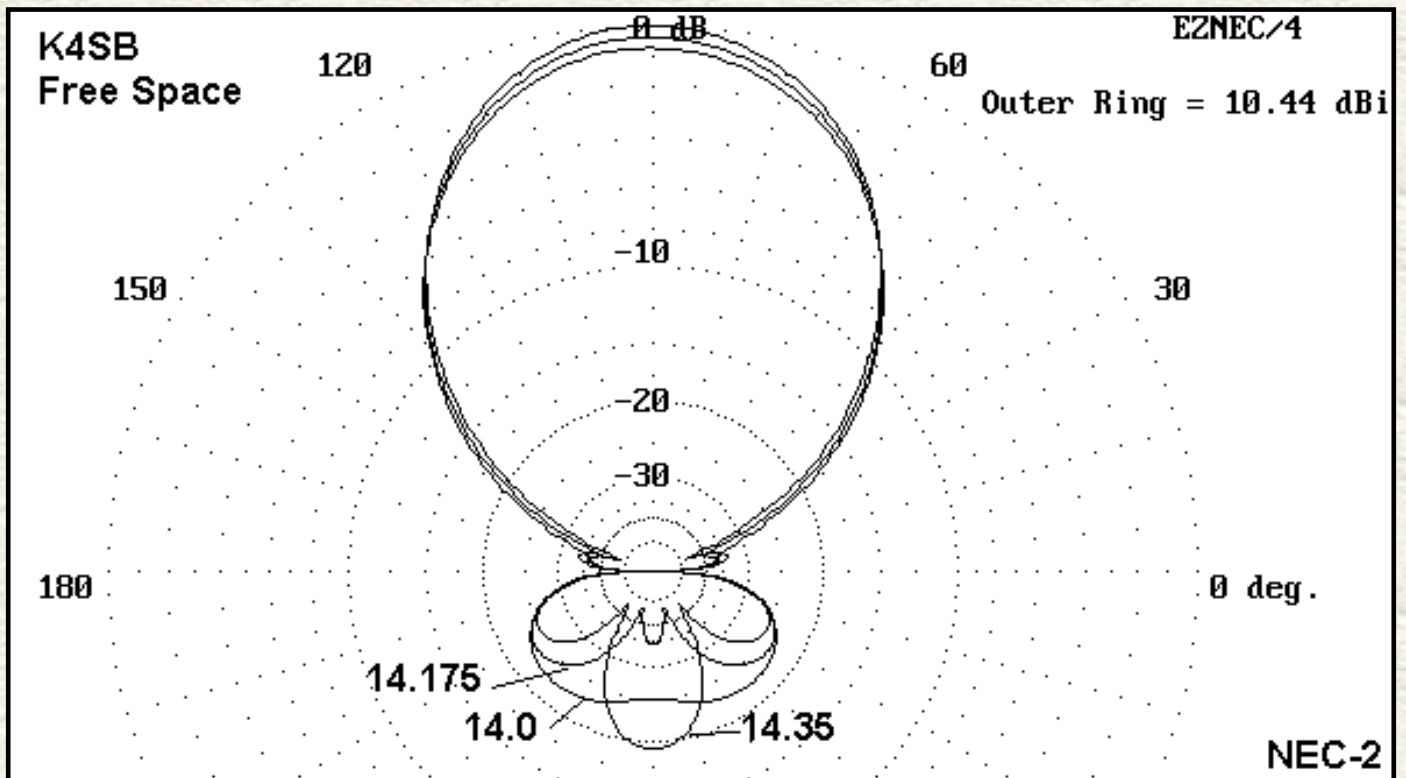

I received this model from K4SB (with whose permission it is used here) in simplified form, using monotapered elements on 10-meters. I frequency-scaled it to 20-meters and then assigned it an element taper schedule, readjusting the element lengths until it closely approximated the monotaper performance. The antenna shows the greatest gain and front-to-back differential across the band of all the models, and this exhibits the effects of using wide reflector spacing alone to raise the feedpoint impedance of the beam.

This beam is for me simply a modeling exercise and does not take into account any variations in building technique. It does not compensate for the effects of boom-to-element hardware. Considerable model tweaking would likely be required before construction.

Free Space Gain K4SB 5-Element 55' Boom

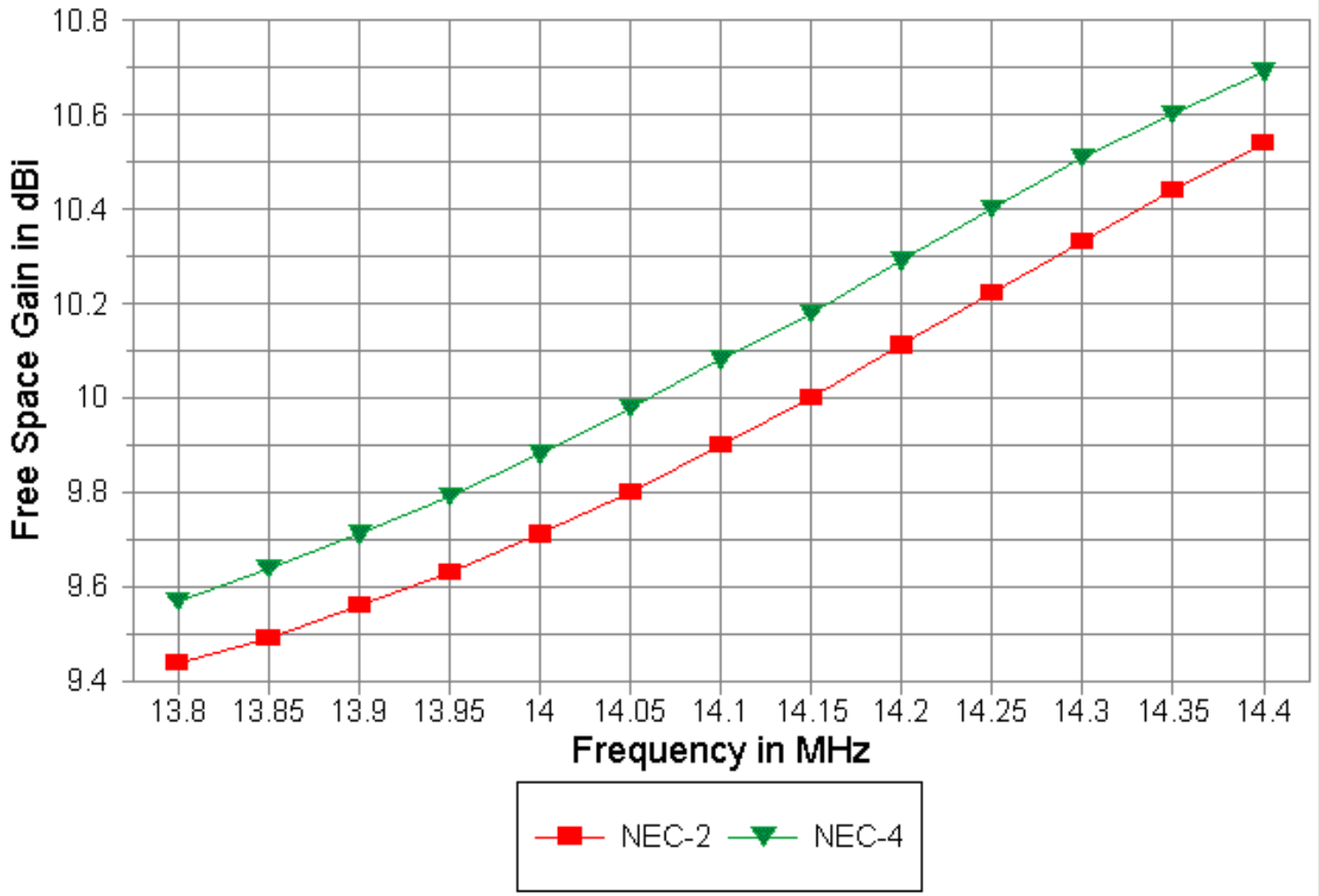

180-Degree Front-to-Back Ratio K4SB 5-Element 55' Boom

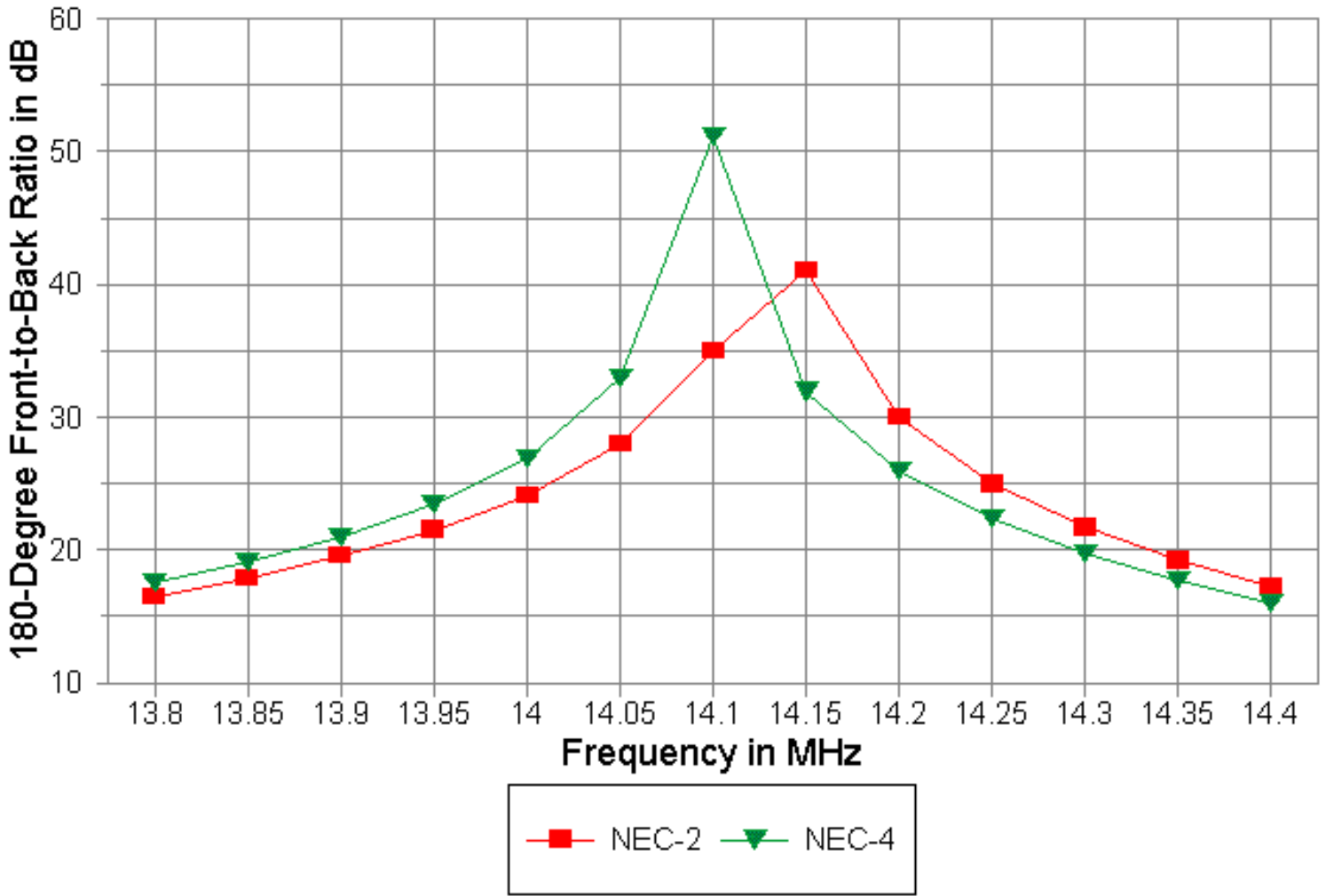

Feedpoint Resistance K4SB 5-Element 55' Boom

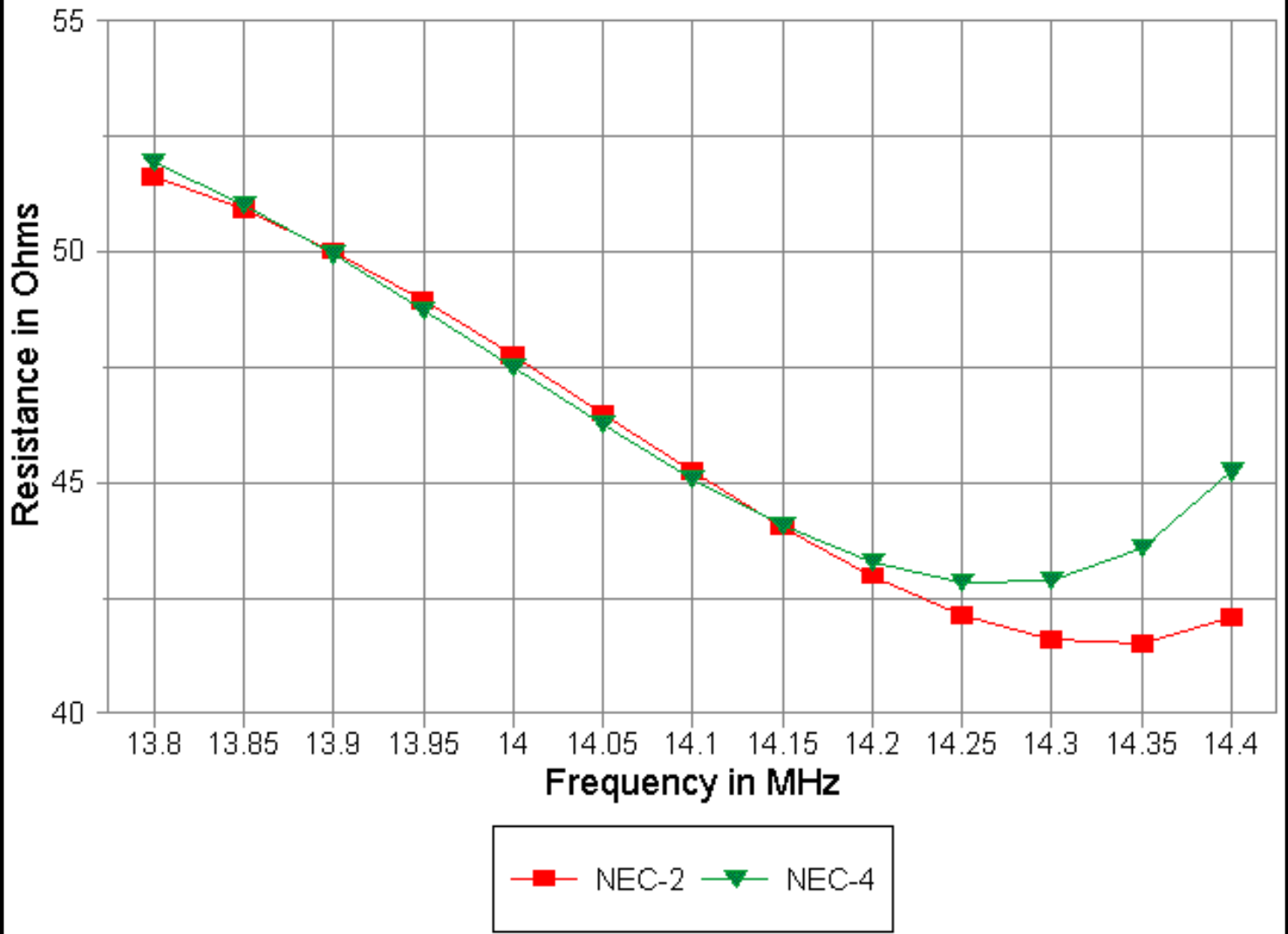

Feedpoint Reactance K4SB 5-Element 55' Boom

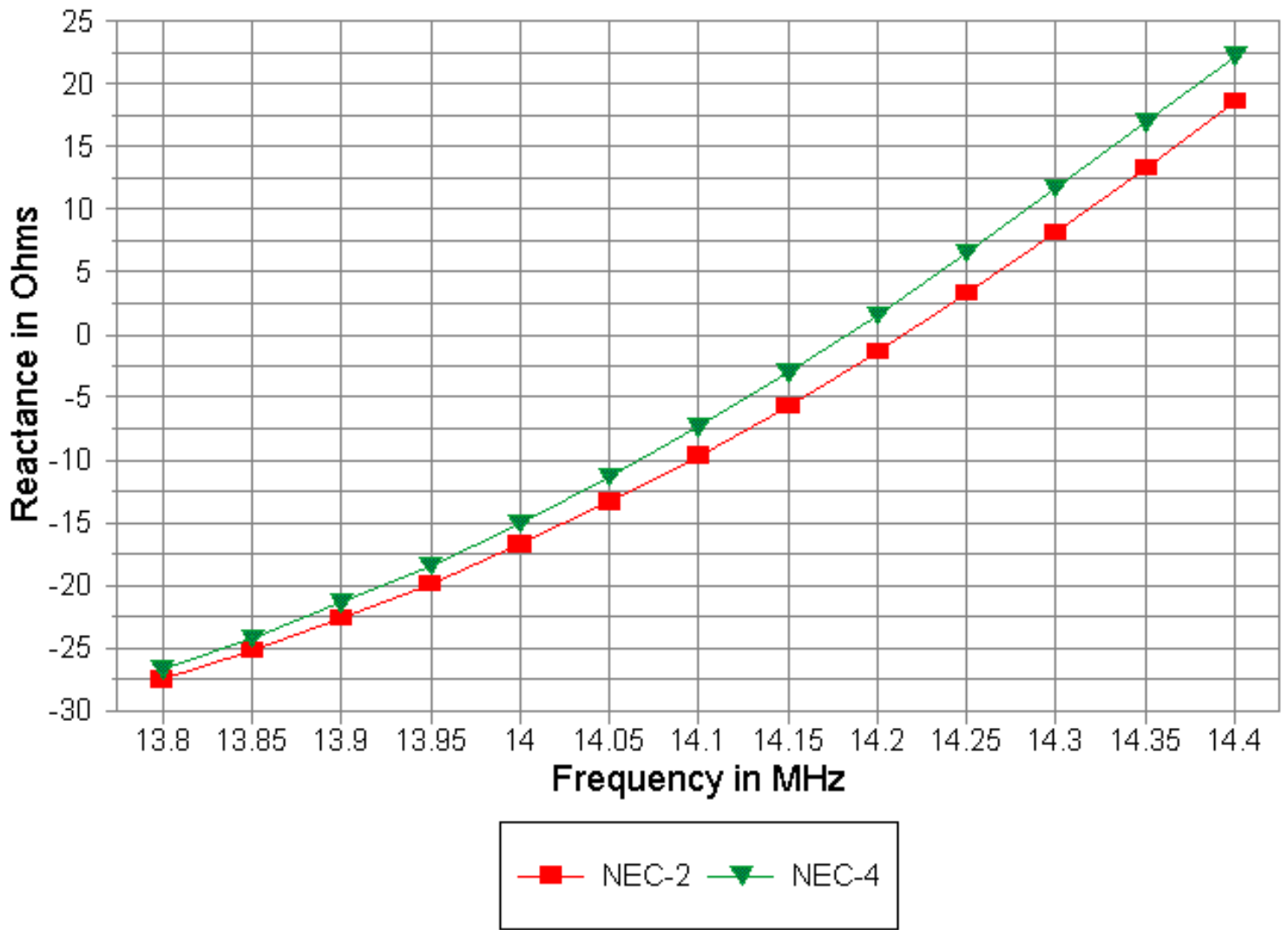

50-Ohm SWR K4SB 5-Element 55' Boom

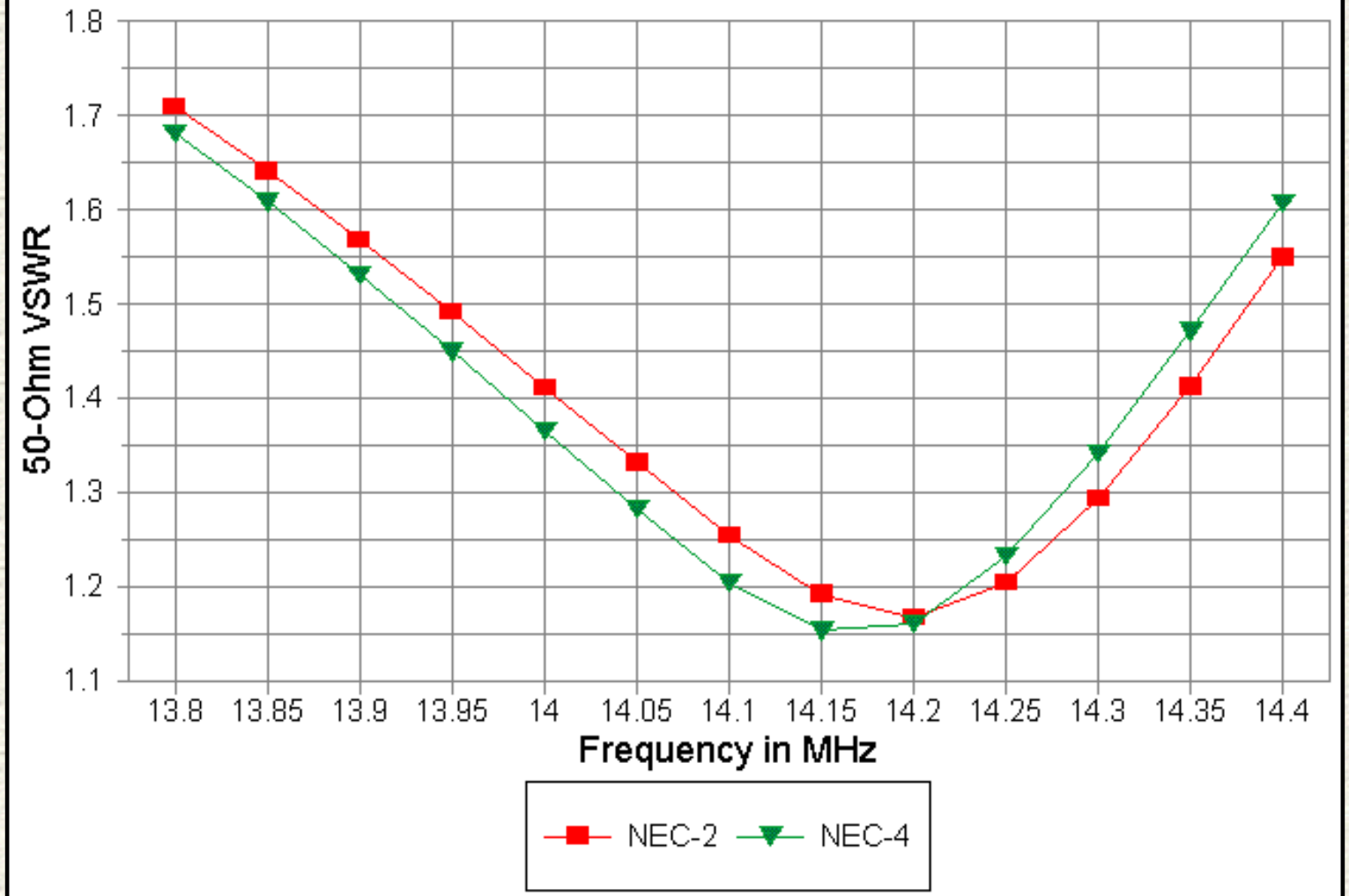

The SWR curve is quite good. There is a significant variation in reactance across the band, to go along with the variations in gain and front-to-back ratio, although the beam demonstrates close to the optimum of what may be achieved using reflector spacing alone to determine a 50-Ohm feedpoint match.

The NW3Z 6-element, 48' boom model

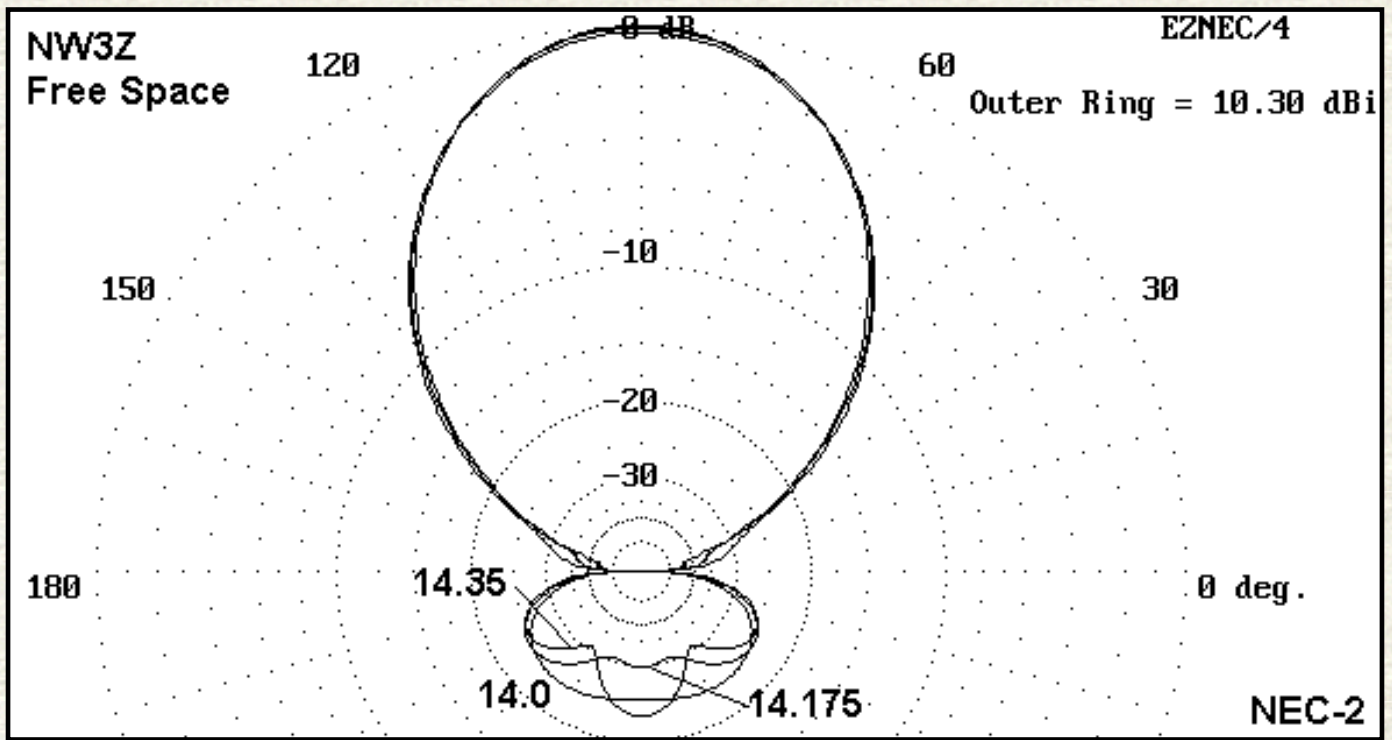

The NW3Z design adds a director close to the driven element. Along with the spacing of director D2 for impedance control and the spacing of the remaining directors for performance characteristics, this design provides a very tight near-50-Ohm feedpoint impedance with very little variation in other antenna performance characteristics across 20 meters. Indeed, everything remains stable for a little ways below the lower end of 20 meters.

As with all other designs, NEC-4 tends to overestimate gain and move the performance characteristics lower in frequency relative to NEC-2 curves. Since this model uses a 96" constant diameter center section in each element, the effect is not too extreme, but still greater than for the W6NGZ design.

Free Space Gain NW3Z 6-Element 48' Boom

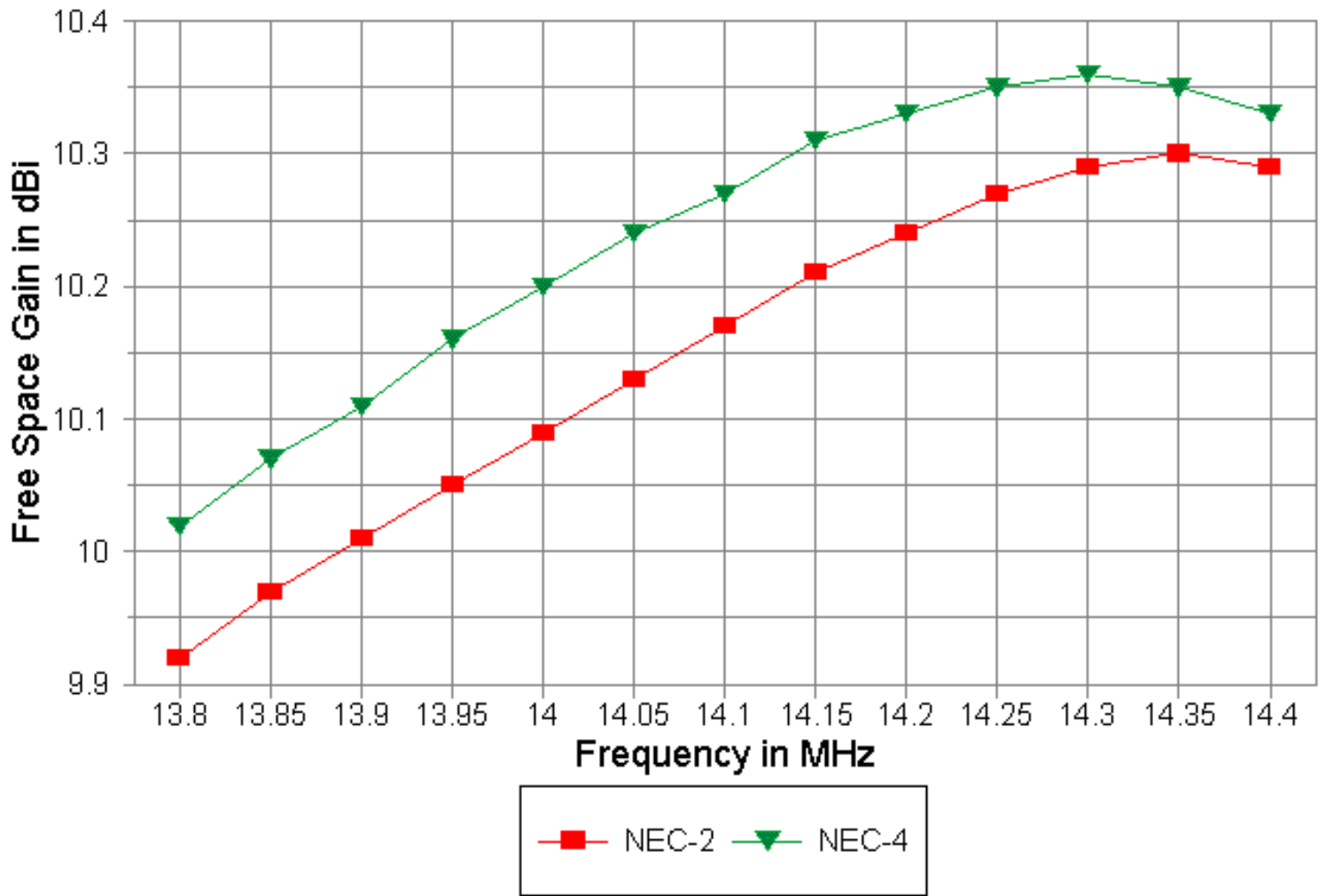

180-Degree Front-to-Back Ratio NW3Z 6-Element 48' Boom

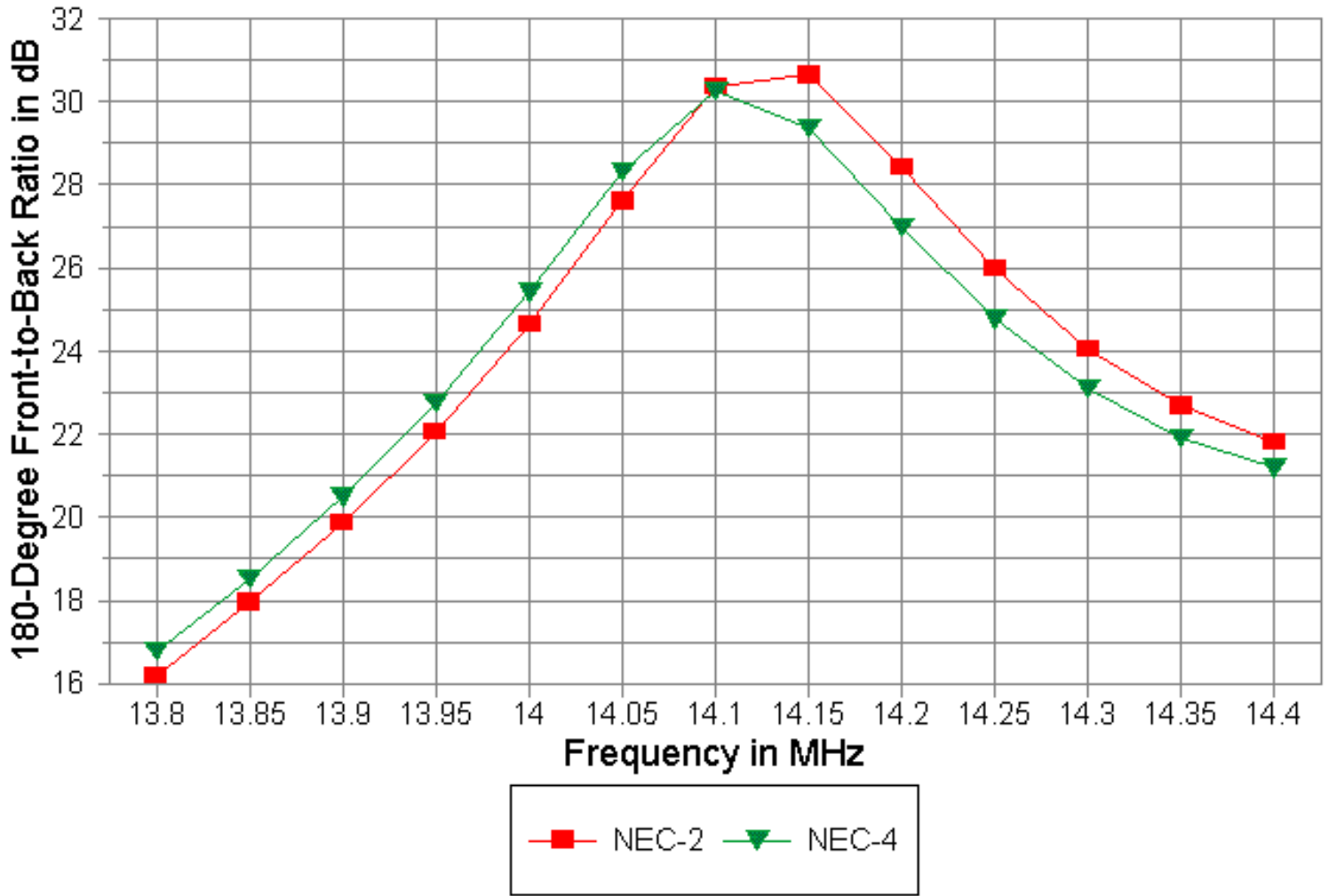

Feedpoint Resistance NW3Z 6-Element 48' Boom

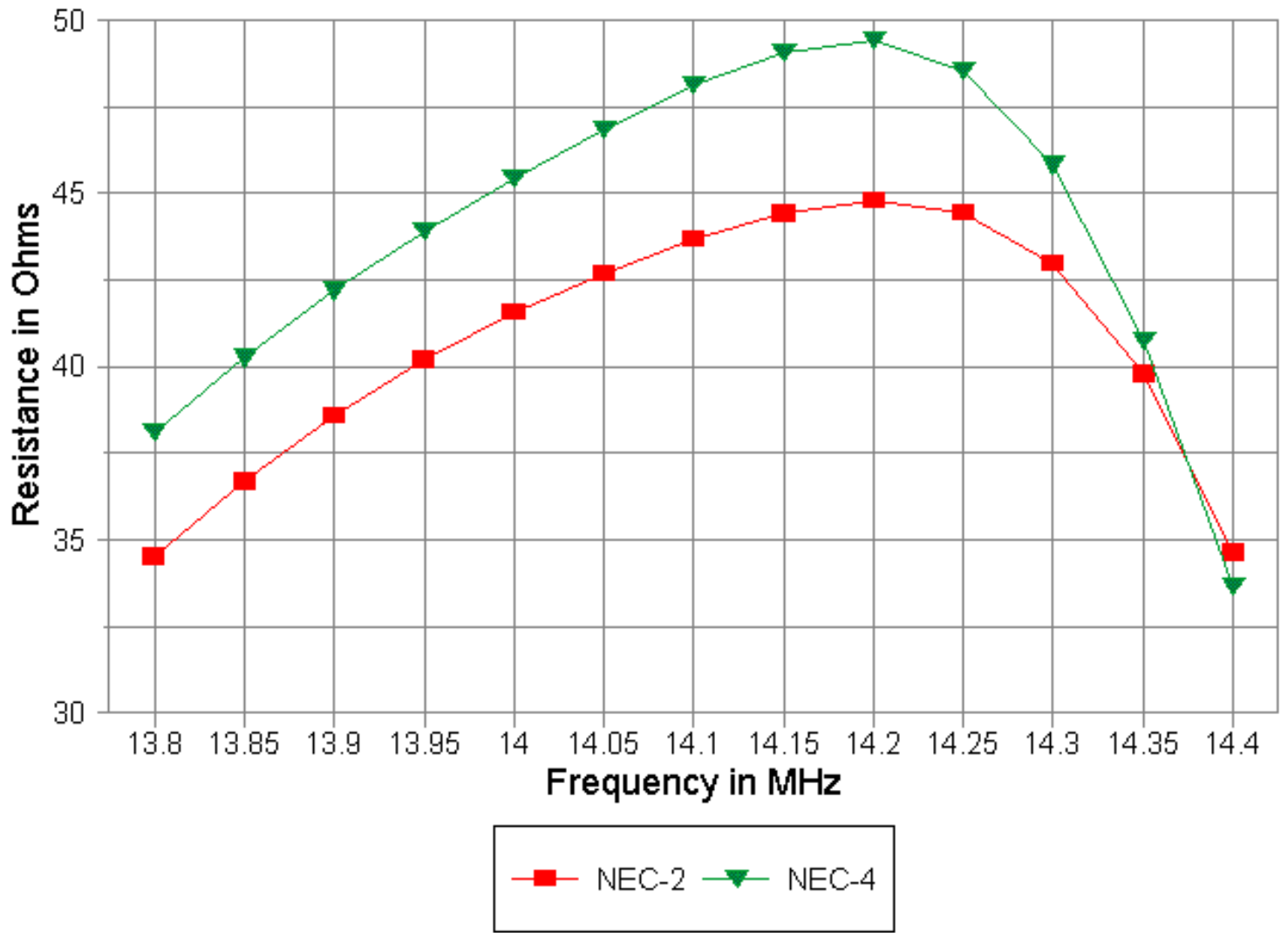

Feedpoint Reactance NW3Z 6-Element 48' Boom

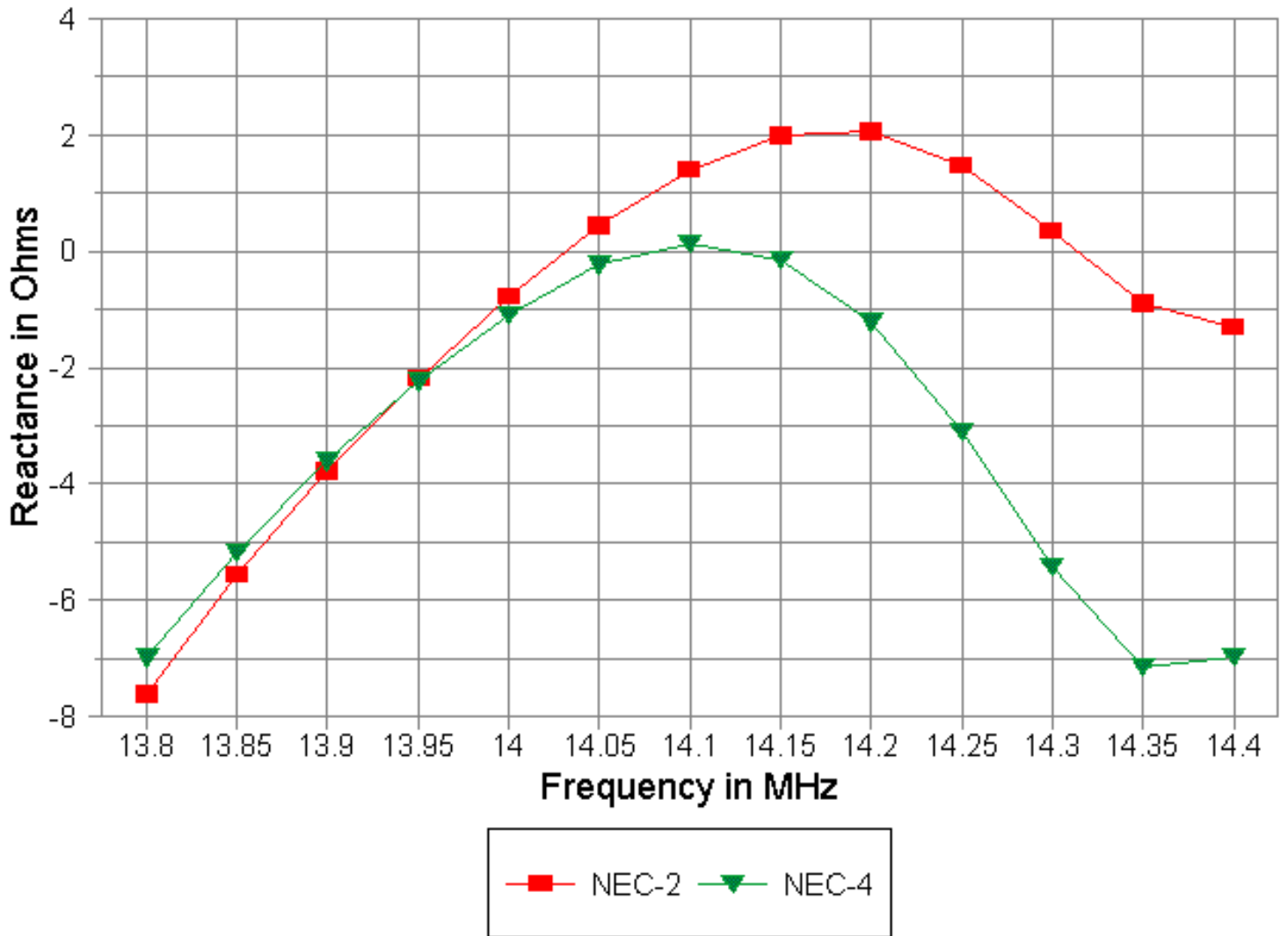

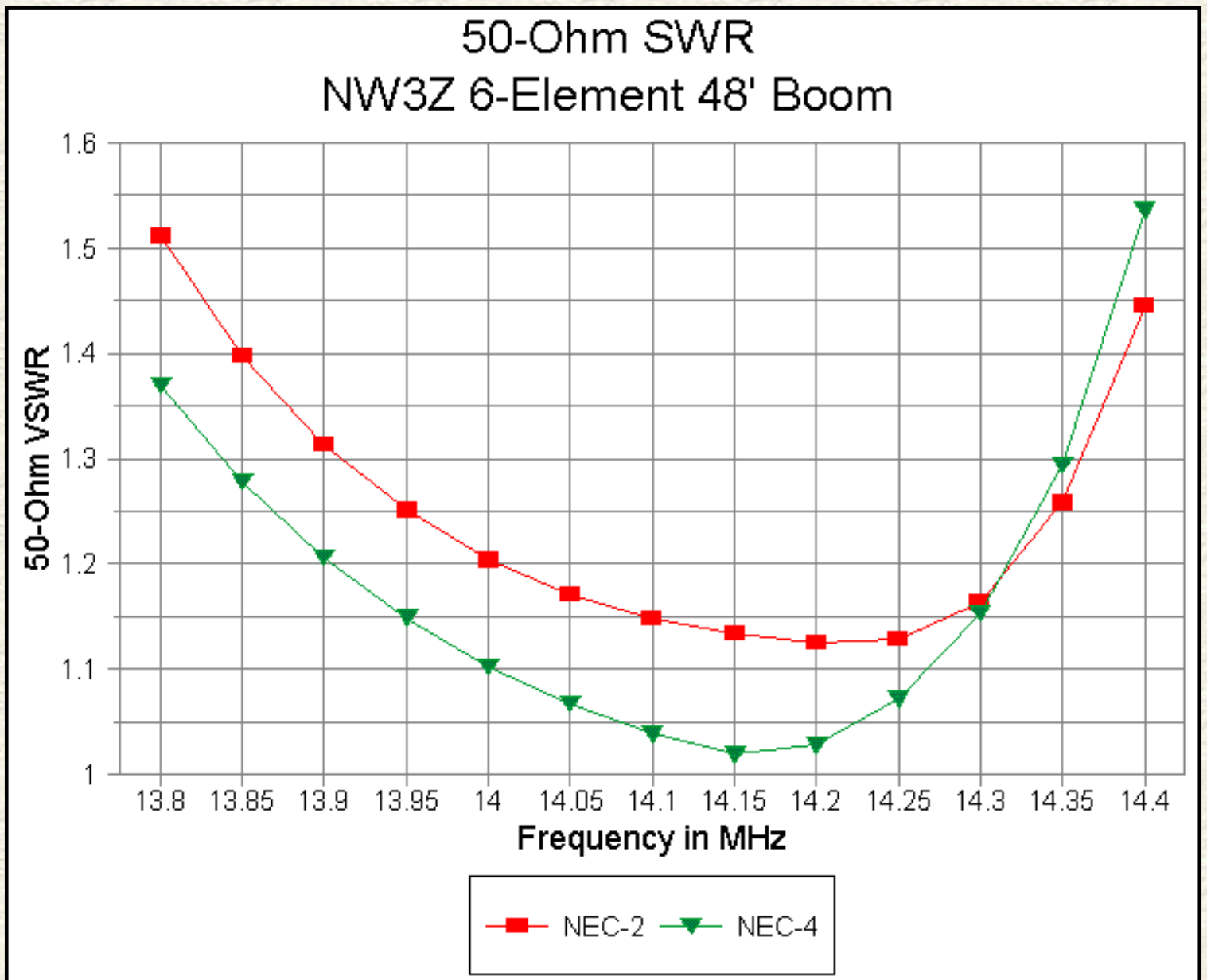

Beware of misreading the steep SWR curves: first read the axis values. Only then can you compare the numbers with those appearing in the other beam graphs.

The WB0DGF 5-element, 48' boom model

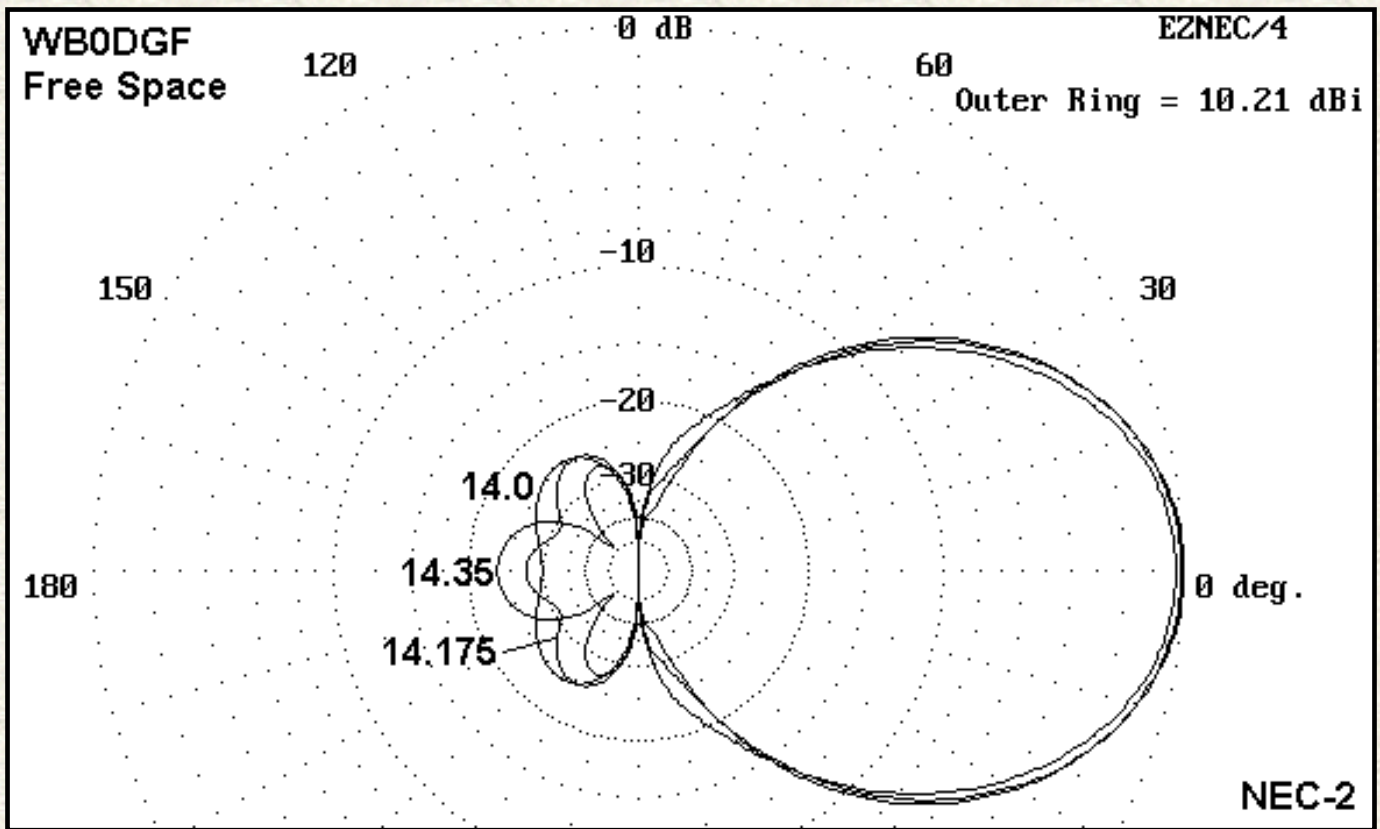

The WB0DGF design, provides an interesting contrast to both the K6STI and the NW3Z designs with respect to modeled properties. It contains center "bulge" sections that limit segment length to 8". However, these occur on only the parasitical elements. Moreover, the design uses a wider reflector spacing than some of the other designs. The result is a far less extreme overestimation of gain, but a significant shift in the NEC-4 curves lower in frequency than the NEC-2 curves. These phenomena are clear on all four of the graphs.

Since this antenna design was set up for potential use with a beta match system, no SWR curve is shown.

Free Space Gain WB0DGF 5-Element 48' Boom

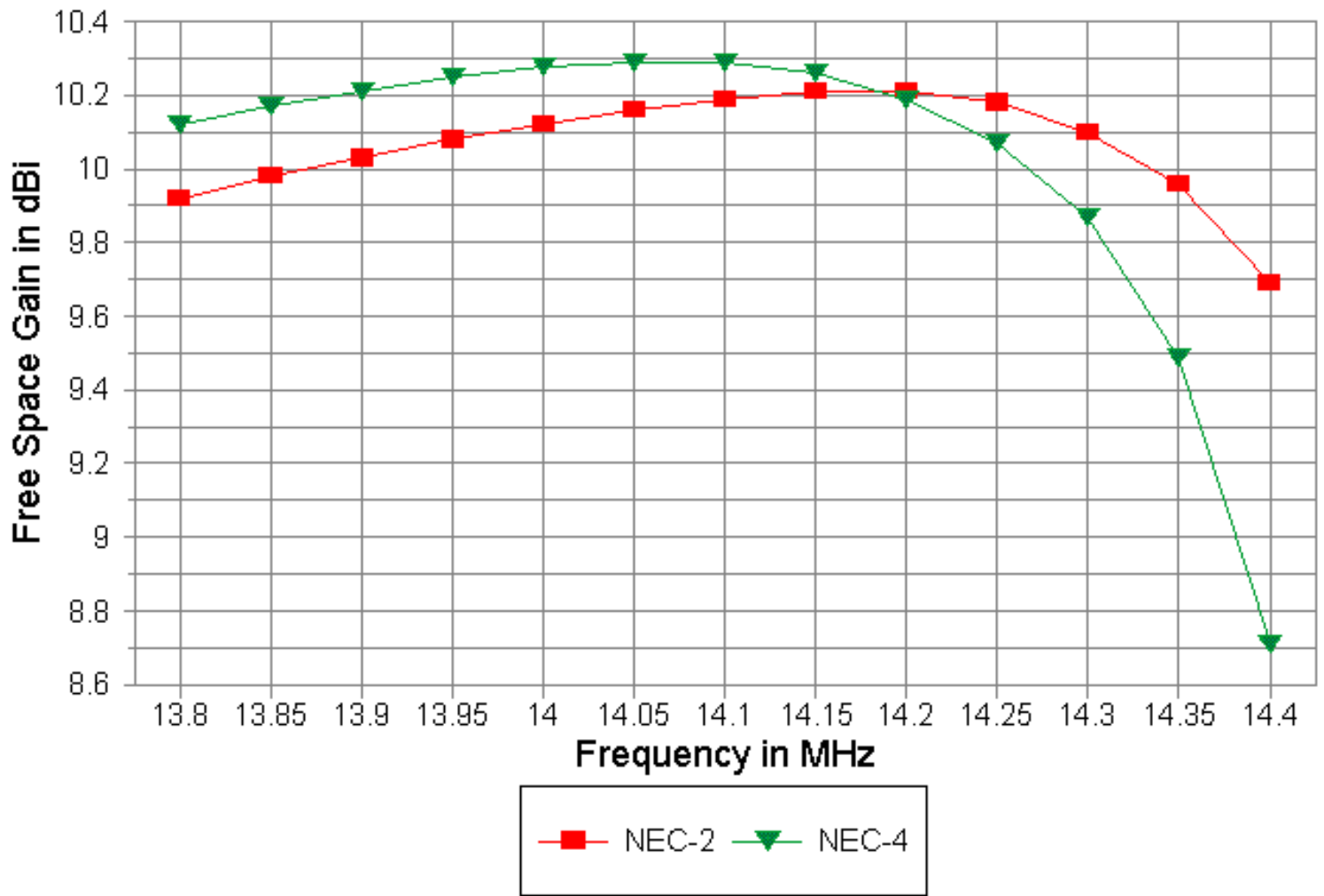

180-Degree Front-to-Back Ratio WB0DGF 5-Element 48' Boom

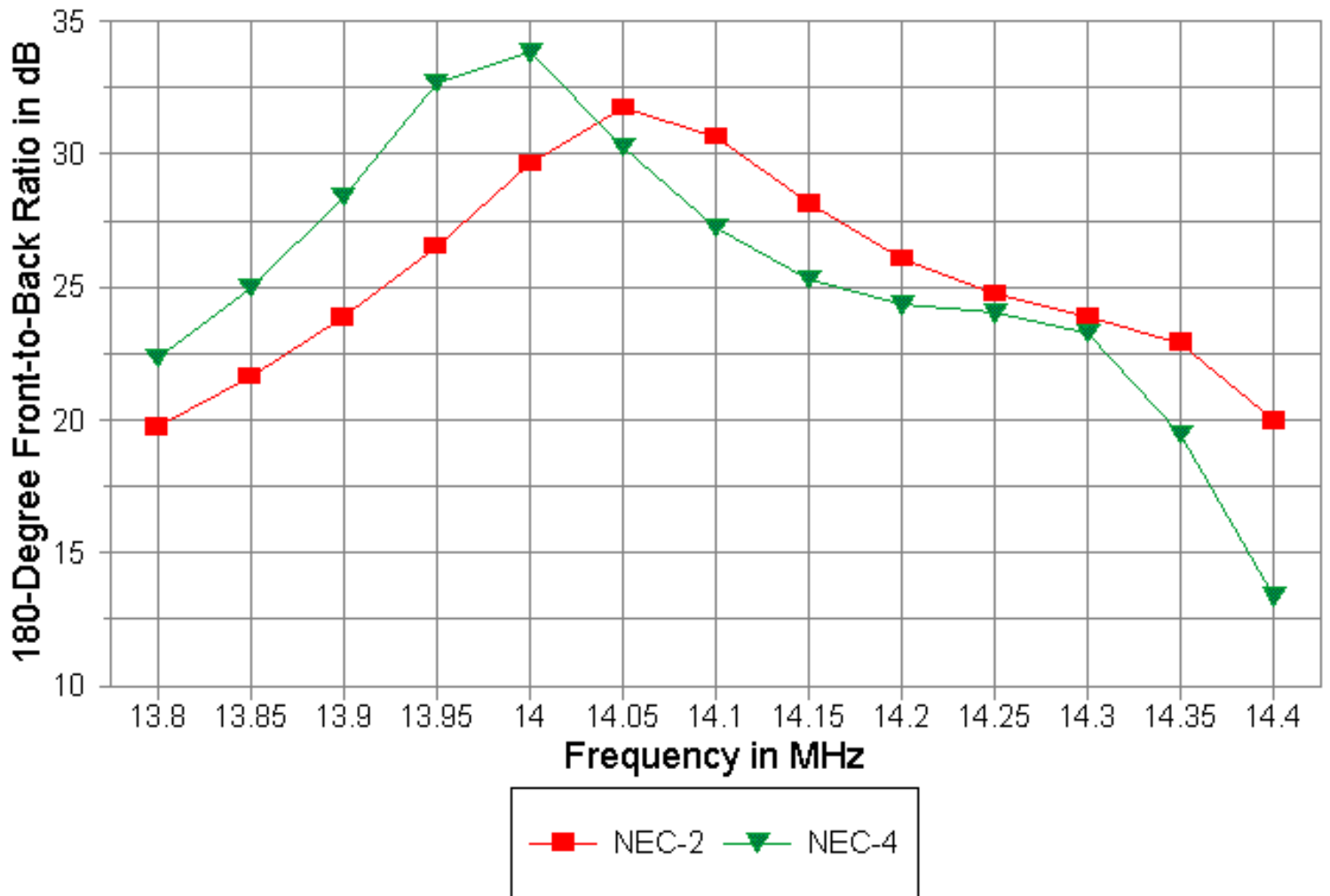

Feedpoint Resistance WB0DGF 5-Element 48' Boom

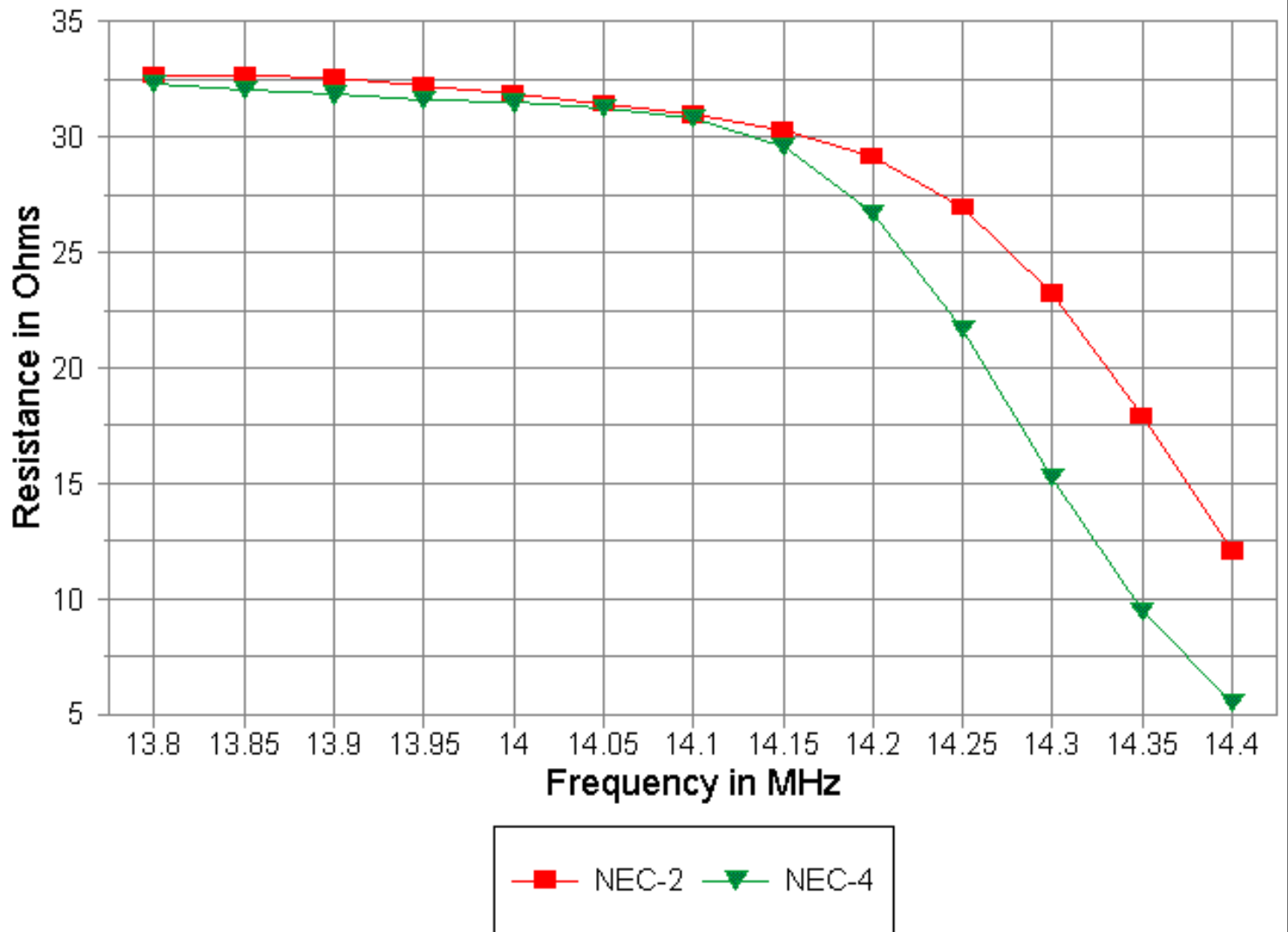

Feedpoint Reactance WB0DGF 5-Element 48' Boom

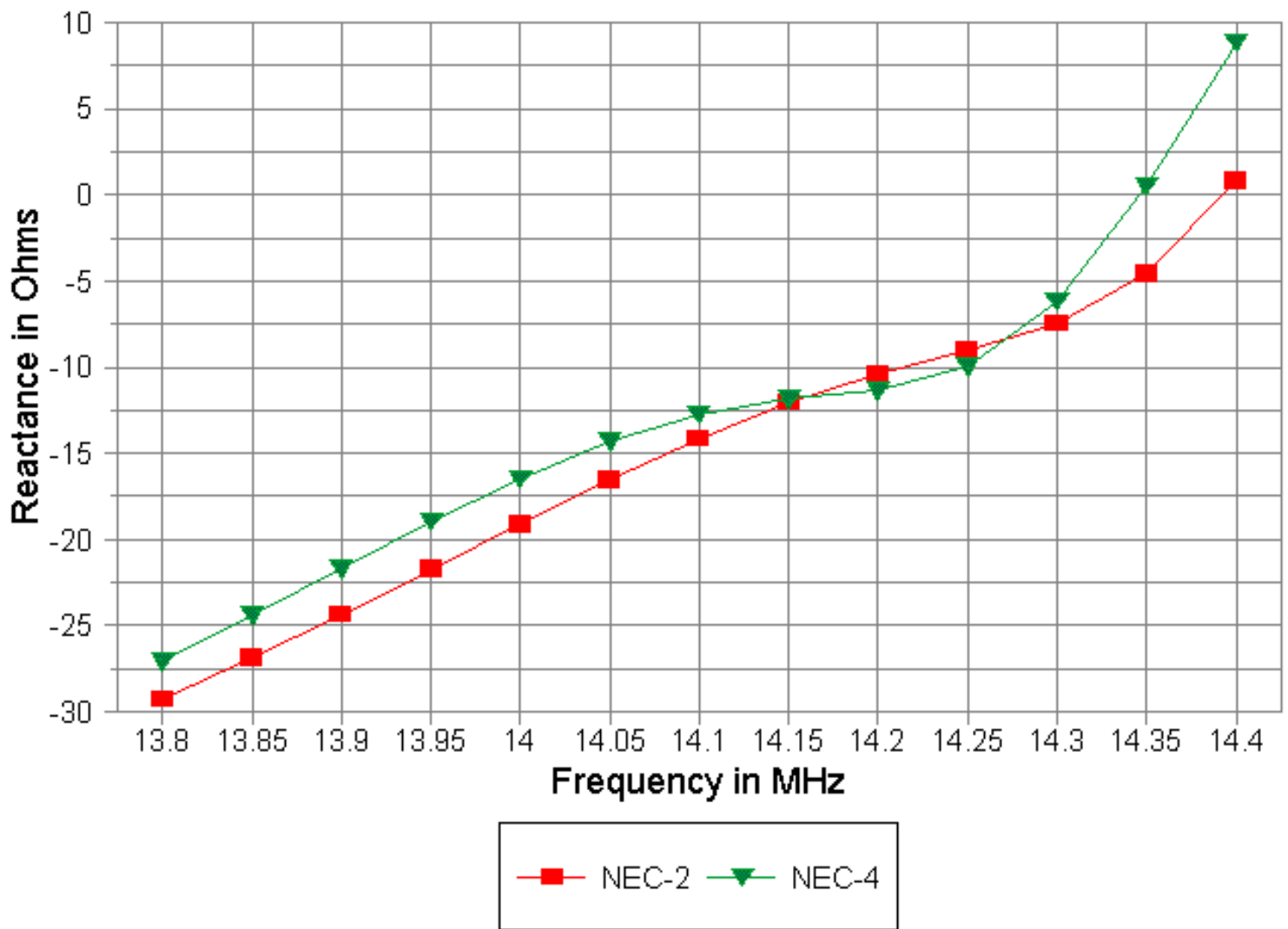

Conclusions

Because of the open questions left along the way, no evaluative assessment is warranted by this exercise alone. However, two reminders are in order.

1. The beams do reveal something of the broader aspects of large Yagi behavior in the means we use to design specific feedpoint impedances while retaining the highest levels of gain and front-to-back performance. Study of the spacing sketch alone (made more precise by the EZNEC Pro file descriptions appended to this note) may give some insight into future Yagi design directions. Yagi design innovations are far from exhausted.

2. Modeling comparisons are not to be undertaken lightly or hastily. Analyzing the foundations of received models as well as those inherent in one's own creations is a necessary step if models are to be compared against some set of design or analysis goals. It would have been very easy to see two of the designs above as simply inadequate to cover the entirety of 20 meters by looking solely at NEC-4 curves, when what is more likely at work is a frequency offset. Add to this the limitations of each core used to model the structures unambiguously, and the simple conjunction of models would become a disservice to understanding the antennas involved.

Within these handicaps, the comparison of some of the best of extant long- boom 20-meter Yagi design provides an interesting and potentially productive exercise. It can assist us in understanding both antenna design and antenna modeling just a little bit better.

EZNEC Wire Tables for the 5 Yagis

EZNEC/4 ver. 2.0

5L45' W6NGZ CQ 10-96 p 22

07-19-1998

07:44:08

Frequency = 14.175 MHz.

Wire Loss: Aluminum -- Resistivity = 4E-08 ohm-m, Rel. Perm. = 1

----- WIRES -----

| Wire | Conn. | --- End 1 (x,y,z : in) | Conn. | --- End 2 (x,y,z : in) | Dia(in) | Segs |
|------|-------|------------------------|-------|------------------------|----------|------|
| 1 | | -215.60, 0.000, 0.000 | W2E1 | -156.00, 0.000, 0.000 | 6.25E-01 | 5 |
| 2 | W1E2 | -156.00, 0.000, 0.000 | W3E1 | -120.00, 0.000, 0.000 | 7.50E-01 | 3 |
| 3 | W2E2 | -120.00, 0.000, 0.000 | W4E1 | -72.000, 0.000, 0.000 | 8.75E-01 | 4 |
| 4 | W3E2 | -72.000, 0.000, 0.000 | W5E1 | 72.000, 0.000, 0.000 | 1.00E+00 | 13 |
| 5 | W4E2 | 72.000, 0.000, 0.000 | W6E1 | 120.000, 0.000, 0.000 | 8.75E-01 | 4 |
| 6 | W5E2 | 120.000, 0.000, 0.000 | W7E1 | 156.000, 0.000, 0.000 | 7.50E-01 | 3 |
| 7 | W6E2 | 156.000, 0.000, 0.000 | | 215.605, 0.000, 0.000 | 6.25E-01 | 5 |
| 8 | | -205.95, 79.800, 0.000 | W9E1 | -156.00, 79.800, 0.000 | 6.25E-01 | 4 |
| 9 | W8E2 | -156.00, 79.800, 0.000 | W10E1 | -120.00, 79.800, 0.000 | 7.50E-01 | 3 |
| 10 | W9E2 | -120.00, 79.800, 0.000 | W11E1 | -72.000, 79.800, 0.000 | 8.75E-01 | 4 |
| 11 | W10E2 | -72.000, 79.800, 0.000 | W12E1 | 72.000, 79.800, 0.000 | 1.00E+00 | 13 |
| 12 | W11E2 | 72.000, 79.800, 0.000 | W13E1 | 120.000, 79.800, 0.000 | 8.75E-01 | 4 |
| 13 | W12E2 | 120.000, 79.800, 0.000 | W14E1 | 156.000, 79.800, 0.000 | 7.50E-01 | 3 |
| 14 | W13E2 | 156.000, 79.800, 0.000 | | 205.950, 79.800, 0.000 | 6.25E-01 | 4 |
| 15 | | -198.21,155.160, 0.000 | W16E1 | -156.00,155.160, 0.000 | 6.25E-01 | 4 |
| 16 | W15E2 | -156.00,155.160, 0.000 | W17E1 | -120.00,155.160, 0.000 | 7.50E-01 | 3 |
| 17 | W16E2 | -120.00,155.160, 0.000 | W18E1 | -72.000,155.160, 0.000 | 8.75E-01 | 4 |
| 18 | W17E2 | -72.000,155.160, 0.000 | W19E1 | 72.000,155.160, 0.000 | 1.00E+00 | 13 |
| 19 | W18E2 | 72.000,155.160, 0.000 | W20E1 | 120.000,155.160, 0.000 | 8.75E-01 | 4 |
| 20 | W19E2 | 120.000,155.160, 0.000 | W21E1 | 156.000,155.160, 0.000 | 7.50E-01 | 3 |
| 21 | W20E2 | 156.000,155.160, 0.000 | | 198.209,155.160, 0.000 | 6.25E-01 | 4 |
| 22 | | -196.55,337.920, 0.000 | W23E1 | -156.00,337.920, 0.000 | 6.25E-01 | 3 |
| 23 | W22E2 | -156.00,337.920, 0.000 | W24E1 | -120.00,337.920, 0.000 | 7.50E-01 | 3 |
| 24 | W23E2 | -120.00,337.920, 0.000 | W25E1 | -72.000,337.920, 0.000 | 8.75E-01 | 4 |
| 25 | W24E2 | -72.000,337.920, 0.000 | W26E1 | 72.000,337.920, 0.000 | 1.00E+00 | 13 |
| 26 | W25E2 | 72.000,337.920, 0.000 | W27E1 | 120.000,337.920, 0.000 | 8.75E-01 | 4 |
| 27 | W26E2 | 120.000,337.920, 0.000 | W28E1 | 156.000,337.920, 0.000 | 7.50E-01 | 3 |
| 28 | W27E2 | 156.000,337.920, 0.000 | | 196.548,337.920, 0.000 | 6.25E-01 | 3 |
| 29 | | -189.90,530.400, 0.000 | W30E1 | -156.00,530.400, 0.000 | 6.25E-01 | 3 |
| 30 | W29E2 | -156.00,530.400, 0.000 | W31E1 | -120.00,530.400, 0.000 | 7.50E-01 | 3 |

| | | | | | | | | |
|----|-------|------------------|-------|-------|------------------|-------|----------|----|
| 31 | W30E2 | -120.00,530.400, | 0.000 | W32E1 | -72.000,530.400, | 0.000 | 8.75E-01 | 4 |
| 32 | W31E2 | -72.000,530.400, | 0.000 | W33E1 | 72.000,530.400, | 0.000 | 1.00E+00 | 13 |
| 33 | W32E2 | 72.000,530.400, | 0.000 | W34E1 | 120.000,530.400, | 0.000 | 8.75E-01 | 3 |
| 34 | W33E2 | 120.000,530.400, | 0.000 | W35E1 | 156.000,530.400, | 0.000 | 7.50E-01 | 3 |
| 35 | W34E2 | 156.000,530.400, | 0.000 | | 189.900,530.400, | 0.000 | 6.25E-01 | 4 |

----- SOURCES -----

| Source | Wire Seg. | Wire #/Pct Actual | From End 1 (Specified) | Ampl.(V, A) | Phase(Deg.) | Type |
|--------|-----------|-------------------|------------------------|-------------|-------------|------|
| 1 | 7 | 11 / 50.00 | (11 / 50.00) | 1.000 | 0.000 | I |

No loads specified

No transmission lines specified

Ground type is Free Space

EZNEC/4 ver. 2.0

5L48' K6STI YA

07-19-1998

07:44:45

Frequency = 14.175 MHz.

Wire Loss: Aluminum -- Resistivity = 4E-08 ohm-m, Rel. Perm. = 1

----- WIRES -----

| Wire Conn. | --- End 1 (x,y,z : in) | Conn. | --- End 2 (x,y,z : in) | Dia(in) | Segs |
|------------|------------------------------|-------|------------------------|----------|------|
| 1 | -216.50, 0.000, 0.000 | W2E1 | -138.00, 0.000, 0.000 | 5.00E-01 | 10 |
| 2 | W1E2 -138.00, 0.000, 0.000 | W3E1 | -96.000, 0.000, 0.000 | 6.25E-01 | 6 |
| 3 | W2E2 -96.000, 0.000, 0.000 | W4E1 | -48.000, 0.000, 0.000 | 7.50E-01 | 6 |
| 4 | W3E2 -48.000, 0.000, 0.000 | W5E1 | -4.000, 0.000, 0.000 | 8.75E-01 | 5 |
| 5 | W4E2 -4.000, 0.000, 0.000 | W6E1 | 4.000, 0.000, 0.000 | 3.42E+00 | 1 |
| 6 | W5E2 4.000, 0.000, 0.000 | W7E1 | 48.000, 0.000, 0.000 | 8.75E-01 | 5 |
| 7 | W6E2 48.000, 0.000, 0.000 | W8E1 | 96.000, 0.000, 0.000 | 7.50E-01 | 6 |
| 8 | W7E2 96.000, 0.000, 0.000 | W9E1 | 138.000, 0.000, 0.000 | 6.25E-01 | 6 |
| 9 | W8E2 138.000, 0.000, 0.000 | | 216.500, 0.000, 0.000 | 5.00E-01 | 10 |
| 10 | -203.50, 72.000, 0.000 | W11E1 | -138.00, 72.000, 0.000 | 5.00E-01 | 8 |
| 11 | W10E2 -138.00, 72.000, 0.000 | W12E1 | -96.000, 72.000, 0.000 | 6.25E-01 | 6 |
| 12 | W11E2 -96.000, 72.000, 0.000 | W13E1 | -48.000, 72.000, 0.000 | 7.50E-01 | 6 |
| 13 | W12E2 -48.000, 72.000, 0.000 | W14E1 | -4.000, 72.000, 0.000 | 8.75E-01 | 5 |
| 14 | W13E2 -4.000, 72.000, 0.000 | W15E1 | 4.000, 72.000, 0.000 | 3.42E+00 | 1 |
| 15 | W14E2 4.000, 72.000, 0.000 | W16E1 | 48.000, 72.000, 0.000 | 8.75E-01 | 5 |
| 16 | W15E2 48.000, 72.000, 0.000 | W17E1 | 96.000, 72.000, 0.000 | 7.50E-01 | 6 |
| 17 | W16E2 96.000, 72.000, 0.000 | W18E1 | 138.000, 72.000, 0.000 | 6.25E-01 | 6 |

| | | | | | |
|----|-------|------------------------|------------------------------|----------|---|
| 18 | W17E2 | 138.000, 72.000, 0.000 | 203.500, 72.000, 0.000 | 5.00E-01 | 8 |
| 19 | | -201.75,160.000, 0.000 | W20E1 -138.00,160.000, 0.000 | 5.00E-01 | 8 |
| 20 | W19E2 | -138.00,160.000, 0.000 | W21E1 -96.000,160.000, 0.000 | 6.25E-01 | 6 |
| 21 | W20E2 | -96.000,160.000, 0.000 | W22E1 -48.000,160.000, 0.000 | 7.50E-01 | 6 |
| 22 | W21E2 | -48.000,160.000, 0.000 | W23E1 -4.000,160.000, 0.000 | 8.75E-01 | 5 |
| 23 | W22E2 | -4.000,160.000, 0.000 | W24E1 4.000,160.000, 0.000 | 3.42E+00 | 1 |
| 24 | W23E2 | 4.000,160.000, 0.000 | W25E1 48.000,160.000, 0.000 | 8.75E-01 | 5 |
| 25 | W24E2 | 48.000,160.000, 0.000 | W26E1 96.000,160.000, 0.000 | 7.50E-01 | 6 |
| 26 | W25E2 | 96.000,160.000, 0.000 | W27E1 138.000,160.000, 0.000 | 6.25E-01 | 6 |
| 27 | W26E2 | 138.000,160.000, 0.000 | 201.750,160.000, 0.000 | 5.00E-01 | 8 |
| 28 | | -198.88,359.000, 0.000 | W29E1 -138.00,359.000, 0.000 | 5.00E-01 | 8 |
| 29 | W28E2 | -138.00,359.000, 0.000 | W30E1 -96.000,359.000, 0.000 | 6.25E-01 | 5 |
| 30 | W29E2 | -96.000,359.000, 0.000 | W31E1 -48.000,359.000, 0.000 | 7.50E-01 | 6 |
| 31 | W30E2 | -48.000,359.000, 0.000 | W32E1 -4.000,359.000, 0.000 | 8.75E-01 | 6 |
| 32 | W31E2 | -4.000,359.000, 0.000 | W33E1 4.000,359.000, 0.000 | 3.42E+00 | 1 |
| 33 | W32E2 | 4.000,359.000, 0.000 | W34E1 48.000,359.000, 0.000 | 8.75E-01 | 6 |
| 34 | W33E2 | 48.000,359.000, 0.000 | W35E1 96.000,359.000, 0.000 | 7.50E-01 | 6 |
| 35 | W34E2 | 96.000,359.000, 0.000 | W36E1 138.000,359.000, 0.000 | 6.25E-01 | 5 |
| 36 | W35E2 | 138.000,359.000, 0.000 | 198.875,359.000, 0.000 | 5.00E-01 | 8 |
| 37 | | -191.62,570.000, 0.000 | W38E1 -138.00,570.000, 0.000 | 5.00E-01 | 7 |
| 38 | W37E2 | -138.00,570.000, 0.000 | W39E1 -96.000,570.000, 0.000 | 6.25E-01 | 5 |
| 39 | W38E2 | -96.000,570.000, 0.000 | W40E1 -48.000,570.000, 0.000 | 7.50E-01 | 6 |
| 40 | W39E2 | -48.000,570.000, 0.000 | W41E1 -4.000,570.000, 0.000 | 8.75E-01 | 6 |
| 41 | W40E2 | -4.000,570.000, 0.000 | W42E1 4.000,570.000, 0.000 | 3.42E+00 | 1 |
| 42 | W41E2 | 4.000,570.000, 0.000 | W43E1 48.000,570.000, 0.000 | 8.75E-01 | 6 |
| 43 | W42E2 | 48.000,570.000, 0.000 | W44E1 96.000,570.000, 0.000 | 7.50E-01 | 6 |
| 44 | W43E2 | 96.000,570.000, 0.000 | W45E1 138.000,570.000, 0.000 | 6.25E-01 | 5 |
| 45 | W44E2 | 138.000,570.000, 0.000 | 191.625,570.000, 0.000 | 5.00E-01 | 7 |

----- SOURCES -----

| Source | Wire Seg. | Wire #/Pct Actual | From End 1 (Specified) | Ampl.(V, A) | Phase(Deg.) | Type |
|--------|-----------|-------------------|------------------------|-------------|-------------|------|
| 1 | 1 | 14 / 50.00 | (14 / 50.00) | 1.000 | 0.000 | V |

No loads specified

No transmission lines specified

Ground type is Free Space

EZNEC/4 ver. 2.0

5L48' W3LPL WWW

07-19-1998

07:45:37

Frequency = 14.175 MHz.

Wire Loss: Aluminum -- Resistivity = 4E-08 ohm-m, Rel. Perm. = 1

----- WIRES -----

| Wire Conn. | --- End 1 (x,y,z : in) | Conn. | --- End 2 (x,y,z : in) | Dia(in) | Segs |
|------------|------------------------------|-------|------------------------|----------|------|
| 1 | -217.00, 0.000, 0.000 | W2E1 | -150.00, 0.000, 0.000 | 7.50E-01 | 8 |
| 2 | W1E2 -150.00, 0.000, 0.000 | W3E1 | -117.00, 0.000, 0.000 | 8.75E-01 | 4 |
| 3 | W2E2 -117.00, 0.000, 0.000 | W4E1 | -84.000, 0.000, 0.000 | 1.00E+00 | 4 |
| 4 | W3E2 -84.000, 0.000, 0.000 | W5E1 | -33.750, 0.000, 0.000 | 1.12E+00 | 6 |
| 5 | W4E2 -33.750, 0.000, 0.000 | W6E1 | 33.750, 0.000, 0.000 | 1.25E+00 | 9 |
| 6 | W5E2 33.750, 0.000, 0.000 | W7E1 | 84.000, 0.000, 0.000 | 1.12E+00 | 6 |
| 7 | W6E2 84.000, 0.000, 0.000 | W8E1 | 117.000, 0.000, 0.000 | 1.00E+00 | 4 |
| 8 | W7E2 117.000, 0.000, 0.000 | W9E1 | 150.000, 0.000, 0.000 | 8.75E-01 | 4 |
| 9 | W8E2 150.000, 0.000, 0.000 | | 217.000, 0.000, 0.000 | 7.50E-01 | 8 |
| 10 | -212.00, 86.000, 0.000 | W11E1 | -150.00, 86.000, 0.000 | 7.50E-01 | 8 |
| 11 | W10E2 -150.00, 86.000, 0.000 | W12E1 | -117.00, 86.000, 0.000 | 8.75E-01 | 4 |
| 12 | W11E2 -117.00, 86.000, 0.000 | W13E1 | -84.000, 86.000, 0.000 | 1.00E+00 | 4 |
| 13 | W12E2 -84.000, 86.000, 0.000 | W14E1 | -33.750, 86.000, 0.000 | 1.12E+00 | 6 |
| 14 | W13E2 -33.750, 86.000, 0.000 | W15E1 | 33.750, 86.000, 0.000 | 1.25E+00 | 9 |
| 15 | W14E2 33.750, 86.000, 0.000 | W16E1 | 84.000, 86.000, 0.000 | 1.12E+00 | 6 |
| 16 | W15E2 84.000, 86.000, 0.000 | W17E1 | 117.000, 86.000, 0.000 | 1.00E+00 | 4 |
| 17 | W16E2 117.000, 86.000, 0.000 | W18E1 | 150.000, 86.000, 0.000 | 8.75E-01 | 4 |
| 18 | W17E2 150.000, 86.000, 0.000 | | 212.000, 86.000, 0.000 | 7.50E-01 | 8 |
| 19 | -199.38,171.000, 0.000 | W20E1 | -135.88,171.000, 0.000 | 7.50E-01 | 8 |
| 20 | W19E2 -135.88,171.000, 0.000 | W21E1 | -102.88,171.000, 0.000 | 8.75E-01 | 4 |
| 21 | W20E2 -102.88,171.000, 0.000 | W22E1 | -69.875,171.000, 0.000 | 1.00E+00 | 4 |
| 22 | W21E2 -69.875,171.000, 0.000 | W23E1 | -22.000,171.000, 0.000 | 1.12E+00 | 6 |
| 23 | W22E2 -22.000,171.000, 0.000 | W24E1 | 22.000,171.000, 0.000 | 1.25E+00 | 5 |
| 24 | W23E2 22.000,171.000, 0.000 | W25E1 | 69.875,171.000, 0.000 | 1.12E+00 | 6 |
| 25 | W24E2 69.875,171.000, 0.000 | W26E1 | 102.875,171.000, 0.000 | 1.00E+00 | 4 |
| 26 | W25E2 102.875,171.000, 0.000 | W27E1 | 135.875,171.000, 0.000 | 8.75E-01 | 4 |
| 27 | W26E2 135.875,171.000, 0.000 | | 199.380,171.000, 0.000 | 7.50E-01 | 8 |
| 28 | -196.25,349.000, 0.000 | W29E1 | -119.25,349.000, 0.000 | 7.50E-01 | 10 |
| 29 | W28E2 -119.25,349.000, 0.000 | W30E1 | -86.250,349.000, 0.000 | 8.75E-01 | 4 |
| 30 | W29E2 -86.250,349.000, 0.000 | W31E1 | -53.250,349.000, 0.000 | 1.00E+00 | 4 |
| 31 | W30E2 -53.250,349.000, 0.000 | W32E1 | -22.000,349.000, 0.000 | 1.12E+00 | 4 |
| 32 | W31E2 -22.000,349.000, 0.000 | W33E1 | 22.000,349.000, 0.000 | 1.25E+00 | 5 |
| 33 | W32E2 22.000,349.000, 0.000 | W34E1 | 53.250,349.000, 0.000 | 1.12E+00 | 4 |
| 34 | W33E2 53.250,349.000, 0.000 | W35E1 | 86.250,349.000, 0.000 | 1.00E+00 | 4 |
| 35 | W34E2 86.250,349.000, 0.000 | W36E1 | 119.250,349.000, 0.000 | 8.75E-01 | 4 |
| 36 | W35E2 119.250,349.000, 0.000 | | 196.250,349.000, 0.000 | 7.50E-01 | 10 |
| 37 | -183.75,570.000, 0.000 | W38E1 | -131.75,570.000, 0.000 | 7.50E-01 | 7 |
| 38 | W37E2 -131.75,570.000, 0.000 | W39E1 | -98.750,570.000, 0.000 | 8.75E-01 | 4 |
| 39 | W38E2 -98.750,570.000, 0.000 | W40E1 | -65.750,570.000, 0.000 | 1.00E+00 | 4 |
| 40 | W39E2 -65.750,570.000, 0.000 | W41E1 | -22.000,570.000, 0.000 | 1.12E+00 | 5 |
| 41 | W40E2 -22.000,570.000, 0.000 | W42E1 | 22.000,570.000, 0.000 | 1.25E+00 | 5 |
| 42 | W41E2 22.000,570.000, 0.000 | W43E1 | 65.750,570.000, 0.000 | 1.12E+00 | 5 |
| 43 | W42E2 65.750,570.000, 0.000 | W44E1 | 98.750,570.000, 0.000 | 1.00E+00 | 4 |

| | | | | | | | | |
|----|-------|------------------|-------|-------|------------------|-------|----------|---|
| 44 | W43E2 | 98.750,570.000, | 0.000 | W45E1 | 131.750,570.000, | 0.000 | 8.75E-01 | 4 |
| 45 | W44E2 | 131.750,570.000, | 0.000 | | 183.750,570.000, | 0.000 | 7.50E-01 | 7 |

----- SOURCES -----

| Source | Wire Seg. | Wire #/Pct Actual | From End 1 (Specified) | Ampl.(V, A) | Phase(Deg.) | Type |
|--------|-----------|-------------------|------------------------|-------------|-------------|------|
| 1 | 5 | 14 / 50.00 | (14 / 50.00) | 1.000 | 0.000 | V |

No loads specified

No transmission lines specified

Ground type is Free Space

EZNEC/4 ver. 2.0

K4SB 5-element, 55' boom

07-19-1998

07:46:17

Frequency = 14.175 MHz.

Wire Loss: Aluminum -- Resistivity = 4E-08 ohm-m, Rel. Perm. = 1

----- WIRES -----

| Wire Conn. | --- End 1 (x,y,z : in) | Conn. | --- End 2 (x,y,z : in) | Dia(in) | Segs |
|------------|------------------------------|-------|------------------------|----------|------|
| 1 | -217.00, 0.000, 0.000 | W2E1 | -152.00, 0.000, 0.000 | 5.00E-01 | 7 |
| 2 | W1E2 -152.00, 0.000, 0.000 | W3E1 | -116.00, 0.000, 0.000 | 6.25E-01 | 4 |
| 3 | W2E2 -116.00, 0.000, 0.000 | W4E1 | -72.000, 0.000, 0.000 | 7.50E-01 | 4 |
| 4 | W3E2 -72.000, 0.000, 0.000 | W5E1 | -48.000, 0.000, 0.000 | 8.75E-01 | 2 |
| 5 | W4E2 -48.000, 0.000, 0.000 | W6E1 | 48.000, 0.000, 0.000 | 1.00E+00 | 9 |
| 6 | W5E2 48.000, 0.000, 0.000 | W7E1 | 72.000, 0.000, 0.000 | 8.75E-01 | 2 |
| 7 | W6E2 72.000, 0.000, 0.000 | W8E1 | 116.000, 0.000, 0.000 | 7.50E-01 | 4 |
| 8 | W7E2 116.000, 0.000, 0.000 | W9E1 | 152.000, 0.000, 0.000 | 6.25E-01 | 4 |
| 9 | W8E2 152.000, 0.000, 0.000 | | 217.000, 0.000, 0.000 | 5.00E-01 | 7 |
| 10 | -207.50,182.504, 0.000 | W11E1 | -152.00,182.504, 0.000 | 5.00E-01 | 6 |
| 11 | W10E2 -152.00,182.504, 0.000 | W12E1 | -116.00,182.504, 0.000 | 6.25E-01 | 4 |
| 12 | W11E2 -116.00,182.504, 0.000 | W13E1 | -72.000,182.504, 0.000 | 7.50E-01 | 4 |
| 13 | W12E2 -72.000,182.504, 0.000 | W14E1 | -48.000,182.504, 0.000 | 8.75E-01 | 2 |
| 14 | W13E2 -48.000,182.504, 0.000 | W15E1 | 48.000,182.504, 0.000 | 1.00E+00 | 9 |
| 15 | W14E2 48.000,182.504, 0.000 | W16E1 | 72.000,182.504, 0.000 | 8.75E-01 | 2 |
| 16 | W15E2 72.000,182.504, 0.000 | W17E1 | 116.000,182.504, 0.000 | 7.50E-01 | 4 |
| 17 | W16E2 116.000,182.504, 0.000 | W18E1 | 152.000,182.504, 0.000 | 6.25E-01 | 4 |
| 18 | W17E2 152.000,182.504, 0.000 | | 207.500,182.504, 0.000 | 5.00E-01 | 6 |
| 19 | -195.53,269.544, 0.000 | W20E1 | -152.00,269.544, 0.000 | 5.00E-01 | 4 |
| 20 | W19E2 -152.00,269.544, 0.000 | W21E1 | -116.00,269.544, 0.000 | 6.25E-01 | 4 |

| | | | | | | | | |
|----|-------|------------------|-------|-------|------------------|-------|----------|---|
| 21 | W20E2 | -116.00,269.544, | 0.000 | W22E1 | -72.000,269.544, | 0.000 | 7.50E-01 | 4 |
| 22 | W21E2 | -72.000,269.544, | 0.000 | W23E1 | -48.000,269.544, | 0.000 | 8.75E-01 | 2 |
| 23 | W22E2 | -48.000,269.544, | 0.000 | W24E1 | 48.000,269.544, | 0.000 | 1.00E+00 | 9 |
| 24 | W23E2 | 48.000,269.544, | 0.000 | W25E1 | 72.000,269.544, | 0.000 | 8.75E-01 | 2 |
| 25 | W24E2 | 72.000,269.544, | 0.000 | W26E1 | 116.000,269.544, | 0.000 | 7.50E-01 | 4 |
| 26 | W25E2 | 116.000,269.544, | 0.000 | W27E1 | 152.000,269.544, | 0.000 | 6.25E-01 | 4 |
| 27 | W26E2 | 152.000,269.544, | 0.000 | | 195.530,269.544, | 0.000 | 5.00E-01 | 4 |
| 28 | | -192.48,448.494, | 0.000 | W29E1 | -152.00,448.494, | 0.000 | 5.00E-01 | 4 |
| 29 | W28E2 | -152.00,448.494, | 0.000 | W30E1 | -116.00,448.494, | 0.000 | 6.25E-01 | 4 |
| 30 | W29E2 | -116.00,448.494, | 0.000 | W31E1 | -72.000,448.494, | 0.000 | 7.50E-01 | 4 |
| 31 | W30E2 | -72.000,448.494, | 0.000 | W32E1 | -48.000,448.494, | 0.000 | 8.75E-01 | 2 |
| 32 | W31E2 | -48.000,448.494, | 0.000 | W33E1 | 48.000,448.494, | 0.000 | 1.00E+00 | 9 |
| 33 | W32E2 | 48.000,448.494, | 0.000 | W34E1 | 72.000,448.494, | 0.000 | 8.75E-01 | 2 |
| 34 | W33E2 | 72.000,448.494, | 0.000 | W35E1 | 116.000,448.494, | 0.000 | 7.50E-01 | 4 |
| 35 | W34E2 | 116.000,448.494, | 0.000 | W36E1 | 152.000,448.494, | 0.000 | 6.25E-01 | 4 |
| 36 | W35E2 | 152.000,448.494, | 0.000 | | 192.480,448.494, | 0.000 | 5.00E-01 | 4 |
| 37 | | -189.42,656.474, | 0.000 | W38E1 | -152.00,656.474, | 0.000 | 5.00E-01 | 4 |
| 38 | W37E2 | -152.00,656.474, | 0.000 | W39E1 | -116.00,656.474, | 0.000 | 6.25E-01 | 4 |
| 39 | W38E2 | -116.00,656.474, | 0.000 | W40E1 | -72.000,656.474, | 0.000 | 7.50E-01 | 4 |
| 40 | W39E2 | -72.000,656.474, | 0.000 | W41E1 | -48.000,656.474, | 0.000 | 8.75E-01 | 2 |
| 41 | W40E2 | -48.000,656.474, | 0.000 | W42E1 | 48.000,656.474, | 0.000 | 1.00E+00 | 9 |
| 42 | W41E2 | 48.000,656.474, | 0.000 | W43E1 | 72.000,656.474, | 0.000 | 8.75E-01 | 2 |
| 43 | W42E2 | 72.000,656.474, | 0.000 | W44E1 | 116.000,656.474, | 0.000 | 7.50E-01 | 4 |
| 44 | W43E2 | 116.000,656.474, | 0.000 | W45E1 | 152.000,656.474, | 0.000 | 6.25E-01 | 4 |
| 45 | W44E2 | 152.000,656.474, | 0.000 | | 189.420,656.474, | 0.000 | 5.00E-01 | 4 |

----- SOURCES -----

| Source | Wire Seg. | Wire #/Pct Actual | From End 1 (Specified) | Ampl.(V, A) | Phase(Deg.) | Type |
|--------|-----------|-------------------|------------------------|-------------|-------------|------|
| 1 | 5 | 14 / 50.00 | (14 / 50.00) | 1.000 | 0.000 | V |

No loads specified

No transmission lines specified

Ground type is Free Space

EZNEC/4 ver. 2.0

NW3Z 6 el, 48' boom WWW

07-19-1998

07:47:18

Frequency = 14.175 MHz.

Wire Loss: Aluminum -- Resistivity = 4E-08 ohm-m, Rel. Perm. = 1

----- WIRES -----

| Wire | Conn. | --- | End 1 (x,y,z : in) | Conn. | --- | End 2 (x,y,z : in) | Dia(in) | Segs |
|------|-------|-----|-------------------------|-------|-----|-------------------------|----------|------|
| 1 | | | -217.73, 0.000, 0.000 | W2E1 | | -152.00, 0.000, 0.000 | 5.00E-01 | 7 |
| 2 | W1E2 | | -152.00, 0.000, 0.000 | W3E1 | | -116.00, 0.000, 0.000 | 6.25E-01 | 4 |
| 3 | W2E2 | | -116.00, 0.000, 0.000 | W4E1 | | -72.000, 0.000, 0.000 | 7.50E-01 | 4 |
| 4 | W3E2 | | -72.000, 0.000, 0.000 | W5E1 | | -48.000, 0.000, 0.000 | 8.75E-01 | 2 |
| 5 | W4E2 | | -48.000, 0.000, 0.000 | W6E1 | | 48.000, 0.000, 0.000 | 1.00E+00 | 9 |
| 6 | W5E2 | | 48.000, 0.000, 0.000 | W7E1 | | 72.000, 0.000, 0.000 | 8.75E-01 | 2 |
| 7 | W6E2 | | 72.000, 0.000, 0.000 | W8E1 | | 116.000, 0.000, 0.000 | 7.50E-01 | 4 |
| 8 | W7E2 | | 116.000, 0.000, 0.000 | W9E1 | | 152.000, 0.000, 0.000 | 6.25E-01 | 4 |
| 9 | W8E2 | | 152.000, 0.000, 0.000 | | | 217.730, 0.000, 0.000 | 5.00E-01 | 7 |
| 10 | | | -210.70, 90.000, 0.000 | W11E1 | | -152.00, 90.000, 0.000 | 5.00E-01 | 6 |
| 11 | W10E2 | | -152.00, 90.000, 0.000 | W12E1 | | -116.00, 90.000, 0.000 | 6.25E-01 | 4 |
| 12 | W11E2 | | -116.00, 90.000, 0.000 | W13E1 | | -72.000, 90.000, 0.000 | 7.50E-01 | 4 |
| 13 | W12E2 | | -72.000, 90.000, 0.000 | W14E1 | | -48.000, 90.000, 0.000 | 8.75E-01 | 2 |
| 14 | W13E2 | | -48.000, 90.000, 0.000 | W15E1 | | 48.000, 90.000, 0.000 | 1.00E+00 | 9 |
| 15 | W14E2 | | 48.000, 90.000, 0.000 | W16E1 | | 72.000, 90.000, 0.000 | 8.75E-01 | 2 |
| 16 | W15E2 | | 72.000, 90.000, 0.000 | W17E1 | | 116.000, 90.000, 0.000 | 7.50E-01 | 4 |
| 17 | W16E2 | | 116.000, 90.000, 0.000 | W18E1 | | 152.000, 90.000, 0.000 | 6.25E-01 | 4 |
| 18 | W17E2 | | 152.000, 90.000, 0.000 | | | 210.700, 90.000, 0.000 | 5.00E-01 | 6 |
| 19 | | | -200.80, 139.520, 0.000 | W20E1 | | -152.00, 139.520, 0.000 | 5.00E-01 | 5 |
| 20 | W19E2 | | -152.00, 139.520, 0.000 | W21E1 | | -116.00, 139.520, 0.000 | 6.25E-01 | 4 |
| 21 | W20E2 | | -116.00, 139.520, 0.000 | W22E1 | | -72.000, 139.520, 0.000 | 7.50E-01 | 4 |
| 22 | W21E2 | | -72.000, 139.520, 0.000 | W23E1 | | -48.000, 139.520, 0.000 | 8.75E-01 | 2 |
| 23 | W22E2 | | -48.000, 139.520, 0.000 | W24E1 | | 48.000, 139.520, 0.000 | 1.00E+00 | 9 |
| 24 | W23E2 | | 48.000, 139.520, 0.000 | W25E1 | | 72.000, 139.520, 0.000 | 8.75E-01 | 2 |
| 25 | W24E2 | | 72.000, 139.520, 0.000 | W26E1 | | 116.000, 139.520, 0.000 | 7.50E-01 | 4 |
| 26 | W25E2 | | 116.000, 139.520, 0.000 | W27E1 | | 152.000, 139.520, 0.000 | 6.25E-01 | 4 |
| 27 | W26E2 | | 152.000, 139.520, 0.000 | | | 200.800, 139.520, 0.000 | 5.00E-01 | 5 |
| 28 | | | -194.62, 266.700, 0.000 | W29E1 | | -152.00, 266.700, 0.000 | 5.00E-01 | 4 |
| 29 | W28E2 | | -152.00, 266.700, 0.000 | W30E1 | | -116.00, 266.700, 0.000 | 6.25E-01 | 4 |
| 30 | W29E2 | | -116.00, 266.700, 0.000 | W31E1 | | -72.000, 266.700, 0.000 | 7.50E-01 | 4 |
| 31 | W30E2 | | -72.000, 266.700, 0.000 | W32E1 | | -48.000, 266.700, 0.000 | 8.75E-01 | 2 |
| 32 | W31E2 | | -48.000, 266.700, 0.000 | W33E1 | | 48.000, 266.700, 0.000 | 1.00E+00 | 9 |
| 33 | W32E2 | | 48.000, 266.700, 0.000 | W34E1 | | 72.000, 266.700, 0.000 | 8.75E-01 | 2 |
| 34 | W33E2 | | 72.000, 266.700, 0.000 | W35E1 | | 116.000, 266.700, 0.000 | 7.50E-01 | 4 |
| 35 | W34E2 | | 116.000, 266.700, 0.000 | W36E1 | | 152.000, 266.700, 0.000 | 6.25E-01 | 4 |
| 36 | W35E2 | | 152.000, 266.700, 0.000 | | | 194.620, 266.700, 0.000 | 5.00E-01 | 4 |
| 37 | | | -194.63, 388.440, 0.000 | W38E1 | | -152.00, 388.440, 0.000 | 5.00E-01 | 4 |
| 38 | W37E2 | | -152.00, 388.440, 0.000 | W39E1 | | -116.00, 388.440, 0.000 | 6.25E-01 | 4 |
| 39 | W38E2 | | -116.00, 388.440, 0.000 | W40E1 | | -72.000, 388.440, 0.000 | 7.50E-01 | 4 |
| 40 | W39E2 | | -72.000, 388.440, 0.000 | W41E1 | | -48.000, 388.440, 0.000 | 8.75E-01 | 2 |
| 41 | W40E2 | | -48.000, 388.440, 0.000 | W42E1 | | 48.000, 388.440, 0.000 | 1.00E+00 | 9 |
| 42 | W41E2 | | 48.000, 388.440, 0.000 | W43E1 | | 72.000, 388.440, 0.000 | 8.75E-01 | 2 |
| 43 | W42E2 | | 72.000, 388.440, 0.000 | W44E1 | | 116.000, 388.440, 0.000 | 7.50E-01 | 4 |
| 44 | W43E2 | | 116.000, 388.440, 0.000 | W45E1 | | 152.000, 388.440, 0.000 | 6.25E-01 | 4 |
| 45 | W44E2 | | 152.000, 388.440, 0.000 | | | 194.630, 388.440, 0.000 | 5.00E-01 | 4 |
| 46 | | | -187.39, 570.000, 0.000 | W47E1 | | -152.00, 570.000, 0.000 | 5.00E-01 | 4 |
| 47 | W46E2 | | -152.00, 570.000, 0.000 | W48E1 | | -116.00, 570.000, 0.000 | 6.25E-01 | 4 |

| | | | | | | | | |
|----|-------|------------------|-------|-------|------------------|-------|----------|---|
| 48 | W47E2 | -116.00,570.000, | 0.000 | W49E1 | -72.000,570.000, | 0.000 | 7.50E-01 | 4 |
| 49 | W48E2 | -72.000,570.000, | 0.000 | W50E1 | -48.000,570.000, | 0.000 | 8.75E-01 | 2 |
| 50 | W49E2 | -48.000,570.000, | 0.000 | W51E1 | 48.000,570.000, | 0.000 | 1.00E+00 | 9 |
| 51 | W50E2 | 48.000,570.000, | 0.000 | W52E1 | 72.000,570.000, | 0.000 | 8.75E-01 | 2 |
| 52 | W51E2 | 72.000,570.000, | 0.000 | W53E1 | 116.000,570.000, | 0.000 | 7.50E-01 | 4 |
| 53 | W52E2 | 116.000,570.000, | 0.000 | W54E1 | 152.000,570.000, | 0.000 | 6.25E-01 | 4 |
| 54 | W53E2 | 152.000,570.000, | 0.000 | | 187.390,570.000, | 0.000 | 5.00E-01 | 4 |

----- SOURCES -----

| Source | Wire Seg. | Wire #/Pct Actual | From End 1 (Specified) | Ampl.(V, A) | Phase(Deg.) | Type |
|--------|-----------|-------------------|------------------------|-------------|-------------|------|
| 1 | 5 | 14 / 50.00 | (14 / 50.00) | 1.000 | 0.000 | V |

No loads specified

No transmission lines specified

Ground type is Free Space

EZNEC/4 ver. 2.0

Hy-Gain 205-XLB, 48' Boom (WB0DGF) 07-19-1998 07:55:56

Frequency = 14.175 MHz.

Wire Loss: Aluminum -- Resistivity = 4E-08 ohm-m, Rel. Perm. = 1

----- WIRES -----

| Wire Conn. | --- End 1 (x,y,z : in) | Conn. | --- End 2 (x,y,z : in) | Dia(in) | Segs |
|------------|------------------------------|-------|------------------------|----------|------|
| 1 | -286.00,-223.75, 0.000 | W2E1 | -286.00,-166.00, 0.000 | 4.38E-01 | 7 |
| 2 | W1E2 -286.00,-166.00, 0.000 | W3E1 | -286.00,-142.00, 0.000 | 6.25E-01 | 3 |
| 3 | W2E2 -286.00,-142.00, 0.000 | W4E1 | -286.00,-91.500, 0.000 | 8.75E-01 | 6 |
| 4 | W3E2 -286.00,-91.500, 0.000 | W5E1 | -286.00,-45.500, 0.000 | 1.12E+00 | 6 |
| 5 | W4E2 -286.00,-45.500, 0.000 | W6E1 | -286.00, -3.625, 0.000 | 1.25E+00 | 5 |
| 6 | W5E2 -286.00, -3.625, 0.000 | W7E1 | -286.00, 3.625, 0.000 | 4.00E+00 | 1 |
| 7 | W6E2 -286.00, 3.625, 0.000 | W8E1 | -286.00, 45.500, 0.000 | 1.25E+00 | 5 |
| 8 | W7E2 -286.00, 45.500, 0.000 | W9E1 | -286.00, 91.500, 0.000 | 1.12E+00 | 6 |
| 9 | W8E2 -286.00, 91.500, 0.000 | W10E1 | -286.00,142.000, 0.000 | 8.75E-01 | 6 |
| 10 | W9E2 -286.00,142.000, 0.000 | W11E1 | -286.00,166.000, 0.000 | 6.25E-01 | 3 |
| 11 | W10E2 -286.00,166.000, 0.000 | | -286.00,223.750, 0.000 | 4.38E-01 | 7 |
| 12 | -170.00,-209.50, 0.000 | W13E1 | -170.00,-156.50, 0.000 | 4.38E-01 | 7 |
| 13 | W12E2 -170.00,-156.50, 0.000 | W14E1 | -170.00,-132.50, 0.000 | 6.25E-01 | 3 |
| 14 | W13E2 -170.00,-132.50, 0.000 | W15E1 | -170.00,-82.000, 0.000 | 8.75E-01 | 6 |
| 15 | W14E2 -170.00,-82.000, 0.000 | W16E1 | -170.00,-36.000, 0.000 | 1.12E+00 | 6 |

| | | | | | | | | |
|----|-------|-------------------|-------|-------|-------------------|-------|----------|---|
| 16 | W15E2 | -170.00, -36.000, | 0.000 | W17E1 | -170.00, -10.000, | 0.000 | 1.25E+00 | 3 |
| 17 | W16E2 | -170.00, -10.000, | 0.000 | W18E1 | -170.00, 10.000, | 0.000 | 1.25E+00 | 3 |
| 18 | W17E2 | -170.00, 10.000, | 0.000 | W19E1 | -170.00, 36.000, | 0.000 | 1.25E+00 | 3 |
| 19 | W18E2 | -170.00, 36.000, | 0.000 | W20E1 | -170.00, 82.000, | 0.000 | 1.12E+00 | 6 |
| 20 | W19E2 | -170.00, 82.000, | 0.000 | W21E1 | -170.00, 132.500, | 0.000 | 8.75E-01 | 6 |
| 21 | W20E2 | -170.00, 132.500, | 0.000 | W22E1 | -170.00, 156.500, | 0.000 | 6.25E-01 | 3 |
| 22 | W21E2 | -170.00, 156.500, | 0.000 | | -170.00, 209.500, | 0.000 | 4.38E-01 | 7 |
| 23 | | -80.000, -206.25, | 0.000 | W24E1 | -80.000, -156.50, | 0.000 | 4.38E-01 | 6 |
| 24 | W23E2 | -80.000, -156.50, | 0.000 | W25E1 | -80.000, -132.50, | 0.000 | 6.25E-01 | 3 |
| 25 | W24E2 | -80.000, -132.50, | 0.000 | W26E1 | -80.000, -82.000, | 0.000 | 8.75E-01 | 6 |
| 26 | W25E2 | -80.000, -82.000, | 0.000 | W27E1 | -80.000, -36.000, | 0.000 | 1.12E+00 | 6 |
| 27 | W26E2 | -80.000, -36.000, | 0.000 | W28E1 | -80.000, -3.625, | 0.000 | 1.25E+00 | 4 |
| 28 | W27E2 | -80.000, -3.625, | 0.000 | W29E1 | -80.000, 3.625, | 0.000 | 4.00E+00 | 1 |
| 29 | W28E2 | -80.000, 3.625, | 0.000 | W30E1 | -80.000, 36.000, | 0.000 | 1.25E+00 | 4 |
| 30 | W29E2 | -80.000, 36.000, | 0.000 | W31E1 | -80.000, 82.000, | 0.000 | 1.12E+00 | 6 |
| 31 | W30E2 | -80.000, 82.000, | 0.000 | W32E1 | -80.000, 132.500, | 0.000 | 8.75E-01 | 6 |
| 32 | W31E2 | -80.000, 132.500, | 0.000 | W33E1 | -80.000, 156.500, | 0.000 | 6.25E-01 | 3 |
| 33 | W32E2 | -80.000, 156.500, | 0.000 | | -80.000, 206.250, | 0.000 | 4.38E-01 | 6 |
| 34 | | 86.000, -203.25, | 0.000 | W35E1 | 86.000, -156.50, | 0.000 | 4.38E-01 | 6 |
| 35 | W34E2 | 86.000, -156.50, | 0.000 | W36E1 | 86.000, -132.50, | 0.000 | 6.25E-01 | 3 |
| 36 | W35E2 | 86.000, -132.50, | 0.000 | W37E1 | 86.000, -82.000, | 0.000 | 8.75E-01 | 6 |
| 37 | W36E2 | 86.000, -82.000, | 0.000 | W38E1 | 86.000, -36.000, | 0.000 | 1.12E+00 | 6 |
| 38 | W37E2 | 86.000, -36.000, | 0.000 | W39E1 | 86.000, -3.625, | 0.000 | 1.25E+00 | 4 |
| 39 | W38E2 | 86.000, -3.625, | 0.000 | W40E1 | 86.000, 3.625, | 0.000 | 4.00E+00 | 1 |
| 40 | W39E2 | 86.000, 3.625, | 0.000 | W41E1 | 86.000, 36.000, | 0.000 | 1.25E+00 | 4 |
| 41 | W40E2 | 86.000, 36.000, | 0.000 | W42E1 | 86.000, 82.000, | 0.000 | 1.12E+00 | 6 |
| 42 | W41E2 | 86.000, 82.000, | 0.000 | W43E1 | 86.000, 132.500, | 0.000 | 8.75E-01 | 6 |
| 43 | W42E2 | 86.000, 132.500, | 0.000 | W44E1 | 86.000, 156.500, | 0.000 | 6.25E-01 | 3 |
| 44 | W43E2 | 86.000, 156.500, | 0.000 | | 86.000, 203.250, | 0.000 | 4.38E-01 | 6 |
| 45 | | 286.000, -193.12, | 0.000 | W46E1 | 286.000, -138.25, | 0.000 | 4.38E-01 | 7 |
| 46 | W45E2 | 286.000, -138.25, | 0.000 | W47E1 | 286.000, -114.25, | 0.000 | 6.25E-01 | 3 |
| 47 | W46E2 | 286.000, -114.25, | 0.000 | W48E1 | 286.000, -63.750, | 0.000 | 8.75E-01 | 6 |
| 48 | W47E2 | 286.000, -63.750, | 0.000 | W49E1 | 286.000, -17.750, | 0.000 | 1.12E+00 | 6 |
| 49 | W48E2 | 286.000, -17.750, | 0.000 | W50E1 | 286.000, -3.625, | 0.000 | 1.25E+00 | 2 |
| 50 | W49E2 | 286.000, -3.625, | 0.000 | W51E1 | 286.000, 3.625, | 0.000 | 4.00E+00 | 1 |
| 51 | W50E2 | 286.000, 3.625, | 0.000 | W52E1 | 286.000, 17.750, | 0.000 | 1.25E+00 | 2 |
| 52 | W51E2 | 286.000, 17.750, | 0.000 | W53E1 | 286.000, 63.750, | 0.000 | 1.12E+00 | 6 |
| 53 | W52E2 | 286.000, 63.750, | 0.000 | W54E1 | 286.000, 114.250, | 0.000 | 8.75E-01 | 6 |
| 54 | W53E2 | 286.000, 114.250, | 0.000 | W55E1 | 286.000, 138.250, | 0.000 | 6.25E-01 | 3 |
| 55 | W54E2 | 286.000, 138.250, | 0.000 | | 286.000, 193.125, | 0.000 | 4.38E-01 | 7 |

----- SOURCES -----

| Source | Wire Seg. | Wire #/Pct Actual | From End 1 (Specified) | Ampl.(V, A) | Phase(Deg.) | Type |
|--------|-----------|-------------------|------------------------|-------------|-------------|------|
| 1 | 2 | 17 / 50.00 | (17 / 50.00) | 0.707 | 0.000 | V |

No loads specified

No transmission lines specified

Ground type is Free Space

Any transcription errors in the above models are strictly my own fault, and I shall gladly correct any found.

Updated 7-20-98. © L. B. Cebik, W4RNL. Data may be used for personal purposes, but may not be reproduced for publication in print or any other medium without permission of the author.



[Go to Amateur Radio Page](#)

Projects and Info Center

Check out [The Optimized Wideband Antenna \(OWA\) Yagi](#) article by my very good friends Jim Breakall (WA3FET) and Nathan Miller (NW3Z). Jim and Nathan have also designed the [SKYHAWK](#). A State-of-the-Art Trapless Tribander from Bencher/Butternut.

NEW!

[An Upgraded version of the OWA article and pics of the WP3R Contest site owned by WA3FET](#)

- [OWA](#)
- [UPGRADED OWA ARTICLE](#)
- [SKYHAWK](#)
- [RACZPR](#) (Radio Astronomy Coordination Zone in Puerto Rico [Spanish]).

[Back to KP4AO HOME page.](#)



---->Please send any comments or suggestions to Angel M. Vazquez - WP3R

angel@naic.edu.

Last updated Sunday, February 15, 1998

[\[Refresh this Menu\]](#)

[TEARA]

US<-Find Calls->DX |



Custom
Motorcycle
Accessories |

- [Home](#)
- [Newsletters](#)
- [Club Bulletins](#)
- [Calendar](#)
- [Club Stuff](#)
- [The Repeaters](#)
- [FCC/License Info](#)
- [TEARA's Links](#)
- [APRS WX Info](#)
- [\[Miscellaneous \]](#)
- [DXing Goodies](#)
- [Activities in NC](#)
- [Shops/Dealers](#)
- [Ham News](#)
- [Packet Radio](#)
- [ATV!](#)
- [Knowledge Quest](#)
- [Ham Classifieds](#)
- [Software](#)

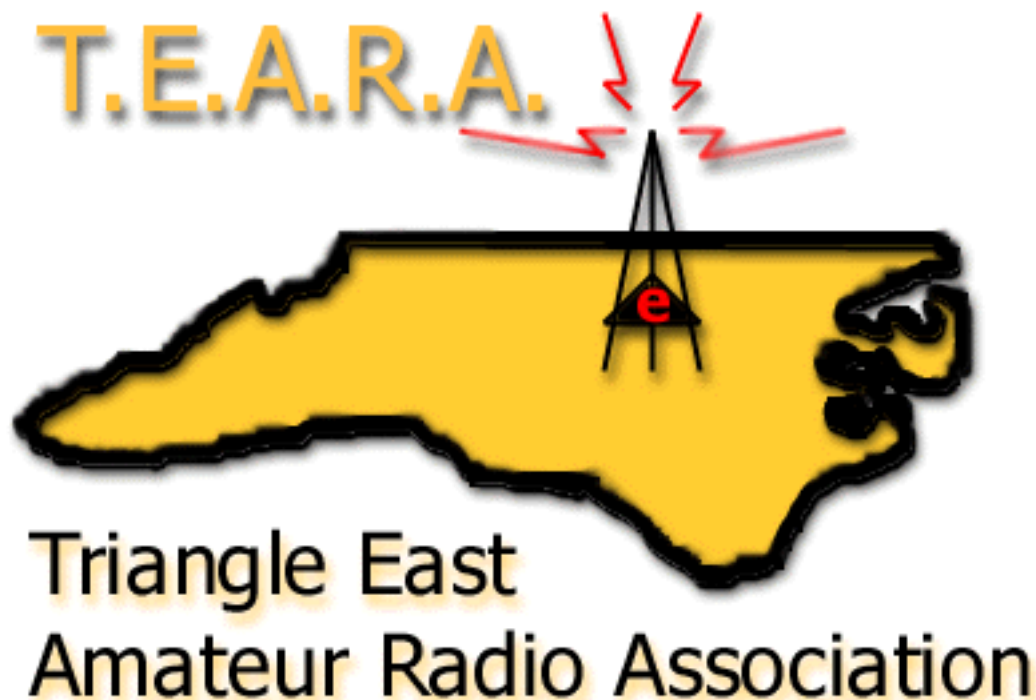

TEARA - The Triangle East ARA

3509 Rolesville Road; Wendell, NC 27591-9135

WAIT!! If you came to this page directly from a search engine or link, and don't see a menu to the left and top of this page, you're missing out on hundreds of pages of amateur related info on our server. [CLICK HERE](#), or click the large NC State Logo at the top, to move to the top of our site (which automatically loads this page). From there, you can select hundreds of pages of information on our server, complete with all of our site navigation tools. Enjoy your visit with [TEARA!](#)

The TEARA Email Reflector

An Email Group for Triangle area Amateurs!

 The TEARA email list is primarily for TEARA (Triangle East Amateur Radio Association) members, and those interested in membership in central NC. It is specific to this local amateur radio club for the purpose of distributing club bulletins and promoting communication within the club membership.

 The list can be subscribed to as a normal list, or as a digest. Here is the subscription info:

- To subscribe to the list through email, send an email to:
teara-subscribe@yahoogroups.com
- To unsubscribe to the list through email, send an email to:
teara-unsubscribe@yahoogroups.com
- To switch your subscription to normal, send an email to:
teara-normal@yahoogroups.com
- To switch your subscription to digest, send an email to:
teara-digest@yahoogroups.com

 Once you're subscribed, send your messages to: teara@onelist.com and everyone who is subscribed will see them.

[\[Digest Version\]](#)

 Now, having said that, I wonder how many of you are aware that this list is available in "DIGEST" format? The DIGEST format takes every day's email, rolls it into a single email, and sent it to you at once, rather than a bunch of individual emails. Personally, I prefer individual emails so I can easily see the subject and reply to them that way, but lots of people like the digest version for it's compactness. If you want to be set up on the digest version, drop me a note and I can make the change. You can also change to either normal or digest versions yourself by doing this:

- To switch your subscription to digest, send a blank email (with nothing in the subject or message body, and no signature) to:
teara-digest@yahoogroups.com
- To switch your subscription back to the normal delivery, send a

blank email (with nothing in the subject or message body, and no signature) to:

teara-normal@yahoogroups.com

[TIPS for using the Digest Version]

- **1)-** When replying to a digest message, be sure to take a look at the subject line. It'll usually state the digest # it's replying to, rather than the individual message within the digest. Change the subject to reflect what ever topic you're replying to, so folks will know what the message is about.
- **2)-** When you click "reply" to a Digest message, everything in the digest will be captioned or quoted as part of reply. Be sure to highlight and delete the rest of the digest that doesn't pertain to your specific reply, so the email (if you're clicking "reply") won't contain a bunch of other messages. That'll also help keep the email as small as practical.

[ARCHIVES]

 The TEARA list has mail archives of all the traffic on the list. These can be accessed with a web browser like Netscape or Internet Explorer. This could be helpful if you're looking for a missed note, or maybe at another terminal somewhere (public library, work, friend's house, etc) and want to check in to see what's going on. There is also an archive storing every digest of every message ever sent on the nevulcan list.

- **To get to todays messages, click --> [HERE](#)<-- !**

 I hope these tips improve or supplement your enjoyment of the TEARA list!

Webmaster: webmaster@teara.org

[RETURN](#) to the main TEARA Webpage!



[Home](#) -> Antennas[Wire-Yagi](#) [More-Yagis](#) [LPDA](#) [Six-Meters](#)

Welcome to VE7CA's Antennas Page

Since becoming an amateur radio operator I have built a lot of antennas. I have had several articles published where I described antennas that have served me well. The above menu bar will take you to the articles.

December, 2003

One hour before the 2003 CQWW CW Contest, I decided to raise the telescoping tower that supports my modified Telerana LPDA, 30/40 meter dipole and 6 meter yagi. Just before it reached max height the tower collapsed into its self and came down with lightning speed. With the rapid deceleration and then sudden stop, the outer ends of the booms and fiberglass spider supports kept moving downward and broke a couple of the poles. The damage is evident in the photo below. This is a reminder to those who own crank up towers, check the cable, cable fasteners and winch brakes regularly!

Fortunately, no damage to VE7CA or the skylight through which I was watching the tower as I operated the switch that controls the electric winch.

August 23, 2004

After lowering the tower to determine why the tower collapsed, I found that the raising cable broke where it entered the electric winch. Why it broke I have no idea. There was also damage to the bottom ends of the each section where the winch cables are attached. I am in the process of repairing the damage and hope to have the tower up by the end of September 2004.

I am also in the process of designing a new antenna to replace the Modified Teleranna. Since I have been concentrating on QRP contesting of late, I have decided that I need an antenna with higher gain in the CW portions of 20, 15 and 10 meters. As well, gain on 40 meters would be much appreciated. I will keep you posted on my progress as I near a new design.



160/80m Coaxial Receiving Loops

NOTE: As of January 1, 2004 I must raise the price of my receive loops. As that my construction costs, have risen.

Several years ago a friend of mine (W7AE) and myself became interested in low band dxing. Lacking room for a beverage receiving antenna, we constructed several loop receiving antenna to see if we could find a suitable low /lower noise receiving antenna.

W7AE built the first loop for 160m following plans laid out in the ARRL Antenna Handbook. Encouraged by the results I built one for 80m. I found that with a proper pre-amp, such the Palomar series, or Ameco's PT-3 there was a significant lowering of noise, but the signals that I was unable to hear on my sloper now were quite workable using the receiving loop. For the past several years, we experimented with several different configurations , including a circular, and square loop. We found that the diamond configuration worked the best. The 80m version requires a pre-amp to bring the signal up to an acceptable quality. We've found that there is a one to two s unit difference (depending how high you set the gain on the preamp)in the lowering of noise. There have been several times that the loop has made the difference between working a DX station or not hearing him on my sloper. Though the antenna is not a beverage, we've found it to be a good alternative.



[Click Here](#) If you want me to construct one for you.

[Click here](#) If you wish to build one yourself.

[Low Band Links](#) (Presently under reconstruction.)

The latest news, is that now I can accept Paypal. Click on the link that says "If you want me to construct one for you" for more details.

Please note that there is a new e-mail address and price increase on the 160/80m loop. (Component prices seem to be going up.)

Your are visitor number



updated 08/22/2001



© 2003 by Spencer F. Ritchie



- [Home](#)
- [Members](#)
- [Our Club](#)
- [Hamfest](#)
- [Site Map](#)
- [Repeaters](#)
- [Contact Us](#)

Super Linear - Loaded Inverted V

[[Home](#)] [[Our Members](#)] [[Our Club](#)] [[Greater Buffalo Hamfest](#)] [[Ham Radio Information](#)] [[Ham Radio News](#)] [[Contact US](#)]

[[Standard Dipole Construction](#)] [[Super Loop Antenna](#)] [[J - Pole](#)] [[Pocket J - Pole](#)] [[Quickie Vertical](#)]
[[Super Linear - Loaded Inverted V](#)]

The KGØZP Super Linear-Loaded Inverted V

How do you fit a full length 160 meter antenna into a 40 foot deep yard?
Install the KGØZP Super Linear-Loaded Inverted V, of course!

The Super Linear-Loaded Inverted V allows you to select your two favorite and most used frequencies as band centers, and offers excellent bandwidth as well.

The designers installation centerpoints are set at 1.840 the center of the DX window or calling frequency and 1.875 at an SWR of 1.1-1
The bandsread at 1.5-1 is 20 kc at each center or
40 kc to an SWR of 2-1

The linear-loading section is mounted near enough to the ground that you can easily install or remove precut pigtailed using an alligator clip to move the center point temporarily to make that sked, or you can tune the whole 160 meter band with a simple antenna tuner.

The formula for construction is the same as for any dipole $468/f\text{Mhz}$ and the design will work equally well on 80 or 40 meters.

Reader Please Note: The photos on this page are greatly compressed to insure quick downloading.
The link accompanying each photo will cause the uncompressed full size photo to download.

It would be impossible to show an overall view of the whole antenna system in such a way that you could see the wires.

With that in mind, I have taken a couple of daylight pictures as well as flash night pictures which allowed me to highlight the wires against a black sky.

Lets take a thumbnail look at a daylight view of the Rohn 50 foot push-up pole utilized for this installation.

This is quite a busy photograph, so I will name the items in descending order to help pinpoint the areas relavent to the Super Linear-Loaded Inverted V.



[Weather Station](#)

[Radio Nets WNY](#)

[News Letter](#)

[Club Calendar](#)

About [Ham Radio](#)

[Shortwave Radio](#)

[Dunkirk Lighthouse](#)



[Blizzard of '77](#)



The white stick at the top extending off the upper edge of the photo is a Diamond Tri-bander, model X3200A, fed with 9913 coax.

Directly below the tribander is the first guying ring. This is a dummy ring is used to ground and hold the upper wire of a Wermager type Broadband Sloper. In the full sized photo you can just barely see this wire extending left forward.

The highest of the three actual guying rings (second one down from the top) is at the 40 foot high point on the tower, a pulley is connected to this guying ring and through it is threaded a high quality flagpole rope. This rope can be used to raise and lower the balun for experimenting with different antenna designs, without changing the position of the push-pole.

The Super Linear-Loaded Inverted V, the topic of discussion is connected to this balun. The tension on the wires is so great that it holds the balun outward, the line descending from the bottom of the balun is Super Mini-8 coax. The pull of the Inverted V's two antenna wires is offset by two guywires on the other side of the guying ring. I have a wide yard and could keep the apex slightly wider than 90 degrees.

The next guy ring down is at the 30 foot height point and has nothing more three guy wires.

The lowest guy ring visible in the photograph is at the 20 foot level, and is the feedpoint for the Fan portion of a Wermager type Broadband Sloper originally used on 160 but now cut for 80 meters. I would like to mention again that the upper wire of the Wermager type Broadband Sloper is the wire grounded to the push-pole at the dummy guy ring at the very top. The other end of this wire is tied to the same location as the guy wire coming from the 30 foot guy ring, which places the metal



guy wire directly between the driven Fan and the grounded sloper element of the Wermager type Broadband Dipole.

This photo is a view showing the East outbound leg of the Super Linear-Loaded Inverted V. In the upper left of the photo, you can see the single sloping wire descending from the balun. The two horizontal wires below comprise part of the Linear-Loading section.

The remaining photo's were taken at night using a flash, then enhanced to make the wires more prominent.

In this first photo, you can easily see that the Linear-Loading section is a good distance away from the push-pole. I used a distance of 5 feet in this installation, but you can reduce this distance to 3 feet if necessary. The vertical spacers are drinking straws, one nested inside the other for greater strength, a nylon tie line is fed through the center of the straws.

The upper tie off lines are located 1 foot above the standoff mounted to the eave. The lower tie off lines should also be located at or just above the standoff. Original twine used during initial setup is still visible and should have been removed before taking the photo.



The white insulator some 5 feet above the linear loading section is the feedpoint for the Fan portion of the Wermager type Broadband Sloper.



SPECIAL NOTATION: The upper wire and the lower wire of the linear-loading section are connected at this end only. This will be described in greater detail in the construction notes section.

Super Linear-Loaded Inverted V.

These last two photos show the East and West outbound ends of the

If you look closely, you can see the pigtails wrapped around the lower nylon guys.



In the photo on the left of the East outbound end, the wire from the balun down to the insulator is not visible. The upper guy wire from the insulator is metal, the lower is nylon. An additional twisted wire above the insulator is used to lift the linear loading section slightly higher than the existing guy mount allows, I did this only because I had something above each outbound end to tie to.



The right photo shows slightly greater detail and the antenna wire from the balun is clearly visible. There are no electrical connections at the outbound end of the linear-loading section.

Again, if you look closely, you can see the pigtail extension wrapped around the lower nylon guy.

Construction Notes:

The construction of the Super Linear-Loaded Inverted V is quite simple and follows the same formula as for a standard dipole. $468/f\text{Mhz}$ (FourHundredSixtyEight divided by the Frequency in Megahertz give you the total length in feet for a 1/2 wave dipole). In practice you will use two wires, each being 130 feet long. The antenna shown in the photos is made from 14 guage insulated copper wire. I ran out of insulators and am temporarily using loops made from 1/4 inch nylon cord at the push-pole end of the linear-loading section. If you start with two 130 foot long wires, you do not have to measure the turning or ending points, they will fall in place depending upon the height you install the horizontal portion of the antenna.

The height of the feedpoint can vary considerably, however, the higher the better. If you can only go up 30 or 35 feet, the antenna will still perform almost as well, but you will require a further horizontal distance to work in. With the feedpoint at 40 feet, the sloping elements are roughly 60 feet long at 40 feet away from the push-up pole. Any distance from 40 feet to 80 feet in length seems to make little difference in the performance of this antenna.

A balun is not an absolute necessity, however, if space constraints keep you from obtaining a spread between the sloping wires greater than 90 degrees, then a balun is strongly suggested.

For all practical purposes, installation is the same as for an inverted V, a feed type insulator or balun is assembled with the coax and both of the 130 foot long wires. Connection of the coax is the same as for a standard dipole. The center conductor goes to one wire and the shield to the other wire. The feed insulator or balun is now hoisted to it's permanent position on your push-pole, tower, gable or wherever you are mounting your antenna.

I will describe the finished setup first, then give some quick install tips immediately following.

One side of the antenna is assembled first and will require a minimum of three insulators or you can use nylon mounts by giving the wire a twist to form a loop to connect the nylon rope to.

The antenna wire is brought out across the yard and the end of the wire is passed through an insulator at the outbound end of the antenna. The antenna wire is then brought back toward the push-pole and passed through the second insulator. The second insulator should be installed about 6 feet away from the push-pole temporarily. The wire then passes through a third insulator 6 to 8 inches below the second insulator, and then proceeds back out to the outbound end.

The ideal installation would have the feedpoint 50 feet above ground level and the linear-loading section 20 feet above ground level. In practice, the feedpoint can be as low as 30 feet above ground level and the linear-loading section as low as 10 feet from the ground without affecting performance to drastically. In any case, the linear-loading section should be maintained as close to horizontal as possible.

The idea is to determine at what height you wish to install the horizontal linear-loading section, and then adjust the insulators and distance between the push-pole and inside end of the linear-loading section so that the first insulator and end of the wire are on the same plane. And you'll really love this, give or take 2 or 3 feet on that tail, preferably give a few feet extra for trimming to resonance.

Any non-metal spacer can be used to maintain distance between the elements of the linear-loading section! No need to go overboard here, it's close enough to the ground you can replace the simple item I use in Quick Tips below.

Simple Sketch showing path of antenna wire on one side of balun.

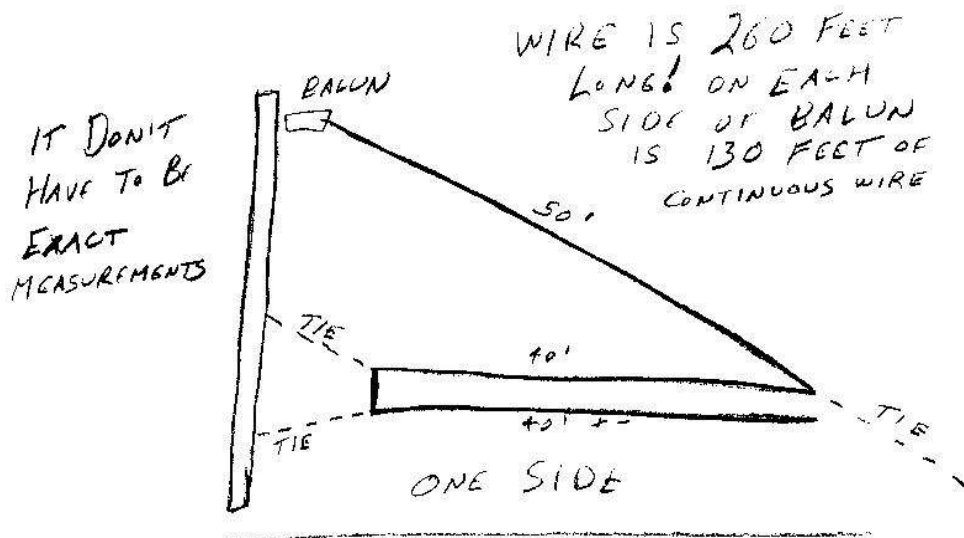

Quick Tips:

Here is how to install this antenna system and have it up and running in well under an hour, exluding push-pole installation of course.

1. Install the wires to your balun and connect the coax, hoist it into position and secure firmly.
2. Pull one wire out taught to your guy mount and secure temporarily.
3. Take the loose end of this same wire and secure it to the push-pole temporarily at the desired final installation height. Note: This end of the wire will be at the other end of the yard when finished.
4. Go back to the outbound end of the antenna, using a stepladder if necessary, pull the wire so that it is taught from the push-pole and lift the wire until it is perfectly horizontal.
5. With a magic marker or piece of tape, mark the sloping wire at the point where the wire from the push-pole crosses the sloping wire. This is where the outbound insulator is to be installed.
6. Install the outbound insulator and tie off (guy) this portion of the antenna to permanent tension.
7. Disconnect the loose end of the wire from the push-pole, pass it through an insulator and bring the loose end out to the outbound end and temporarily connect it to the now secure insulator outbound insulator, leaving 2 to 3 feet of loose pigtail extending through this insulator.
8. Pull the wires from the insulator toward the push-pole until they are in balance at equal lengths from the outbound end, at this bend take the insulator and give it a twist, release the loose pigtail at the outbound end, then secure the push-pole end of the top linear-loading wire and it's insulator to the push-pole at it's permanent position.
9. Install your first spacer (see spacers below) by passing the loose end of the wire through it, bring it up snug to the insulator, install the second insulator and give it a twist to hold it secure. Tie this insulator off to the push-pole as well, trying to keep the spacer vertical.
10. Install additional spacers, one about every five feet, to maintain separation of the upper and lower linear-loading sections.
11. When you reach the outbound end, install your last spacer at the insulator, form a loop in the lower wire for attaching a nylon tie off rope. Pull the rope to tighten the lower linear-loading wire and tie off to the guy mount. Wrap the remaining 2 or 3 feet of pigtail around the nylon rope.
12. Duplicate the above instructions for the other leg of the antenna!

SPACERS:

I take simple drinking straws to use for spacers. But reinforce them to two thicknesses for all the spacers except the inbound spacer near the push pole, this one is three or four thicknesses.

To strengthen a soda straw, you merely slit another soda straw end to end and insert it inside of the whole unslit soda straw. You only need to pass the unslit whole soda straw over the wire for the inbound spacer, the other two or three slit straws can be added right over the wire and then slid into the whole unslit straw.

Joining the straws to the wires:

I take 24 inch long pieces of braided nylon, like mini-blind sash cord, fold it in half, hold it on one side of the top wire with the loop up and open, then I pass the loose ends of the rope over the wire and through the loop, pull it snug and let the ropes hang until I get all the ties (ropes) installed.

By taking a 12 inch long piece of 18 or 20 guage wire and bending a sharp turn at one end, you can use that to slip the ends of the ropes into and slide the soda straw over the wire pulling the rope down through the straw. Place the loose ends of the rope one on each side of the lower wire and tie a square knot, drawing the wire up tight against the soda straws. Don't worry if they are a bit right now, you can true them up later.

After the antenna is assembled, tied down nice and snug, and tuned. I will adjust the soda straws to vertical and place a dab of something like plasti-dip-your-grip or dumb gum over the tops of the straws to hid the nylon braid from UV and weather.

I usually don't worry about the knot end or lower end of the straw.

Tune-Up:

If I have obstructions in the yard that interfere more with one leg than the other, I will make the shield side of the coax go to that side and the center conductor to the clearer of the legs. Now I tell you!

I normally tune both legs of the antenna first to 1.840 MHz, then I will continue to cut the clearer leg of the antenna all the way down to 1.950 MHz. I will then make a pigtail with an alligator clip on it and retune that leg of the antenna to 1.875 MHz. You can wrap the pigtail around the nylon guy and slide it down at least 6 inches away from the tuned pigtail end and it won't interfere with your upper band setting. In my case, I leave the pigtail connected as 1.875 MHz is one of my popular areas of the band for ragchewing. I may be over 50, but to really fit in up at 1.950, I need another 40 years under my belt, Hi Hi..... You may make other pigtails to center in other areas of the band also. It works on either leg of the antenna!

TTUL - 73+ de Gary - KGØZP

Questions or comments may be e-mailed directly from the home (index) page.

© 1999 Gary V. Deutschmann, Sr. - SCS/RAIAR



Amateurfunk

Ham Radio

Antennas

Operator: Norbert Prenzel (DJ9RB - VU2RBQ - H44 / DJ9RB)

Short Dipoles and Verticals

- [160m Band, Loaded Dipole](#)
- [160m Band, Loaded L-ANT \(Pattern\)](#)
- [160m Band, Kite with Vertical Antenna](#)
- [80m Band, Short Dipole](#)
- [80m Band, Top Loaded Vertical](#)
- [80m Band, Top Loaded Vertical](#)
- [80m Band, Shielded Loop](#)
- [40m Band, Top Loaded Vertical](#)
- [40m Band, portable with Top Load](#)
- [40m Band, portable Dipole](#)
- [40m Band, Loop-magnetic](#)
- [Antenna Measure Instruments](#)

Verkürzte Antennen (160m, 80m, 40m)

- Dipol mit Endkapazität
- L-Antenne mit Endkapazität
- Drachen mit Vertikalantenne **full size**
- kurzer Dipol für das 80m Band
- Vertikalantenne mit Dachlast, 8m hoch, $f = 3,5$ MHz
- using elevated radials** - Radials 1m über Grund **new**
- abgeschirmte Loop für 3,5 MHz
- Vertikalantenne mit Dachlast, 7m hoch, $f = 7$ MHz
- Portabel-Antenne mit Dachlast, 6m hoch, $f = 7$ MHz
- Portabel-Dipol, $f = 7$ MHz
- Loop (verkürzte Rahmenantenne), $f = 7$ MHz (80,40,30 m)
- Eigenbau Meßgeräte

Pictures

- [VU2*India - Location \(QTH\)](#)
- [VU2*India - TOP LOAD](#)
- [Radio Operator](#)
- [H44*Solomon Isl - QTH](#)
- [H44*Solomon Isl - Equipment](#)
- [H44*Solomon Isl - Equipment](#)
- [H44*Solomon Isl - OPERATORS](#)

Fotos

- 80m Band Vertical on Top of the Hotel
- Sphere from the 80m Band Vertical
- Norbert DJ9RB (VU2RBQ)
- at Faisi Island
- is running from Battery
- Shack (Funkraum)
- H44 / DJ9RB** , H44MS (DL2GAC)

Activity

Aktivitäten

[INDIA](#) [Log 160m](#) [Log 1996-2004](#) 
[Fly a Kite with Antenna adapted](#)

[Log from VU2RBQ \(VU2 / DJ9RB\)](#)
[Drachen mit Antenne im 160m Band](#)

Nostalgia

[Wiring Diagram and Pictures](#)

Mein erster Sender

[Schaltplan meines Eigenbausenders aus dem Jahr 1964 und Fotos](#) **new**

Links

[VU2RBQ Norbert](#)
[DL0PW](#) [OV-Würmsee \(Starnberger See\)](#)
[DL2UV and other Links](#)
[DF3CB Homepage](#)

DX

[HF-Cluster](#) [DX-Info 160m ... 10m](#)
[DX-Info QSL.Net](#)
[more Links](#)

Propagation

[Solar Terrestrial Report](#)
[MUF-Map](#) [Propagation](#) [WWV](#)

[dj9rb @ arcor . de](mailto:dj9rb@arcor.de)

28.03.2001 **4 2 9 3 8** 28.03.2001

[Start was at 24.10.1996](#)

[Last change on: Aug.2004](#)



Half-Length 80-Meter Vertical Monopoles: the Best Method of Loading



L. B. Cebik, W4RNL

Summary

In the pursuit of obtaining the most compact and efficient 80-meter monopole antenna, numerous loading schemes have been proposed, including based lumped constant loading, base linear loading, top (capacity) hat loading, and a number of antenna element extension-and-fold-back systems. Modeling these systems is difficult due to the various limitations of existing modeling software, including MININEC, NEC-2, and NEC-4.

Preliminary work is best done in MININEC, because (with due caution) it is best capable of modeling nonlinear geometries employing wires of different diameters, a necessary condition of a compact 80-meter monopole. A monopole 37.5' long, corresponding to a common commercial height, is the constant main element used, with other parameters varied to achieve the following goals:

- a. Maximum gain within the limits of the antenna type;
- b. True vertically-polarized circular pattern;
- c. Highest feedpoint impedance for maximum efficiency;
- d. Flattest SWR curve between 3.5 and 3.7 MHz; and
- e. Most compact and mechanically practical assembly.

The range of models compared covered the following types of monopoles: full-length, 37.5' unloaded, lumped constant base-loaded, linear-base-loaded, "capacity" hat loaded; top linear loaded; zig-zag fold-back loaded, and helically loaded. Figures are provided on gain and feedpoint impedance at 3.6 MHz, as well as on feedpoint impedance and SWR at 0.05 MHz intervals from 3.5 to 3.7 MHz. Other data can be obtained from these models by rerunning them using the descriptions provided in an Appendix. Especially recommended is a study of current levels along the antenna wires.

No single model antenna achieves all of the goals listed above. However, the helical fold-back element extension model achieves goals a. through c., and perhaps holds promise of achieving e. The zig-zag fold-back element extension model excels in achievement of goals b, c. and d., with only slightly less gain

than the helix and with some promise of meeting goal e. The capacity hat model shows excellent gain, bandwidth, and feedpoint impedance, but may be mechanically problematical except in a Marconi configuration. All other models show lesser performance in one or more categories. Unless mechanical constraints preclude further work on them, the helical and the zig-zag foldback models appear to be the best candidates for further study and testing. However, before hats are discarded as too large or too fixed or too unwieldy, the spiral hat noted in the last segment (Part 5) should be examined. It was modeled in NEC-4 because the model was too large for standard MININEC.

[1. Goals, and Methods of the Study](#)

[2. Baseline Data: Full-Size and Capacity-Hat Verticals](#)

[3. Base-Loading: Lumped-Constant and Linear Loading](#)

[4. Top \(Element-Extension\) Loading: Linear, Zig-Zag, and Helical Loading](#)

[5. Summary Comparisons and Conclusions; With an Alternative Suggestion](#)

[6. Descriptions of Models Reported](#)

Updated 5-12-97. © L. B. Cebik, W4RNL. Data may be used for personal purposes, but may not be reproduced for publication in print or any other medium without permission of the author.



[Go to Amateur Radio Page](#)

[Home](#)[Members](#)[Our Club](#)[Hamfest](#)[Site Map](#)[Repeaters](#)[Contact Us](#)

[[Standard Dipole Construction](#)] [[Super Loop Antenna](#)] [[J - Pole](#)] [[Pocket J - Pole](#)] [[Quickie Vertical](#)]
 [[Super Linear - Loaded Inverted V](#)]

Super loop 80

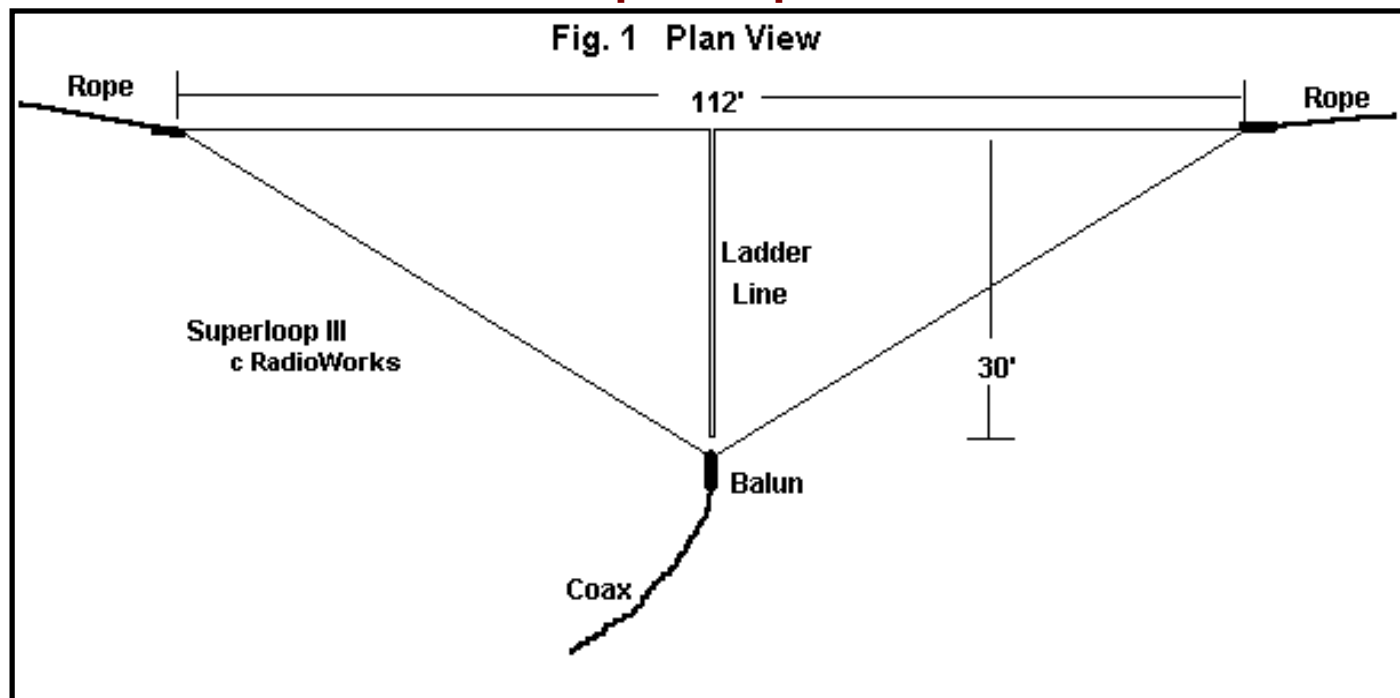

G5RV versus Superloop 80

Many operators with small lots, a G5RV is what can fit for the 80 and 40 meter bands. The G5RV is 102 feet long and has a 34 foot section of twinlead followed by coax into the shack, possibly with some sort of RF choke on the coax. The ends are typically supported by ropes up in the trees. An 80 meter dipole would be about 134 feet long.

A tiny lot is limited in antenna potential and zoning laws prevent real towers.

RadioWorks "Superloop III" designed by Jim, W4FTU, and refined over the years, is a good alternative

PHYSICAL VARIATIONS

The standard arrangement is shown in Fig. 1. It looks like an inverted delta loop and is 112 feet across the top. It fit on the same ropes as my G5RV used and the coax even started at about the same point in space. The wire is heavy 14 gauge copper. If your space doesn't quite allow this, the top corner insulators can be moved to shorten the 112 foot dimension; also additional insulators can be added to the diagonal wires to make a rectangular

shape and raise the bottom balun up in the air more. I also added 6 feet of wire to move the resonant freq closer to the band bottoms for digital work.

The loop can also be mounted upside down and slanted if you only have a single support available. As with all loops, the area enclosed is important and so is the average height; the standard inverted delta shape is a very good compromise.

ELECTRICAL CHARACTERISTICS

The "trick" to the Superloop is the 30' length of ladder line hanging down from the center insulator. This length has been tuned so that appears to be a open-circuit stub on 40 meters; thus the antenna becomes two full-wave wires (at 40 meters) and is commonly referred to as the Bi-Square antenna. On 80 meters, it appears to be a short and the antenna becomes a single wave vertical loop. This happens automatically and no switching is involved.

A special balun is provided which gives a match between the 50 ohm coax lead-in and the higher resistance of the loop. For best matching, a 1/2 wavelength coax is recommended (e.g. 99' of RG-8X); however mine is about 70 feet into my diff-T tuner and the SWR < 2 points are 3495 to 3787 but the short coax gives a minimum on 40 of 2.05 at 7090 KHz. If you need to run without a tuner, close attention to the coax length will help. The balun is the typical ferrite rod in a PVC pipe with foaming urethane inside. This has the effect of heat insulating; mine works fine on 500 RTTY watts contesting, but real high power may be a problem on RTTY; but those guys all have beams, right?

OPERATING RESULTS

The diagonal wires make it partially a vertical antenna with a nice reduction in polarization QSB. You can possibly double contacts on 80/40 over the G5RV. RITTY can help on the reception. The Superloop tunes up fine on the 20,15,10 bands Antenna, ropes, and coax will run you about \$US 135. RadioWorks advertises in CQ and QST and have an interesting catalog.

[[Home](#)] [[Gtr Buffalo Winter Hamfest](#)] [[How To Become a HAM](#)] [[Licence Testing](#)] [[Exam Schedule](#)]
[[ARRL Atlantic Division](#)] [[Building Antennas](#)] [[Q Signals - Prosigns - Abbreviations](#)] [[Licence Restructuring](#)]

The NJQRP Squirt

This reduced-size 80-meter antenna is designed for small building lots and portable use. It's a fine companion for the Warbler PSK31 transceiver.

At one time, 80 meters was one of the more highly populated amateur bands. Lately, it has become significantly less popular because much DXing has moved to the higher frequencies and many suburban lot sizes are too small to accommodate a full 130-foot, $\lambda/2$ antenna for the band. That's unfortunate, because 80 meters has lots of potential as a local-communication band—even at QRP levels. The recently published Warbler PSK31 transceiver can serve as a great facilitator for close-in QRP communication without much effort.¹ What's really needed to complement the Warbler for this purpose is an effective antenna that fits on a small suburban plot. Because PSK31 (which the Warbler uses) is reasonably effective even with weak signals, we can trade off some antenna efficiency for practicality.

What's a Ham to Do?

I investigated a number of antenna possibilities to come up with a practical solution. One intriguing candidate is the magnetic loop. Plenty of design information for this antenna is presented in *The ARRL Antenna Book* and at a number of Web sites.^{2,3} To obtain high efficiency, however, the loop must be 10 feet or more in diameter and built from 1/2-inch or larger-diameter copper pipe. The loop needs a very low-loss tuning capacitor and a means of carefully tuning it because of its inherently narrow bandwidth. Another configuration, the DCTL, may be a solution, but it's likely not very efficient.⁴

An old standby antenna I considered is the random-length wire worked against ground. If it is at least $\lambda/4$ long (a Marconi antenna) or longer, it can be reasonably efficient. Shorter lengths are likely to be several S units down in performance and almost any length end-fed wire needs a significant ground system to be effective. Of course, you may not need much of a ground with a $\lambda/2$ end-fed wire, but it's as

long as a center-fed dipole.

Vertical antennas don't occupy much ground space, but suffer the same low efficiency as the end-fed wire if they are practical in size.

Probably the easiest antenna to use with good, predictable performance is the horizontal center-fed dipole. Unfortunately, as mentioned earlier, the usual 80-meter $\lambda/2$ dipole is too large for many lots. But all is not lost! The dipole can be reduced to about a quarter wavelength without much sacrifice in operation (see the sidebar, "Trade-Offs"). Furthermore, if the dipole's center is elevated and the ends lowered—resulting in an inverted V—it takes up even less room. This article describes just such a dipole: the NJQRP Squirt.

V for Victory

You can think of the Squirt as a 40-meter, $\lambda/2$ inverted-V dipole being used on 80meters. Figure 1 is an overall sketch of the antenna; Figure 2 is a

photograph of a completed Squirt prior to erection. The Squirt has two legs about 34 feet long separated by 90° with a feed line running from the center. When installed, the center of the Squirt should be at least 20 feet high, with the dipole ends tied off no lower than seven feet above ground. This low antenna height emphasizes high-angle NVIS (Near Vertical-Incidence Skywave) propagation that's ideal for 80-meter contacts ranging from next door out to 150 or 200 miles. And



Figure 2—An assembled Squirt ready for installation.

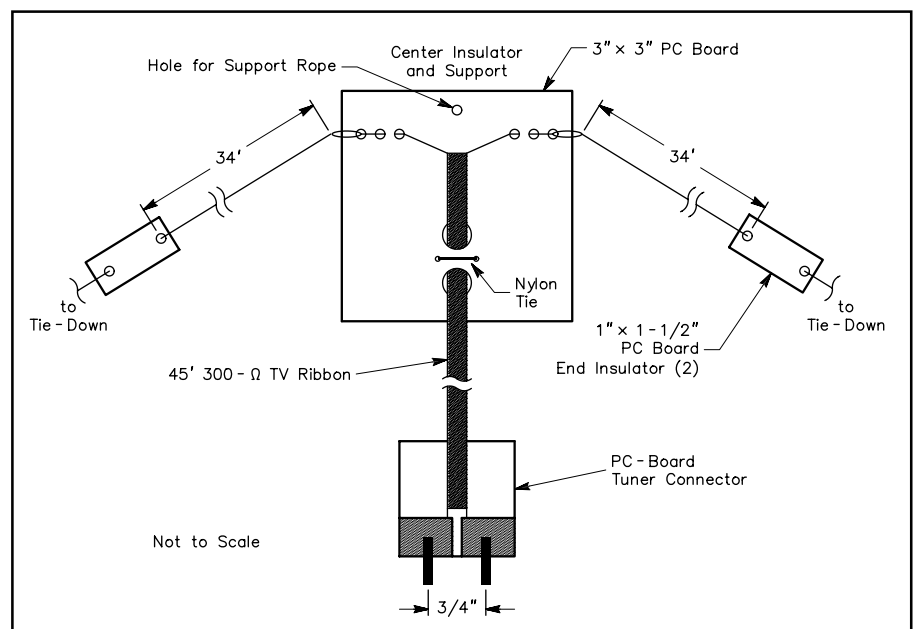

Figure 1—General construction of the 80-meter Squirt antenna.

¹Notes appear on page 43.

that's where 80 meters shines! With the Squirt's center at 30 feet and its ends at seven feet, the antenna's ground footprint is only about 50 feet wide.

One nice feature of a $\lambda/2$ center-fed dipole is that its center impedance is a good match for 50- or 75- Ω coax cable (and purists usually use a balun). Ah! But the Squirt is only $\lambda/4$ long on 80 meters, so it *isn't* resonant! Its feedpoint imped-

ance is resistively low and reactively high. This means that feeding the antenna with coax cable would create a high SWR causing significant feed-line loss. To circumvent this, we can feed the antenna with a low-loss feed line and use an antenna tuner in the shack to match the antenna system to common 50- Ω coax cable. I'll have more to say about the tuner later.

I use 300- Ω TV flat ribbon line for the feed line. Although a better low-loss solution is to use open-wire line, that stuff is not as easy to bring into the house as is TV ribbon. Using TV ribbon sacrifices a little transmitted signal for increased convenience and availability. If you feel better using open-wire line, go for it!

Using Available Materials

It's always fun to see what you can do with junkbox stuff, and this antenna is one place to do it. See the "Parts List" for information on materials and sources.⁵ For instance, the end and center insulators (see Figure 1) are made of $1/16$ -inch-thick scraps of glass-epoxy PC board. For the antenna elements, I use #20 or #22 insulated hookup wire. Although this wire size isn't recommended for use with fixed antennas, I find it entirely adequate for my Squirt. Because it's installed as an inverted V antenna, the center insulator supports most of the antenna's weight making the light-gauge wire all that's needed. The small-diameter wire has survived quite well for several years at N2CX. This is not to say, of course, that something stronger like #14 or #12 electrical house wire couldn't serve as well.

The 300- Ω TV ribbon can be purchased at many outlets including RadioShack and local hardware stores. Once again, if you want to use heavier-duty feed line, do so. The only proviso is that you may then have to trim the feeder length to be within tuning range of the Squirt's antenna tuner.

The End Insulators

I used $1/2 \times 1 1/2$ -inch pieces of $1/16$ -inch PC board for the Squirt's two end insulators. As with everything else with the Squirt, these dimensions are not sacred; tailor them as you wish. If you use PC board for the end insulators, you have to remove the copper foil. This is easy to do once you've gotten the knack. Practice on some scraps before tackling the final product. The easiest way to remove the foil without etching it is to peel it off using a sharp hobby knife and needle-nose pliers. Carefully lift an edge of the foil at a corner of the board, grasp the foil with the pliers and slowly peel it off. You should become an expert at this in 10 or 15 minutes. Drill $1/8$ -inch-diameter holes at each end of each insulator for the element wires and tie-downs.

Tuner Feed-Line Connector

The tuner end of the feed line is terminated in a special connector. Because the TV-ribbon conductors aren't strong, they'll eventually suffer wear and tear.

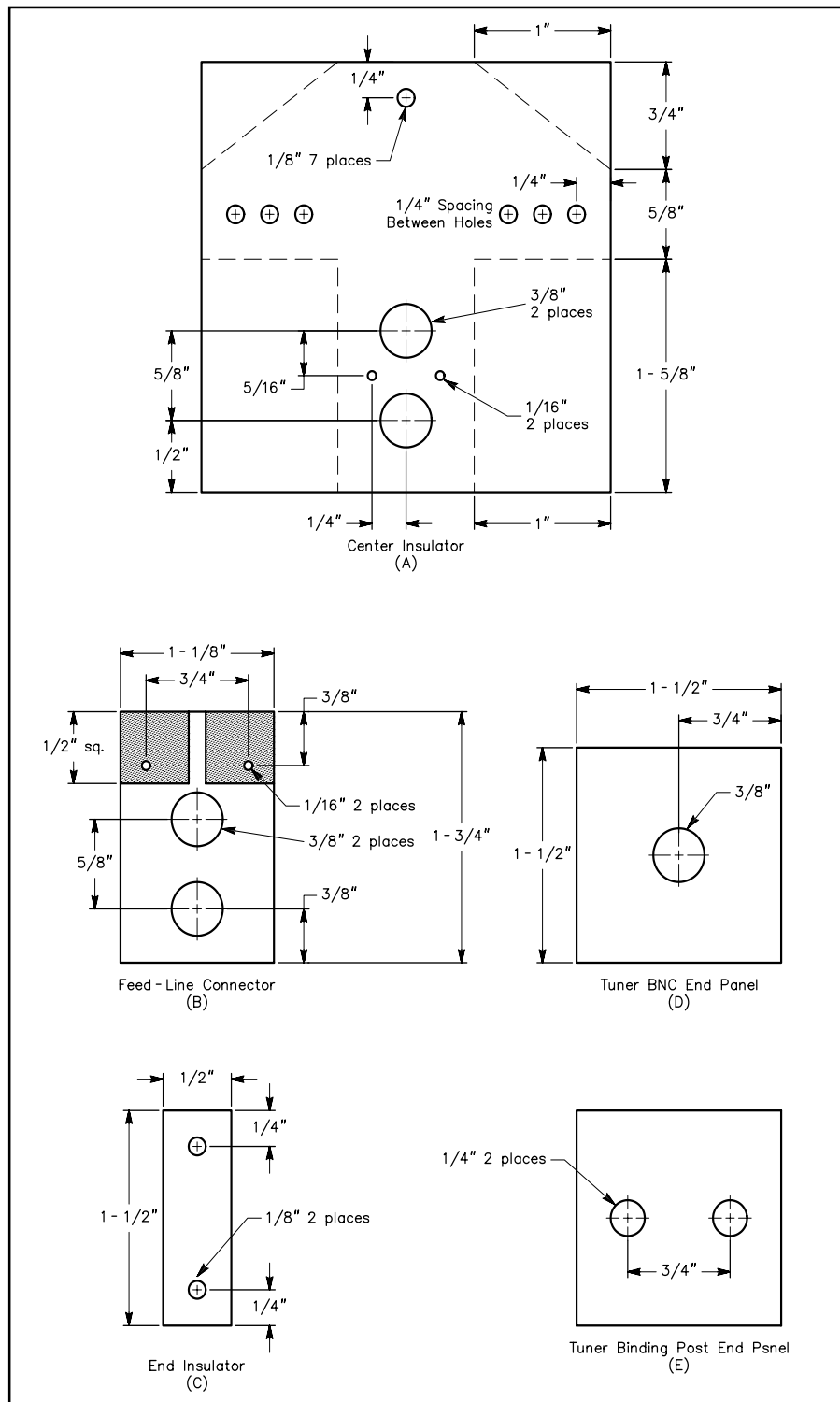

Figure 3—Hole sizes and locations for the various PC-board pieces. See Note 5.

Trade-Offs

One of the unfortunate consequences of shrinking an antenna's size is that its electrical efficiency is reduced as well. A full-size dipole is resonant with a feedpoint impedance that matches common low-impedance coax quite well. This means that most transmitter power reaches the antenna minus only 1 dB or so feed-line loss. However, when the antenna is shortened, it is no longer resonant. A *NEC-4* model for the Squirt shows that its center impedance on 80 meters is only about 10 Ω resistive, but also about 1 k Ω capacitive. This is a horrendous mismatch to 50- Ω cable, and feed-line loss increases dramatically with high SWR. The Squirt uses 300- Ω TV ribbon for the feed line with an inherently lower loss than coax. This loss is much less than if coax were used, but it's still appreciable. Calculated loss with 300- Ω transmitting feed line is about 7.7 dB (loss figures are hard to come up with for receiving TV ribbon) so the feed line used doubtless has more than that.

Although this sounds discouraging, it's *not fatal*. You have to balance losing an S unit or so of signal against not operating at all! Consider that the Squirt, even with its reduced efficiency, is still better than most mobile antennas on 40 and 80 meters. So for local communication (a low-dipole's forte), using PSK31 and the Squirt is quite practical.

If you don't already have an antenna, the Squirt's a good choice to get your feet wet when using PSK 31. Once you get hooked, you'll probably want a better antenna. If you have the room, put up a full-size dipole; you'll see the improvement right away. If you can't do that, use a lower-loss feeder on the Squirt, such as good-quality open wire.—Joe Everhart, N2CX



Figure 4—The pad side of the home-made feed-line-to-tuner connector.



Figure 5—Here the feed-line-to-tuner connector is shown attached to the binding posts of the Squirt antenna tuner.

This connector provides needed mechanical strength and a means of easily attaching the feed line to the tuner. In addition to some PC-board material, you'll need four or five inches of #18 to #12 solid, bare wire. Refer to Figure 3 and the accompanying photographs in Figures 4 and 5 for the following steps.

Take a $1\frac{1}{8} \times 1\frac{3}{4}$ -inch piece of single-sided PC board and score the foil about $\frac{1}{2}$ inch from one end; remove the $1\frac{1}{4}$ -inch piece of foil. Now score the remaining foil so you can remove a $\frac{1}{8}$ -inch-wide strip at the center of the board, leaving two rectangular pads as shown in Figures 3B and 4. Drill two $\frac{1}{16}$ -inch-diameter holes in the copper pads spacing the holes about $\frac{3}{4}$ -inch apart. Drill two $\frac{3}{8}$ -inch holes at the connector midline about $\frac{5}{8}$ -inch apart, center to center, to pass the feed line and secure it.

Cut two pieces of #18 to #12 wire each about three inches long. Pass one wire through one of the $\frac{1}{16}$ -inch holes in the connector board and bend over about $\frac{1}{4}$ -inch of wire on the nonfoil side. Solder the wire to the pad on the opposite side and cut the wire so that about one inch of it extends beyond the connector. Repeat this procedure with the second wire. Next, strip about two inches of webbing from between the feed-line conductors and loop the feed line through the two $\frac{3}{8}$ -inch holes so that the free ends of the two conductors are on the copper-pad side. Strip each lead and solder each one to a pad. You now have a solid TV-ribbon connector that mates with the binding-post connections found on many antenna tuners. Figure 6 shows the connector mated with a Squirt tuner.

Center Insulator

Strip all the foil from this 3-inch-square piece of board. Use Figure 3A as a guide for the hole locations. The top support hole and the six wire-element holes are $\frac{1}{8}$ -inch in diameter; space the wire-element holes $\frac{1}{4}$ -inch apart. The feed-line-attachment holes are $\frac{3}{8}$ -inch diameter spaced $\frac{1}{2}$ -inch apart, center to center; the two holes alongside the feed-line-attachment holes are $\frac{1}{16}$ -inch diameter. These $\frac{1}{16}$ -inch holes accept a plastic tie to secure the feed line. I trimmed the insulator shown in Figure 2 from its original 3-inch-square shape to be more esthetic. Your artistic sense may dictate a different pattern.

Bevel all hole edges to minimize wire and feeder-insulation abrasion by the glass-epoxy material. You can do this by running a knife around each hole to remove any sharp edges.

Putting It All Together

The Squirt is simple to assemble. Once all the pieces have been fabricated, it should take no more than an hour or two to complete assembly. Begin with the center insulator. Cut each of the two element wires to a length of about 34 feet. Feed the end of one wire through the center insulator's outer hole on one side, then loop it back and twist around itself outside the insulator to secure it. Now loop it through the other two holes so that the inner end won't move from normal movement of the wire outside the insulator. Repeat the process for the other insulator/wire attachment. Separate several inches of the TV-ribbon feed-line conductors from the webbing; leave the insulation intact except for stripping about $\frac{1}{2}$ inch

from the end of each wire. Pass the TV ribbon through both $\frac{3}{8}$ -inch holes. Strip a $\frac{1}{2}$ -inch length of insulation from each dipole element, then twist each feeder wire and element lead together and solder the joints. It might be prudent also to protect the joint with some non-contaminating RTV or other sealant. Finally, loop a nylon tie through the holes alongside the feeder and tighten the tie to hold the feeder securely. A close-up of the assembled center insulator is shown in Figure 6.

Attach the end insulators to the free ends of the dipole wires by passing the wires through the insulator holes and twisting the wire ends several times to secure them.

So that the antenna/feed-line system can be tuned with the Squirt tuner, the 300- Ω feed line needs to be about 45 feet long. If you use a different tuner, you may have to make the feed line longer or shorter to be within that tuner's impedance-adjustment range.

Tuner Assembly

This tuner (see Figures 7 and 8) is about as simple as you can get. It's a basic series-tuned resonant circuit link-coupled to a coaxial feed line. At C1, I use a 20 to 200-pF mica compression trimmer acquired at a hamfest (you *do* buy parts at hamfests, don't you?), although almost any small variable capaci-



Figure 6—View of an assembled center insulator fashioned from a 3×3-inch piece of PC board from which all the foil has been removed.

tor of this value should serve. The inductor, L1, consists of 50 turns of enameled wire wound on a T68-2 iron-core toroidal form. An air-wound coil would do as well, although it would be physically much larger. Figure 8 shows the tuner built on an open chassis made of PC board. My prototype uses several PC-board scraps: a 2×3-inch piece for the base plate, two 1½×1½-inch pieces for each end plate (refer to Figure 3). A ½-inch square piece of PC board (visible just beneath the capacitor in Figure 8) is glued to the base plate to serve as an insulated tie point for the connection between the toroid (L1) and tuning capacitor (C1). The tuner end plates are soldered to the base plate to hold a pair of five-way binding posts and a BNC connector at opposite ends. L1 and C1 float above electrical ground, connected to the TV ribbon. One end of L1's secondary (or link) is grounded at the base plate and the coax-cable shield. The hot end of L1's secondary winding is soldered to the coax-connector's center conductor.

Tuner Testing

C1 tunes sharply, so it's a good idea to check just how it tunes before you attach the tuner to an antenna. You can simulate the antenna by connecting a 10-Ω resistor across the binding posts. If you use an antenna analyzer as the signal source, a ¼-W resistor such as the RadioShack 271-1301 is suitable. But if you use your QRP transmitter, you need a total resistance of 8 to 10 Ω that will dissipate your QRP rig's output, assuming here it's 5 W or less. Four RadioShack 271-151 resistors (two series-connected pairs of two parallel-connected resistors) provide a satisfactory load if you don't transmit for extended periods. Or, you can make up your own resistor arrangement to deliver the proper load. Adjust C1 with an insulated tuning tool to achieve an SWR below 1.5:1.

Once the tuner operation is verified

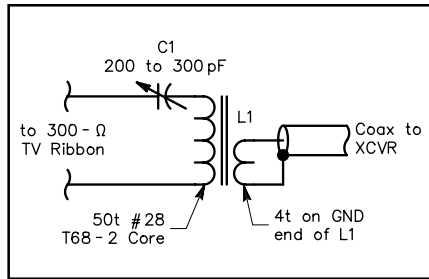

Figure 7—Schematic of the Squirt antenna tuner. See the accompanying Parts List.



Figure 8—This Squirt tuner prototype uses a 2×3-inch piece of PC board for the base plate, two 1½×1½-inch pieces for end plates and a ½-inch square piece as a tie point for the toroid and tuning capacitor.

Parts List

Squirt Antenna

Numbers in parentheses refer to vendors presented at the end of the list.

- 1—3×3-inch piece of ¼-inch-thick glass-epoxy PC board for the center insulator (1)
- 2—1½×1½-inch pieces of PC board for the end insulators (1)
- 1—1½×1¾-inch piece of PC board for the feed-line connector (1)
- 2—34-foot lengths of #20 (or larger) insulated hookup wire (2)
- 1—6-inch length of #16 (or larger bare) copper wire; scrounge scraps from your local electrician.
- 1—45-foot length of 300-Ω TV ribbon line (2)

Squirt Tuner

- 1—2×3-inch piece of PC board for base plate (1)
- 2—1½-inch-square pieces of PC board for end plates (1)
- 1—½-inch-square piece of PC board for the tie point (1)
- 1—200- to 300-pF (maximum) mica compression trimmer (3)
- 1—T68-2 toroid core (3)
- 2—Five-way binding posts (2)
- 1—55-inch length of #26 or 28 enameled wire (2 and 3)

Note: You can use ⅜-inch-thick clear Plexiglas for the Squirt's end and center insulators. Commonly used as a replacement for window glass, Plexiglas scraps can be obtained at low cost from hardware stores that repair windows.

Vendors

1. HSC Electronic Supply, 3500 Ryder St, Santa Clara, CA 95051; tel 408-732-1573, www.halted.com
2. Local RadioShack outlets or www.RadioShack.com
3. Dan's Small Parts and Kits, Box 3634, Missoula, MT 59806-3634; tel 406-258-2782; www.fix.net/~jparker/dans.html

using the dummy antenna, it's ready to connect to the Squirt. Tuning there will be similarly sharp, and a 2:1 SWR bandwidth of about 40 kHz or so can be expected as normal.

A Multiband Bonus

Although the Squirt was conceived with 80-meter operation in mind, it can double as a multiband antenna as well. The simple Squirt tuner is designed to match the antenna only on 80 meters. However, a good general-purpose balanced tuner such as an old Johnson Matchbox or one of the currently popular Z-match tuners (such as an Emtech ZM-2) will give good results with the Squirt on any HF band. The Squirt prototype was recently pressed into service at N2CX on 80, 40, 30, 20 and 15 meters for several months. It worked equally as well as a similar antenna fed with ladder line. Although no extensive comparative

tests were done, the Squirt has delivered QRP CW contacts from coast to coast on 40, 20 and 15 meters and covers the East Coast during evening hours on 80meters.

Build one! I'm sure you'll have fun building and using the Squirt!

Notes

¹Dave Benson, NN1G, and George Heron, N2APB, "The Warbler—A Simple PSK31 Transceiver for 80 Meters," *QST*, Mar 2001, pp 37-41.

²R. Dean Straw, N6BV, *The ARRL Antenna Book* (Newington: ARRL, 1997, 18th ed), pp 5-9 to 5-11.

³www.alphalink.com.au/~parker/nodoc97.htm; www.home.global.co.za/~tdamatta/loops.html

⁴home.earthlink.net/~mwattcpa/antennas.html

⁵Full-size templates are contained in SQUIRT.ZIP available from www.arrl.org/files/qst-binaries/.

You can contact Joe Everhart, N2CX, at 214 New Jersey Rd, Brooklawn, NJ 08030; n2cx@arrl.net.

Photos by the author



[HOME](#)[Sound Files](#)[Photos](#)**80M YAGI**[Intro](#)[Design and Modeling](#)[Coil Design](#)[Band Switching](#)[Mechanical](#)[Tuning](#)[Performance](#)[RX Flag](#)[Modeling](#)[Weather at VE6WZ](#)[Log Lookup](#)[Guest book](#)[Rate This Site](#)

80m & 40m DUAL BAND HOME BREW 2 EL SHORT BOOM YAGI

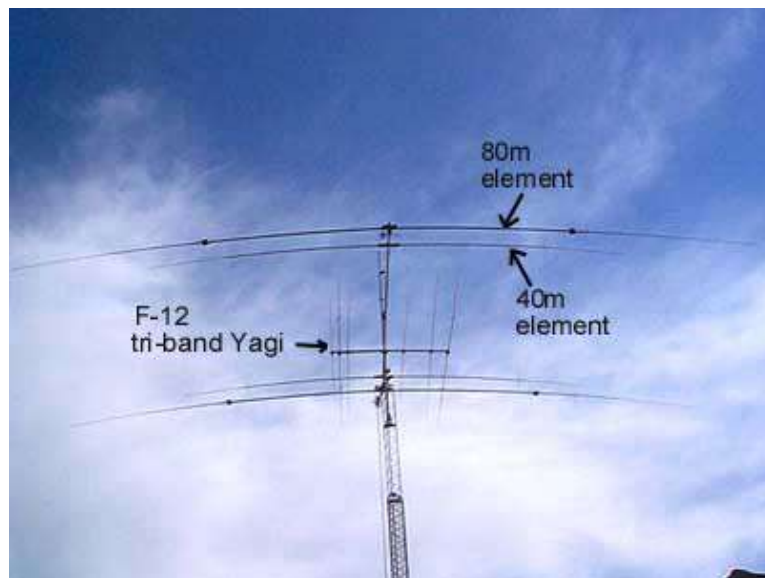

Follow the links at the left to see various pages of design and construction details. ([Click to see a full size photo of the Yagi](#))

The VE6WZ QTH is a small city lot, so achieving gain on 80m has been difficult. A vertical 4 sq. wire array was considered but would have been a compromise design because of the crank-up tower and limited space. The surrounding ground clutter and variable terrain would have made vertical performance questionable. Good DX results have been experienced using the Force-12, EF-180B, 80m rotatable dipole at 100' so it was decided to design a 2 el 80m yagi around similar elements. (F-12 markets such yagis). The VE6WZ yagi design uses high Q "mostly air core" loading coils instead of the linear loading on the 68' elements. Because of dimensional constraints at the VE6WZ city QTH, a 28' short boom reflector design was built with the 2 el 40m yagi sharing the same boom.

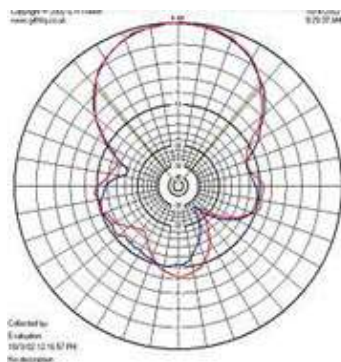

Above: Field measured azimuth plot of the Yagi on 3.8 and 3.793 MHz.

80m 2 el Yagi specifications

| | |
|--|--|
| Max F/B: | 20 dB peak (10 dB within SWR bandwidth) |
| Max gain: | 8.95 dBi (at 100', 33 deg ele. angle) |
| 2:1 SWR bandwidth: | 26 kHz (with switching 55 kHz) 3810-3760, 3550-3500. |
| Feedpoint impedance: | 15-20 ohms (hairpin match) |
| Longest element: | 66' |
| Boom : | 28' (2-1/2" X .125) Trussed |
| Weight of 80m only: | 170 lbs |
| Weight total with 40m elements: | 210 lbs |
| Estimated windload: | 13 sq. feet |

Working DX is not proof of good performance, however in the first 7 months of the 2002-3 winter season from Sept.1 to Mar.31 at VE6WZ 112 DXCC countries were worked on [80m](#), and 187 were worked on [40m](#).

Listen to the directivity of the Yagi on 80m: In this QSO with Jose, F5JD at first the Yagi was pointed at 90 deg. with very poor copy. Part way through the recording the beam is rotated to direct path at about 40 deg. and the copy is Q-5. This IS NOT a F/B test...the beam is only rotated about 50 deg. Click here and your sound player should play this .mp3 file: [F5JD_80m-03-10-12.mp3](#)

More sound recordings can be heard on the [Sound File Page](#).

Compromised performance issues (80m):

This Yagi is almost ½ full size on 80m and is a great DX performer. It has about 1 dB less gain but shows *better* F/B than a design using full size elements ([see here](#)). The small size makes it feasible to install in many situations where a full size monster would not be possible.....however some performance and operational issues arise:

- 1.) This would NOT be a great contest antenna because of the *very narrow bandwidth* and requirement to use switching to move around the band. The bandwidth could be expanded by retuning the reflector to sacrifice some gain, but some switching would still be required.
- 2.) The large coils are susceptible to inductance change when covered with snow, ice or frost. In severe cases this can render the Yagi unusable.
- 3.) Because of the narrow bandwidth and tight coupling of the elements the SWR will "swing" during windy conditions as the elements move.
- 4.) The narrow bandwidth and close coupling of the elements makes tuning critical. Great care and effort must be taken to adjust the elements for best performance. On the tower, field testing will almost certainly be required to get the tuning right. **WARNING...This is not a "plug-and-play" design.** If you build this design be prepared to spend much time tuning the elements for optimum performance.

[\(see here for comparison plots to a full size design\)](#)

WHY INDUCTOR LOADING ??



VE6WZ displays one of the 80m loading coils.

The Cushcraft "shorty-forty" experience.....

The Cushcraft XM-240, 2 el 40m yagi has been used at VE6WZ for 3 years. It has 43' inductor loaded elements mounted on a 22' boom. The loading coils are 68 turns of 12 ga. wire close-wound on a small diameter (3/4 inch) fiberglass form. Other sources have indicated a coil loss of around 3 ohms, and software calculations indicate a loss of up to 8 ohms !! ([see photo of the Cushcraft coil](#)). The coils are placed about 61 % out from the center along the element half length. The split element is fed directly with 50 ohm coax through a 1:1 balun. In spite of these poorly designed lossy coils, this yagi is a proven performer. The thesis is that an 80m design using well designed high Q coils should perform well.

The Force 12 linear-loaded 80m dipole experience.....

The F-12 80m dipole (EF-180B) is a 68' long, linear loaded element and has performed well at VE6WZ for two years. The linear load wires extend from the mid-point of the half element inward toward the element center. The wires are aluminum clad 12 gauge steel wire. The split element is fed with 50 ohm coax in combination with a "helical hairpin" to match the 18 ohm feedpoint. MININEC was used to model an 80m dipole using 68' elements and lumped inductance (coils) at 50 % from center. The feedpoint impedance is calculated at around 32 ohms. This is almost double the 18 ohms realized when using linear loading where the wires come in toward the feedpoint. Others have explained that this low impedance is because the "effective" load point is moved inward toward the center due to the loading wires running inward along the element. A low feedpoint impedance will tend to decrease efficiency. Tests on the tower support the 32-ohm feedpoint using low loss (high Q) coils. The 2el yagi design using 18 ohm linear load elements would end up with around a 10 ohm feedpoint !!!! due to mutual coupling. This could greatly degrade efficiency. Modeling the 2 el inductor loaded design yields a reasonable 16-20 ohm feedpoint. The total wire length used in the coils is much less than that needed for linear loading, and the ¼ " copper tubing used for the high Q coils has less resistance than the 12 gauge AL clad wire. The element connection points can introduce further resistive losses and these are minimized at the coil-element connections by implementing electrical redundancy.

[NEXT.....Design and modeling](#)

Below...the Yagi at 100' at sunrise.

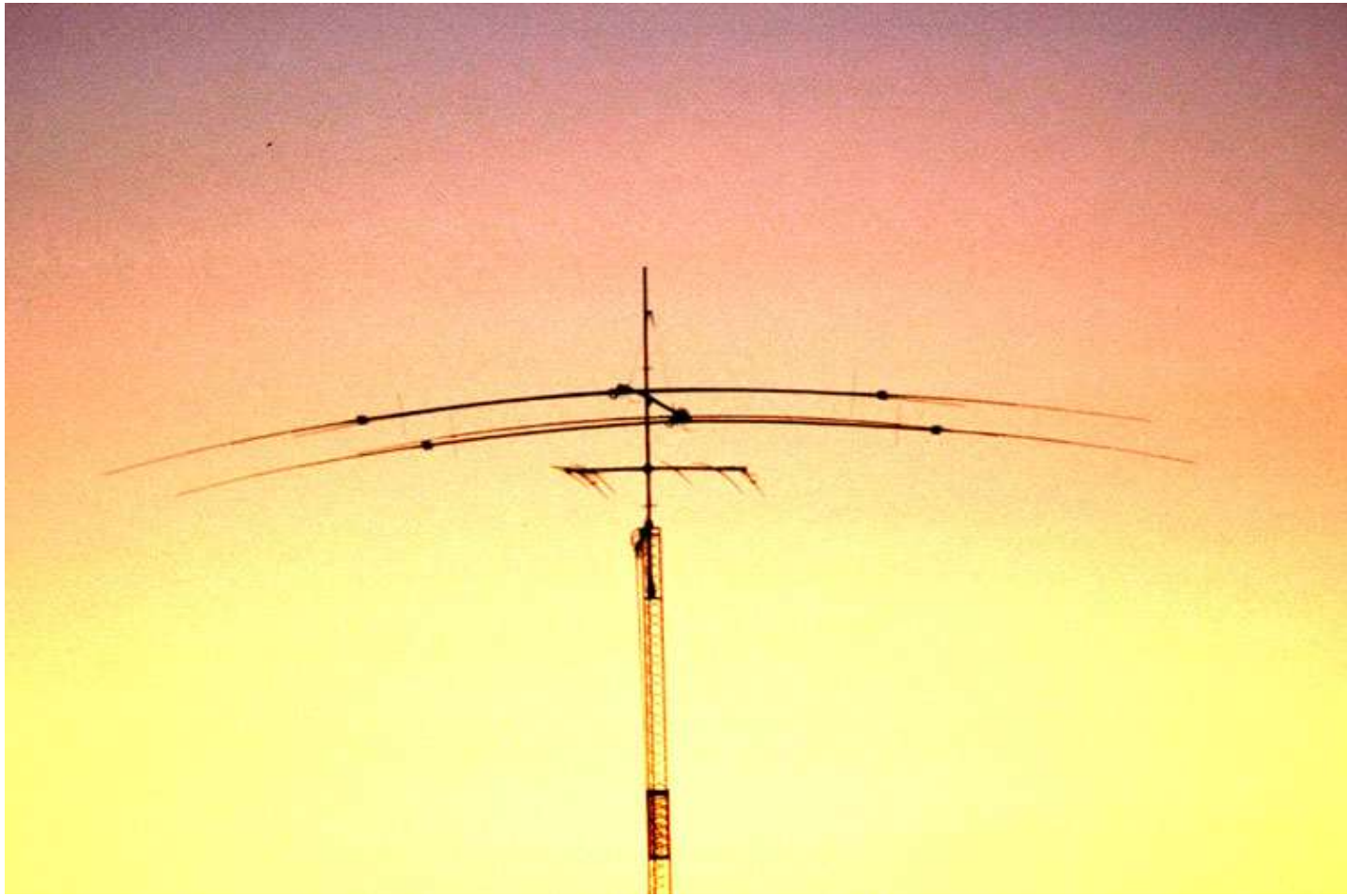

13883

A SHORT DIPOLE FOR 80m

4S7NR

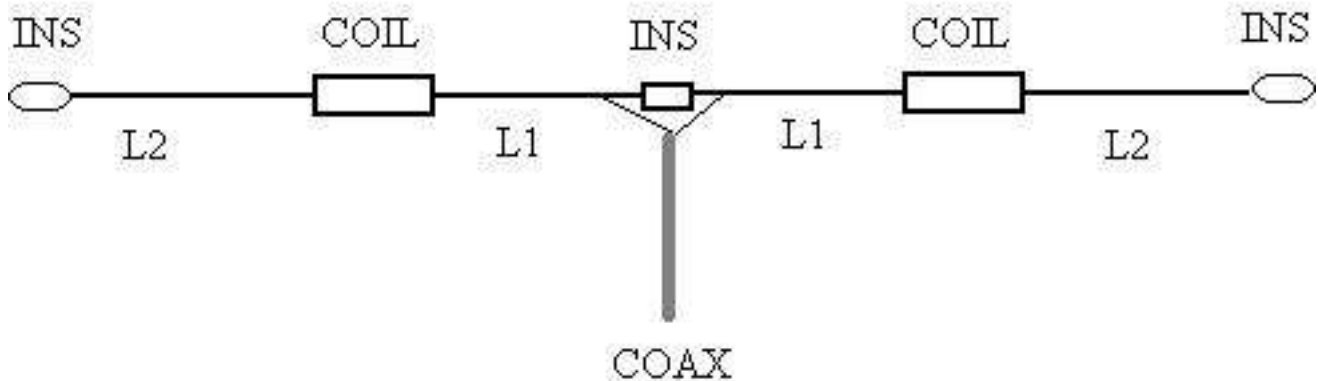

The antenna above has been described by Nadisha, 4S7NR and may be of interest to anyone wishing to get on 80M (3.5MHz) that have limited space available.

L1 is 12 feet. L2 also is 12 feet and the overall length is 48 feet.

The two loading coils are described as 67.83uH and can consist of 104 turns of insulated wire, wound over 3.5 inches. The coil diameter is not stated however. Maybe it will be a case for experimentation here.

I have a file, a dipole for 20M ([Click to view](#)) which also is a loaded dipole and works well.

It would be interesting to try loaded dipoles for other bands. I will have a try at one for 40M soon.

if you have any ideas on such dipoles or experiences with them, let me know.

(Type a title for your page here)

[Back to the first page](#)

Harry's Homebrew Homepage

[Start Pages](#)

[Projects](#)

[Reference](#)

Welcome to the "new look" homepages. Above are your subject areas, below left is the file menu and below right you will see the project file selected from the left menu. **NEW** Latest addition is [DIY IF Cans for Valves](#) 

Start menu

[Sommarstuga till salu](#)

[Start Page](#)

[Jag söker jobb](#) **UPDATED**

[Messageboard](#)

[Project kits](#)

[Links/Suppliers](#)

[Publish/Copying](#)

[Homepage info](#)

[My wife and me](#)

[Faq + Fasq](#)

[E-Mail me ??](#) **OLD**

[What's new](#) **UPDATED**



Harry Lythall
SM0VPO/G4VVJ
Updated 23rd July 2004



Technical questions? Visit the [Messageboard](#).

Welcome to Harry's Homebrew Homepages; a resource for radio, hamradio and electronics in general. I hope you have fun with my homepages, regards from Harry - SM0VPO, (Lunda), Sweden.

Sites Summary

Homebrew Projects are located at:

<http://w1.859.telia.com/~u85920178/> Unlimited bandwidth, Full site, No advertising, SWE

Visitors Circuits are located at:

<http://hem.spray.se/lythall/> Selected visitors submitted circuits - SWE

A small PDF library is located at:

<http://hem.passagen.se/sm0vpo/> Unlimited bandwidth, Full site, SWE



= Photograph illustrations included with the project.



= I have recently updated this project (Obvious, really!!!)



= Recently added (no timeframe - I'm quite informal)



= Not new (but I want it to be noticed by someone)



= The picture file is missing - please [let me know](#).

Here you can [e-mail Harry](#), but if it is a technical question then **please** be so kind and use the [MessageBoard](#). Thank you.

AMATEUR RADIO BOATANCHORS WEB RING

[Join BA Ring](#)

This [BOATANCHORS Webring](#) site is owned by Harry Lythall. Want to join the [BOATANCHORS Webring?](#)

[Next BA Site](#)

[\[Prev\]](#) [\[Next\]](#) [\[Skip Next\]](#) [\[Random\]](#) [\[Next 5\]](#) [\[List Sites\]](#)

Visitors since 01st Jan 2003: **Fc** 261291 (186,000 during 2003).
[FastCounter by bCentral](#)

Liked my site? Then please vote for it below. Thank you - Harry



HAM RADIO **The W5WW Top Ham Sites List**
ON AIR **Cast Your Vote** **On-Line Since 1997** **21,250.00**
[W5WW's Top Ham Sites List](#)



Promote Responsible Net Commerce: Fight Spam!

[Boycott Internet Spam!](#)



"Taylor Space Miser 80m antenna"

Roger Harrison (after James Taylor W2OZH)

Published: "Australian Electronics Monthly" magazine, September 1987

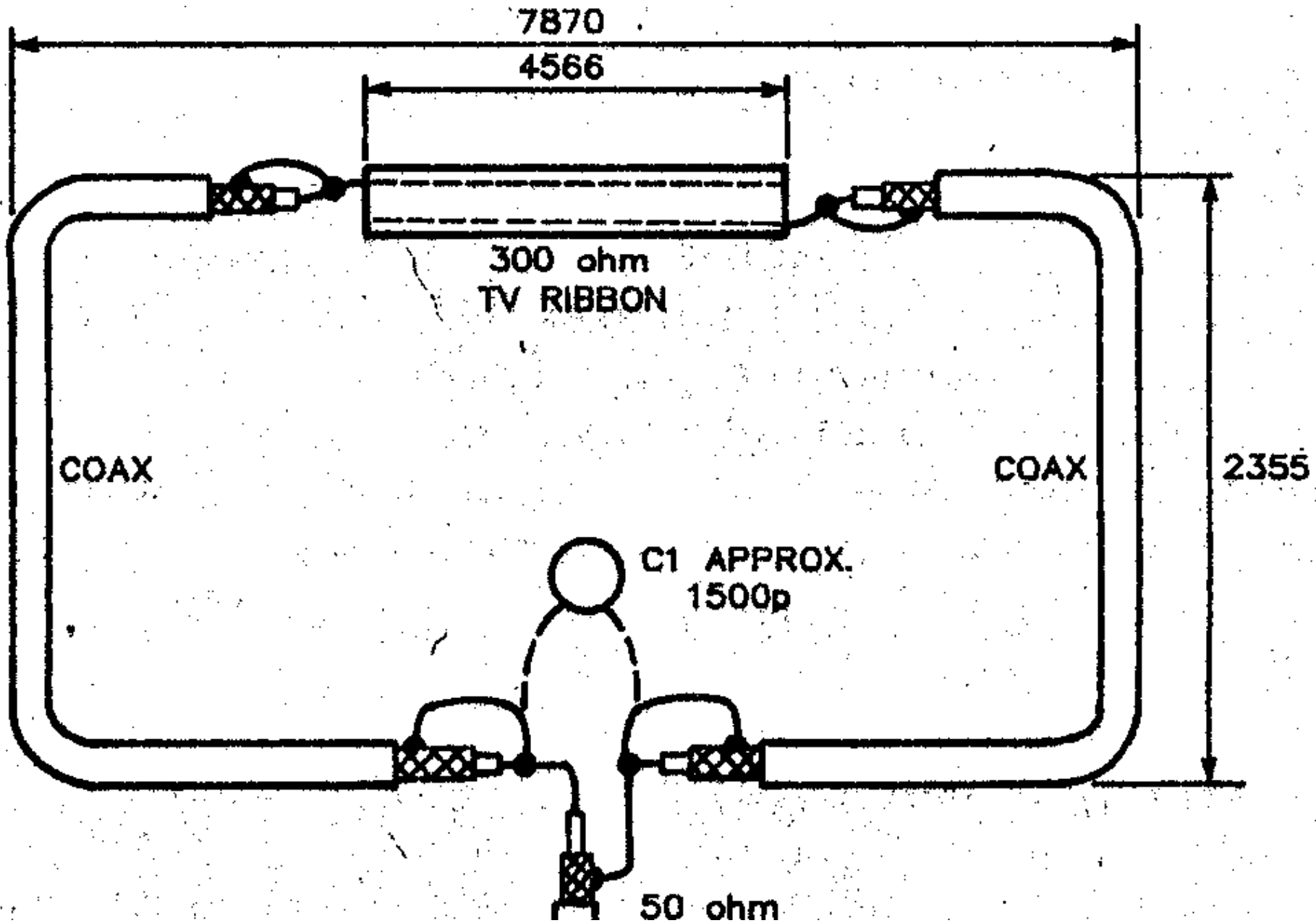
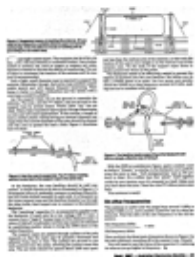

Figure 1. The general form and dimensions of the antenna. Now you can see why it's called the "space miser"!

PLEASE NOTE:

Copyright 1987 Roger Harrison VK2ZRH. Reproduced with permission. This work is not to be mirrored or otherwise reproduced by electronic means without permission of the author.

Among other ways to contact Roger Harrison, you can also do so through the author this web page, at prellis@pcug.org.au]



(January 2004) This antenna has been given new life in Canberra's Amateur Radio circles through the efforts of Tony Bennett VK1TB. Please look back for Space Miser 80m dimensions that he is developing for a "town-house roof-space".

"Here are the results with my antenna mounted in the ceiling.

Taylor Loop 80M antenna RG-213 or other 10mm co-ax.

8.120M f=3.854MHz

9.370M f=3.580MHz

9.640M f=3.531MHz

300R TV ribbon 4.65M

Bandwith at SWR=1.5: 3.59 - 3.53 for 9.370M co-ax."

Tony's loop is tilted because it follows the pitched roof of his town-house. Note: There is no aluminium-foil lining in his roof.

I also repeat here the text of an email message I received from Roger Harrison.

Hi Peter,

Thank your for the email.

I am happy for the Space Miser antenna and my article to be given a "new lease of life."

However, the proprietaries should be observed.

The Copyright Act 1968 governs use of the article. Any "work" printed, published or produced by some means is automatically copyright. No registration is required. Copyright can be sold or licensed by the creator of a work.

Although Australian Electronics Monthly is no longer published, I have retained copyright in all my "works" published in AEM (and, incidentally, a lot of other material). Similarly, I have retained copyright in all articles authored by me and published in Electronics Today.

Hence, I hold the copyright to the Space Miser antenna article published in September 1987 AEM.

However, I am happy to give you permission to reproduce the article on your website, as-published (ie. scanned pages reproduced as images), with the proviso that you add this note:

Copyright 1987 Roger Harrison VK2ZRH. Reproduced with permission. This work is not to be mirrored or otherwise reproduced by electronic means without permission of the author.

With that, the proprietaries are observed. Good luck experimenting with the antenna. I built one and mounted it on the outside back wall of our (then) office in Balmain - which overlooked a rear balcony. Nothing flash, but it did the job remarkably well.

73, Roger Harrison VK2ZRH

"Taylor" Space Miser 80m antenna

Roger Harrison (after James Taylor W2OZH)

Published: "Australian Electronics Monthly" magazine, September 1987



Love My Loop!

*A Small Loop Antenna
for Forty Meters*

By Ben Smith, W4KSY

I promised Jack Stone, Publisher of *antenneX*, if the short loop worked as well as my phased verticals on forty meters, I would write an article. I didn't promise a GOOD article because I am no writer, but it is a GOOD antenna. It does perform as well as my phased verticals. I am satisfied the effort in building this test model was worthwhile. Here is an attempt to tell you about my experiences, including mistakes. It was challenging and fun. Perhaps this will spur you into taking on the endeavor of building a loop.

Time flew, and it certainly renewed my interest in Ham Radio. There is nothing like a new antenna for a conversation piece. You get extra bragging rights when you build it yourself. (My friends hate me!) If you do bite the bullet and build one, it is hoped you will save frustration, time, and money. If you don't build it you will have a good time thinking about what a nut this guy must be! So, read on!

THE LOOP BOOK

I clicked on an *antenneX* link and read some of the free stuff. I wanted to know more about "shortened loops," and bought *The Loop Book* found in the [Shopping Shack](#) on this web site. After reading, or rather, "Screening," the book, the decision was made to build a short loop. I read about the "Special Capacitor" requirement—the need for welded construction, and of course, the capacitor has to be controlled remotely. I did a little research and found that suitable vacuum capacitors cost a lot of money. I wasn't going to invest any more than I had to in order to see how well one of these Shortened Loops worked. A stepper motor and control would cost a hundred bucks plus the cost of the capacitor. ("A steel shaft in the capacitor inserts too much loss!!!!") Hmmmm!

CAPACITOR CAPER

I am a creature of habit. I only work in a small portion of each band most of the time. For an eXperimental antenna, I could use a trimmer capacitor. I don't need to go from one end of the band to the other. Servo, and/or stepper motors and remote controls are not my cup of tea. The capacitor has to withstand high voltage and current, be efficient, and adjustable. I ended up building a capacitor out of a one inch piece of copper tubing sliding over a piece of half inch copper tubing that had an insulator separating the tube into two pieces. The separator is made of acrylic tubing inserted a little off center. The spacing for the two tubes was facilitated by making two acrylic washers, or bushings, to fit in the end of the one inch pipe with half inch holes so it would slide over the smaller tubing. *Voila!* A concentric or *trombone* capacitor!



I had a drill press, the plastics store is three miles away, Home Depot is four miles away, and I had a few bucks in my pocket. I bought the tubing (one inch copper tubing costs a little over a dollar a foot), took my treasure home and the fun began. But, the hole saws on hand were not suitable. Three hole saws were purchased, one was a mistake, (a little over eleven dollars wasted!) and the air soon was filled with the aroma of burning plastic—cough, cough! Acrylic melts! Slow and easy are the watchwords. Now how does one secure three eighths of an inch acrylic washer in copper tubing? Drill some holes through the edge of the tubing and into the washer which is epoxied in place and screw in some little nylon screws, also imbedded with a little epoxy. One must remember to have everything working before you glue and screw.

I found some acrylic rod that fits into the smaller copper tubing. I pushed one piece of the half inch tubing over the rod and then pushed in the other piece, leaving about a half inch of space in the middle. I used some epoxy on the rod before assembling the "inner plate." Then, for good measure, a center punch was used topeen the tubing in a few places to make sure that it was going to stay together. Glue is good, but mechanical means is better. I found a formula for capacitance somewhere and estimated I would have a fifty pF capacitor. It turned out to be forty-four picofarads. Which means that only twenty-two of it is useable, because it is used as a split stator capacitor. No wipers, no contact resistance. Efficient air dielectric with quarter inch spacing. *Ain't dat sumpin!*

GREAT MINDS?

A little shy of C for my design. *My design?* I took the forty foot job (forty feet in circumference, a little over sixteen feet in diameter) from *The Loop Book*. I thought I had created something when I built that capacitor. Well, don't you know, the very next issue of *antenneX* had a trombone capacitor in it!!!! However, I had an air dielectric, which is nicer, neater and more efficient than plastic tape—but, on the other hand, the guy didn't have to have a drill press and access to acrylic, nylon screws, epoxy, etc. If I remember properly my capacitor was about forty-five inches long. So you get approximately one pF an inch for one inch tubing over half inch tubing. You had better do your own numbers though if you are going to take on one of these things because I am not an engineer. Enough of the capacitor.

BUILD THE LOOP

So get out the butane torch, flux, emery cloth, tubing cutter, shine and clean tools, for three quarter inch tubing—eight pieces of three quarter inch copper tubing (I used thin wall...another mistake.) I Should have used the thick wall stuff and one inch tubing. This thing looks and feels flimsy when you try to pick it up and get it in the air. Supports could be made from wood and acrylic insulators, but why go to the trouble if it will hang together long enough for testing??? No more mechanical work than necessary is my motto. Besides the elbows I had to get a couple of tees, some reducers from three quarter to half inch

tubing. Why the reducers? To mount the capacitor on top and, parallel to the topmost member of the loop. Also, the top member of the three quarter inch tubing has to be broken and spaced in the center with another piece of acrylic rod. I had some plastic milk crates which served as supports for the loop while it was under construction and also testing after it was built.

[CLICK TO LOAD PICTURE OF LOOP ON CRATES](#)

PLUMBING SPECIAL

Now, here was the easy part, a plumbing special. Be sure to get everything clean and shiny. Where the tubing goes into the elbow, do a good job on the outside of the tubing and the inside of the elbow. Apply a little, but uniform coating of flux on both members. Apply heat to the elbow. I was surprised to see how well it sucked up the solder. I had done a little plumbing before and it was messy. But by heating up the outside member it sure pulls in the solder and it makes a neat job. A judicious wipe (careful) while the solder is molten will get rid of any pile-up.

Holy Buckets! Here is a forty foot octagonal of copper pipe with a capacitor in the middle. It looks real different out in the backyard. My cat came out to supervise on good days. He would sit up on a milk crate and sneer and make snide meows.

FEEDING

Now how do we feed this thing? *The Loop Book* suggested three ways. Well, before we match an antenna, we have to make it resonant at the desired frequency. I have built many antennas, dipoles, coaxial, bazooka, verticals, quads, rope Yagis—so, I know all about this stuff. I got out my homebrew noise generator, took about ten turns around the bottom of the loop. I connected it, then took another ten turns and coupled it to my coaxial feedline. Then, went in the house and turned on the receiver to find the resonant frequency of the loop. I was measuring the resonant frequency of the coupling coils, the feedline, the response of the receiver, *everything except the loop*.

Okay another tack! Got out my fancy DDS VFO with digital read out and my trusty Fluke digital MM with RF probe. I just about wore out the knobs on the VFO. I was getting peaks, but none of them were where they should fall. One consistent QRG (I am a CW operator, ahem!) was 6960. Moving the capacitor didn't change the frequency, but the peak was broad. Maybe the loop was too long. I took out two members from opposite sides and sawed out a foot, then two feet. No change.

Maybe, I need a dip meter. Couldn't find one locally. Build it...? Yeah, bought some banana plugs for the coils, searched and found suitable capacitor, knob, dial, box. Then while surfing The Internet one evening, I ran across the homepage of a Ham Distributor out in the Midwest. Sent him an E-Mail and whatdya know, they had one. I Bought a dip meter.

While awaiting the delivery of the dip meter, the Publisher of *antennex* sent me an E-Mail telling me that I had received a compliment on my Over/Under Quad article published in the November 1997 issue. I sent him a reply of thanks and told him the blankety-blank loop was driving me up the wall because I

could not find its resonant frequency. A few hours later, Jack sent me an E-Mail saying that the old maestro of loops, K5CNF, Richard Morrow; said I wouldn't find it by the methods I was using. I would need to put in a matching system and go for lowest VSWR. Now that really blew my mind!

So the Dip Meter arrived. Hot Dawg! I decided to use the tapped capacitor method of feed as outlined in *The Loop Book*. I went down to the hardware store, bought some quarter inch copper tubing, wrapped it in plastic tape, flattened one end, drilled a hole in it, then drilled a hole in the loop, secured that end with a self tapper. After I found the proper place for the tap, the tubing could be soldered to the loop—how clever! I taped the quarter inch stuff to the loop and mounted a coaxial connector on the loop by soldering on a strap. I connected the other end of the quarter inch tubing to the center of the connector with a piece of heavy flexible wire inserted in the tubing, and then crimped and soldered.

MAKING CONNECTION

The tubing came in a twenty-one foot length. So, how far out from the connector do I go? I figured, it would be better to start long than to be short and have to splice. I used the whole thing! After drilling numerous holes, cutting, flattening and boring holes in the tubing, I was within two feet of the connector and no pay-dirt. Once or twice I would see a small drop in VSWR. But moving the tap either way, or spacing the matching section away or closer to the loop did not make the desired effect!

I bought an MFJ VSWR Analyzer—two hundred bucks !—but, great piece of equipment. Now I had the whole mess of test equipment in one box with a VSWR Meter and a Resistance Meter side by side, a signal generator with a digital readout. Alas, it told me nothing new.

GAMMA MATCH

The next trial was going to be by the pick-up loop method. One loop shown in *The Loop Book* had a pick-up loop one-fifth the size of the main loop. Okay! I need an eight foot loop to place inside my forty-footer. I had the tubing cut, elbows in place and ready to solder when a light came on. How about a *gamma match*??



Wow! Found an old ARC-5 Transmitter Capacitor. It was nicely made with good wide spacing. I measured the capacitance with my new capacitance meter. It was 144 pF max. I mounted it on a piece of acrylic sheet, fastened the sheet to the loop with a couple of straps, recovered the remains of the quarter inch tubing and went to work. BY GOLLY it worked. A few taps up and down, pulling the small tubing away from the larger one, shoving it back and forth, and adjusted for resonance at the desired frequency with my highly efficient, and beautiful homebrew capacitor. Inside of five minutes after installation, I had an honest-to-heavens one-to-one match, with 50 ohms indicating on my shiny new analyzer at 7020 kHz!

I pulled off the analyzer, connected the feedline, ran in the house, plugged the analyzer into the other end of the feedline and whoopy-de-do!—one to one and 50 ohms. A little "smidgin" over one to one, but it wasn't to the first calibration point. We won't quibble over One point, Oh, One to One!

SIGNALS GALORE!

Next steps: plug in to the coaxial switch. The switch facilitates connecting to an eighty meter dipole and a phased vertical array for forty. Then connect the coaxial switch to my Icom 765. A quick check to where I set the lowest VSWR-7020 KHZ. Sure enough the ICOM'S SWR meter agreed. I hear signals. Lots of signals. Spent the next couple of hours making comparisons between received signal strength on the loop and my phased verticals—aiming the verticals at the received station. The loop was two S units down most of the time relative to the verticals. On occasion the loop was as good. Most of the time the verticals were better. **But**, the loop was only supported by plastic milk crates, laying down horizontally to the earth and just one foot above it!

While making a VSWR check at reduced power (eight watts) I sent three Vee's de W4KSY. I got a call from K1LGQ. Dennis, in Nashua, New Hampshire; gave me a 599 report before he knew I was on a loop and aching for a decent report. I must admit that I went to full 100 watts when I responded to his call. Never-the-less, I was elated. I made several more contacts and received good reports compared with the received signals. W9OVY, Wally near Charleston, S. C., was most helpful in assisting with tests very early in the game.

HAUL TO VERTICAL POSITION

Somewhere along this adventure I had decided the tuning capacitor was coupling to the top member of the loop, since it was only a few parallel inches away. I cut it out! Later I replaced it with an acrylic rod. This will be a great insulator to use to support the antenna! Ho!

Next day I was out in the backyard with slingshot, line, pulley, etc., etc. Got a line, with pulley attached, over a limb and hauled the loop up into a vertical position. No mean feat, single-handed. That thing sure is wobbly with no extra support. (Note to me: NEXT TIME: USE ONE INCH TUBING FOR A FORTY FOOT LOOP, or heaven-forbid, use insulated wooden supports.) Got out my trusty Analyzer, retuned to one-to-one quickly, then went inside and had a ball. Numerous contacts were made with good reports.



EARLY COMPARISONS

Summary: In most cases the loop was as good as, or superior to the phased verticals at distances out to about 800 to 1000 miles. Then the verticals seemed to take over. There were times when, even with long haul DX, the loop was better by an S Unit or two. Remember, I was aiming my phased verticals. The pattern is broad, but worth about an S Unit for locals and sometimes three S Units for DX. The loop was fixed north and south. For the past few days November 18th to November 22 there has been deep QSB,

even in daylight hours. This afternoon a South African Station at 7010 was S5 on my phased verticals and S5 on the loop. The QSB seemed slightly more prevalent on the loop than on the verticals. Background noise was about the same. Some QRM from US Stations west of me, and in the null of the phased array, was less on the array and more on the loop, of course. Figures! I hang around 7020 kHz with keyboard, or keyer, and LOOP. Demonstrations gladly given.

ANOTHER LOOP PLANNED

OKAY! This is Mark One! It is a good antenna. The performance is better than I expected. Therefore: MARK TWO is in the works. I have a new acquisition. I bit the bullet and bought a 5 to 5000 pF @ 15000 Volts, Vacuum Capacitor; with gearing, motor, limit switches and positioning pot. That monster weighs eight pounds, is almost a foot in length and five inches in diameter. The capacitor lists for \$900.00! I got the whole thing Surplus for \$187.00. Did I hear someone say something about anchoring boats? At *antenneX*, Richard, K5CNF, says to be careful with vacuum capacitors. Sometimes they are unable to handle the high current produced by the loop. According to *The Loop Book*, I should be able to make a loop forty feet in circumference, sixteen feet in diameter work on 40, 80, and 160, with my vacuum capacitor, providing it will handle the current. *Here I go, again! -30-*

Send mail to webmaster@antennex.com with questions or comments about this web site.

Copyright © 1988-2000 All rights reserved worldwide - *antenneX*©

Last modified: March 02, 2001

N3FJP World Class Station & Contest Loggers

GOOD STUFF

[HOME](#)

[QSLWorks](#)

[DEDICATION](#)

[THE OP'S](#)

[WHY HAM RADIO
- WHY NOT CB?](#)

[YOUR FIRST RIG](#)

[HF AMPLIFIER
BASICS](#)

[GROUNDED
GRID BASICS](#)

[POWER SUPPLY
BASICS](#)

[WHAT NOT TO
DO AROUND HV!](#)

[REFERENCE
MATERIAL](#)

MORE GOOD STUFF

[SELECTING A
TUBE](#)

[RF INPUT
CIRCUIT](#)

[RF OUTPUT
\(TANK\) CIRCUIT](#)

[TRANSFORMER
POWER
CAPABILITIES](#)

[PARTS IS PARTS](#)

[MOSLEY CL-33
MANUAL](#)

[ROLLING YOUR
OWN -
TRANSFORMERS
AND CHOKES](#)

[POWER SUPPLY
PROJECTS](#)

[LEGAL LIMIT
AMP PROJECT](#)



WELCOME!

QSLWorks
Full Color Custom QSL Cards
(click here)

You have reached the original WB0NNI scratch built RF amplifier site. Many changes remain to be completed and will at some point in the future (probably in the dead of winter, when the beam is caked with ice and the space heater in the shack fails to break the frost off the rig) be completed. For now, however, you'll find a number of resources available for the homebrew design and construction of HF power amplifiers that employ glass triodes, tetrodes and pentodes (not that we're opposed to solid state amplifiers that have the look and and feel of a "George Forman Grill" - it's just that we're partial to equipment that looks like it might actually do something other than cook weiners at a backyard barbeque). With that said, we remain committed to our original mission of resurrecting the practical and cultural aspects of ham radio, including a glimmer of the "tongue-in-cheek" humor, fun and excitement that has, for so many years, attracted innovators of all ages to the hobby.

With the exception of our endorsement of [N3FJP's neat, easy to use Windows logging software](#), and our recently

established endeavor - [QSLWorks](#) - where we design and produce full color, custom QSL cards as a means of supporting this site, it's a "no digital zone", with absolutely no attention given the concept of political correctness. For that reason, the theory, practical experience and simple humor is entirely analog.

For those new to ham radio, a special welcome is extended to you! Here, you will find years of practical experience offered simply for the taking; the kind of experience gained by hams that fearlessly applied theory and the use of available (often scrapped) parts and supplies (with mixed success and occasionally shocking results) to the design and construction of a variety of station accessories. If you are just getting started and are looking around for equipment, we've added a new section to help you get off on the right foot. [Your First Rig](#) provides info on a number of older rigs on the market that will get you up and running with a great signal, and without breaking the bank. Once you know what you're looking for, you might check out [Associated Radio](#). They're a fine bunch of hams with a great line of new and used equipment, as well as many hard to find parts and supplies. I've personally done business with them and was very pleased with the personable service they offer. In [Parts is Parts](#), you'll find information on salvaging parts and supplies, as well as articles on a variety of ideas such as how to wind your own chokes, and creating custom meter faces. In [Reference Material](#) you'll find an assortment of resource material that will be of use if you're seriously interested in home brewing equipment and accessories. And, if you're looking for the highest quality, full color, custom QSL Cards, then check out our [QSLWorks](#)! We established the business as a way to help support this site and are currently the only QSL printer offering premium, full custom, full color QSL cards in the US. According to the feedback we've been receiving, we are also very likely one of the Best.

So, grab a fresh cup of coffee (or stick with the one you've got), sit back and enjoy. Check out the tutorials, projects, and ideas that are featured. And, if, in the process, you think of something you'd like to see added, or perhaps make a comment on the site, or even better yet want to meet any of us on the air, just drop us an e-mail at your leisure.

Best 73s - Bob WB0NNI

Associated Radio
New . Used . Parts . Supplies . Service
Outstanding Selection - Great Prices!

DXZONE.COM
The DXZone *Amateur Radio Internet Guide*

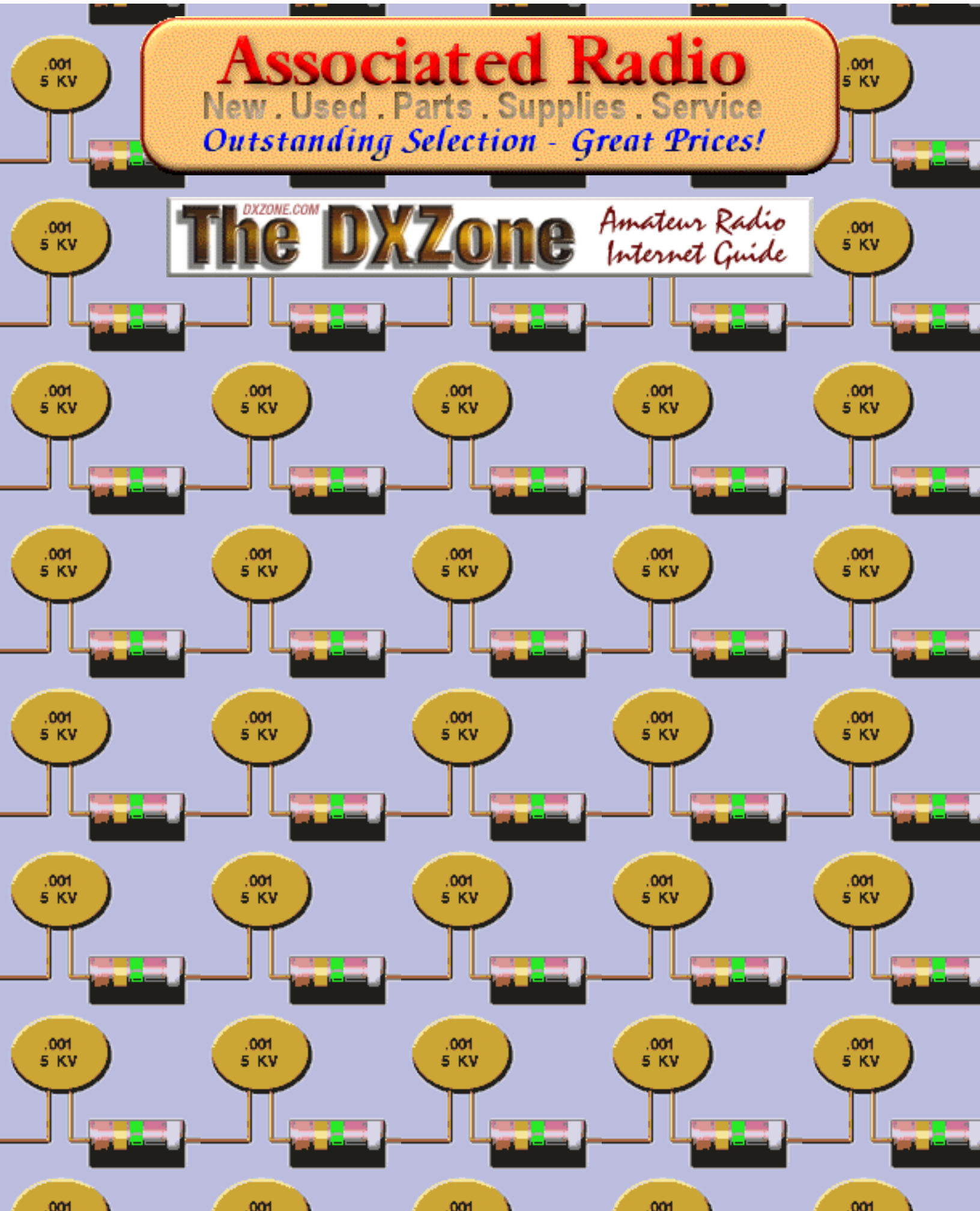

KC4HW

40 Meter Delta Loop

Site Search

Resources

[Log Search](#)

[Hamradio News](#)

[QSL Info Lookup](#)

[Discussion/Message Center](#)

[Tailgate Trader Classified Ads](#)

[Questions/Comments](#)

Linked Websites

• [CabrilloTools.Com](#)

• [DX Cluster](#)

• [N4JTP edj81racing.com](#)

• [K4PX](#)

• [AF4Z](#)

• [WB4EQS](#)

• [WT4I](#)

• **Contruccion:**

I made and put this antenna up the Friday afternoon before the ARRL RTTY Roundup (1999)! It took me about 3 hours to make and install on the tower. Most of that time seem to be used untangling the wire..hi hi

• I made the antenna 142 feet long. Use tiewraps at each of the three points to form a small loop at each end so that A 3/16" rope could be used to support the antenna. I used a center insulator that I had for a dipole- it already had a SO-239 which made it easy to attach the coax feedline. The feed point was

Total Length=142'

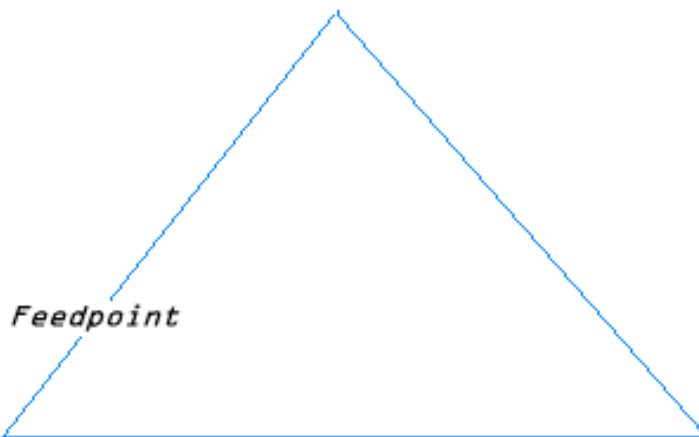

Feedpoint

Feedpoint 12' from this end

- [KC4HW](#)

12' from the bottom of one leg.

- This antenna requires a matching element of feedline made out of RG-59 (75ohm) coax. The formula for the length is a 1/4 wavelength at the operating frequency times the velocity of the RG-59. The RG-59 I had, had a polypropylene dielectric therefore the length turned out to be approximately 22 Feet. It was Easy to figure, a 1/4 wavelength at 7.050 ($234/7.050$) = 33.19' times 66 percent equal 21.9.
- Since I had the center insulator with the SO-239, I put PL-259s on each end of the matching coax and then used a bullet splicer to put the regular 52ohm coax feedline to the antenna..
- Because my mounting point was only about 42' above ground, which was insulated from the tower by a 3' fiberglass pole, I move the legs of the antenna out from the bottom of the tower approximately 25' to give a clearance under the antenna of about 7'. The legs of the antenna were secured East and West, and North and South was broadside to the antenna.
- **Results:** Actually, the antenna played better than anything that I have had previously. The SWR was flat from 7.0 to 7.1 only rising to 1.7 at 7.3. This was perfect because I wanted it to play RTTY and CW... I did find that the antenna appeared to be less effective broadside, to the North. Stations in New England were difficult to get, however, the Europeans and Western USA were answering on the first call. Also, a few days after the contest, I talked to K4HXW/Mr Tucker, he indicated that he thought the antenna was playing much better than the inverted Vee that I had previously.
- **Conclusion:** I believe that this makes a great DX antenna. Also the antenna did work on 15M. I did not try it on any other bands, but it should work well on 10 thru 40 with a tuner.. Making it a nice choice for a second radio antenna during a contest... Hopefully, I will know more about it in future contests... cu in the pile!

Added 31 Aug 2002 Update: I have put this antenna back up recently and found that the correct length was a little off on my original antenna. According to ON4UN's Low Band DXing book, the proper length for a delta loop should be 1.05 to 1.06 wavelength. The correct formula to calculate this length in feet is to divide 983.59 by the frequency in Mega Hertz ($983.59/7.150=137.56'$). I also have changed where the antenna is feed to horizontal by feeding the antenna in the middle of the bottom. This is so that I could have better effectiveness in domestic contest. After several days testing, the antenna seem to work well. Only time will tell... hi hi

K4TX

Chester, Virginia

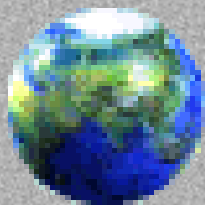

Welcome to K4TX's small bit of "Cyberspace!"

LOOK !!!

PY4VE's 2 Element 40 Meter Delta Loop Photographs!!!

CLICK HERE à [PY4VE](#)

Hi - my name is Chuck Stigberg, licensed since 1963. I've had a number of calls including:

WN4QIT - WA4QIT - KA8HLZ - KB8TA - KD4FP - NT4U - K4GE - K4TX

My primary interests are SSB, CW, Contesting, QRP, Construction & Experimenting with Wire Antennas - and yakking with my good friends on 3.868 Mhz. I look forward to meeting "you" on the bands.

[EQUIPMENT](#)



Yaesu FT-1000 MP.

Ameritron AL-1500

NYE Viking MBV-A

Kenwood TM-255 E Multimode 2 Meter Rig

● ANTENNAS

160 Meter Inverted L - Vertical portion 70 Feet - Radials (need work!)

75 Meter Horizontal Dipole @ 65 Feet

40 Meter 2 Element Parasitic Delta Loop - Switchable NE/SW - @ 60 Feet In Pine Trees

2 Meters - Diamond - Base is @ 80 Feet in Pine Tree

● DESCRIPTION OF K4TX DELTA LOOP

The Delta Loop array used at my QTH is a simple and inexpensive way to achieve substantial gain and reasonable F/B ratio. I took the idea from Dave Pietraszewski, K1WA's article in the ARRL Antenna Book when he wrote about 5 Sloping Dipoles suspended from a single tower. The sloper parasitic array he described had an "ungrounded" coax switch mounted in the tower. He used 3/8 electrical wavelength feedlines to each element. He would transmit with a single sloper & the other ones acted as reflectors. Why? Because the 3/8 wavelength feedline going to the other slopers (each being open circuited due to the ungrounded coax

switch) added inductance making the element appear 5 % longer - thus acting like a reflector.

I decided to see if it would work with a pair of equilateral loops. I already had one up, and I was disappointed with the performance. I had tried all sorts of things (i.e. switching the feedpoint to change polarization, inverted, sideways, you name it. . .to no significant avail.)

I put up the second loop - same size - spaced about 20 feet apart. It was no easy feat using my slingshot to get the ropes in the pine trees and maintaining some semblance of symmetry. I cut the feedlines (RG-8x) to the proper length. The velocity factor of the RG-8x was .81 according to the manufacturer.

Lastly - The switch. . .Ameritron's RCS-8V comes from the manufacturer with the coax ports "ungrounded." Voila! I fed the loops direct - NO quarter wave matching transformer needed!

PERFORMANCE RESULTS

Absolutely phenomenal!! On air reports confirm that this antenna is equal or better to most 2 element yagis and competitive with most 3 element yagis - albeit at the same height. And - you have to remember that "average height" of my Delta Loops are only 30 feet. The top is at 60 feet and the feed point is only about 15 or 20 feet. Typical reports? VK/ZL usually give me +20 db over S-9. I can also work them long path. Europeans typically give me the same reports or better. The front to back ratio is only about 10-15 db - but what a difference it makes to cut the European broadcast QRM when I work stations to the West! They literally go from unreadable to solid copy. Best of all is the antenna is very inexpensive and INSTANTANEOUS SWITCHING.

K4TX 2 El 40 Mtr Parasitic Switchable Array

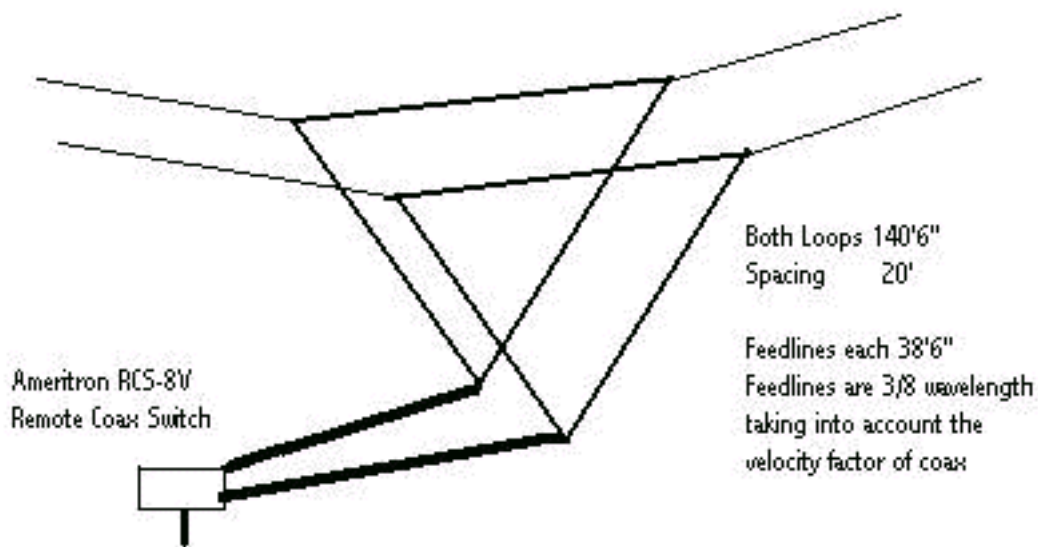

FAVORITE LINKS

[NOAA WEATHER](#)

[AC6V - The best for ham related links!](#)

[GI0AIJ - "Super Station!"](#)

[The Nerd Net](#)

[Virginia QRP Society](#)

[Sons of Confederate Veterans](#)

PERSONAL INFO

I'm 52 years old, and still enjoy the hobby a great deal. It's difficult to

fit all of my interests into my day to day living. These interests Include: Golf, Relic Hunting, American Civil War History, Writing, and a host of others too numerous to list.

I have an MBA degree, am a Vietnam vet, and work as President for a Cable TV Construction Company. I've worked for the various large CATV companies in the past, and I was even fortunate enough to begin my own cable TV system that was ultimately sold to a large company after only 3 years. That was back in late 1989. My company now provides turnkey aerial and underground construction of coax and fiber optic cable with services predominately in the Mid-Atlantic region of the US. I'm married to a beautiful wife. I have a 23 year old daughter, a 13 year old son – AND Twins were born November 17th, 2000. Sean & Shelby. . .a boy and a girl!



 [E-Mail K4TX](mailto:K4TX@delta-loop.net)

021878

The 40 meter Stealth Vertical

As published in www.antennex.com Dec. 2001

[Home](#)

[K7ZB QSL Card](#)

[A brief K7ZB history...](#)

[K7ZB activities...](#)

[160m DX Contests -
2001/2004](#)

[Jamboree On The Air
2000](#)

[A radio attempt on
Kathmandu...](#)

[An effective 10-20m DX
antenna for deed
restricted lots...](#)

**The 40 meter Stealth
Vertical**

[A Stealthy 75 meter
Antenna](#)

[HF Receiving Loop
Antenna](#)

[Other activities and
photos](#)

[Email K7ZB](#)



"You're 30dB over 9 here..." So goes the consistently fine signal reports received from around the USA and beyond - on 40 meters at the peak of Sun Spot Cycle 23. The most common antenna used in ham radio mounted over poor desert soil conductivity still performs beautifully!

This is the view of our second floor deck as seen from the closest street. The need for a 40 meter antenna that would perform well and not violate the spirit of the Home Owner's Covenants protecting the aesthetics of the neighborhood was the driving force behind the design of this vertical.

This antenna was designed to provide low angle radiation for good DX performance during the night time hours. DX on 40 meters is best when the local sun is down and this makes it convenient to use the cover of darkness to hide the size of a quarter-wave antenna. Especially one which is mounted 12 feet above ground which puts the top of the vertical at nearly 50 feet!

The basic concept is to mount a standard 1/4 wave vertical element on a swivel mount, secured to the deck railing. The mounting must be extremely secure when the antenna is in the upright position. It should also be easy for one person to put up or take down in less than 5 minutes. This design meets these criteria with excellent results.

The 40m vertical in its down position rests along the bottom of the far side deck railing. It is supported by plastic coated hangers of the type sold in hardware stores for hanging bicycles, etc, on garage walls. These hangers also make excellent supports for the antenna in the intermediate position for extending the telescoping top section and for supporting the vertical in the upright position.

Shown below is a view of the vertical with the telescoping top 5' section removed and stored in the down position. The swivel assembly has a spring-loaded locking pin which secures the base in either the upright or down positions. Putting up the antenna is simple: the top section is secured with a wing nut then the

vertical is walked up hand-over-hand into the upright position and locked in place with the pin. The hanger also stabilizes the antenna so it does not sway in light wind.

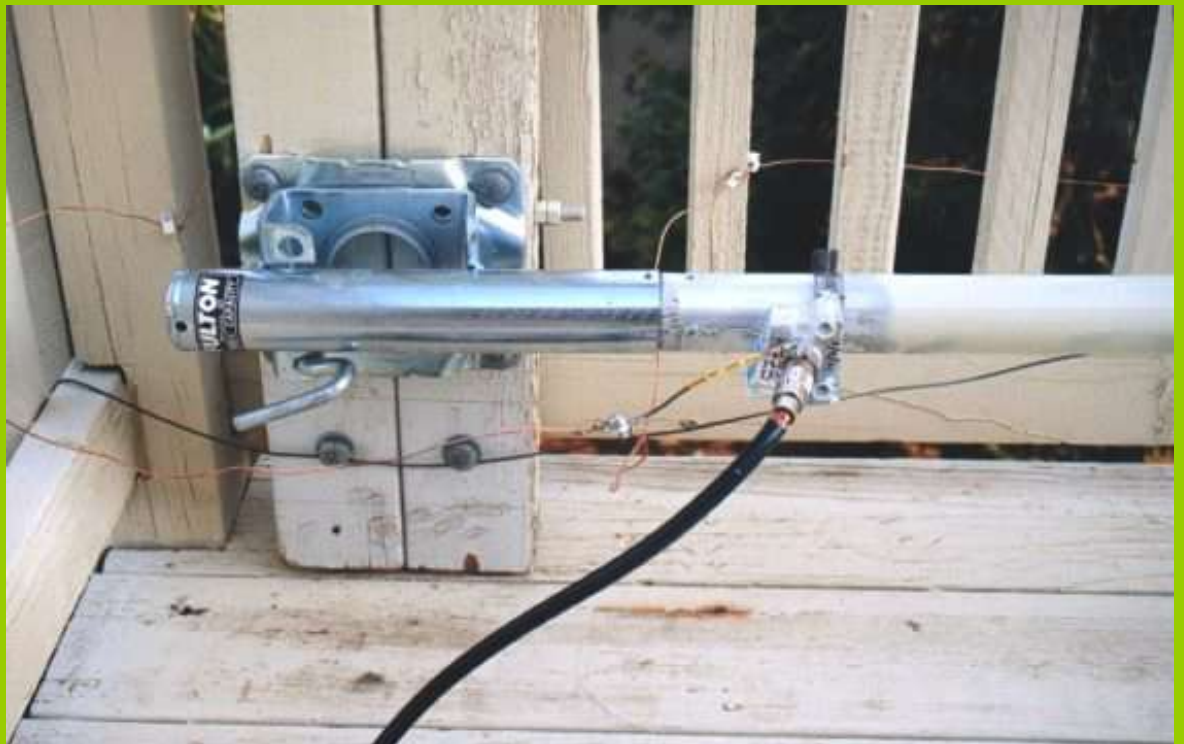

The swivel assembly I modified is a Fulton TJ503 swivel jack stand with snap ring, purchased at Walmart's. Fulton's website is available [here](#).

The swivel assembly has been modified to support the vertical base element. Its load rating is well in excess of the load imposed by the vertical. Since the 35' - 7 1/2" vertical is only intended for use during good weather conditions it is only guyed with two light guy lines to ensure that in case something did happen to the antenna while up, it will not fall across neighbor's property. In our neighborhood there are no above-ground wires for power, cable TV or telephone, so there is no possibility of a crossed-wire mishap.

The coax attachment is made through an SO-239 connector mounted on an acrylic plastic block drilled and U-clamped to the base tubing. Also visible are the two radials connected to the shield of the coax connector. The two radials are 33' long, and slope from 12 to 7 feet above ground at their end. They slope because that's the available tie point height in the yard. The radials are oriented 145 degrees apart - not quite the 180 degrees desired but close enough. The EZNEC antenna azimuth plots do show the minor skewing of the pattern due to the asymmetric radial placement, but this has little effect on its performance.

The net active dimensions (not including the length inserted into lower elements) for each element of the vertical are as follows:

Base element: 11' 5" (1 3/4" Dia. Al tubing)

2nd element: 10' 2" (1 1/4" Dia. Al tubing)

3rd element: 5' 7" (3/4" Dia. Al tubing)

4th element: 4' 11 1/2" (1/2" Dia. Al tubing)

5th element: 3' 6" (3/8" solid Al rod)

The tubing diameters were based on what I had available. Good mechanical design technique should be used in attaching each element securely into the lower one.

This antenna does bow substantially when being put up and down. This droop could be minimized by going to a higher strength alloy. The best strength-to-weight ratio for vertical tubing is probably titanium-aluminum alloy, although it costs substantially more than the material I used.

Raising and lowering 35 feet of aluminum tubing up over one's head in low light conditions leads to safety considerations. I wear a hard hat and safety glasses when raising or lowering the vertical.

A Word document is available which contains a few more construction details and EZNEC plots for this antenna. Send me an email and I will provide a copy.

Shown below is a night-time photograph of the vertical in the upright position. The stabilizing hanger is seen approximately 2' above the swivel assembly. Notice a 6 turn coax loop in the line which serves to help keep RF out of the shack - which is about 20' from the vertical. The RF exposure on 40 meters with 500 watts output is within the FCC's Maximum Permissible Exposure limits.

An advantage of verticals mounted above ground like this one is the safety aspect of proximity to RF-hot radial wires or vertical elements. Our yard is walled and the RV gate kept locked, and the access out to the deck is past my operating desk - so there is little danger of anyone's unexpected exposure to hot wires.



Here is Brian (KD7Z) looking up at the top of the vertical with Dave (AB7E) out on the deck.

Brian helped with the design concept when he directed my attention to a Hints & Kinks article in QST (May 2000, page 56) that featured the fold-down mobile-antenna mount design of KB5YA. It was this use of the swivel jack that led us to conceive its use for a deck-mounted 40m vertical design.

Dave provided EZNEC computer simulations for the vertical dimensions used here, which when implemented were right on target.

The photo below is of the vertical in daylight - up just long enough to take the picture to show how it looks at night! You can faintly make out the guy lines and one of the radials running out to the spot where I was standing to take this picture. Above the doorway on the deck is the coax feedline to the center insulator at the eave under the roof peak for the 75m antenna.



An excellent reference for understanding vertical antennas is provided by L.B. Cebik, W4RNL. Dr. Cebik is an authority on antennas and his website contains a vast amount of excellent information. The webpage specifically covering verticals is shown below.

["Verticals Without Vertigo" by L.B. Cebik, W4RNL](#)

Here's a QSO I made with A61AJ in the United Arab Emirates on 40m CW using this antenna and 100 watts. The Great Circle Bearing map below (AZ Map by Paul Burton AA6Z) shows the conditions. Gray-line propagation makes contacts like this possible and a vertical antenna can help you take advantage of it.

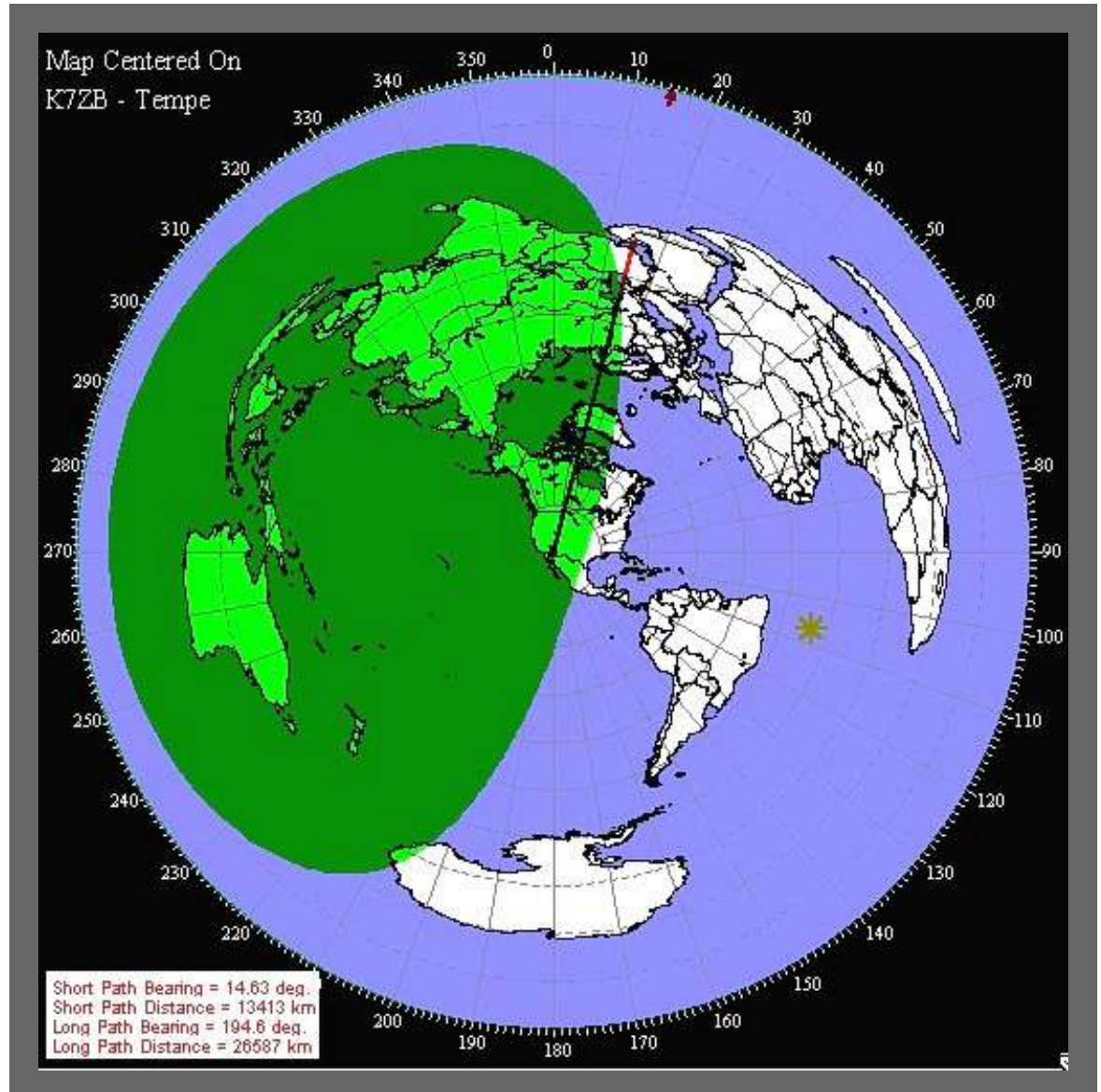

Signal path analysis:

This QSO illustrates a typical *Long Path* communications link. It is possible that the path was established with multiple hops of our signals in both directions. RF leaving my antenna would have launched at the low take-off angle associated with vertical antennas then skipped off the F2 layer of the ionosphere and returned to earth somewhere near the maximum single-hop skip distance of 4,000 km. This would place the first approximate reflection point out over saltwater on a bearing of about 195 degrees South of my QTH and in the South Pacific. The excellent conductivity properties of saltwater would allow efficient rereflection of the signal back up at a low angle and the process repeated for about 6 hops when the RF finally arrived from offshore into the United Arab Emirates. Other propagation modes like chordal hopping could have been involved as well. The enhanced propagation due to the sun's terminator made the path work with a mere 100 watts

at my end. The picture below was taken of this sunrise just minutes after the QSO.

The sunrise at the time of the A61AJ QSO...



Both 40m and 20-10m verticals are up. Note the stars still visible so early in the morning!

Shorty Forty Antenna

City dwellers and other flat dwellers know the practical difficulties they encounter when they try to put up an antenna for 40 meters. Finding space enough to accommodate 67 feet of wire is a real problem for them and most of them have to be satisfied by the inverted V. Whatever the book say, in practice the inverted V does not come up to the standard of a dipole antenna.

The Shorty Forty Antenna can be put up in the space required for a 20 meter dipole. It is a compact 40 meter dipole for limited space application by Jact Sobel W5VM. It is a center loaded antenna with a loading coil at the center. The two arms are 18 feet 6 inches long connected to the two ends of an inductor at the middle. The inductor consists of 30 turns of 12 SWG enamelled copper wire wound on 2.5 inch diameter PVC tube 5 inches long. There is six turns per inch so 30 turns will require 5 inches long. The shield of 50 ohms coaxial cable is connected to the center of the coil. The center conductor is connected to 2 or 3 turns away from the center, to a point which gives the lowest SWR. Compare this to a 67 feet dipole the saving in space is substantial.

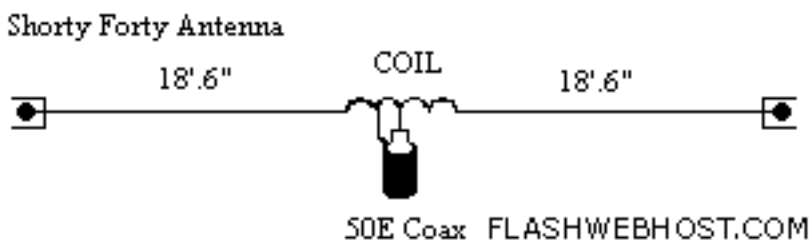



Ham Radio Operators ID Badge
Engraved with Your Name, Call Sign [Click Here](#)



Find on this site...

[Site Index](#)

- [Exams](#) Search site: Call sign search:
•[Clubs](#)
•[Hamfests](#)
•[Addresses](#)

ARRL Member Login...

Username: Password:

[Register](#)

Quick Links...

- [Join or Renew](#)
•[Catalog & Store](#)
•[ARRL Courses](#)
•[Classifieds](#)
•[Getting Started](#)

[Operating Activities](#) [Licensing](#) [News/Bulletins](#) [Services](#) [Educational](#) [Public Service](#) [Support](#) [Donate to ARRL](#) [ARRL Info](#) [Text-only/Printable](#)

The Beam/Yagi Antenna

[ARRL Technical Information Service page](#) · [TIS Menu page](#)

Additional information on this subject and related topics can be found in back issues of [QST](#) and the following:

[The ARRL Antenna Book](#)

[Physical Design of Yagi Antennas](#)

The [ARRL](#) has an extensive [catalog](#) of books and materials related to [Amateur Radio](#).

Articles

Note: Some of the following articles are in Adobe Portable Document Format (PDF) files. To view and print these files, you'll need a copy of Adobe's Acrobat Reader program. (Version 3.0 or later required). More information [here](#).

- [Simple Offset Feeding of Wire-Element Beams](#) (209,735 bytes, PDF file)

MEMBERS ONLY

QST October 1999, pp. 45-46

This approach to matching a feed line to an antenna uses the antenna itself as an impedance transformer.

- [Why A Beam Antenna?](#) (1,221,309 bytes, PDF file)

QST January 1972, pp. 36-39

Some basic antenna information for the newcomer about Yagi antennas including a tutorial on antenna gain and construction of a 15-meter beam antenna.

- [Simple Gain Antenna for the Beginner](#) (778,544 bytes, PDF file)

QST August 1981, pp. 32-35

A tutorial on the Yagi antenna with construction of a two element beam for 10-, 15-, or 20-meters.

- [The Building-Supply Yagi](#) (920,911 bytes, PDF file) **MEMBERS ONLY**

ARRL Products:
Interference/DF
[\(More\)](#)



AC Power Interference Handbook -- New

insights into the causes, effects, locating and correction of power-line and electrical interference. 2nd Edition.



Transmitter Hunting -- Radio

Direction Finding Simplified



The RSGB Guide to EMC -- Tackle

RF interference problems and understand the underlying causes.



The ARRL RFI Book -- Practical

Cures for Radio Frequency Interference.

QST March 1991, pp. 22-24

Here's a cheap, easy-to-assemble, two-element Yagi you can build for 10, 12, or 15 meters.

- [Two on 10](#) (237,149 bytes, PDF file)

QST April 1999, pp. 67-69

A two element 10-Meter beam designed for portable or permanent installation. ([Additional information](#))

- [A Two-Element Duoband Beam](#) (880,439 bytes, PDF file) **MEMBERS ONLY**

QST April 1993, pp. 36-37

Explore the 12- and 17-meter bands with this small, lightweight Yagi.

- [A 15-Meter Beam On A Budget](#) (602,286 bytes, PDF file) **MEMBERS ONLY**

QST February 1971, pp. 41-43

A two element beam made from electrician's thin wall tubing.

- [Basic Beams for 12 and 17 Meters](#) (1,494,442 bytes, PDF file) **MEMBERS ONLY**

QST August 2000, pp. 57-62

Some well-designed and easy-to-build antennas for the 12- and 17-meter bands.

- [A Three Element Lightweight Monobander for 14 MHz](#) (178,829 bytes, PDF file) **MEMBERS ONLY**

QST July 2001, pp. 28-31

A portable easy to build light weight antenna

- [A Portable 2-Element Triband Yagi](#) (257,252 bytes, PDF file)

QST November 2001, pp. 35-37

This novel wire antenna is great for permanent or portable, QRO or QRP, and old-timer or beginner operation.

- [Practical High Performance HF Log Periodic Antennas](#) (1,238,771 bytes, PDF file) **MEMBERS ONLY**

QST September 2002, pp. 31-37

The Electrical and mechanical design process for two Log Periodics that cover the HF bands from 10-30 MHz.

Note:

Contact information for suppliers mentioned in the above articles should first be confirmed using [TIS Address Database Search](#).

Bibliography (Members Only)

[ARRL Periodicals Index Search](#) - This database contains the *QST* index from 1915 to the present and the *QEX* index from 1981 to the present. For *QST* issues from 1970 to the present, and some selected articles back to 1922 (when construction articles featuring tubes began in earnest), identifying keywords have been added to the technical articles. By entering keywords (ANTENNA) or combinations of keywords (CONSTRUCTION ANTENNA VERTICAL HF) into the **Title words:** field, you may create dynamic bibliographies.

Technical article [KEYWORD list](#). [Hints for more successful searching](#)

Suggested keywords for more articles like the ones on this page are: [CONSTRUCTION HF BEAM ANTENNA](#)

Web Links:

- [K5TR](#)

A collection of antenna modeling files

- [Mini-Beam Geometry Basics](#)

There is a natural progression of the geometry of the "mini-beams" deriving from the basic yagi, which in itself owes a lot to the common dipole.

- [Stacking Yagi Antennas](#)

- [KBOYKI's Radio Zone](#)

On-line antenna designers, rooftop tower plans, gamma matches, and more

- [DXCC Country List / Beam Headings](#)

Display a current DXCC list with beam headings centered on your location.

Article Reprints:

***Note:** Reprints are available from the Technical Department Secretary, ARRL, 225 Main Street, Newington, CT 06111. Article copies must be prepaid \$3 for ARRL Members, \$5 for non-members. You may order by telephone (860-594-0200) and pay by credit card. Reprints can only be sent by mail and cannot be sent by or attached to e-mail.*

This information was prepared as a membership service by the American Radio Relay League, Inc., Technical Information Service, 225 Main St., Newington, CT 06111 (860) 594-0214. Email: tis@arrl.org (Internet). ARRL HQ is glad to provide this information on the Web free of charge as a service to League members and affiliated clubs.

If you have any questions concerning the reproduction or distribution of this material, please contact:

TIS Coordinator
American Radio Relay League
225 Main St., Newington, CT 06111
Tel: 860-594-0214 Fax: 860-594-0259
(email: tis@arrl.org)

Page last modified: 10:24 AM, 02 Jul 2003 ET

Page author: webmaster@arrl.org

Copyright © 2003, American Radio Relay League, Inc. All Rights Reserved.

NB6Zep Antenna

Basic Design: A modified 20 meter Extended Double Zep **Operating Bands:** 40 thru 10 meters (with tuner)

Dimensions: 66 feet horizontal, 5 feet vertical **Transmission Line:** Open Ladder or TV Twin Lead

Materials: Conventional low-cost wire antenna construction (see below for details)

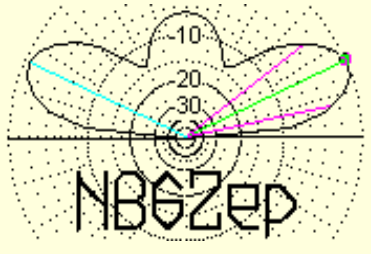

- The Super Zep is an elegant multi-band wire beam found [here](#).
- Build a wire dual band DX Dipole or Yagi antenna system [here](#).
- Instructions to add 80 meters to the NB6Zep are found [here](#).
- Instruction for the smaller NB6Zep Jr are found [here](#).
- A Space Saving 80 meter antenna is found [here](#). 

The NB6Zep antenna is a simple inexpensive wire antenna, easy to build, that will yield excellent results on all bands. Only a dipole would be easier to construct and maintain. Unlike a dipole, the NB6Zep will operate on all ham bands 40-10 meters (including the WARC bands) with no strain on the antenna tuner, transmission line or operator. When you follow the basic rules for this antenna and use good common sense construction techniques to build this antenna, you will receive reliable results as shown in the documentation I have provided here.

"I wanted a portable antenna I could throw up between trees while camping so I made the NB6Zep on your web page. To test it at home I (naturally) set it up between a tree and a old section of TV mast tied off to the field fence. It's all of 15' off the ground but is noticeably better when I A-B compare it to a G5RV at 35'. The antenna is still up proving there is nothing so permanent as temporary when it works!"

"Thanks for putting the design on the web. Easy to build and the darn thing works..." Jim Edmondson WA7KQG

I live in an area with severe antenna restrictions. Not even TV antennas are found on the houses in my neighborhood! For the last eleven years I have been operating successfully on the HF ham bands by hiding my "evil activity" in the pine and fir trees that line the back yard of my home in Beaverton, Oregon. I have experimented with many designs and techniques for low-profile wire antennas over the years and have learned what works and what does not work. I have 5 wire antennas integrated into the back yard, but the single most valuable antenna I have is the NB6Zep at 40 feet above the yard! An NEC wire modeling program is needed to keep all of my wires operating properly in the space of a typical back yard. I have spent many hours using EZNEC to model the NB6Zep antenna. The total length is optimized to fit in the space of a 40 meter half wave dipole and the feed line length is optimized for good operation when attached directly to a tuner with balanced output. A coax termination to the tuner can be used with a 4:1 balun device at the end of the balanced line. I am happy to share with you the details for building your own NB6Zep.

Basic Construction: The wire must be installed as horizontal as possible. Do not invert or "dog leg" the wire as this will impact expected performance. The wire and feed line are light enough that it can be mounted with just the two ends supported. A strong 18 AWG wire is used to make both legs of the center fed antenna. Cut each leg exactly to the same length of 38 feet. (33 feet horizontal and 5 feet to hang down vertical.) Use a heavy duty ceramic or plastic insulator for the center to connect the wire legs to the feed line. [CLICK for DETAIL](#) The modeled feed line

length was 49 feet long for open ladder line and 41 feet long for TV twin lead.

Use a medium duty ceramic or plastic insulator at both ends of the horizontal wire to serve as a tie off point for the antenna support and to support a 90 degree bend to drop the last five feet down vertically. [CLICK for DETAIL](#) Attach a medium size lead fishing weight at the end of the wire to keep gravity working for you. Use a section of nylon twine (string) to hold back the vertical wire from wrapping itself around the support mast or other objects when the wind blows. [CLICK for DETAIL](#)

Mount the NB6Zep as high as you can manage to support it. Drop the feed line down or away from the antenna at 90 degrees for as far as possible. Keep the feed line away from metal objects if possible. The line may be attached directly to the balanced line output posts of any tuner. [CLICK for DETAIL](#) If that is not possible, construct (or purchase) a 4:1 voltage balun and connect the step-up balanced side of the transformer to the twin lead and connect a short run of coax to the unbalanced side. You connect the other end of the coax to the unbalanced output connector on the tuner. This technique is useful for bringing twin lead from the outside into the shack through a window or other entry. Make a loop at the balun transformer to keep rain out of the device. [CLICK for DETAIL](#)

Basic Performance: While waiting for the rain to stop so that I could install the antenna at 40 feet, I operated for several days with it stretched between two trees at 6 feet off the ground. Good psk31 contacts were made from Oregon to the East coast with 50 watts on the 40 and 30 meter bands. (High angle radiation is very under rated on the low bands). The antenna was brought to 40 feet, supported by two light gauge steel Radio Shack masts strapped to the upper trunks of two pine trees about 70 feet apart. The antenna is broadside to the SE and NW. All of the design data from EZNEC is based on the NB6Zep at 40 feet off the ground and with no large objects or other tuned antennas in the near field. The gain of the NB6Zep is based on the maximum field from a 1/2 wave dipole at a 1/2 wave length above ground. Your performance will differ if, for example, you have dipoles, yagis or any horizontally tuned antennas in the same yard as the NB6Zep. Your results may differ if your antenna height is less than 35 or greater than 45 feet. You should consider removing other horizontal antennas as they will be mostly obsolete with the NB6Zep installed. If possible, align your NB6Zep in the direction that places lobes where they will reach the largest population of ham operators. Nulls in the antenna above 30 meters can be useful to reduce QRM and interferences sources that are picked up by the horizontal polarity of the NB6Zep.

The NB6Zep should perform well at lower heights, even down to 20 feet. The take off angle will be effected by becoming lower at heights above 40 feet and higher for lower construction. It is possible to have good operation with the legs inverted down from the center feed point, however, the diagrams provided here are not valid unless the antenna is horizontal with the ground and in a straight line.

The NB6Zep is not a "tuned" antenna and will not interact significantly with other antennas in the yard. You could construct several NB6Zeps to have selectable directivity for the bands above 30 meters.

40 and 30 meters: The NB6Zep performs like a half wave dipole, with broad, medium to high angle lobes running off the sides of the antenna. Very good for regional and for long distance skip. The antenna displays very little directivity on the low bands and is performing very well in all directions.

20 meters: On this important DX band, the NB6Zep has it's highest gain, over 3 dB. There is a sharp medium angle lobe running 90 degrees from both sides of the antenna. [CLICK for DETAIL](#) For the first few contacts on 20 meters with the NB6Zep, I reached Texas, Utah, Alaska, Korea, Japan and Argentina, all with strong reports. A good QRP contact to Japan was made on PSKHELL mode. [CLICK for DETAIL](#) The antenna produces very sharp lobes from each side, good for long distance and regional skip.

17 and 15 meters: On these bands the NB6Zep produces two broad lobes spaced 45 degrees from both sides of the antenna; each lobe has gain. This looks like a butterfly pattern when viewed from above the antenna. [CLICK for DETAIL](#) The antenna performs very well for long distance with it's low angle radiation and also has medium angle radiation for shorter skip operation.

12 and 10 meters: On these higher bands the NB6Zep produces two narrow lobes with gain, separated by 60-80 degrees from each other on both sides of the antenna in an "X" configuration. [CLICK for DETAIL](#) Two layers radiate from the antenna giving very good operation for long skip and shorter skip conditions. As on 20 meters, the NB6Zep is very directional on 10 meters.

A diagram showing the current distribution on the NB6Zep antenna system for the major bands is [FOUND HERE](#)

Construction Notes: Ceramic "egg insulators" are commonly used in wire antenna construction, but I have had

good results over the years making my own wire antenna insulators from plastic coat hangers. (Use the flexible round type purchased in stores, not the free hangers from the dry cleaners.) They are very strong, UV resistant and low-cost. Cut 3 inch sections and drill holes a 1/4 inch from the ends. Use them at other lengths for wire spacers when making a "fan dipole" or open ladder feed line.

Always solder every wire connection and then insulate connections from water seepage. Also insulate around all exposed coax braid. Use "hot melt" glue or a silicon rubber sealant like RTV. [CLICK HERE](#) to see some of the basic materials and tools I use to construct wire antennas.

You can make your own light weight balun using Iron Powder Toroid cores. The smaller T130 HF material (red) cores work fine for several hundred watts. Follow the diagrams in the ARRL handbooks. Use a hand drill to twist 20 AWG enameled wire into winding sections used in bi-filar and tri-filar transformers. Make about 12 turns onto the core for good performance. [CLICK for DETAIL](#) Wrap layers of electrical tape around the balun to protect the core from damage. (Cores are like glass and once they are cracked the core permeability is altered.)

Use medium weight nylon twine for all of your wire antenna construction and support needs. It is extremely strong and lasts forever.

The NB6Zep Story: Once upon a time, in a land far to the Northwest, there was a full sized 20 Meter Extended Double Zep antenna supported only by two majestic pine trees. The trees both stood at the very outer regions and at opposite corners in the land known as NB6Z. This span of distance allowed the EDZep to spread, although the weight of the feed line at the center could not be supported, causing a rather unsightly and disconcerting droop to be seen. Despite the odd appearance of this stately antenna, it continued to serve its' master well for many years; with many fine contacts on all bands from 40 through 10 meters. It occurred on one winter's day, that a fierce storm blew down one of the two pine trees that had supported the EDZep. This caused much anguish to the master of the land, who immediately gathered his forces to find an acceptable solution to this dilemma. Several seasons of trial and error passed, but no resolve could be made. Finally, after much calculating and re-calculating, a new design configuration was found and a new support tree was christened. Much to the delight of the master of the realm, it was found that this new design had no droop to catch ones eye. Further joy was had when the on-air performance of the new antenna was found to be just as good as the original! Overcome with joy, the master named this new design *NB6Zep*, after the land in which it resides. He further decreed that the new design be shared throughout all the land of Hamdom and with all who seek to enter the Kingdom of Ham. 🤪



"Push-button Menu of Stuff"

20m Delta Loop.

This antenna is fed for vertical polarisation, to give a low angle of radiation for DX and also a nearly omni-directional radiation pattern (broadside is the best direction by about 3 dB).

I have built two versions of this antenna; one using coax as a monoband antenna for 20m as simulated below, and the second as presently used with 450 Ohm slotted ladder-line feeder for multiband use (20 and 15m).

In the monoband application, the impedance at resonance on 14.2 MHz of about 100 Ohms is transformed by a quarter wavelength of 75 Ohm cable (3.5m long) to give a good match (better than 2 : 1) across the whole band. The 75 Ohm coax braid is connected to the lower side of the loop element. I don't use a balun as the antenna is not balanced, due to the offset side feedpoint, but do implement a coaxial choke at the 50 Ohm cable connection to the matching stub of 10 turns, 20cm diameter. The antenna is 7.71m per side, with the feed point 3/4 of the way down one side (5.78 m from the top) note; $3/4 * 1/3 \text{ wavelength} = 1/4 \text{ wave}$, this is important to obtain vertical polarisation.

This antenna is also effective on 15m provided open wire feeder is used up to the antenna instead of coax. I have found 10m DX performance to be rubbish! Simulation confirms this. The pattern is rather directional on both the higher bands.

Photo of the antenna

TBD.

Drawing of antenna

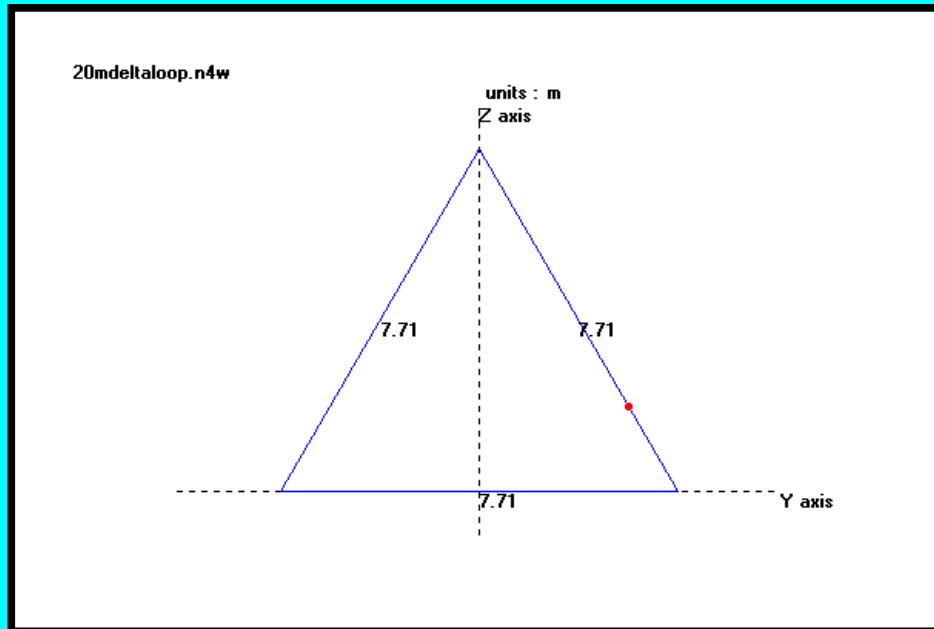

The NEC4WIN95 design file;

CM Equilateral Delta loop for 20 meters, apex up.

CM Feed point 0.25 lambda from top corner for vertical polarisation

CM 2:1 75 ohm coax quarter wave-length match assumed.

CM G4Ezt Tree supported antenna.

CE

GND Reference

UNITS Meters

Height 8.000

Over Ground 13.5 (Diel. - Cond. μ Siemens)

Boundary Circular

F 14.200

20m delta loop

GW 0 8 0.000 -3.854 0.000 0.000 0.000 6.675 0.002

GW 1 20 0.000 0.000 6.675 0.000 3.854 0.000 0.002

GW 2 8 0.000 3.854 0.000 0.000 -3.854 0.000 0.002

S 1 23 100 0

Coax 100

The SWR plot

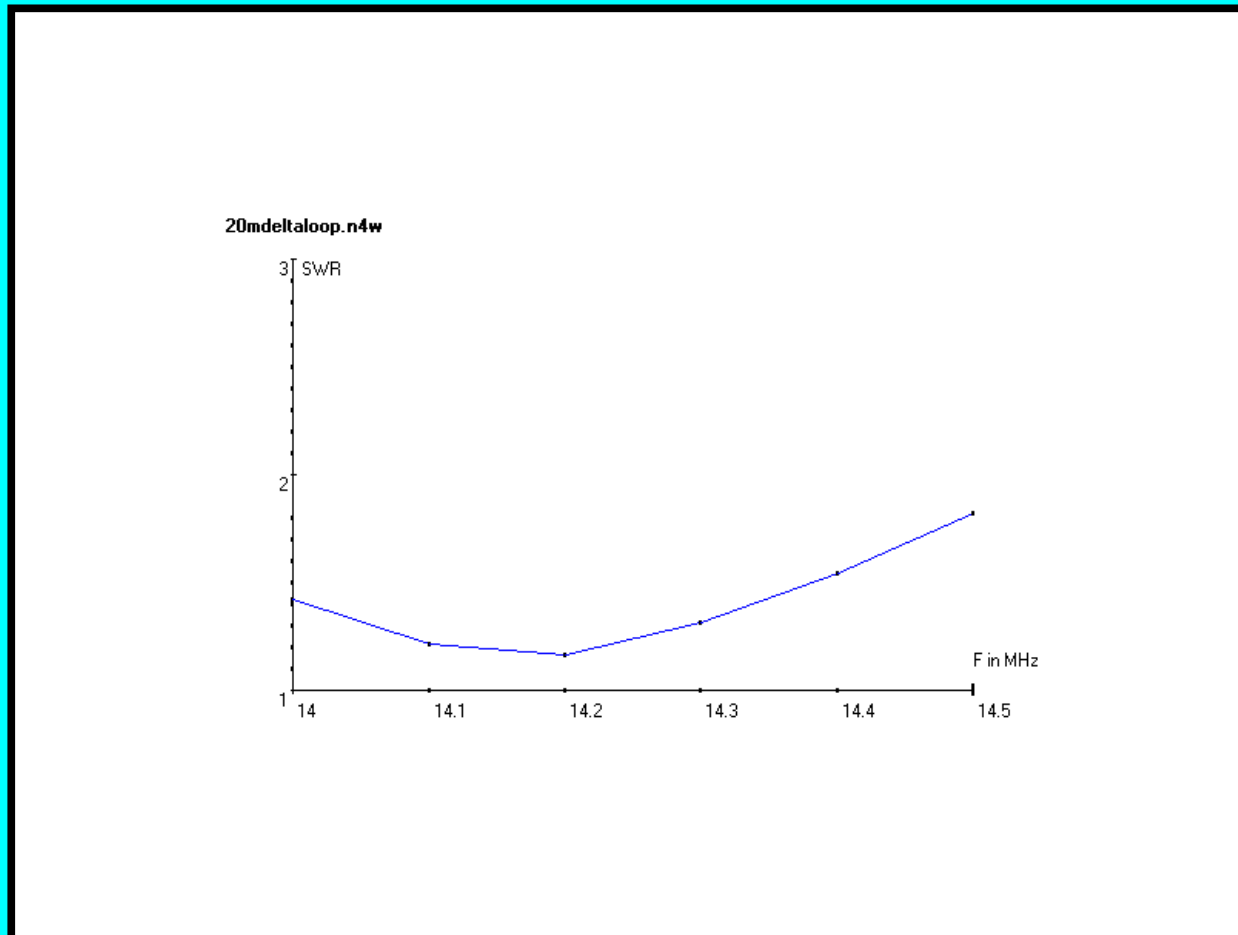

The Zenith plot

20MDELTALOOP.N4W Zenith Total Field

Frequency = 14.200 Mhz
Antenna Height is : 8 m (26.24ft)
Azimuth Angle = 0 deg.
Ground Diel. = 13 Cond. = 5
Z1 = 115.84 + j 3.58 (1.16)
Max = -0.13 dBd
Lobe at : 166° (BW:22°)
Lobe at : 130° (BW:29°)
Lobe at : 50° (BW:29°)
Lobe at : 14° (BW:22°)

0 dB = -0.13 dBd

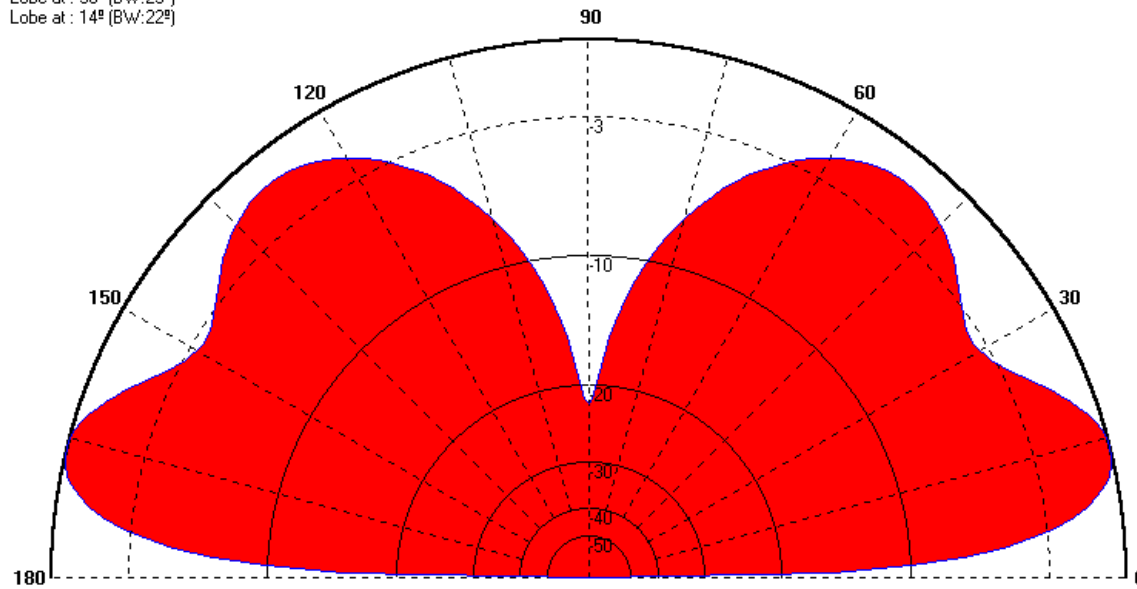

The Azimuth plot.

20MDELTALOOP.N4W Azimuth Total Field

0 dB = -0.12 dBd

Frequency = 14.200 Mhz
Antenna Height is : 8 m (26.24ft)
Ground Diel. = 13 Cond. = 5
Z1 = 115.84 + j 3.58 (1.16)
Zenith Angle = 14 deg.
Max = -0.12 dBd
F/B = 0.02 dB

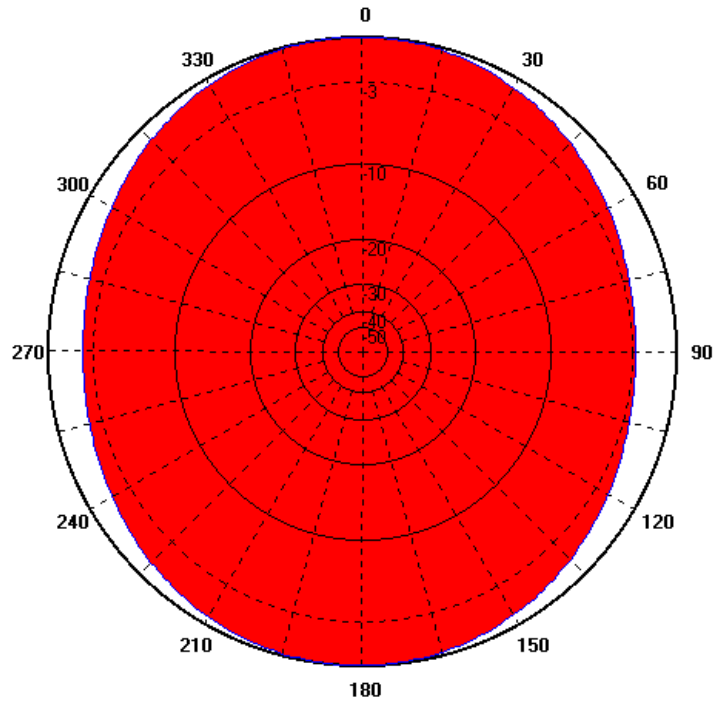



A ONE ELEMENT V BEAM FOR 15 METERS

"I REFER TO THIS AS MY **ONE ELEMENT BEAM**, IT'S A HORIZONTAL V!
IT OUTPERFORMED 2 ELEMENT BEAMS WE HAD ON 10 METERS AND 20 METERS IN LAST
YEAR'S FIELD DAY!

IT HAS GAIN IN A SINGLE ELEMENT DESIGN!

THE db GAIN, IF FIGURED BY THE BOOK, IS 3db OVER A DIPOLE!.....DARRELL REF 1

In log-periodic dipoles, it was found that forward tilt increased gain by a 3 to 4 db over a regular log dipole.
ref 2Horizontal V Antenna for 15 Meters

"The HORIZONTAL V ANTENNA FOR 15 METERS"

This often leads to the assumption of what is a Beam Antenna, in it smallest of states, the Horizontal Vee, must be one of the least researched or understood antennas, after stumbling on misleading data one would think the antenna to be a dud, that efforts to make such a antenna would be a waste of time. **This is far from the case.....DARRELL.**





This page is GRAPHIC
intensive,
please allow time to load!

A ONE ELEMENT BEAM FOR 15 METERS

CONSTRUCTION DETAILS

In log-periodic dipoles it was found that forward tilt increased gain by a 3 to 4 db over a regular log dipole. Ref2

A little history , 3 years ago, I was using a rotatable dipole for 15 Meters and had good results but wanted something better. This dipole was built with a DAK dipole mount and used 36 inch extenders with 6 foot 10 7/8 inch fiberglass CB whip antennas. This worked well, but I wanted something a little better. I spent more time reading about antennas and got interested in the Horizontal V antenna and found that the basic V starts at 1/4 wave with a 90 degree angle. Ref 1

Time to build and test my acquired knowledge.

The center of the antenna started life as 2 mirror mount CB antenna mounting brackets, the first piece was flat on both sides of 90 degree angle and a second 5/8 inch hole was added an equal distance on the other side.

The second mirror mount is heli-arc'd to the first piece, with the top piece horizontal and the bottom piece vertical with the pole mount going down. (See picture above) Welding was done at a local welding shop for a \$5 bill.

Now I use the insulated CB 3/8 by 24 antenna mounting kits. You can pick these up at Radio Shack but get 2 and get the ones with bolts and stay away from the flimsy screws. The kits come with 2 bolts, 2 long nuts, and the plastic insulators. Use one kit per 5/8 hole on top, going from back to front (bolt, insulator, thru antenna bracket, insulator, long nut). Also while at Radio Shack pickup a couple of heavy duty terminal ends for the end of your coax. The coax is done in a pigtail fashion and connected on the bolt side of the antenna insulator hole 3/8 dia with at least a #10 wire connector for your terminal ends.

My elements consist of two 6 foot 10 7/8 inch fiberglass CB whip antennas with 38 inch extenders.(See picture above) and note that the original dipole used 36 inch but do to the induction between the elements, the resonant frequency raised to 21.350 MHZ. The 38 inch extenders lower the frequency to 21.250 with a 1 to 1 SWR). I operated field day on 21.205 and only got chased off frequency twice and came back and retook the frequency, minutes later. The extenders were made

from 1/2 inch EMT tubing. On one end a 3/8 by 24 long nut is inserted leaving 1/16 inch exposed for soldering. Soldering was done with a 5% silver solder. On the other end a 3/8 by 24 bolt, 1 1/2 inch long, with a 3/8 by 24 nut attached to leave 1/2 inch of threads exposed was inserted in the other end leaving 1/16 of the nut exposed and the 1/2 inch of threads. The nut is soldered on the exposed 1/16 inch of nut, take care not to weld on the exposed 1/2 of treads. Two of these must be made.

The final assembly starts at the center antenna mount. Connect coax pigtail on bolt side of antenna center insulators, connect treaded side extender to center, connect whip to extender and repeat for the other side. (See picture above)

The entire 15 Meter antenna weights around 6 pounds and was used on a 20 foot tower with an 18 inch truck wheel for a base, no guy wires were used and it withstood a 30 mile per hour wind when a thunderstorm hit just after setup for field day 2001. It has performed better then I could ever have imagined. I learned what it was like to be in a pileup and have fun, we even worked **DX** and had 49 of 50 states in the 24 hour period! We had directivity, and rotating from NE to NW we lost the **DX**, but started working the Western States. I figure the gain over a vertical at around 6 db, and a walk around the Horizontal V with a field strength meter (see diagram above) was enough to tell me that this antenna will perform.

A fellow ham came by, **AF4HZ** Gordon Blauser and I let Gordon walk around with the field strength meter and he walked away amazed with how good the antenna performed with 10 watts running to it.

He got one of the proto type centers and was vowing to try using 2 hamsticks on his V. I also have to get Spencer Whitmire, **W4ERC**'s report on how another proto type center is being tested on 6 Meter with just a couple of stainless steal whips cut down to around 52 inches that will work on the Magic Band.

The center antenna mount could be made with a 6 or 8 inch longpiece of aluminum angle 2 inch by 2 inch and 1/4 inch thick. This should give plenty of space for the mast clamp. Nay sayers may say that the aluminum mast affected the radiation pattern but it worked for the good of the antenna.

Using the 36 inch & 38 inch extenders together with the whips puts the antenna on 17 Meters, Previous experiments with a different length whip on the 36 inch extenders enabled operation on 12 Meters. I lost this bit of research and suppose that with adjustable extenders (which I haven't designed yet) would do the trick of getting multi-band coverage, but below 20 Meters the antenna would lose the ability of 1 man erection. Remember this antenna is directive and is rotated when used in the field and is done by the arm strong method, and if guyed, use guy wires on a slip ring.

**THIS IS THE BEST PERFORMING ANTENNA I HAVE EVER BUILT!
DON'T LET THE SIZE FOOL YOU.**

All that is required to use this antenna is a willingness to give it a try and then look at the results.

It then comes down to operator skill as to how many contacts you can do per minute.

**It truly is AMAZING!
Darrell Koranda KB4XJ**

Reference 1 The ARRL Antenna Book 1994, page 13-2 (chart gain of single long wire over a dipole\0-db), page 13-5 (2 long wires placed in Horizontal V, give a 3 db gain over chart on page 13-2)

Reference 2 The ARRL Antenna Book 1994, page 10-20 (forward tilt of elements, gain increase of 4 db) log-periodic V array as compared to log-dipole

Editors note: If you decide to "copy or print" the construction details for this project please note they are in two different text blocks. Copy one at a time for best results. Please give credit to **KB4XJ** for this fantastic project!

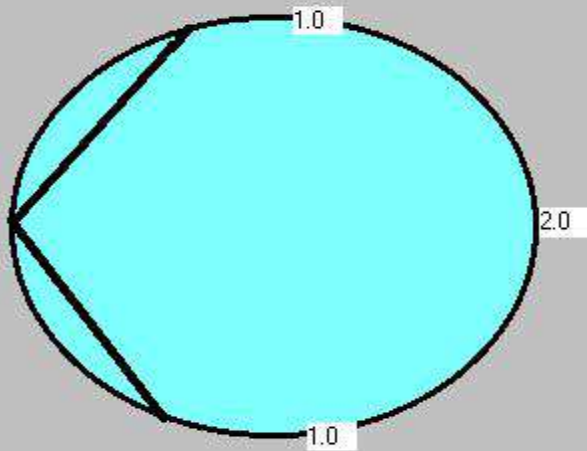
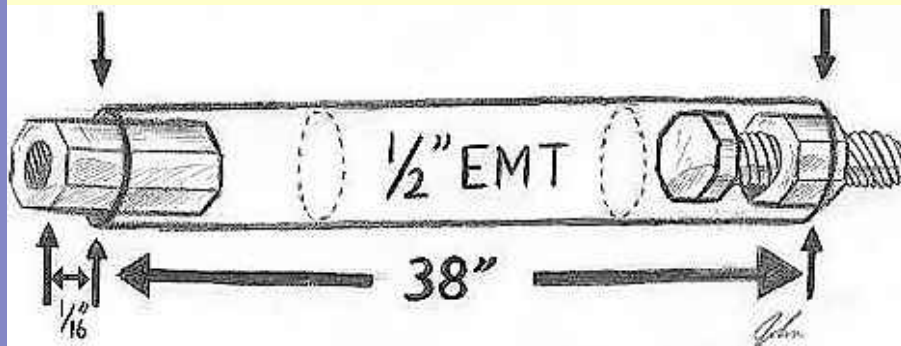

**Top View Radiation Pattern estimate
with field strength meter**

**Front to back Field strength ratio
18db**

**Extender is 38" long for 21.250mhz with 6'10 7/8' whip.
Extender is 36" long for 21.350mhz with same whip.
Extender is 38" + 36" for 17 meters with srw 1.4 to 1**

**Extender element scetch scaled down for
detail**

3/8 X 24 LONG NUT >>>

**3/8 X 24 BOLT
1 1/2 " LONG
<<<<<<WITH
3/8 X 24 NUT**

**WELD
WELD**

COAX CONNECTION AND MOUNT

**BROKEN DOWN FOR
FIELD DAY PACKING**

**TRUCK WHEEL
USED AS
BASE >>**

EXTENDER ELEMENTS

THE ONE ELEMENT V BEAM!

A PROJECT BY
KB4XJ

element
attaches
here>>>

<<<<and here

FOOTNOTES ADDED BY DARREL..... KB4XJ

The dipole formula of $468/\text{freq}$ will work but, an extra 2 inches must be added to the final result.

The induction between the elements changes the resonant frequency of the antenna, and with a dipole cut for 21.250 Mhz (SWR 1:!) when folded into the V shape, the induction of the elements moves the frequency UP to 21.350 Mhz (SWR 1:1).

The Basic principle of the V antenna, when dealing with the rf radiation lobes are that the lobes in the bisector of the V tend to add and the other lobes tend to cancel.

A CHALLENGE

I'am President of the Local Ham Radio Club, and the chairman of the upcoming Field Day 2002. My 20 Meter operator has vowed revenge for the beating he got in last years Field Day from the One Element Beam and has stated that he's going to give me a run for the money and has bought a NEW antenna which will replace his 2 element butterfly beam. I accepted his challenge and told him I would be using my V and that I wanted his competition AND that I wasn't going to roll over and give up just because he got a new antenna.

The proto-type 6 Meter Horizontal V will be used by Spencer Whitmire W4ERC, the Vice President of the local radio club, Spencer was on 10 Meters with a 2 element beam and was converted to a believer when he saw the V in operation in last year's field day.

Spencer will give 6 Meters a try with the V.

Our callsign for Field Day 2002 will be **K4W** (Kilo Four Whiskey).

I became an EXTRA in 12-4-98. The One Element Beam is the results of several years of work on various antennas, I was really depressed with the results of tests on so called big signal antennas and finally went back to the horizontal dipole with good reports. I remembered from my beginning in ham radio about the inverted V that I used on 75 Meters and how I could get into Hawaii. I also remembered that an inverted V could be made directive by the leg angle. This was the turning point which led to the **ONE ELEMENT BEAM!**

While reviewing the logs of last years field day, I found KH6, VE6, VE3, VE4, VE5, KP4, VE7, NP2, DJ2, NP4, TZ6, GO6, VE1, VE9, XE1, RX3, DL6, EA4, OH4, G4, G0, EA5, EA3, DL1, OH1,

RA3, DJ2, F6, PA3, F5, F6, AND VE2. I found these prefixes in the log book of the DX worked during field day, with the Horizontal V. Darrell...KB4XJ

[E-Mail address kb4xj@strato.net](mailto:kb4xj@strato.net)

"Many thanks to Darrell for all his efforts, hard work and DEDICATION TO HAM RADIO while getting this great project up and running for all hams to enjoy!"

N4UJW HAMUNIVERSE.COM

[BACK TO ANTENNA LAB](#)

SCETCH BY JOHN BUTLER
SON OF N4UJW

15822



Satellite TV the way I want it!
No Equipment to buy!

Why pay full retail for inkjet supplies when you can save between 50%-70%! [Click here and start saving!](#)

NEW!

20 THRU 6 METER VERSION

BY

LA0HV OF NORWAY

[CLICK HERE!](#)

[PLEASE KEEP HAMUNIVERSE](#)

[FREE](#)

[CLICK HERE](#)

**Tri- Bander Project
Coming Soon from
KB4XJ**



HAMUNIVERSE.COM

Your Source for Ham Radio Fun and Information!



A comparison of 10 meter verticals using modeling

I decided to test a few versions of popular ten meter verticals using elnec demo to test. I have had trouble in the past trying to convince people I was using a 5/8 ground plane with decent success. And I could see their point as normally a 5/8 ground plane has a fairly high angle of maximum radiation. But a major difference was I have been using 3/4 wave radials instead of the common 1/4 wave versions. I found what I think is the reason I have had fairly good success. But I also found a few things I was doing wrong in earlier versions. I found for maximum gain, I would be better off using 5/8 wave radials instead of the 3/4 wave. I had assumed in the past that being the 3/4 wave radial would be resonant and the 5/8 would not be, that the 3/4 would be better. But modeling this antenna, this doesn't seem to be the case. I found using 5/8 radials and sloping at a steep angle to the ground, would give the most gain. With the antenna acting more as a dual 5/8 collinear than a 5/8 radiator with a 5/8 wave ground plane.

Don't have elnec or ez nec? You can download a demo version here at <http://www.eznec.com/elnecdem.htm>

I will show the plots of the popular 10 meter verticals. All antennas are modeled at the 40 ft level. I'll start with the 1/4 wave ground plane with 4 sloping radials.

This is the elevation plot over average ground with the antenna at 40 feet.

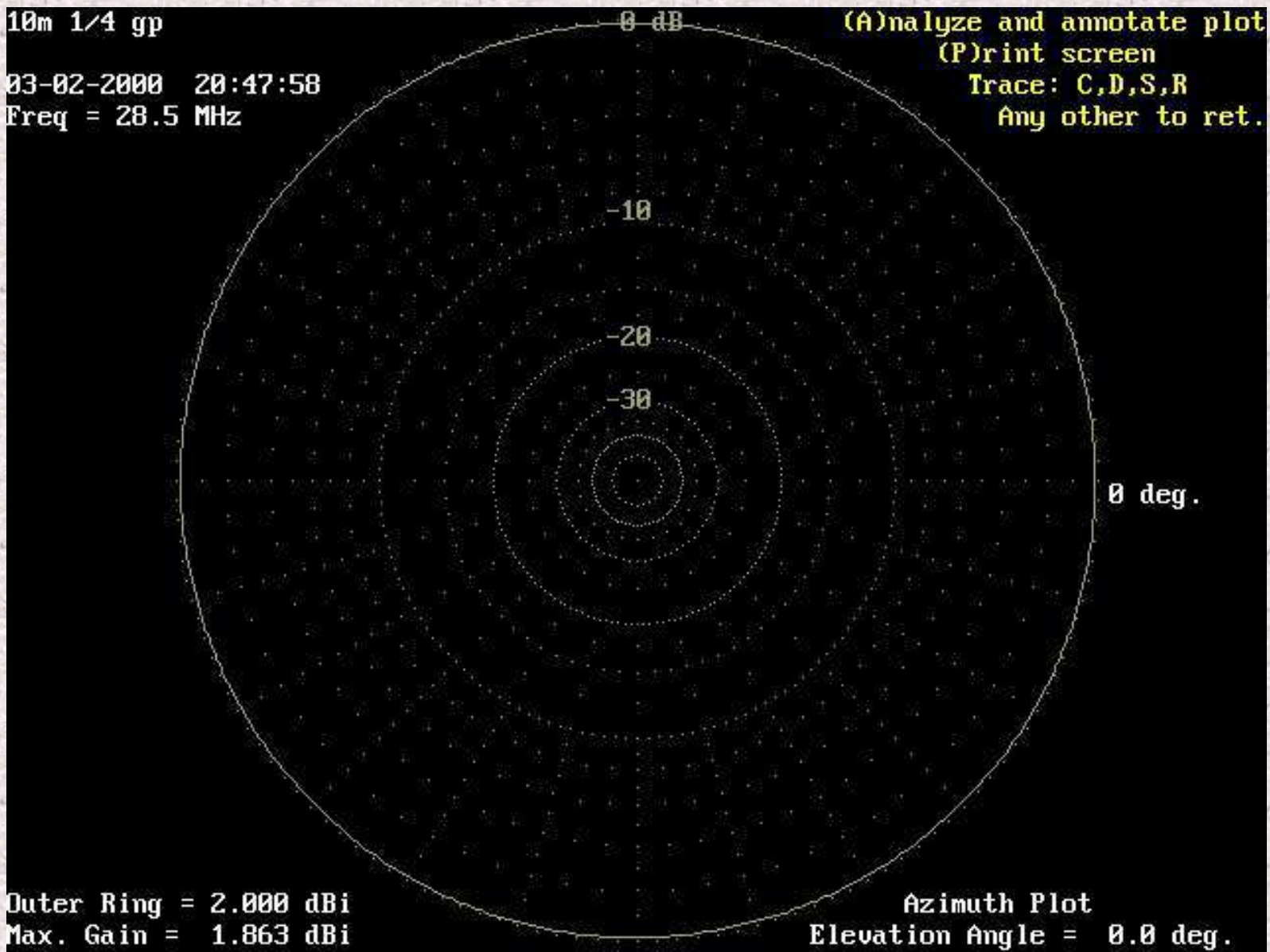

And a view of the antenna showing the current distribution

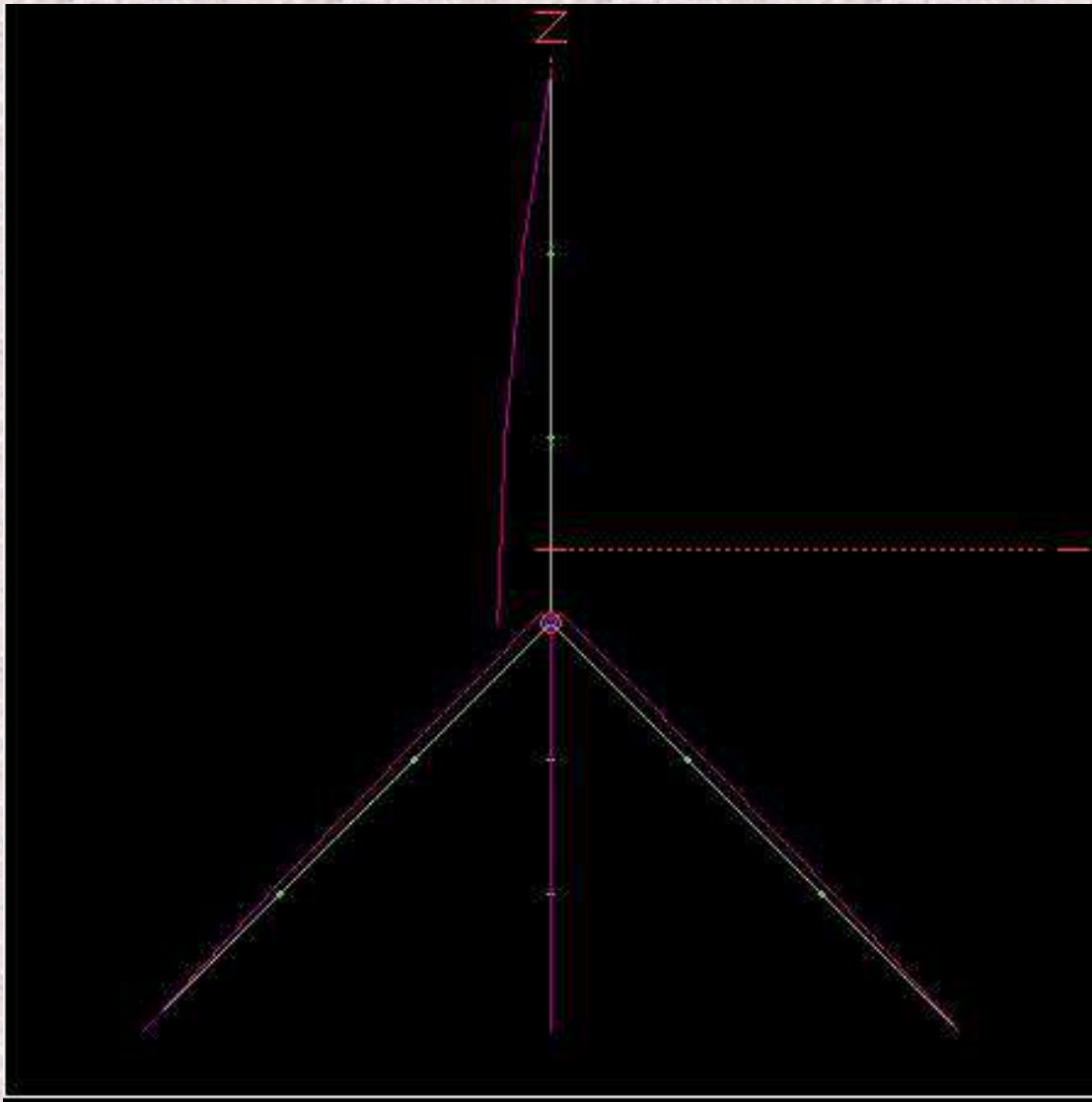

Page 1

[Go to page 2-The half wave vertical](#)

Page

[\(1\)](#) [\(2\)](#) [\(3\)](#) [\(4\)](#) [\(5\)](#) [\(6\)](#) [\(7\)](#)

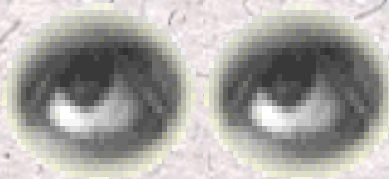

[Back to Homepage](#)

The DF9CY Three-Element Antenna for 28 MHz

Christoph Petermann DF9CY 1999



[A better view of the 3 element for 28 \(and the 6 element for 50 MHz\)](#)

My 3-Element for 28 MHz antenna is mounted below my 6 element for 50 MHz

The 3 element is a commercial antenna by PAN International, which I slightly modified for good performance on the 10m Amateur-Radio band.

Design Frequency: 28.300 MHz

- **Usable Bandwidth: 600 kHz**
 - **Return loss: better than 20 dB with center at 28.270 MHz**
 - **Gain: > 7.5 dBi**
 - **Front/Back ratio: > 20 dB**
-

DF9CY 3 Element Yagi for 28 MHz

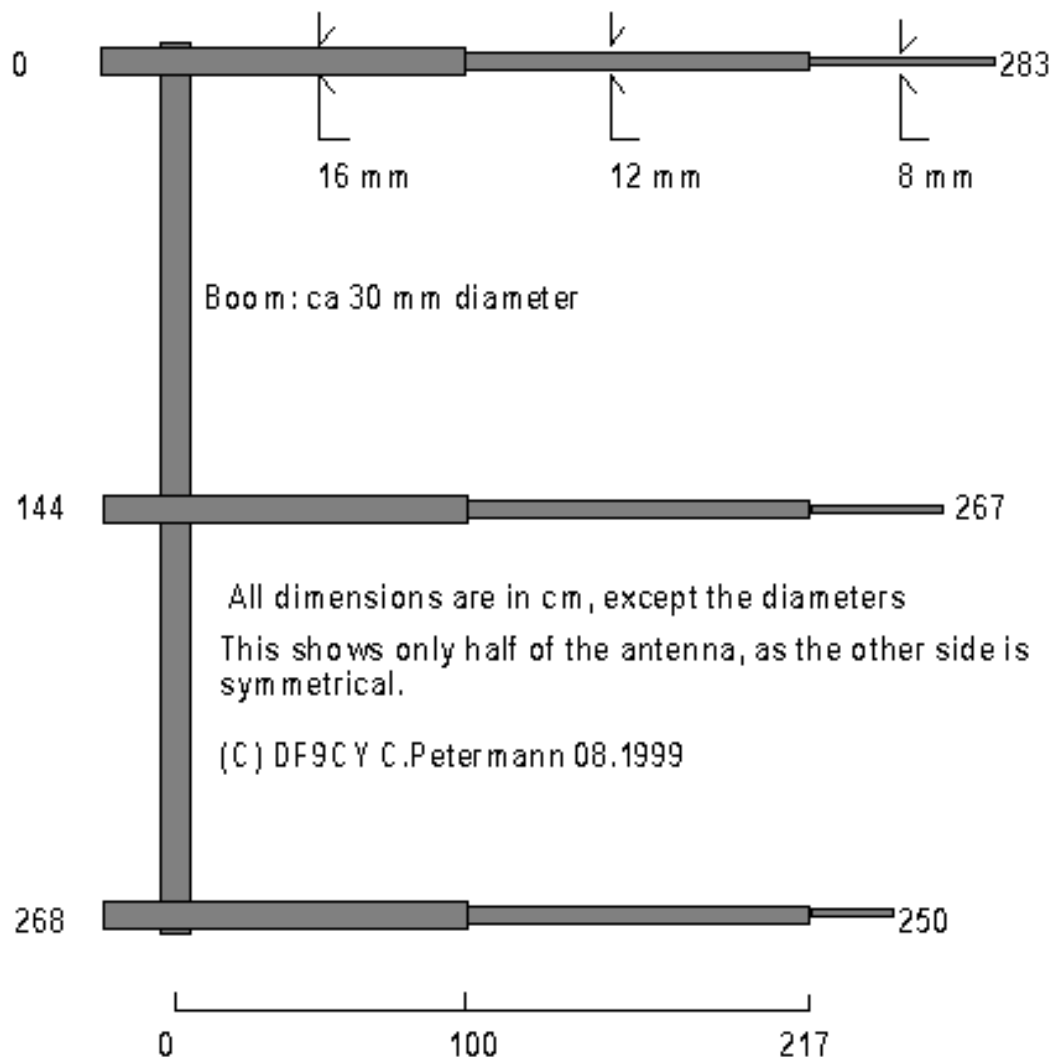

This antenna is a commercial CB Radio antenna distributed by *PAN International*. For this kind of antenna it looked quite robust and indeed it survived a wind storm with wind speeds up to 160 km/h.

Feeding the antenna

This antenna is fed by a gamma match. Setting up this antenna was very easy. Position of the gamma match as approximately moving the bracket as far inside as possible and the inner conductor "looks out" by 70 mm at the end.

Modify the elements

Calculating the antenna with EZNEC gave already very good results. The redesign for 28.270 MHz resulted in shorting each elements' end by 40 mm. This is indeed very easy, as there exist two holes for self-cutting screws separated by 40 mm. Move the outer element in by one hole, fix it with a screw and drill a hole for the second screw. Ready. You shall better not use the screws delivered with the antenna as they tend to oxidation (rust) very

quickly. I bought a complete new V2A set of screws and I have no problems. The elements are electrically connected to the boom. What I dislike is the SO239 connector "popped" to a sheet of metal. I will replace this by a N-Connector now.

Performance

The antenna is up since October 1998 and performance is good. Contacts were made with all continents using my TS690 with about 90 Watts output. It does not perform as our "pile-up-cracker" does, but I feel it works better than a tribander. The antenna is installed at about 9 m above ground. This is indeed not very high, but the surrounding terrain descents in most directions putting the antenna virtually to a higher position. The feedline I use is a low-loss UHF cable (AirCell 2000) with less than 0.4 dB of loss on the 22m run. I also used it with 750 Watts output from a 3-500 for a while and it did a fine job.

EZNEC

Here is the EZNEC simulation file: [cy28-3dopt.zip](#)

DIAGRAMS AND SIMULATIONS

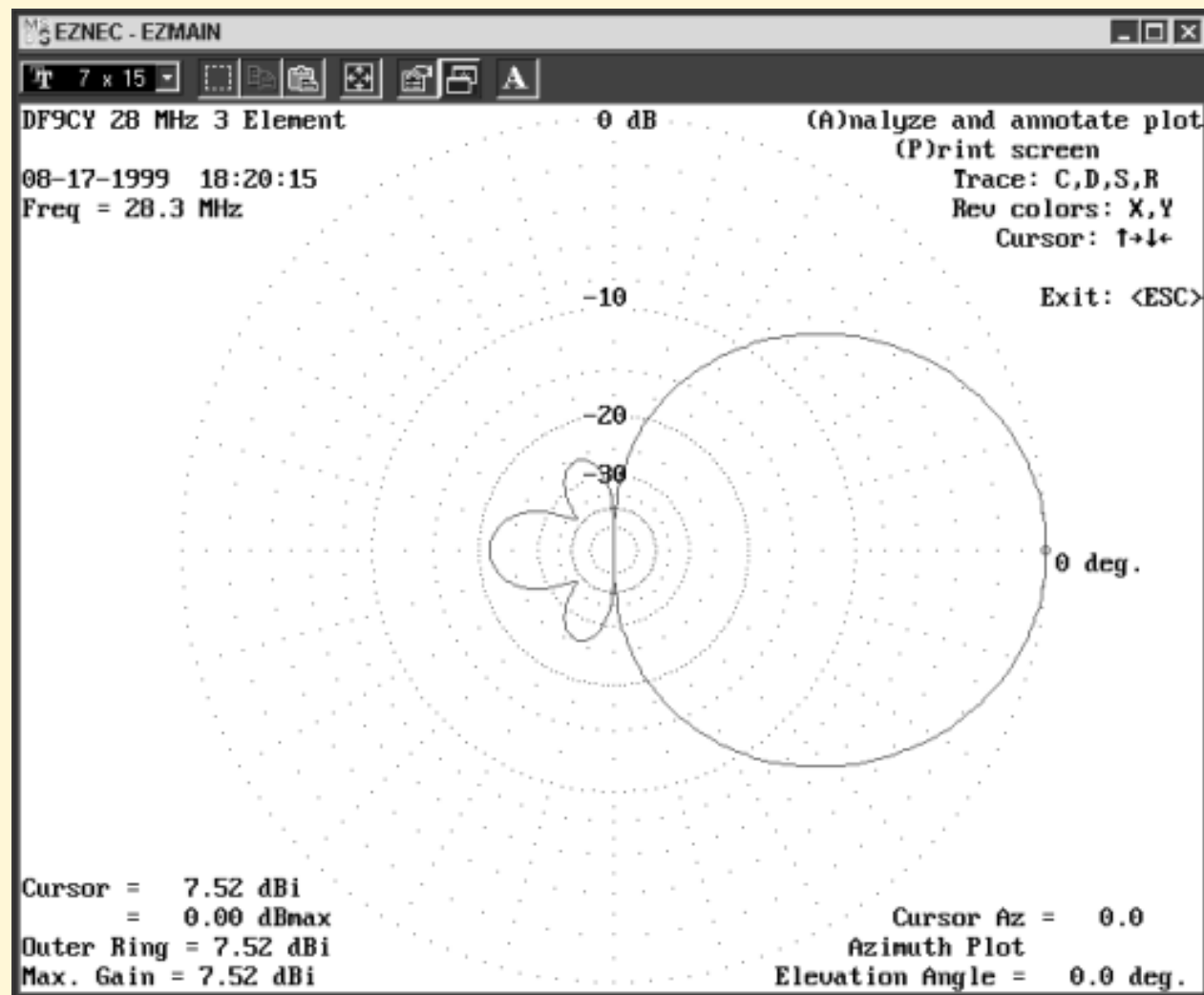

Azimuth diagram of the 3 Element for 28.3 MHz. Note the good front to back ratio.

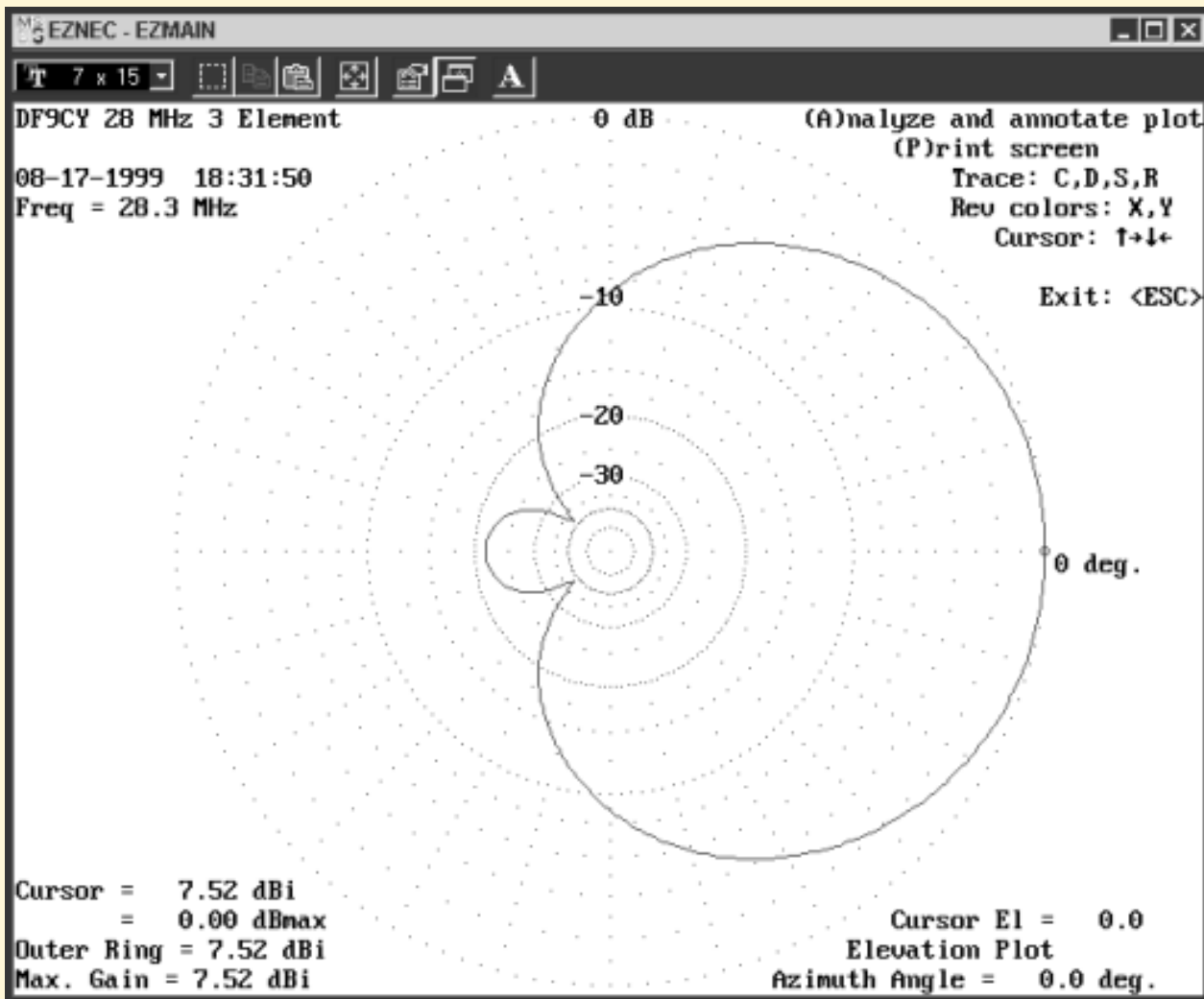

Elevation diagram. Vertical attenuation is around 10 dB.

My special thanks go to Roy Lewallen W7EL for programming this fantastic *EZNEC 2.0*

If you want to have more background knowledge on antennas and how-to make them, you will find an ultimate resource here:

[W4RNL](http://www.w4rnl.com)

L.B.Cebik W4RNL ultimate ANTENNA Site. A must !

Mail any comments to: df9cy.petermann@t-online.de

Text and All Images are Copyright by Christoph Petermann DF9CY

GO (back) and visit my [homepage](#)

VHF / UHF Direct Connect Beams

Here are some lengths and spacings for various direct connect beams. The layouts are straight forward and are illustrated below. Your SWR should be less than 1.3:1 with these designs.

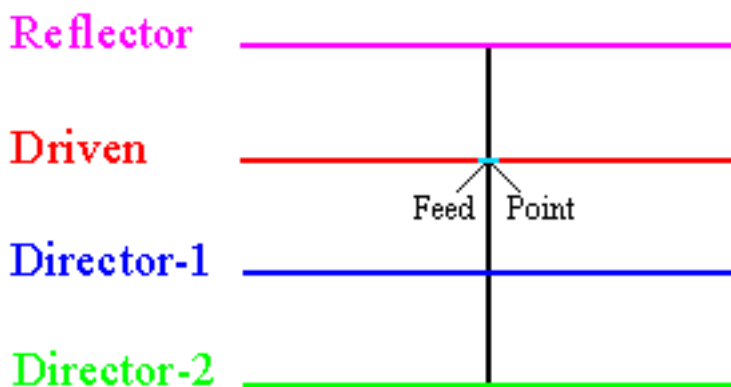

The driven element is cut into two halves and insulated from the boom with nonmetallic material. Then the two wires of the coax are connected, one to each section of the driven element. You may drill small holes and use sheet metal screws to accomplish this.

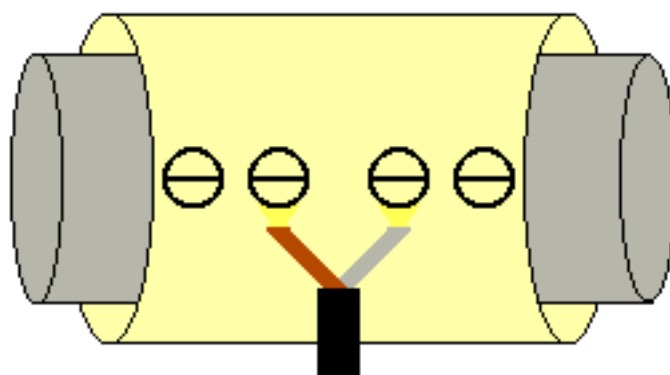

The reflector, director 1, and director 2 can be attached directly to the boom by a variety of methods. There are some helpful hints for antenna construction on our [antenna construction tips page](#).

70 Centimeter 2 element beam center frequency 440 MHz

| 70 Centimeter 2 element beam 1/8" diameter tubing | Element Length | Element spacing from Reflector |
|--|-----------------------|---|
| Reflector | 12-3/8" | ***** |
| Driven | 12-1/8" | 6-1/2" |

| | Freespace | Over ground 30 feet |
|--------------|------------------|---|
| Gain | 4.17 dbd | 8.08 dbd @ 5 degrees 9.48 dbd @ 14 degrees |
| F / B | 4.01 db | 4.0 db |

70 Centimeter 4 element beam center frequency 440 MHz

| 70 Centimeter 4 element beam 1/8" diameter tubing | Element Length | Element spacing from Reflector |
|--|-----------------------|---|
| Reflector | 13" | ***** |
| Driven | 12" | 8-1/16" |
| Director 1 | 11-7/8" | 16-3/4" |
| Director 2 | 11-3/4" | 23-3/8" |

| | Freespace | Over ground 30 feet |
|--------------|------------------|---|
| Gain | 8.19 dbd | 12.78 dbd @ 5 degrees 13.05 dbd @ 14 degrees |
| F / B | 11.15 db | 11.2 db |

2 Meter 4 element quad center frequency 145.000 MHz

| 2 meter 4 element quad #12 copper wire | Element Length | Element spacing from Reflector |
|---|-----------------------|---|
| Reflector | 21-1/4" | ***** |
| Driven | 21" | 23-1/8" |
| Director 1 | 20-1/4" | 46-1/4" |
| Director 2 | 20-3/16" | 74" |

| | Freespace | Over ground 30 feet |
|--------------|------------------|--|
| Gain | 8.87 dbd | 10.24 dbd @ 5 degrees 13.87 dbd @ 8 degrees |
| F / B | 8.57 db | 8.7 db |

2 Meter 4 element beam center frequency 146.52 MHz

| 2 Meter 4 element beam 1/2" diameter tubing | Element Length | Element spacing from Reflector |
|--|-----------------------|---|
| Reflector | 38-1/8" | ***** |

| | | |
|-------------------|---------|---------|
| Driven | 36" | 24-1/4" |
| Director 1 | 34-1/2" | 49" |
| Director 2 | 34-3/8" | 71-1/2" |

| | Freespace | Over ground 30 feet |
|--------------|------------------|---|
| Gain | 8.43 dbd | 10.34 dbd @ 5 degrees 13.71 dbd @ 10 degrees |
| F / B | 13.32 db | 13.60 db at 5 degrees |

2 and 6 Meter 4 element quad center frequency 146.520 / 52.000 MHz

| 2 and 6 Meter 4 element quad #12 copper wire | Element Length | Element spacing from Reflector |
|---|-----------------------|---|
| 6 Meter Reflector | 60-1/4" | ***** |
| 6 Meter Driven | 57-9/16" | 48-3/8" |
| 2 Meter Reflector | 21-1/4" | 54" |
| 2 Meter Driven | 20-1/2" | 77-1/4" |
| 2 Meter Director 1 | 20-1/4" | 100-1/4" |
| 6 Meter Director 1 | 57-1/16" | 104-3/4" |
| 2 Meter Director 2 | 20-3/16" | 128" |
| 6 Meter Director 2 | 49-1/2" | 181-15/16" |

| | Freespace | Over ground 30 feet |
|-------------|------------------|--|
| Gain | 8.3 / 8.35 dbd | 13.97 dbd @ 2 degrees 13.79 dbd @ 8 degrees |

| | | |
|--------------|-----------------|-----------------|
| F / B | 7.86 / 15.84 db | 8.12 / 16.59 db |
|--------------|-----------------|-----------------|

6 Meter 3 element beam center frequency 52.000 MHz

| 6 Meter 3 element beam 1" diameter tubing | Element Length | Element spacing from Reflector |
|--|----------------|-----------------------------------|
| Reflector | 109" | ***** |
| Driven | 101-5/8" | 64-15/16" |
| Director 1 | 96-3/4" | 125-3/16" |
| | | |

| | Freespace | Over ground 30 feet |
|--------------|-----------|---|
| Gain | 6.5 dbd | 9.99 dbd @ 5 degrees 12.01 dbd @ 8 degrees |
| F / B | 8.99 db | 9.25 db |

6 Meter 4 element beam center frequency 52.000 MHz

| 6 Meter 4 element beam 1/2" diameter tubing | Element Length | Element spacing from Reflector |
|--|----------------|-----------------------------------|
| Reflector | 109-7/8" | ***** |
| Driven | 104-1/4" | 72" |
| Director 1 | 100.5" | 138" |
| Director 2 | 100" | 204" |

| | Freespace | Over ground 30 feet |
|--------------|------------------|--|
| Gain | 8.2 dbd | 11.78 dbd @ 5 degrees 13.76 dbd @ 8 degrees |
| F / B | 14.44 db | 15.28 db |

10 Meter beam center frequency 28.450 MHz

| 10 Meter 3 element beam 1/2" diameter tubing | Element Length | Element spacing from Reflector |
|---|-----------------------|---|
| Reflector | 207-1/2" | ***** |
| Driven | 192" | 105" |
| Director 1 | 185" | 210" |

| | Freespace | Over ground 30 feet |
|--------------|------------------|--|
| Gain | 6.33 dbd | 5.49 dbd @ 5 degrees 11.49 dbd @ 10 degrees |
| F / B | 10.21 db | 10.37 db |

[Antenna Construction Tips](#)

[Back to the Antenna Elmer](#)

[Back to the Home Page](#)

All trademarks mentioned belong to their respective owners.

The content on this page is provided as is, and should be accepted and used without expecting any particular fitness for any particular purpose. No liability is assumed with respect to the use of this information.

© Copyright 1996 – 97 Edward Oros and Bob Cocco

[Home](#) -> [Antennas](#) -> LPDA[Wire-Yagi](#) [More-Yagis](#) [LPDA](#) [Six-Meters](#)

A 5 BAND LOG PERIODIC DIPOLE ARRAY

In ARRL Antenna Compendium No. 4, I described how I modified the Telerana which was originally featured in the July 1979 issue of QST. The unique feature of the Telerana is that the elements are wire instead of aluminum tubing which makes for a light weight LPDA (log periodic dipole array). The array is suspended within a framework made of fiberglass poles emanating from a central hub with the ends tied together with light weight rope around the perimeter.

Here is a picture taken of the Modified Telerana taken from below.

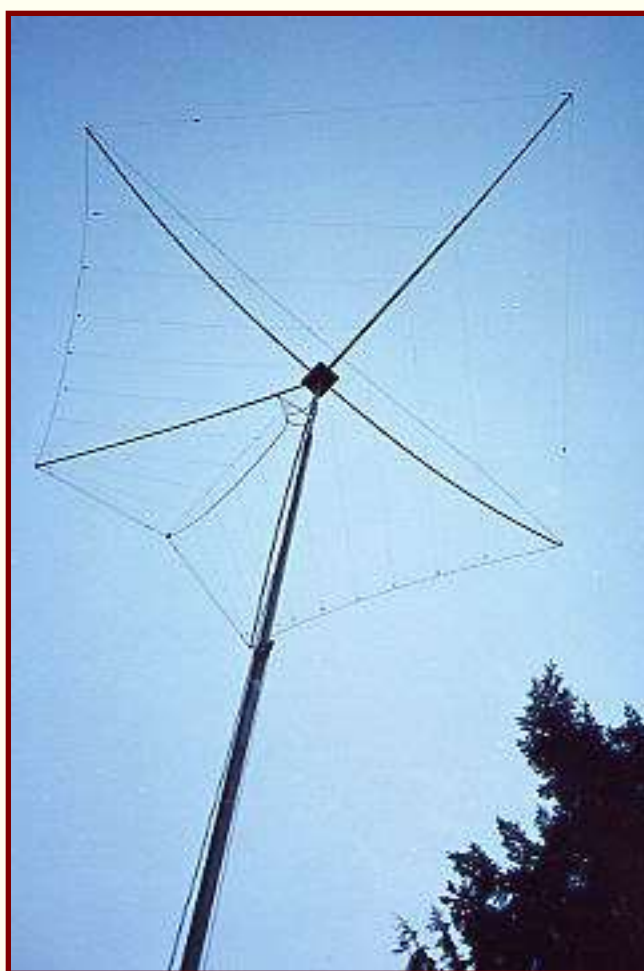

Modifications to the original Telerana design included adding parasitic reflectors for 15 and 20 meters to improve the front to back ratio on these bands. I also described how I added a trap 30/40 meter inverted Vee that acts as a top truss system to keep the Telerana from turning upside down like an umbrella might in high winds. Below the modified Telerana is a homemade 4 element 6 meter Yagi. This system allows coverage of all amateur radio bands from 40 to 6 meters without an antenna tuner, on one tower, with only 3 coax feed lines. A very compact system that works very well.

I have been using this antenna system since 1986. It is supported by a Wilson telescoping tubular tower with the modified Telerana at 62 feet and the apex of the 30/40 trapped inverted Vee at 72 feet. I have worked 293 countries and confirmed QSLs from 275 countries with this system! As well, I have worked 121 countries at QRP levels!

Vol 4 of the ARRL Antenna Compendium series is no longer in print however I have scanned a copy of [the article, "The Improved Telerana, with Bonus 30/40 Meter Coverage, here](#)

(Copyright ARRL. All rights reserved, used with permission of the ARRL.)

You may also find an abbreviated version of the Modified Telerana article in recent ARRL Antenna Handbooks.

Using Moxon Rectangles for WARC-Band Antennas

Part 2: Some 30-17-12 Meter Ideas

L. B. Cebik, W4RNL

Last month we looked at the Moxon rectangle, cut for 17 meters, as the basis for a very compact dual-band Moxon-Yagi for 17 and 12 meters. The design used open-sleeve coupling between the physically driven 17-meter driver and the slaved 12-meter driver. The Yagi portion was a standard driver-director design with about 0.07 wavelength spacing. The result was a two-band array about 10' long and 20' wide that provided over 6 dBi free-space gain, better than 20 dB front-to-back ratio, and a direct feed with 50-Ohm coax (with, as always, a recommended choke or 1:1 balun to attenuate common-mode currents).

Compactness: this goal was one of the good reasons for using a Moxon as the basis for the dual band beam. The width of a Moxon is only about 70% that of a full size Yagi with a driver and reflector, and the Moxon uses no loading to achieve the shortening. Instead, it bends the elements around to point toward each other. By selecting the correct proportions and tip-to-tip spacing, one can obtain a parasitic driver-reflector array with nearly the gain of the full size Yagi and considerably improved front-to-back ratio over the Yagi. Part of the reason for the excellent front-to-back performance lies in the current magnitude and phasing on the rear element relative to the front element: they are close to what one might obtain with each element driven to perfection for maximum rearward rejection.

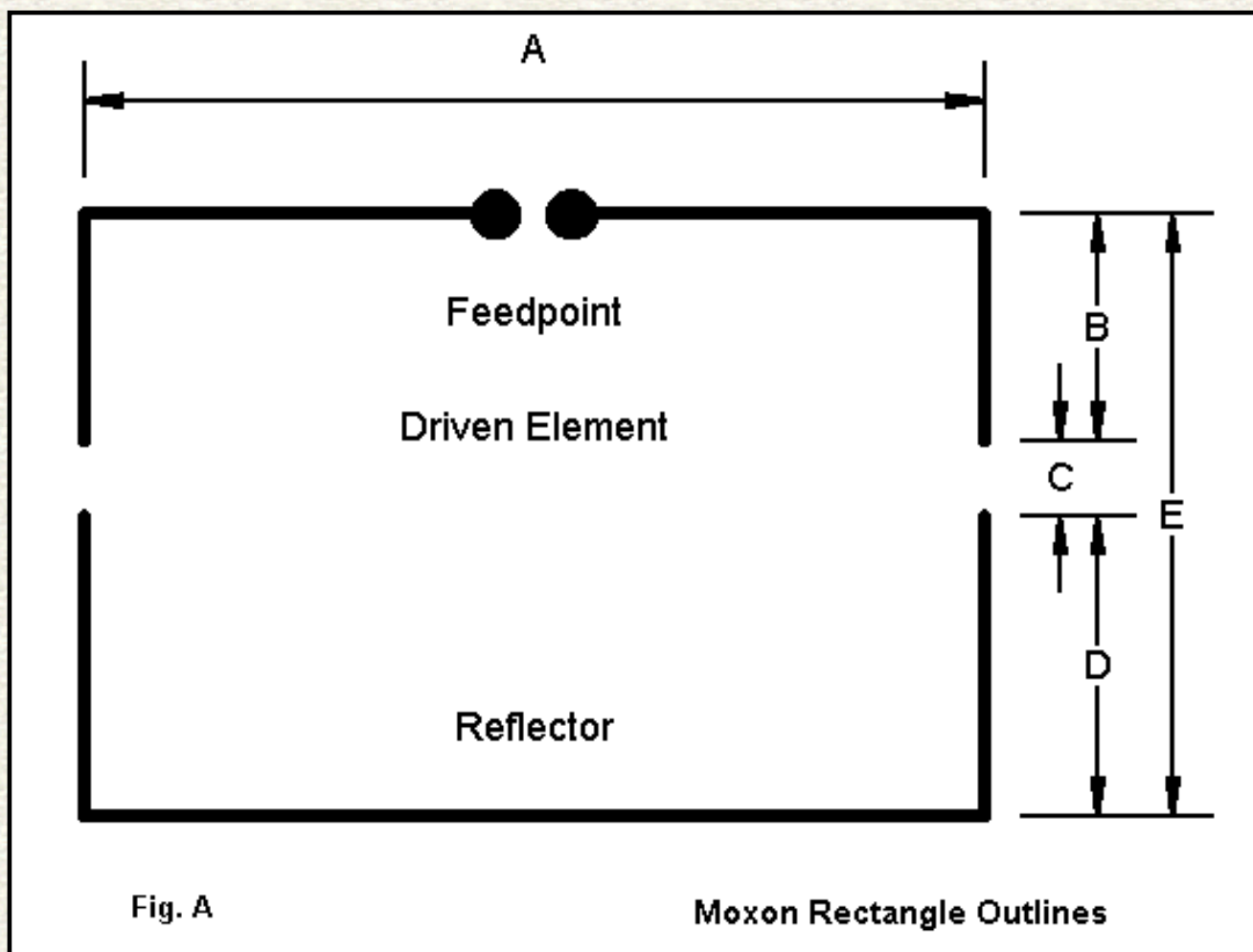

Fig. A provides an outline sketch of a basic Moxon, a refresher. As well, the portions of the Moxon structure are identified, since we shall once more provide some design ideas involving this antenna. However, this month, we shall include 30 meters.

A 30-meter Yagi with unloaded elements would be about 48' to 49' side-to-side. A Moxon rectangle for 30 meters requires only 35' of side-to-side space, and about 13' front-to-back. These dimensions are close to those for a common 20-meter beam. The structure of a 30-meter Moxon might have to be a bit beefier than that of a 20-meter Yagi, since the parallel element must support the "tails" (B and D in **Fig. A**). Nonetheless, for those with space limitations, 35' elements are usually easier to sustain than 48' elements.

A 30-17 m Combination

When we examined the possibilities for 17 and 12 meters, we reached two practical conclusions. First, a dual Moxon array may be too sensitive to minor variations to be truly practical for home building. Second, placing a full size 12-meter Yagi of driver-reflector design inside the 17-meter Moxon was not feasible due to the length of the 12-meter elements--especially the reflector.

Therefore, we shall bypass a dual Moxon for 30 and 17 meters. However, we shall not forego the possibility of a full-size 17-meter Yagi placed within the frame of a 30-meter Moxon. The longest element of a driver-reflector Yagi for 17 meters is 27' and that should be no problem within the 35' dimension of the 30-meter Moxon. **Fig. 1** shows the general outline of the combination.

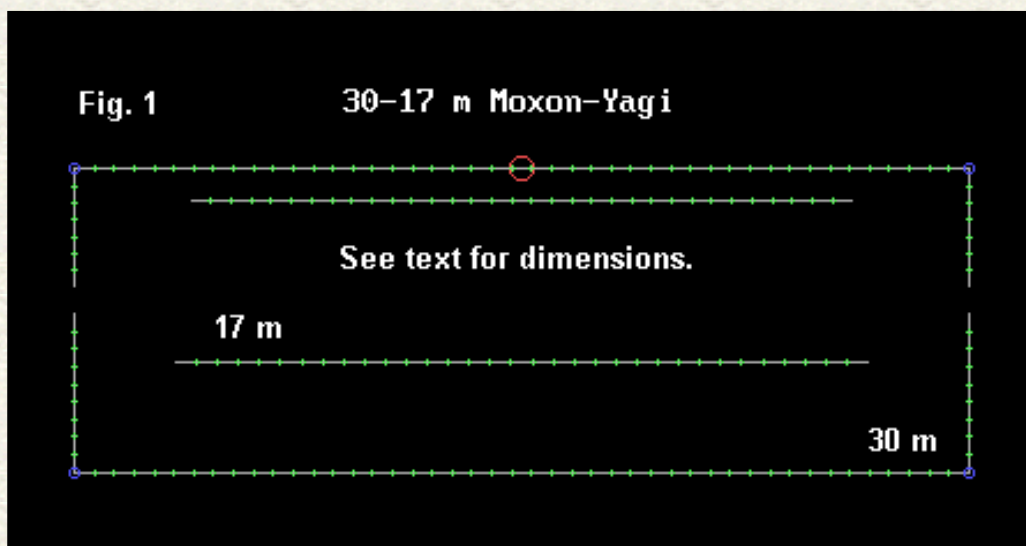

The following table of dimensions uses the designators of **Fig. A** for the Moxon. The Yagi element spacing entries are distances from the Moxon driver. All dimensions are in feet. The Moxon elements are 1.25" aluminum tubing, while the Yagi elements are 1" diameter aluminum tubing.

| Band | Dimension | Length (feet) |
|----------------|---|---------------|
| 30-meter Moxon | (all elements use 1.25" diameter aluminum tubing) | |
| Moxon | A | 34.91' |
| | B | 4.89' |
| | C | 1.12' |
| | D | 6.56' |
| | E | 12.57' |
| 17-meter Yagi | (all elements use 1.0" diameter aluminum tubing) | |
| Driver | Length | 25.80' |
| | Space | 1.30' |
| Reflector | Length | 27.00' |
| | Space | 8.00' |

The spacing between the Yagi elements is 6.7' or about 1/8 wavelength. The spacing of the Moxon elements is about 0.13 wavelength. The Moxon dimensions are unchanged from those optimized for maximum front-to-back and a 50-Ohm feed when used independently. Of course, changes in material dimensions or the use of stepped-diameter elements will require readjustment of the design to yield satisfactory performance. As I did last month, I shall place model descriptions at the end of these notes for those who wish to experiment with other material combinations.

However, once the basics are established, the only post-construction adjustment will be to the slaved 17-meter driver. Its exact length and spacing from the Moxon driver will determine the feedpoint impedance on 17 meters at the physical feedpoint.

The Moxon-Yagi combination is a very well-behaved. The following performance table, listing the gain in terms of free-space gain, gives a good general picture.

| Frequency MHz | Gain dBi | Front-to-Back Ratio dB | Feedpoint Z R+/-jX Ohms | 50-Ohm VSWR |
|------------------|-------------|---------------------------|----------------------------|----------------|
| 10.100 | 6.21 | 22.9 | 47.6 - j 3.6 | 1.09 |

| | | | | |
|--------|------|------|--------------|------|
| 10.125 | 6.13 | 27.0 | 50.7 - j 1.4 | 1.03 |
| 10.150 | 6.05 | 33.4 | 53.7 + j 0.6 | 1.07 |
| 18.068 | 6.37 | 10.8 | 52.4 - j22.5 | 1.55 |
| 18.118 | 6.26 | 10.9 | 49.9 - j 5.4 | 1.11 |
| 18.168 | 6.16 | 10.9 | 47.5 + j10.9 | 1.26 |

As we saw last month, the addition of a closely-spaced parasitic beam slightly detunes the Moxon in terms of moving the peak front-to-back ratio upward in frequency. However, the gain and the source impedance are mostly unaffected. **Fig. 2** provides a free-space azimuth pattern of the 30-meter Moxon performance at mid-band. One of the side-benefits of the Moxon rectangle design is that it tends to hold its high front-to-back ratio even down to a height of 3/8 wavelength--about 36' on 30 meters. Of course, the old rule that higher is better still applies. Nevertheless, even a modest installation can expect quite reasonable results on 30 meters.

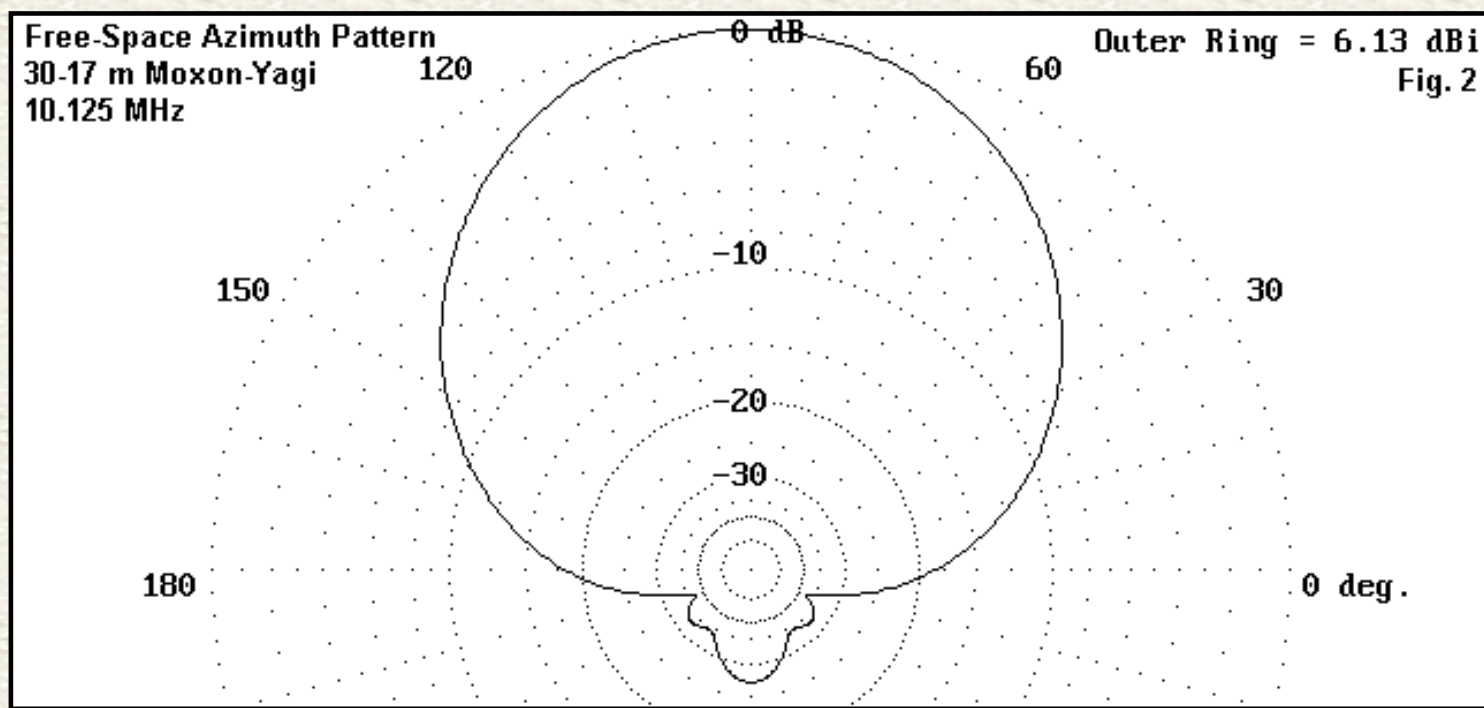

On 17 meters, we must expect the lesser front-to-back ratio associated with the driver- reflector Yagi design. **Fig. 3** shows the mid-band free-space azimuth pattern for the array at 18.118 MHz.

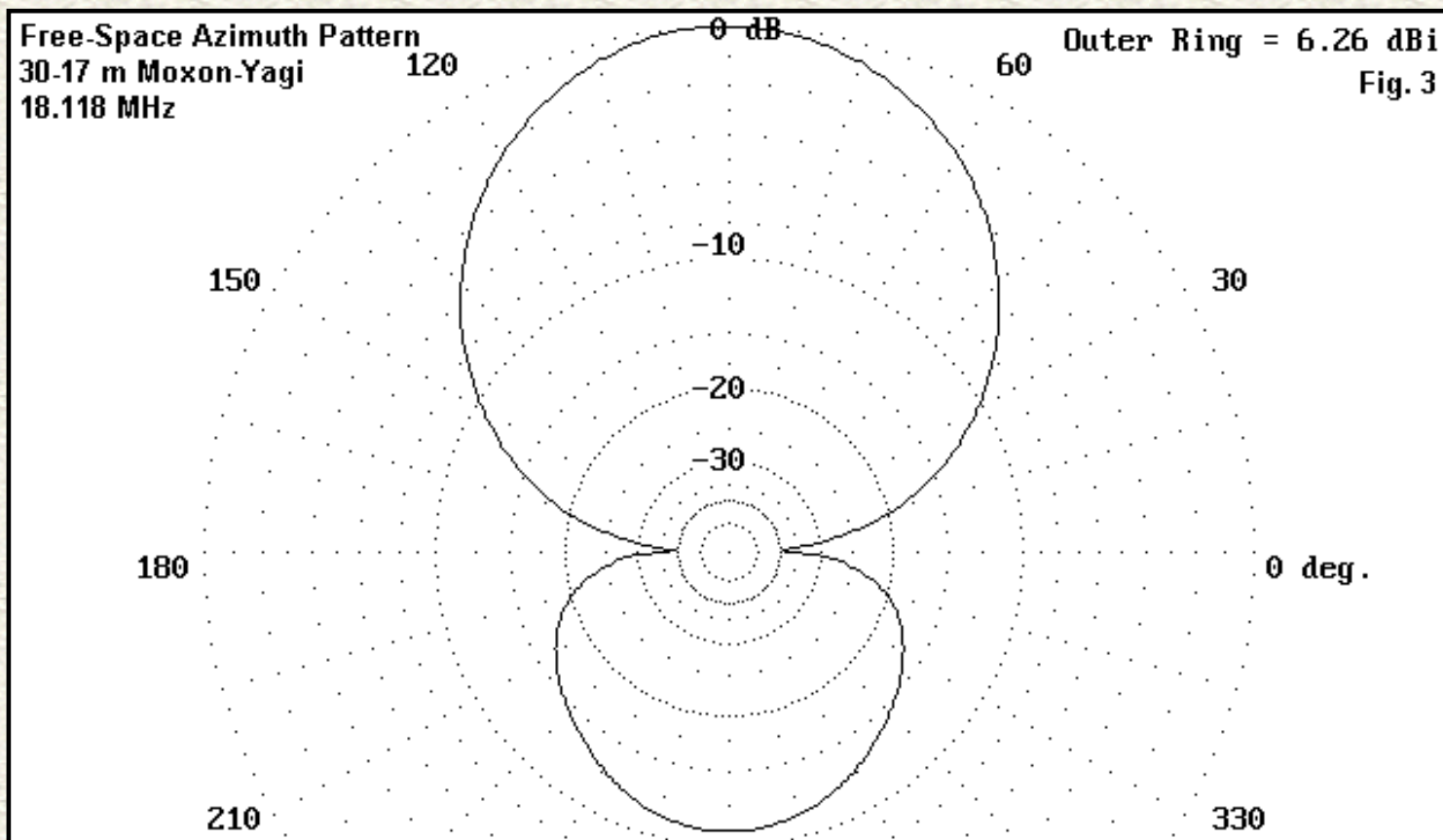

Because the upper band Yagi is behind and within the Moxon rectangle, there is no significant forward-stagger effect. Hence, the Yagi gain and front-to-back ratios are virtually identical to those one might obtain from an independent driver-reflector Yagi for 17 meters. However, with $1/8$ wavelength spacing, the feedpoint impedance of an independent Yagi would be closer to 35 Ohms. The near-50-Ohm match is obtained by virtue of the open-sleeve coupling, which can be set for virtually any desired impedance by changes in the length and/or spacing of the driver relative to the physically fed element. As we saw last month, the impedance changes more rapidly on a slaved element than on a directly fed element. In the case of the 17-meter Yagi, it is the reactance that undergoes the most rapid change, while the resistance remain quite stable.

Although the 17-meter Yagi does not gain anything from being inside the Moxon, it does not lose anything either. Moreover, it does not take up an additional space on a supporting tower. The two-band array has identically the same outside dimensions as the 30-meter Moxon itself. Except for the additional weight and wind load of the 17-meter elements, there seems little reason not to add the upper band if one seriously plans a 30-meter Moxon.

A 30-17-12 m Combination

Suppose we might be willing to extend the boom of the Moxon-Yagi from 12.6' to about 16 feet. For the additional 3.4' of boom length, we add one more band to the array--with virtually no change in the design work done so far. A driver-director Yagi with an element spacing of about 0.07 wavelength can be added ahead of the Moxon driver to arrive at a WARC 3-band array of considerable compactness. **Fig. 4** shows the general outline of the arrangement.

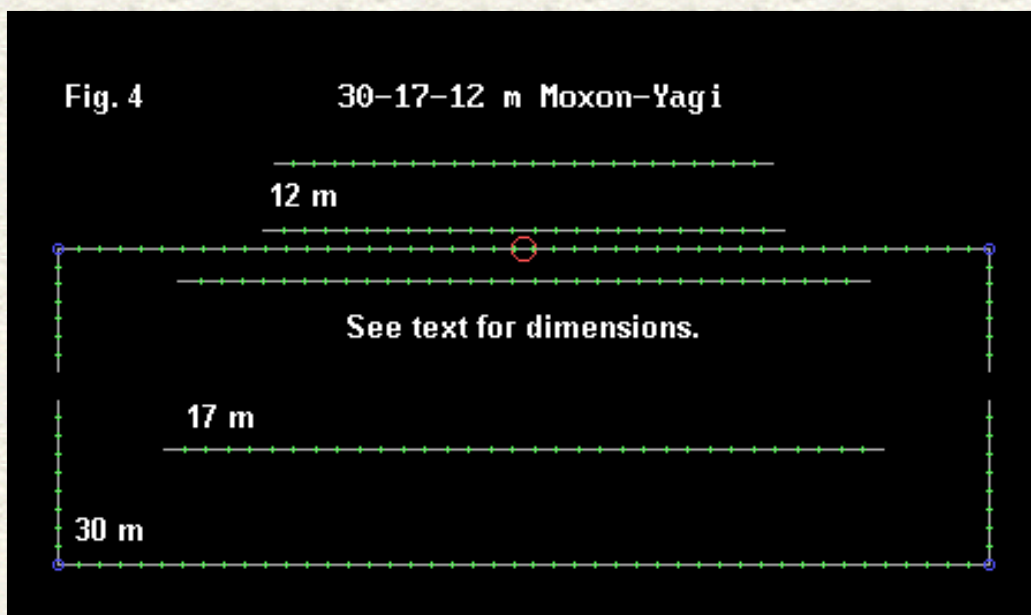

For the lower bands, the design once more uses 1.25" diameter elements for 30 and 1" diameter elements for 17. The 12-meter elements are 0.5" in diameter, and everything is aluminum. With these materials we can use the dimensions in the table below. For the 17-meter elements, the spacing entry indicates the distance behind the Moxon driver. For 12 meters, the spacing entry indicates the element spacing forward from the Moxon driver.

| Band | Dimension | Length (feet) |
|----------------|---|---------------|
| 30-meter Moxon | (all elements use 1.25" diameter aluminum tubing) | |
| Moxon | A | 34.91' |
| | B | 4.89' |
| | C | 1.12' |
| | D | 6.56' |
| | E | 12.57' |
| 17-meter Yagi | (all elements use 1.0" diameter aluminum tubing) | |
| Driver | Length | 25.80' |
| | Space | 1.30' |
| Reflector | Length | 27.00' |
| | Space | 8.00' |
| 12-meter Yagi | (all elements use 0.5" diameter aluminum tubing) | |
| Driver | Length | 19.46' |
| | Space | 0.70' |
| Director | Length | 18.70' |
| | Space | 3.43' |

For the Moxon and the 17-meter Yagi, nothing has changed. The dimensions of the 12-meter Yagi are very slightly different from those used with the 17-meter Moxon last month. However, that Moxon used elements with a smaller diameter than the 30-meter Moxon in this design. The major change is in the spacing from the Moxon to the 12-meter slaved driver--somewhat wider than in the 12-17 design.

If we see little difference in dimensions, we should also expect little difference in performance. The following performance table provides the numbers.

| Frequency | Gain | Front-to-Back | Feedpoint Z | 50-Ohm |
|-----------|------|---------------|-------------|--------|
|-----------|------|---------------|-------------|--------|

| MHz | dBi | Ratio | dB | R+/-jX Ohms | VSWR |
|--------|------|-------|----|--------------|------|
| 10.100 | 6.23 | 22.5 | | 48.5 - j 4.9 | 1.11 |
| 10.125 | 6.15 | 26.3 | | 51.7 - j 2.8 | 1.07 |
| 10.150 | 6.07 | 32.1 | | 54.9 + j 0.9 | 1.10 |
| 18.068 | 6.40 | 11.3 | | 53.3 - j16.3 | 1.38 |
| 18.118 | 6.31 | 11.4 | | 51.3 - j 1.2 | 1.04 |
| 18.168 | 6.21 | 11.4 | | 49.4 + j13.6 | 1.31 |
| 24.89 | 6.57 | 25.3 | | 59.4 - j 9.9 | 1.28 |
| 24.94 | 6.67 | 22.1 | | 48.7 + j 3.4 | 1.08 |
| 24.99 | 6.76 | 19.2 | | 38.9 + j18.5 | 1.62 |

On 30 meters, performance only shows insignificant changes in the last decimal places of the performance figures. On 17 meters, the performance values are numerically up, but again, not in a way that makes a difference that one could detect in use. The numeric increase is due in part to the forward stagger effect that gives the 12-meter elements a slight director effect during 17-meter operation.

On 12 meters, the 2-element driver-director array performs normally for an antenna of this type, although the independent feedpoint impedance of about 20 Ohms is overcome by slaving the driver to the 30-meter Moxon driver. Last month we saw higher gains on 12 meters. However, the 30-meter driver is farther removed from the 12-meter elements and provides some isolation of them from the interior 17-meter elements. Hence, forward stagger effects are minimal.

Nonetheless, for a beam with a 16' boom length, the tri-band Moxon-Yagi offers excellent potential. **Fig. 5** shows the free-space azimuth pattern at 10.125 MHz.

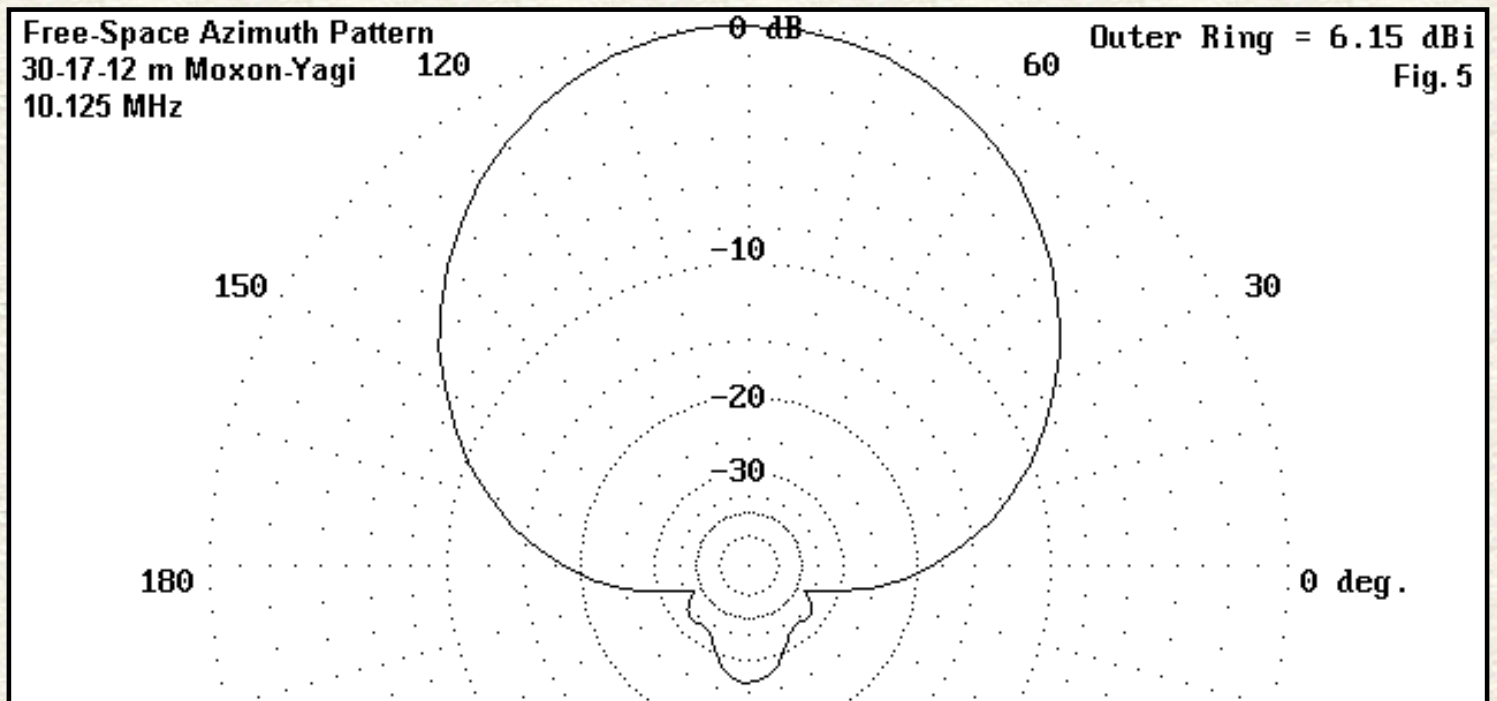

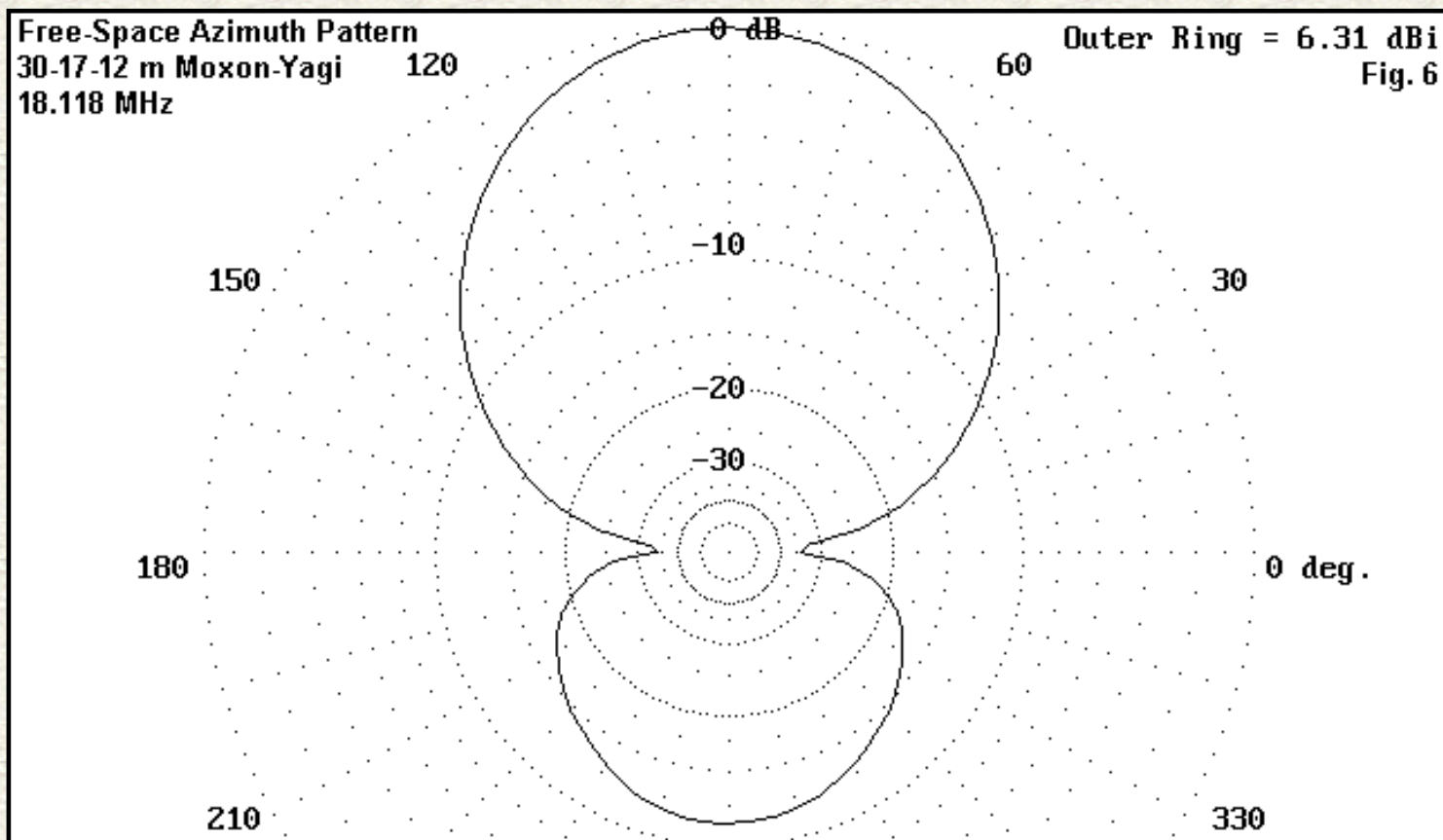

In **Fig. 6**, we see essentially the same pattern as in **Fig. 3** for the middle of 17 meters. The 12-meter free-space azimuth pattern for 24.94 MHz (**Fig. 7**) is similar to the one shown for 12 meters last month. The same rear quartering lobes are present to moderate the 180-degree front-to-back ratio.

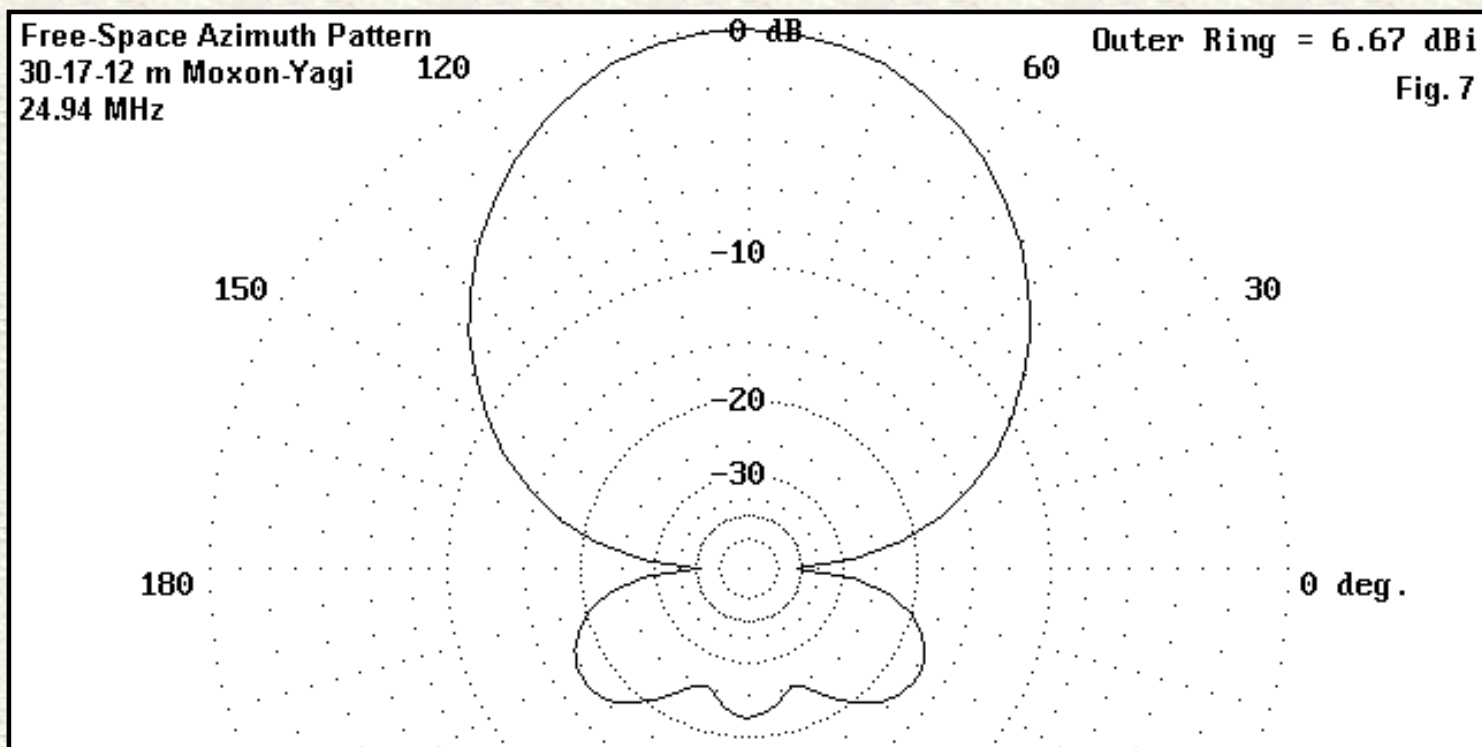

The exact spacing and length of the slaved drivers will require field adjustment to arrive at a final setting to achieve a

good 50-Ohm match on each band. However, those adjustments are about the only critical matters related to construction--once you decide on and design for the precise set of materials you will use. Essentially, you can design an independent Moxon for 30 meters and adjust it to perfection. Then, you can add the 17-meter elements and perform driver adjustments until you are satisfied. Rechecking the 30-meter impedance should show no significant change. Finally, add the 12-meter elements and adjust its driver for a good match on that band. Because element spacing is a bit more critical for driver-director arrays than for driver-reflector Yagis, recheck the element spacing for 12 meters before concluding the adjustment procedure. Once more, the impedances for 30 meters and 12 meters should not have significantly changed by adding the 12-meter elements.

I have good luck in adjusting Moxons and simple Yagis close to the ground by pointing the array as close to straight up as possible, with the reflector anywhere from 4 to 12 feet off the ground. The adjustments have held true at heights from 20 to 35 feet up. This technique is not applicable for all beams, but it is worth a try for those who do not relish adjusting beam elements from the top of a tower.

For those who wish to do further design work on models of the two antennas, here are model descriptions that should ease wire coordinate entries for most NEC modeling software.

30-17 m Moxon-Yagi Frequency = 10.125/18.118 MHz.

Wire Loss: Aluminum -- Resistivity = 4E-08 ohm-m, Rel. Perm. = 1

----- WIRES -----

| Wire Conn. | --- End 1 (x,y,z : ft) | Conn. | --- End 2 (x,y,z : ft) | Dia(in) | Segs |
|------------|------------------------------|-------|-------------------------|----------|------|
| 1 | -17.457, -4.888, 0.000 | W2E1 | -17.457, 0.000, 0.000 | 1.25E+00 | 7 |
| 2 | W1E2 -17.457, 0.000, 0.000 | W3E1 | 17.457, 0.000, 0.000 | 1.25E+00 | 45 |
| 3 | W2E2 17.457, 0.000, 0.000 | | 17.457, -4.888, 0.000 | 1.25E+00 | 7 |
| 4 | -17.457, -6.005, 0.000 | W5E1 | -17.457, -12.569, 0.000 | 1.25E+00 | 9 |
| 5 | W4E2 -17.457, -12.569, 0.000 | W6E1 | 17.457, -12.569, 0.000 | 1.25E+00 | 45 |
| 6 | W5E2 17.457, -12.569, 0.000 | | 17.457, -6.005, 0.000 | 1.25E+00 | 9 |
| 7 | -12.900, -1.300, 0.000 | | 12.900, -1.300, 0.000 | 1.00E+00 | 33 |
| 8 | -13.500, -8.000, 0.000 | | 13.500, -8.000, 0.000 | 1.00E+00 | 33 |

----- SOURCES -----

| Source | Wire Seg. | Wire #/Pct Actual | From End 1 (Specified) | Ampl.(V, A) | Phase(Deg.) | Type |
|--------|-----------|-------------------|------------------------|-------------|-------------|------|
| 1 | 23 | 2 / 50.00 | (2 / 50.00) | 1.000 | 0.000 | V |

Ground type is Free Space

30-17-12 m Moxon-Yagi Frequency = 10.125/18.118/24.94 MHz.

Wire Loss: Aluminum -- Resistivity = 4E-08 ohm-m, Rel. Perm. = 1

----- WIRES -----

| Wire Conn. | --- End 1 (x,y,z : ft) | Conn. | --- End 2 (x,y,z : ft) | Dia(in) | Segs |
|------------|------------------------|-------|------------------------|---------|------|
|------------|------------------------|-------|------------------------|---------|------|

| | | | | | | | | | | |
|----|------|----------|----------|-------|------|----------|----------|-------|----------|----|
| 1 | | -17.457, | -4.888, | 0.000 | W2E1 | -17.457, | 0.000, | 0.000 | 1.25E+00 | 7 |
| 2 | W1E2 | -17.457, | 0.000, | 0.000 | W3E1 | 17.457, | 0.000, | 0.000 | 1.25E+00 | 45 |
| 3 | W2E2 | 17.457, | 0.000, | 0.000 | | 17.457, | -4.888, | 0.000 | 1.25E+00 | 7 |
| 4 | | -17.457, | -6.005, | 0.000 | W5E1 | -17.457, | -12.569, | 0.000 | 1.25E+00 | 9 |
| 5 | W4E2 | -17.457, | -12.569, | 0.000 | W6E1 | 17.457, | -12.569, | 0.000 | 1.25E+00 | 45 |
| 6 | W5E2 | 17.457, | -12.569, | 0.000 | | 17.457, | -6.005, | 0.000 | 1.25E+00 | 9 |
| 7 | | -12.900, | -1.300, | 0.000 | | 12.900, | -1.300, | 0.000 | 1.00E+00 | 33 |
| 8 | | -13.500, | -8.000, | 0.000 | | 13.500, | -8.000, | 0.000 | 1.00E+00 | 33 |
| 9 | | -9.730, | 0.700, | 0.000 | | 9.730, | 0.700, | 0.000 | 5.00E-01 | 25 |
| 10 | | -9.350, | 3.430, | 0.000 | | 9.350, | 3.430, | 0.000 | 5.00E-01 | 25 |

----- SOURCES -----

| Source | Wire Seg. | Wire #/Pct Actual | From End 1 (Specified) | Ampl.(V, A) | Phase(Deg.) | Type |
|--------|-----------|-------------------|------------------------|-------------|-------------|------|
| 1 | 23 | 2 / 50.00 | (2 / 50.00) | 1.000 | 0.000 | V |

Ground type is Free Space

The 30-17 or the 30-17-12 combination arrays offer some interesting potentials for small WARC band beams. These design notes aim to whet your appetite for further and improved designs. However, you will have to go some to improve performance on all bands while shrinking the size of these arrays. However, if you do manage the trick, I'd be first in line to find out how.

Updated 6-1-2000. © L. B. Cebik, W4RNL. The original item appeared in AntenneX for May, 2000. Data may be used for personal purposes, but may not be reproduced for publication in print or any other medium without permission of the author.



[Go to Main Index](#)

The All-Band Center-Fed Inverted-L

L. B. Cebik, W4RNL

When I wrote on "The L-Antenna" for 10-meters a few months back, I noted that the antenna was not likely new. I have since learned that the basic idea seems to have originated with VK3AM in the early 1950s and is described in L. A. Moxon's (G6XN) classic *HF Antennas for All Locations* (pp. 154-156 of the first edition). This antenna is a standing L, although Moxon has no problems with viewing it inverted. Ralph Holland, VK1BRH, includes the L in his computer study of several antennas, including an interesting variant of the L: the 1/2 wl inverted-L. (VK1BRH's interesting modeling studies, published in *Amateur Radio*, the journal of the Australian Wireless Association, can be found at his web site: <http://www2.dynamite.com.au/vk1brh/Antsim.htm>) Perhaps the earliest article on the inverted-L as an all-band antenna may have been "The 'Inverted L' Ham Antenna," by Bob See, W5LTD, which appeared in *Radio and TV News*, January, 1959, pp. 64-65. Bob used base feeding to operate the antenna as a standard inverted-L monopole with a ground plane on 80 and as an end- or voltage-fed longer wire above 80, as his measured impedance figures attest. The 1/2 wl inverted-L can also be center-fed using parallel feedline and an ATU. We shall focus on the center-fed version: it is an antenna with excellent potential as an all-band substitute for the 135' center-fed doublet.

The 1/2 wl inverted-L which we shall examine differs from standard 1/4 wl inverted-Ls in 2 ways: First, it is longer, of course. Second, it is normally current fed at the center (although end- or voltage-feeding is always possible, even if not always convenient). Hence, it can be viewed as an inverted Vee tilted over by 45 degrees. Alternatively, it can be viewed as a 1-leg-ground-plane 1/4 wl vertical upside down.

If the upside-down vertical had a second leg going in exactly the opposite direction, the result would be--to a large degree--cancellation of the horizontally polarized radiation. Let's call this antenna the T.

Both the L and the T differ from the standard 1/4 wl ground plane vertical by being complete antennas--dipoles as it were. Hence, neither requires a ground plane beneath them. For some situations, this fact can simplify construction. The figure below shows the structural differences among the three antennas for models set at 3.7 MHz. The L and T models were set at a top height of 70', with the vertical arm terminated 4.5' off the ground.

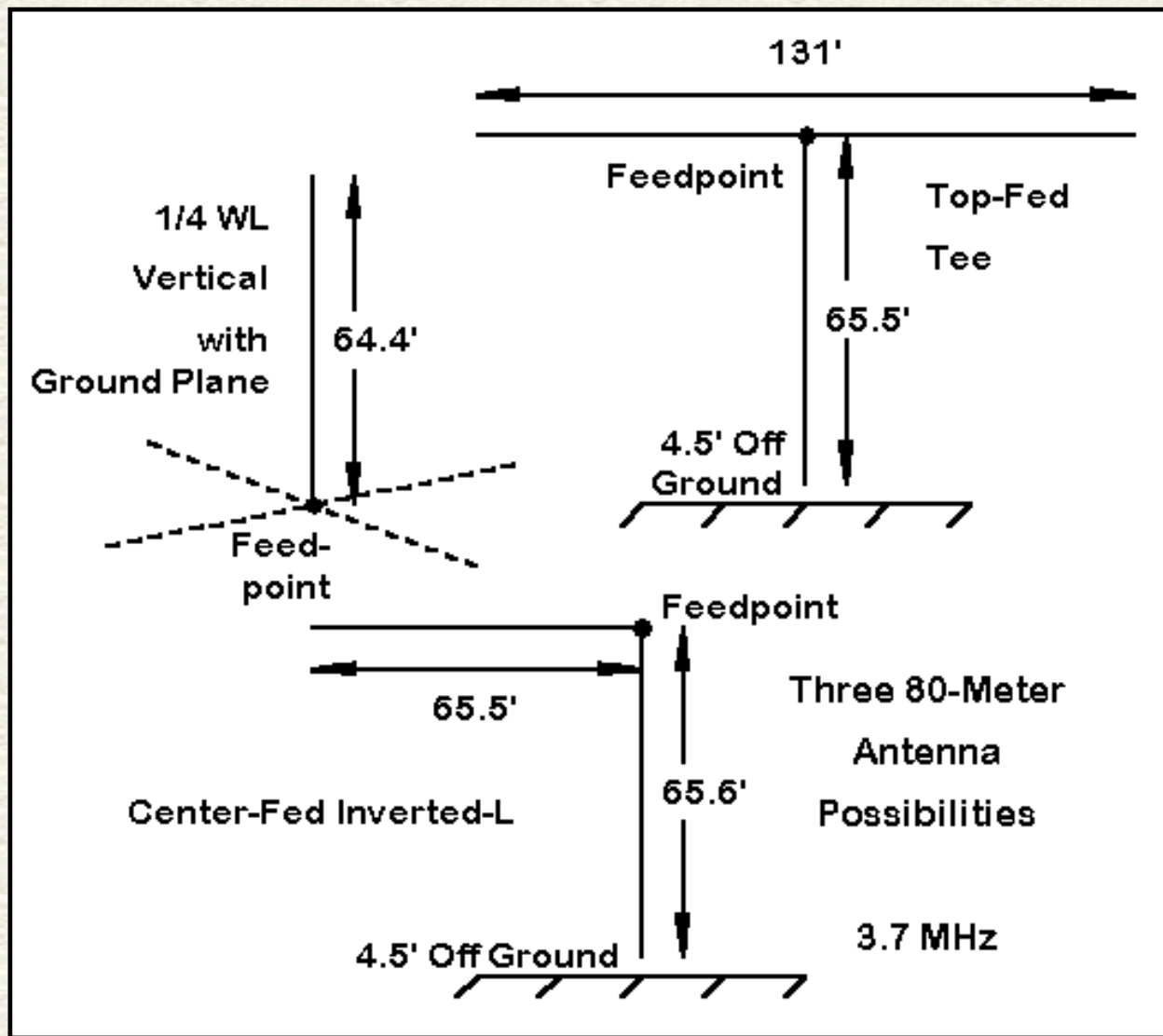

Each antenna was modeled using #14 copper wire and average ground throughout. Note that the inverted-L and the T present challenges to the builder in terms of routing the parallel feedline to the top feedpoint. We shall do some comparisons, but first, let's become a bit more familiar with the inverted-L basic pattern.

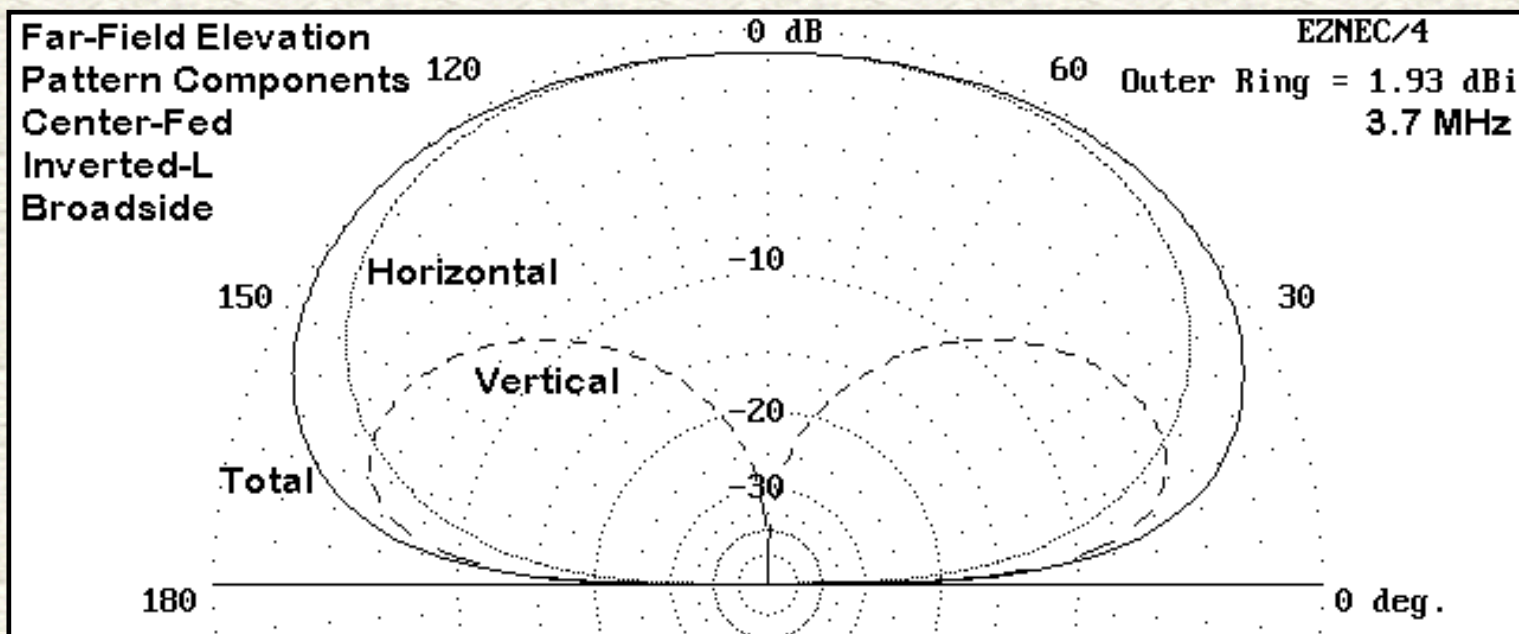

The elevation pattern above shows the vertical, horizontal, and total field components of the inverted-L radiation pattern taken broadside to the horizontal arm of the antenna, where radiation is strongest. In the plane off the ends of the horizontal arm, horizontally polarized radiation is somewhat weaker, but the vertically polarized radiation remains at full strength, with some pattern bending away from the horizontal arm.

A fair comparison might be made among elevation patterns for the L, T, and vertical. Since the total pattern of the L is a broad oval, let's take the strongest direction also of the T, which happens to be off the ends of the horizontal arms. The vertical is truly omnidirectional, so let's set at least 20 radials beneath it.

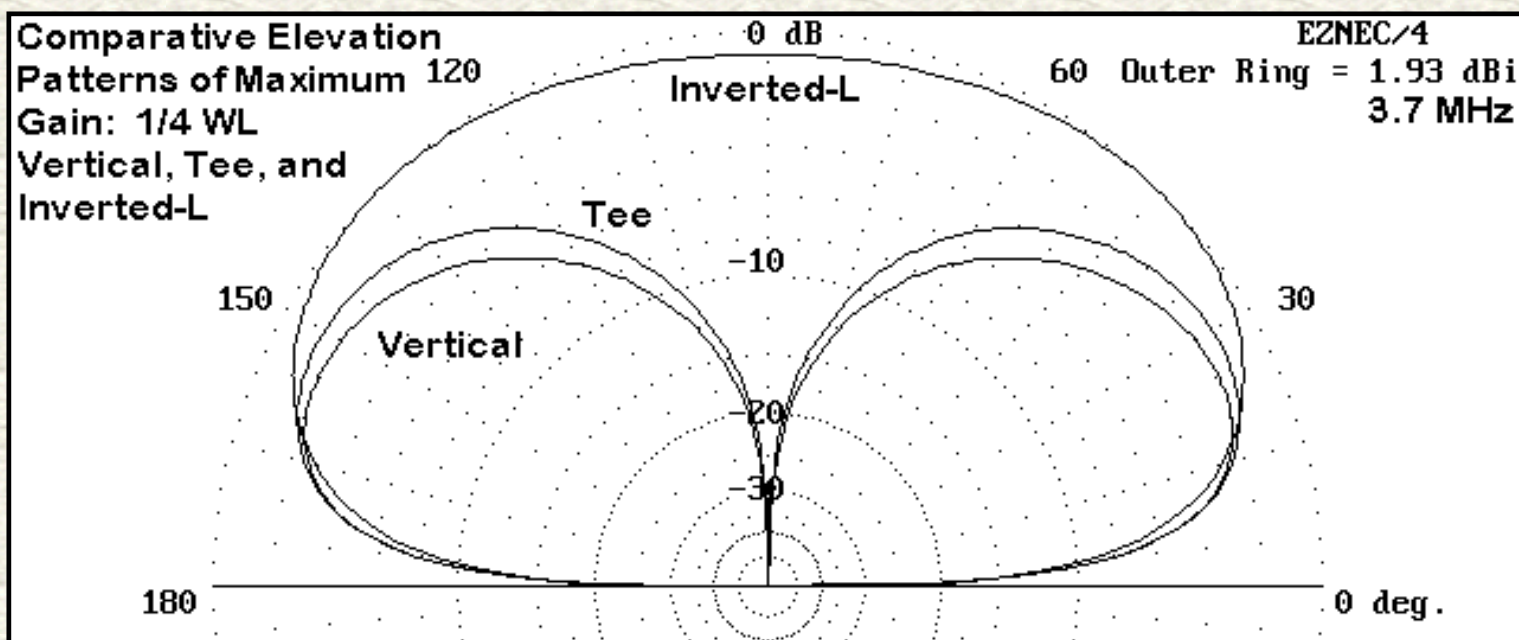

The comparative pattern above shows the rough equality of the T and the ground-plane-vertical patterns under the specified conditions. Surprisingly, the inverted-L comes close to both antennas in low angle radiation. It also has stronger high angle radiation--without becoming a cloud burner--which is useful for shorter skip contacts. In other words, the inverted-L has potential as an all-purpose low-band antenna.

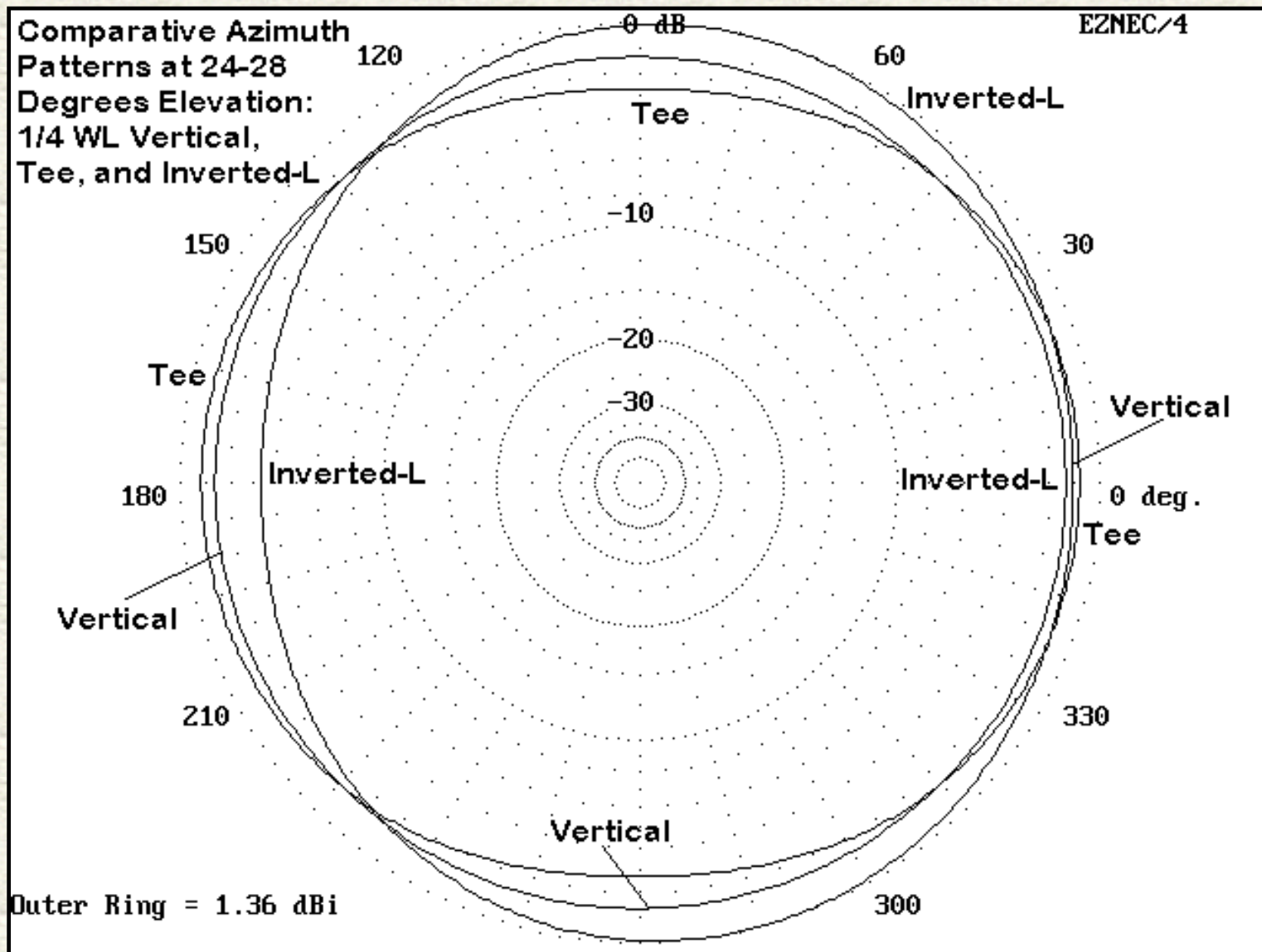

The azimuth patterns of the three antennas--taken at elevation angles between 24 and 28 degrees--show the slight oval of the T and the slightly more radical oval of the inverted-L. The L's azimuth pattern also shows the slight displacement in the direction away from the horizontal arm. However, these effects are small enough not to stand in the way of using the antenna for general operating purposes.

The Ground-Plane Question

In principle, as a complete $1/2$ wl antenna, the inverted-L requires no ground plane. Likewise, the T should require none. In contrast, the $1/4$ wl vertical requires a ground plane to complete the antenna. To test the relative need and utility of a ground plane, I modeled all three antennas with ground planes, first using 4 wires and then using 20 wires. I set each ground plane first at 1' below ground, then at the surface, and finally at 1' above ground. The vertical's source segment touches the ground, which gives erroneous results in NEC-4. Therefore, the surface ground plane for the vertical was set 0.1' above ground. The radial wires were the same length as the vertical radiators, which means slightly shorter radials for the vertical than for the L or T.

The following table summarizes results for the three antennas with 4 and 20 wire ground planes.

| Antenna/GP level | Gain dBi | TO angle degrees | Source Impedance R +/- jX Ohms |
|------------------------|-------------|---------------------|-----------------------------------|
| 4-radial tests | | | |
| Inverted-L | | | |
| No GP | 1.93 | 44 | 66.1 + j 3.8 |
| GP -1' | 1.97 | 45 | 66.1 + j 4.5 |
| GP 0' | 1.96 | 44 | 66.0 + j 4.0 |
| GP +1' | 2.03 | 46 | 65.6 + j 4.5 |
| T | | | |
| No GP | 0.56 | 28 | 42.7 - j 5.2 |
| GP -1' | 0.61 | 28 | 42.7 - j 4.6 |
| GP 0' | 0.60 | 28 | 42.7 - j 5.0 |
| GP +1' | 0.58 | 28 | 42.3 - j 5.2 |
| Vertical | | | |
| No GP | -0.78 | 24 | 48.2 + j 0.2 |
| GP -1' | -2.38 | 25 | 68.5 + j 8.1 |
| GP 0' | -0.79 | 25 | 45.5 + j32.5 |
| GP +1' | -0.21 | 24 | 39.6 - j 9.3 |
| 20-radial tests | | | |
| Inverted-L | | | |
| No GP | 1.93 | 44 | 66.1 + j 3.8 |
| GP -1' | 2.11 | 45 | 65.4 + j 6.5 |
| GP 0' | 1.99 | 44 | 66.3 + j 4.4 |
| GP +1' | 2.10 | 46 | 64.5 + j 4.7 |
| T | | | |
| No GP | 0.56 | 28 | 42.7 - j 5.2 |
| GP -1' | 0.81 | 28 | 41.9 - j 3.0 |
| GP 0' | 0.65 | 29 | 42.9 - j 4.7 |
| GP +1' | 0.62 | 28 | 41.3 - j 5.2 |
| Vertical | | | |
| No GP | -0.78 | 24 | 48.2 + j 0.2 |
| GP -1' | -0.47 | 25 | 45.3 - j 0.9 |
| GP 0' | 0.02 | 24 | 37.1 - j 3.9 |
| GP +1' | 0.06 | 24 | 36.8 - j14.6 |

Although the tables give the most data, comparisons are more difficult than with a graph.

L, T, and Vertical Gains Various Ground Planes

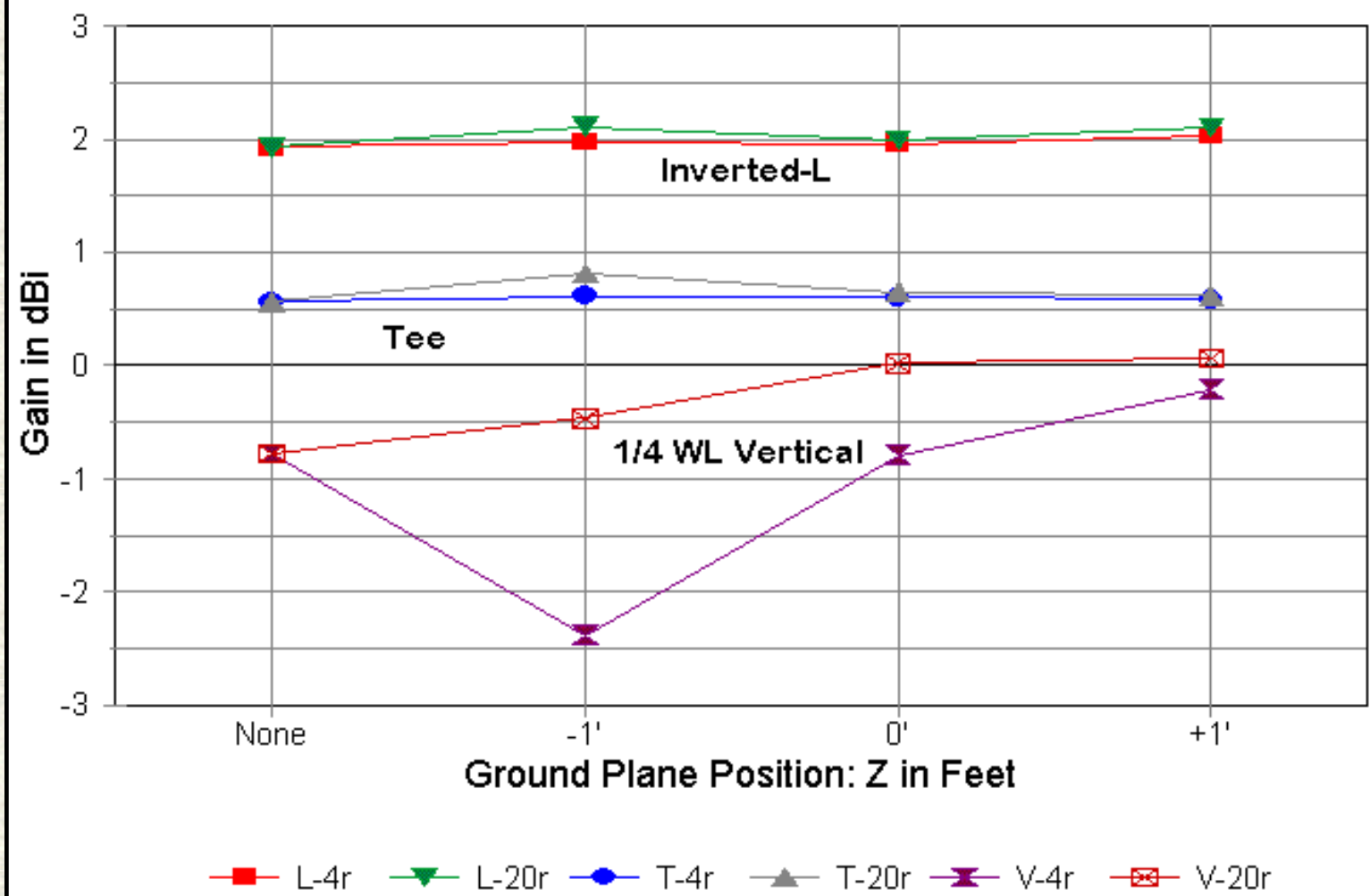

The antenna gains are compared in the graph above. The line connections between points are not real connections, but only let the eye tell which data points go together. As is evident, NEC-4 modeling strongly suggests that the addition of a ground plane adds virtually nothing to antenna performance for the inverted-L and the T, both of which we have described as complete antennas. In contrast, the vertical is dependent upon the most extensive (up to 60-100 radials) that a builder can install. (The vertical antenna data point for "No Ground Plane" should be used for reference and does not represent accurate data relative to a real antenna.) I further modeled the vertical with 64 radials. At a depth of 1', the antenna gain increased to 0.19 dBi, while setting them 1' above ground yielded a gain of 0.02 dBi. Modeling has consistently suggested that for perfectly symmetrical ground planes above ground, more than 6-8 radials may be superfluous. This conclusion does not necessarily apply to ground planes that are not perfectly symmetrical.

An alternative to high-altitude center feeding of the inverted-L is to base feed it at the low end of the vertical. Models of this mode of feeding the antenna show patterns quite consistent with those for center feeding, with a source impedance in the neighborhood of 5000 Ohms. Once more, the addition of a ground plane does not aid antenna performance in any way, as the following elevation plot shows.

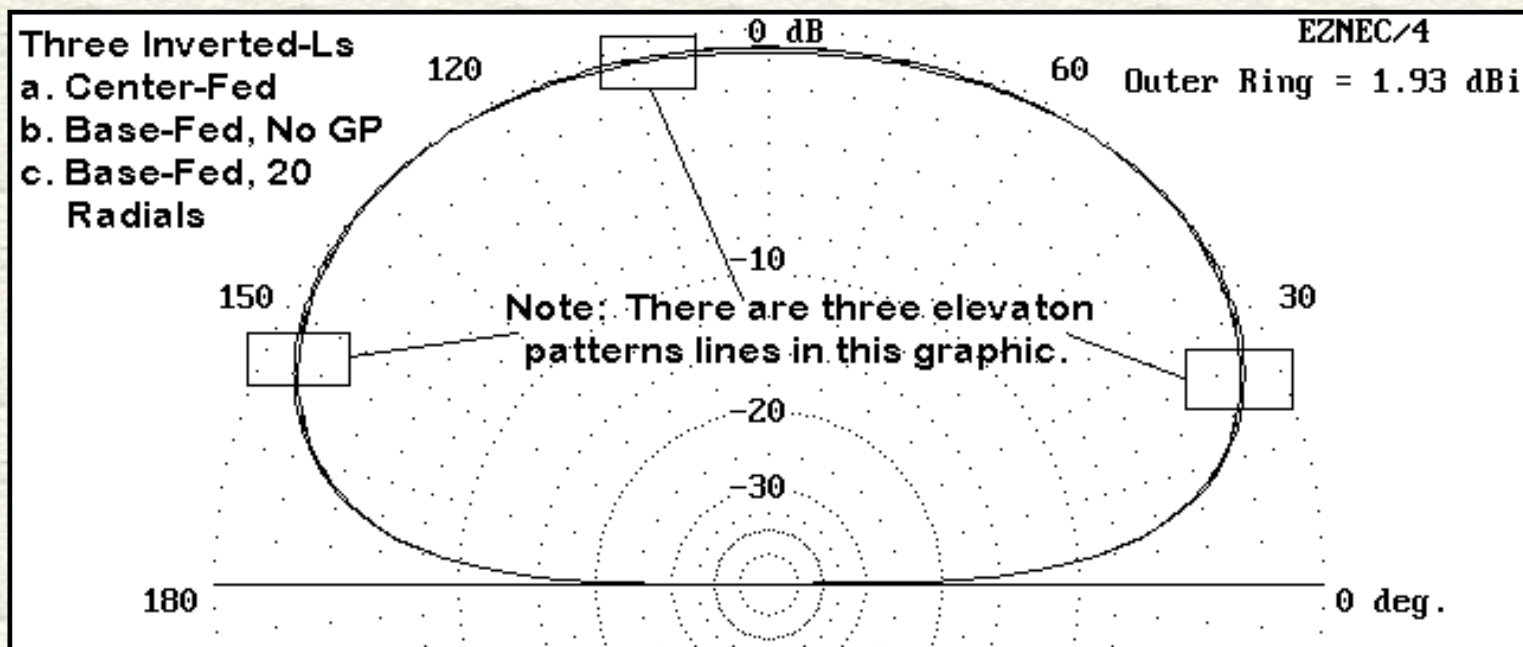

However, the absence of need for a ground plane should not be mistaken for an absence of a need for a good RF ground. In turn, we should not presume that the ground rod near the shack, which provides AC and DC power grounding for safety, also provides an adequate RF ground. Army tests established a couple of decades ago that a good RF ground needs periodic short (<2') rods connected by a perimeter wire or strap that essentially surrounds the entire station location.

Installation Variations

Knowing that not everyone tempted to use the inverted-L will have all of the space needed, I checked some variants that represent typical construction compromises or changes. Since the antenna will be fed with parallel transmission line, matching is not a major problem. However, changes of gain and elevation angle may indicate that some variations are better than others.

1. Height: elevating the inverted-L is a route to slightly more gain and a lower take-off angle broadside to the horizontal arm. Here is a table of values modeled with top heights at every 5' from 70 to 100 feet up.

| Top Ht. feet | Bottom Ht. feet | Gain dBi | TO Angle degrees | Feed Impedance R +/- jX Ohms |
|-----------------|--------------------|-------------|---------------------|---------------------------------|
| 70 | 4.5 | 1.93 | 44 | 66.1 + j 3.8 |
| 85 | 9.5 | 2.20 | 42 | 62.8 - j 4.2 |
| 80 | 14.5 | 2.43 | 41 | 60.1 - j 9.3 |
| 85 | 19.5 | 2.63 | 38 | 57.6 - j12.8 |
| 90 | 24.5 | 2.83 | 37 | 55.3 - j15.4 |
| 95 | 29.5 | 3.02 | 34 | 53.0 - j17.2 |
| 100 | 34.5 | 3.22 | 33 | 50.9 - j18.5 |

Nothing drastic happens between any two levels, but the trends are clear. Gain increases and take-off angle decreases. The antenna plays shorter, the higher we go. However, unless one plans to use a monoband coax feed system, the precise dimensions are not at all critical.

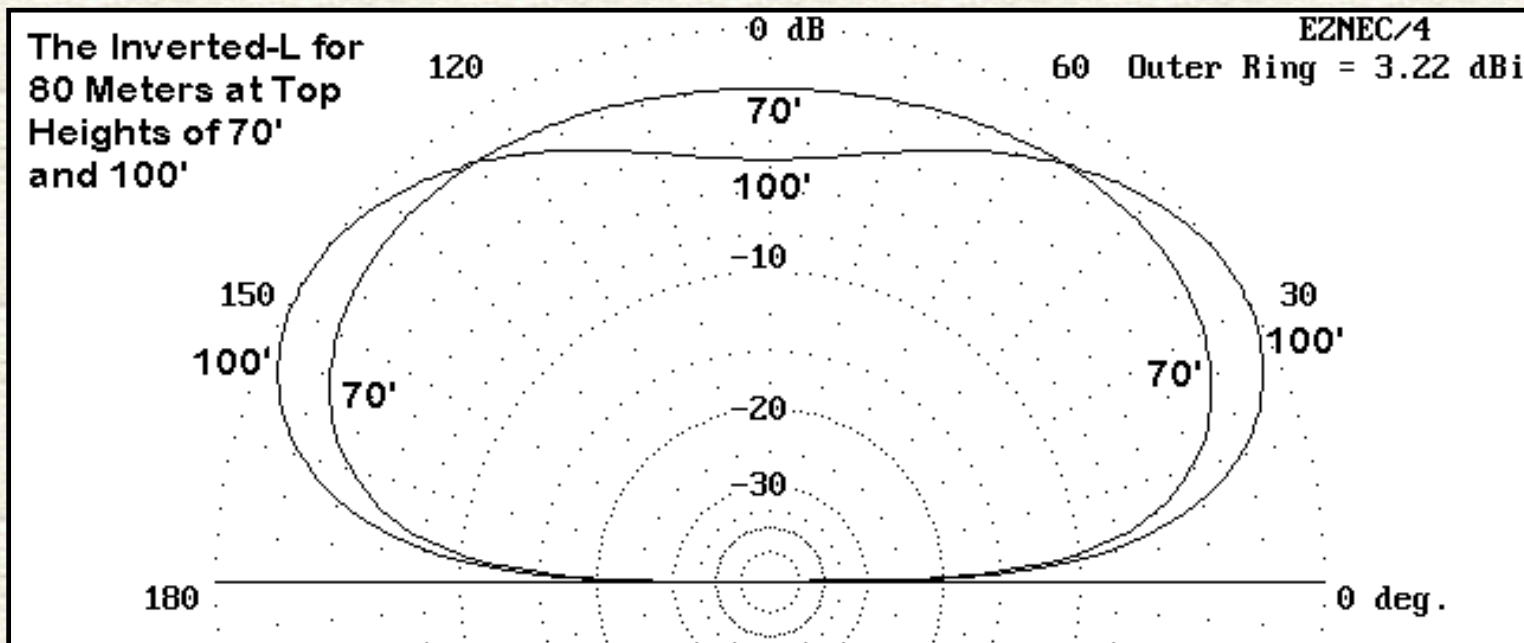

The elevation patterns in the figure compare the antenna at 70' and at 100' and add visual confirmation of the conclusion drawn from the table.

2. Sloping and Bending: The more normal problem for home installation is too little vertical or horizontal space. As the figure below shows, there are a number of installation "tricks" we might use. The question at hand is how much each will hurt performance.

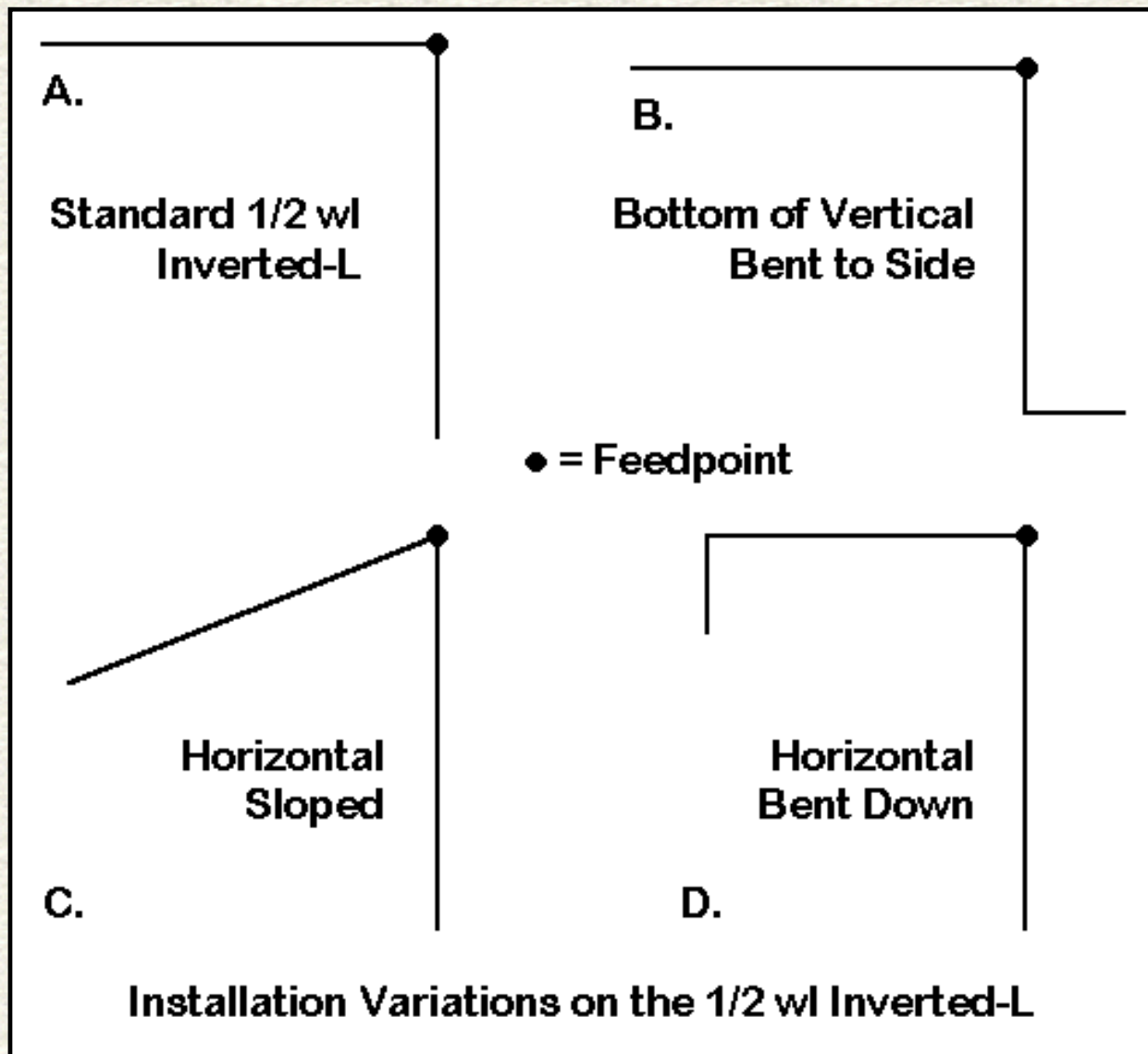

Bending the vertical at the bottom: The first way to save vertical space or to protect family members from the high voltage at the antenna element end is to bend the lower end of the vertical to the side. The upper horizontal arm remains 65.5' long. The overall length of the vertical is also 65.5', but part is now vertical and part horizontal. I tested three scenarios, listed in the table below:

| Max. Ht feet | Vert. Wire feet | Low Hor. feet | Gain dBi | TO Angle degrees | Feed Impedance R +/- jX Ohms |
|-----------------|--------------------|------------------|-------------|---------------------|---------------------------------|
| 70 | 60 | 5.5 | 2.04 | 45 | 64.2 - j 4.4 |
| 70 | 55 | 10.5 | 2.22 | 47 | 61.8 - j11.3 |
| 65 | 55 | 10.5 | 1.92 | 49 | 64.8 - j 2.7 |

The chief effect of the bend is to raise the high angle radiation strength a small bit and to raise the elevation angle of maximum radiation. The latter figure indicates a slight loss in the lowest angle radiation, which one would anticipate from shortening the vertical length. None of these small changes in dimension affect the usability of the antenna.

Sloping the horizontal arm down: One might wish to use the antenna where there is only one truly tall support and the support for the far end of the horizontal arm is lower. The result is a sloping horizontal arm. Using a peak height of 70' and keeping the dimensions of each wire at 65.5', I tested 2 scenarios, representing two degrees of slope, against the

standard installation.

| Max. Vert Ht feet | Hor. End Ht feet | Gain dBi | TO Angle degrees | Feed Impedance R +/- jX Ohms |
|----------------------|---------------------|-------------|---------------------|---------------------------------|
| 70 | 70 (no slope) | 1.93 | 44 | 66.1 + j 3.8 |
| 70 | 60 | 2.26 | 51 | 58.6 + j 8.4 |
| 70 | 50 | 2.66 | 58 | 52.4 + j32.0 |

Gain increases are at high angles of radiation, with some loss of low angle radiation strength. Although a true horizontal is perhaps the best compromise for maximum low and high angle performance, the patterns with a modest slope to the horizontal arm do not make the antenna unusable by any means.

Bending the horizontal arm far end down: If horizontal space is limited, a common practice is to bend (or dangle) the outer ends of a dipole downward. since the region is the high voltage and low current portion of the antenna, the radiation pattern is least affected by modifying the geometry. Again, I compared 2 scenarios to the full length horizontal arm configuration.

| Max. Ht feet | Hor. Arm Lth feet | Bent Length feet | Gain dBi | TO Angle degrees | Feed Impedance R +/- jX Ohms |
|-----------------|----------------------|---------------------|-------------|---------------------|---------------------------------|
| 70 | 65.5 | 0.0 | 1.93 | 44 | 66.1 + j 3.8 |
| 70 | 55.5 | 10.0 | 1.82 | 45 | 62.7 - j 5.9 |
| 70 | 45.5 | 20.0 | 1.62 | 43 | 54.6 - j12.2 |

Low angle radiation remains essentially constant, since the vertical arm has not been altered. Further shortening of the horizontal arm would show a gradual further reduction in maximum gain and in the take-off angle. Higher-angle radiation is decreased, although the antenna remains eminently usable.

Like many wire antennas, the inverted-L will tolerate moderate alterations of geometry to fit the space available and still yield good, if not peak, performance.

Multi-Band Use of the Inverted-L

One disadvantage of the 135' horizontal doublet when used on the upper HF bands is that the pattern breaks into a collection of fairly narrow lobes with deep nulls between them. Since the nulls change position from band- to-band, the user is often surprised to discover that signals from certain directions are weaker than expected.

The inverted-L, when fed with parallel transmission line and an antenna tuner, is not wholly exempt from this phenomenon. However, since one arm is fully vertical, the nulls tend to be much shallower. At the same time, gain peaks are less pronounced.

The following table provides a rough guide on what to expect from each of the amateur HF bands:

| Frequency MHz | Gain dBi | To angle degrees | Feed Impedance R +/- jX Ohms | Pattern Shape (approximate) |
|------------------|-------------|---------------------|---------------------------------|--------------------------------|
| 3.7 | 1.93 | 44 | 66 + j 4 | Broadside oval |
| 7.1 | 4.09 | 26 | 6500 + j 300 | Broadside oval |
| 10.1 | 4.04 | 20 | 150 - j 500 | Square |

| | | | | |
|------|------|----|--------------|---------|
| 14.1 | 5.38 | 14 | 2000 + j2300 | 4 lobes |
| 18.1 | 6.99 | 33 | 165 - j 255 | Square |
| 21.2 | 6.74 | 9 | 750 + j1400 | 6 lobes |
| 24.9 | 6.63 | 8 | 210 - j 520 | 6 lobes |
| 28.5 | 7.55 | 7 | 575 + j1000 | 8 lobes |

Even harmonics of the antenna's fundamental frequency show high impedances, in some cases with a high reactive component. The WARC bands show more moderate impedances at the antenna feedpoint. Use of 450-Ohm or 600-Ohm parallel feedline is recommended in order to provide reasonable values of impedance at the antenna tuner terminals. As with all such antennas, if a tuner seems unable to effect a match on a given band, adding a short section of feedline between the existing line and the tuner output terminals will often correct the situation.

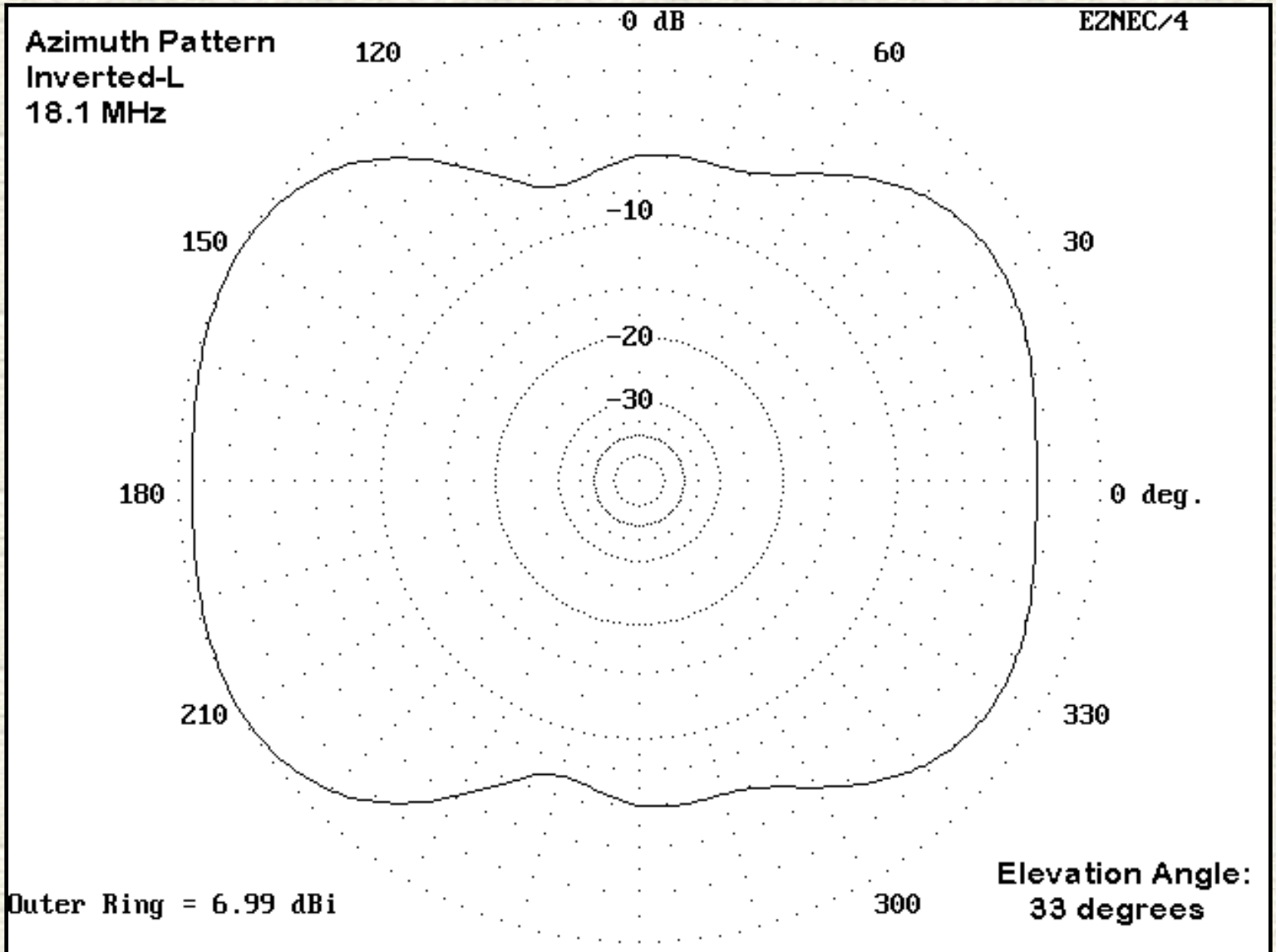

The annotation "square" to describe the azimuth pattern is illustrated by the 18.1 MHz pattern. On this band, the strongest signal occurs at the second elevation lobe. There is a usable but less strong lobe at about 16 degrees elevation. Note the absence of sharp nulls and lobes.

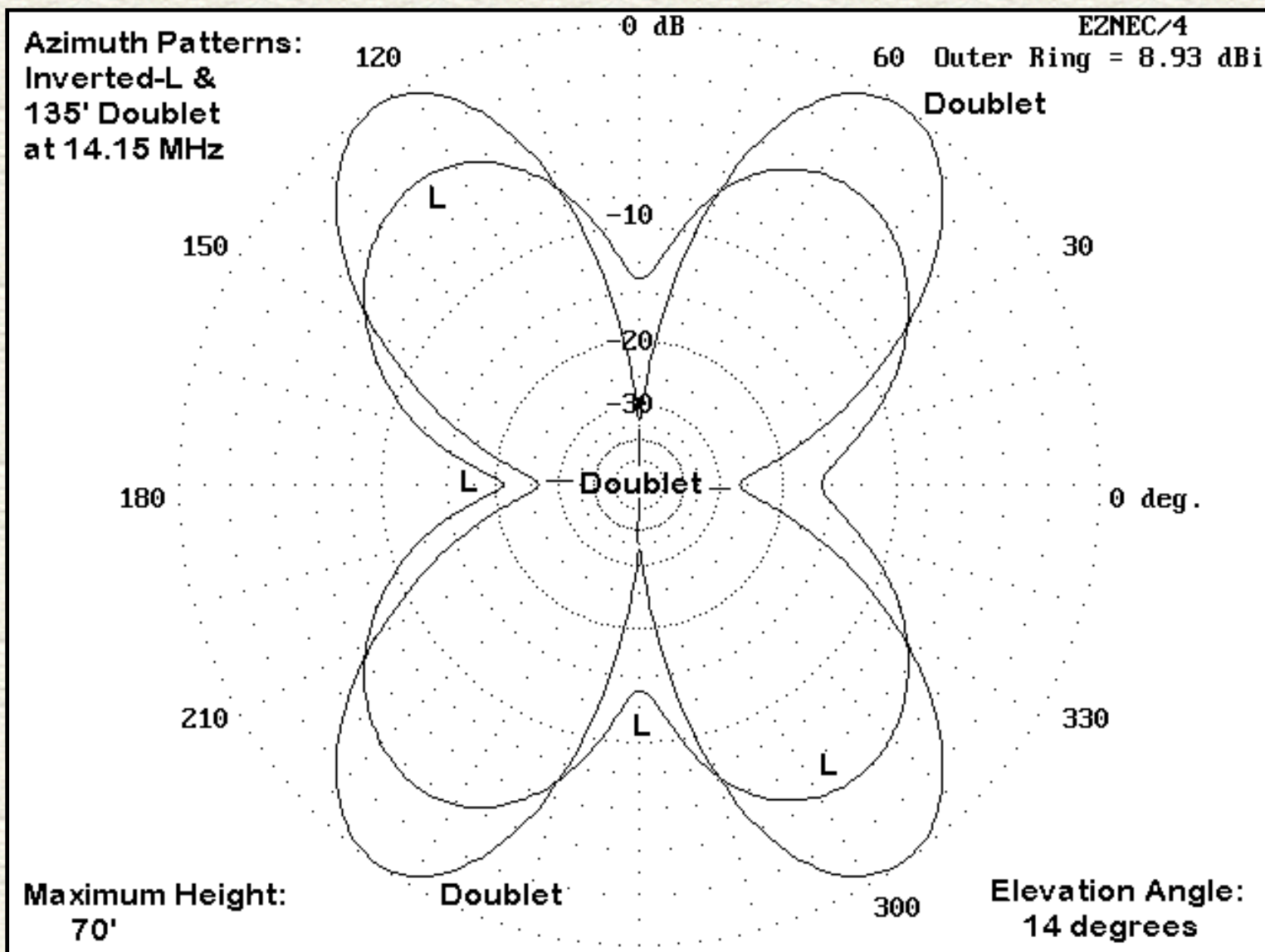

Even where lobes and nulls do occur, both are much less pronounced than they are with a standard doublet. The figure shows the differences for the 20-meter band. Doublet nulls exceed -25 dB relative to the lobes, whereas inverted-L nulls are under -10 dB relative to the lobes, which are also broader than those of the doublet. Of course, peak gain of the lobes is about 4 dB less than for the doublet lobes. For some types of operation, but certainly not for all, the absence of strong nulls can be more advantageous than a few extra dB of gain in very specific directions.

The 100' Center-Fed Inverted-L

Many hams who cannot erect a full 135' long inverted-L can often manage a 100' version of the antenna. This length would require 50' of horizontal run and about 55' of height to place the vertical section at least 5' off the ground. As we have seen, higher installations will yield better results, but the present values will provide a kind of worst-case scenario for modeling that antenna. Since the sketches for this shortened version of the inverted-L, which is about 70% full size at 80 meters, would be the same as those for longer versions, we can jump directly to a table of values for multi-band use of the antenna.

| Frequency MHz | Gain dBi | To angle degrees | Feed Impedance R +/- jX Ohms | Pattern Shape (approximate) |
|------------------|-------------|---------------------|---------------------------------|--------------------------------|
| 3.7 | 1.32 | 51 | 30 + j 425 | Broadside oval |

| | | | | |
|------|------|----|--------------|----------------|
| 7.1 | 3.13 | 31 | 305 + j1010 | Broadside oval |
| 10.1 | 4.95 | 24 | 2150 - j3100 | Broadside oval |
| 14.1 | 4.64 | 19 | 120 - j 185 | Square |
| 18.1 | 5.51 | 34 | 965 + j1785 | 4-Leaf clover |
| 21.2 | 5.00 | 12 | 475 - j1300 | 4-Leaf clover |
| 24.9 | 6.07 | 10 | 160 + j 95 | 6 lobes |
| 28.5 | 7.03 | 9 | 1775 + j1990 | 6 lobes |

As one might expect, the shorter antenna breaks into multiple lobes more slowly with increases in frequency. Moreover, the pattern of high and low feedpoint impedances differs greatly from the pattern for the 135' version. Given the lower top height, the elevation angles of maximum radiation are somewhat higher, especially on the lowest bands of operation. (Note that the band on which an unexpected high angle of maximum radiation occurs for both versions also shows a lobe of nearly the same strength at a lower angle--just about 20 degrees lower. Hence, useful radiation occurs on that band--in this case 17 meters.) Shorter antennas--down to about 90' overall wire length can be built and used on 80 meters. Below about 90' overall wire length, the antenna becomes essentially a 40-meter-and-up inverted-L.

Conclusion

The center-fed inverted-L has the potential to be a quite satisfactory all-band wire antenna suited to certain environments. The length can be almost anything about $\frac{3}{8}$ wl or longer for the lowest frequency of intended operation. Although the overall gain will be lower for each band than the gain of a horizontal doublet using the same overall wire length, the elevation angle of maximum radiation for the L will be lower than for a doublet with the same top height.

There is little evidence, despite the vertical position of one arm of the antenna, that the inverted-L would benefit from a ground plane beneath the antenna. The actual low-angle gain of the inverted-L will, however, vary with the quality of the soil in the region of reflection at a distance from the vertical arm. All patterns were taken over average soil, and soils that are either poor or better than average will tend to show a higher gain and lower take-off angle, at least on the fundamental frequency.

The electrical lineage of the center-fed inverted-L is from the dipole by way of the inverted-Vee. For the amateur yard that is short on horizontal space but long on tall supports, the inverted-L may be the antenna of choice as an all-band wire--whether used as the primary station antenna or as the back- up for more complex arrangements.

Updated 3-6-99, 3-14-99, 6-14-99. © L. B. Cebik, W4RNL. This item first appeared in AntenneX, Feb., 1999, and has been revised to include later data. Data may be used for personal purposes, but may not be reproduced for publication in print or any other medium without permission of the author.



[Return to Amateur Radio Page](#)

**BUILD THIS MULTIBAND FAN DIPOLE
FOR ALL BAND HF EXCITEMENT**

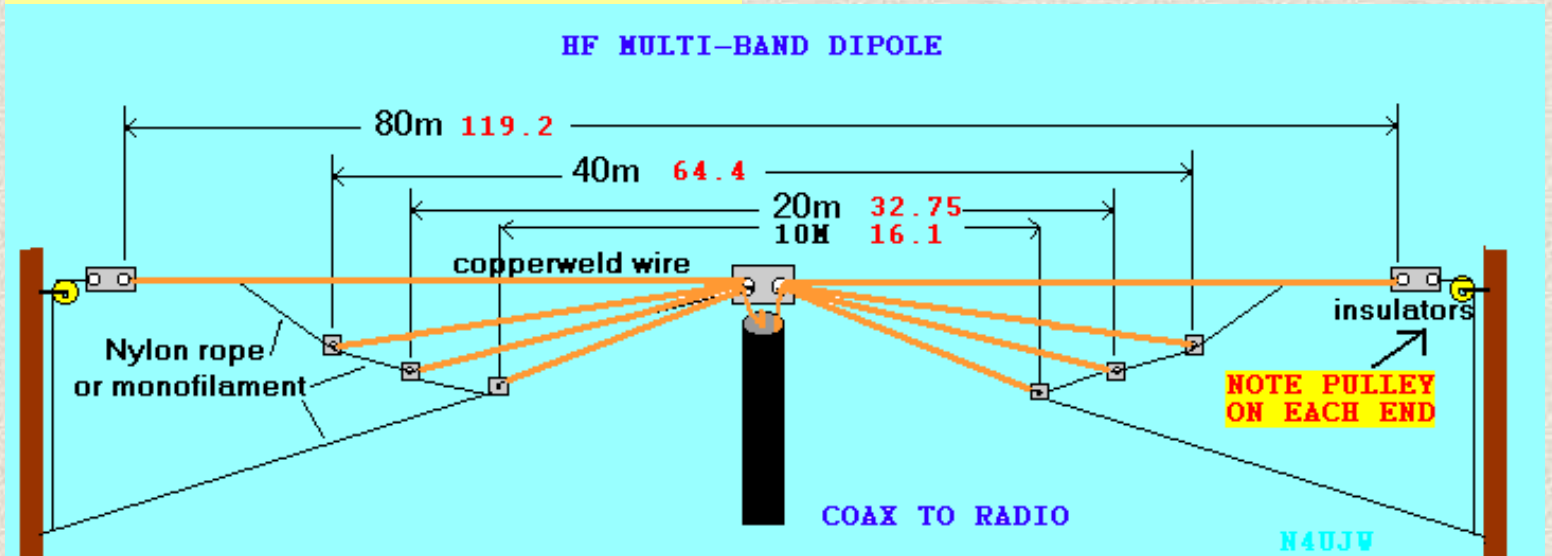

Here is a simple and easy to build multi band horizontal fan dipole that can be constructed for all band operation from 160 meters up thru 6 meters or even higher.

In the drawing above, it is shown for just four bands, 80 thru 10. One separate dipole for each band needed. However you can build it to suit your own preferences by using the standard formula for a dipole:

$468/\text{freq mhz} = \text{total length for each band}$. Use the formula for your desired center frequency.

Each dipole length above in **RED is in feet and tenths of a foot for the center of the General portion of each band** and is derived from the above formula and should be cut a little longer for swr trimming. **USE #12 TO #14 GAUGE COPPERWELD WIRE IF POSSIBLE** or use what you have on hand.

Start with your lowest (in frequency) band of operation as the main (top) support for the entire setup. Cut it per the formula and a little longer. Try to use a wire size that will support the other dipoles. This is the main support for all the other dipoles and must carry their weight.

Cut a dipole for each band of operation.

Cut each full length in half....example: for the 10 meter length from the formula you get 16.1 feet for the total length. Cut it in half equaling approx 8 feet per side. Make sure you cut each length about a foot or more longer for swr trimming and attaching to center and end insulators!

If you are building the four band dipole above, you should have 8 lengths of wire scattered all over your work area.

WARNING!

DON'T DO IT IN YOUR LIVING ROOM, THE XYL WILL NOT BE VERY HAPPY WITH YOU AND AFTER SHE GETS FINISHED WITH THE QRM,,,, ALL YOUR ANTENNA BUILDING WILL HAVE TO BE DONE FROM THE DOG'S HAM SHACK! HI!

It is assumed that you have your end support poles, trees, center and end insulators, pulleys all ready to go before you start working on the actual dipoles.

A very important part of this design is the installation of the pulleys (in yellow on drawing) on each end attached to each side support.

They are added to this design due to the swr trimming process and make it very easy to pull the entire antenna up and down while making the swr adjustments. Mount a suitable size pulley on each end attached to your pole, trees, etc for the diameter of cord or rope used to support the system.

Start your antenna trimming with the top dipole.... attach your coax to the center insulator leaving several inches of the center conductor and shield exposed. Each half of each dipole will be connected to the coax center pigtail and the shield separately. In other words,

connect one side of the dipole to the center conductor and the other side to the shield.

Attach the other end of each half of the longest wire to the support cord and run thru the pulley on each end and pull the dipole up into the air between the end supports. Check swr.

Trim as needed with low power for lowest swr possible, lower with pulleys, attach the next highest band dipole electrically to the same point as the first dipole,, raise it to operating height, check swr,,lower for trimming, up and down, up and down.....due the same for all other dipoles for each higher band of operation.

When you are finished with the highest band of operation, pull the entire system up with the pulleys and tie of at the bottom securely.

Make certain that the coax center conductor is attached to one half of each dipole and the shield to the other half. All dipole ends at center insulator are connected together.

This may not be very clear to the new antenna builder so please see the drawing below for the center insulator arrangement.

The white areas in the drawing above are mechanical supports, clamps, wire ties or whatever your genius can come up with to support the main (top wire) and the weight of the coax.

Remember, all the weight of this antenna system is supported by the top wire.

The connections should be soldered and all should be sealed including coax end from water, ice, snow etc. Use a 1:1 balun like the "[Ugly Balun](#)" project page on this site close to the center before coax goes to your rig.

For best performance get it as high as possible and remember that since this is a dipole arrangement, it will be somewhat bi-directional towards and away from you as viewed in the drawing. (BROADSIDE)

Remember that all elements will interact with each other in the tuning process and the final setup must be secured so the angle or distance between each dipole does not change when blowing in the wind, etc

The angle or distance between each dipole is not critical but the final spacing must be maintained!

It will take lots of work (trial and error) in getting each dipole to the lowest SWR. Just keep TRYING.

It should also be noted that the antenna can be used in an inverted v fashion but remember the spacing should be secure in the final operating position. Tune it as in all the above instructions.

You may use a tuner with this antenna un-trimmed to save a lot of work!

EXPERIMENT! EXPERIMENT! EXPERIMENT!

[BACK TO ANTENNA LAB](#)

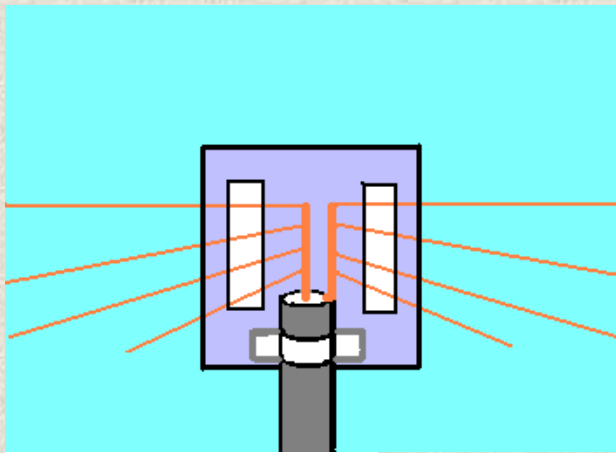

<<Little gray boxes are insulators>>



HAMUNIVERSE.COM

Your Source for Ham Radio Fun and Information!



HAM UNIVERSE

MULTIBAND ONE ELEMENT VEE BEAM

BY LA0HV

PETER OF NORWAY

A Six Band One Element Beam!

20 meters thru 6...cool!

Hi N4UJW.

Thanks for a GREAT web site !!!!!!!

"I sent this email to Darrell, have a look, I think you will like it!"

Vy 73 LA0HV, Peter

YES PETER, WE DID LIKE IT!.....HERE IT IS FOR ALL HAMS TO BUILD...ENJOY!!

THE ANTENNA!

"First of all THANKS for the great web site of the "ONE ELEMENT V-BEAM FOR 15 METERS from **Darrell, KB4XJ!**

It really turned my antenna farm upside down! And what a relief.

My wife loves me again!

It reduced the antenna farm from several Quads and 3 element junior beams for several bands into the latest one element design.

A 6 band one element horizontal V-beam covering 20, 17, 15, 12, 10 and 6 meters!

Giving from 2.1 dBd (thats over a dipole) on 20 meters to 10.8 dbd on 6 meters."

Design is simple:

Take a Double Extended Zepp design for 6 meters using 1/2 inch or larger element material such as EMT, copper or aluminum. Copper is heavy! **DO NOT USE WIRE** (design freq. 51.110 MHz - "downunder DX window")

Each element will be 12.33 ft per side.. Feeder must be 400-600 Ohm ladderwire for at least 2.64 ft. (See Design calculator below)

Mount it in a **90 degree angle** just like the "**KB4XJ**" [Horizontal V-beam](#) shape.

(I have not experimented with any other angles)

Now connect a 4 ft 400 Ohm ladderwire.

Connect a 4:1 CURRENT balun at the end of the ladderline (balun design must cover 6 meters)

Connect a remote tuning unit directly to the balun (ATU must cover 6 meters) for example, the LDG RT11 ATU. A GREAT TUNER!

(Click here for info. [The LDG ELECTRONICS RT11 ATU](#)). **Click back here when done.**

The ATU is not a good solution for "normal" beams, because you cant tune all the other elements so easy.

But this is a ONE element beam so it WORKS GREAT!

Connecting a tuner directly at the feedpoint (the balun) will give a TRUE MATCH, not just a happy transmitter.

(Dont use a "by the rig" tuner, it won't do well).

Look at the dimensions and GAIN of this antenna:

On 20m: One element + wire is 1/4 wave. Gain: 2.1 dBd. Fb > 18 dB

On 17m: Almost a 1/2 wave dipole. Gain: 2.8

On 15m: 1/2 wave dipole. Gain: 3.3 dBd

On 12m: A little longer: 4.0 dBd

On 10m: The antenna is a little out of band but the Balun and RT11 tuner does the job. Gain: 5.8 dBd

On 6m: EDZ v-beam. Gain: 10.8 dBd. Fb > 25 dB

ALL WITH ONE ELEMENT !!!!!

Now isn't that cool!

Vy 73 LA0HV, Peter

Horizontal V-Beam Diagram

LA0HV EXPANDS ON A GREAT DESIGN!

THE BELOW INSTRUCTIONS WERE TAKEN FROM VARIOUS EMAILS FROM PETER, LA0HV with added comments by the original designer of the ONE ELEMENT VEE BEAM

Darrell, KB4XJ

Some contents edited for clarity.....excuse any spelling errors...English is not his native language!

Here is the basic theory:

The triDouble dipole has two elements of 3/4 wavelength each.
It has resonance at the design freq but the impedance is high (500 Ohm) and the reactance/inductance value changes dramatically when you change frequency.

To compensate for this you shorten the element length a bit and add openwire, 400-600 Ohm (not critical). This will decrease impedance to 200 Ohm at the design frequency.

This is why I use a 4:1 Current balun (must be a current balun).

This is the Extended Double Zepp, EDZ design parameters:

Length of each element: $0.64 \times l$

Minimum length of ladderwire: $0.137 \times l$

Now the great side effect is, that the antenna will work as good as, or better than a dipole at any frequency higher than the frequency that match a 1/4 wavelength at one of the elements.

Now using an open wire feeder, it will also work at the lowest freq and up, corresponding to a 1/4 wavelength, when you add the element length to the wire length. But now of course, gain will decrease because the ladder wire will be a part of the antenna.

Now the EDZ will be easily matched with a remote ATU that can handle rapidly changing reactance/inductance values. A remote ATU that can handle swr of 1:10 will do the work easily.

Back to the V-beam design:

The EDZ-V-beam with design freq at 51.110 MHZ will work with very high forward gain at the design freq, and as a normal "KB4XJ" V-beam at the 15 meter band (look at the element length).

Using open wire feed, minimum 4 ft
(longer is ok, but remember it is a part of the antenna at frequencies under 21 MHz), will give an easy match from 14 MHz and up.

Conclusion: The trick is to use openwire, a 4:1 balun and a Remote ATU like the LDG RT11 TUNER connected directly to the balun.

Vy 73, Peter
LA0HV

THE LATEST INFORMATION

EMAILs RECEIVED AS OF (11-12-02) from Peter LA0HV and Darrell KB4XJ

Hi Darrell & Don.

I just finished the last experiment of the year. It's snowing heavily now in Norway, 1 ft per hour!
Minus 10 deg Celcius Brrrr

Last experiment revealed something very interesting about the current in the elements of the V-Beam:

I made the KB4XJ 15m V-Beam design using thin wire, same length and angle.

This happend: Field strength measurement now showed a major backloop and a decrease of forward gain (almost no front to back). You can say that the Beam effect almost disappered.

I then took 1.25" kopper (copper) tubes, same length and angle, and all of a sudden I got a V-beam again. Backloop gone, forward gain increased to almost 6 dB !!!!!!!!!!!

So .. conclusions from a freezing cold, windy Norwegian Hill-top is:

**A "fat" element is turning the design from a resonant V-wire antenna into a Aperiodic (stable current) element V-Beam. The thick elements are doing the same job as a terminator in a Rhombic design .
WOOOW !!!!!**

Freezing smiles from LA0HV.

Vy 73 Peter

From: Darrell & Kay Koranda [mailto:kb4xj at strato.net]

Sent: **9. november 2002** 01:16

To: Peter Grün

Re: Developing a 6 band Single element horisontal V Beam

Hi Peter,

The Field Strength Meter and getting readings.

I checked across the back side of the V beam and showed a field strength reading of a .1. At the sides of the front ends power rose .5 and just inside the ends power rose to a 1. In the near center power rose 2. and in the dead center it was a 3. In just the field strength reading I was figuring around 28 db difference between front to back. In the tests I made I was using 10 watts of power. The antenna performed very good 2 years ago when I first truly tested it on field day 2001. Field day 2002 was not as good, problems with generator, blowing rain. Anyway back to the Horizontal V, in my early study on long wire antennas it was noted that power was related to one wire and that when a wire had a twin, the power doubled. Further study of log periodic dipoles (when a log dipole is bent forward it will have an added gain of 2.5 db., it was also found the beginning horizontal V was a 1/4 wave. Now in my

experience I found that induction between the elements changes the resonant frequency and lowers the frequency of a dipole and as a result you have to add 2 inches per side to make up for the induction factor. In your 90 degrees configuration, the higher you go in frequency the broader the front lobe should be, in that a horizontal V at 90 degrees at 1/4 wave on design, at longer wavelengths the V angle can be narrowed down, but the antenna does work and I wonder why it was never truly correctly reported, not having the works of **Dr John Klause** at hand. I spent 4 months researching the horizontal V antenna, and I spent over a month refining the center mount and have the antenna and mount down to a lean **7 pounds!** Darrell KB4XJ

=====

THESE LAST TWO EMAILS ARE UN-EDITED!

----- Original Message -----

From: Peter Grün

To: 'Darrell & Kay Koranda'

Sent: Friday, November 08, 2002 9:51 AM

Subject: SV: Developing a 6 band Single element horisontal V Beam

Hi Darrell.

The pointing right up idea of yours is also greate. I once did that experiment with a 2 element for 80 meter. For a long time I irritated me that the G5RV did'nt preform wel. I found out that when you are using a Inverted V type antenna over a sandy or rocky soil, it dosent work (I live on a rocky hill). The ground is absorbing the E-field. The reason why the Inverted v type antennas like the G5RV works for most people, I think, is because the Earth with a good ground-mirror soil works as a FireBack reflector.

So I took a 80meter dipole and mounted a reflector between the dipole and ground, the "beam" pointing directly in thy sky. The effect was thremendous! Within a 1000 miles range nobody understood how my signal could "hit" them with such a ekstreme powerfull strength. It was a 80 meter contest winner antenna. I think that it also is a good DX antenna, the only problem is that stations within 1000 miles is "bending" your S-meter, so you really need ekstremly strong filters to be able to work in the DX-window.

Back to your V-beam: I dont understand how it is possible to actually get a good FB-ratio on the V-beam. I did some fieldstrength readings and I am still suprised!!! It's so cool! Now talking about "cool" winther is closing in on me here in Norway so I have to wait until april for more eksperiments. Havent got any RTTY at the moment, but wil get some equipment during the winter, I wil look for you on 15 then.

Vy 73 de LA0HV, Peter

-----Opprinnelig melding-----

Fra: Darrell & Kay Koranda [mailto:kb4xj at strato.net]

Sendt: 7. november 2002 13:02

Til: Peter Grün

Emne: Re: Developing a 6 band Single element horizontal V Beam

Hi Peter, Did you do any Field Strength readings yet? That is what shocked me with the original design of the horizontal V design on 15 meters. The very high increase in forward field strength in the antenna and the decrease to the rear, could hear 360 degrees but could see a noticeable increase on the S-Meter when you rotated to the right direction. It really nice that the antenna can be rotated with a cheap TV rotator, I'll have to try your modified version. I was thinking of trying another experiment but haven't had the time to do it yet, I was thinking of pointing the V straight up and using the sky to bounce off of or launching at a 30 or 40 degree and up, of the two experiments I think the second may be of a better. In the First your pulling the signal straight down out of the sky and shooting them back up and scattering, in the second your pulling signals down in a direction and shooting back in the same direction. The First pointed up has the advantage of making your antenna appear to be say 75 miles up with nearly omni coverage. The Second pointed off with a 30 or 40 degree rise should provide longer distance. This is what I think will happen, the extended double zepp is basically a 3/4 wave antenna shorted to 5/8 wave with a 1/8 wave of ladder line, I have one but haven't tried it in the V configuration yet. I have time constraints and have to go off and work, I started my own business in refrigeration repair and also work with a solar pool heating contractor and I have to get going to work, we have a 40 panel system to put back on a building and we spent 6 hours yesterday just putting back up 4 pieces of pipe, and it looks like another 2 days on the job. If you operate rtty, I operate around 21.278 Mhz, current project is connecting my new radio a Patcom PC 9000 to my Pakrat 232 TNC and then to a old laptop for some portable rtty with the One Element Beam with Solar Power. Have yet to get the charge controller for the solar panel, I'am using a string of silicon diodes to drop the voltage to 13.8 volts DC. Got to Go good by for now, hope we can exchange information later. Darrell KB4XJ 73's

BACK TO ANTENNA LAB
ONE ELEMENT VEE BEAM
PROJECT

MHz

=

ft. (or

inches.)

**USE THIS CALCULATOR
FOR EXPERIMENTATION!**

>>>>

or use these formulas

one leg = $630/\text{freq mhz} = \text{ft}$

ladder line = $135/\text{freq mhz} = \text{ft}$

EMAIL

[DARRELL](#)

[KB4XJ](#)

EMAIL

[PETER](#)

[LA0HV](#)

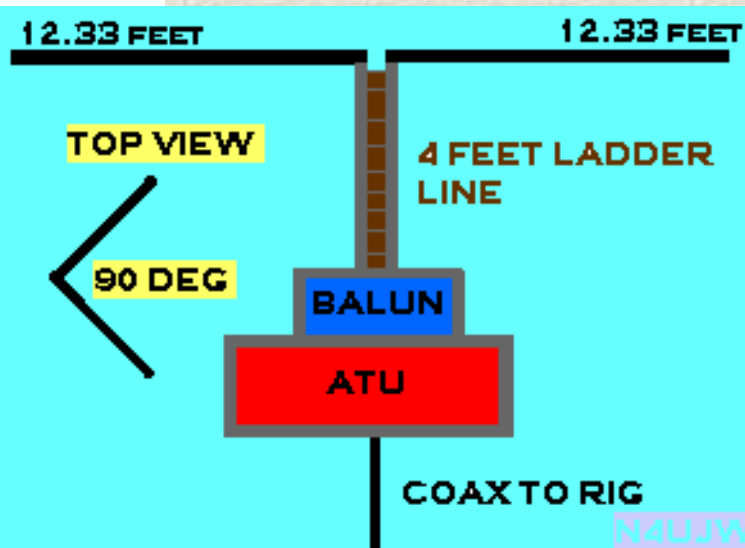

EDITORS NOTE from N4UJW:

"In the true spirit of Amateur Radio, Peter saw the original plans for the ONE ELEMENT BEAM on this site and saw that an improvement could be made to this fine design which you have just seen AND HAS SHARED IT WITH ALL OF US!

Can YOU improve on his improvements or have a good antenna design or antenna project that is hard to find on the internet? Please send them to us!" [email here](#)

EXPERIMENT! EXPERIMENT!..... 73 N4UJW

Peter Grun

LA0HV

Svinndalveien 96

Skiptvet, 1816

NORWAY

License Class: A

The Cobwebb HF Antenna

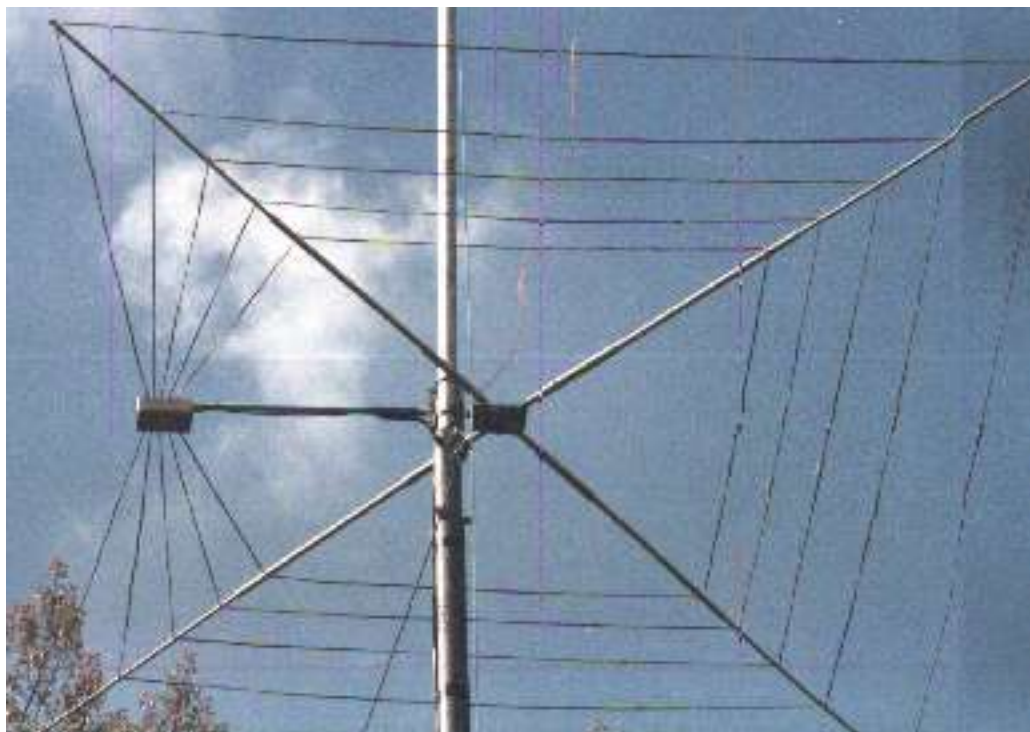

The G3TPW Cobwebb antenna covers five bands, 14 - 28 mhz, including the WARC bands. It is made by SRW Commuications Ltd (Steve Webb), Astrid House, Swinton, Malton, N. Yorkshire YO17 0SY (tel: 01653 697513).

It is strongly made using fibre glass rods and comes pretuned, but is easily adjusted to one's own frequency of preference if required.

It consists of five nested dipole balun fed and mounted horizontally. Rotation is not required. Fed with 50 ohm coax. Can be used indoors in a loft as it only measures eight feet across and is very light to handle.

I use one here at G3YCC mounted on a pole at the bottom of my garden, see photograph. Note, in my case the pole passes through the centre of the Cobwebb, but it works very well and I have had a QSO on SSB - rare for me! - with VK on 15m through contest QRM.

Although I have no commercial connection with Steve, a professional aerial designer, I have heard him speak on antennas at our local club and can recommend the Cobwebb, particularly for those with restricted space. I have a friend who uses one in his loft, which enables him to get onto 5 bands, which otherwise he could not do, owing to available space outside.

[Back to the first page](#)



[Double-L](#)

Double-L Antenna For 80/160

Don Toman, K2KQ

toman@ibm.net

A popular misconception about vertical antennas for the low bands is that they must have elaborate ground systems. Here's a vertical antenna for 80 and 160, fed with a single feed line that is simple, effective, and requires no ground system. You won't beat the 4-squares, but you will hold your own against a grounded quarter wave with ridiculous amounts of copper in the ground.

Rather than get into the theory of why this antenna works, I will simply describe it here and let results speak for themselves. If there's a demand, I'll do a follow-up article on the relevant theory.

The antenna is a center-fed half-wave vertical with about 70 feet of vertical length with the remainder of the top and bottom of the antenna bent horizontal and parallel to each other. The antenna looks like a squared-off letter "C" fed in the middle of the vertical part.

Thus, the 160-meter antenna is a 270-foot dipole fed in the center with the bottom antenna wire bent parallel to the ground about 10 feet off the ground and the top at 80 feet off the ground. The horizontal parts are 100 feet long and parallel to each other.

The 80-meter antenna is a 130-foot dipole, fed in the center with 70 feet vertical and 30 feet horizontal 10 feet off the ground and 80 feet off the ground.

Think of it as an inverted L fed against an L. The two Ls are balanced with respect to each other and because the currents in the horizontal sections are out of phase, the antenna has a minimum of horizontal radiation.

The 80 meter and 160 meter antennas are separate, fed from a common coaxial feed line.

In my case, the 80-meter and 160-meter horizontal sections are about 30 degrees apart. The 160 horizontal wires run east while the 80 wires run east-northeast.

On both bands, the bulk of the current flows symmetrically in the center of the antenna, with the current peak about 45 feet off the ground at the feed point. On 80, the current loop peak is about 0.16 wavelengths above ground and on 160, the current loop is about 0.08 wavelength above ground.

The accompanying figure illustrates the antenna.

Home

Articles

On Air Activities

YCCC Web Links

Resources

Meetings

Scuttlebutt

About YCCC

Site News

Members Only

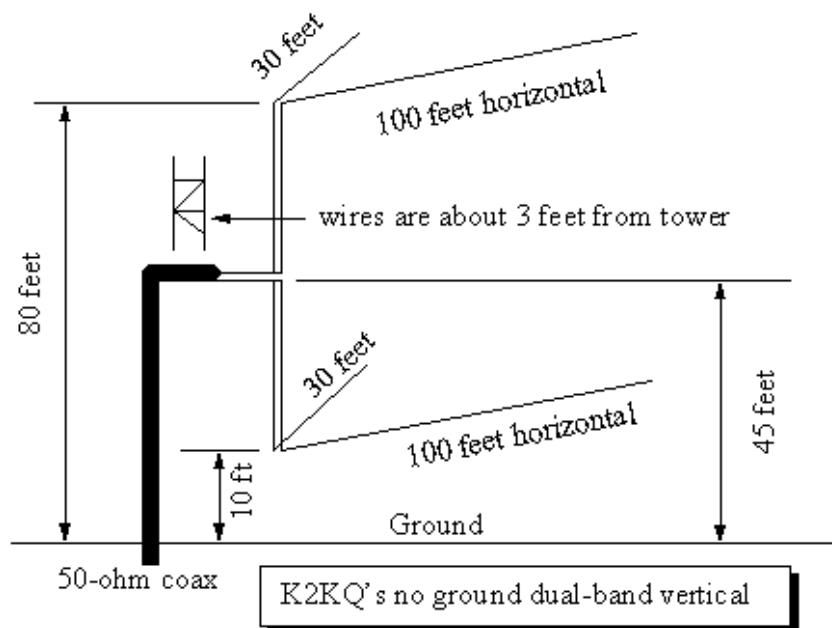

You can adjust the resonance of the antenna by adjusting the lengths of lower horizontal sections. The small asymmetry doesn't bother anything. The center impedance of mine at resonance is very close to 50 ohms on 160 and close to 70 ohms on 80. The 160 antenna presents high impedance at 80 meters and the 80-meter antenna looks like a parallel capacitor across the 50-ohm 160 antenna. The 160 antenna covers 1800-1860 with under 2:1 SWR. I needed to take about 2 feet off the horizontal section to get mine resonant at 1830. If 80-meter current flows in the 160 antenna, it tends to flatten the current loop in the vertical section.

The 80 meter antenna is resonant at 3750 with the 130-foot length shown. The VSWR is under 2:1 over the DX part of the 'phone band. It needs to have some length added to cover the CW portion. I haven't tried to bring it to resonance in the CW band, but have chosen to feed it through a tuner.

I originally had this antenna hung from trees. This year I put up an 80-foot Rohn-25G with three sets of guys. I hung the wires from ropes attached to the tower so they are separated from it by about 3 feet. The coaxial feed line comes off perpendicular to the antenna and is then taped to the tower. The center conductor goes to the top and the shield goes to the lower part. Before the coax turns on to the tower, I've wrapped some 30 feet of it into a coil. I expected to see a lot of interaction, but the tower and guys seem well off resonance at the operating frequencies and I didn't see any to worry about.

The first QSO on 80 was VK6LK, long path on SSB at sunset on September 12. I've worked a few ZSs, HF0POL, LU, and the usual Europeans. On 160, the first QSO was KP4SN on September 15. In the couple of weeks since hanging it from the tower, I've worked ZS6UT, TU2MA, TL5A, VK6VZ, VK6LK, VK3ZL and NL7Z and the usual horde of Europeans on 160 with no fuss. I run about 800 watts out from a Ten-Tec Centurion.

Last January, I had about 200,000 points with 750 QSOs in the CQ WW CW 160 contest using the predecessor hung from trees.

[[Home](#)] [[Articles](#)] [[On Air Activities](#)] [[YCCC Web Links](#)] [[Resources](#)] [[Meetings](#)] [[Scuttlebutt](#)]
[[About YCCC](#)] [[Site News](#)] [[Members Only](#)]

Comments or suggestions to webmaster@yccc.org
Copyright © 1997-2002 Yankee Clipper Contest Club

THE LATTIN 5 BAND ANTENNA

(DESIGNED BY W4JRW)

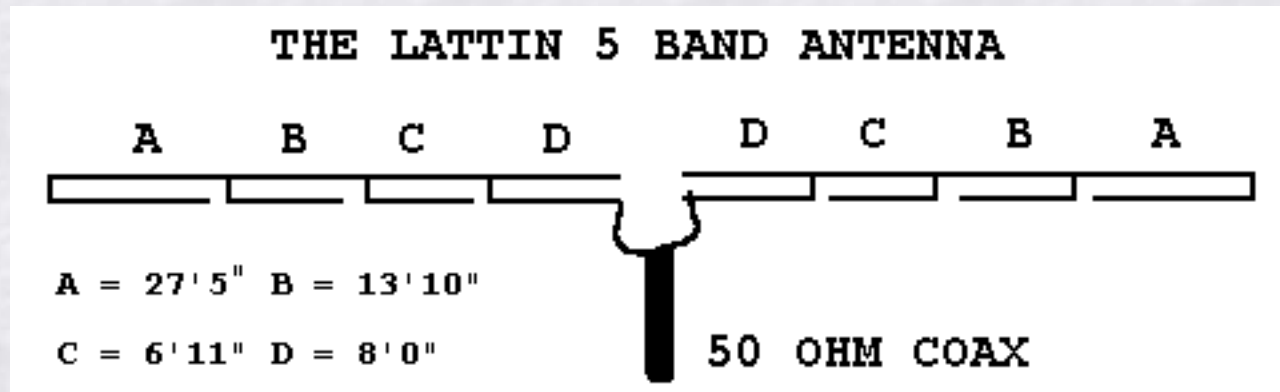

THE LATTIN 5 BAND ANTENNA (FOR 80, 40, 20, 15 AND 10 METRES)

The antenna was named for **W4JRW** who invented it and holds a patent on the basic principle and uses quarter wave stubs, which act as insulators at the frequency for which they are cut. For example, the 6'11" stub (quarter wave times the velocity factor 0.8 of the feed line used) blocks RF for 28 mhz from reaching the rest of the antenna.

In the example shown in the diagram, tubular foam filled 300 ohm feed line was used, which has a VF of 0.8. Other feedlines may be used, for example, slotted ribbon and the length of the stubs worked out using the correct velocity factor

BUILDING THE LATTIN ANTENNA

This will require some forethought and planning. Avoid cutting the continuous top wire, which supports the whole system. I wonder if it might be an idea to use a suitable polypropylene line to support the wire, which may be subject to breaks, especially at the solder points?

A suitable centre piece may be constructed and constructors may want to include a balun at the centre of this balanced antenna, which is fed with unbalanced line (coax).

If you do have a go at this, please let me know - I have always wanted to make one and never as yet got round to it!

A version of the Lattin could be designed for all bands, including the WARC bands - get snipping!

Frank, G3YCC.

[Back to the first page](#)



The CarChip™ ODB II Scan Tool
is @ www.provantage.com



Find on this site...

[Site Index](#)

- [Exams](#) Search site: Call sign search:
•[Clubs](#)
•[Hamfests](#)
•[Addresses](#)

ARRL Member Login...

Username: Password:

[Register](#)

Quick Links...

- [Join or Renew](#)
•[Catalog & Store](#)
•[ARRL Courses](#)
•[Classifieds](#)
•[Getting Started](#)

[Operating Activities](#) [Licensing](#) [News/Bulletins](#) [Services](#) [Educational](#) [Public Service](#) [Support](#) [Donate to ARRL](#) [ARRL Info](#) [Text-only/Printable](#)

Trapped Antennas

[ARRL Technical Information Service page](#) · [TIS Menu page](#)

Additional information on this subject and related topics can be found in back issues of [QST](#) and the following:

[The ARRL Antenna Book](#)

The [ARRL](#) has an extensive [catalog](#) of books and materials related to [Amateur Radio](#).

Articles

Note: Some of the following articles are in Adobe Portable Document Format (PDF) files. To view and print these files, you'll need a copy of Adobe's Acrobat Reader program. (Version 3.0 or later required). More information [here](#).

- [Coaxial cable Antenna Traps](#) (1,318,022 bytes, PDF file) **MEMBERS ONLY**
QST May 1981, pp. 15-17
Both the coil and capacitor of a parallel-resonant antenna trap can be made from the same length of coaxial cable. Sound intriguing? Here's how.
- [Build a Space-Efficient dipole Antenna for 40, 80, and 160 Meters](#)
(570,975 bytes, PDF file)
QST July 1992, pp. 35-36
A new trap design, using only RG-58 and PVC pipe, yields better space efficiency than conventional coaxial traps.
- [Two New Multiband Trap Dipoles](#) (785,934 bytes, PDF file) **MEMBERS ONLY**
QST August 1994, pp. 26-29
W8NX details a new coax trap design used in two multiband antennas; one covering 80, 40, 20, 15, and 10 meters, and the other covering 80, 40, 17, and 12 meters.

ARRL Products:
Digital Communications
([More](#))

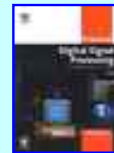

[Practical Digital Signal Processing](#) -

- **Now Shipping!** --

Gain a working knowledge of DSP applications, including communications and process control.



[Digital Signal Processing Technology](#) --

Essentials of the Communications Revolution. An understandable presentation and reference on DSP in contemporary communications technology.



[ARRL's HF Digital Handbook](#) -- 2nd

edition. Your computer and your radio--the perfect pair for global communication!



[VoIP: Internet Linking for Radio Amateurs](#) -- **Now Shipping!** --

Where RF meets the Internet! A

- [An Improved Multiband Trap Dipole Antenna](#) (156,121 bytes, PDF file)

MEMBERS ONLY

QST July 1996, pp. 32-34

You need this - traps with lower loss, higher Q, increased power-handling capability and four-band coverage. Also build a multiband dipole for 80-, 40-, 17-, and 10-meters only 84 feet long.

- [Taming the Trap Dipole](#) (151,344 bytes, PDF file) **MEMBERS ONLY**

QST March 2002, pp. 28-30

A trapped dipole for 10/15/17 meters

guide to four VoIP systems: EchoLink, IRLP, eQSO and WIRES-II.



APRS -- Moving Hams on Radio and the Internet -- Now Shipping! -- A Guide to the Automatic Position Reporting System

Note:

Contact information for suppliers mentioned in the above articles should first be confirmed using [TIS Address Database Search](#).

Bibliography (Members Only)

[ARRL Periodicals Index Search](#) - This database contains the *QST* index from 1915 to the present and the *QEX* index from 1981 to the present. For *QST* issues from 1970 to the present, and some selected articles back to 1922 (when construction articles featuring tubes began in earnest), identifying keywords have been added to the technical articles. By entering keywords (ANTENNA) or combinations of keywords (CONSTRUCTION ANTENNA VERTICAL HF) into the **Title words:** field, you may create dynamic bibliographies.

Technical article [KEYWORD list](#). [Hints for more successful searching](#)

Suggested keywords for more articles like the ones on this page are: [CONSTRUCTION TRAP ANTENNA](#)

Article Reprints:

Note: Reprints are available from the Technical Department Secretary, ARRL, 225 Main Street, Newington, CT 06111. Article copies must be prepaid \$3 for ARRL Members, \$5 for non-members. You may order by telephone (860-594-0200) and pay by credit card. Reprints can only be sent by mail and cannot be sent by or attached to e-mail.

This information was prepared as a membership service by the American Radio Relay League, Inc., Technical Information Service, 225 Main St., Newington, CT 06111 (860) 594-0214. Email: tis@arrl.org (Internet). ARRL HQ is glad to provide this information on the Web free of charge as a service to League members and affiliated clubs.

If you have any questions concerning the reproduction or distribution of this material, please contact:

TIS Coordinator
American Radio Relay League
225 Main St., Newington, CT 06111
Tel: 860-594-0214 Fax: 860-594-0259
(email: tis@arrl.org)

Page last modified: 11:03 AM, 18 Jul 2002 ET

Page author: tis@arrl.org

Copyright © 2002, American Radio Relay League, Inc. All Rights Reserved.

+++ DF4SA amateur radio website

+++

[home](#)

[about me](#)

[dxpedition and
contest stories](#)

[spider beam](#)

[contact](#)

Spiderbeam has now earned its own site.

It has been moved to: www.spiderbeam.net



[Home](#) -> [Antennas](#) -> Wire-YagiWire-Yagi [More-Yagis](#) [LPDA](#) [Six-Meters](#)

A TRI-BAND 2 ELEMENT PORTABLE YAGI

After operating QRP during the 1996 ARRL Sweepstakes Contest I decided that the next time I entered a QRP contest it was going to be with an antenna that had gain over the dipole antennas I was using! Operating from a temporary location, a tower and tri-band yagi constructed of aluminum tubing was not an option. After much thought and a lot of reading, I decided to build a tri-band 2 element yagi using wire elements. The results of this experiment are contained in an article published in the November 2001 issue of QST. A PDF file of the article as well as the EZNEC antenna files is available at the following links.

[Portable 3-Band Yagi Article](#)

[EZNEC zip file at QST](#)

ADDITIONAL NOTES:

Assembly

When you are ready to assemble the array, attach the 20 meter reflector and the driven elements first and then hang the array between two supports, (trees etc.) at about 5 feet above the ground. Pull it tight so that the array is fairly flat. It won't stay flat because the driven elements are heavier than the 20 meter reflector so support one end of the 2 x 2 end supports on a rung of a step ladder or box so that the array lies horizontal. Add the 10 and 15 meter reflectors next using a little less tension than the 20 reflector. Next attach the feed line. The last step is to adjust the V slings as mentioned below so that the antenna is balanced in the horizontal plane. All adjustment for lowest SWR, if needed, must be done with the antenna raised to its typical operating position. Do not attempt to adjust any of the element lengths or the hair-pin match for lower SWR while the array is close to the ground. Check the SWR on each band with the antenna at a height of at least 25 feet before attempting any adjustments.

V Slings

There are two V slings, one on each end. The secret is that they are not equilateral in shape. The combined weight of the driven elements and feed line is heavier than the reflectors. If the length of the sides of the V sling are equal, the array will turn with the 2 x 2 end supports positioned vertically. Increasing the tension on the side of the V that is attached to the end where the driven elements are attached causes the whole array to turn toward the horizontal plane. Do this by shortening the length of the side of the V that is attached to the driven elements. It is quite easy to adjust in the field. Once the V sling is adjusted, the array stays balanced. You can change direction 180 degrees by pulling on the the feed-line. If you pull it hard enough, the whole array will begin to turn-flip over. Stop it from turning too far by holding on to the feed line once the array has swung over to face the opposite direction.

Balun

It is not clear what to do with the coil of coax at the feed point in Fig. 1. This is meant to be a choke balun to choke off any RF from flowing along the outside of the coax shield. It is best to let the coax feed line drop straight down from the centre insulator, attach it to the centre of the hair-pin shorting bar with a plastic tie or string and then make the balun by coiling up the coax 6 to 8 turns with a diameter of 4 inches or so just below this point. The centre of the shorting bar is neutral potential so there is no problem mechanically attaching the feed line to it for support.

[Home](#)[Antennas](#) [HomeBrew](#) [Operating](#) [Design](#) [Links](#)**LATEST UPDATES:**

November 15/03, RELAY PROBLEMS; see Homebrew Page.

March 15/04, 100 Watt HF Power Amplifier Completed, info to follow.

April 5/04, New addition to link page.

July/August 04 QEX, see article on how to fix your HP8640 if it has no power output.

August 23/04, TOWER COLLAPSED, being fixed; see Antenna Page.

Welcome to VE7CA's Homepage

- **Operator:** Markus Hansen.
- **Location:** North Vancouver, B.C. Canada - Grid CN89.
- **Activities:** Contests, LF-HF-VHF-UHF, Homebrew, Antennas, CW, QRP

Biography:

I obtained my ham radio licence in 1959 at the age of 16 and was assigned the call VE7BGE. ([My first Ham Station](#)) After high school I obtained my 2nd Class Commercial Radio Licence at Room 19 in the City of Vancouver, BC. Upon graduating from Room 19, I obtained work as a commercial radio operator and weather observer at Alert BC off the west coast of Vancouver Island at a Loran Station. I was later transferred to Smithers BC, then served for one year at Alert NWT. After returning from the arctic, I was transferred to Terrace BC and finally to a Canadian weather ship named, The Stonetown, stationed off the West Coast of British Columbia. In 1967 I decided to return to school and enrolled in general sciences at the the University of British Columbia, (UBC). While at UBC I was a active member of the university ham club called HAMSOC. ([Hamsoc FD 1967](#)), ([1986 HAMSOC Reunion](#)), ([1992 HAMSOC Reunion](#)), ([1995 HAMSOC Reunion](#)). During my second year at university I met my future wife, Gaye. We were married in 1969. We have one daughter and two sons. Our daughter and youngest son are married and we are blessed with two grandchildren. In 1979 I was issued a two letter call, VE7CA.

I have been working in the commercial real estate industry for the last 30 years and have no plans to retire. Here I am in front of my operating desk looking for you on my homebrew HBR2000!



I continue to be active operating mostly CW, chasing DX, looking for new grids on 6 meters and entering contests under the QRP category. I have a strong interest in antennas and have published 4 articles on antenna designs that I have developed. Homebrewing is something I really enjoy as well and lately I have been absorbed in building a high performance HF transceiver. See the above menu for further details regarding my antenna articles and homebrew projects.

Antennas:

- 160/80 trap dipole, switchable to Vertical T antenna.
- Triband Dipole at 35 feet.
- Portable 2 Element Wire Tri-band Yagi, See QST November 2001
- Portable 2 Element 6 meter Quad
- Portable 3 Element 6 meter Yagi
- Cross Polarized 144 and 430 Mhz Hi-Gain yagis.

Ham Gear and Test Equipment:

- Homebrew 160-10 Meter High Performance Transceiver HBR2000
- Homebrew 6 meter CW/DSB 10 Watt DC Transceiver
- Modified Norcal Sierra QRP CW Transceiver 40-10 meters
- Homebrew 40 Meter Optimized QRP CW Transceiver based on W7EL design in August 1980 QST
- Homebrew 160-10 Antenna Tuner

Kenwood TS-940s HF Tranceiver (FOR SALE)

Yaesu FT-726R VHF/VHF Transceiver

Homebrew 6 Meter 70 Watt Solid State Amplifier

Heathkit SB220 Linear

Homebrew Spectrum Analyzer based on W7ZOI/K7TAU design, August 1998 QST

Homebrew Personal Network Analyzer based on design by Steve Hageman, see Jan/Feb 1998 QST

Homebrew Power Meter by W7ZOI/W7PUA, June 2001 QST and K3NHI additional features May/June 2002

QEX

HP8640B signal generator. See July/Aug 2004 QEX if your gen. has no output power.

You are visitor **04263** since Aug 26, 2002

Copyright (c) 2002,2003 by Markus Hansen VE7CA. You may contact me at my call sign @rac.ca



"Home of the RASCAL"

My Favorite Multi-Band Antenna

The "WINDOM"

By G. E. "Buck" Rogers Sr; K4ABT

In September of 1949, I was tired of climbing poles and trees to move, remove, add, or change my single-band HF antenna's. In those younger years of my HAM radio hobby, I had used single band dipoles and doublets for almost every HF Amateur band. I had tried long-wires, doublets, dipoles, and Zepps, but again, operation was restricted to single band operation, maybe two bands at most.

I had heard of the "Windom" and read a few articles about the Windom, but most of my thoughts were ... ho-hum.. just another dipole fed a bit off-center. Then one evening at a meeting of the GARC in the old "Sea Scouts" club house near the Coosa River in Gadsden, Alabama; I heard some of my "elmers" Gilbert Watson (SK) W4PAC, Gale Caudle (then W4CFB), Jack Kennamer (SK) W4YPC, Bob Bynum W4USM, Austin (Vic) Vickery, Walter Damkohler (SK) W4EBO, W4CWF, Ed Elkins (SK) W4CDI, Homer Dupree (SK) W4OZK, Jim Runyan, Homer O'Dell, Robert Martin, and others discussing the Windom *all-band HF antenna*. It was when Jack (W4YPC), mentioned ***using one (Windom) antenna, on the all HF bands that my ears went directional!***

That last phrase caught my undivided attention. "most all HF bands,etc"
What! *A multi-band HF antenna* ? Surely I had been blessed.

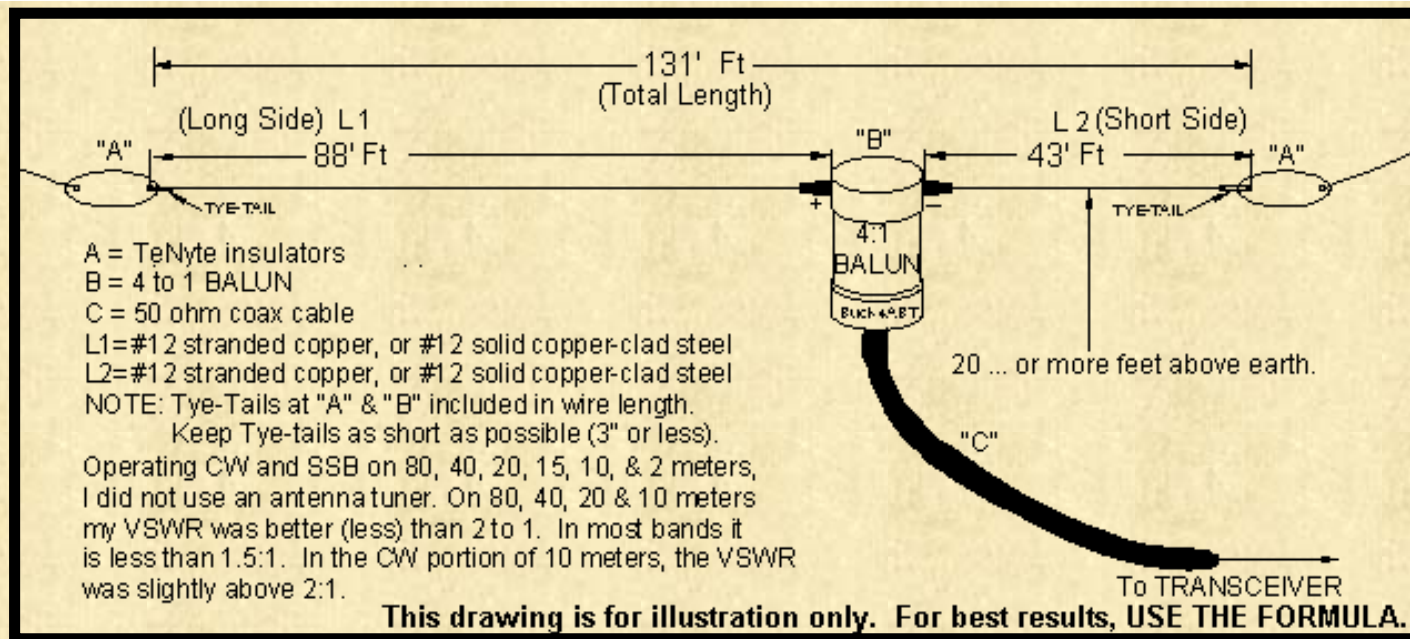

To think that I could put up a Windom, and no longer have to climb the poles and trees to hang another (single band) HF antenna was great news to me. To be able to use it without an antenna tuner was icing-on-the-cake. For a kid without extra funds, an antenna tuner was a luxury that I could *not* afford. Even my transmitter was a single 807 rig I homebrewed on an old *Atwater-Kent* radio chassis, my grand-father had given me.

In those days, a BALUN was unheard of. My Elmer's described, a means of connecting the coax to the off-center fed antenna using a nine (9) turn coil of the coax feed-line at the feed point. This coil of feedline coax formed a "de-coupling" loop. The de-coupling loop provided a crude means of matching the feed coax to the antenna, and at the same time, it would reduce the "re-radiation" (RF currents) along the outside (shield) of the feeder coax.

Today we have toroid cores and BALUN devices that provide a more efficient means of coupling RF energy to the antenna (reducing the VSWR, "standing-waves"), while performing better impedance matching. In the drawing shown above, I've drawn the exact dimensions of the Windom I built in 1949. The only differences in my Windom of 1949 and today are:

- 1) the material the insulators are made of, and
- 2) I've substituted a 4 to 1 BALUN for the 9 turn, 8 inch diameter, decoupling loop.

AN UPDATE:

Since writing this article a few decades ago for a major HAM radio magazine, I've received tons of mail (and eMail) asking for more information, especially with regards to a 160 meter version; Here then is "the rest of the story."

First of all, we'll address the formula, and how to determine the length(s) of each section, using the same old formula that I used in 1949.

Long side.... = 468, divided by the frequency, then multiply by .64 (= Feet)

Short side.... = 468, divided by the frequency, then multiply by .36 (= Feet)

THUS; for 160 thru 10 Mtrs.....

Long Section; 468/1.8 MHz = 260 x .64 = 166.4 feet.

Short Section; 468/1.8 MHz = 260 x .36 = 93.6 feet.

For 75 thru 10 meters do similar math to arrive at/near the dimensions shown in the drawing below, but for best results, use the formula.

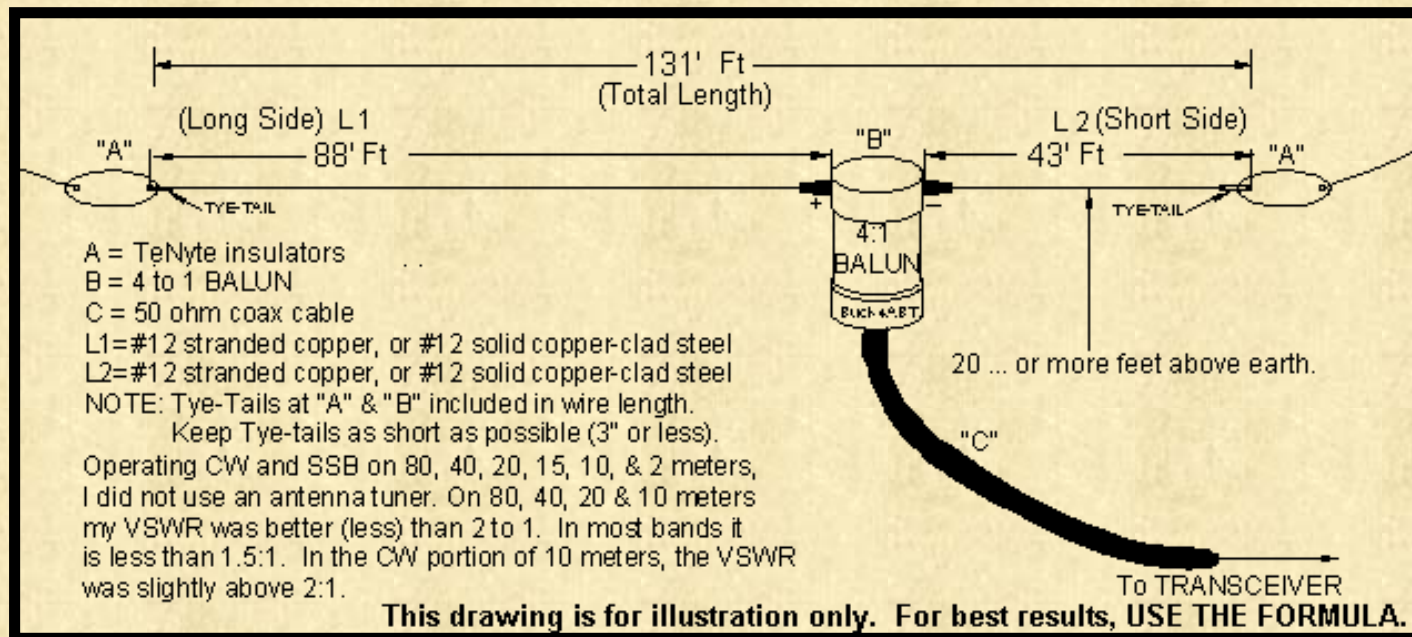

The Windom can be installed as an inverted VEE, or as a sloper, **but in no case**, should the angle be less than 90 degrees against itself. *To use an angle that folds against the pattern of the opposite end of the Windom, would change the impedance of the feed-point, change the multi-band features, and most important, destroy the radiation characteristics of the antenna.*

In other words, install the Windom as you would any other dipole, while using a common sense approach. The fact that we are feeding

this Windom using coax, and a single balun, gives us the ability to construct it as an inverted VEE or at a "real estate saving (angle)" without destroying the features and performance of the Windom.

This is *not* true with those antennas fed with ladder-lines and those that have several impedance transitions built into the feeders

of the "basic" Windom..... There's more to come, so read on!

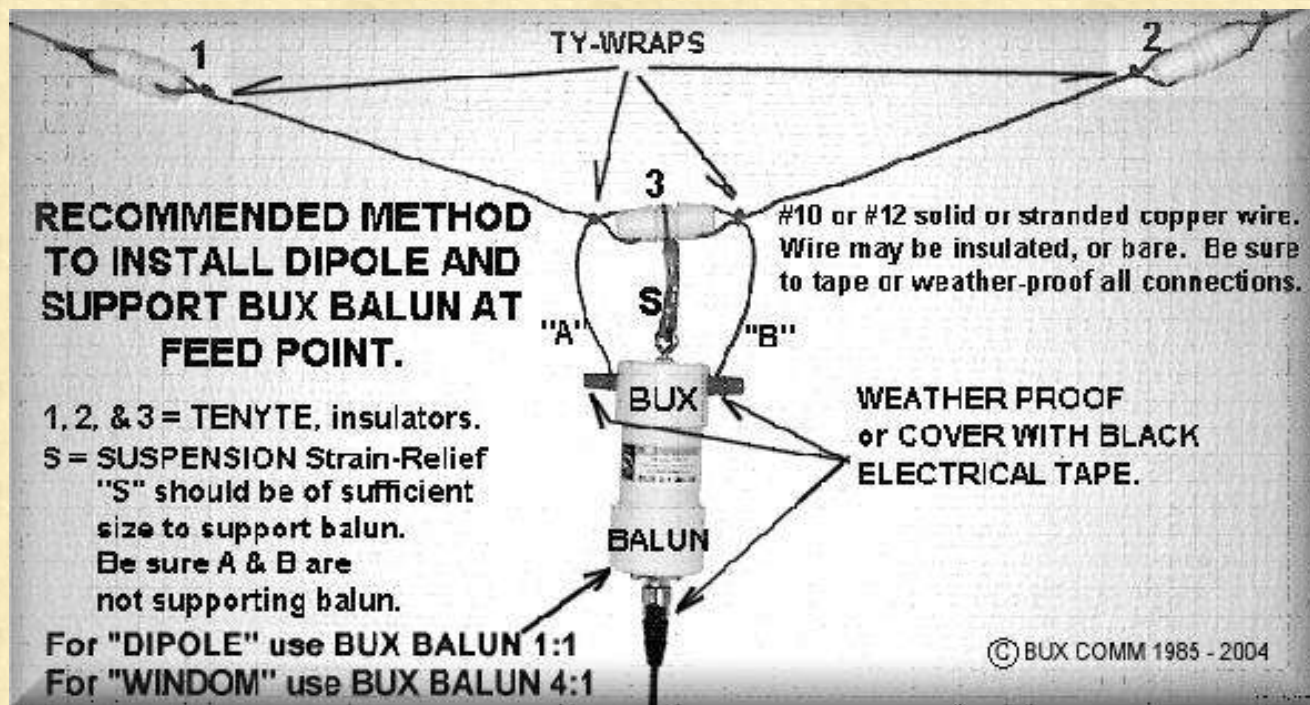

ANTENNA INSULATORS

Weatherproof, (TENYTE) insulators. Perfect for your DIPOLE or Windom antenna.



For the apartment dweller, you can now hang the 20 meter doublet in the attic. I've QSO'd with stations all over the world with the 33 ft dipole in my garage attic. One insulator at the center, and one each end.

It's great for other HF [WINDOM](#) and single-band dipole antennas. Dielectric strength is comparable to the old ceramic insulators, without susceptibility to cracking or breakage under impact or extreme temperature changes.

Package of 3, \$2.99 ANTINSL3

[Order Now](#)

Package of 10, TeNyte Insulators \$8.99, ANTINSLX10

[Order Now](#)

Now it's time for me to P O the wire and cable vendors, and the proponents of Windom's with too many feed-line transitions. Twin Lead, Ladder-line, Window Line..... etc.. is an over-kill.. The trade-off is not...; I repeat; NOT... worth the pain and upkeep to replace it every year or two.

And trust me... It is NOT a problem of the ladder-line insulation quality or properties that I'm speaking of. I speak from experience; Wind will destroy ladder/twin-lead line. Even the robust type will succumb to the wind element in time.

IF; you decide to use ladder line, make one turn (twist) to each 20 to 24 inches of line to decrease the wind resistance presented by the "flat" line..... even if it is "window-slotted" type ladder-line. By adding the one twist per 20 inches, it may last longer than three years.

COAX does NOT present a high degree of wind resistance, and it'll last much longer.

Having *been there, done that*, and heard similar horror stories from others; another question arises regarding parallel line currents that come with the use of so-called balanced (twin-lead) feed-lines. To add injury to the ladder-line proposition, the balanced line may also assume the properties of a *single wire feeder (yuk)*.

Some purveyors of the Windom that use ladder-line transitions, must use two impedance matchers (or BALUNS) with their (knock-off) Windom. One is to transition the coax outside the HAM shack (*heaven forbid, we use ladder-line inside the shack... RF "feedback" in everything*), to the ladder line, then another at the Windom (antenna) feed-point to choke off parallel current from the ladder-line.

Since the feed point of this antenna has been found to be near 220 to 260 ohms, *the use of a 4:1 BALUN to join our coax to the antenna*, emerges as a compromising solution.

Let's not lose sight of the most important advantage of using this antenna; and that is: It provides us with a powerful, multi-band antenna, and a minimum of feedline components.

Now for the "perfectionists" among us, if you want to smooth out the hills and valleys on some of the bands, add your antenna tuner to the system, and the Windom becomes very flat across the bands. When I say "flat," we are talking about reducing the VSWR to a minimum, to produce a good forward power, transfer of RF energy to the Windom.

We're having fun already... with the Real WINDOM antenna



The "Windom Antenna" was described by Loren G. Windom in QST magazine, September 1929. Pages 19 through 22. It is named after its inventor/designer.

Loren Windom, W8GZ, was first to reveal the antenna to the radio amateur community by describing the antenna in the September 1929 issue of QST. It was by Windom's name that the antenna became known. The Windom antenna is an off-center fed dipole with an unbalanced coax feedline.

In 1937, the Windom was first described as a compromise multiband antenna. The antenna can be employed on 80, 40, 20 and 10m with considerable, though acceptable levels of VSWR. What became perhaps the most popular multiband Windom design of all, was the German-made Fritzel FD4 antenna, described by the late Dr. Fritz Spillner1, DJ2KY, in 1971. It had the same dimensions as the multiband Windom antenna, but fitted with a 200Ω (4:1) balun in its feedpoint and fed with coax.

Today, many radio amateurs are using multiband Windom antennas with more than satisfactory results. It would not be without reason that Windom antennas are being employed during IARU HF World Championships! and most of all, by "high-stake-contests." **Perhaps many young hams ignore the multiband Windom antenna because of its sheer simplicity and may be thinking it is too good to be true.** The complexity of feeding other dipoles and doublets, the losses in dipoles with traps and the esoteric marketing of some other antennas seem to appeal to them more.

[CLICK HERE: and read more about the evolution of the WINDOM, to ZEPP, to VHF J-POLE.](#)

BUX BALUNs should be installed at the antenna feed point, or where the coax or feed-line attaches to the above ground antenna.

BUX BALUNs are used to connect balanced antennas to unbalanced transmission lines, such as coax cable. Their primary purpose is to prevent antenna (RF) currents from flowing down the outside of the cable. Another function of the BUX BALUN41 is to match the impedance of an unbalanced coax to the balanced feed point of a balanced input antenna(s). BUX BALUNs may also be used as "line isolators" anywhere along the cable to prevent the destructive influence of induced RF currents (VSWR).

BUX 1:1 BALUNs are current BALUNs. They consist of several large, [number 73, ferrite type 44 cores](#). **BUX BALUN11** operate from 3.5 to 72 MHz and allow use of RF power to the rated capacity of the BALUN.

BUX 4:1 BALUNs are voltage BALUNs. They consist of a large, [number 41, ferrite dough-nut bobbin](#). **BUX BALUN41** operate from 3.5 to 55 MHz and allow use of RF power to the rated capacity of the BALUN.



During this month, when you purchase either of our BUX BALUNs, we will include 3 (Tenyte™), insulators FREE. A \$2.99 value. Be sure too mention this offer in

the "Comments" space on the order form check-out page!

At BUX COMM, *We don't cut corners!

The components used in the manufacture of our BALUNs are from top quality components, beginning with the Silver Plate SO239 connectors and center insulator is made of teflon™(E.I Dupont). The wire we use to wind the ferrite donut is heavy-duty, silver flashed wire, with teflon™ insulation that will handle RF voltages above 5000 volts, and temperatures above 2000 degrees. The binding posts are heavy-duty, tempered brass, with end holes and side-thru holes to accommodate either type loop-thru connection. A double-shoulder brass capture nut is used to add a secure bite and improve antenna wire electrical connections. With our BUX UN UN (ONION), the coax is Belden™ and the PL259 connectors are Amphenol™.



4:1 Balun, BUXBALUN 41 \$19.95

[Order Now](#)

- o 50 ohm, SO-239 unbalanced input
- o Balanced output
- o 1.6 to 50 MHz
- o Toroid (Voltage) design
- o Heavy Duty, Lightweight construction
- o Sealed against moisture

1:1 Balun, BUXBALUN 11 \$19.95

[Order Now](#)

- o 50 ohm, SO-239 unbalanced input
- o Balanced output
- o 1.6 to 50 MHz
- o Toroid (Current) design
- o Heavy Duty, Lightweight construction
- o Sealed against moisture

BUX UN UN De-Coupling transformer, similar to above, but has SO-239 (female) input connector and output connector is 1 ft Mini 8 cable with PL-259 (male).

BUX ONION \$19.95

[Order Now](#)

4:1, 1.5kw Balun, BUX BALUN 41HD \$27.95

[Add To Cart](#)

Toroid design, wound with teflon covered, silver plated wire.* Heavy-Duty, construction.

1:1, 1.5kw Balun, BUX BALUN 11HD \$27.95

[Add To Cart](#)

Toroid design, wound with teflon covered, silver plated wire.* Heavy-Duty, construction.



BUX ONION Decoupling Transformer

BUX UN UN De-Coupling transformer, has SO-239 (female) input connector and output connector is 1 ft Mini 8 cable with PL-259 (male).

BUX ONION is an UNbalanced to UNbalance (UN-UN) *decoupling transformer* designed to be used specifically with [the DBLSPCL antenna](#).

High RF currents traveling along the coax feed-line shield can cause high VSWR. This decoupling transformer prevents RF currents from traveling down the outer shield of the coax.

The input connector is an SO239 (female) and the output connector is a PL259 (male), which mates the connector of the "DBLSPCL" RV/Apartment dweller antenna shown above.

BUX ONION \$19.95

Order Now 

WHY USE A **4:1 BALUN**

Krusty Olde Kurt is now going to repeat himself. Why? Because the same question keeps coming up over and over. And he wants everyone to get it right.

"I'm feeding my dipole with 600-ohm line. At the station end I need a balun to convert to 50-ohm coax. I need a 12:1 balun, right?"
Wrong! A 4:1 balun would be better.

Why is that? If your dipole is up, let's say, 35 feet then on 80 meters it will probably have a resistance at resonance of about 40 ohms. The actual resistance depends on the height above ground in wavelengths.

If the dipole is 40 Ohms then what do you see at the transmitter end of your 600 ohm line? If the line is a half-wave long (120 ft on 80 Meters) you'll see 40 ohms. Remember, a half-wave line repeats what it sees at the other end. But if it is a quarter-wave long you'll see 8500 Ohms! At other line lengths you'll see impedances somewhere between these two extremes.

So you are not going to see 600 ohms at the end of your 600-ohm line. That only happens if you have a 600-ohm antenna hooked onto it. With such a variation in impedance at the transmitter end of the line there is no one balun transformer that will match it. Most of the time the impedance will be above the 50 Ohms of your coax so a high impedance balun would be desirable. Unfortunately high impedance baluns don't work well when not matched.

Experience has shown that **4:1 baluns work best** in this service. They are more rugged and will take bad mismatches especially if they are wound on an iron powder core. So stop searching for that 12:1 balun. **Use a 4:1 BALUN and your system will work just fine.**

You can read Kurt N. Sterba "AERIALS" column in **World Radio Magazine**.



BUX MOBALUN

When you hear those strong HF mobile signals, here's one reason they stand out from the rest. By installing the BUX MoBalun near the input to your antenna, you deliver more RF energy to the antenna. At the same time, the BUX MoBalun prevents RF from traveling back along the shield (high SWR) of your coax. High power rating, Low-permeability toroid, with Internal composition fiber-glass to prevent vibration during mobile operation. For input and output connectors, we use only the best Silver plated, Teflon insulated, SO239 connectors. 700 watts PEP. Our **MoBALUN** is also ideal for marine antenna installations.

\$19.95 MOBALUN

[Order Now](#) 

ANTENNA INSULATORS

Weatherproof, (TENYTE) insulators. Perfect for your DIPOLE or Windom antenna.



For the apartment dweller, you can now hang the 20 meter doublet in the attic. I've QSO'd with stations all over the world with the 33 ft dipole in my garage attic. One insulator at the center, and one each end.

It's great for other HF **WINDOM** and single-band dipole antennas. Dielectric strength is comparable to the old ceramic insulators, without susceptibility to cracking or breakage under impact or extreme temperature changes.

Package of 3, \$2.99 ANTINSL3

[Order Now](#) 

Package of 10, Insulators \$8.99, ANTINSLX10

[Order Now](#) 

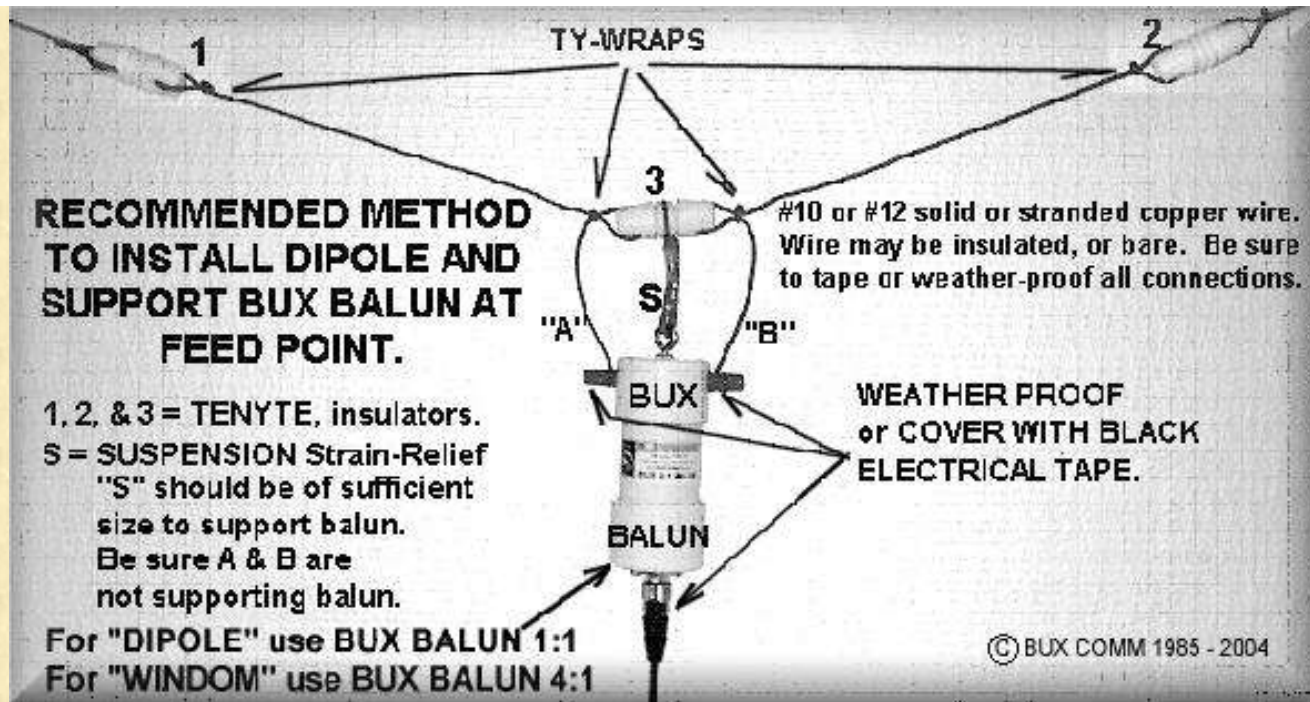

UHF DOUBLE FEMALE BULKHEAD (feed-thru) CONNECTORS

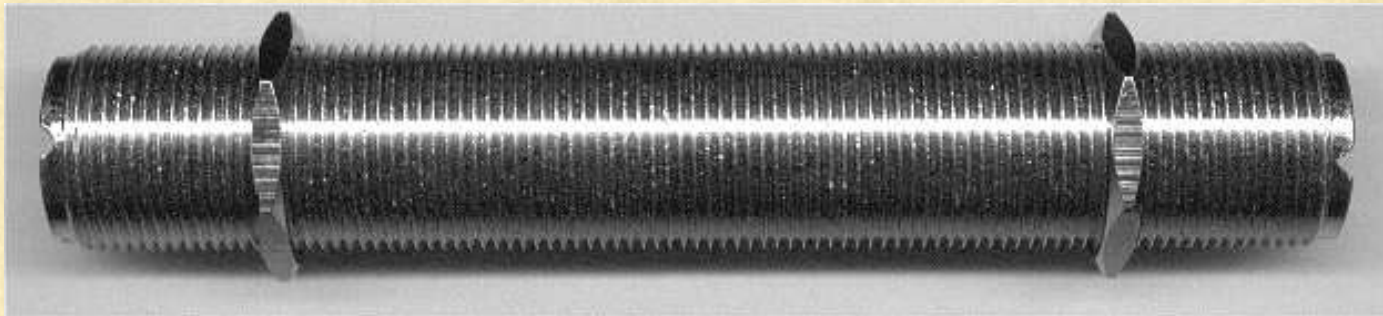

For bulkhead and through-the-wall UHF connector feed-thru connections, with keeper nuts.:

Order 7518-2 (Two inches)

\$ 2.95 ea.

[Order Now](#)



10 for \$ 24.50

[Order Now](#)



Order 7518-4 (Four inches)

\$ 3.95 ea.

[Order Now](#)



10 for \$ 34.50

[Order Now](#)



| | | | | |
|-------------------------------|-------------|---------------------------|------------------|---------------------------|
| Order 7518-6 (Six inches) | \$ 4.95 ea. | Order Now | 10 for \$ 44.50 | Order Now |
| Order 7518-8 (Eight inches) | \$ 8.95 ea. | Order Now | 10 for \$ 82.50 | Order Now |
| Order 7518-10 (Ten inches) | \$ 10.95ea. | Order Now | 10 for \$ 99.50 | Order Now |
| Order 7518-12 (Twelve inches) | \$12.95ea. | Order Now | 10 for \$ 114.50 | Order Now |

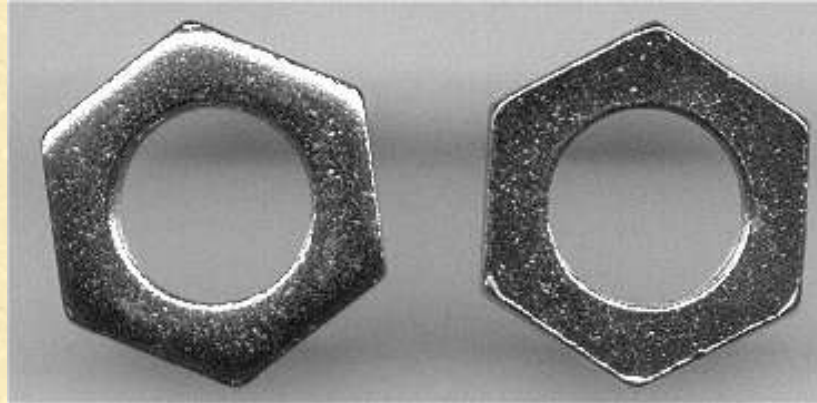

Heavy Duty (1") Nuts for the above bulkhead connectors.

2/.99 cents **HDM1-NUT** [Order Now](#) 10 for \$ 3.99 [Order Now](#)

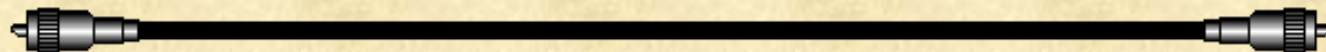

50 Ohm impedance, 3 ft, 6 ft, 9 ft, 12 ft, & 18 feet.

These jumpers are made from high quality, low-loss, coax cable with PL-259 connectors installed at each end.

| | | | | |
|---------------------------|-----------|-----------|--------|---------------------------|
| <u>Three ft. (3')</u> | ORDER No. | 8X3-PLPL | \$3.95 | Order Now |
| <u>Six ft. (6')</u> | ORDER No. | 8X6-PLPL | \$4.95 | Order Now |
| <u>Nine ft. (9')</u> | ORDER No. | 8X9-PLPL | \$5.95 | Order Now |
| <u>Twelve ft. (12')</u> | ORDER No. | 8X12-PLPL | \$7.95 | Order Now |
| <u>Eighteen ft. (18')</u> | ORDER No. | 8X18-PLPL | \$8.95 | Order Now |

BHF40M 40 METER 3/8" X 24 THREAD 8 feet long \$16.95

Add to Your
SHOPPING CART 

BHF20M 20 METER 3/8" X 24 THREAD 8 feet long \$16.95

Add to Your
SHOPPING CART 

BHF17M 17 METER 3/8" X 24 THREAD 8 feet long \$16.95

Add to Your
SHOPPING CART 

BHF15M 15 METER 3/8" X 24 THREAD 8 feet long \$16.95

Add to Your
SHOPPING CART 

BHF10M 10 METER 3/8" X 24 THREAD 8 feet long \$16.95

Add to Your
SHOPPING CART 

BHF6M 6 METER 3/8" X 24 THREAD 5 feet long \$16.95

Add to Your
SHOPPING CART 

Spare 48" Tips for above *tuneable-tip* antennas. TIP48, \$2.95

Add to Your
SHOPPING CART 



By combining a pair (two) of the single band HF Mobile (loaded) tuneable-tip antennas, and (VHF) whips at left, you can have an ideal, single element, horizontal dipole (beam). This type antenna opens the world of HF and VHF communications for the apartment dweller, RV HAM, field-day operating, and a variety of other uses and applications. Shown mounted on 1 & 1/4" mast. Antenna(s) Not Included.

\$16.95 each

Add to Your
SHOPPING CART 

DBLBRKT

tuneable-tip antennas allow adjusting for minimum VSWR.

[CLICK HERE to read more about our HF DIPOLE SPECIAL!](#)

By combining a pair (two) of the single band HF Mobile (loaded) tuneable-tip antennas above, you can have an ideal, single element, horizontal dipole (beam). This type antenna opens the world of HF communications for the *apartment dweller, RV HAM, field-day operating*, and a variety of other uses and applications. The packages described below include two antenna, the Double Antenna-Bracket (DBLBRKT), and mounting hardware

\$ 39.97 DBLSPCL (without BALUN) With BALUN, see "DBLCOMBO", below.

75 Meters →  , 40 Meters →  , 20 Meters →  ,

17 Meters →  , 15 Meters →  , 10 Meters →  ,

6 Meters → 

By combining a pair (two) of the single band HF Mobile (loaded) tuneable-tip antennas above, you can have an ideal, single element, horizontal dipole (beam). This type antenna opens the world of HF communications for the *apartment dweller, RV HAM, field-day operating*, and a variety of other uses and applications. The package described below includes two antenna, the Double-Bracket (DBLBRKT), mounting hardware, and **BUX**

BALUN (UNUN). SAVE \$\$\$\$\$, ADD the BUX UNUN , shown below, BOTH, DPLSPCL & BUXUNUN, for only \$ 54.97,

ORDER, DBLCOMBO

75 Meters →  , 40 Meters →  , 20 Meters →  ,

17 Meters →  , 15 Meters →  , 10 Meters →  ,

6 Meters → 

FAX 434 525 7818 or Mail order form, Click Here!

We accept:   

FAX 434 525 7818 or Mail order form, Click Here!

Web Page Design and HTML By
G. E. 'Buck' Rogers Sr K4ABT d/b/a BUX CommCo™® ©
Copyright © 1996-2004
All Rights Reserved

BUX CommCo™®
115 LUENBURG DRIVE
EVINGTON, VIRGINIA 24550

FAX 434 525 7818

"0043696"

6m Vertical Antenna

By Mike, G3JVL

The G3JVL 6M ground plane vertical is a compact antenna that is ideal for portable operations. It packs away into a small bag only 1.3 metres long which is an ideal size for hand-baggage on aircraft.

Although a little engineering work is required, it well within the abilities of the home workshop and all you newly licensed amateurs!

The vertical itself is constructed out of four overlapping sections of aluminium tube whose sizes are given in the diagram opposite. The four tubes are meant to telescope so wall thickness should be chosen to achieve this. In practice, 16swg or 1.6mm might be OK but 18swg or 1.2mm will easily fit. The lengths are held in place by three stainless steel self-tapping screws.

The vertical is bottom-loaded with a coil wound on an insulated former (nylon or similar material - it is not too critical at 50MHz). - the former is 130mm long with the top 20mm turned so it can be inserted into the bottom section of the vertical. The loading coil consists of ten turns of 16swg (1.6mm) diameter copper wire with one end connected to the bottom section of the vertical with a machine screw and the other end connected to the ground plate. A tap at 5-turns is connected to the input PL-259 socket.

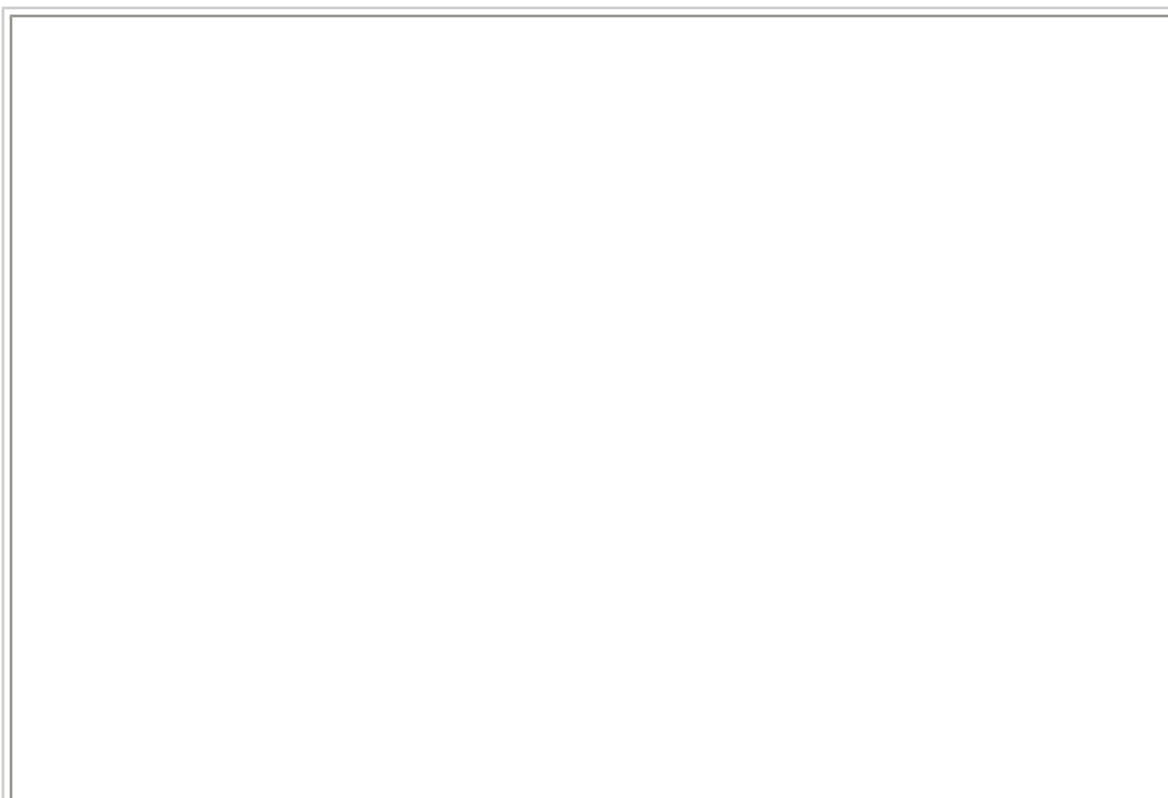

G3JVL 5/8 6M Vertical

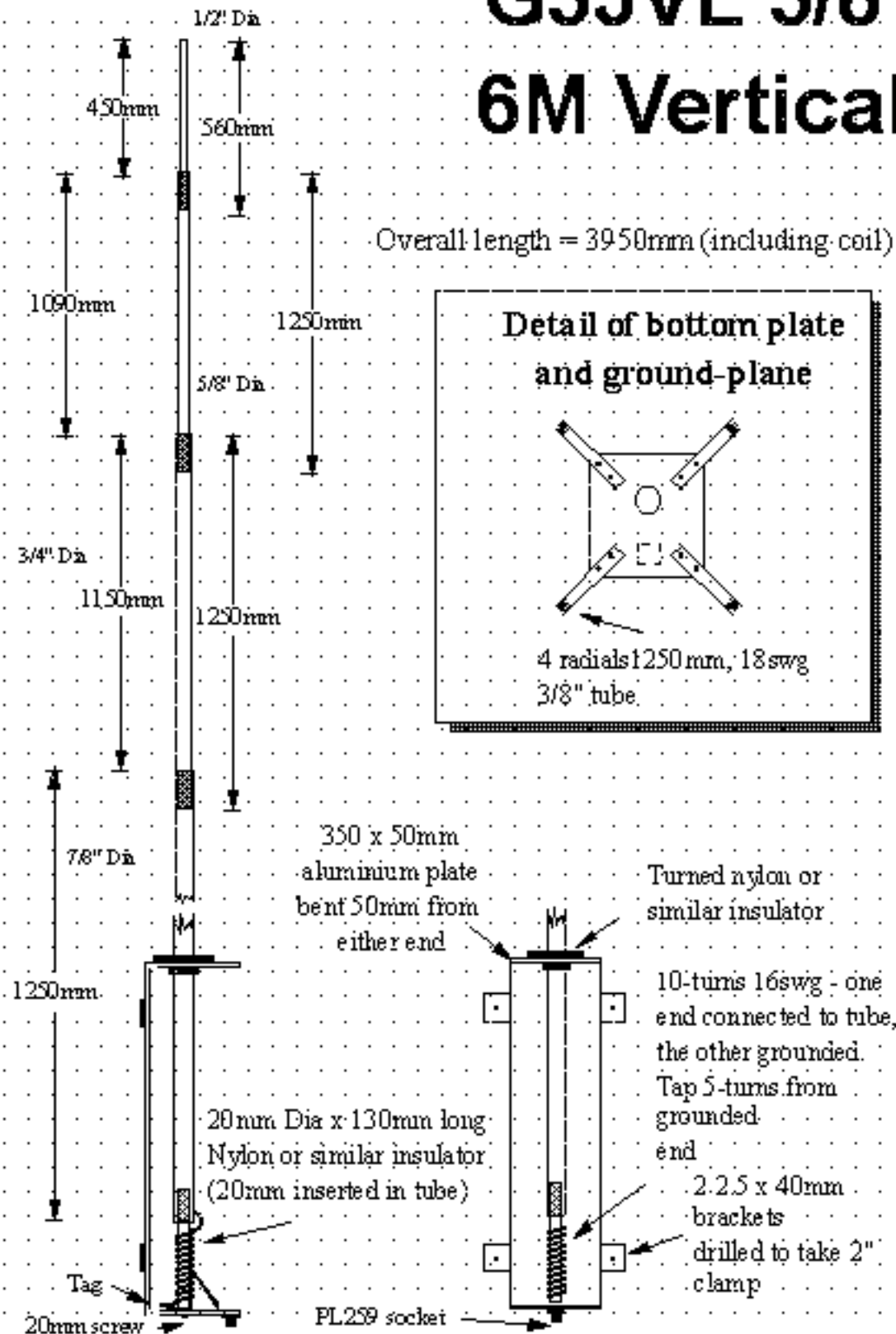

The construction of the 6m vertical antenna

The four ground plane elements are Constructed from 1250mm long, 9.5mm (3/8") diameter aluminium tube. These are mounted to the base plate by the use of eight

stainless steel machine screws. This arrangement allows easy disassembly.

The vertical itself is supported by a piece of 350mm by 50mm x 4mm aluminium plate bent into a 'U' shape. The bottom section of the vertical is insulated by a turned piece of nylon or similar tubing. If you do not have access to a lathe any other insulating arrangement should suffice so long as it is robust.

The overall length of the vertical is 3950mm including the loading coil. The top section should be trimmed to set the centre frequency. If the VSWR at resonance is not close to 1:1 then alter the position of the tap on the loading coil (remember, changing this will alter the resonance of the antenna!).

Once completed give the whole assembly several coats of varnish to keep out the weather.



[To return to the archive page click here](#)



free servers LOG IN



Get a
FREE
website!
[Click Here!](#)







NETZERO
High-Speed Internet
Dial-Up \$14.95
Internet Service \$9.95

The ON4ANT antenna page

An overview of interesting antenna designs and links to antenna sites.

Contents

-  [HF designs](#)
-  [6m designs](#)
-  [VHF designs](#)
-  [Commercial designs and links to designer software](#)
-  [Antenna pictures](#)
-  [My personal 6m site](#)

HF designs.

Several sites on the web carry very good information about antenna designing. One of the most interesting sites I've found is that of W4RNL, have a look t them. In the past i made a 5 band yagi, covering 20 to 10 meter band, with a boom length of 40-50-60ft.

This design was published in QEX a while ago. It has been reproduced successfully

by several hams around the world. This killer antenna was in use for our OT9E OT0E Contest station. We managed to win 3 times in a row the ARRL roundup as multi single.

[Contents.](#)

- ◆ A multiband yagi covering 10 to 20 meters.
- ◆ A 5el 10m beam (wideband design)
- ◆ A 5el 10m beam on a 6m boom

[Back to top](#)

6m designs

An overview of some really big yagis for 6 meters. For those with limited space there are some

short yagi designs available too.

[Contents.](#)

- ◆ 9 element yagi on a 15 meter boom
- ◆ 9 element yagi on a 12 meter boom using a folded dipole

[Back to top](#)

VHF designs

- ◆ under construction

[Back to top](#)

Commercial designs and links to designer software

◆ under construction

[Back to top](#)

Antenna pictures

◆ under construction

[Back to top](#)

A multiband yagi antenna

Design en construction ON4ANT-ON4GG

As most of us know, the monoband yagi is by far the best antenna choice.

The majority of hams have unfortunately no room to put up several towers

for all the different monobanders. The average ham chooses a trapped

multi-band yagi. This antenna type allows him to be active on a number of

bands, but it has some drawbacks as well: loss of swr bandwidth, antennagain

and F/B ratio. Over the past years a number of commercial interlaced designs

have been available. These designs often put 2 bands on a same boom.

These interlaced yagis often give a good result and can be an excellent replacement for the trapped yagis.

(The W4RNL web site carries an interesting article about these interlaced yagis).

Struggling to get a number of bands with good swr bandwidth and gain on a single boom made me decide to develop the antenna described here. The basic principle is to put a number of mono band yagis on the same boom, one in front of the other. The first conclusion is that the boom length increases rapidly, especially if one wants to cover 20 to 10 meters. The boom length was limited to 15 meters with an option to shorten the boom to 12.8 meters. This should allow most of us to reproduce the design. Those having plenty of room can go for the long design 18.3m (60ft) boom. The antenna covers the 20 to 10-meter bands.

The design has been done with the help of AO*, YO*, EZNEC/4*, STRESS*, and YAGI DESIGN*.

The electrical design can be found in [part 1](#).

It gives full details about element lengths and spacing. The feedpoint impedance, free space gain and swr bandwidths are also given. Two modified designs are described as well.

[Part 2](#) gives mechanical details, including the tapering detail, wind survival and total wind load.

[Part 3](#) gives a table with the gamma match details

[Part 4](#) gives you a table with gain figures from the most common available mono band yagis. These designs have been verified with the same software as used for designing this antenna. Trapped yagis have not been taken into account as these show less gain than their mono band counterparts and usually these trapped yagis have unrealistic gain figure claims.

[Part 1.](#)

The basic calculation has been done for an antenna in free-space and all values are in dBi.

We don't take into account the influence of the earth ground gain, and the reference antenna is an isotropic radiator. (0 dBd = 2.15 dBi). If one takes into account the ground gain (as most manufacturers do) the gain figures will be 4-5 dB higher.

However this is influenced by the antenna height.

The setup above real ground will change the radiation pattern.

The table gives the element length for a constant diameter (20mm) and the element spacing.

| Element Length | Description | Position (m) |
|----------------|-----------------------|--------------|
| 5.45 | Reflector 20 | 00.00 |
| 5.2 | Driver 20 | 02.00 |
| 4.9 | Director 20 | 03.60 |
| 4.15 | Reflector 17 & dir 20 | 05.25 |
| 4.02 | Driver 17 | 06.20 |
| 3.8 | Reflector 15 & dir 17 | 07.20 |

| | | |
|-------|-----------------------|-------|
| 3.395 | Driver 15 | 08.40 |
| 3.02 | Director 15 & ref 12 | 09.50 |
| 2.91 | Driver 12 | 10.30 |
| 2.78 | Reflector 10 & dir 12 | 11.60 |
| 2.55 | Driver 10 | 12.45 |
| 2.355 | Director 10 | 13.40 |
| 2.265 | Director 10 | 15.00 |

What is to expect from this antenna?

Gain is comparable to a 3-4-element monobander, with excellent swr bandwidth and F/B.

Antenna specifications.

Frequency Gain (dBi) Impedance F/B SWR

| | | | | |
|--------|-----|------------|------|------|
| 14.000 | 8.1 | 33.0-j4.1 | 26.8 | 1.26 |
| 14.175 | 8.2 | 30.9+j3.0 | 29.1 | 1.00 |
| 14.350 | 8.3 | 26.0+j12.2 | 25.9 | 1.44 |
| 18.068 | 8.1 | 20.9-j3.6 | 21.5 | 1.10 |
| 18.118 | 8.6 | 22.3-j2.3 | 22.3 | 1.00 |
| 18.168 | 8.6 | 23.5-j1.2 | 23.2 | 1.07 |
| 21.000 | 8.4 | 32.4-j7.8 | 21.1 | 1.27 |
| 21.200 | 8.5 | 34.2+j0.5 | 21.0 | 1.00 |
| 21.400 | 8.6 | 35.7+j8.1 | 20.9 | 1.25 |

| | | | | |
|--------|-----|------------|------|------|
| 24.880 | 8.5 | 10.7-j3.6 | 30.6 | 1.19 |
| 24.940 | 8.5 | 10.8-j1.7 | 30.6 | 1.00 |
| 24.990 | 8.5 | 10.8+j0.1 | 28.0 | 1.19 |
| 28.000 | 7.9 | 26.0-j7.2 | 29.7 | 1.47 |
| 28.350 | 8.1 | 26.9+j3.1 | 25.7 | 1.00 |
| 28.700 | 8.2 | 27.6+j13.9 | 22.6 | 1.48 |

This design has an almost constant gain over the 5 bands.

The swr bandwidth is excellent over the entire range with exception of 10 meters;

here it is limited to 28.8 MHz. Of course this swr is in reference to the matching frequency.

I'm sure that things still can be improved, but this may have a negative influence on swr

bandwidth and/or F/B. Another disadvantage of getting the last .5 dB out of the design makes it more critical and less tolerant for small dimension errors (element lengths and spacing).

If you really want more gain, go for the longer design on the 18m boom. You will get the same bandwidth and F/B (or even better) with higher gains.

[Variant 1.](#)

A 15-meter boom too big for you? Perhaps this 12.8m antenna is the solution.

There will be one element less on 20m. The gain will drop to about 7 dBi, which is still good.

Element length (m) Description Position (m)

5.45 Reflector 20 0.00
 5.2 Driver 20 2.00
 4.15 Reflector 17 and director 20 3.05
 4.02 Driver 17 4.00
 3.8 Reflector 15 and director 17 5.00
 3.395 Driver 15 6.20
 3.02 Director 15 and reflector 12 7.30
 2.91 Driver 12 8.10
 2.78 Reflector 10 and director 12 9.40
 2.55 Driver 10 10.25
 2.355 Director 10 11.20
 2.265 Director 10 12.80

Only 20m changes, they other gain figures remain.

Antenna specifications.Frequency Gain (dBi) Impedance F/B SWR

—
 14.000 7.2 33.5-j11.6 16.0 1.40

14.175 7.1 39.8-j0.9 29.1 1.00

14.350 7.0 45.3+j9.0 14.3 1.30

Variant 2.

Do you have plenty of room? This 18.3m monster is the solution.

It gives you higher gain on the top 3 bands with an excellent bandwidth.

Element length (m) Description Position (m)

5.45 Reflector 20 0.00

5.2 Driver 20 2.00

4.9 Director 20 3.60

4.15 Reflector 17 and director 20 5.25

4.02 Driver 17 6.40

3.8 Reflector 15 and director 17 7.20

3.395 Driver 15 8.40

3.02 Director 15 and reflector 12 9.50

2.91 Driver 12 10.80

2.68 Reflector 10 and director 12 12.00

2.55 Driver 10 13.014

2.47 Director 10 13.816

2.44 Director 10 15.775

2.31 Director 10 18.25

—

Antenna specifications.

—

Frequency Gain (dBi) F/B

—

14.175 8.3 34

18.118 8.3 21

21.200 8.7 23

24.940 9.6 38

28.350 10.0 29

This design made it at my home QTH.

The calculated specification seem to be corresponding really well with the on air performance.

Initial testing show an advantage as compared to a very large commercial multi band yagi.

The design is very broadband and allows different kinds of matching.

—

Part 2.

—

Feeding the antenna.

The driven elements are all resonated in band.

The actual impedance of the antenna is high enough to allow different kind of feeding.

Personally I use a gamma match; the elements don't need to be spliced up in this case.

[Element mounting.](#)

One can choose isolated or non-isolated element mounting. The boom influence on the element length is minimal.

The use of isolated element can be a disadvantage is you want to use your tower as a toploaded vertical on 160m. (* [ON4UN](#)).

The boom element plate measures 200x100mm. If you wish to mount the elements non-isolated you can calculate the

influence of the boom on the element lengths with [YAGI DESIGN*](#).

The calculated influence is only a few millimeters for the 20m element. As this design is not critical, one can use the isolated element lengths.

[Element tapering.](#)

Each element has to be as strong as possible for a minimal windload and weight so we use tapering.

Most of the available antenna design software programs allow calculating the taper. Only a few allow calculating the element strength.

Initially I used **STRESS***, this software is used by the former Telex/Hygain company.

Afterwards I used a Belgian product, **YAGI-DESIGN*** by ON4UN. This package can calculate in all circumstances the taper of an

element that complies with a wind survival. This for the lowest possible weight and windload. The element sag is also calculated.

The calculated minimal wind survival is 160km/h, (100mph). The antenna is mounted on an 80ft tower on top of a 300ft hill here.

Parameters: EIA-222-C pressure 30lb/sq ft at 86mph.

Shape factor .666

No ice-load

Aluminum 6061-T6 (yield strength 35000)

The table gives us element diameter, wall thickness, length, half element weight and length. The elements will be adjusted with the tip end.

Some of these elements are telescopic on the inside. All of the 20m element consist of 3 diameters.

—

[Element 1-2-3](#)

1700x28x1.5 3000x25x2.5 2750x19x1.5

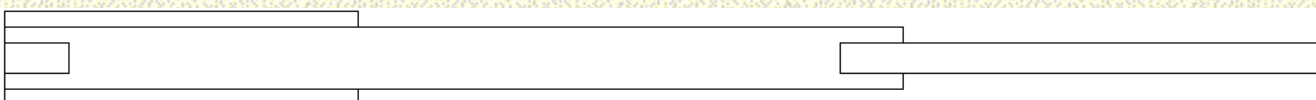

Insert 250x19x1.9

The wind load of this half element is 0.13m^2 . The weight of this half element is 2.6kg

Element sag is 20.5cm. The tip will be adjusted.

Tip lenght ! (100mm overlap)

Isolated Non-isolated

Element 1 : 2567mm 2570mm

Element 2 : 2309mm 2312mm

Element 3 : 1998mm 2000mm

Element 4-5-6

1750x25x2.5 **x19x1.5

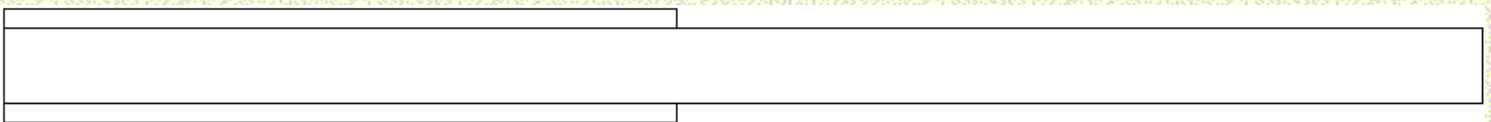

The wind load of this half element is 0.084m^2 . The weight of this half element is 1.85kg

Element sag is 8.4cm. The tip will be adjusted

Total element length !

Isolated Non isolated

Element 4 : 4222mm 4224mm

Element 5 : 4053mm 4056mm

Element 6 : 3852mm 3854mm

Element 7-8-9

1500x25x2.5 ****x19x1.5

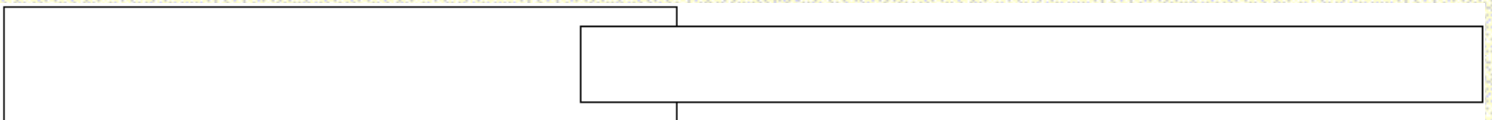

The wind load of this half element is 0.074m². The weight of this half element is 1.2kg

Element sag is 6cm. The tip will be adjusted

Total element length ! (100mm overlap)

Element 7 : 3450mm

Element 8 : 3082mm

Element 9 : 2957mm

Element 10-11-12-13

750x25x2.5 **x19x1.5

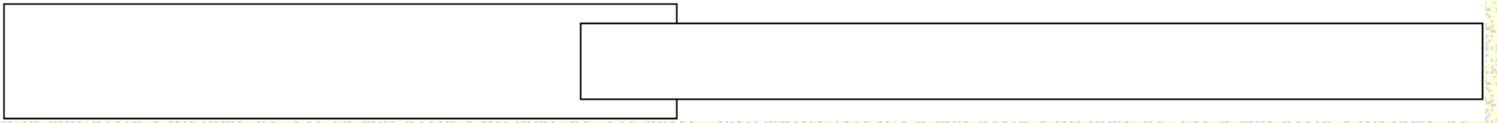

The wind load of this half element is 0.059m². The weight of this half element is 1.1kg

Element sag is 3.5cm. The tip will be adjusted

Total element length ! (100mm overlap)

Element 10 : 2845mm

Element 11 : 2583mm

Element 12 : 2364mm

Element 13 : 2264mm

Wind load and weight of elements.

44.55 kg and a 2.20 m² windload.

If you choose the variant 1 you will have 0.26m² less wind load and will gain about 5.2 kg.

The actual weight of the antenna is function of the choosen boom diameter, the mounting plates and all related hardware.

My antenna uses a 4 inch boom and the weight is around 60 kg.

Part 3.

The Gamma match for the 18.3 m version

| | A(mm) | B(mm) | C(pF) | D(mm) | D(mm) |
|--------|-------|-------|-------|-------|-------|
| 14.175 | 1067 | 120 | 180 | 28 | 4 |
| 18.118 | 562 | 120 | 150 | 25 | 4 |
| 21.200 | 735 | 100 | 100 | 25 | 4 |
| 24.930 | 867 | 100 | 100 | 25 | 4 |
| 28.400 | 361 | 100 | 81* | 25 | 4 |

* (3x27pf parallel)

The Gamma match for the 15 m version

| | A(mm) | B(mm) | C(pF) | D(mm) | D(mm) |
|--------|-------|-------|-------|-------|-------|
| 14.175 | 950 | 120 | 180 | 28 | 4 |
| 18.118 | 602 | 120 | 180 | 25 | 4 |
| 21.200 | 631 | 110 | 100 | 25 | 4 |
| 24.930 | 522 | 80 | 270 | 25 | 3 |

| | | | | | |
|--------|-----|-----|-----|----|---|
| 28.400 | 496 | 100 | 100 | 25 | 4 |
|--------|-----|-----|-----|----|---|

The Gamma match for the 12.8 m version

| | A(mm) | B(mm) | C(pF) | D(mm) | D(mm) |
|--------|-------|-------|-------|-------|-------|
| 14.175 | 880 | 120 | 154 | 28 | 4 |
| 18.118 | 598 | 120 | 200 | 25 | 4 |
| 21.200 | 629 | 100 | 111 | 25 | 4 |
| 24.930 | 279 | 100 | 190 | 25 | 3 |
| 28.400 | 497 | 100 | 100 | 25 | 4 |

For an output power of 2000 watts one should get capacitors handling 300 volts and 6.3 amps current.

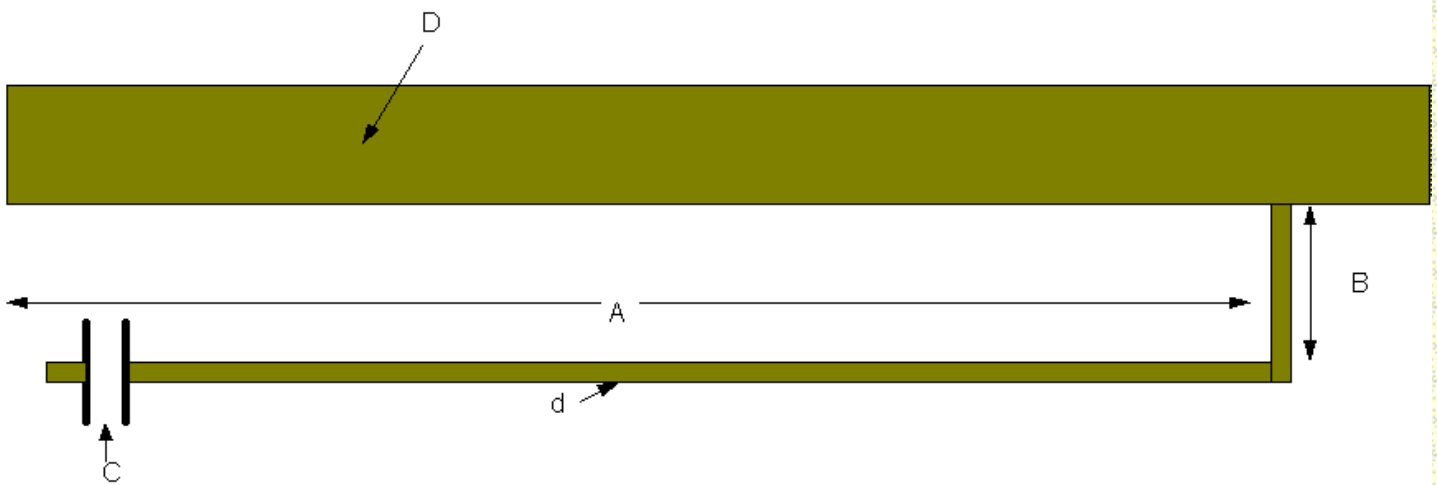

The Hairpin match for the 18 m version

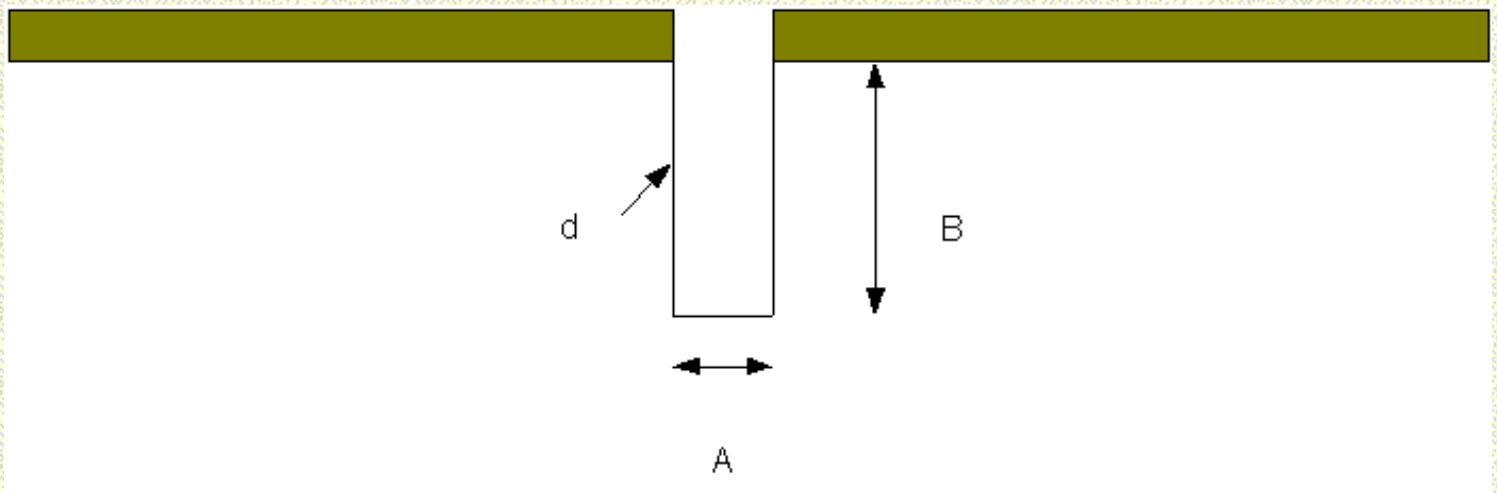

| | A(mm) | B(mm) | d(mm) | Shorten driven element |
|--------|-------|-------|-------|------------------------|
| 14.175 | 50 | 541 | 4 | 139mm |
| 18.118 | 50 | 393 | 4 | 56mm |
| 21.200 | 50 | 407 | 4 | 88mm |
| 24.940 | 50 | 235 | 4 | 87mm |
| 28.500 | 50 | 317 | 4 | 103mm |

Part 4.

Is it all worth the trouble ? Looking at the actual cost, YES. The price should be below \$800 (US) for the 60ft design.

The design is non-critical can can be easily reproduced. The gain is excellent and you will have a big signal on the bands.

However, an antenna this size requires a strong tower and big rotator. If you have the tower and rotator for it, its an excellent choice.

A comparison with some commercial mono band antennas gives you a idea about the performance of this antenna.

The values indicated are NOT those from the manufacturer, but those calculated with the design software used for this antenna.

Only this procedure gives an objective view on the gain, since all gains were computed in exactly the same way.

dbi

Type Gain SWR bandedge Description

310-08 7.17 1.31-1.46 3el 10m on 2.3m boom

103BA 7.51 1.53-2.01 3el 10m on 2.3m boom

153BA 7.68 1.45-1.68 3el 15m on 3.5m boom

315-12 7.54 1.49-1.45 3el 15m on 3.6m boom

320-16 7.21 1.27-1.38 3el 20m on 4.7m boom

203BA 7.17 1.22-1.20 3el 20m on 4.8m boom

20-3CD 8.09 2.03-2.90 3el 20m on 6.0m boom

10-4CD 8.58 1.63-1.79 4el 10m on 4.8m boom

412-15 8.40 1.09-1.09 4el 12m on 4.4m boom

415-18 8.24 1.41-1.38 4el 15m on 5.4m boom

417-20 8.52 1.08-1.11 4el 17m on 6.0m boom

204CA 8.25 1.49-1.47 4el 20m on 7.8m boom

420-26 8.60 1.28-1.37 4el 20m on 7.8m boom

20-4CD 8.54 1.78-2.20 4el 20m on 9.6m boom

510-20 9.75 1.49-1.53 5el 10m on 6.0m boom

KLM510 9.21 1.33-1.43 5el 10m on 6.1m boom

105CA 8.38 1.42-1.23 5el 10m on 7.2m boom

155CA 9.70 1.49-1.62 5el 15m on 7.7m boom

205CA 9.23 1.43-1.96 5el 20m on 10.4m boom

KLM520 9.43 1.66-1.25 5el 20m on 12.8m boom

Conclusion.

This design is a valuable alternative for a 4 element monoband yagi, taking into account the gain and swr bandwidth.

It is obvious that some improvements can be done, depending on your specific needs. Perhaps you need less bandwidth.

I tried to have a broadband yagi with gain figures close too or better than the common 4 element moband yagis.

The real gain, with associated radiation angle is given in next table.

14.150 13.55 dBi @ 12°

18.118 13.64 dBi @ 10°

21.200 13.74 dBi @ 8°

24.940 14.20 dBi @ 7°

28.400 13.77 dBi @ 6°

If you wish more info on this design, or want to share some of your antenna experiences, you can always email me ON4ANT@hotmail.com

References

AO and YO written by K6STI.

Comparison of this design made by W4RNL with EZNEC4 shows very similar results to those obtained with AO.

The W4RNL site contains lots of valuable antenna information and really is worthwhile visiting.

My sincere thanks to L.B. Cebik for the verification of this design and the information available on his website.

YAGI DESIGN was written by ON4UN and covers all mechanical issues of antennas. It's a DOS based program,

and is extremely easy to use. I wish to thank John for his help as well. Those wishing to obtain this program can

always contact John, ON4UN

STRESS Hygain/Telex.

[Back to top](#)

A 5 element yagi for 10 meters

(Wide band design)

Here is a very simple 5 element covering the entire 10 meter band (28.000-29.700) with a swr of less than 1.4 at the band edges. The elements are non tapered! Element diameter is 11 mm.

| | Position (mm) | Half element (mm) |
|------------|---------------|-------------------|
| Reflector | 0 | 2670 |
| Driven | 1014 | 2530 |
| Director 1 | 1816 | 2400 |
| Director 2 | 3775 | 2370 |
| Director 3 | 6250 | 2250 |

Here is the overview of freespace gain compared to an isotropic source. SWR reference is 28.500 MHz.

| Freq. | Gain(dBi) | F/B | Impedance | SWR |
|--------|-----------|------|-----------|------|
| 28.000 | 9.3 | 16.8 | 31.3-j9.0 | 1.35 |
| 28.500 | 9.5 | 21.1 | 37.4-j0.5 | 1.00 |

| | | | | |
|--------|-----|------|-----------|------|
| 29.000 | 9.8 | 21.5 | 38.7+j7.8 | 1.25 |
| 29.700 | 9.8 | 23.0 | 28.6+j3.3 | 1.35 |

Seen the high impedance, several matching methods are possible.

What happens if we use 20mm elements?

| Freq. | Gain(dBi) | F/B | Impedance | SWR |
|--------|-----------|------|-----------|------|
| 28.000 | 9.5 | 17.9 | 31.3-j6.1 | 1.26 |
| 28.500 | 9.8 | 22.3 | 34.1+j0.7 | 1.00 |
| 29.000 | 10.0 | 22.5 | 36.4+j9.2 | 1.28 |
| 29.700 | 9.5 | 25.3 | 10.2+j9.1 | 3.56 |

Bandwidth has been reduced!! So probably you will need to re-dimension the yagi.

Lets consider a boom-element plate of 100x200mm. On the version with the 20mm element..

We start of with a saddle height of 10mm, element is mounted 10mm above the plate with U bolts).

The equivalent element diameter for the part above the plate (a length of 100mm that is) has an

equivalent element diameter of 46.4 mm. So when modelling the yagi with the plate, one has to consider

The element as being tapered, a 100mm long 46mm element in the middle and the rest a

20mm element.

The boom diameter itself has no more influence on the equivalent element diameter. (if insulated)

Now we are going to verify the influence of the saddle height on the equivalent element diameter!

| Saddle height | Equivalent element diameter |
|---------------|-----------------------------|
| 5mm | 42.4mm |
| 7mm | 44.0mm |
| 9mm | 45.6mm |
| 10mm | 46.4mm |

Gamma matching.

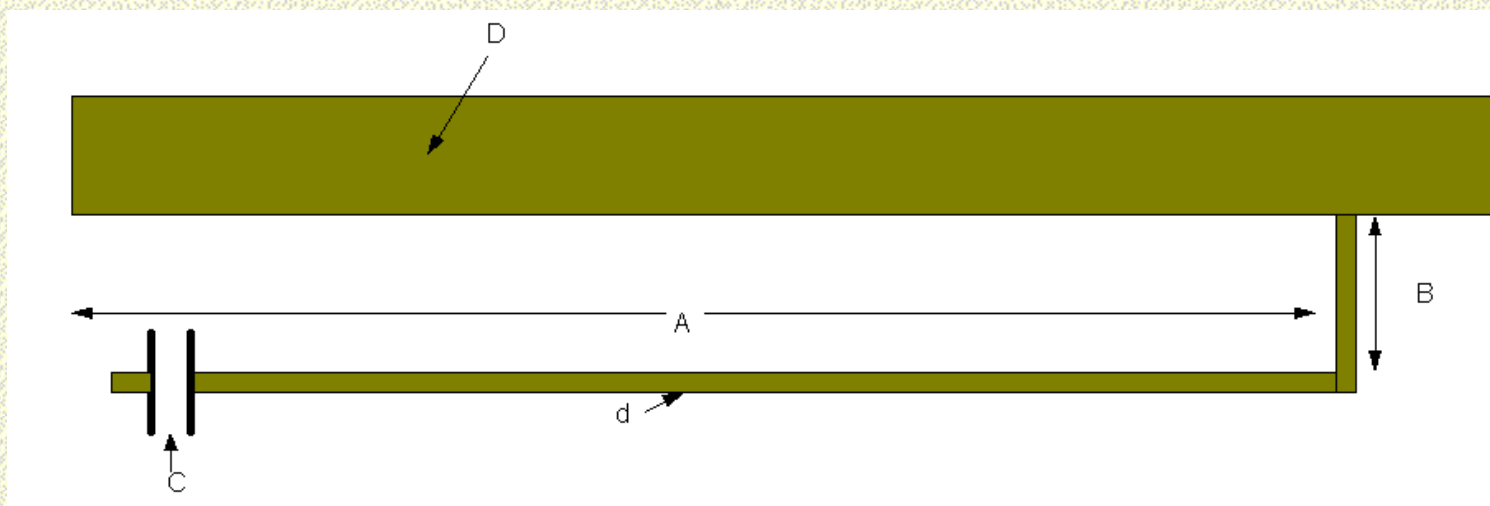

$$d = 4 \text{ mm}$$

$$D = 20 \text{ mm}$$

$$A = 420 \text{ mm}$$

$$C = 100 \text{ pf}$$

$$B = 100 \text{ mm}$$

Hairpin matching.

If a hairpin is used the driven element needs to be shortened by **10.5 cm !**

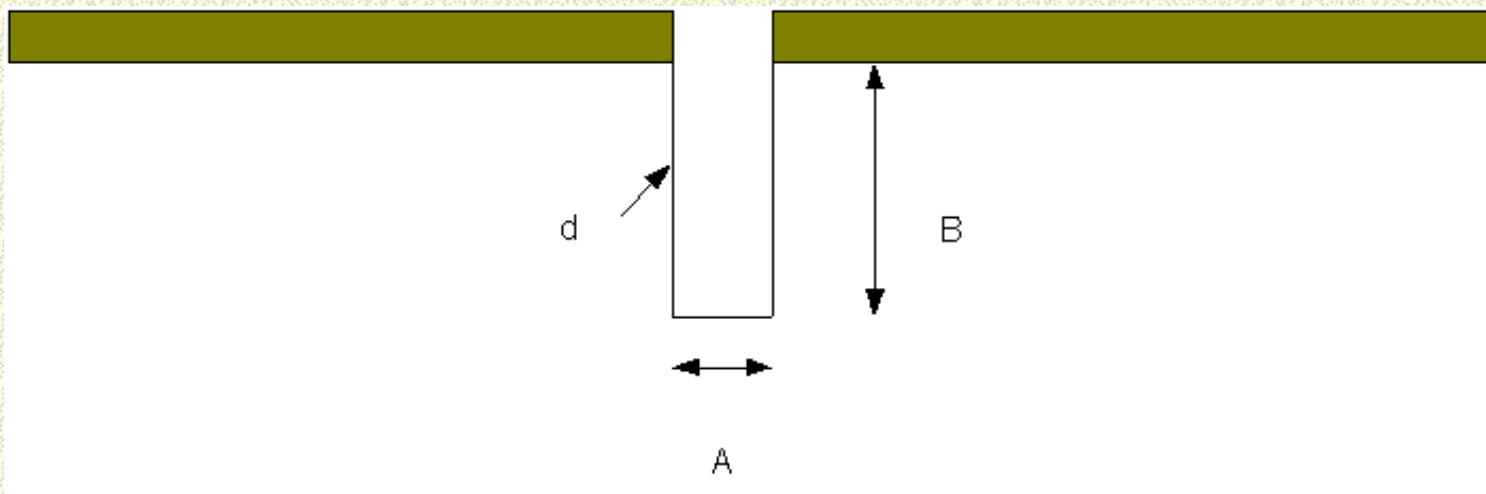

$$A = 50 \text{ mm}$$

$$B = 360 \text{ mm}$$

$$D = 4 \text{ mm diameter}$$

[Back to top](#)

A 5 element yagi for 10 meters

On a 6m boom. (standard length)

This economical design uses a standard 6 meter long square boom (50x50x1.5mm).

The boom-element plate is a 5mm thick 200x100mm plated bolted to the boom.

The elements are bolted to this plate. (no saddles)

Matching is achieved with a hairpin, so the driven element is insulated from the plate.

A rubber water tube with an inner diameter of 20mm will do fine, and use 2 u bolts to fix this element. The element diameter is 20x1mm

| | Position (mm) | Half element lengths (mm) |
|------------|---------------|---------------------------|
| Reflector | 0000 | 2670 |
| Driven | 1000 | 2459* |
| Director 1 | 1750 | 2420 |
| Director 2 | 3460 | 2380 |
| Director 3 | 5950 | 2190 |

* the element is shortened to accommodate the hairpin (was 2530mm before)

| | 28.000 | 28.500 | 29.000 | 29.400 |
|------|-----------|-----------|-----------|-----------|
| Gain | 9.31 | 9.5 | 9.6 | 9.5 |
| F/B | 20.4 | 22.7 | 22.7 | 22.9 |
| Imp. | 26.9-j7.9 | 31.2+j1.0 | 36.5+j6.0 | 22.8-j0.8 |
| SWR | 1.34 | 1.07 | 1.3 | 1.3 |

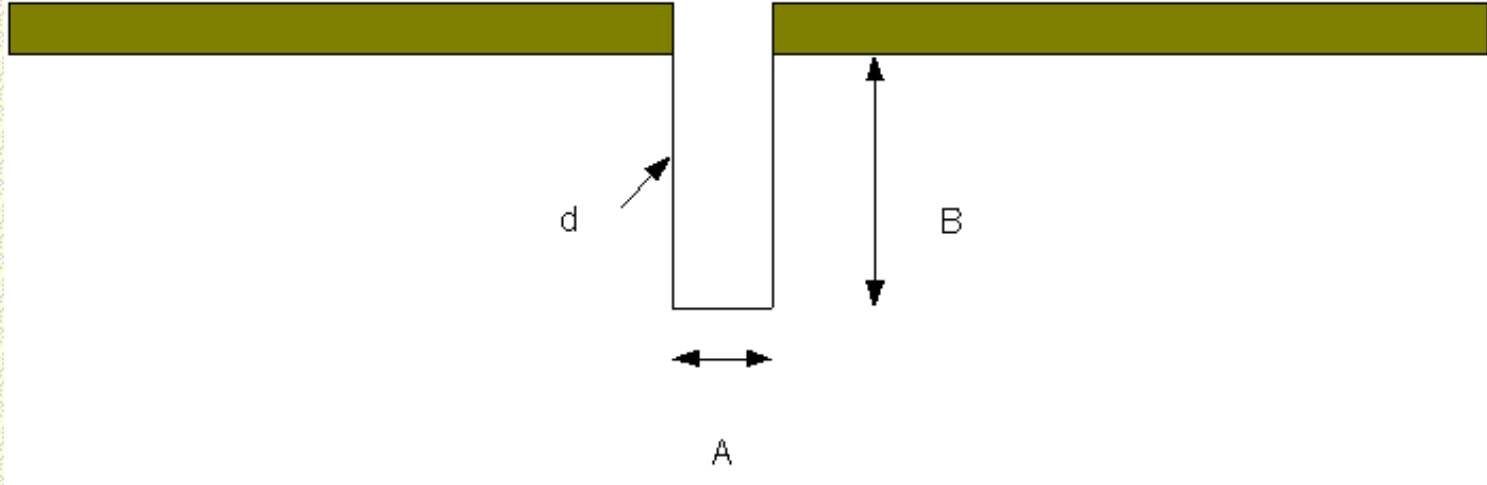

A = 50 mm

B = 271 mm

D = 4 mm diameter

[Back to top](#)

A 9 element yagi on a 15m boom

(a 50 MHz yagi with 15.0 dBi gain)

Having lots of space for antenna I started out with a design for a long yagi, 9 elements on a 15 meter boom.

I did not choose to go for a folded dipole, but rather stick to a minimum value for the feed impedance.

Table : Element length versus position. Element diameter is 12 mm.

| Position (mm) | Length (mm) |
|----------------------|--------------------|
| 0.0000 | 144.9851 |
| 91.5139 | 135.0005 |
| 163.0316 | 135.4751 |
| 163.0316 | 133.1443 |
| 531.7224 | 130.1802 |
| 780.1813 | 128.3098 |
| 1037.0823 | 127.7031 |
| 1273.9320 | 128.1430 |
| 1489.3116 | 130.1693 |

Table : Gain, F/B, SWR and impedance versus frequency.

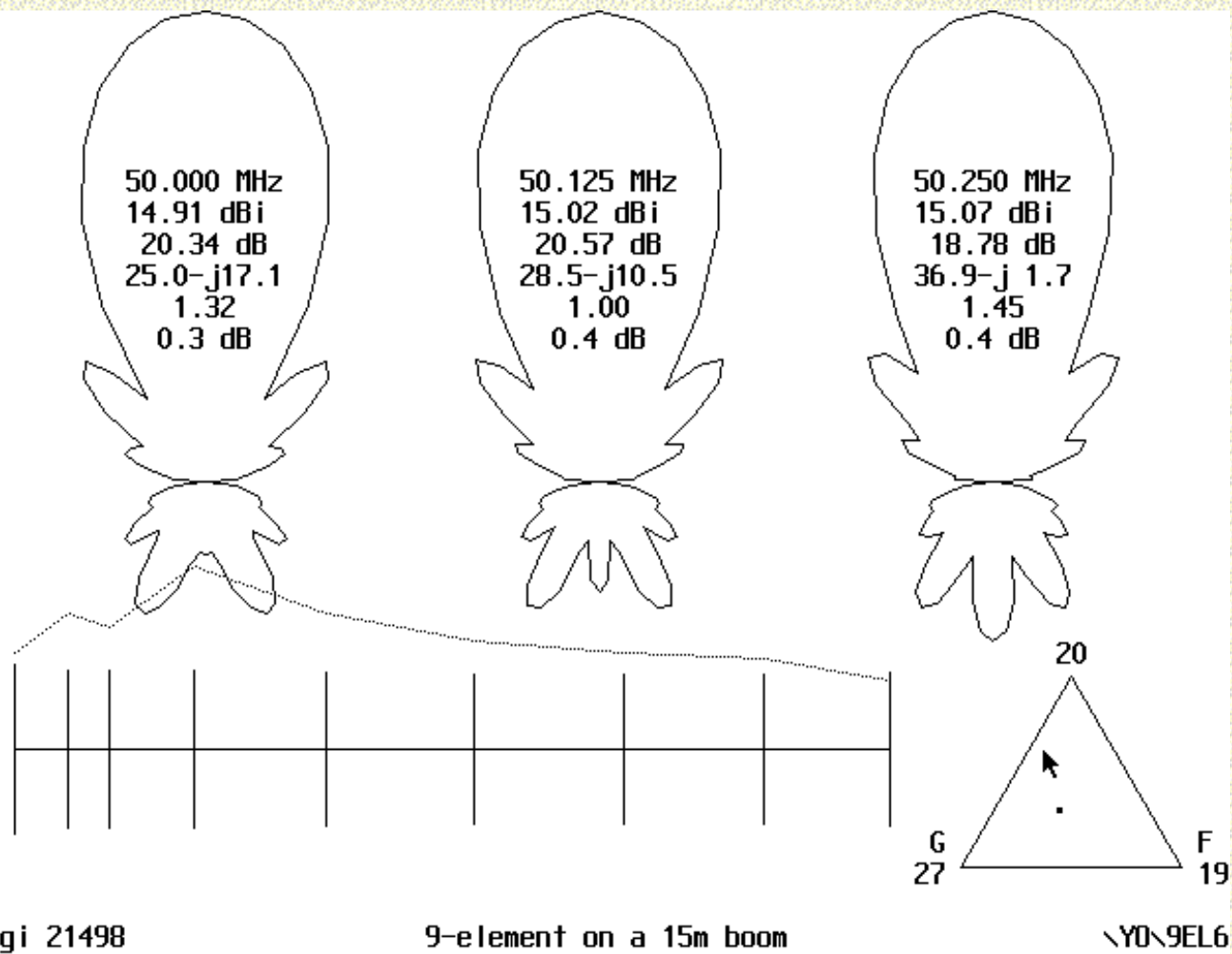

A total gain of 15.0 dBi, this out performs the DL6WU designs by a few tenths of a dB.

It outperforms the commercial M2 design as well with 0.15dB.

(6M9KHW !, the older 9 element, a 2 WL, is 1 dB down)

The impedance remains reasonable and allows for different feed methods.

[Back to top](#)

A 9 element yagi on a 12m boom

(a 50 MHz yagi with 14.1 dBi gain)

If one wants a very simple feed like a folded dipole with a 4:1 coaxial balun, you can opt for for this design.

Lower gain (14.1dBi) but excellent match.

Table : Element position versus element length

| Position(mm) | Half element length |
|--------------|---------------------|
| 0 | 1450 |
| 1400 | 1420 |
| 1966 | 1368 |
| 3170 | 1350 |
| 4700 | 1320 |
| 6450 | 1320 |
| 8510 | 1318 |
| 10640 | 1298 |
| 12840 | 1298 |

This very 'easy' design has a free space gain of 14.1 dBi. The element diameter is 12mm.

The values given in the table do not take into account the influence of the boom.

There are some formulas to calculate the influence of the boom on isolated elements going through it.

Have a look at <http://www.dubus.org> for valuable info on antenna designs for 6-2-70-

23.

Table : Gain, F/B, SWR and impedance versus frequency.

| | 50.000 | 50.150 | 50.300 | 50.450 |
|-------------------|-----------|-----------|-----------|----------|
| Gain (dBi) | 14.04 | 14.10 | 14.12 | 14.08 |
| F/B (dB) | 20.32 | 20.84 | 20.09 | 17.01 |
| Impedance | 43.6-j2.2 | 49.3+j0.5 | 57.9-j0.8 | 65.9-j11 |
| SWR | 1.16 | 1.01 | 1.16 | 1.28 |

[Back to top](#)

Last Revised: September 2000



The UKSMG Six News Archives

[home](#) > [archive](#) > [6m antennas](#)



Thanks to all of our authors since 1982!

| 6m antennas | issue |
|--|--------------------------|
| 6m power splitters | 33, <i>January 1992</i> |
| 6m groundplane vertical antenna design | 33, <i>April 1992</i> |
| zen and the art of stacking | 34, <i>July 1992</i> |
| low loss japanese coaxial cable | 35, <i>October 1992</i> |
| a hairpin match for the 5-element tonna | 35, <i>October 1992</i> |
| a comparison of commercial 6m antennas | 35, <i>October 1992</i> |
| optimised six-metre yagi | 39, <i>October 1993</i> |
| a small yagi for 50MHz | 50, <i>August 1996</i> |
| a long-wire aerial for six metres | 56, <i>February 1998</i> |
| an indoor loop antenna for 6m | 56, <i>February 1998</i> |
| the ZR6YY antenna for 6m | 56, <i>February 1998</i> |
| azimuth precision - knowing your Yagi! | 57, <i>May 1998</i> |
| the gain of aerials: the myths explained | 58, <i>August 1998</i> |
| a loft-yagi for six metres | 58, <i>August 1998</i> |
| half bobtail antenna | 60, <i>February 1999</i> |
| a three element quad (plus a 2ele) | 61, <i>May 1999</i> |
| a review of the M2 6M7JHV antenna | 61, <i>May 1999</i> |
| a vertically-polarised VK2ABQ antenna | 61, <i>May 1999</i> |
| further notes on the G8VR small yagi | 63, <i>November 1999</i> |
| the 'zigzag' vertical beam | 64, <i>February 2000</i> |
| stacking for 50MHz | 65, <i>May 2000</i> |
| a 10-element yagi antenna for six | 67, <i>November 2000</i> |
| vertical and above Part 1 | 70, <i>August 2001</i> |
| vertical and above Part 2 | 70, <i>August 2001</i> |

[Bits & Pieces](#)
[history of 6m](#)
[6m equipment](#)
[how to work 6m DX](#)
[propagation theory](#)
[6m DXpeditions](#)
[interesting stuff](#)
[6m ops remembered](#)



**COFFEE MUGS
BANNERS
FLAGS and PENS
BUTTONS**

**D. B. C.
Advertising**

<http://www.dbcadvertising.com/>

Custom orders OK!

Click on the banner

© Lowell Enterprises



6 TECH LIST

MOD-----TECH-----FILES NEEDED

SEND VIA EMAIL TO: sixclub@6mt.com

© Lowell Enterprises

VHF/UHFMESSAGE BOARD

50MHZ

ORIGINAL ARTICLE TO THE INTRODUCTION OF GRID SQUARES

(QST 1-93) [gsqua.zip](#)

INTRODUCTION TO THE WORLD ABOVE 50MHZ (QST 11-77) [intf.zip](#)

"AM - 33" CONVERSION FOR 6 AND 2 [c14.zip](#)

AEA

DX HANDY MX 6-S (SSB/CW HANDHELD) OPERATING MANUAL -----[aeadxhandy.zip](#)

ALINCO

ALINCO TX AND RX MOD DR-M06T (VE3JKB) [alinco.zip](#)

ALINCO 6MT MOD FOR THE DX70 [dx70.zip](#)

AMECO

AMECO 6 & 2 MANUAL [ameco.zip](#)

AMECO VFO 6/2/220 MANUAL [amecov.zip](#)

CB CONVERSIONS

CB TO 6 -- KB5LF'S HY-GAIN CONVERSION [hycbc.zip](#)

CB TO 6MT (73 6-80) [f36.zip](#)

PEARCE SIMPSON CONVERSION TO 6MT SSB (KD4NUE) [pearce.zip](#)

*CB TO SIX METRES BY SHAWN BARIS ZR1EV [zscb.zip](#)

CHEROKEE

CHEROKEE AH-50 MANUAL [ah50.zip](#)

COLLINS

6MT CONVERSION COLLINS KWM1 (QST 11-59) [f43.zip](#)

CUSHCRAFT

CUSHCRAFT A50-5 MODS [CCA50-5S-KM1H.pdf](#)
CUSHCRAFT 6 METER SQUALO MODEL NO. ASQ-6 [squalo.zip](#)
CUSHCRAFT 5ELE-4ELE CONVERSION (N8ZJN) [cush.zip](#)
CUSHCRAFT 5ELE MODS EXTENDED BOOM OPTIMIZED [A50-5s_w5wvo.pdf](#)

DENTRON

DENTRON CLIPPERTON V MOD FOR 6MT [dentn.zip](#)

© Lowell Enterprises

HEATHKIT

SB220 MODS (NOTES FROM M0BCG) [sb220](#)
FINAL TUNING KNOB FOR THE HEATH SIXER AND TWOER (QST 1-67) [f46.zip](#)
MOD FOR THE HEATH SIXER (HORIZONS 11-62) [c3.zip](#)
SB1000 ON 6MT [d6.zip](#)
USING THE SB200 ON 6MT (QST 1-69) [sbs.zip](#)
CIRCUIT IMPROVEMENTS FOR SB220 AMP PART 1 (QST 11-90) see below
-----PART 2 (QST 12-90) [sbim.zip](#)
SB 220 MOD (QST 5-89) [sbmod.zip](#)
SB 220 IMPROVEMENTS (QST 2-89) [sbtm.zip](#)
SB 110 MOD (K0CQ) [k0cq.zip](#)
SB 10 ON 6MT [sbtn.zip](#)
SB 220 ON 6MT [sbttts.zip](#)

© Lowell Enterprises

HENRY

HENRY MANUAL AND SCHEMATIC FOR THE 2002A, 2004A, 2006A [henry.zip](#)

HI-PAR

HI-PAR SATURN 6 HALO INSTRUCTIONS -----[hi-par.zip](#)

HYGAIN

HYGAIN HH6BA 6MT HALO [hh6bahlo.zip](#)
HYGAIN 6ELE 6METER BEAM MANUAL [hygain.zip](#)

ICOM

IC502 MANUAL [ic502.pdf](#)
IC 505 ALC ADJUSTMENT (M0BCG) [p14.jpg](#)
IC706 EXTENDED TX 1.6-54MHZ (N1IST) [ics.zip](#)
IC502 BAND MOD (QST 12-81) [icf.zip](#)
IC 756 GX TX MOD (VK3ALM) [ic756.zip](#)
IC "500" SERIES MODIFICATIONS - 551, 551D, 502 AND VFO [icfh.zip](#)

GONSET



GONSET 6MT AMP MANUAL AND SCHEMATIC---[gonset6mt.zip](#)

JOHNSON

VIKING 6 AND 2 (COMPLETE MANUAL AND SCHEMATIC) --[vik62.zip](#)
ASSEMBLY INSTRUCTIONS FOR THE VIKING 6 AND 2 (PLEASE READ THE PAGES A-G FIRST) [62assembl.zip](#)

KENWOOD

TS 60 WIDE BAND RECEIVE MOD ----[ic60wbcm.zip](#)
TS 680 MODS (WB5HJV, WB5ITT) [tsse.zip](#)
EXTENDED COVERAGE KENWOOD 690 30-50MHZ [eks.zip](#)
KENWOOD TS690 MOD (QST 6-94) [tssni.zip](#)

KLM

KLM 50-7 LD ANTENNA--[klm507ld.zip](#)
KLM 50-52-11 ANTENNA--[klm50-52.zip](#)

KLM 6M-10 ANTENNA-----[klm6m10.zip](#)

KLM 6M-14 ANTENNA-----[klm6m14.zip](#)

KNIGHT

KNIGHT T-175 6/10 METER LINEAR AMP MANUAL [t175.zip](#)

6MT CONVERSION OF THE KNIGHT C-100 CB (QST 3-64) [f45.zip](#) © Lowell Enterprises

LAFAYETTE

MANUAL AND SCHEMATIC FOR THE LAFAYETTE HA-460 [460.pdf](#)

MANUAL AND SCHEMATIC FOR THE LAFAYETTE HA-650 [ha650.zip](#)

LINEAR SYSTEM INC.

SIDEBANDER SIX INSTRUCTION MANUAL [sb50.zip](#)

PARTS LIST [sb50a.zip](#)

SCHEMATICS [sb50b.zip](#)

MFJ

MFJ -9406 SQUELCH CONTROL [mfjsquelch.zip](#)

MFJ CW ADAPTER [mfjcw.zip](#)

SWAN

CONVERTING THE SWAN 120 TO 6MT (73 6-67) [f41.zip](#)

SWAN 250 MODS [swant.zip](#)

SWAN 250 MODS AND SERVICE BULLETIN [swan250mods.html](#)

TOKYO HIGH POWER

HL86V 50MHZ ALL MODE AMP SCHEMATIC [d5.zip](#)

WHIPPANY LABS

LIL-LULU TRANSMITTER [lillulu1.zip](#)

YAESU

CONVERTING THE FL2100B TO 6MT. SCHEMATIC ONLY [fl2100b.jpg](#)

ACCESSORIES

COMAIR ELECTRONICS - CF-6 TVI FILTER [conair.zip](#)

GAVIN MAVERICK AND MAVERICK II FILTER [maverick.zip](#)

CB TO 6MT (73 6-80) [f36.zip](#)

6 METER HELIAX DUPLEXERS [CAVITIES](#)

TVI FILTER (HORIZONS 4-63) [c10.zip](#)

A SOLID STATE SANDWICH FOR VHF 6 AND 2 (QST 10-69) [sss.zip](#)

FET ON 6MT (73 2-67) [fos.zip](#)

50 YRS ON 50MHZ (VK3OT) [50yrs.zip](#)

MICOR LOW BAND RADIO MOD (SENT IN BY KB4MDZ) [micor.zip](#)

PEARCE SIMPSON CONVERSION TO 6MT SSB (KD4NUE) [pearce.zip](#)

AUSTRALIA BEACON MAP [vkmap.zip](#)

NEW ZEALAND BEACON MAP [zmap.zip](#)

*CB TO SIX METRES BY SHAWN BARIS ZR1EV [zscb.zip](#)

A link to another 6 meter HELIAX DUPLEXER <http://www.qsl.net/kf6yb/duplexer.html>

AMPLIFIERS

UTILIZING THE 826 (AMP FOR 10, 6 AND 2) (QST 5-50) [826.zip](#)

A CATHRODE TETRODE DRIVEN AMP (QST 9-84) [smtea.zip](#)

811 AMP [d7.zip](#)

RAYTRACK 6MT AMP MODIFICATION (K5AM) [rayt.zip](#)

KILOWATT FOR 6 AND 2 USING 3 4CX-250R (QST 2-64) [kfst.zip](#)

SIX METER FINAL AMP- 75 WATTS OUT (73 1-67) [sfo.zip](#)

4-400 AMP (73 8-66) [fdf.zip](#)

A COMPACT BRICK FOR 6MT (QST 10-90) [smbr.zip](#)

100 WATTS ON 6MT [owat.zip](#)

A PAIR OF 6MJ6 AMP (WA5UUD) [uud.zip](#)

A CHEAP HALF GALLON (73 7-70) [chgl.zip](#)

4CX250B AMP (GM4FZH) [fzh.zip](#)

AMPLIFY YOUR 6MT FUN (73) [afun.zip](#)

SOLID STATE 6MT AMP (QST 5-82) [ssamt.zip](#)

6MT MINI-LIN (QST 4-82) [mnlm.zip](#)

ANTENNAS AND ACCESSORIES

VE3VRQ 6MT CUBICAL QUAD ANTENNA ----- [quad antenna](#)

W3RW 6 AND 10 METER LONG WIRE ----- [w3rw610.zip](#)

6 METER LOOP (K0FF) [K0FF](#)

6 METER DIPOLE BY KE6LDX [ldx.zip](#)

3 ELE DELTA LOOP (QST 9-69) [f47.zip](#)

PORTABLE 3 ELE (VHF 7-62) [f33.zip](#)

BIRD CAGE BEAM (VHF 7-62) [f32.zip](#)

A 2 BAND HALO FOR 6 AND 2 (QST) [1.zip](#)

A TRI YAGI FOR 50MHZ (QST 6-80) [stri.zip](#)

COPPER CACTUS ANTENNA (K6OZP) [ccjp.zip](#)

STACKED HALOS FOR 6 AND 2 (QST 8-64) [sh.zip](#)

QUAD FOR 6 AND 2 (QST 2-63) [qd.zip](#)

MOBILE ANTENNA (QST 5-66) [bil.zip](#)

6ELE ON 6MT (QST 10-57) [sesm.zip](#)

W7GJ "BIG" 50MHZ ANTENNA"

LONG WIRE ANTENNA (QST 2-97) [lwant.zip](#)

6MT LOOP ANTENNA (1-91) [smlop.zip](#)

8 ELE 6MT YAGI [eelsm.zip](#)

4 ELE 6MT BEAM [felb.zip](#)

MULTI - BAND ANTENNA 6 AND 10 [satnn.zip](#)

KLM 11 ELE ANT [klme.zip](#)

8 ELE 6MT --- 4, 7 AND 8 ELE 2MT ANTENNA (WB7PMP) [pmp.zip](#)

BOW TIE [btsm.zip](#)

CONVERTERS

6 METER CONVERTER (QST 6-82) [smrcv.zip](#)

6MT CONVERTER (QST 6-61) [f44.zip](#)

SIX METER CONVERTER (73 1-67) [smv.zip](#)

PREAMPS

6MT PREAMP (HORIZONS 4-63) [c9.zip](#)

TRANSISTOR PREAMP FOR 6MT AND 144 (QST 11-62) [tpsa.zip](#)

6MT PREAMP (KA7IXS) [kaixs.zip](#)

RECEIVERS

AN ULTRA SIMPLE RECEIVER (QST 12-97) [usr.zip](#)

TRANSMITTERS

A 6MT TRANSMITTER (VHF 12-62) [f28.zip](#)

500 WATT TRANSMITTER (QST 1-64) [wt.zip](#)

[BACK TO HOMEPAGE](#)

Copyright © 2001 by Lowell Enterprises

© Lowell Enterprises

© Lowell Enterprises

© Lowell Enterprises

Amateur Radio



Amateur Radio

- Antennas

 - [Super Linear Loaded Inverted V With Photos](#)

 - [Copper Cactus \(Multi-Band J-Pole\) With Drawings](#)

 - [Single Coax Feed \(for Copper Cactus\)](#)

 - [The Stacked-J \(Double High J-Pole\) With Sketch](#)

 - [Mirrored-J \(Triple Height, Side Mounted J-Pole\)](#)

 - [K-FACTOR Chart & Table \(Element Length Adjustment\)](#)

- Miscellaneous Data

 - [National 10-Codes](#)

 - [Just Plain NonSense](#)

 - [Who's Who](#)

 - [Electronic Hole Theory](#)

 - [Computer Terms](#)

Document Revision Date 8/12/99 Applicable To This Page Only

<% @ Language=JavaScript %>

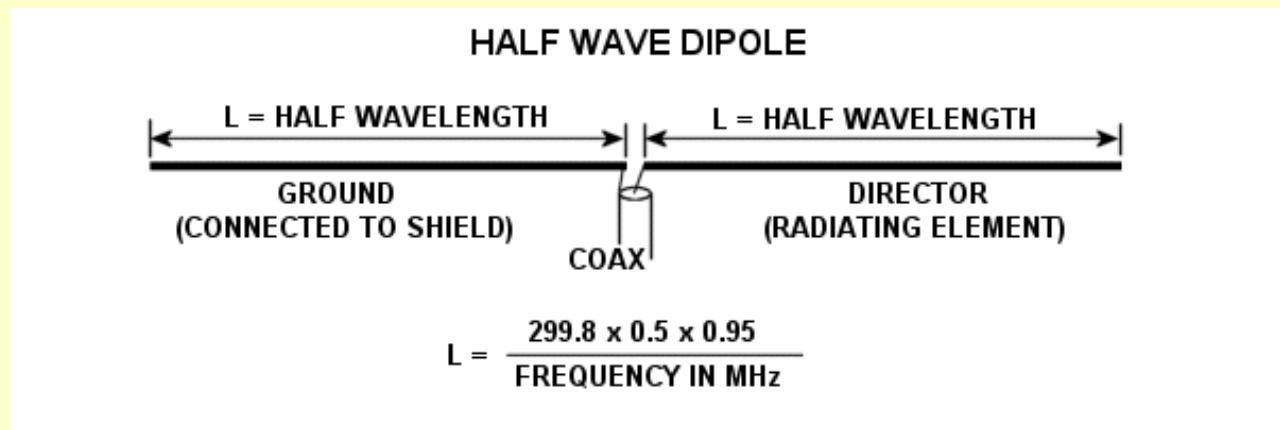
SIMPLE MADE DIPOLE FOR 6 METERS REVIEW BY JIM BAUDO

From: "Rune Austefjord" <rune.austefjord@hjemme.no>

To: "JIM BAUDO" <n0uqz@yahoo.com>

Subject: Re: Homemade 6m dipole

Date: Fri, 24 Jan 2003 17:40:22 +0100

My Quck Review Of My 6 Meter Dipole :

Made a simple dipole from 1.25mm diameter copper speaker wire.

Each of the two elements are $(299.8 \times 0.5 \times 0.95) / \text{frequency} = 142.5\text{cm}$ (for 51MHz).

These elements were soldered to the center and ground of a BNC female connector in this instance.

There were no baluns in use.

SWR was measured to approx. 1.1:1 max in the band 50MHz to 52MHz.

The antenna was hanged vertically in free air at least 2 feet away from any horizontal obstacles, and 4 feet above ground.

Transmitter power was varied from as low as 5W to as much as 100W, with little variation in the SWR.

Because there is little to none 6m activity in my area I didn't have the oppportunity to test against other stations.

Overall impression of the antenna is good, easy to make, easy to make play, mobile as it could be coiled up and put in a pocket for transport, cheap and simple. Check out the graphic.

Hope this is what you wanted. Have made a 2m GP-antenna from an old umbrella as well.

73 de LC3LCT

[ANTENNAS TRIPODS TOWERS ROTORS AND ACCESSORIES MAIN MENU](#)

MOST ALL PHOTOS WITH HP CAMERA, BY JIM BAUDO. EMAIL YOUR COMMENTS, OR YOUR REVIEW TO JIMBAUDO@YAHOO.COM HAM RADIO CALL N0UQZ

THE 6 METER OMNI HALO

from
KB1DIG

April 28th, 2002, By Steve KB1DIG

Something a little more advanced. Always fun to try out new bands. This halo is made with a true Gamma Section this time and is fashioned from aluminum. Most of the parts are leftovers from old car projects. The 3/8" fuel line I used came from Summit Racing Equipment: #SUM-G2538, and a 25' section costs only about \$20.00.

Some of the mods I came up with were:

Welded the elements to the aluminum plate with some of that "Alumalloy" stuff advertised on television. I drilled a small hole in one of the elements to allow condensation to evaporate.

Capped off the end of the gamma arm with a plug to keep the weather out.

The plug was an automotive type used to block off a PCV line from a carburetor.

After mounting horizontally to a 10' mast I added a support system made from 2 thin 3' fiberglass rods and some wire-ties.

Also remember to hot-glue the wire-ties to the fiberglass rod and adjust for lowest swr as usual.

Works slick! CQ CQ DX!!!

HAM UNIVERSE



50 to 51Mhz Halo
with a SWR of
about 1:3 to 1

Steve ;-)
KB1DIG

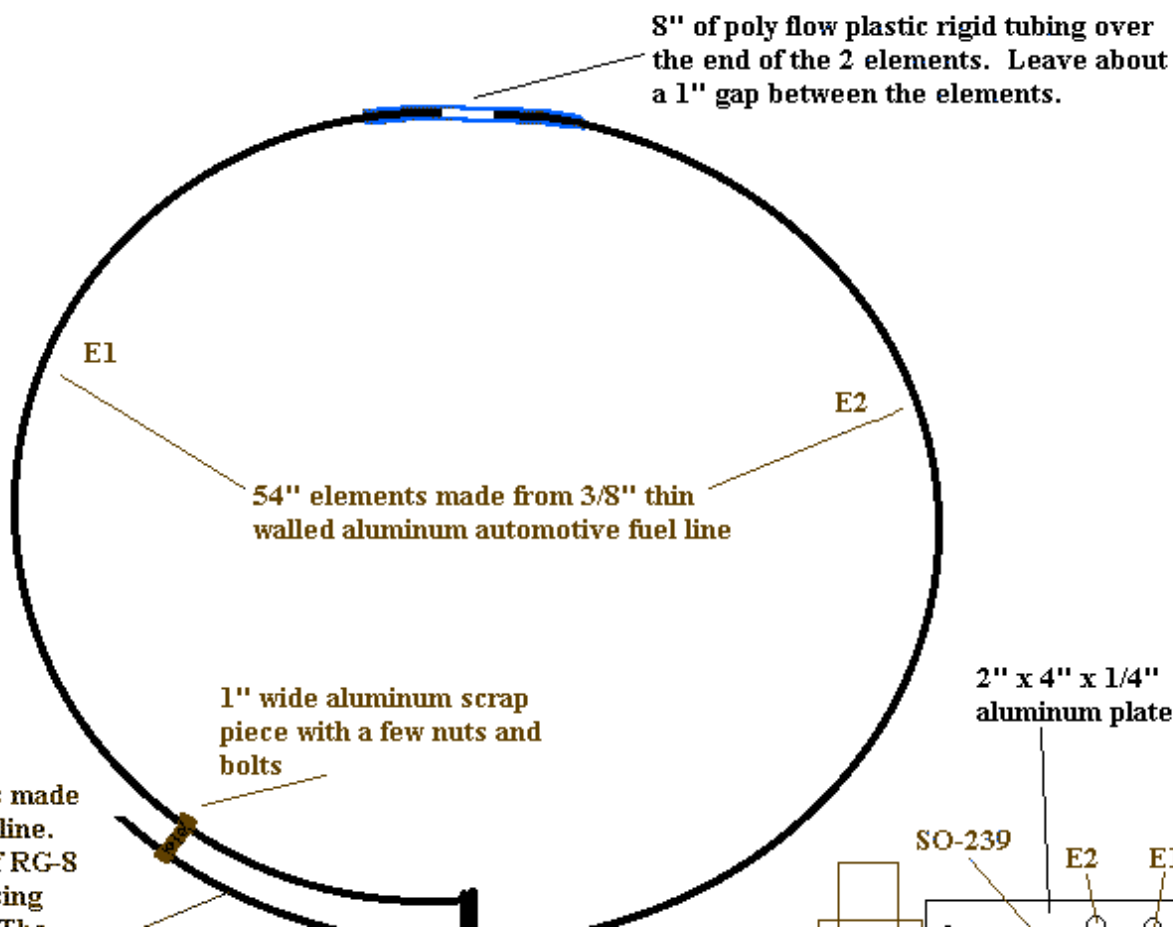

Gamma arm is 14" and is made from the same 3/8" fuel line. Inside is a 14" section of RG-8 coax with the outside casing

THE KB1DIG 6 METER OMNI HALO LOOP

coax with the outside casing and shielding removed. The gap between the Gamma and E1 is about 1 1/2" or less.

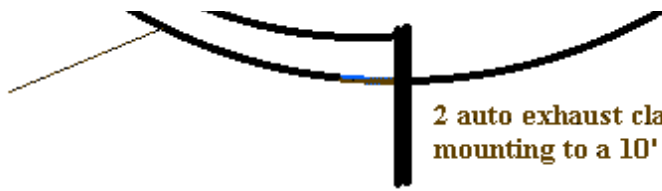

2 auto exhaust clamps for mounting to a 10' mast

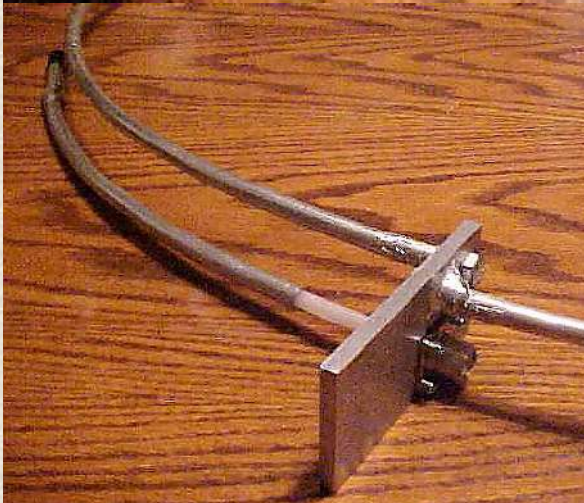
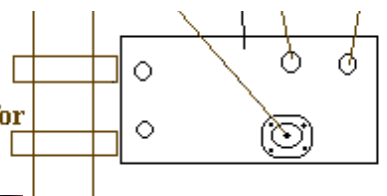

See closeup #1
below

See closeup #2 below

<<See closeup #3
below>>

Closeup #1

Closeup #2

<<<SO 239

Closeup # 3

The Finished Halo ready to serve!
Pass the rig and a little salt and pepper please!
Anybody want fries!...**KB1DIG Have Fun!**

<<Notice 1" gap

<<Shorting strap

RG-8>>>

Many thanks to Steve, KB1DIG for allowing us to share his
project with you.

Check out Steves site and get questions answered at the link
below

["KB1DIG HAM SITE"](#)

Congratulations to Kim, Steve's XYL, KB1GTR, ON HER
TICKET!

GOOD LUCK AND 73

N4UJW

[BACK TO ANTENNA DESIGN LAB!](#)

GRAPHIC INTENSIVE!
PLEASE ALLOW TIME TO LOAD!



Satellite TV the way I want it!
No Equipment to buy!

[Antennas & More for HF antennas](#)

K0FF's 6-meter SLOOP

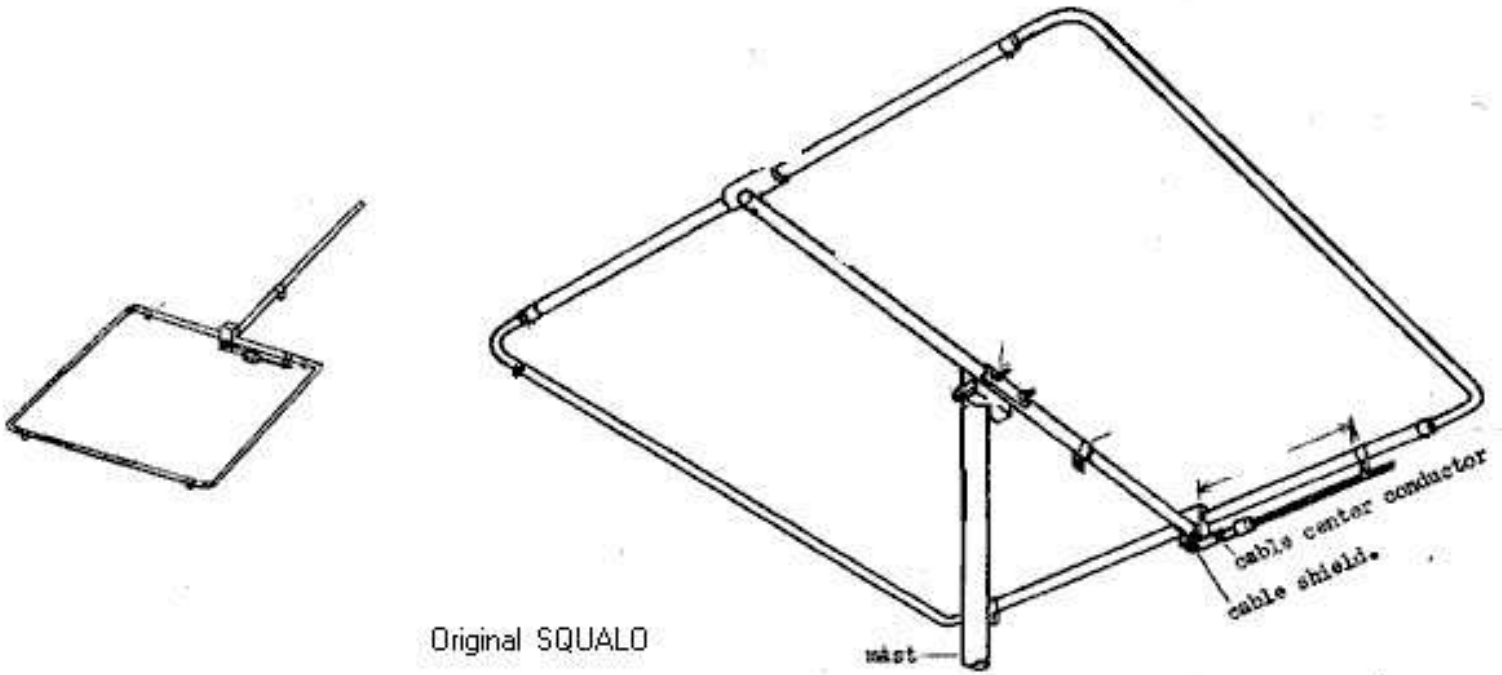

Electrical Equivalent Circuit
of K0FF Copper Square for 6

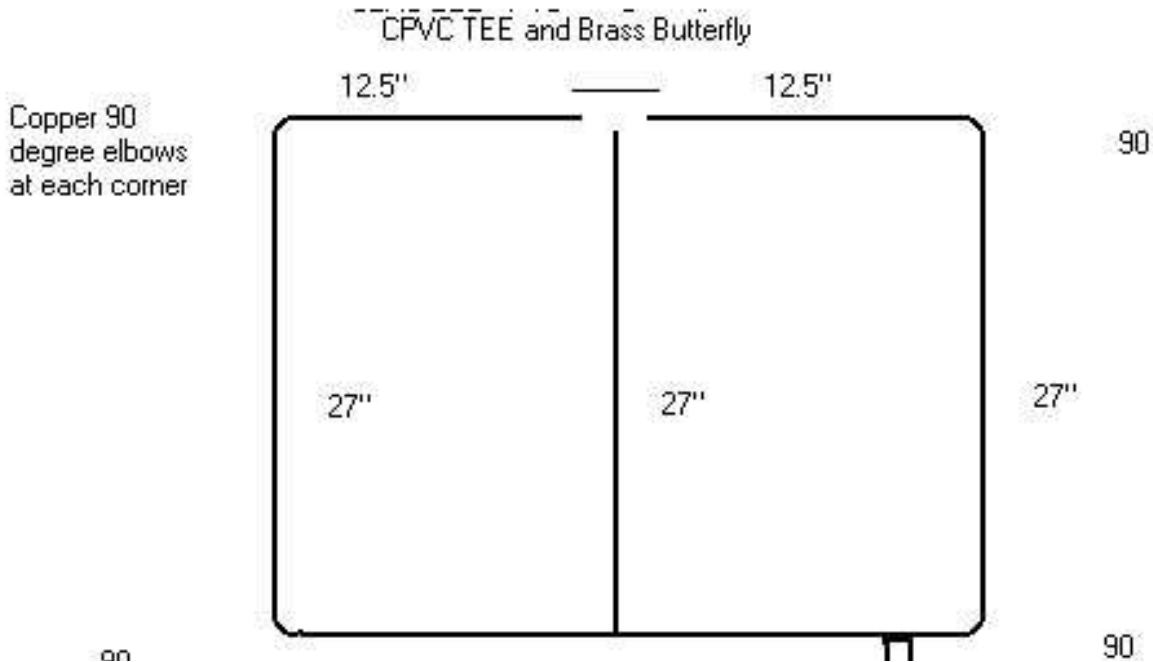

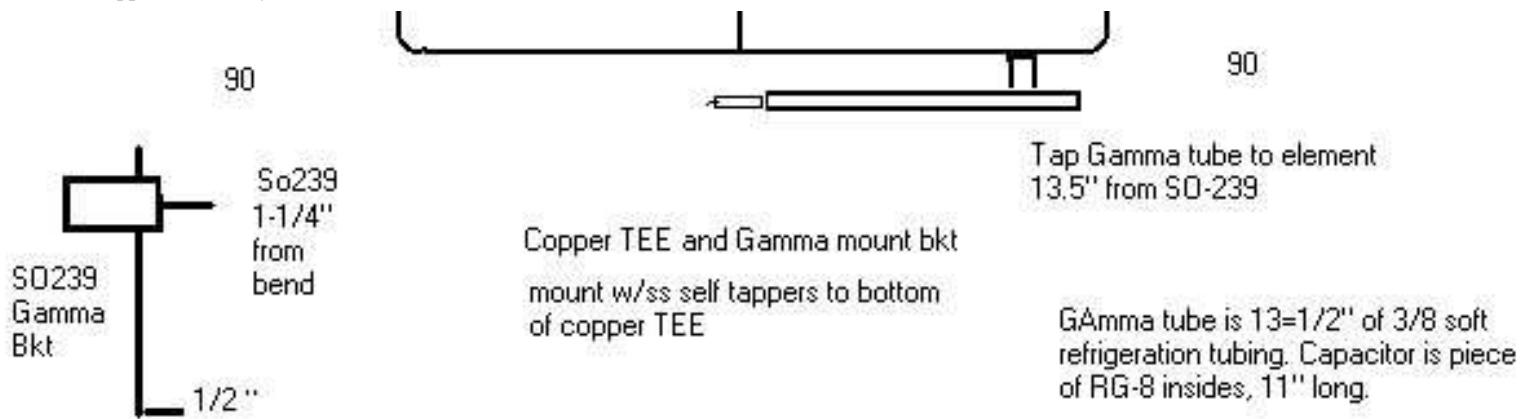

Characteristics:

It is more or less omni-directional, and horizontally polarized. Copper is the best possible electrical conductor at normal temperatures, next to silver. Copper conducts better than gold! Antenna efficiency is the RADIATION RESISTANCE of the antenna, divided by the ELECTRICAL RESISTANCE. An antenna made from copper is 1.6 times more efficient than the same antenna made of aluminum.

It presents a high angle of takeoff when mounted low, and singly (great for Es), can handle 100W. Stack two or more for extra gain if needed.

It's just a dipole folded around on itself, and supported at the far (open) end with a plastic insulator. "Bent Dipole" might be a good term, as a "Folded Dipole" is quite another thing.

The Gamma Match:

A low VSWR may be obtained by adjusting the Gamma Match shorting bracket position, and also the length of the tubing and shorting bracket. The Gamma bracket "finds" the 50 Ohm point along the element, and connects that to the Coax connector via the Gamma tube. The additional length of tube adds inductance into the circuit, and this is canceled out by the series capacitance formed between the insulated Gamma wire and the inside of the Gamma tube.

Description:

The shape is a closed 28" square, with a mounting /support bar through the middle. This mounting bar is attached to a copper TEE at the drive end, and to a CPVC TEE at the other end. The CPVC TEE acts as support and end-insulator for the radiating element and provides a mounting point for the Butterfly.

A large (3/4") part is used, and adapted down to fit the water pipe, to increase its insulating qualities, as there is very high voltage at this point. A strip of brass or copper 1/2 by 3" is screwed

to the outside middle portion of the CPVC Tee, through a small center hole, and is rotated one way or the other as a resonance tuner (Butterfly). When the Butterfly is at right angles to the element, the frequency is the highest, when parallel, it's the lowest.

A Gamma match sets the impedance to 50 Ohms, and the Butterfly adjusts the center frequency. Center frequency is 50.00 to 50.800 with the exact dimensions shown. Typically the 2:1 SWR bandwidth exceeds 500 kHz.

Mounting:

A U bolt and saddle through the central tube provides a center mounting point. Another approach is to install a copper TEE in the center tube, with the open end down. In that open end solder a 1/2" brass rod which has been drilled and tapped for 3/8-24.

Side mounting on a tower can be achieved by using conduit clips to fix it to a horizontal mast.

In some climates where water is a problem, drill small weep holes in the bottom corners. A spray coat of Krylon Clear Enamel will keep the copper shiny. If used mobile, you may use a colored paint, the same shade as your vehicle.

Construction:

Material:

1/2" Copper waterpipe :

- 3 ea. 27 inch piece
- 4 ea. 12.5 inch piece
- 4 ea. Copper 90 Degree elbow
- 1 ea. Copper TEE

Other Copper or Brass :

- 1 ea. 13.5 inch piece 3/8 i.d. Copper refrigeration tubing (Gamma tube)
*
- 1 ea. Brass plate 1/2" x 3" (Butterfly) *
- 1 ea. Brass plate: 1"x 2-1/4 in (to mount SO-239, Gamma rod) *
- 1 ea. Copper strip 3/8 x 4" to make Gamma tube bracket *

PVC :

- 1 ea. 3/4 CPVC TEE

3 ea. 3/4 to 1/2 CPVC reducer

Odds and Ends :

1 ea. 11" piece of RG8 insides (center conductor and insulation, Discard shield and outer plastic) *

1 ea. SO-239 coax connector (with tapped mounting holes and center pin) *

1 Lot Stainless Steel and Brass screws and Hardware *

Glue two of the 12.5" pipe sections into the CPVC reducers first, then glue the reducers into the opposite sides of the CPVC TEE. Lay the assembly on a flat surface with the center opening of the TEE facing the middle of the antenna. This is where the first 27" piece (mounting bar) goes in, via a reducer. On the outside edge of the CPVC TEE is where the butterfly attaches. For mobile or portable use, use 3 s.s. #6 screws through each of the CPVC TEE joints for added strength. The rest of the antenna solders together to form a square, using the 90 degree elbows at the corners. Drill small weep holes in the bottom corners of all four 90s to let accumulated water drain out.

The brass plate is bent to form an "L" 1-3/4" tall with a 1/2" lip. A 5/8" hole is provided 1-1/4 inch from the bend, and an SO-239 is attached . Two small holes are drilled in the lip and the plate is mounted to the copper TEE with s.s. #6 self taping screws. Attatch the center conductor of a 11" piece of RG8 insides to the center pin (center wire and plastic dielectric only- remove and discard shield and outer covering). This is accomplished by soldering or using a screw if the SO-239 has a threaded center pin *. Slip the other end of the RG8 insides into the 3/8" copper tube 10.5", and tap the copper tube to the radiating element 13-1/2" from the SO-239 center, with the Gamma tube bracket.

The tap on the Gamma sets the impedance presented to the feedline. Resonance (center frequency) is adjusted by turning the butterfly.

Mount 15 feet or more high, for home use, and wherever you can for mobile. An antenna like this can be mounted 3" to 6" above the roof of a vehicle using CPVC , PVC or acrylic spacers with suction cups.

Have fun on 6. Geo>K0FF

***Parts available in a kit from author, includes all "*" parts, drilled, punched, bent, and threaded, contact: K0FF@ARRL.NET**

Don't Eat the Batteries" clause:

Recently my wife and I bought a new TV set, and in the instructions for the hand held remote control the warning said "Don't Eat the Batteries".

SO....

WARNING!!! This antenna is an electrical conductor. Contact with power lines can result in death or serious injury. Do not install this antenna, supporting mast or tower structure near any power lines, or where they could come into contact with power lines should the antenna or structure fall.

Geo

Return to [Home Page](#).

A Long-wire Aerial for Six Metres

Brian D. Williams, GW0GHF

Issue, 56 February 1998

Having had the time to evaluate it, I find this aerial very useful for both semi-local and sporadic-E on six metres.

The antenna is about 65 feet of ordinary aerial wire, insulated at the far end. The near end connects to a matching unit situated in the loft of the house. The aerial wire enters the loft under a tile near the ridge of the roof of the house, through an insulating sleeve.

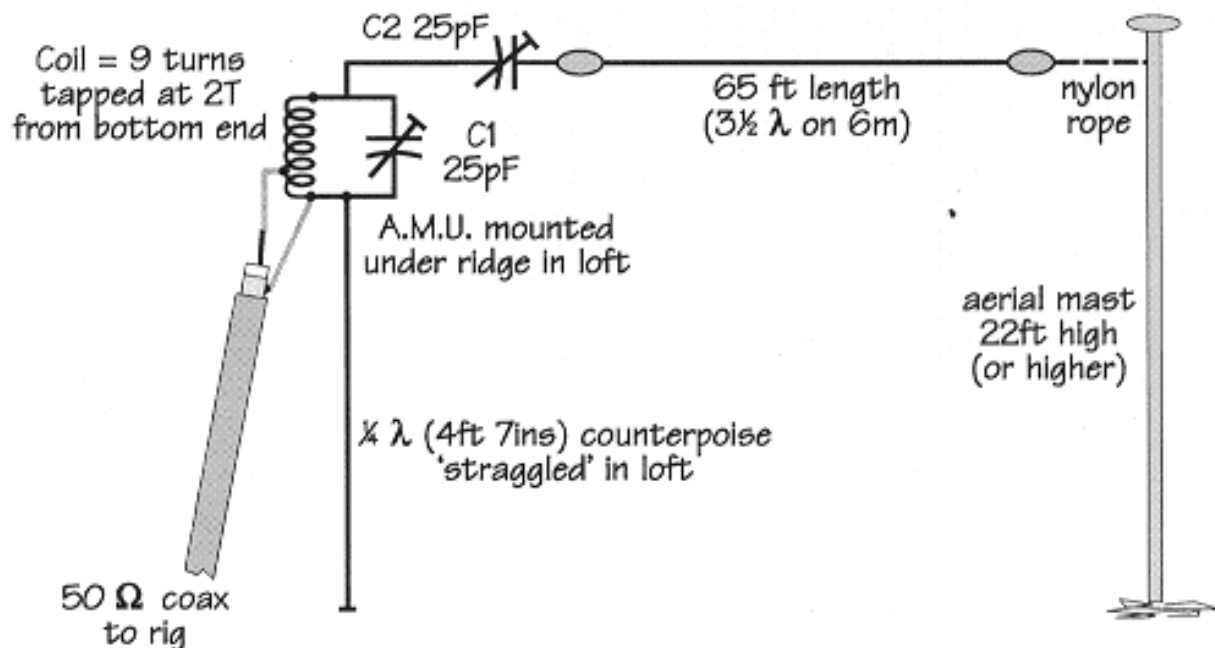

theoretical diagram.

The aerial is voltage-fed (high impedance) and the antenna matching unit (AMU) transforms this to match 50 ohm cable. The two trimmers are 'polycon' variables - these are OK up to 50 watts. For operation at higher powers, obviously more substantial trimmers, such as mica compression types, will be needed. Old radio receivers of the 1950 vintage or before are often a source of these types of trimmer. 'Cirkit' can supply them, but they are not cheap! The trimmers are likely to be the only 'expensive' parts required for this antenna, however.

The method of adjustment is to set C2 to half capacity and then adjust C1 for best noise on receive. Then feed in a carrier (or an audio tone on SSB) and adjust C1 for a low SWR reading. 1:1 is achievable at this QTH.

No problems with 'RF in the shack' have been encountered at 50 watts SSB. The counterpoise were effectively 'earths' the bottom end of the parallel-tuned circuit; it hangs from the AMU in the loft. It is 4ft 6in in length.

The AMU is constructed on a tobacco-tin lid. The coil is nine turns of 18 SWG copper wire taken from old coax cable. It is 3/8 inch in diameter, spaced over approximately 3/4 inch.

Increasing C2 too much will prevent the tuned circuit from resonating at 50MHz. This, in turn, depends on the capacitance of the whole aerial wire to earth - but no problems were found and it was easy to get unity SWR. Shorting out C2 might be acceptable if a low-capacity system can be constructed, but this did not work at my QTH.

The wire gives a gain of 4 dB in four directions at 35 degrees to the run of the wire. There are also several smaller lobes which are useful. This is a good 'listening' antenna with gain that can be arranged in desired directions.



[To return to the archive page click here](#)

An Indoor Loop Antenna for 6m

Colen Harlow, G8BTK

Issue, 56 February 1998

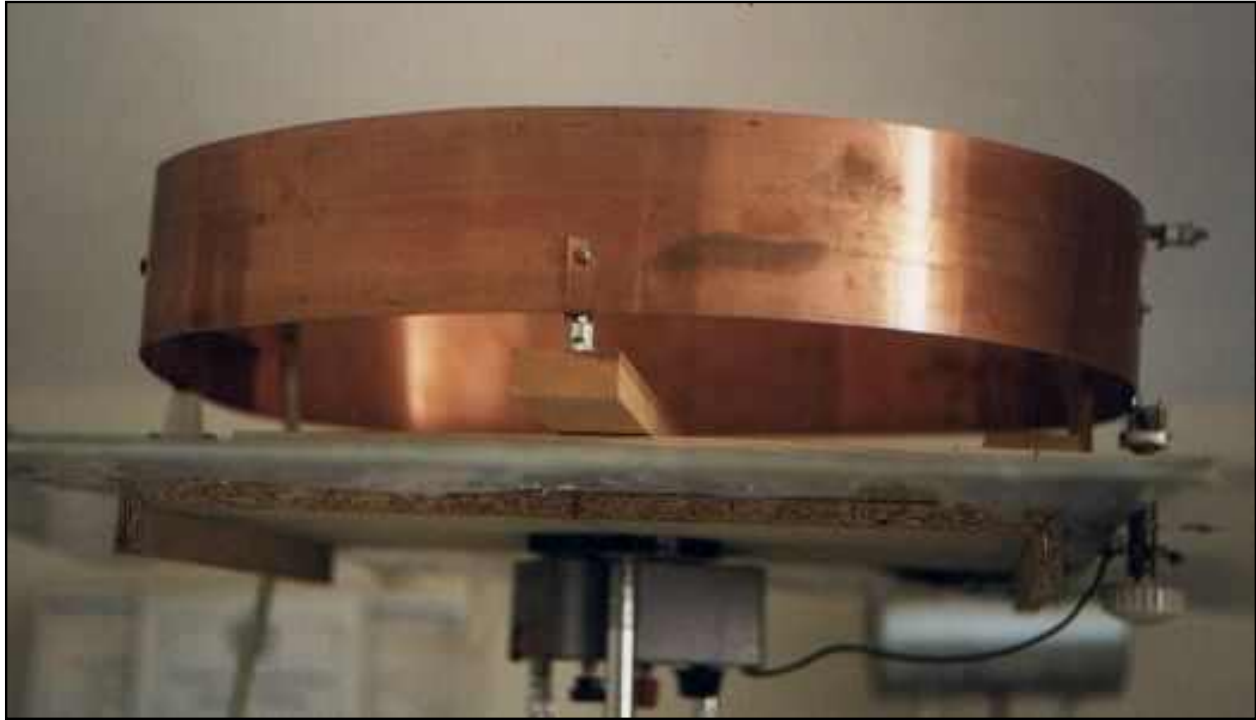

The 6m 20" high Loop.

I have worked 24 countries with my 20 inch loop. Living as I do in a flat with a complete ban on external antennas, I turned to the loop, having for many years experimented with this type of aerial in various forms. I now use them for six metres (20" diameter), four metres (10" diameter), two metres (6" diameter) and 70 centimetres (3" diameter).

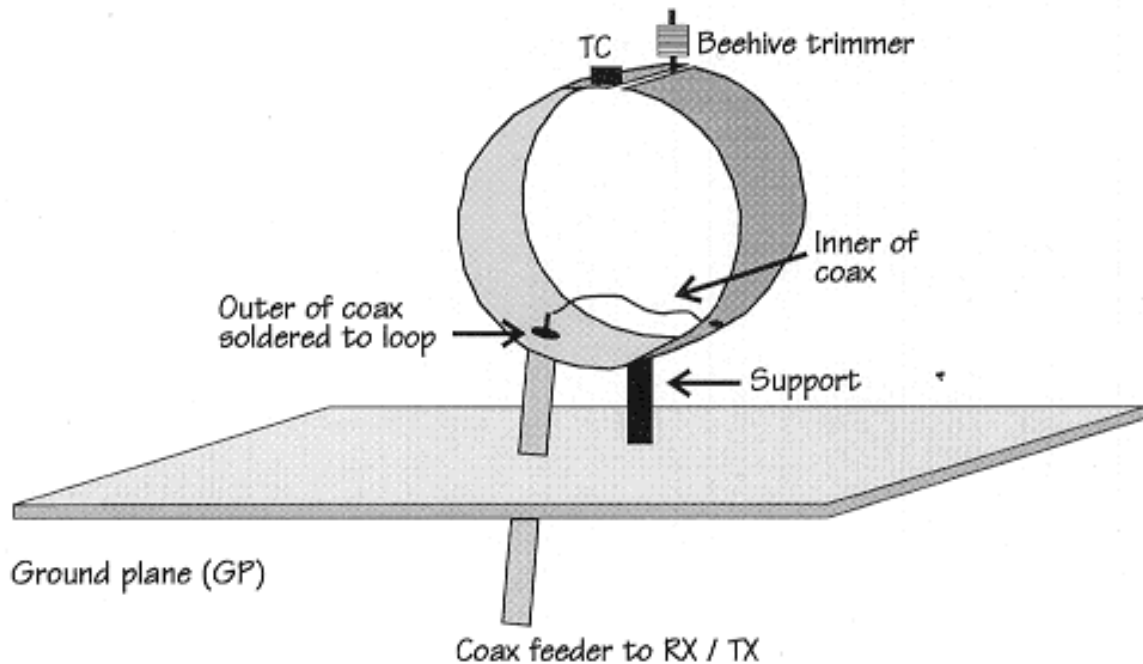

vertically polarised loop

The six metre loop (figures 2 and 3) consists of a four inch wide strip of copper formed into a ring, the ends of which are joined by a butterfly trimmer and beehive trimmer in parallel, for ease of adjustment of resonance. The loop is mounted above a ground plane of a three foot square aluminium sheet - hardboard covered with kitchen foil would do just as well. The loop is centrally positioned, about four inches from the ground plane.

The feed-point is taken at right angles from the opposite side to the capacitors. Good quality (ceramic, PTFE or similar) insulators should be used. The feeder coupling consists of a strip of copper or heavy-gauge wire as shown in the diagram.

The

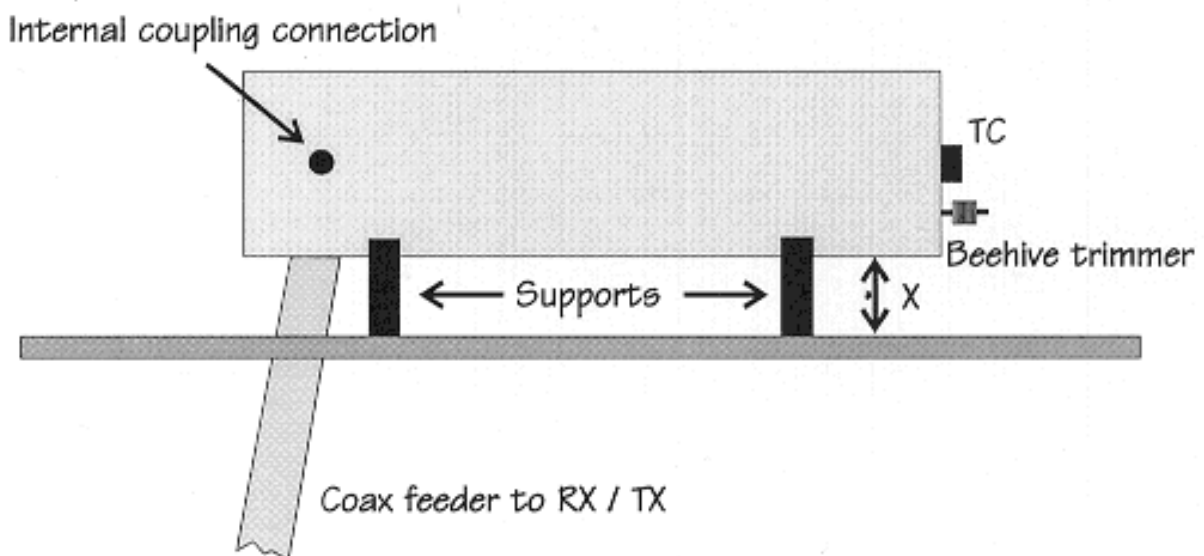

horizontally polarised version of G8BTK's loop

The separation of the loop from the ground plane ('x' in the diagram of the horizontally polarised version) determines, to a great extent, the radiation angle, as does the size of the ground plane. With a three foot ground plane I have found between four and 12 inches to be the best.



6m Loop Coupling and feed

For six metres a resonated loop also works very well and the vertically polarised version exhibits a very pronounced null.



[To return to the archive page click here](#)

The ZR6YY Antenna for 6m

Maurius, ZR6YY

Issue, 56 February 1998

The

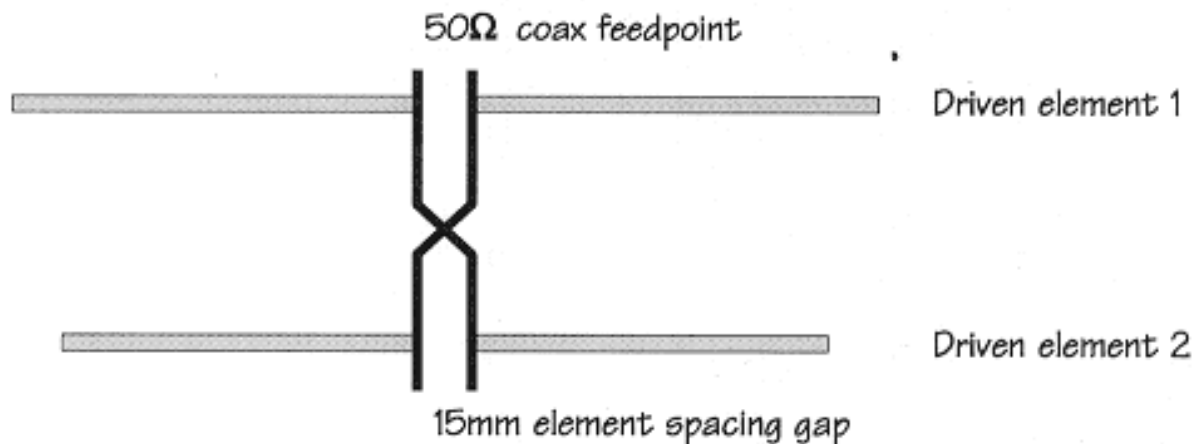

Driven elements of the ZR6YY antenna

Having received numerous requests to publish the design for the ZR6YY yagi I have now put the information out world wide in the hope that the design works for you.

| Element Lengths | |
|-----------------|----------|
| reflector | 320 cm |
| driven 1 | 296.5 cm |
| driven 2 | 274.5 cm |
| director 1 | 255 cm |
| director 2 | 254 cm |
| director 3 | 245 cm |

| Element Spacing | |
|---|----------|
| The measurements are taken from the reflector element | |
| reflector | 0 |
| driven 1 | 78.5 cm |
| driven 2 | 120.8 cm |
| director 1 | 179.2 cm |

| | |
|------------|--------|
| director 2 | 267 cm |
| director 3 | 383 cm |

Construction

All the elements are isolated from the boom. The two driven elements are fed direct and 180 degrees out of phase. Feed the antenna directly with 50 ohm coax no balun necessary. Driven element 1 and driven element 2 are made up of two pieces of aluminium each separated by a 15mm gap.

Technical note from Clive, G4FVP

The design shown has considerable experimental potential and should give a good forward gain on a short boom length of only 3.83 metres. The concept of the yagi is the two driven elements which act as an end-fire array. This should theoretically give a gain of 3dB but will in practice be less. Remember to reverse the feedline between the two driven elements to ensure they are 180 degrees out of phase.

Maurius does not specify the feeder between the two driven elements however a starting point would be to use an electrical half wave length of 300 ohm slotted ribbon feeder. To determine the electrical half wave multiply the free space length by the velocity factor of the cable in use. For 300 ohm slotted ribbon feeder this will be $150/f \times 0.87$. For 50.100MHz this is 2.60 metres.



[To return to the archive page click here](#)

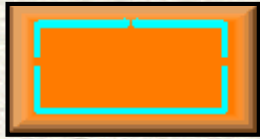

Moxon Rectangles for 6 Meters



L. B. Cebik, W4RNL

I have had numerous requests over the last few years for the dimensions and construction plans for Moxon rectangles designed for the 6-meter band. The Moxon rectangle is a quite broad-band antenna, but it is not quite broad enough to cover the entire band. As well, the lower end of the band is the major arena for horizontal polarization using CW or SSB. The upper portion of the band sees most of the FM activity, with vertical polarization being standard.

Hence, for full band coverage--or for selected use of one or the other mode of activity--we really need 2 Moxons. The first will be a horizontally oriented beam designed for 50.5 MHz with coverage of the first MHz of the band. The second will be a vertically oriented version designed for 53 MHz, with coverage from 52 to 54 MHz. After looking at the characteristics of these two versions of the same basic design, we shall make a few construction suggestions. Finally, we shall show how to combine them into a single array--but with separate feedlines.

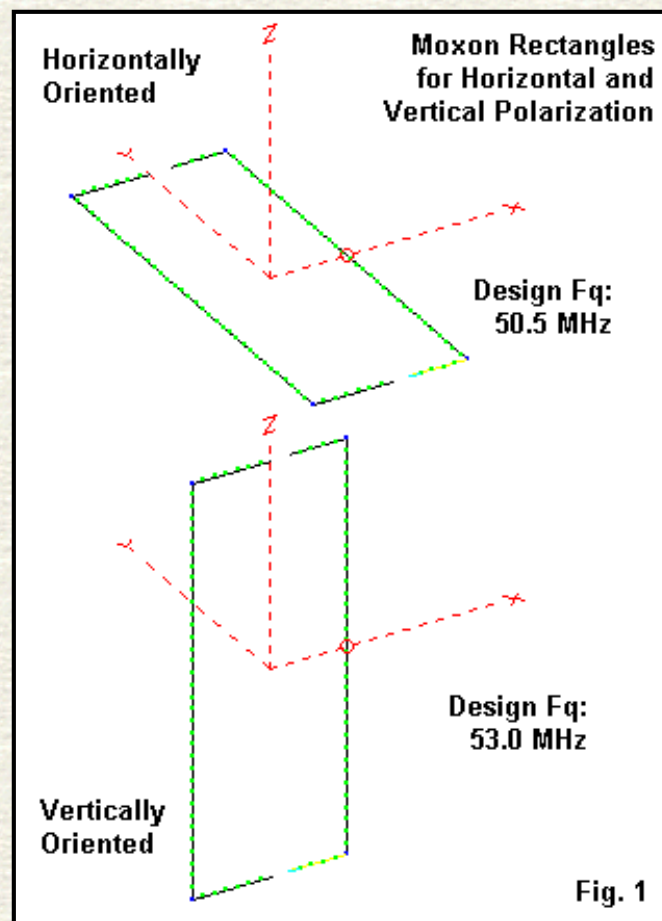
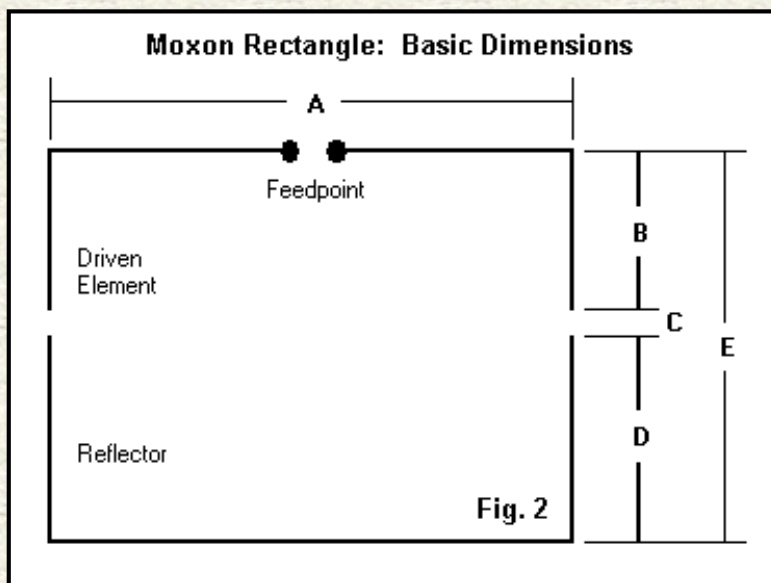

Fig. 1 shows the general outlines of the two types of Moxons. The Moxon is a driver-reflector type of parasitic array. Unlike standard Yagi designs that employ only the coupling between parallel lengths of element conductor, the Moxon folds back its elements to provide a second form of coupling. The coupling of the driver and reflector tails that face each other provides a second form of coupling, and the combination of the two gives us an array that we can design for very good front-to-back performance, about as much forward gain as a 2-element Yagi, and a 50-Ohm feedpoint impedance for direct connection of

a standard coaxial cable feedline.



Since we need a way to refer to the parts of a Moxon when giving dimensions, **Fig. 2** supplies what has become a set of default designations. Dimension A is the total side-to-side dimension of the array. B is the driver tail or fold-back portion, and D is the reflector fold-forward portion or tail. C is the most critical dimension, the gap, and tends to vary as a direct function of the element diameter. E is simply the sum of B, C, and D, and gives us the total front-to-back dimension of the array.

All 6-meter Moxons will be about 7' wide or about 3.5' each side of the center line. The front-to-back dimension will be about 2.5', plus or minus a little. Hence, the Moxon makes a very compact array, suitable for enhancing repeater communications or for SSB operation in local nets.

In fact, the precise dimensions for a 50-Ohm Moxon for any frequency and element diameter have been developed into several computer programs, ranging from a GW Basic utility in the HAMCALC suite to a NEC-Win Plus model to a stand-alone Windows program developed by AC6LA and available for free download from his site (<http://www.qsl.net/ac6la>). Since all of them are based on the same modeling and regression analysis that I performed some time back, all will give the same dimensions for the same design frequency and element diameter.

Let's start our foray into 6-meter Moxons with the low-end horizontal version.

A Horizontal Moxon Rectangle for 50.5 MHz.

The materials that folks have access to will vary from region to region. Therefore, let's make a chart of dimensions. All of the dimensions will presume that we are using some form of aluminum tubing, ranging from 1.0" down to 0.25" in diameter. As we shall see in the construction section, aluminum tubing is an optimal choice for a 6-meter Moxon.

In the following table, all dimensions refer to **Fig. 2** and are in inches.

.....

Dimensions for a 50.5-MHz Moxon Rectangle

| El. Dia. | A | B | C | D | E |
|----------|-------|-------|------|-------|-------|
| 1.0 | 83.61 | 10.40 | 4.58 | 16.22 | 31.20 |
| 0.875 | 83.68 | 10.53 | 4.46 | 16.21 | 31.20 |
| 0.75 | 83.76 | 10.69 | 4.32 | 16.19 | 31.20 |
| 0.625 | 83.86 | 10.86 | 4.16 | 16.18 | 31.20 |

| | | | | | |
|-------|-------|-------|------|-------|-------|
| 0.5 | 83.97 | 11.07 | 3.97 | 16.15 | 31.19 |
| 0.375 | 84.12 | 11.32 | 3.74 | 16.12 | 31.19 |
| 0.25 | 84.31 | 11.65 | 3.44 | 16.08 | 31.18 |

.....

Note that the dimensions change only a small amount from one tube diameter to the next. Moreover, the front-to-back dimension (E) changes almost not at all. However, the differences are important to centering the performance curve of the Moxon on the design frequency, which then has consequences for performance at the band edges. So using the dimensions that apply to the element diameter that you will use does have significance.

Let's set the antenna 25' above ground, which is just over 1.34 wavelengths up. The forward gain will be about 11.4 dBi at 50.5 MHz, with a 180-degree front-to-back ratio of about 30 dB and a 78-degree beamwidth between -3-dB points. The feedpoint impedance of 50 Ohms, plus or minus 1 to 2 Ohms reactance.

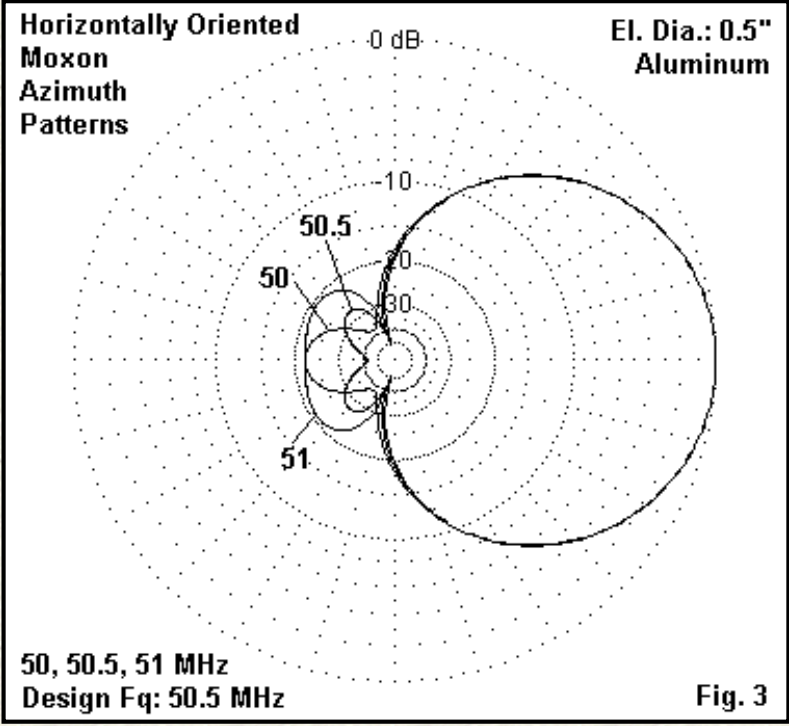
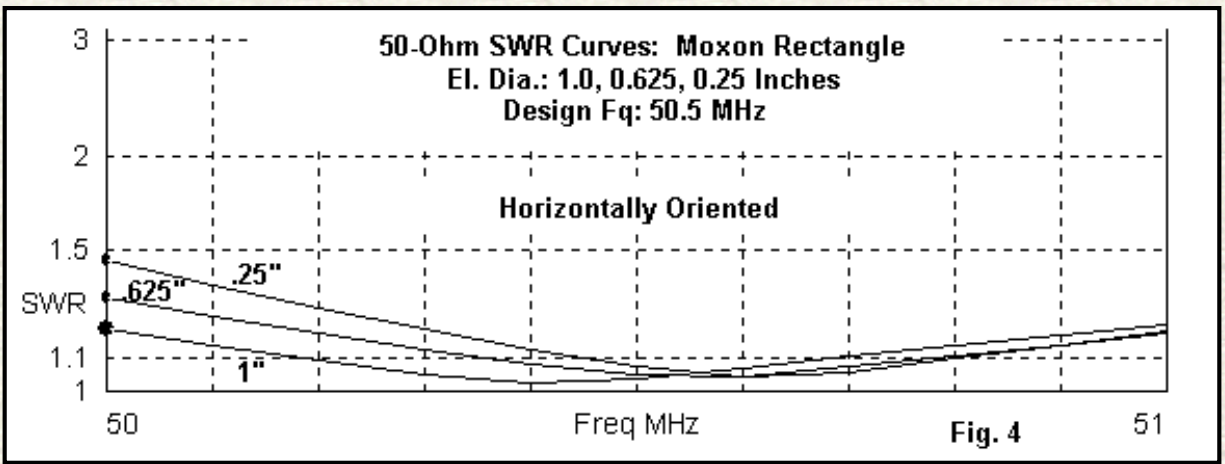

Fig. 3 overlays the design frequency and the passband edge azimuth patterns of the Moxon rectangle when oriented horizontally. As you can see from the patterns, taken for a version using a 0.5" diameter element set, as we move lower in frequency, the gain increases very slightly (too slightly to ever be measured in operation), and the rearward radiation begins to increase. Above the design frequency, the gain decreases by an equally slight amount, and, again, the rearward radiation pattern shows growth.

The performance of the antenna is virtually unchanged at the design frequency for any tubing size. However, the band-edge performance does change (in this case, using a 1-MHz passband). The fatter the tubing, the slower the rate of forward gain change. More significantly, the fatter the tubing, the slower the growth of rearward radiation lobes both above and below the design frequency. However, those changes are not so great as to override considerations such as the most convenient tubing size for constructing a Moxon rectangle.



Tubing size also makes a difference in the 50-Ohm SWR for the final antenna, as measured at the antenna terminals, as shown in **Fig. 4**. For a 1-MHz passband, almost any size tubing will do, and the SWR at the shack end of the coax is likely to be too low to get a definite frequency for the lowest value.

A Vertical Moxon Rectangle for 53.0 MHz.

The design principles do not change at all when we flip the Moxon rectangle for upper 6-meter service. However, the dimensions will change, since we are now using a design frequency of 53.0 MHz in order to cover the 52-54-MHz range. The following table provides dimensions, again in inches and again using **Fig. 2** as a reference.

.....

Dimensions for a 53.0-MHz Moxon Rectangle

| El. Dia. | A | B | C | D | E |
|----------|-------|-------|------|-------|-------|
| 1.0 | 79.64 | 9.86 | 4.41 | 15.46 | 29.73 |
| 0.875 | 79.71 | 9.99 | 4.29 | 15.45 | 29.73 |
| 0.75 | 79.79 | 10.14 | 4.16 | 15.44 | 29.73 |
| 0.625 | 79.88 | 10.31 | 4.00 | 15.42 | 29.73 |
| 0.5 | 79.99 | 10.50 | 3.82 | 15.40 | 29.72 |
| 0.375 | 80.13 | 10.75 | 3.60 | 15.37 | 29.72 |
| 0.25 | 80.31 | 11.07 | 3.31 | 15.33 | 29.71 |

.....

The last decimal place in column E, the overall front-to-back dimension, may be a digit or two off the sum of B, C, and D due to rounding of the individual values. However, I doubt that any builder will be constructing the elements to a hundredth of an inch tolerances. In fact, in the construction section, we shall be slightly altering the dimensions to take account of the fact that we shall bend the tubing at the corners.

Once more, let's place a 0.5" diameter version of the antenna at a height of 25' above ground. At the design frequency, we shall obtain a 50-Ohm feedpoint impedance accompanied by a front-to-back ratio well above 30 dB. (Vertical orientation affects the front-to-back ratio less than horizontal orientation for an antenna within about 2 wavelengths of ground.) However, unlike the horizontal version of the array, the peak gain is only about 7.6 dBi. Let's see why.

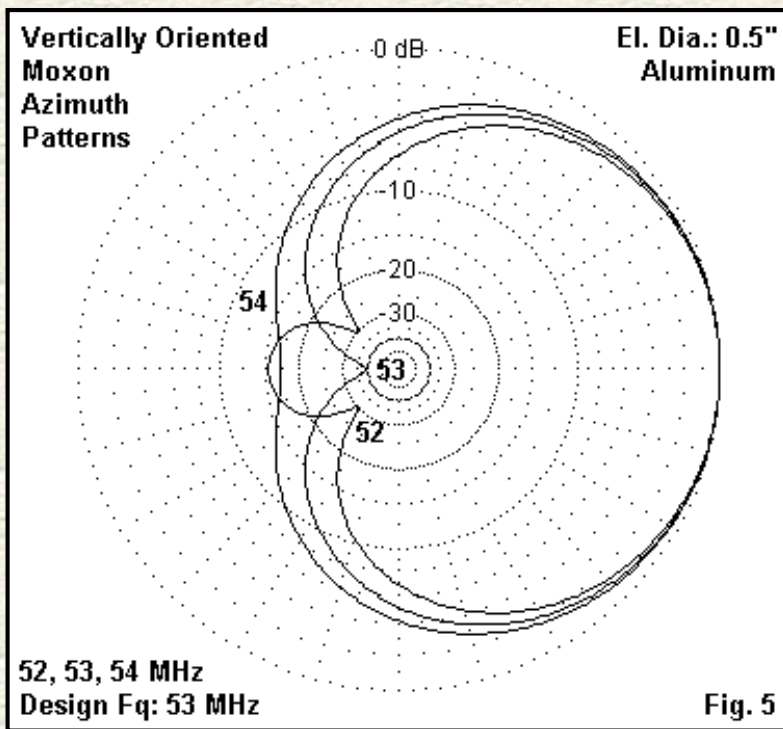
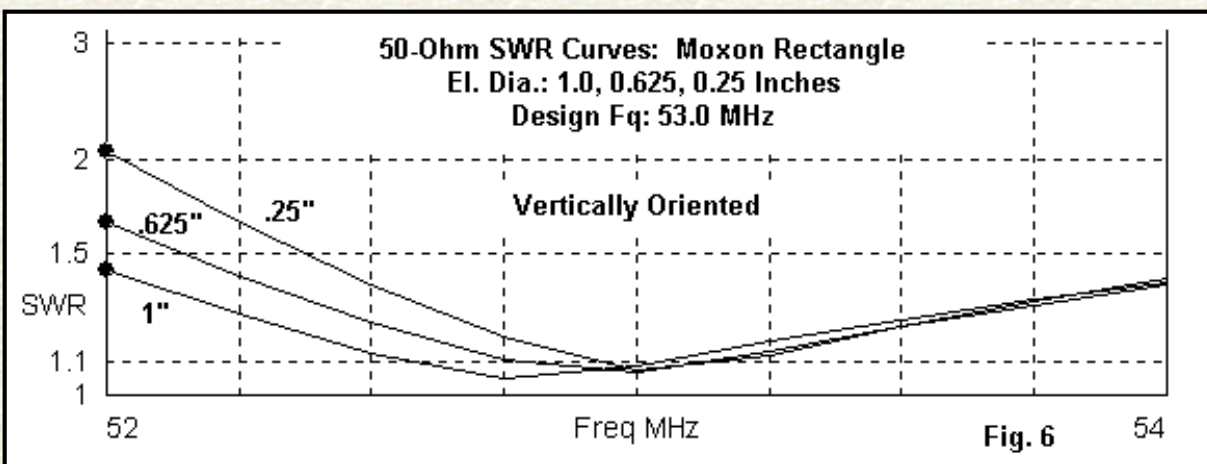

Fig. 5 overlays the azimuth patterns of the antenna at the design frequency and at 52 and 54 MHz. In all cases, we see a very wide beamwidth, over 142 degrees between -3-dB points. That increased beamwidth--about twice the value for the horizontal version--spreads the radiated power over a much wider area and thus reduces the peak gain. This is inherent in any parasitic array with all of the elements in a single plane. Nevertheless, both the horizontal and the vertical versions of the array have almost 4 dB gain over their counterpart dipoles at the same height.

As the patterns show, the increased bandwidth that we require of a vertical Moxon increases the rearward radiation at the band edges. Once more, the fatter the elements, the less growth to the rearward radiation for any change in frequency relative to the design frequency.



In Fig. 6, we have the 50-Ohm SWR curves for the array at selected element diameters. The SWR increases more rapidly below the design frequency than above it. The antenna feedpoint impedance for the thinnest tubing actually is above 2:1, although at the shack end of the coax, where we usually measure SWR, it may seem lower than that value. Hence, one might well think in terms of at least an intermediate tubing size for the vertical Moxon.

The SWR climbs more slowly above the design frequency, suggesting that we might choose a lower design frequency and extend the coverage from 51 to 54 MHz. This tactic is possible, but at a cost. The forward gain and the front-to-back ratio degrade continuously as we move above the design frequency. Hence, with a design frequency of, say, 52 MHz, the array

performance would not be very good at 54 MHz.

Building a Moxon Rectangle for 6 Meters

There is an unfortunate tendency among newer antenna builders to see a design they like and then to grab almost any materials close at hand and slap together a version that almost works. Many a good antenna design has gotten a bad name in some regions because builders did not exercise the same care in construction as the original builder. To obtain performance that agrees with the design notes above, acquire the right materials and then build the antenna with all the care possible.

A good tubing size for a 6-meter Moxon--whether horizontal or vertical--is 0.5". This size is useful, since we can use #8 or #10 hardware for fastenings. Of course, the hardware will all be stainless steel, both for rust prevention and to avoid bi-metallic contact problems.

For a 6-meter Moxon rectangle, we shall need 4 6' lengths of 1/2" diameter tubing. This size tubing can be shipped from suppliers like Texas Towers by UPS. (Yes, we shall have some scrap left over for use as garden stakes.) Use 6061-T6 or 6063-T832. Hardware depot tubing has an unknown vintage, so good quality antenna tubing is highly desirable. Do not use aluminum electrical conduit or copper tubing. The conduit is too heavy, and so is the copper in any form rigid enough not to gradually fold over on its own accord.

We shall also require a short (under 6") length of 3/8" aluminum tubing and a similar length of 3/8" diameter fiberglass or similar rod. We shall be constructing the elements in halves, so we need to join and align them. The short length of 3/8" aluminum tubing will join the two halves of the reflector, making them electrically one. The fiberglass or equivalent rod will align the driver halves, but allow a gap for connecting the feedline. Finally, we shall require some 3/8" outer-diameter fairly rigid tubing, something light but straight. These tubes will fit inside the ends of the driver and reflector tails to hold the spacing constant under all conditions.

For hardware, we shall require some #8 nuts and bolts, along with some locking washers. We can use sheet metal screws to fasten the tail junction tubes in place. However, all hardware must be stainless steel, including the washers. Since some of this falls outside what home warehouse hardware bins contain, consider locating a hardware supplier or use an on-line ordering source like McMaster-Carr. From such sources, you can also obtain a small sheet of 1/4" thick UV-protected polycarbonate (trade-name Lexan) to use as boom-to-element plates. Polycarbonate cuts nicely with woodworking saws and drills cleanly with standard bits.

The needs for a single Moxon rectangle are small, so you may wish to combine orders with others interested in the antenna in order to make up the minimum order requirements for a given supplier. Since we have vowed to be careful, we need not rush to get parts, but can go slowly and get everything we need.

For a boom, you can use either metal or Schedule 40 PVC (if the PVC in your area is adequately UV protected--this varies around the U.S.). In the southeastern US, white PVC gives me about 10 years of service before becoming brittle.

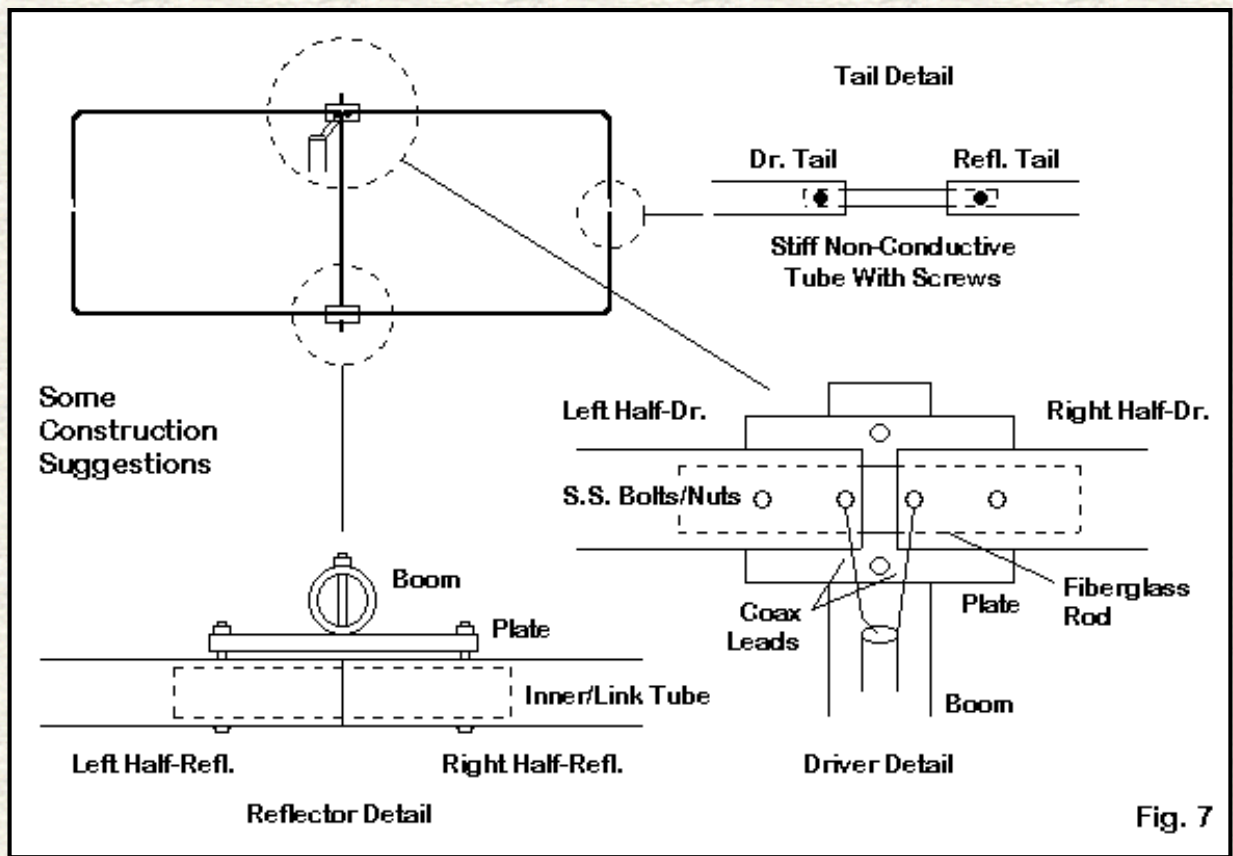

Fig. 7

Fig. 7 shows some of the suggested construction methods that I use. you may have better ones, in which case, use them. There are 4 keys areas of construction concern.

1. *The reflector junction:* A 3/8" section of tubing a little longer than the boom-to-element plate joins the two halves. If we use polycarbonate plates about 4" long and 3" wide, we have plenty of room for the elements and the nuts/bolts for boom fastening. A 1" nominal PVC pipe is actually about an inch and a quarter in diameter and is very rigid for a boom that is less than 3' long. For the plate-to-boom bolts, #10 hardware is very secure, using only 2 bolts per plate. However, use a compression lock washer against the plate or obtain self-locking nuts (with a nylon insert).

Since a #10 bolt requires a larger hole, you may wish to fasten the elements to the plate with #8 hardware, again with compression lock washers against the plate. (Toothed lockwashers may gradually loosen by gouging the polycarbonate.) For all drilling of the boom and the elements, make up a jig from scrap wood to pin the material in place while you drill. If you can gain access to a drill press--even a small device designed to hold an electric hand drill--by all means use it. Align all holes before drilling instead of widening holes later to bring parts into alignment.

2. *The driver gap:* By using a 3/8" fiberglass rod to align the driver halves, we can fasten the driver and the rod to the plate using #8 hardware. Note that there are two sets of hardware at the driver: an outer set to pins the element to the plate and an inner set to which we shall connect the feedline. If you prefer, you can set the connection hardware at right angles to the element-to-plate hardware to keep the coax more in line with the boom.

The sketch shows direct connections between the element and the coax, with no connector. I have found that from 6 meters on upward, connectors and their associated leads contribute reactance to the feedpoint impedance. A direct connection and a short length of coax taped to the boom for strain relief simplifies feedpoint construction. Once everything is complete, seal the connections, especially since solder terminals may not be available in stainless steel. Plasti-Dip or similar materials provide a weather-secure coating.

A note on the gap: The gap at the feedpoint is part of the overall element length (or dimension A), NOT an addition to it. Whether you start with a 1/4" gap or a much wider one, let the driver side-to-side dimension remain constant. In effect, the coax leads make up the seemingly missing tubing. The driver gap is not critical from 1/4" to over 3/4", but closer is always

better in this type of antenna.

3. *The tail separation:* Because we must keep the tail ends at a specified distance and aligned, we need a short piece of non-conductive tubing to lock their relative positions. Almost anything will do here, if it is 3/8" in outside diameter and relatively rigid. We shall need only about 4-4.5 inches exposed, so even flexible nylon tubing will work, although rigid plumbing CPVC is superior. You may use sheet metal screws to fasten the tube inside the tail pieces--after careful measurement, of course.

4. *The element bends:* Bending aluminum tubing requires care to prevent crimping that will eventually result in a metal crack and break. The radius of the corner bends will depend on the tubing size used. A plumber's tubing bender is applicable only up to about 1/4" diameter tubing. Larger tubing requires larger bend radii, and that means a home-made jig.

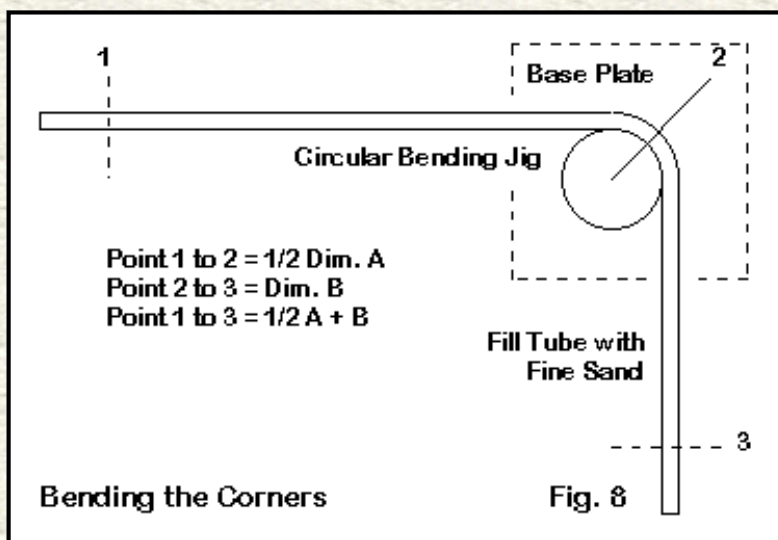

Fig. 8 shows a simple jig: a circle mounted on a base plate. The circle can be cut from plywood or be a pulley wheel. For larger radius bends, I have used such materials as a worn-out power mower wheel.

Mark a point on the 6' length of tubing that marks the center of the bent corner and leaves excess on both the tail and the parallel sections. Try to keep this mark at the center of the bend. As well, mark the tubing to indicate the parallel length (1/2 of dimension A) and the tail (B or D, as applicable). Fill the tube with the finest sand available and tape the end shut. If you prefer, warm the tube until it can just barely be handled with gloves. Pin one end of the tube (a nail in the base board will do) and slowly bend the tubing. The fatter the tubing, the more important it is to bend a few degrees and pause. Continue the bend until it is at least a 90-degree bend. A little more will not hurt, since a slight unbending of the tube does no harm.

Bend the tubing before you drill any mounting holes to make sure that all such holes are at right angles to the mounting plates. In fact, let's delay any drilling and do some work on the floor.

From the dimensions that apply to your tubing size, draw out the Moxon on the floor (or on paper taped to the floor). Be sure to mark the center or boom line as well as the points where the tails end. Next, lay the untrimmed bent pieces on the drawing. Because the corners are "clipped" by the bending, the pieces will just exceed the lines on the floor.

NOTE: For the adjustment of positions, be sure that the gap is constant and does not change!

With a constant gap distance as specified for the tubing size and measured against the marks made on the tubing, adjust the tube position to equalize the amount by which the tubes fall outside the original lines. At the same time, align the tubes. Now trim the tubes. Remember to trim a bit (1/8" or so per tube) off the driver to leave a gap for the coax connection. Smooth all cuts. Aluminum oxide sandpaper is best so that you do not leave residues of other metals on the aluminum. Clean the outer and inner edges of the tubes, since you will be inserting rods or tubes inside the main elements.

Now return to the assembly process and complete the Moxon rectangle. If you have used sufficient care, it should be right

on target on the first try. However, you can always trim a bit more from the reflector and driver tubes at their centers--and a little expansion that leaves a little inner reflector tube showing and widens the driver gap a small amount should do not harm.

I assume that you have a boom-to-mast plate and stainless steel U-bolt hardware. As well, I assume that the coax from the feedpoint has a connector and a double-female in-line connector. If those assumptions are correct, you are ready to put the Moxon rectangle into service.

Crossed Moxons

Suppose that you have both SSB and FM operations on 6 meters and that you decide that the Moxon has characteristics that are suitable for each job. Then you may wish to think about **Fig. 9**.

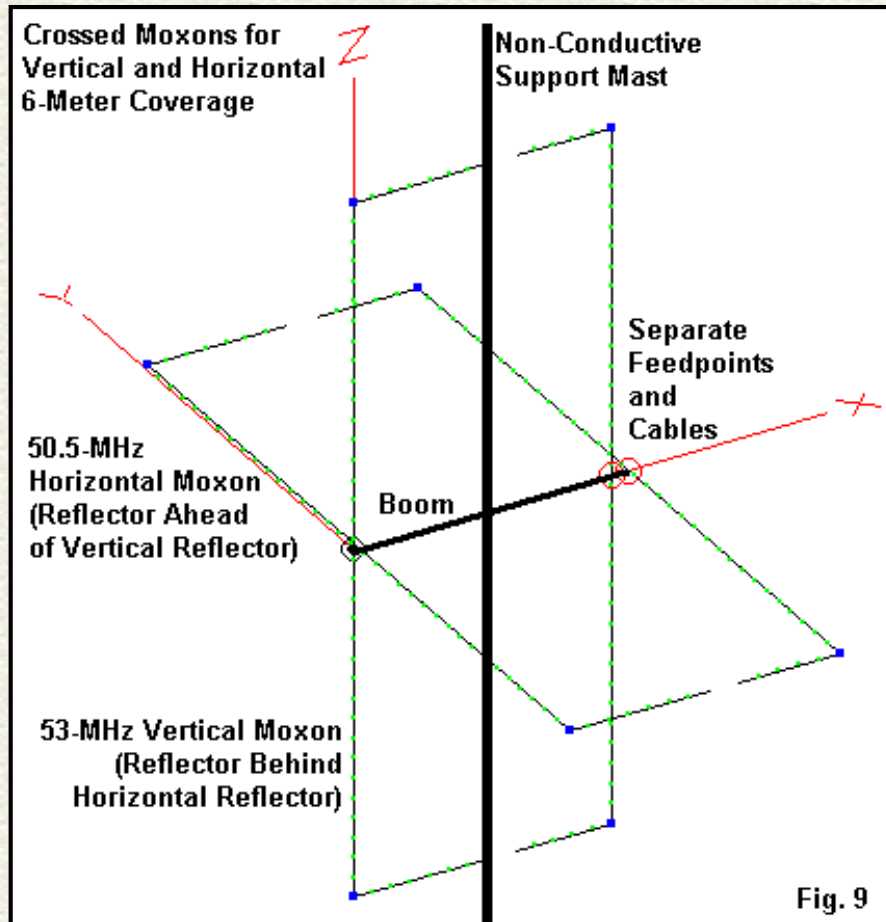

The outline sketches crossed Moxon rectangles. Since the low-end horizontal version is a bit larger than the vertical high-end version, let's place the horizontal reflector slightly ahead of the vertical reflector. Actually, it will make no difference if the two reflectors join at the center. However, we shall need physically separate feedpoints--and separate feedlines as well. However, the assembly will fit on a single boom.

Crossing Moxons and operating them separately makes no difference at all to the performance of either one.

One precaution applies to either a single vertical Moxon or to crossed Moxons: we shall need a non-conductive boom if we attach the mast at the center of the boom. (6-meter arrays are heavy enough where I do not recommend extending the boom rearward for attachment to a mast without a further extension and counterweight.) Schedule 40 PVC has two sizes that nest reasonably well for stiffening the material for mast use: 1" inside 1-1/4" nominal (closer to 1.25" and 1.5" actual outside diameters). You will need about 3.5' to go from the boom to the edge of the vertical Moxon and perhaps another 2' above any metal structure (like a tower), plus a few more feet to reach a rotator. (An old TV rotator is more than sufficient to handle even the crossed Moxons). However, do not use more PVC mast than you need to do the job.

A Wire Moxon for 6 Meters?

As a final note, we should address the question of making a wire Moxon. A #12 or #14 copper wire Moxon is feasible for the horizontal version only. However, the thin wire will narrow the passband severely. If you operate within a very narrow spread of frequencies at the low end of the band, then you may consult one of the design aids and set up a wire version. It will perform well--as well as the tube version. As well, it may be easier to make sharp corners and trim to length.

However, a wire version of the vertical Moxon is likely to prove unsatisfactory for repeater hopping. It will work well for monitoring a single repeater--or a couple that are within a half-MHz of each other (allowing for the frequency split). However, for general coverage of the FM region of 6 meters, a version with fatter elements is strongly advised.

We can illustrate the opportunities and the limitations of a wire Moxon for 6 meters with a simple example. Let's design a wire Moxon for horizontal use around the design frequency of 50.5 MHz. The dimensions will be as follows:

.....

Dimensions for a 50.5-MHz Moxon Rectangle

| El. Dia. | A | B | C | D | E |
|-------------------|-------|-------|------|-------|-------|
| AWG #14 (0.0641") | 84.86 | 12.53 | 2.61 | 15.95 | 31.09 |
| 0.25 | 84.31 | 11.65 | 3.44 | 16.08 | 31.18 |

.....

I left the figures of the quarter-inch version for comparison. As shown in **Fig. 10**, the wire Moxon has a steeper gain curve and a sharper front-to-back curve than the tube version of the same antenna. However, for local and net operations, these figures may be very adequate.

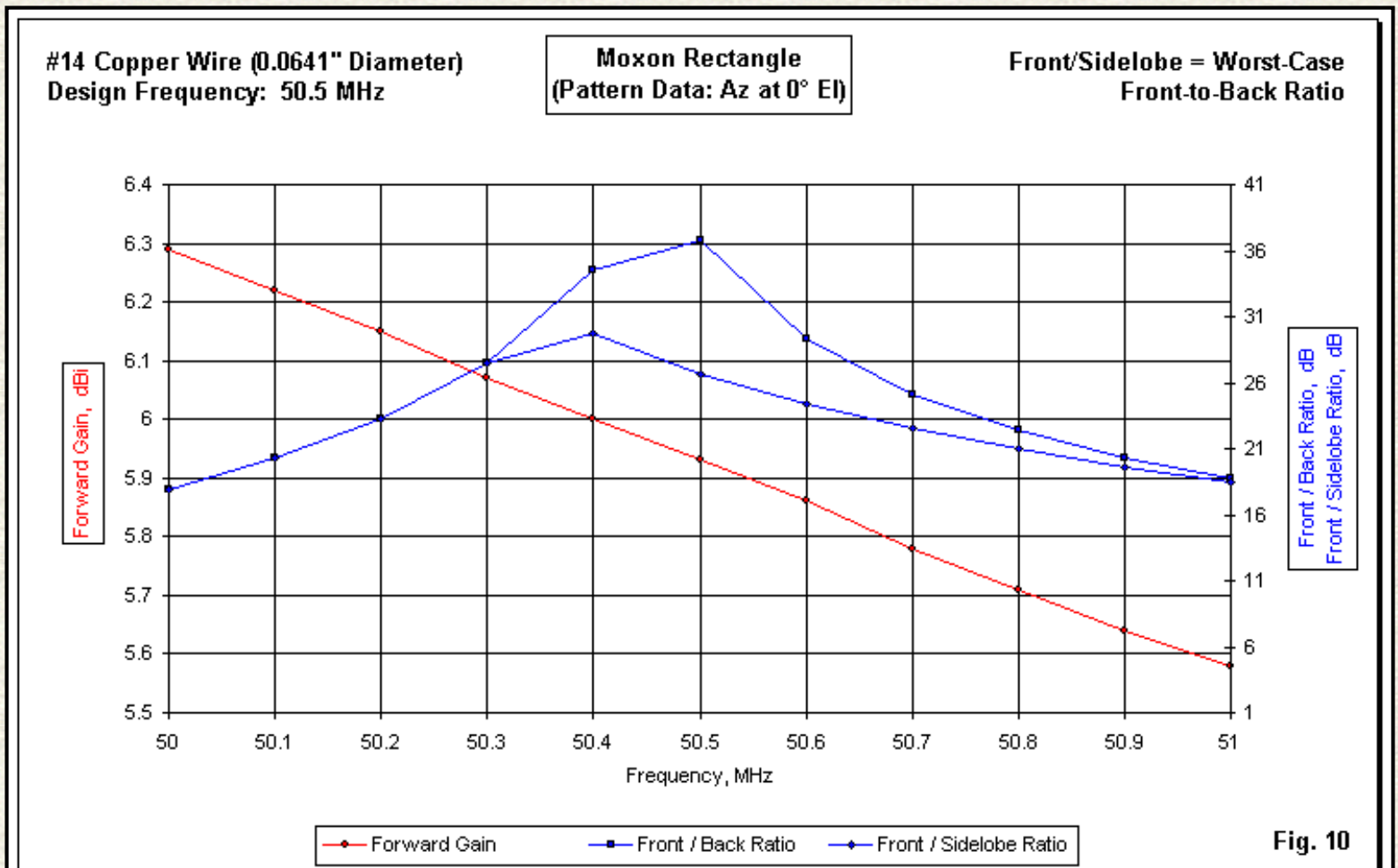

Fig. 10

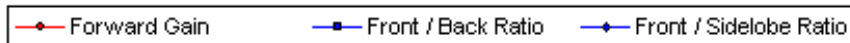

Fig. 10

The SWR curve, while steeper than the ones for the tube versions of the antenna, guarantees coverage of the first MHz of the band. See Fig. 11. You may note in the two graphs that the front-to-back ratio peaks just below the design frequency, as does the 50-Ohm SWR curve.

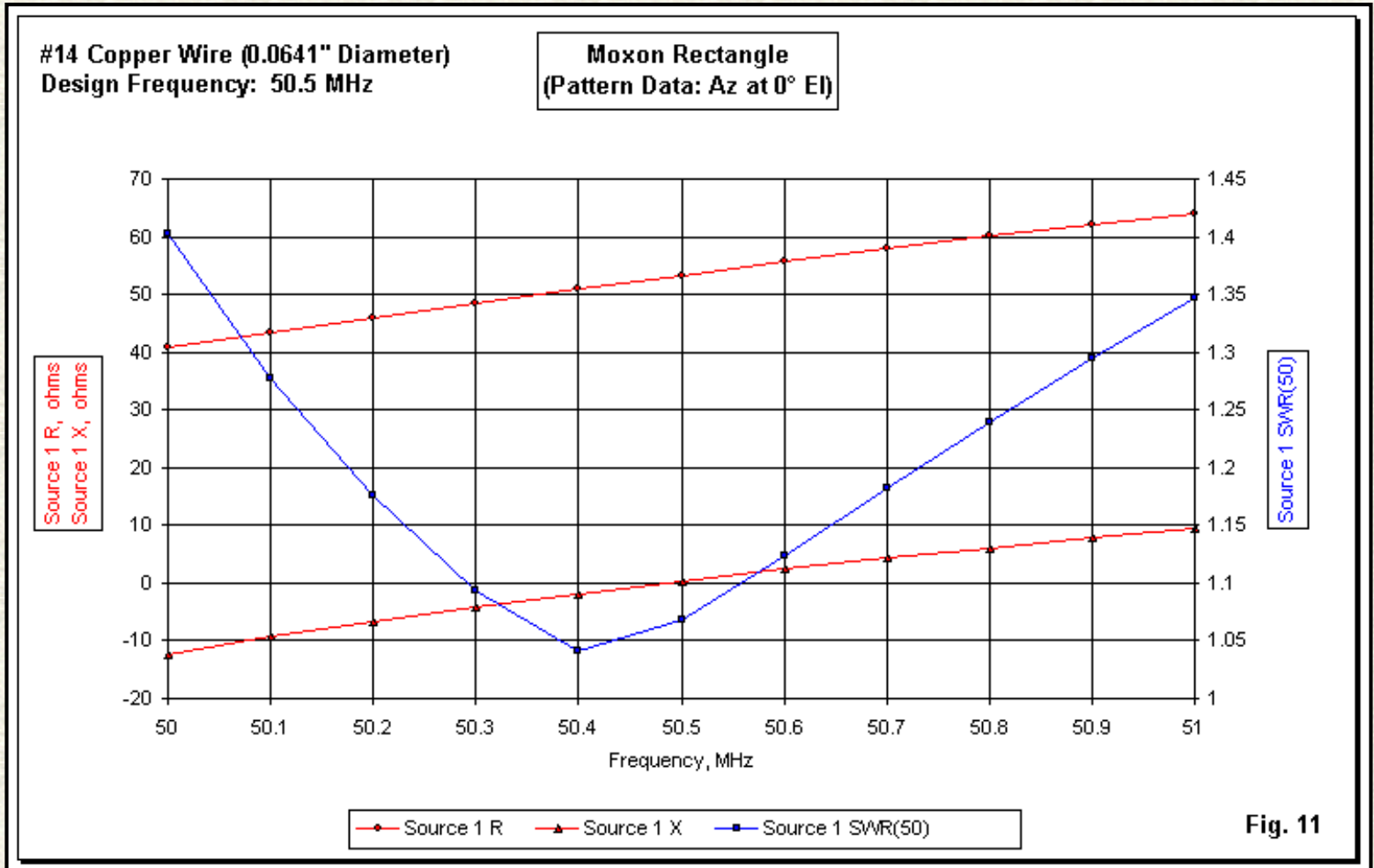
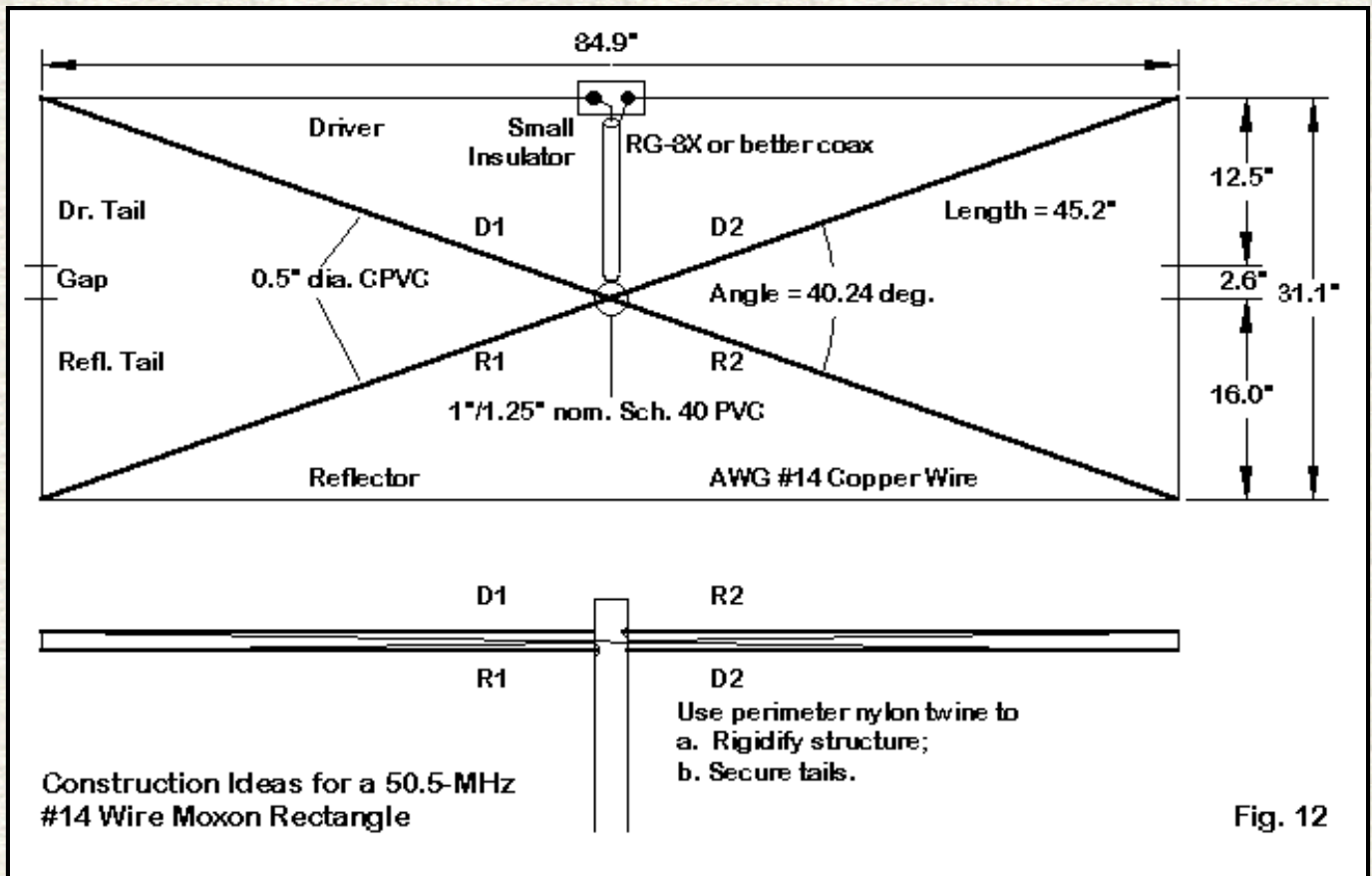

Fig. 11

You can make the frame from 1/2" or 3/4" CPVC. By passing the frame through carefully aligned holes in a central Schedule 40 PVC mast, you can cement the structure together. Each cross arm will need to be just over 7.5' long (3.75' each side of the mast). As well, you will have to plan your angles for the holes carefully to get the correct shape between corners. However, if you are only a little off, you can stress the arms with Nylon line (1/8" to 3/16") to perfect the shape of the ultimate support structure. If you adjust the holes in the mast, then add through bolts to finalize the positions of the support arms. The details of a suggested construction for the frame, line, and wires appears in Fig. 12.



Even if you get the angles between supports correct, you may still run a length of nylon or similar line from the corners along the line of the tails. Then, tape the tails to this line, and the ends (raw cut and not looped) will stay in alignment and maintain their spacing. (I tend to prefer to use a full perimeter line to pre-stress the frame so that it maintains its shape under all conditions.) The resulting wire Moxon very likely will be considerably cheaper than any of the tube versions, since we can make it from PVC and household wire, along with a little hardware at the feedpoint.

Whether the Moxon is the right antenna--and which version is the one to build--depends on your own analysis of operating needs. Do not build one unless it will do the job that you need. But if you do build one, build it carefully, and it will work correctly without further field adjustment.

Updated 02-03-2003. © L. B. Cebik, W4RNL. Data may be used for personal purposes, but may not be reproduced for publication in print or any other medium without permission of the author.



[Return to Amateur Radio Page](#)



Click here for more information!

Find on this site...

Site Index

•Exams Search site: Call sign search:
 •Clubs
 •Hamfests
 •Addresses

ARRL Member Login...

Username: Password:

[Register](#)

Quick Links...

•[Join or Renew](#)
 •[Catalog & Store](#)
 •[ARRL Courses](#)
 •[Classifieds](#)
 •[Getting Started](#)

[Operating Activities](#)

[Licensing](#)

[News/Bulletins](#)

[Services](#)

[Educational](#)

[Public Service](#)

[Support](#)

[Donate to ARRL](#)

[ARRL Info](#)

[Text-only/Printable](#)

The VHF Beam/Yagi Antenna

[ARRL Technical Information Service page](#) · [TIS Menu page](#)

Additional information on this subject and related topics can be found in back issues of [QST](#) and the following:

[The ARRL Antenna Book](#)

[Physical Design of Yagi Antennas](#)

The [ARRL](#) has an extensive [catalog](#) of books and materials related to [Amateur Radio](#).

Articles

Note: Some of the following articles are in Adobe Portable Document Format (PDF) files. To view and print these files, you'll need a copy of Adobe's Acrobat Reader program. (Version 3.0 or later required). More information [here](#).

- [Homebrewing a 6-Meter Yagi](#) (from *QEX* RF column) **MEMBERS ONLY**
QEX January/February 1998, p. 52-57
In typical Zack Lau, W1VT fashion, the element and mounting clamps are machined, but good ol' hose clamps and hardware store mast mountings will work on this 4-element antenna.
- [Small 70-cm Yagi](#) (671,292 bytes, PDF file) **MEMBERS ONLY**
QEX July/August 2001. pp. 55-59
A 6-elements designed for a wide bandwidth.
- [2x3=6](#) (84,913 bytes, PDF file) **MEMBERS ONLY**
QST February 2000, pp. 34-36
Two three-element 6-meter Yagi designs.
- [7dB for 7 Bucks](#) (844,127 bytes, PDF file)
QST April 1993, pp. 54-55
An inexpensive 3 element 2-meter Yagi made from PVC and welding rod.

ARRL Products:
Contesting
[\(More\)](#)



5-Band Worked All States Pin --

Colorful design. 1-inch diameter pin with self-locking "tack" backing.



The Ham Radio Olympics (video) --

Exciting 27-minute video about the World Radiosport Team Championships (WRTC) 2000.



HamCall CD-ROM --

Latest US & International call sign listings. CD-ROM.



Worked All States Pin --

You won the award...now show off your accomplishment!



DXpeditioning-- Behind the Scenes

-- A manual for DXpeditioners and DXers, covering virtually all aspects..from

- [A Five-Element, 2-Meter Yagi for \\$20](#) (457,324 bytes, PDF file)

planning to operating,
traveling, QSLing, and more!

MEMBERS ONLY

QST July 1999, pp. 34-37

Get about 10dB from a modified Radio Shack FM broadcast receiving antenna.

- [Circular Polarization and OSCAR Communications](#) (1,401,889 bytes, PDF file) **MEMBERS ONLY**

QST May 1980, pp. 11-15

OSCAR users are switching to circular polarization to lessen signal fading. Build this low-cost antenna system and hear what you've been missing.

- [A Tri-Yagi for 50 MHz](#) (862,492 bytes, PDF file) **MEMBERS ONLY**

QST June 1980, pp. 14-15

For the performance of a 6-element wide-spaced beam on a boom half its normal length, try this "trigonal" reflector scheme.

- [An LPDA for 2 Meters Plus](#) (839,246 bytes, PDF file) **MEMBERS ONLY**

QST October 2001, pp. 42-46

This Log-Periodic Dipole Array (beam) antenna covers 130-170 MHz for those who also like monitoring.

Note:

Contact information for suppliers mentioned in the above articles should first be confirmed using [TIS Address Database Search](#).

Bibliography (Members Only)

[ARRL Periodicals Index Search](#) - This database contains the *QST* index from 1915 to the present and the *QEX* index from 1981 to the present. For *QST* issues from 1970 to the present, and some selected articles back to 1922 (when construction articles featuring tubes began in earnest), identifying keywords have been added to the technical articles. By entering keywords (ANTENNA) or combinations of keywords (CONSTRUCTION ANTENNA VERTICAL HF) into the **Title words:** field, you may create dynamic bibliographies.

Technical article [KEYWORD list](#). [Hints for more successful searching](#)

Suggested keywords for more articles like the ones on this page are: [CONSTRUCTION VHF BEAM ANTENNA](#)

Web Links:

- [The Tiny 2](#)

The "Tiny 2" is a great little 2 meter beam. It has some really interesting properties and it is a fantastic first time antenna project for the beginner.

- [The Tiny 2+1](#)

Renamed the Tiny 3. As with any standard three element design, this three element direct connect antenna utilizes a reflector and a director to achieve gain.

- [VHF / UHF Direct Connect Beams](#)

Here are some lengths and spacings for various direct connect beams.

- [2 Meter Antenna Design Gallery!](#)

- [Antenna Round Up](#)

Antennas for 6, 10 and 2 meters

- [Stacking Yagi Antennas](#)

- [A Simple Seven Element Yagi Antenna](#)

A JavaScript that quickly calculates the dimensions for a seven element Yagi Antenna. Simply enter the frequency in Megahertz and the script will do the rest.

Article Reprints:

Note: Reprints are available from the Technical Department Secretary, ARRL, 225 Main Street, Newington, CT 06111. Article copies must be prepaid \$3 for ARRL Members, \$5 for non-members. You may order by telephone (860-594-0200) and pay by credit card. Reprints can only be sent by mail and cannot be sent by or attached to e-mail.

This information was prepared as a membership service by the American Radio Relay League, Inc., Technical Information Service, 225 Main St., Newington, CT 06111 (860) 594-0214. Email: tis@arrl.org (Internet). ARRL HQ is glad to provide this information on the Web free of charge as a service to League members and affiliated clubs.

If you have any questions concerning the reproduction or distribution of this material, please contact:

TIS Coordinator
American Radio Relay League
225 Main St., Newington, CT 06111
Tel: 860-594-0214 Fax: 860-594-0259
(email: tis@arrl.org)

Page last modified: 08:55 AM, 09 Oct 2003 ET

Page author: tis@arrl.org

Copyright © 2003, American Radio Relay League, Inc. All Rights Reserved.

A Six element antenna for the 50 MHz Amateur Radio Band / Version 4

© Christoph Petermann DF9CY 1998

Last Update: 31 May 2001



[A better view of the 6 element](#)

I have mounted the 6 Element antenna about 2 meters above my 3 element antenna for 28 MHz. (The 28 MHz antenna is a well performing "EZNEC redesigned" CB radio antenna)

This plot shows the antenna "as seen" by the computer.

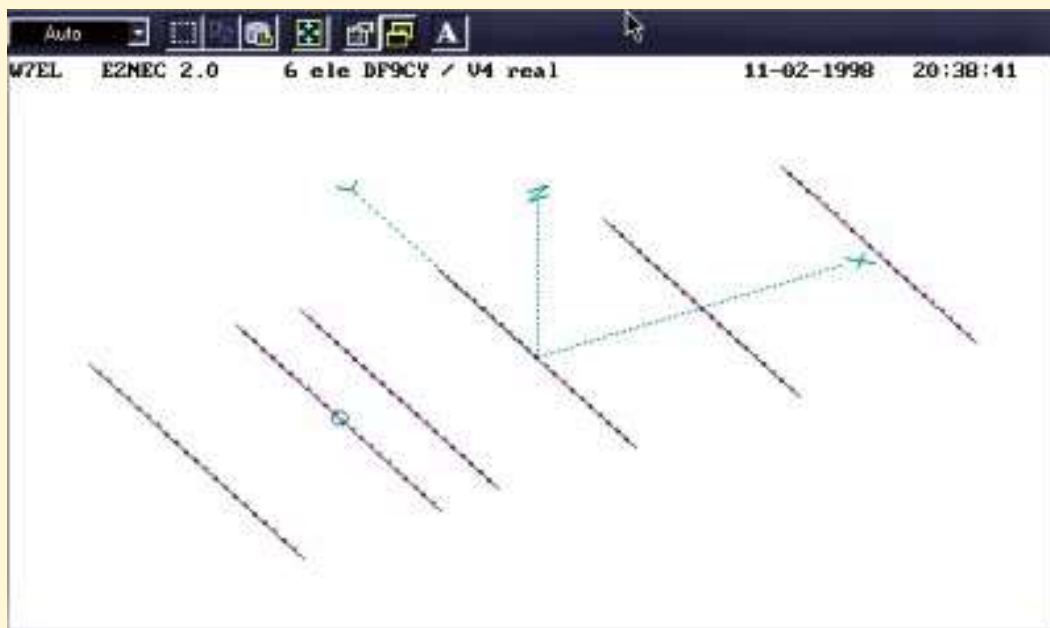

Here is a short description of my new **SIX** element antenna.

Design Frequency: 50.150 MHz

- **Usable Bandwidth: 500 kHz**
- **Return loss: better than 10 dB within 500 KHz with 22 dB @50.150 MHz.**
- **Gain: > 11.2 dBi**
- **Front/Back ratio: > 12 dB**
- **Vertical sidelobe suppression: > 12 dB**
- **Horizontal sidelobe suppression: > 19 dB**

Version List

- **Version 1:** Only a simulation version.
- **Version 2:** Has been published here. Version 2 has slightly changed element lengths and positions over Version 1. Gain has been reduced to 11.3 dBi, but it has an even better bandwidth performance. The first antenna of this type (Version 2) has been built by **Hellmuth, DF7VX**. It seems to work reasonably well. The design goal's resonance frequency has been hit exactly. Hellmuth is using this antenna since the 1998 Es season and worked a good number of DX stations with it. I have built a 2nd antenna and tried out a number of different feeds with it. This included folded 200 Ohms dipoles and Gamma matches.
- **Version 3:** This version was published here in July 1998. It has been built several times in England and America with good success.
- **Version 4:** The previous version suffered from having the resonance frequency a little low. I made some minor changes. This antenna is ready in operation here now and I am delighted with its performance in 12m above ground. It has a clean pattern with a good front/back ratio. SWR is excellent and broadband at least over the DX portion of the 6m band. It outperforms well the 4

element I have described here also.

- **N7BW Realisation** Here is a version built by John N7BW. The [6-ELEMENT](#) and the [FEED-POINT](#), at the driven element with an open dipole. (Images)

| ELEMENT # | POSITION | center-to-end element length | Diameter |
|---------------|---------------|------------------------------|--------------------|
| | <i>Meters</i> | <i>Meters</i> | <i>Millimeters</i> |
| Reflector | 0 | 1.450 | 12 |
| Dipole | 1.114 | 1.385 | 12 folded dipole |
| 1 st Director | 1.585 | 1.328 | 12 |
| 2 nd Director | 2.657 | 1.328 | 12 |
| 3 rd Director | 3.942 | 1.327 | 12 |
| 4 th Director | 5.327 | 1.320 | 12 |

Driven Element

- I strongly recommend building a folded dipole. I did have VERY poor experiences with Gamma Matches in the past. They are for low impedance antennas only and they provide the necessary transformation. So they are narrow banded and if you have not the high quality material at your hand, you will sacrifice some of your gain you have made the antenna for.
- A folded dipole needs a balun: take a good cable like RG400 teflon for it. The velocity factor of this cable type is 0.82; a length of 2.45m will do the job. It is expensive, but you want the DX, don't you?
- If you do not want to build a folded dipole, make an open dipole mounted insulated from the boom. A 1:1 RG400 transformer is built within 10 minutes and -voila- you have your antenna going.
- I designed the antenna for 50 Ohm (i.e. 200 Ohms if you have a folded dipole).
- TIP: Buy the complete folded dipole from [KONNI Antennen in Esselbach](#)

Elements

The diameter of the elements is 12 mm AND NOTHING ELSE. The antenna will not work, if you take something else. (J'espère, que c'est O.K., Jaques ?) The elements are mounted insulated above the boom. I have about 4 mm space from the boom to the elements. I use industrial spacers mounted with a 4 mm metal (!) screw centric to the 20*20mm boom. The deviation from an element being really isolated is minimal. Indeed I bought the whole element at [KONNI Antennen](#). Buy reflector elements only and cut them to the given length.

BOOM

This antenna is calculated for a 20*20mm of 2 mm strength boom which I made from material from a metal shop and some scrap from Tonna 2m Yagis ...

I replaced the support boom you see on the image by a longer one. This gives more strength. In February

1999 the antenna survived a monstrous wind storm with gales up to 165 km/h.

Interactions

If you put this antenna on top (or below) your existing antennas: be aware that you reduce the antennas' performances. Keep this antenna at least 3.0 m away from ANY shortwave antenna and about 1.5m from other VHF antennas.

Stacking

If you are intended to stack 2 antennas, space them minimum of 1/2 wavelength. At half wavelength, the existing vertical sidelobes wil DISAPPEAR with a gain around +2.1 dB. Stacking the antennas at 1 wavelength increases stacking gain to about 2.7 dB and sidelobes go up. I would like to space 2 antennas at 1/2 wavelength, but the space on the tower is limited.

Performance

I have been reported and I can confirm myself: That antenna works. I see a clear pattern with the antenna up at 12m. There is almost no sidelobe and the F/B ratio is good. The SWR is also as expected.

It clearly outperforms the 4 element I did have up here through 1998. It is not more than 2.5 dB (or half a S-unit), but having more energy at the horizon gives you an extra advantage. The OZ7IGY beacon at 200 km line of sight is up about 2 S-units now (I am wondering myself ...) and the other beacon OZ6UHF at 300 km is also better now.

After a few months I can say, the antenna does a very good job. Tropo signals are often audible over distances of more than 400 km.

After 2-1/2 years ... (May 2001)

I am still very pleased with the performance of the antenna. It withstood all brute gale winds here in my "seaside-resort". But 30 black birds (ravens) destroyed the antenna completely already twice. Now I have an 8 mm aluminium tube in the centre of on element strengthening against the weight of these birds. DX performance is better than everything I had before. I like the clean pattern. Certainly the front/back ratio of 12 .. 15 dB could be better, but you can have this by giving up the clean pattern and some gain. I know of about at least 12 hams having built this antenna and so far all are quite pleased with it. I would like to have a stacked version of two at a spacing of 4m, but my antenna tower is somewhat weak for that. My feedline is a 22m run of AirCell cable. I get a strong enhancement in noise when I turn the antenna across the galactic centre in summer. I had a low noise GaAs-Fet amp at the antenna for a while, but this was not necessary; so it is down again. In October 2000 I moved the antenna from 10.5m to 13m above ground level. The patterns became even cleaner and I succeeded in nice F2 QSOs to Far-East and the U.S.. The nicest thing however is to work the DX with a flawlessly well-performing homemade antenna.

EZNEC

I provide you with the EZNEC simulation. So download the EZNEC-FILE: [50-6cy4r.zip](#)

DIAGRAMS AND SIMULATIONS

Below are the diagrams for the azimuth plane (upper) and the elevation plane (lower). Sidelobes are barely visible in the azimuth plane and well 12 dB below maximum gain in the elevation plane. These are the free space simulations.

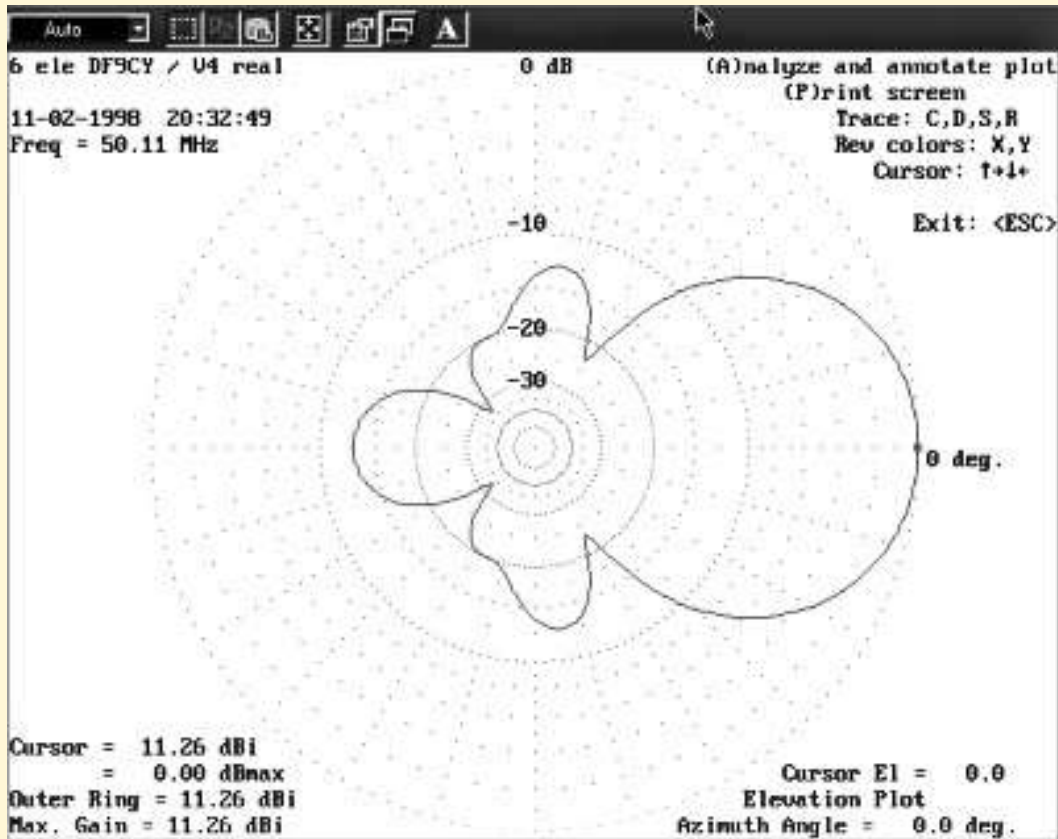
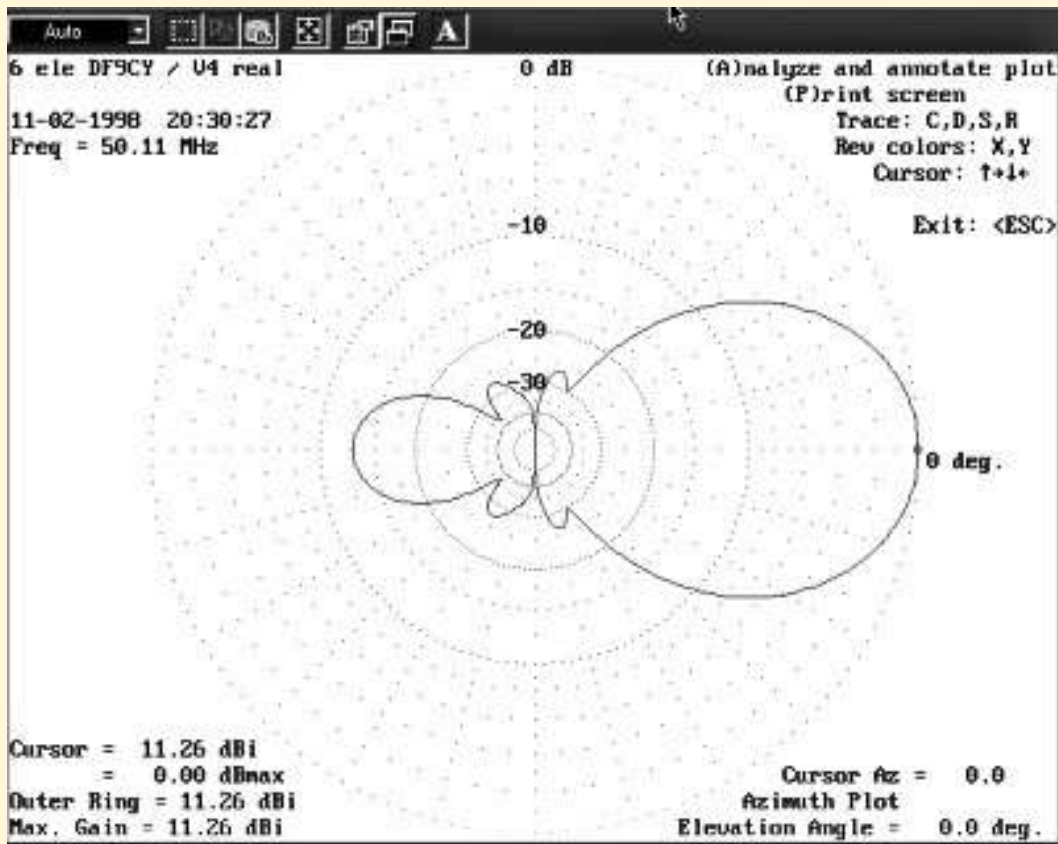

The SWR plot shows the optimum SWR at 50.110 MHz

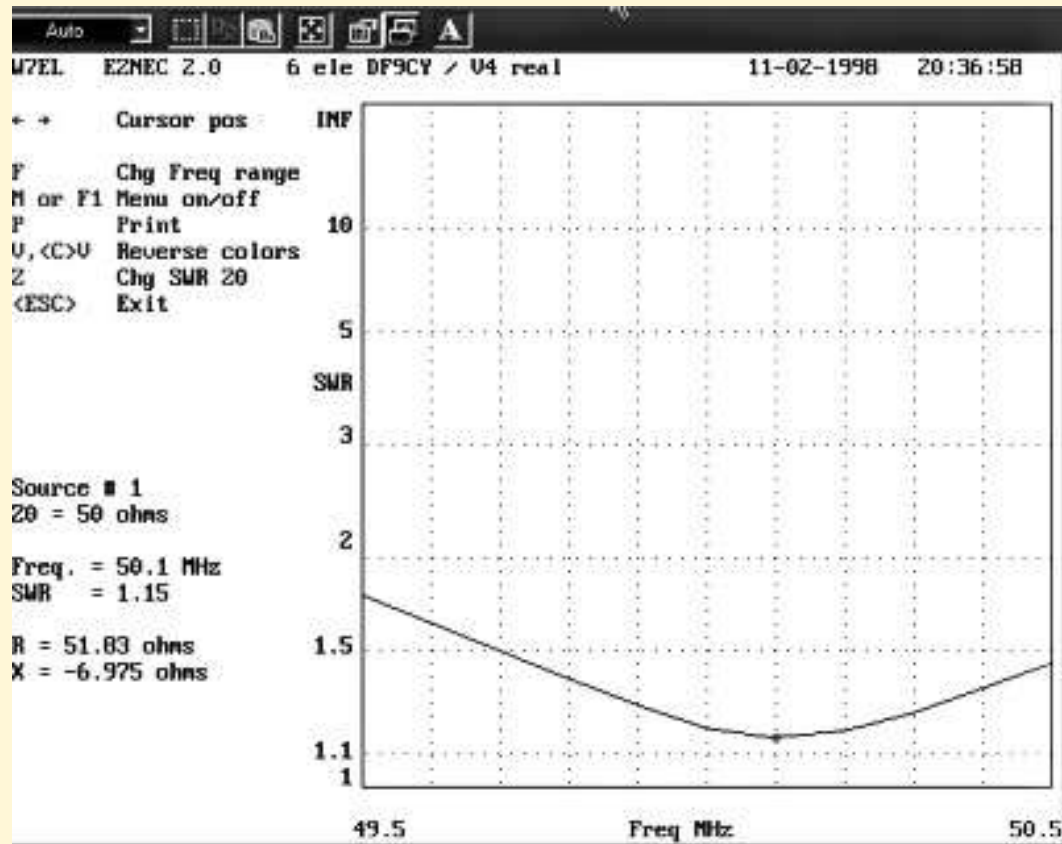

This simulation shows the elevation pattern over real ground with the antenna mounted at 10 meters above ground.

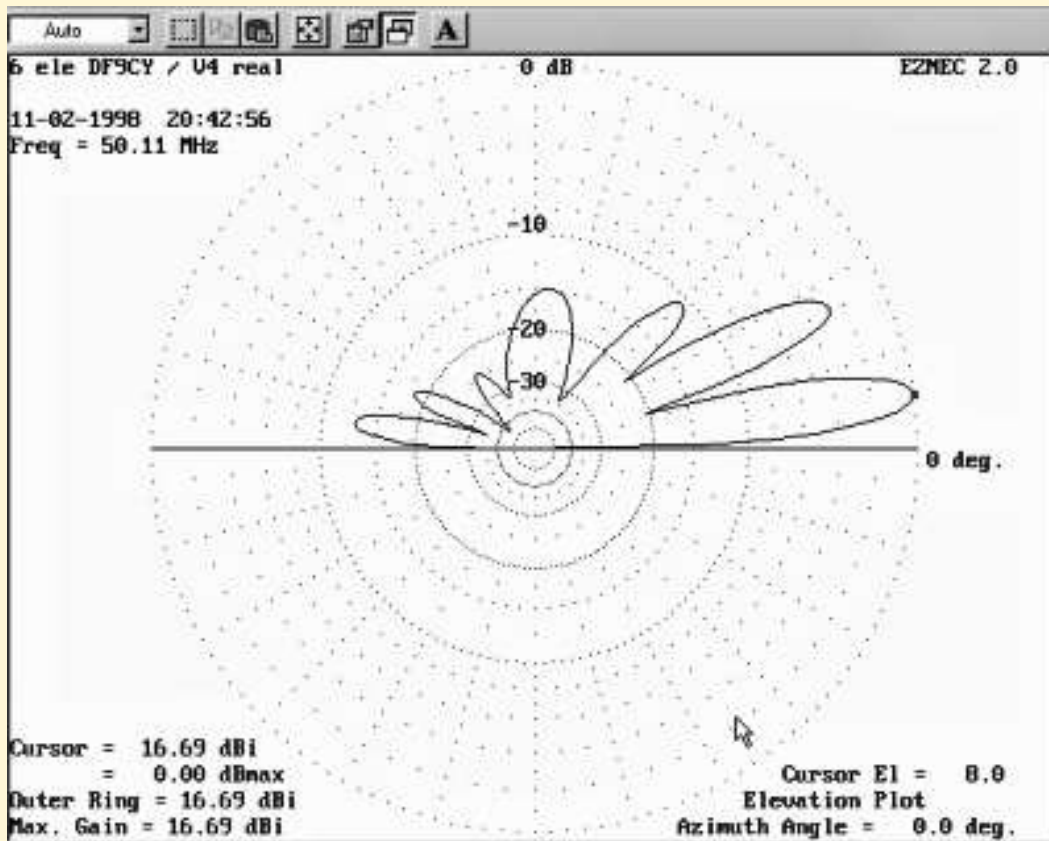

My special thanks go to Roy Lewallen W7EL for programming this fantastic *EZNEC 2.0*

If you want to have more background knowledge on antennas and how-to make them, you will find an ultimate resource here:

[W4RNL](#)

L.B.Cebik W4RNL ultimate ANTENNA Site. A must !

Mail any comments to: df9cy.petermann@t-online.de

Text and All Images are Copyright by Christoph Petermann DF9CY

GO (back) and visit my [homepage](#)

Antennas: (updated Feb 25, 2002)

8 element, 41 foot boom, mounted at 87 feet. 14.0 dBi gain, homebrew design (pictured on homepage) used for F2 & multi-hop Es: 1.75" diameter boom, center section has .125 wall, all others .062 wall..250" dia elements thru the boom insulated, add 8.7% boom diameter to element length for this boom. Tee match, 1.150" spacing, .250" diameter bars, length = 11.5 inches each side, fed with half wave length coaxial cable balun from UT250 with shorted and grounded quarter wave length stubs each side of Tee match. The grounded quarter wavelength stubs did absolutely nothing for suppressing rain static nor summer time "dry air static" common to this area. Will leave them out next time. Driven element dimensions may be too short as I forgot to re-measure it after final adjustments were made....will do that next time down. So far this cycle this antenna has performed extremely well on the F2 and TEP paths. Its clean pattern has paid off on suppressing noise and local QRM while looking for DX.

| Element | reflector | driven ele. | dir #1 | dir #2 | dir #3 | dir #4 | dir #5 | dir #6 |
|---------|-----------|-------------|---------|---------|---------|---------|---------|---------|
| Length | 116.276 | 112.600 | 109.534 | 107.556 | 105.776 | 103.754 | 102.700 | 104.754 |
| Spacing | 0 | 28.530 | 69.265 | 134.597 | 213.310 | 306.557 | 408.697 | 488.066 |

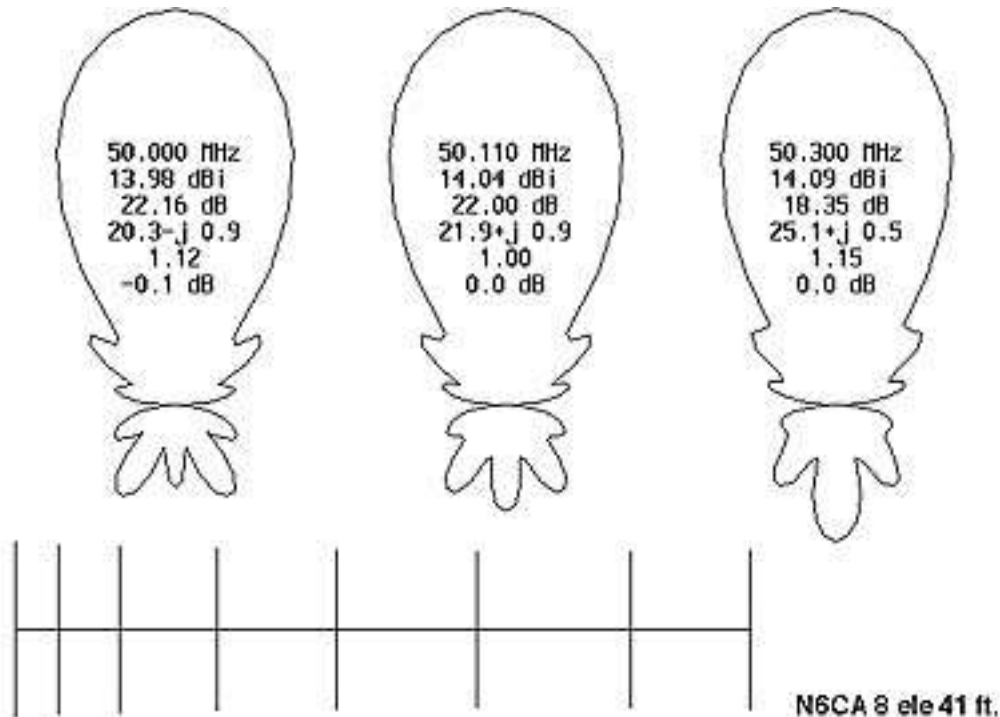

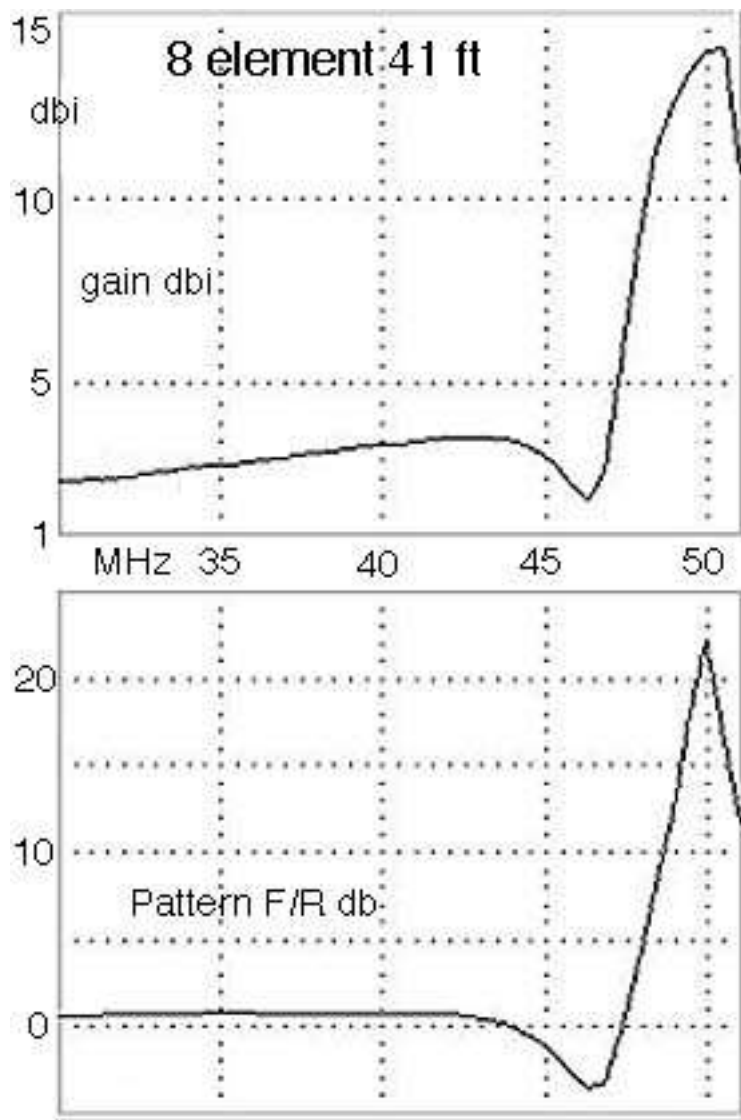

4 element broad band yagi

This antenna was the final choice for the all purpose noise cancelling/MUF antenna. It has a super clean pattern yet and enough gain to be useful. Too much gain would make it harder to use in noise cancelling applications. It is designed for many uses: 1) noise source antenna for the noise cancelling receiver. 2) a 43 to 51 MHz antenna for observing MUF as the band opens up. 3) as a secondary wider beam width six meter antenna. All of the aforementioned points require an antenna design with a good pattern, reasonable gain and good impedance.

Compare the gain-bandwidth of this antenna to the rather narrow gain-bandwidth of the 8 element yagi above. Many MUF indicators are between 40 and 50 MHz. Mounting tests will be performed first to assure there will be adequate isolation between the 8 element yagi and this one. I do not want any deterioration of the 8 element yagi's performance. They will be 3/4 wavelength apart (15 feet). There should be around 20 db isolation between the two antennas (17 db measured...yuk!). I'm still amazed at the computer performance of this antenna considering the bandwidth....

The boom is 9 foot 7 inch, long 1 inch OD 0.065 wall. Elements are .250 inch diameter alu tubing as usual and are thru the boom and insulated. The driven elements are split in the middle and mounted on Delrin blocks. The phasing/matching lines made from UT141 semirigid coax (only outer conductor used). Impedance of the open wire line isn't that critical and can run anywhere from 70 to 100 Ohms without much effect. Add 5.1% of the boom diameter for thru the boom insulated compensation to the element lengths for this boom. Results of testing will be posted when I get them. Antenna seems to perform as expected. Better signal to noise ratio than big yagi at lower freqs and of course great directivity. Impedance is as computer predicted at <2:1 due to higher impedance openwire feeder to eliminate water accumulating between the conductors. The output of this antenna is split or switched to drive the filter/preamplifier/R8500 and the noise cancelling receiver. It's a great ant with multiple uses for us one tower guys. A separate low power T-R relay is used to isolate the output of this antenna when transmitting on the 8 element yagi.

| Element | reflector | driven ele, #1 | driven ele. #2 | dir #1 |
|---------|-----------|----------------|----------------|--------|
| Length | 131.05 | 119.7 | 112.6 | 104.2 |
| Spacing | 0 | 30.39 | 75.97 | 113.0 |

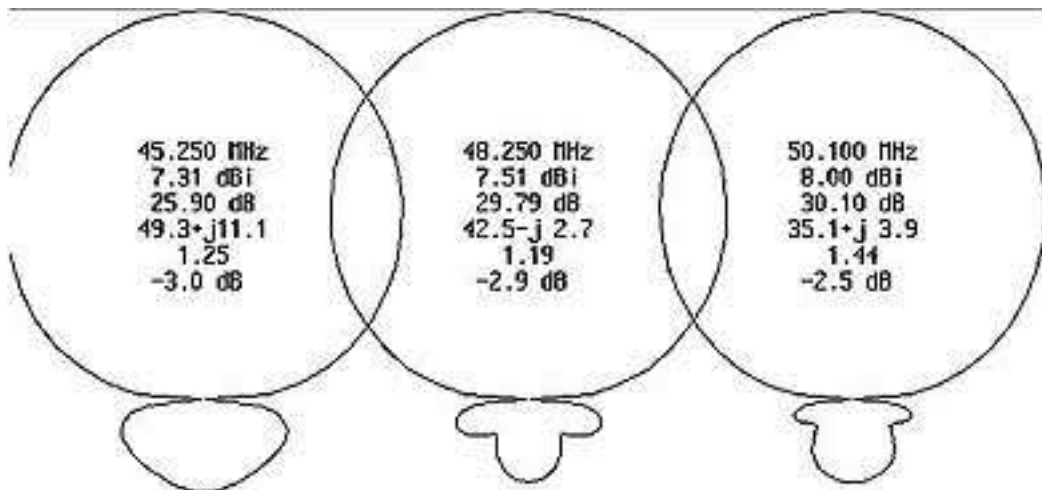

| Elements | | |
|----------|----------|---------|
| | Position | Length |
| Ref | 0.000 | 65.526" |
| DE 1 | 30.389 | 59.855 |
| DE 2 | 75.972 | 56.310 |
| Dir 1 | 113.009 | 52.105 |
| Boom | 9' 5" | 0.46λ |

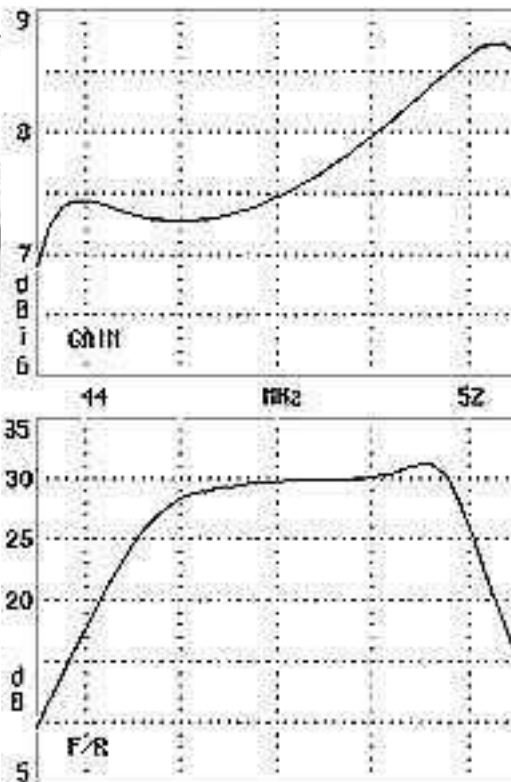

Open wire feeder made from UT141 semirigid coax, only the outer conductor is used, spaced .150 inches. This is greater impedance than the 80 Ohms so it won't collect water between the conductors. It is important to maintain the air dielectric. Delrin spacers are used throughout. Balun is ferrite beads on outside of coax held in place with shrink tubing.

6 element , 24 foot boom, 12.1 dBi design used for Es: Units=inches, .250" dia elements thru the boom insulated, 1.0" diameter with .125 wall center section and all others .062 wall. Add 5.1% boom diameter to element length. Tee match, 1.150" spacing, .250" diameter bars, length = 14 inches each side, fed with half wave length coaxial cable balun, RG142.

| Element | reflector | driven ele. | dir #1 | dir #2 | dir #3 | dir #4 |
|---------|-----------|-------------|---------|---------|---------|---------|
| Length | 116.227 | 113.50 | 109.720 | 107.170 | 105.708 | 103.436 |
| Spacing | 0 | 40.5 | 80 | 142 | 216 | 287 |

4 element , 15 foot boom, 10.8 dbi gain, designed for light weight portable antenna. Clean pattern: all lobes >-21 db. Usually run on 21 foot mast. Boom = 1.0 inch diameter with .062 wall. .250 diameter elements with .049 wall. Thru the boom insulated elements in table above already have add 5.1% diameter of boom (.050 inches) added to element lengths. Tee match: .250 diameter rods, 1.0 inch spacing, 12.75 inch length on each side from boom center with 1.625 inches protruding beyond shorts. Shorts are made from 1/4 x 1/2 inch copper bar. RG142 half wave length coaxial balun. Antenna picks up 1 db gain over the shorter boom 12 footer. This one built with splice at the driven element for easy assembly while portable.

| Element | reflector | driven ele. | dir#1 | dir#2 |
|---------|-----------|-------------|-------|-------|
| Length | 115.4 | 112.55 | 107.6 | 106.2 |
| Spacing | 0 | 47.7 | 108.5 | 177.7 |

3 element, 5.2 foot boom, designed for super clean pattern (side lobes > -29 dBc) and low gain! Antenna used for 50 MHz noise cancelling receiver. Half wavelength coaxial balun, RG -142. Units=inches, .250" dia elements thru the boom insulated, 1.0" diameter boom, add 5.1% boom diameter to element length. Tee match 1.0" spacing, .250" diameter bars, length = 11 inches each side, fed with half wave length coaxial cable balun.

| Element | reflector | driven ele. | dir #1 |
|---------|-----------|-------------|--------|
| Length | 118.0 | 114.2 | 106.5 |
| Spacing | 0 | 24 | 62 |

All antennas were designed with YO, Yagi Optimizer.

Radio:

Homebrew hi level transverter, Rx filtered for 50 to 51 MHz pass band, -45 dBc at 54 MHz, noise cancelling input, adjustable phase & gain. 22 dB conversion gain, 2.5 dB noise figure. Terminating low pass filters on Tx.

Incorporating a FT1000D modified for use as the primary 50 MHz IF radio. TS930 had more than 60 thousand hours of six meter operation on it. (tired). First IF filters need to be added to FT1000D. and similar to 930 transverter mods need to be incorporated but I am finally using it. Going to add a new 8 pole first IF filter, PIN atten and hi level bipolar first IF amplifier replacing the original dual gate mosfet aa 73 MHz.

Icom R8500 receiver used for band segment scanning and third receive frequency. Adding a 43 to 51 MHz "MUF" antenna (above) to drive a 5 pole band pass filter and hi level preamplifier and splitter which will become the "extra" input for several uses in near future. Design will appear under application notes.

3CX800 amplifier, homebrew, 1200 Watts (+60.8 dbm +/- 0.02 db) output at 1 dB output compression point (CW mode). Modifying a TL922A amplifier for "instant on" six meter amplifier.

90 feet of 7/8 inch hardline & 85 feet of 0.5 inch hardline to antenna feed point

[back to N6CA homepage](#)

Optimised Six-Metre Yagi

by Brian Beezley, K6STI, *Issue 39, October 1993*

Here's a design for a 5-element beam on a 23-foot boom with an unusual combination of performance characteristics. This Yagi comes within 0.2dB of the maximum gain possible on the boom length while keeping all back lobes 20dB down. This performance combination is very rare. The trick was to optimise the design over a narrow frequency range, 50.000 to 50.250MHz. Many 6-meter beams, both homebrew and commercial, are designed to work to 51 or even 52MHz. These designs invariably sacrifice forward gain and pattern quality for wide SWR bandwidth. When optimising a design over a narrow bandwidth, fewer elements are needed. As long as you have a certain minimum number, Yagi forward gain is determined by boom length, not element count. Elements added to the interior of this design won't increase its gain. (They may increase the bandwidth over which the pattern and SWR remain good, but this design adequately covers the low end of 6 meters.)

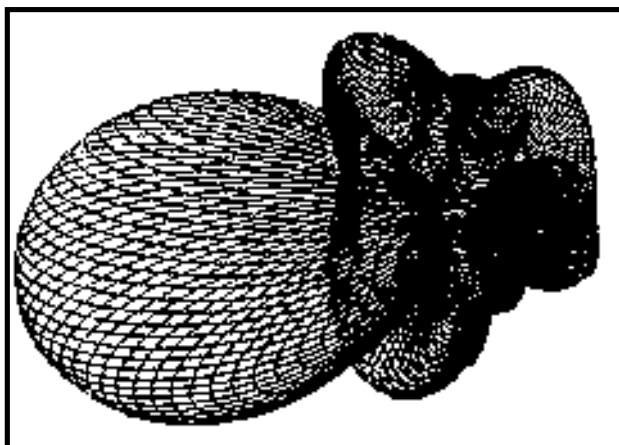

Figure 1 - 3D plot - Peak 10.26 dBd @ 50.110MHz

The free-space forward gain of this Yagi varies from 10.2 to 10.4dBd over 50.000 to 50.250MHz. These figures include conductivity losses of 0.08dB for 6061-T6 aluminium elements. When matched at 50.135MHz, SWR is less than 1.4 across the frequency range. The worst-case back lobe is 20dB down at 50.000, 21dB at 50.100, and

rises to 16 dB at 50.250MHz. This design was simultaneously optimised for maximum forward gain, minimum worst case back lobes, and adequate and impedance.

Conventional F/B was not optimised. This parameter takes the rear pattern into account at a single point.

The tuning of Yagi elements depends not only on their length but also on diameter, diameter tapering, and mounting method. These factors affect element self-impedance and thus alter antenna response. Thinner elements, tapered elements, conductive mounting brackets, and through-the-boom mounting shorten effective element length. Design dimensions are given for insulated, untapered, 0.375" diameter elements, for insulated, untapered, 0.5" diameter elements, and for elements with Cushcraft A50-6S tapering and mounting. If you use different elements or mounting methods, you'll need to adjust element lengths for optimum performance.

This design has a special property which makes it easy to adjust element tuning experimentally. The azimuth pattern has three back lobes which are equal in amplitude

only at 50.100 MHz. Since rear-lobe amplitude changes rapidly with frequency, you can easily verify that your antenna is correctly tuned. If the rear lobe is larger than the other two back lobes, the effective length of your elements is too long. If smaller, your elements are too short. You can use this simple test to obtain correct electrical behaviour for any physical element mounted by any method. When adjusting parasitic-element lengths, make equal changes to all parasitics. The input impedance of this design is about 12.5 Ohms. You can use any matching method as long as you observe the fundamental rule of Yagi matching: Never alter parasitic-element lengths or spacings of an optimized design to get a good match. Driven-element length has virtually no effect on gain or pattern, so you're free to adjust this dimension when matching. Don't alter element spacing. Change parasitic-element lengths only to move the equal-back lobe frequency to 50.100 MHz.

Figure 2 - Polar Plots @

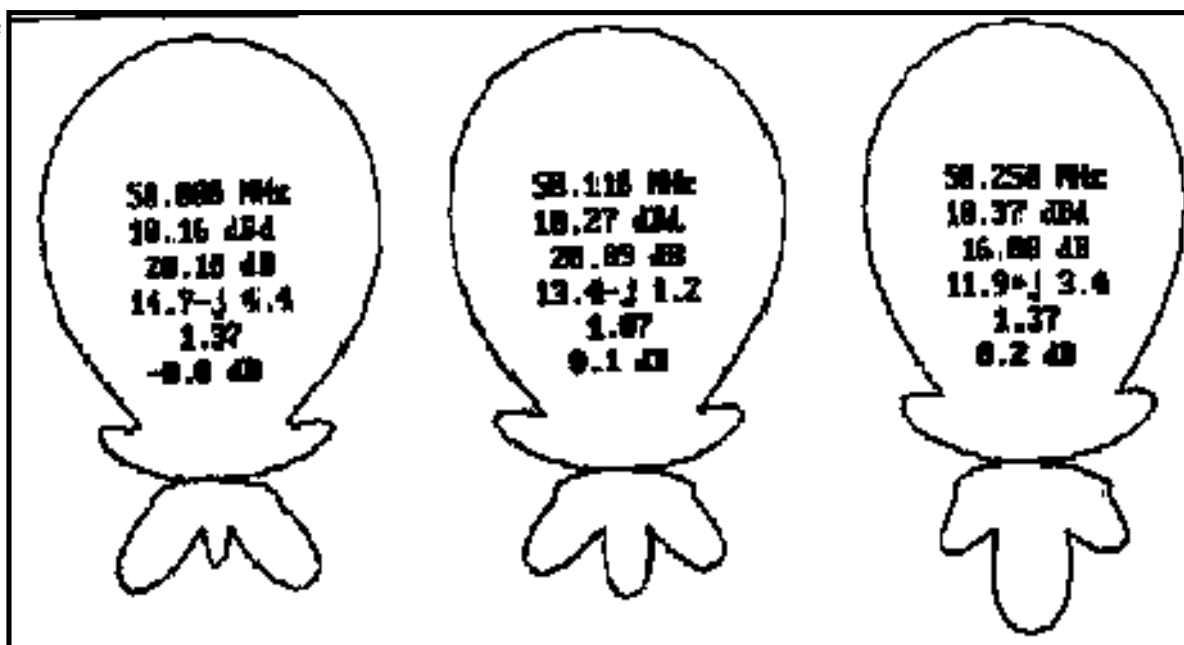

50.088, 50.110, and 50.250MHz

When I built this antenna in 1989, I gamma-matched it. However, I wouldn't do this with the knowledge I have today. A gamma match can induce current on the shield of a coaxial feed line. It can also induce current in the boom unless the driven element is insulated. These stray currents can reduce forward gain and degrade the pattern. You may be lucky as I was and get away with gamma matching, but why take a chance? Use a hairpin, T-match, or folded dipole and a good balun. The 12.5 Ohm input impedance transforms to a feed impedance of 50 Ohms for an equal diameter folded dipole. You can feed the folded dipole directly with 50 Ohm coax if you use a current type balun. You can make one by slipping ferrite beads over the coax or you can simply coil the coax into a few turns near the feed point. This design was developed in 1989 but was not published for some time. A carefully constructed, untapered, insulated-element version of this design came out 220KHz low. (I had to DF cordless phones below the 6-meter band to find the equal-back lobe spot!) I thought that perhaps some obscure environmental factor was responsible for the discrepancy (like the conductivity or dielectric constant of my composition roof). In typical ham fashion, I simply cut a quarter inch off each element tip and used the beam

successfully. But the 220-KHz anomaly continued to bother me. It wasn't until I began to use the sophisticated Numerical Electromagnetics Code (NEC) that I finally understood what was going on. NEC predicted that the antenna would perform as originally measured. The MININEC-calibrated algorithm I used to optimise this design had a built-in frequency offset! I immediately recalibrated all of my antenna-design programs to NEC. I subsequently found references to the MININEC frequency offset in the professional literature. If you optimise this Yagi for maximum forward gain without regard to pattern, impedance, bandwidth, construction tolerances, or reason, you can squeeze 0.2dB more out of the design. However, the back lobe degrades to just 11dB down and input impedance nose-dives below 5 Ohms. You say that you can match anything? That you never leave 50.110? That you don't experience rear-signal QRM on 6 meters, and that you want all the gain you can possibly get? What about those damn power leaks that always seem to start up from every direction whenever the band opens? What about the 3CO DXpedition which shows up on 50.300 and gets chased off the island before you're done retweaking your match up on the tower? If you're greedy about Yagi forward gain, you'll live to regret it.

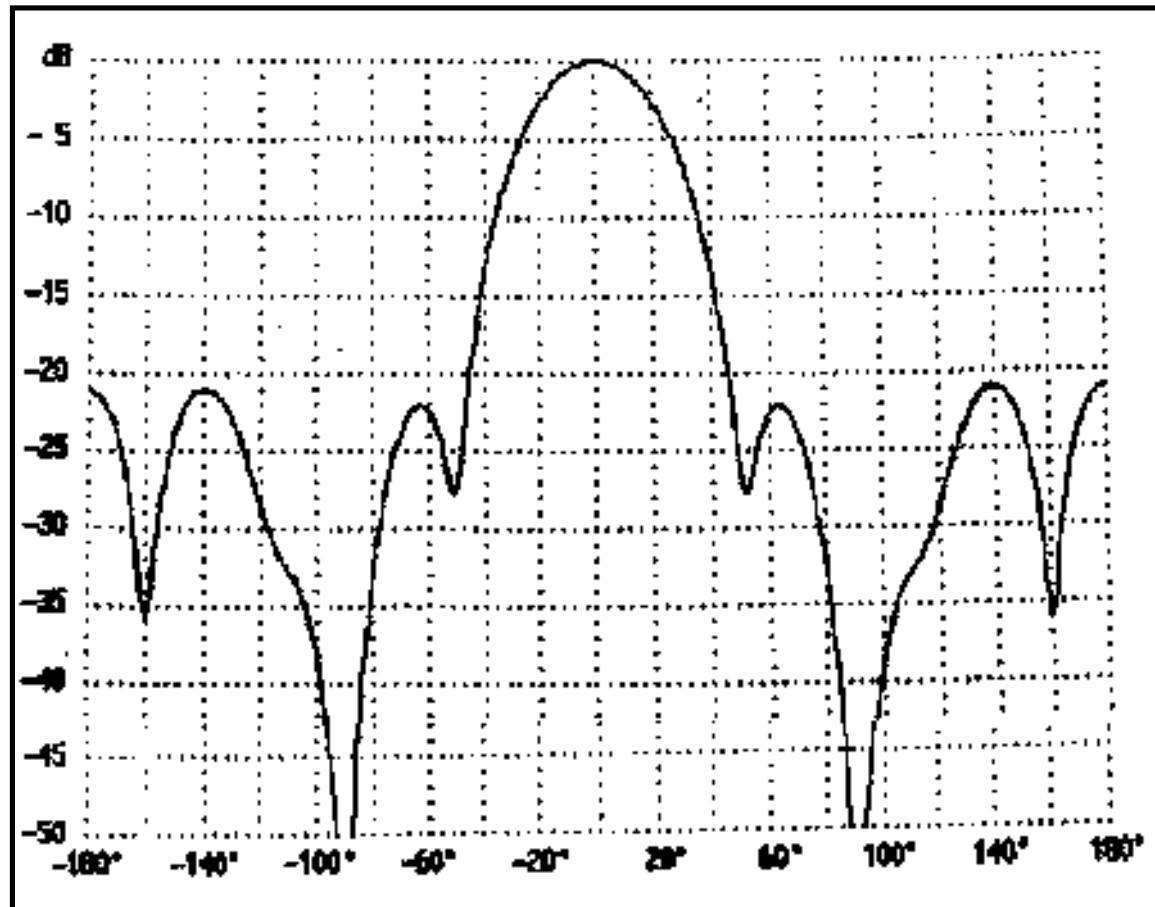

Figure 3 - Polar Plot - 50.110. 0dB = 10.26dBd

You can stack two of these Yagis for more gain. An H-plane stacking distance of 27

feet provides 3.1dB additional gain in free space. (Other stacking distances shift the equal-back lobe frequency away from 50.100MHz and require element readjustments. However, unless the array is very high, you won't come close to free-space stacking gain in practice. The elevation patterns of Yagis at different heights don't combine favourably. For example, adding a second Yagi 27 feet below one at 50 feet improves gain less than 1.2 dB at elevation angles below 5 degrees. E-plane stacking is an attractive alternative. If

you space the booms 29 feet horizontally, you'll get 3.0dB gain over a single Yagi regardless of height. The 3-dB beam width will be 9 degrees, with deep nulls at 20 degrees and side lobes 9.4 dB down at 31 degrees. Before you go to the trouble of E-plane stacking, think carefully about the operational inconvenience of such a narrow main lobe. The cross boom must be non-conducting near the Yagis. If you'll settle for an improvement of 2.6dB, the 8-element Yagi listed below is much more manageable than a side-by-side pair of 5-element designs. To give you idea of how this Yagi compares with other designs, tables 1 and 2 show some NEC results at 50.110 MHz:

**Figure 4 -
Polar Plot -
50.110MHz**

A50-5S, A50-6S, and 617-6B are wide-band Cushcraft designs. 6M2WL and 6M2.5WL are M2 Enterprises designs. NBS-5 and NBS-6 are National Bureau of Standards designs empirically optimised for

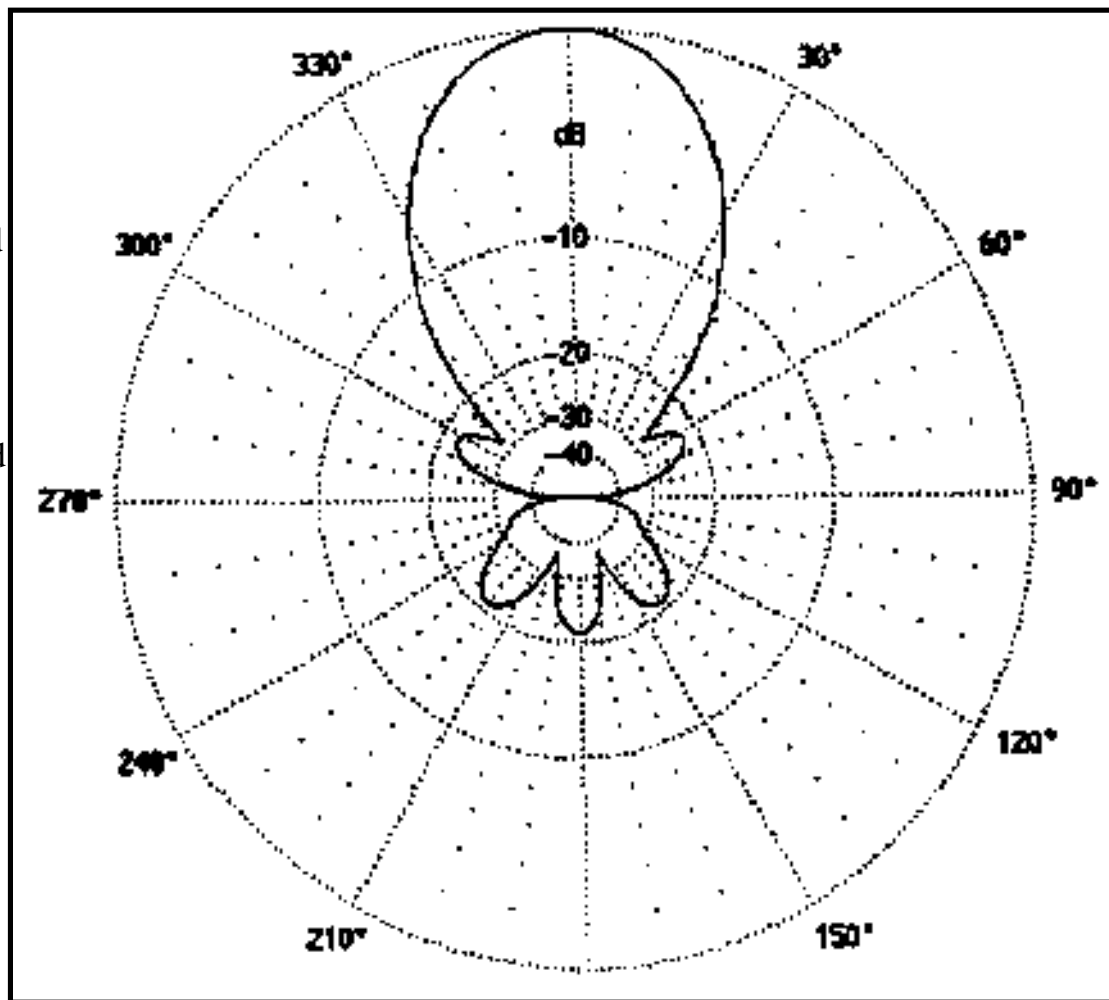

maximum forward gain. Five is the subject of this article, while Four, Six, Seven, and Eight are other computer optimised, narrow-band designs. Gain figure-of-merit is antenna gain minus maximum practical gain (maximum gain for the boom-length with reasonable input impedance and bandwidth, a definition which is vague but which can be evaluated mathematically as a function of boom length). As N6ND says, for a really good signal you need dBs in the air and dBs on the desk. This simple Yagi design will take care of airborne dBs. Desktop dBs are a matter between you, your licensing authority, and your spirit of adventure.

Element Positions and half lengths for Optimised 5-element Yagi (inches)

| Position | E1- #1 | E1- #2 | E1- #3 |
|-----------------|-------------------|-------------------|-------------------|
| 0.00 | 57.54 | 57.42 | 58.43 |
| 44.06 | 54.85 | 54.59 | 55.39 |
| 107.89 | 53.48 | 53.16 | 53.88 |
| 194.86 | 52.59 | 52.23 | 52.89 |
| 270.62 | 52.59 | 52.24 | 52.90 |

Element Positions and Half-Lengths For Optimized 5-Element Yagi

E1 #1: 0.375" diameter, non-conductive mounting bracket

E1 #2: 0.5" diameter, non-conductive mounting bracket.

E1 #3: Cushcraft A50-6S element mount 24" half-length of 0.75" diam., 0.625" diam. tips, U-bolt mount

Half-lengths are lengths measured from the centre of the boom to the element tip.



[To return to the archive page click here](#)

[Home](#) -> [Antennas](#) -> [Six-Meters](#)[Wire-Yagi](#) [More-Yagis](#) [LPDA](#) [Six-Meters](#)

SIX METERS

ARRL ANTENNA Vol 5 COMPENDIUM contains an article I wrote providing details about two portable 6 meters antennas I developed, a two-element quad and a three-element yagi with telescoping elements.

Both antennas were designed for easy construction and quick assembly and disassembly. The quad provides a measured gain of 4.2 dB over a dipole and the yagi 5.8 dB over a dipole. Details are given describing the methods used to measure the gain of both antennas.

Here is a photo of the 2 element quad taken when camping by the ocean. I am looking for new grids.



The following picture was taken on a beautiful summer evening while operating portable. The 6 meter portable yagi with collapable elements is clearly visible against the evening sky.



I have scanned a copy of [the article "Two Portable 6-Meter Antennas" here](#) Reprinted with the permission of the ARRL. Copywrite ARRL. All rights reserved.

ARRL ANTENNA Vol 5 COMPENDIUM is still available (January 2003) from ARRL (208 pages. First edition, © 1996-99, The American Radio Relay League, Inc. (ISBN: 0-87259-562-5) #5625 -- \$20.00 USD:

- <http://www.arrl.org/catalog>

[Back to Amateur Radio notes](#)

Copper Cactus Dual-Band Super J-Pole Antenna Project

Your going to like this super J-pole project, This home made j-pole is easy to build and sturdy, While looking for an jpole antenna project to build I remembered seeing a Marine antenna called the Super J-Pole in the 1988 ARRL Antenna Handbook, which claimed a 6 db gain over a quarter wave ground plane. I didn't have a machine shop at my disposal to fabricate the parts shown in the Marine antenna article so I set about redesigning the antenna using materials that were easy to find and work with. I have had very good results working with copper J-Poles, so I built my refined version of the classic J-Pole. I then added a short insulated section, the extra half wave of vertical length, and the needed half-wave matching stub.

Here is a schematic drawing of the home brew J-pole ([Click Here](#)) Word doc

Materials

Put the Heat to it

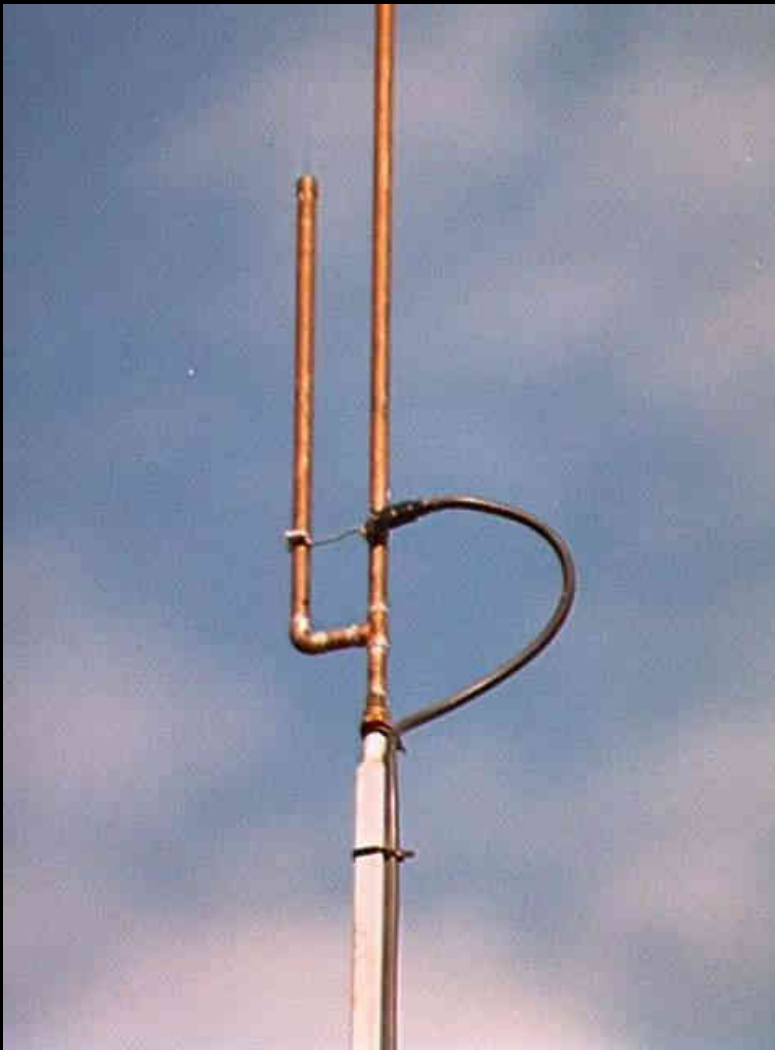

Now fire up the torch and start the assembly process from the bottom. See Figure 1. Use flux on all joints, solder the 1/2" threaded fitting to the mounting stub, and solder the 1/2" Tee fitting. Then proceed with the 57-1/2" section, 2" cross piece, and 19" section. Pay close attention to getting the 19" piece parallel to the 57-1/2" piece. After these have cooled, drill through both the 57-1/2" section of the 1/2" tubing and the hardwood dowel about 1/4" from the top end of the 1/2" tubing, and the bottom of the 38" section of the tubing. (See Photo A.) Then insert the 1/4" tubing to the 1/2" tubing and sweat solder the end caps. After these have cooled, clean the entire antenna, bend the half wave matching section to a half circle of about 4" radius around the antenna to help the balance and match.

All the materials except the S0239 fitting can be found at any good hardware store, and the whole antenna can be made in less than an hour.

In my design I use 1/2" copper schedule M tubing and 1/4" soft copper tubing. I had experimented with using Teflon insulator, but have since changed my design to use a 9" length of hardwood dowel with three coats of lacquer as the insulator, for more strength.



Clean all the tubing, and then from the 1/2" tubing cut one piece each of the following lengths: 57-1/2"; 38"; 19"; 2", and a piece about 3" long for a stub to mount the antenna. In addition to the tubing, buy a 1/2" elbow, a 1/2" Tee, two 1/2" end caps a 1/2" threaded fitting, and a cast iron floor flange for mounting. Get a piece of 3/16" or 1/4" soft copper

tubing 42" long. Find the center of the 1/4" tubing and bend it around a 1"-to-1-1/4" diameter water pipe or dowel.

Simplify the Feed Point of the J-pole



The feed point also needed to be made simpler, so I elongated one of the mounting holes of a panel mount SO-239 fitting and inserted a stainless steel adjustable band clamp. This goes on the 57 1/2" long section of 1/2" tubing. A short 2-3/4" length of # 14 copper stranded wire is soldered to the center terminal to go over to the 19" section. I used another stainless clamp to attach this. (See Photo B.) While experimenting to find the proper feed point, I found that the distance above the crossbar should be about 3".

Part's List

- 1 10-foot section of schedule M 1/2" copper tubing
- 1 1/2" copper elbow
- 1/2" copper Tee fitting
- 2 1/2" copper end caps
- 1/2" copper threaded fitting (for mounting)

Building Suggestions

1. You may use a Fiberglas rod as an insulator, but you will have to be very careful with the torch or you may weaken or burn the rod, or make it brittle.
2. When cutting the 1/2" copper tubing, cut the 57-1/2" piece from one end of the 10" length, and the 38" piece from the other end. By doing this you will have factory-cut edges for inserting the 1/2" dowel.
3. Be sure to keep the flame of the torch away from the insulator to avoid burning it.
4. Use paste flux on all joints when fitting the pieces together. Use enough flux, since you will be cleaning the entire antenna with solvent after assembly.
5. Use a weight to hold the 19", 57-1/2", and 2" pieces, and the Tee and the elbow, flat when they are sweat soldered together.
6. Use a ruler or caliper to check the spacing between the 19" and 57-1/2" pieces, to keep them parallel to each other.
7. When drilling the SO-239 fitting, use the drill press. Be careful not to drill into the threads of the fitting. After the holes are drilled, file the opening flat for a better band

- 1 1/2" cast floor flange (for mounting)
- 1 Piece of 3/16" or 1/4" soft copper tubing 42" long
- 1 Piece of 1/2" hardwood dowel of Fiberglas rod
- 1 SO-239 panel mount coaxial fitting
- 1 Piece of # 14 stranded copper wire
- 2 3/8" by 7/8" stainless band clamps

Tools needed:

- Tape measure
- Tubing cutter
- Propane torch
- Solder and flux
- Electrical tape
- Caulking compound
- Screwdriver
- A weight to keep parts aligned while soldering
- Steel wool or a Scotch Brite pad (for cleaning all copper)
- Spray can of clear exterior lacquer (to finish-coat completed antenna)

clamp fit.

8. After the best match has been found, you may want to solder the SO-239 and the stranded wire end to the 1/2" tubing.

9. When the antenna has been cleaned and matched, spray the entire antenna with a coat or two of clear lacquer to keep it looking nice.

10. After everything else has been done, apply silicon or a butyl rubber compound to the insulating section, then cover the joint with electrician's tape for a weather tight seal.

11. A 1/2" pipe coupling and a length of pipe may be used in place of floor flange for mounting in a roof tripod.

Suggestion by KB9TIO

An Improved(?) feed arrangement is to use copper couplings, same size as the tubing. Split the coupling lengthwise, bend out @ 1/4" and notch for the so-239 inner ring. attach with sheet metal screws an/or solder so-239 to coupling. repeat with 2nd coupling and solder other end of #14 wire to flat on coupling. this provides a strong joint and very easy tuning by sliding the couplings up or down the tubing as needed. this tip was given to me by Tom-KB9OZZ

Thanks, Matt KB9TIO

Suggestion by **KD7GQC**

I have also seen variations on the J Pole which omit the insulator section. In the first, the center conductor is soldered directly to the driver element, and the entire antenna is thus at DC ground. The second variation is also an all-copper design, but you capacitively couple the RF to the element, by wrapping several turns of insulated wire from the center conductor around the driver section of the J pole. I can't vouch for the second approach, but the first seems to work great, for installations where a DC "short to earth" is not a problem. It seems to me that eliminating the insulator section makes for a simpler, and potentially stronger, design. Kudos on a great antenna! 73s, Brian KD7GQC

One last suggestion: put a piece of steel about 1/2 or 3/8 of about a foot and a half up the center of it (from the base) this will strength the bottom portion of the pole.. put a small curve in it so it touches the inner wall of the pipe.. my parents use this j-pole and live in a windy area.. and this fixed that problem.

In order for these instructions to work great.. Please send me feedback on if you had problems and what can be done to help the next ham.. I don't get much feedback on the copper cactus J-pole, Guess that's good in a way, but would love to either way [Praise or Suggestions](#) about this project.

[Recommend This J-Pole to a Friend](#)

[Back to Amateur Radio notes](#)

NamesCentral.com

The only Banner Exchange that gives you 5,000 impression to join and a 75% exchange ratio!



NamesCentral.com



5,000 Free Impressions

[\[Feedback\]](#) [\[Site Map\]](#) [\[Search\]](#) [\[About this site\]](#)

Best sites 

QHtenna by N4QH

Click on the banner



© Lowell Enterprises

2M TECH LIST

MOD-----TECH-----FILES NEEDED

SEND VIA EMAIL TO: sixclub@6mt.com

© Lowell Enterprises

VHF/UHF MESSAGE BOARD

HEATHKIT

FINAL TUNING KNOB FOR THE HEATH SIXER AND TWOER (QST 1-67) [f46.zip](#)
MODIFYING THE HEATH HW-30 TOWER (HORIZONS 12-62) [c6.zip](#)

© Lowell Enterprises

HENRY

HENRY MANUAL AND SCHEMATIC FOR THE 2002A, 2004A, 2006A [henry.zip](#)

ICOM

IC 202 AMP (73 9-80) [f35.zip](#)
IC706 RECEIVE MOD .05-165MHZ (N1IST) [ics.zip](#)

JOHNSON

© Lowell Enterprises

VIKING 6 AND 2 (COMPLETE MANUAL AND SCHEMATIC) --[vik62.zip](#)
ASSEMBLY INSTRUCTIONS FOR THE VIKING 6 AND 2 (PLEASE READ THE PAGES A-G FIRST) [62assembl.zip](#)

SWAN

SWAN MULTI DRIVE 2MT ANTENNA (QST 10-69) [swt.zip](#)

YEASU

EXTENDED COVERAGE OF THE 2MT FT736R (VE6XT) [exc.zip](#)
UPDATE YOUR FT221R (QST 1-79) [ftto.zip](#)

© Lowell Enterprises

ACCESSORIES

"AM - 33" CONVERSION FOR 6 AND 2 [c14.zip](#)
A TUBELESS VFO FOR 6 AND 2 (73 8-66) [f39.zip](#)
2MT BEACON (73 2-80) [f37.zip](#)
A RUGGED, COMPACT ATTENUATOR (QST 5-98) [attenu.zip](#)
144MHZ TVI FILTERS (QST 8-80) [tmtvi.zip](#)
A SOLID STATE SANDWICH FOR VHF 6 AND 2 (QST 10-69) [sss.zip](#)
TRANSISTOR FOR 432 AND 2MT PREAMP (QST 2-66) [sis.zip](#)

AMPLIFIERS

UTILIZING THE 826 (AMP FOR 10, 6 AND 2) (QST 5-50) [826.zip](#)
LINEAR AMP W8HHS (VHFER 1-65) [c2.zip](#)
2- 4CX250B ON 2MT (HORIZONS 12-62) [c5.zip](#)
AMP USING A 3CX800A7 (QST 4-84) [tmtcx.zip](#)
KILOWATT FOR 6 AND 2 USING 3 4CX250R (QST 2-64) [kfst.zip](#)
2MT KILOWATT RF DECK USING 2 4CX300A (QST 2-60) [myn.zip](#)
100 WATTS ON 2MT (73 2-67) [ohw.zip](#)
25 WATT LINEAR AMP 2MT AND 220 (QST 8-88) [tear.zip](#)
VHF AMP DESIGN (QST 9-79) [vhfd.zip](#)

ANTENNAS AND ACCESSORIES

3 ELE DELTA LOOP (QST 4-69) [f48.zip](#)
5 ELE FOR 2MT (HORIZONS 8-62) [c12.zip](#)
6 ELE FOR 2MT (HORIZONS 4-63) [c8.zip](#)
THE BIG WHEEL ON 2MT (QST 9-61) [4.zip](#)
PERFORMANCE TESTS ON THE BIG WHEEL 2MT ARRAY (QST 10-61) [5.zip](#)
A 2 BAND HALO FOR 6 AND 2 (QST) [1.zip](#)
A COMPACT HYBRID ANTENNA FOR 2, 432, AND 23CM [as.zip](#)
A PORTABLE QUAD FOR 2MT (QST 9-80) [pquad.zip](#)
LAZY "H" COLLINEAR ARRAY (QST12-81) [lzys.zip](#)
A 3 ELEMENT 2MT BEAM (73 5-80) [tepbm.zip](#)
2MT 7 ELE CUBICAL QUAD BY GW4CQT [7quad.zip](#)
MODIFIED W5UN QUAGI DESIGN [wfun.zip](#)
BIG WHEEL FOR 2MT (CLOVERLEAF ANTENNA) [bwel.zip](#)
COPPER CACTUS ANTENNA (K6OZP) [ccjp.zip](#)
STACKED HALOS FOR 6 AND 2 (QST 8-64) [sh.zip](#)
QUAD FOR 6 AND 2 (QST 2-63) [qd.zip](#)

- SIMPLE 2MT HALO (QST 8-57) [stm.zip](#)**
- LONG PERIODIC 140-450MHZ (QST 6-63) [lp.zip](#)**
- 2MT RHOMBIC (QST 4-67) [rhom.zip](#)**
- 2MT HALO (QST 8-57) [thlo.zip](#)**
- A DOPPLE-QUAD ANTENNA (QST 2-85) [dqa.zip](#)**
- DESIGNING A 2MT PORTABLE YAGI (QST 6-85) [tmpy.zip](#)**
- A ROPE LADDER 2MT QUAGI (QST 3-95) [laddr.zip](#)**
- A 5 ELE QUAD FOR 2MT (QST 1-95) [tqd.zip](#)**
- "J" DRIVEN 2MT BEAM ANTENNA (QST 11-79) [tmjpl.zip](#)**
- 2MT PORTABLE QUAD (QST 6-81) [pqu.zip](#)**
- 2 ELE ANTENNA FOR 2MT (QST 10-79) [tean.zip](#)**
- 2MT "J" ANTENNA (QST 4-77) [tmja.zip](#)**
- LONG PERIODIC 2-432MHZ [lpmb.zip](#)**
- 8 ELE 2MT YAGI [eltm.zip](#)**
- 8 ELE 6MT --- 4, 7 AND 8 ELE 2MT ANTENNA (WB7PMP) [pmp.zip](#)**

CONVERTERS

- 2MT CONVERTER (VHF 9-62) [f31.zip](#)**

PREAMPS

- FET PREAMP FOR 2MT AND 432 (73 7-67) [tfet.zip](#)**
- TRANSISTOR PREAMP FOR 6MT AND 144 (QST 11-62) [tpsa.zip](#)**

TRANSMITTER

- SSB 2MT TRANSMITTER (73 8-66) [f38.zip](#)**

[BACK TO HOMEPAGE](#)

Copyright © 2001 by Lowell Enterprises

Santa Clara County, California ARES/RACES

Emergency Antennas

- *300 TV Twin-lead J-Pole Antenna (Approximately 3 dB Gain)*

This is an easy antenna to make from existing or inexpensive materials. It rolls up for easy storage and can be deployed in seconds; just hang from the nearest ceiling or attach to the end of a fiberglass fishing pole or PVC pipe. Better than a rubber duck (what isn't?).

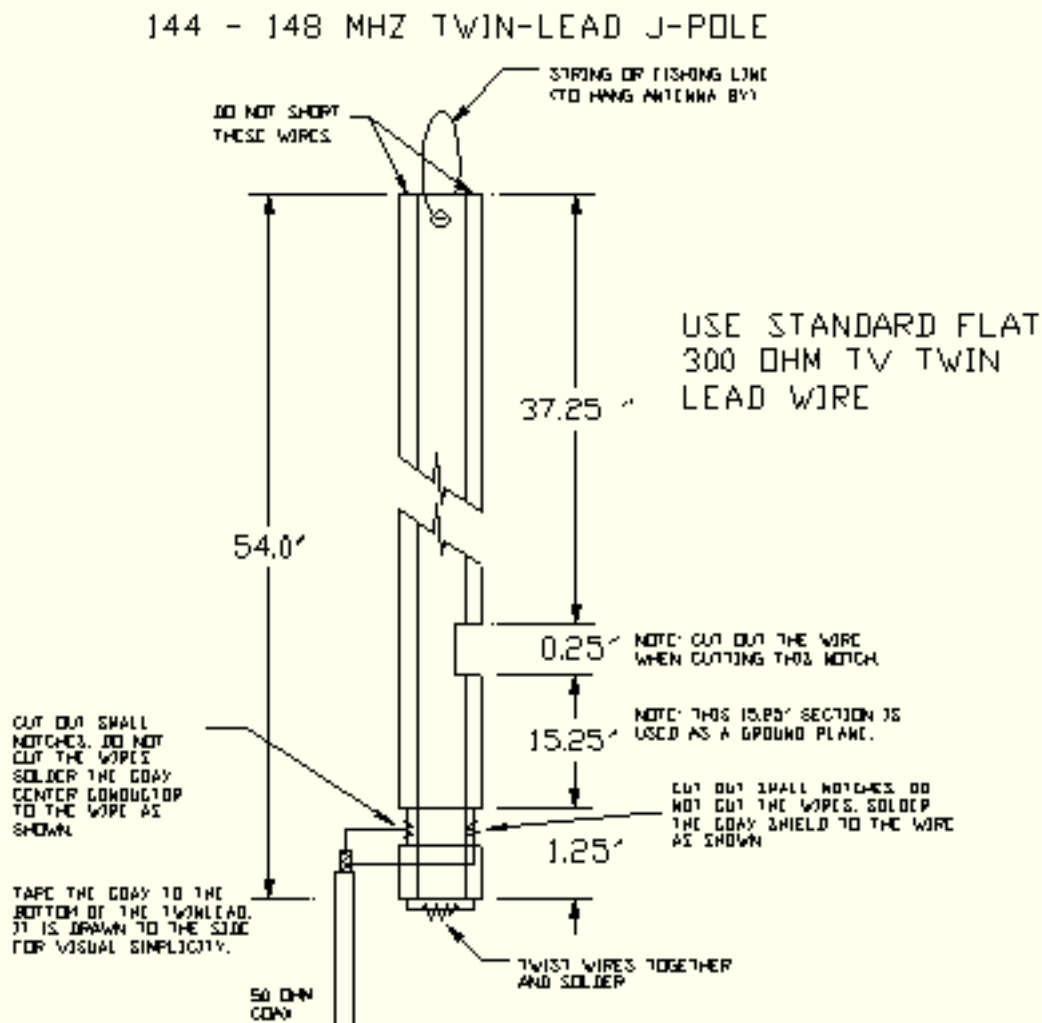

- *1/4 wave Mag Mount as a Portable Antenna*

If you need to operate portable and only have a mag mount antenna available, try placing any large piece of metal underneath it. This might be a refrigerator, stationary car, or a metal rain gutter. You might also try making your own portable ground plane by placing some aluminum foil over a large piece of cardboard (2 feet x 2 feet minimum).

- *American Legion J-Pole*

If you are able to operate fixed portable, try the "American Legion J-Pole". Attach it to the top of a 10 foot section of PVC pipe and mount this to a camera tripod. Attach weights to the legs for stability. This makes a very nice fixed station antenna.

To add your favorite antenna to the list, [contact the Webmaster](#)

[Web Site Home Page](#)

This page was last updated 04/20/02

Specifications for antenna at bottom of diagram

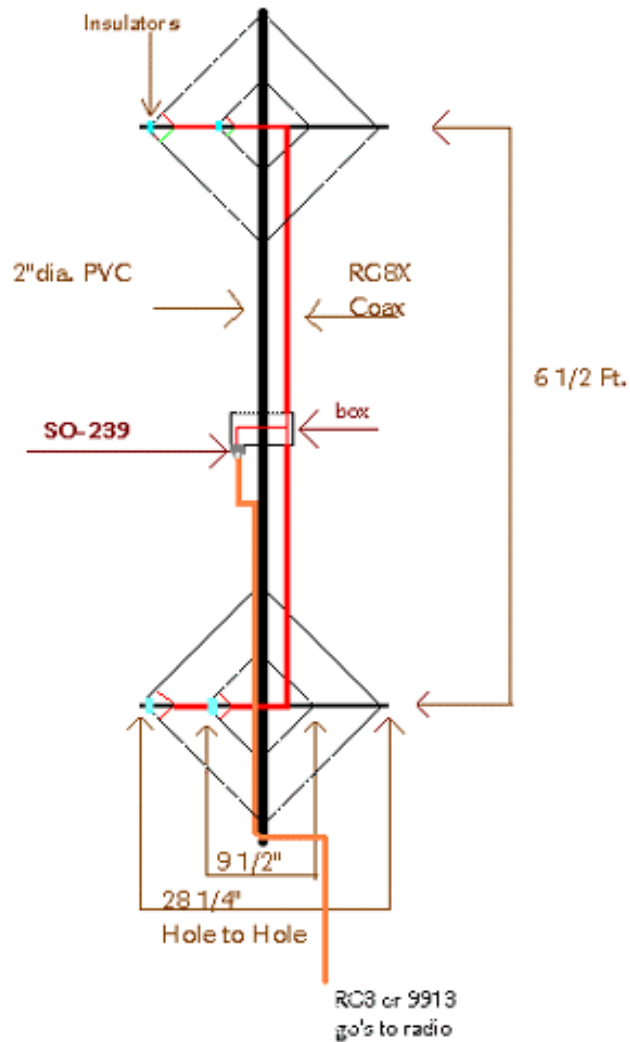

KE4UYP's Biquad

144/440 MHz

Specifications

This is a vertically polarized Broadside and Collinear Array each Loop is a vertically polarized Broadside Array both the right and the left side of the Loop is a bent 1/2 wave dipole working 180 degrees out of phase with the other one and that gives you 4.15dbi of gain The two Loops are Stacked one above the other this makes a Collinear Array at one wavelength at 2m that gives you 5.15dbi of gain so the Total gain of the Antenna is 9.15dbi all this from four pieces of wire and some PVC pipe.

One of the easiest construction techniques for building this antenna is to use 3/8" fiberglass rods for the horizontal spreaders that pass straight through the two inch PVC pipe you can hold them in place with two nylon tie wraps one on each side of the two inch PVC pipe pulled tight around the

fiberglass rod.

You can make insulators from half-inch diameter PVC pipe 3 inches long. Drill a 3/8" hole 1 1/2" from one end of the pipe all the way through both sides of the pipe, then drill two 1/8" holes near the ends of the PVC pipe for the antenna element wire to go through. Then you can slide this pipe on to the fiberglass rod.

If you solder the coax connections then seal it with epoxy tape it will be 100 percent reliable and weather proof, also make sure you extended the two inch pipe twelve inches past one of the loops you can U bolt that part of the pipe to your mast, of course this would be for FM operation. See attached drawing.

This is an inherently broadband antenna so fine-tuning the elements is not necessary the reason why these elements are shorter than a standard element is because when you connect two driven elements in parallel with each other this creates an excessive amount of inductive reactance and the easiest way to remove this is to simply make each element shorter normally these elements would be three inches longer on 2 meters.

The impedance of one loop is 100 ohms so when you put the two loops in parallel you get 50 ohms this makes a perfect match for coax cable. If you are using this for 2 meter SSB then of course you need horizontal polarity and the loops would be side-by-side this puts the feed points at the bottom corners of each loop. the antenna would then be mounted on the mast from the center.

The formula for calculating the overall loop lengths is 11665.4 divided by $xxx.xx$ Mhz's the answer will be in inches.

[Back to home page](#)



The Simple Collinear



Wherever there is a need for a vertically polarized omni-directional antenna with gain, a collinear is used. The vertically polarized collinear takes the form of two or more half waves in-line and in-phase, resulting in an omni-directional pattern with maximum radiation near the horizon. The techniques used to ensure that the half waves are in phase are:

1. Interspersing the in-phase half waves with quarter wave stubs. This is the method described in the ARRL Antenna Book.
2. Making the antenna out of half wavelengths of coax with the outside of the coax used as the radiating elements and the inside of the coax used as the phasing elements.
3. Interspersing the half waves with resonators to provide the necessary phase reversal.

Each of these techniques is designed to reduce or prevent radiation from the out-of-phase components of the antenna. The Simple Collinear uses a different technique.

The Simple Collinear makes use of the fact that large diameter elements within an antenna can radiate more readily than small diameter elements. Therefore if the large diameter elements are in phase and the small diameter elements are in phase but out of phase with the large diameter elements, radiation from the large diameter elements dominate.

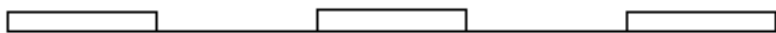

Shown above is a schematic of a 5 element collinear—3 large diameter elements and two small diameter elements. Each element is about $\frac{1}{2}$ wavelength long, and since the phase switches every half wavelength, the 3 large diameter elements are in phase and the 2 small diameter elements are in the opposite phase. The result is an antenna with about 2 dB less gain than if all the elements are in phase. Simulations show that this can be applied to very large arrays. A 45 element array (23 large diameter and 22 small diameter elements) is simulated to have 14.38 dBi gain.

| Performance vs Number of Elements | | | |
|--|-------------------|-----------------|-------------------|
| # of Elements | Gain (dBi) | Z (ohms) | Ideal Gain |
| 1 | 2.06 | 79 + j14 | 2.06 |
| 3 | 3.76 | 103 + j7 | 5.41 |
| 5 | 5.17 | 117 + j1 | 7.32 |
| 11 | 8.09 | 144 - j14 | 10.49 |
| 23 | 11.33 | 176 - j42 | 13.6 |
| 45 | 14.38 | 207 - j90 | 16.48 |

Large diameter elements = 1 inch.
 Length of large diameter elements = 38.15 inches.
 Small diameter elements = 0.040 inch.
 Length of small diameter elements = 40.95 inches.

Ideal Gain assumes all elements have
 1 inch diameter and are fed in the center.

The table above shows the gain and impedance of a 2 meter 45 element antenna, consisting of 23 elements, 1 inch diameter and 38.15 inches long and 22 elements 0.040 inch diameter and 40.95 inches long. The antenna has its feed point the center of the lowest element, although it could be fed at the center of any of the 45 elements. Also shown in is the performance of various versions of the same antenna, varying the number of elements between 1 and 45. Note that the gain increases by 3 dB for each doubling of the number of elements. I stopped the simulation at 45 elements because I can't imagine building an antenna larger than this—at least at this time. Also shown in this table is the simulated gain of an ideal antenna assuming all 45 elements have 1 inch diameters and are fed in phase with voltage sources. Note that gain is only about 2 dB higher than the simulated real antenna. This is because the in phase currents are distributed quite uniformly across the antenna, an effect achieved by adjusting the lengths of the elements slightly from half wavelength. The 0.040 diameter is a compromise between making the diameter small to reduce the radiation, but not so small that ohmic losses become important. The 45 element array is simulated to have only 0.1 dB loss due to ohmic loss in the 0.040 diameter copper elements. All these values were determined using K6STI's AO Antenna Optimizer MININEC program.

A 5 element test antenna was simulated and built. It was optimized for 5 elements and not created from a reduction of the 45 element array in the table; its gain was simulated to be 5.7 dBi and impedance about 100 ohms at 147 MHz. The small diameter elements were simulated to be 0.015 inch because for a small array, radiation from these elements is more of a factor and ohmic loss is less of a factor. All elements were 38 inches long. The 1 inch elements were made from aluminum, but any metal will have negligible loss—copper, aluminum, galvanized, or steel are all ok. The small diameter elements should be 0.010 to 0.020 inch in diameter (#30 to #24). There will be a slight reduction of gain if #24 wire is used. I used #26. Support of the antenna in the small diameter sections was provided by 3/4 inch diameter schedule 40 PVC pipe. Guying was provided by 3/16 inch polyester cord. The antenna was fed through a quarter wave transformer made from RG59U. A few ferrite beads on the RG59U provide any needed current balun action. The antenna was installed on the roof in place of an old TV antenna. Simulated and measured SWR, with measurements taken at the end of the transformer, are shown.

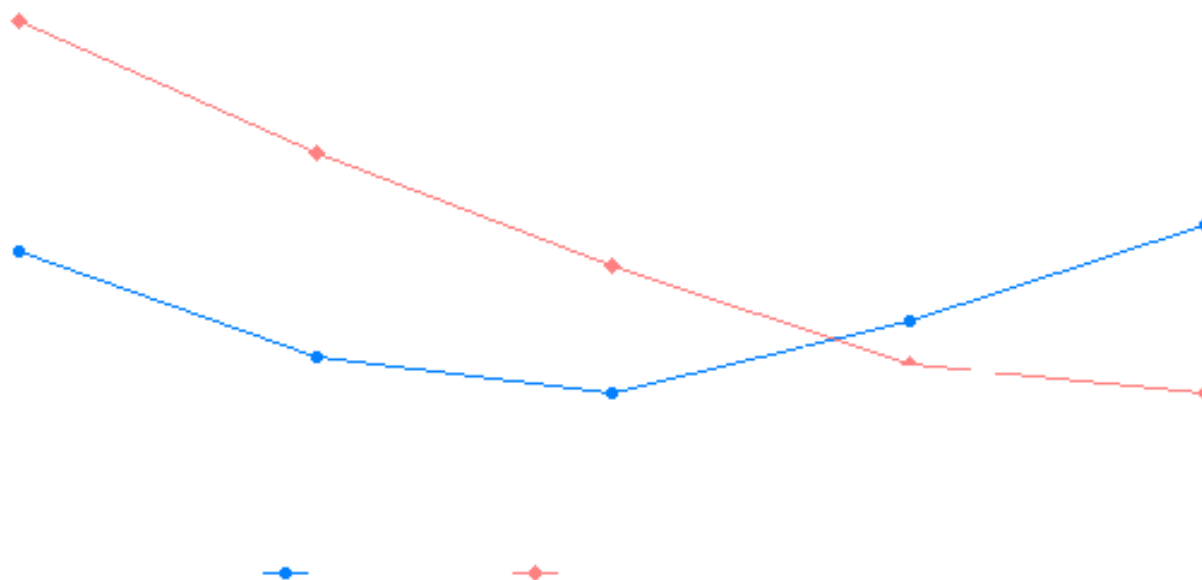

This antenna has many attributes. It is easy to model. It is easy and inexpensive to build. A high gain version can be built in-situ, adding a couple of elements at a time, adding guying as elements are added. It is broadband. Even the 45 element version is simulated to have an SWR less than 1.7 across the 2 meter band (144-148 MHz). Current distributes well over the entire antenna making the aperture efficiency high.

Here are some possible applications.

1. Small versions like the 5 element antenna described can be roof mounted for repeater access.
2. Versions of this antenna should be good for applications in the field such as for contesting or DXpeditions, giving good gain and good height cheaply.
3. This antenna would make a good base station antenna for 2 meter and higher repeaters. Down tilt can be designed in if desired by slightly shortening the elements.
4. It should be a good antenna for communicating via Tropospheric propagation.
5. Several could be put together to make a phased array.
6. It could be used as a feed for a cylindrical parabolic antenna. Large cylindrical parabolic antennas should be easier to make than large paraboloid (parabola of revolution) antennas.

Ross Anderson W1HBQ September 7, 2002

E-mail me at ross_anderson@comcast.net

Notes and References:

The ARRL Antenna Book, 19th Edition, pp 8-36—8-38.

Collis, “Omni-Gain Vertical Collinear for VHF and UHF” <http://www.repeater-builder.com/rbtip/wa6svt.html>

Oblivion and Kaboom, “A 2.4Ghz Low-Power 5dBi Vertical Collinear Antenna for 802.11 Applications”

http://www.guerrilla.net/reference/antennas/2ghz_collinear_omni_lowpwr/

Maxwell, "Some Aspects of the Balun Problem"

<http://home.iag.net/~w2du/Reflections2Chapter21SomeAspectsoftheBalunProblem.pdf>

The beads I used were FB-43-5622. http://www.amidon-inductive.com/associates_prod_largerbeads.htm

K6STI can be reached at bb at n2 dot net.

My homepage "Ross's Antennas" with links to my other pages. http://home.comcast.net/~ross_anderson

Keywords: The Simplest Collinear



Build a 2 Meter DDRR for Mobile

By W5GVE

This is a story of an antenna and its modification over time into "better" forms. Part of the improvement was by design, and part was just plain good luck. When you are working closely with an antenna, unless you keep very detailed records, it is difficult to discern which is

which after the fact.

PURPOSE

The original objective was to build an antenna for 2 meters FM (146-148 MHz), vertically polarized, and omni-directional. The world is already full of such antennas; why something new? The truth is that I needed a short antenna that wouldn't scrape against the low-hanging trees of the desert where shade is precious, or against the 7 1/2 foot ceiling of the multi-story parking garages in the cities I occasionally visit.

Many years ago, I was intrigued by the DDRR antenna. It originally was a quarter wavelength radiator sprouting up from a ground plane, taking a sharp turn to the horizontal and coming around in a circle to almost meet itself where it sprouted. Sort of an open loop parallel to the ground with one end connected to the ground. This obviously horizontal antenna behaved in an outrageous fashion—*it radiated vertically!* There's no free lunch however and, as originally described, it worked about half as well as a full-sized quarter wave vertical wire. But, if you could stand the tariff, it *was* low to the ground—1/10th as tall as the vertical.

I stood it as long as I could and finally built one for the Citizen's Band (27.5 MHz). This was years ago, and as I recall, the mobile CB-DDRR was three feet in diameter, six inches tall and looked like a pair of hula hoops. It was built of 1/2" aluminum cable-TV trunk cable held together at crucial points with automotive hose clamps. And, it worked! At least *until my wife saw it*, and said she could not be seen dead driving around town under it! So, DDRRing went dormant for a decade.

In subsequent years, more articles appeared on the DDRR in its quarter-wave version, and later, a half-wave model. I didn't try either and pretty well believed what I was reading. As the need for the 2M low profile antenna grew, my mind turned to the 1/4 wave DDRR, through the 1/2 wave DDRR and ended on the great idea of maybe a 3/4 wave DDRR!

A 3/4 wave edition would not be any taller than a plain vanilla (1/4 wave) DDRR, and would have much greater capture area. It seemed like the perfect solution. If it looks weird, so what? My wife has her

own car now. All systems were GO, so I began. Not having a whole lot of imagination, I began by resurrecting the concept of the CB-DDRR, 1/2" aluminum TV cable and all.

At 147 MHz, a wavelength is quite close to 80" and 3/4 wavelength is 60". The diameter of a 3/4 wavelength DDDR is 20". I arbitrarily decided that 3" in height (center to center) would probably be tall enough to help capture incoming wave fronts, and it *did* resemble the old CB version.

Figure 1

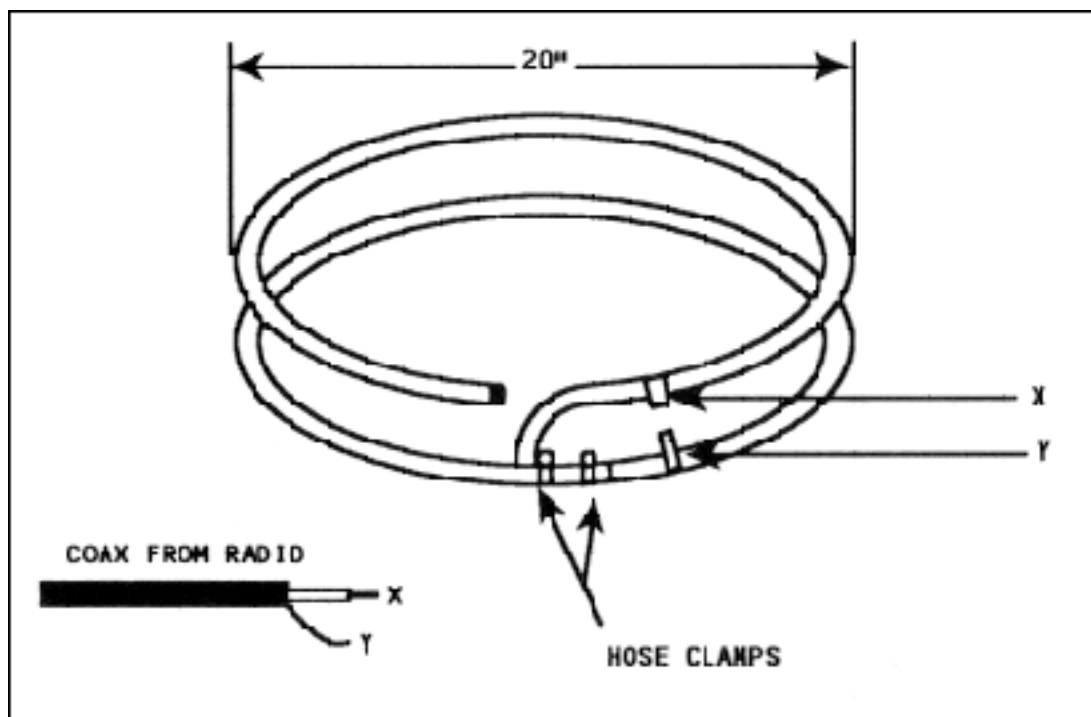

WORKED LIKE WOW!

For testing purposes, I taped it to the roof of my little Chevrolet station wagon. Wow, did it ever work! I compared it to the 5/8 wave vertical magnetic mount whip on the other end of the station wagon roof, and the 3/4 wave DDDR equaled or exceeded the commercial whip. One little problem. It had a great gain off one section of the antenna, average elsewhere, and a tiny area of a slight null. Further tests showed it had a substantial amount of horizontally polarized radiation in addition to the desired vertical radiation. What was going on? The Mark I version has problems!

DIRECTIVITY

I believe the 3/4 wave DDDR showed directional characteristics because its physical structure is about 1/4 wavelength in diameter. Current on exactly opposite points of the radiator's circumference are 3/8 wave (30") out of phase, electrically, but are 1/4 wave apart (20") physically. I did not have the means to work this out theoretically, but it seems reasonable that this physical configuration would simulate radiation patterns of discrete radiators phased and separated in this manner. I decided this was the kind of a problem that could not be overcome. It could be developed if, some day, I want to build a directional vertical low-height radiator. Maybe some day.

POLARIZATION

The method of feeding the antenna was the same as I used years ago on the CB-DDRR. Since the DDDR can be looked upon as a section of parallel conductor feedline, with one side joined to a ground plane, one end is effectively shorted and presumably at a very low impedance point, and the other end is at a very high impedance, it seemed reasonable that at some point near the low end there are a pair of points at 50 ohm—just right for direct coax feed. It worked on the CB-DDRR and I figured it would work on the 2M version too.

A straight transmission line antenna, laid out horizontally, would radiate horizontally polarized energy. But when the same antenna is curled up into a loop, about 1/2 wavelength in diameter, it radiates vertically polarized energy. In order to get a good match (50 ohms, with low reflected power) I had to skew the feed points slightly. That is, the center conductor of the coax was connected to the upper line at a point NOT directly over the point where the coax braid is connected.

TOO MUCH SKEW?

I believe the skewing of the feed points resulted in the mostly vertical, but partly horizontally polarized radiation. Again, this is an area for further eXperimentation, since I did not pursue it at this time. So much for the 3/4 wavelength DDDR.

Considering the phasing problem that gave me the unwanted directivity, I concluded that some of this could be expected with a 1/2 wavelength. So, I decided to do a plain old 1/4 wavelength DDDR, but by using some of the information about transmission line radiators I had picked up in the intervening years since the CB-DDRR, mainly the work of *Ted Hart, W5QJR*. The better the conductivity of the radiator, the better the antenna. That rules out aluminum tubing and hose clamps.

Figure 2

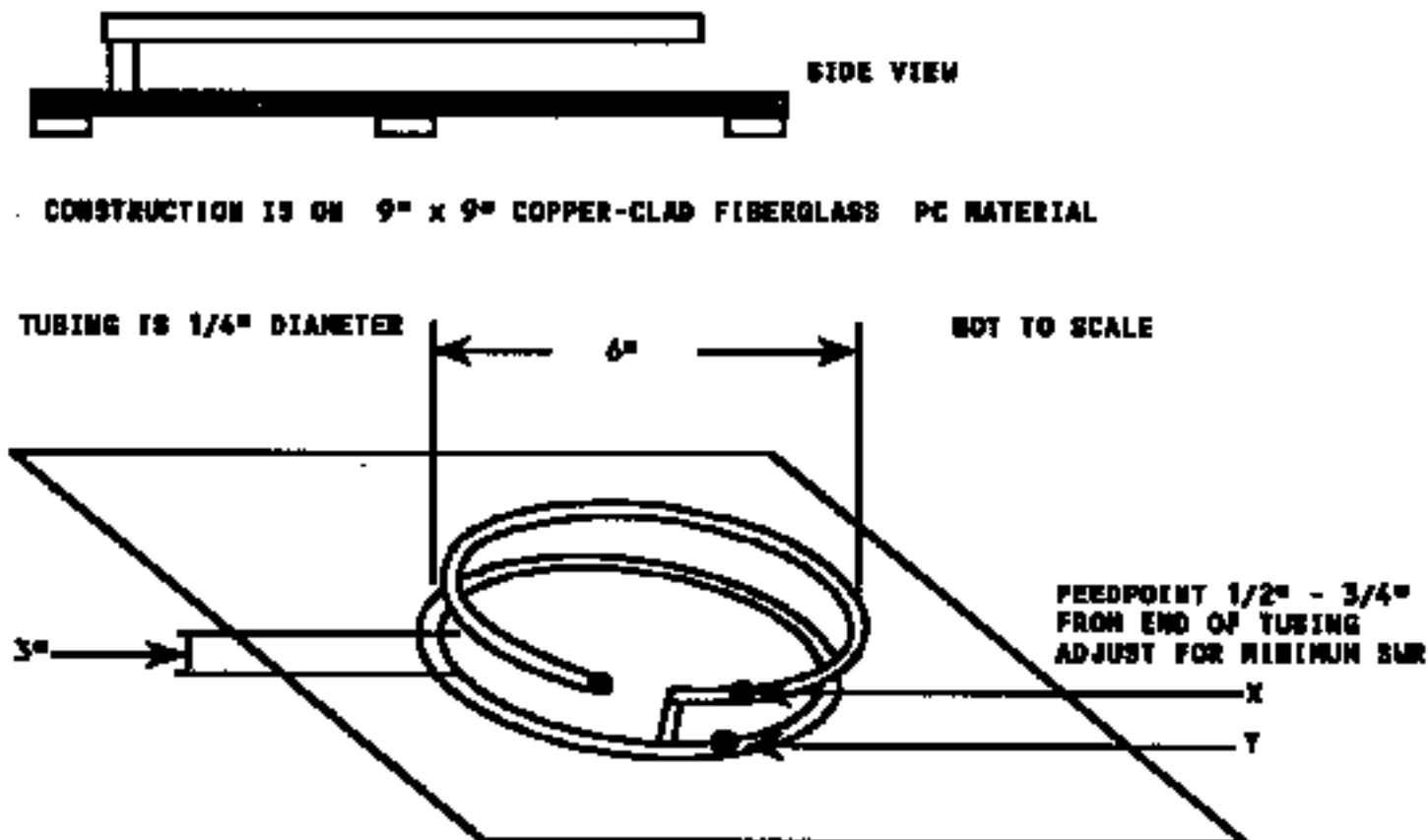

SOME SUCCESS

I decided to begin with a 1/4" diameter copper tubing, formed into two 6" diameter loops, separated 3". One loop is tack-soldered at 3" intervals to a 9" square of copper-clad fiberglass printed circuit board stock. The coax braid is soldered with no length to the circuit board. The center conductor is taken up 3" and soldered to the free loop about 2" from the shorted end. Matching is accomplished by three methods: adjustments of the tap on the free loop; trimming the free end of the loop (raising frequency of resonance); and bending the free end of the loop up or down (raising and lowering, respectively, the frequency of resonance). The results? Equal to the 5/8 mag-mounted vertical whip! The Mark II is a success. Now to improve on this!

THE NEXT VERSION

The Mark III version was also begun on a 9" square of circuit board material. It has great surface conductivity, is stiffer than solid sheet copper, can be soldered readily, and can be attached to a magnet for car-roof mounting. Instead of a double loop of 1/4" copper tubing, the Mark III uses a single 20" long loop of 5/8" copper tubing, a 5/8" copper "L", and a 2" piece of 5/8" tubing to space the loop over the ground plane. Matching is the same as the Mark II's, with the exception of soldering to the loop. I had to use a fancy homemade copper clamp-low resistance, moveable, and IT CAB be soldered!

Once the best tap point has been determined, drill a small hole at the point. Use a sheet metal screw and a copper tab to solder on the coax center connector. The adjustments for best match are limited to two: trimming the end of the loop with a tubing cutter and moving the feed tap. This is a high-Q device, and moving the feed tap has a very large influence on the resonant frequency, as well as feed point

impedance. Performance? Equals or exceeds the 5/8 wave vertical whip in all respects. Being fairly high Q, it has a useful bandwidth, a little narrower than the whip—about 2 1/2 MHz.

Figure 3

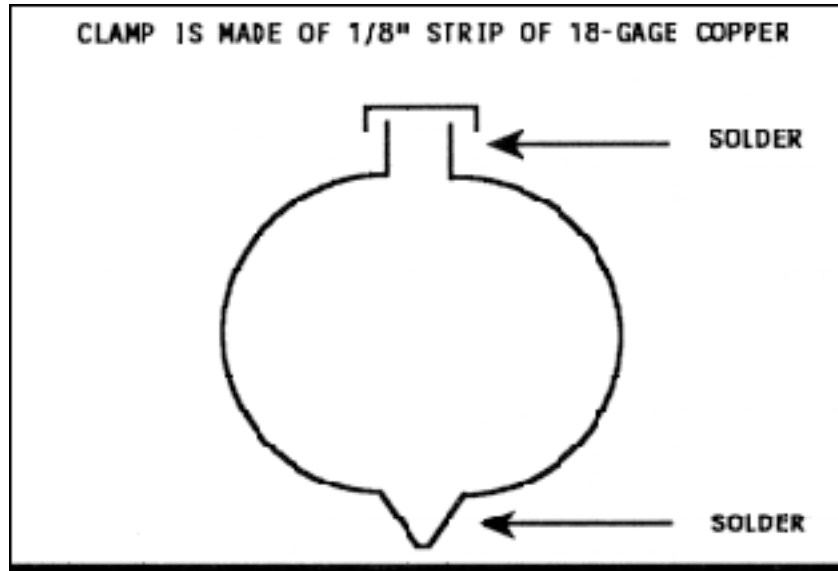
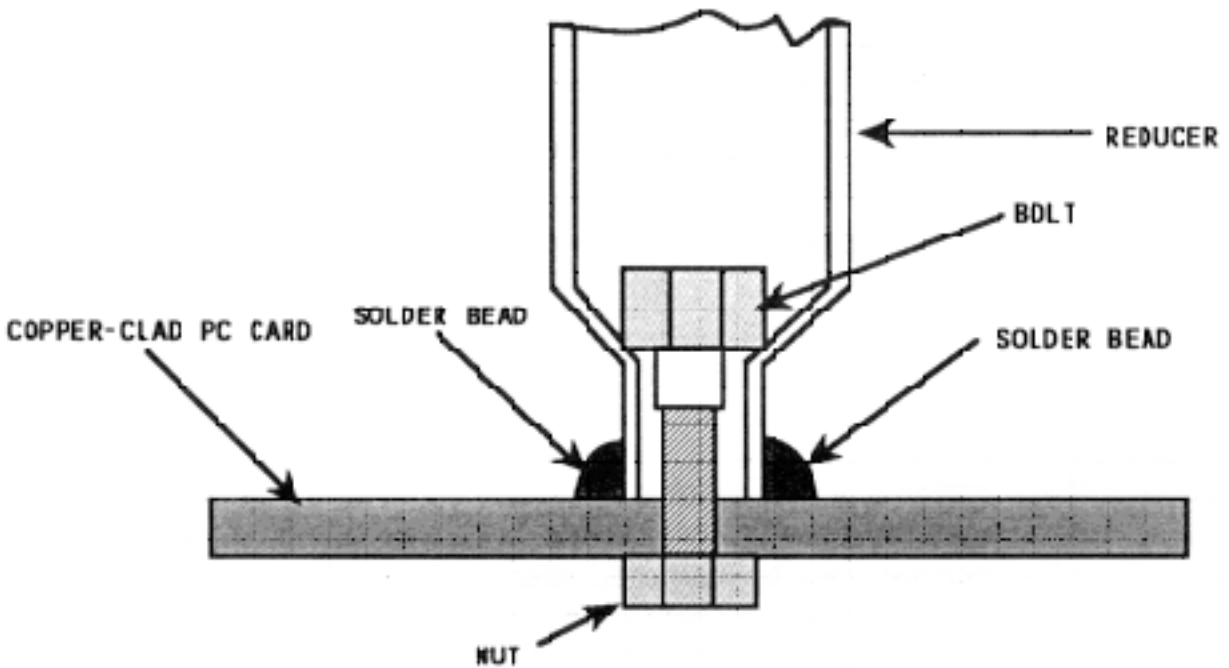
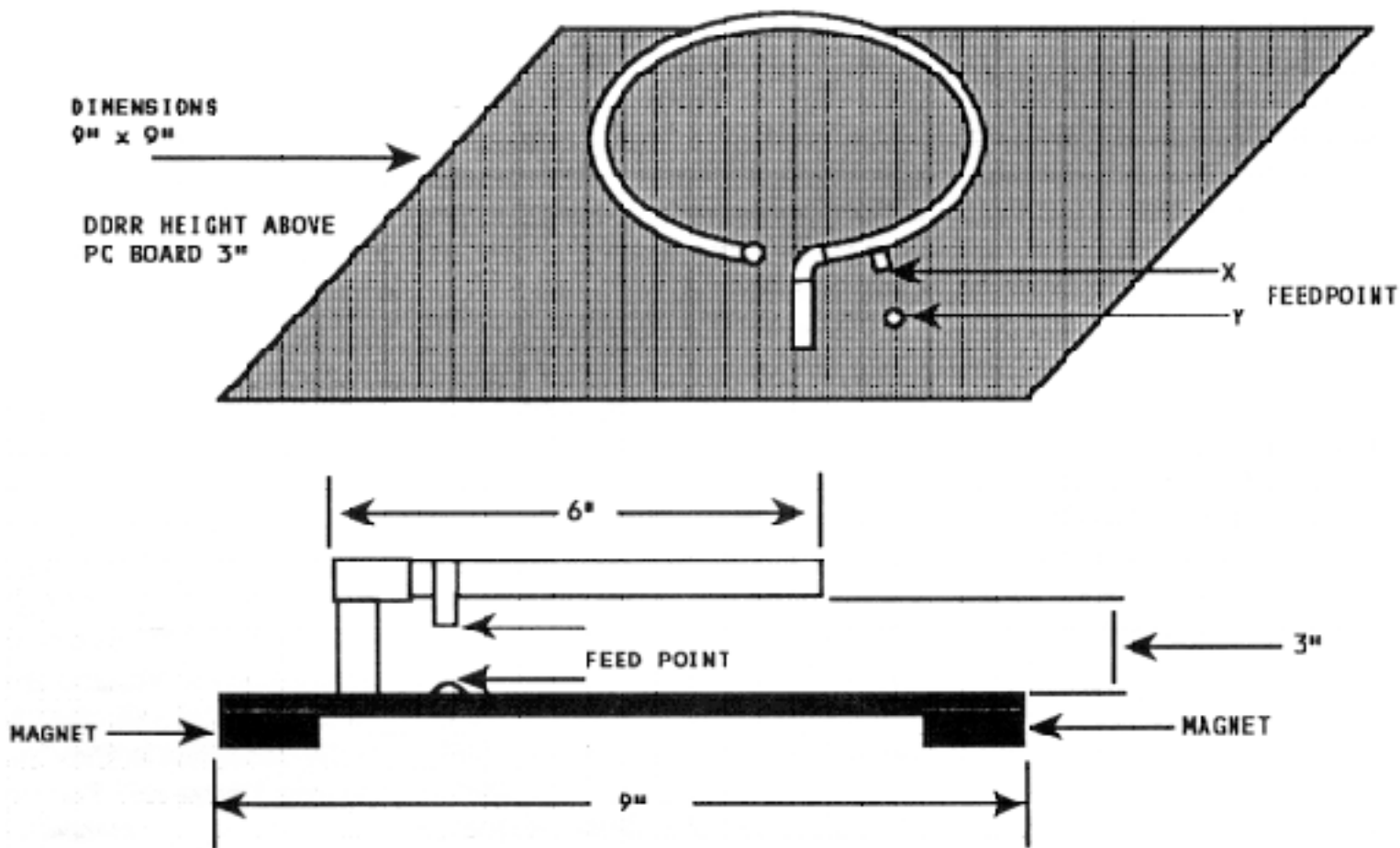

Figure 4





SPECIAL CONSTRUCTION DETAIL

Fixing the butt of the free loop of the Mark III to the ground plane took some real effort. I finally solved the physical problems by clamping a bolt inside the 2" vertical piece of 5/8" tubing in the jaws of a vise and clamping the tubing again below the bolt head to form a shoulder against which the bolt can be pulled tightly, securing the loop to the ground plane. Gently solder the butt to the circuit board, flaming the tubing and not the PC board. **-30-**

Send mail to webmaster@antennex.com with questions or comments.

Copyright © 1988-2004 All rights reserved - *antenneX*©

Last modified: July 04, 2004

The Cycloid Collinear, a CP Omni



Figure 1

Despite the advantages of circular polarization, amateurs have made little use of it. One of the main reasons is the difficulty in making a good circularly polarized omni-directional antenna (cp omni). This paper describes a wide band, high gain, multi-element cp omni with a single 50 ohm feedpoint with instructions for building a 2½ element cycloid collinear for 2 meters.

There are no commercially available cp omnis for amateur use [1], although there are many available for the fm broadcast band [2,3]. A common design is the cycloid which consists of a horizontal loop approximately $\lambda/2$ in circumference, with short vertical extensions at the loop ends [2,4]. The radiation from the horizontal loops is approximately

omni-directional and approximately equal to the radiation from the vertical sections (and is 90 degrees out of phase), resulting in circular polarization. The impedance of this antenna is not 50 ohms and requires a matching section [4]. If more gain is desired, then two or more elements can be stacked collinearly, with each element fed separately [2].

A simpler way to combine elements is to extend the vertical sections of each element until they touch. However doing this increases the vertical radiation and the antenna becomes mostly vertically polarized. Simulations have shown that this makes a very good vertically polarized omni with a small amount of horizontal polarization. The vertical polarization radiation can be reduced by reducing the diameter of the vertical wires [5]. The antenna described here is just such an antenna.

A test antenna was modeled for 146 MHz consisting of three horizontal loops

made of 3/8 inch diameter soft copper tubing and two #18 (0.040 inch diameter) vertical wires. Mininec is required for the modeling because nec cannot simulate an antenna made of two wires of very different diameters [6,7]. The design goal was to design a right hand circularly polarized antenna with 50 ohms impedance at 146 MHz.

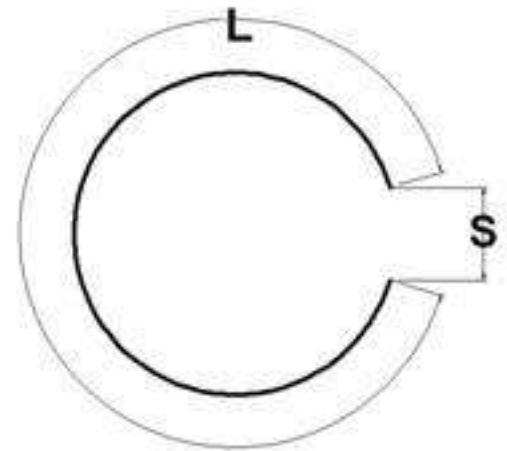

A loop drawing is shown in Figure 2. For the top and bottom loops, $L = 33 \frac{9}{16}$ and $S = 1 \frac{3}{4}$. For the center loop, $L = 28$ and $S = 1 \frac{1}{2}$. Cut the copper tubing to the lengths shown and bend them to approximate a circle with a gap as shown. All dimensions are in inches.

Then support the elements in some way. I used a ten foot length of $\frac{3}{4}$ inch schedule 40 pvc pipe. The spacing between the elements (and the length of the vertical wires) should be $57 \frac{7}{8}$ inches. Figure 3 shows how the vertical wires and the loops are connected together. This figure is drawn from the point of view slightly off axis from the top or bottom of the antenna. The polarization from an antenna assembled in this way is right hand circular polarization (rhcp). The antenna is fed in the center of the center loop through a balun.

Figure 1 shows the assembled antenna on the roof. No patterns were taken, but the good agreement between the simulated and measured SWR (Figure 4) gives confidence that the antenna is working properly.

The simulated gains at 146 MHz are:

Right hand circularly polarized gain = 4.54 ± 0.59 dB.

Vertically polarized gain = 2.76 ± 0.05 dB.

Horizontally polarized gain = 0.63 ± 1.45 dB.

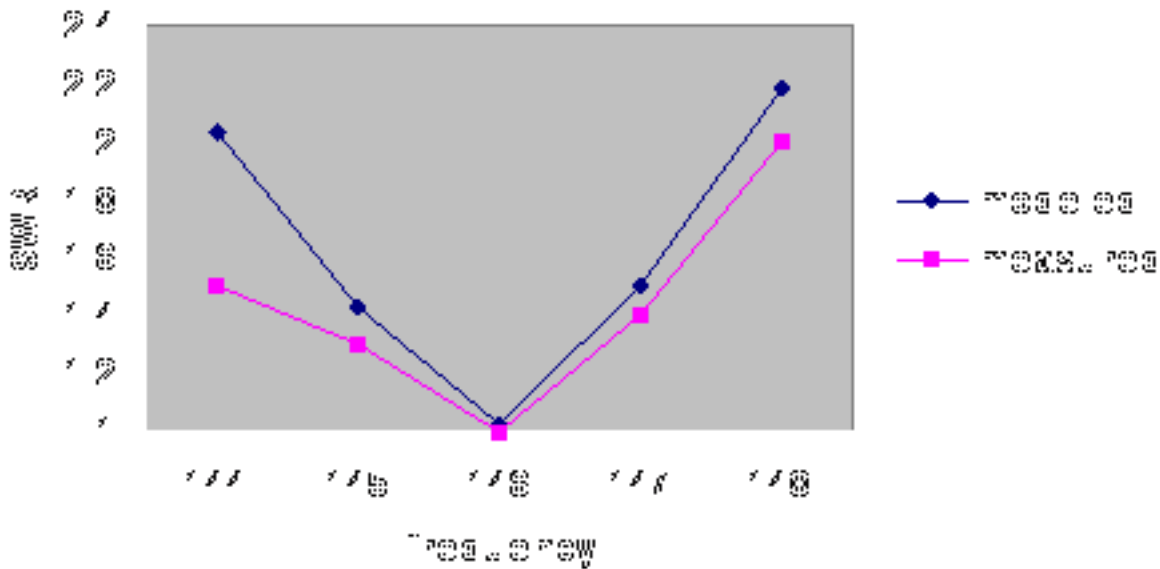

Figure 4

Adding more elements will improve the gain. If you decide to change the design goals using different diameters, more elements, or different frequency, you should resimulate using mininec. If you decide to make a mostly vertically polarized omni using the same diameter for the vertical and horizontal elements, then nec (which is more accurate than mininec) can be used.

I have not said anything about why you would want a cp omni. Please refer to the references for discussions on circular polarization.

Ross Anderson W1HBQ April 19, 2004 ross_anderson@comcast.net

References and Links

[1] GBPPR Tech Bulletin #2 - Advantages of Circular Polarized FM Repeater Antennas http://www.qsl.net/n9zia/cir_pol_rpt.html

[2] <http://www.progressive-concepts.com/37a.html>

[3] <http://www.psibroadcast.com/antenna-fm.asp>

[4] The WA7X Beacon The Cycloid Dipole
http://www.wa7x.com/cycloid_info.html

[5] The Simple Collinear http://home.comcast.net/~ross_anderson/sc.htm

[6] When MININEC is Superior to NEC
<http://www.cebik.com/amod/amod56.html>

[7] I use K6STI's AO. His e-mail address is bb at n2 dot net.

Circular Polarization References:

<http://www.astronautennas.com/polarization.html>

<http://www.scott-inc.com/html/fmant.htm>

<http://www.madsci.org/posts/archives/feb2001/983649000.Eg.r.html>

<http://www.rwonline.com/reference-room/better-fm-cov/bfc-03-27-02.shtml>

<http://webpages.charter.net/n4wyk/satants.htm>

<http://www.n2.net/k6sti/attic.htm>

<http://www.amsat.org/amsat/articles/w6shp/lindy.html>

<http://www.radiobooks.com/products/2mcp14.htm>

http://hjem.get2net.dk/ole_nykjaer/oz2oe/xyagi/build_yagi.html

http://home.comcast.net/~ross_anderson/quadix.htm

My homepage “Ross’s Antennas” with links to my other pages is

http://home.comcast.net/~ross_anderson

keyword: omnidirectional

The HO Collinear, a Horizontal Omni



Figure 1

This paper describes a high gain, multi-element horizontal omni with a single 50 ohm feedpoint with instructions for building a 4 element array for 2 meters.

There are several ways to make a horizontal omni [1,2,3,4,5]. One popular type is the HO which is a half wave dipole folded into a square or a circle [6,7]. The impedance of this antenna is not 50 ohms and requires a matching section. If more gain is desired, then two or more elements can be stacked collinearly, with each element fed separately through power dividers.

A simpler way to combine elements is to connect the loops together by adding vertical extensions to the ends of each loop. The lengths of the loops and vertical wires are adjusted for maximum horizontal

gain consistent with a 50 ohm feedpoint in the center of the bottom loop using an antenna modeling program. Since I decided to use 3/8 inch diameter soft copper tubing for the horizontal loops and # 18 wire for the vertical wires, I used mininec because nec cannot be used for antennas made of two wires of very different diameter [8,9]. It is possible to build this antenna with only one diameter wire, in which case nec can be used [10].

A test antenna was made for 144.5 MHz consisting of four horizontal loops made of 3/8 inch diameter soft copper tubing and two #18 (0.040 inch diameter)

vertical wires. A loop drawing is shown in Figure 2. For the top and bottom loops, $L = 31 \frac{7}{16}$ and $S = 1 \frac{5}{8}$. For the middle loops, $L = 28 \frac{5}{16}$ and $S = 1 \frac{1}{2}$. Cut the copper tubing to the lengths shown and bend them to approximate a circle with a gap as shown. All dimensions are in inches.

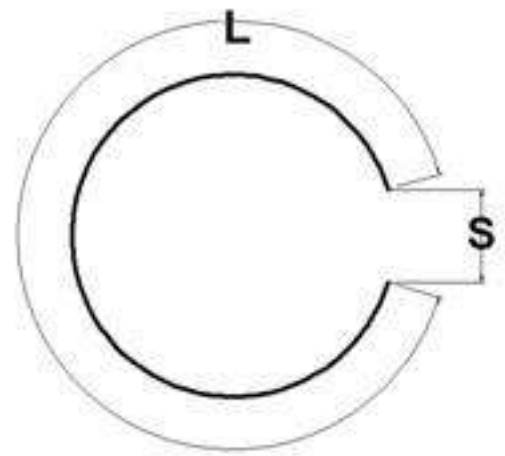

Then support the elements in some way. I used a piece of $\frac{3}{4}$ inch schedule 40 pvc pipe. The spacing between the elements (and the length of the vertical wires) should be $20 \frac{7}{8}$ inches. Figure 3 shows how the vertical wires and the loops are connected together. This figure is drawn from the point of view off axis from the top of the antenna. The antenna is fed in the center of the bottom loop through a balun.

Figure 1 shows the assembled antenna on the roof. No patterns were taken, but the SWR (Figure 4) agreed with the simulated SWR (except for a 1% frequency offset error) which gives confidence that the antenna is working properly. The simulated gain is 3.27 ± 1.22 dBi.

Figure 4

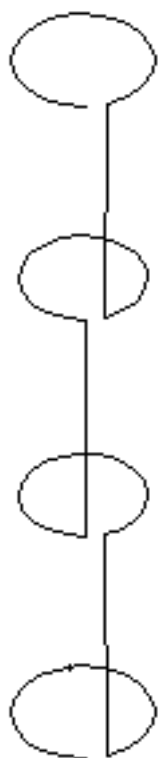
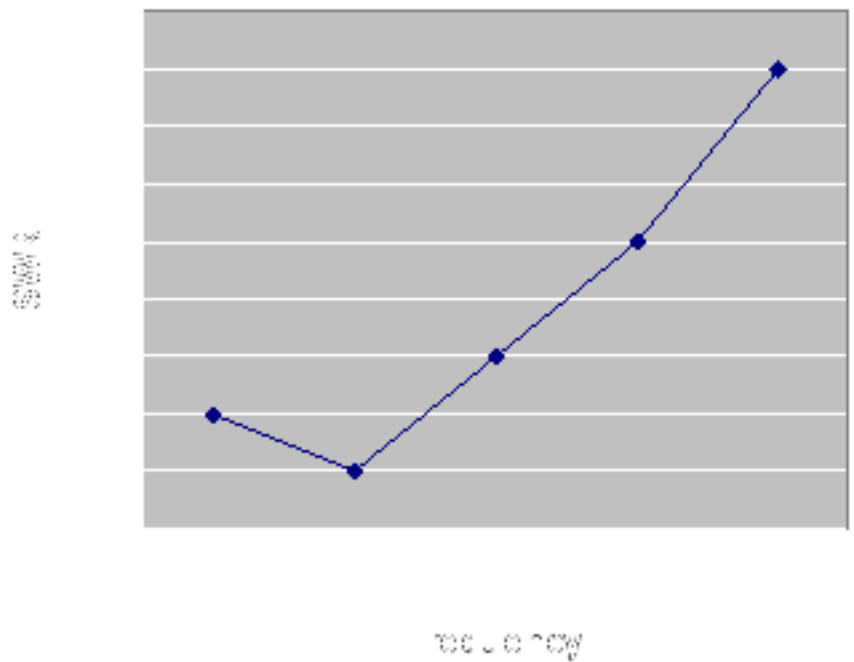

Figure 3

Adding more elements will improve the gain. If you decide to change the design using different diameters, more elements, or a different frequency, you should resimulate using mininec. Mininec



typically has frequency offset errors, so the final design may have to be tweaked a bit. I increased the vertical wire lengths from 20 to 20 7/8 inches from my original simulation (keeping the loop lengths the same). The frequency can also be adjusted by varying the gap at the end of the loops. Closing the gap lowers the resonant frequency (and also the impedance). Increasing the gap increases the gain variation (ie, makes it less omni). If you decide to use the same diameter for the vertical and horizontal elements, then nec can be used, but it may not be possible to get to 50 ohms.

One further comment. The spacing between the loops is smaller than is usually used in collinear arrays. This is because the electrical length between the centers of each loop is a half wavelength. The radiation from the loops is kept in phase by reversing the wire direction between adjacent loops (See Figure 3).

Ross Anderson W1HBQ May 21, 2004 ross_anderson@comcast.net

References and Links

[1] The Eggbeater EB-144

http://www.wb0w.com/m2/2mtr/2_meter_antennas.htm

[2] The Batwing <http://www.qsl.net/kd2bd/batwing.html>

[3] The Turnstile <http://www.cebik.com/turns.html>

[4] The Wheel <http://www.hamtv.com/wheel.html>

[5] Omniangles <http://www.parelectronics.com/omnis.htm>

[6] 2M HO Loop http://www.wb0w.com/m2/2mtr/2_meter_antennas.htm

[7] KB6KQ Loops <http://www.kb6kq.com/products.html>

[8] When MININEC is Superior to NEC

<http://www.cebik.com/amod/amod56.html>

[9] I use K6STI's AO. His e-mail address is bb at n2 dot net.

[10] I use 4nec2 by Arie <http://www.qsl.net/wb6tpu/swindex.html>

My homepage "Ross's Antennas" with links to my other pages is http://home.comcast.net/~ross_anderson

keyword: omnidirectional

Fan-tenna... An antenna made from a fan?

Did you ever look at a broken household item and think 'I can't throw this out, there just must be some use for it in my ham shack'? That was the case when our fan gave up the ghost one summer. The more I looked at the metal cage of that fan, the more it started to look like the perfect radial system for some future two meter ground plane antenna.

Some quick figuring ($234/\text{Frequency [MHz]}$), showed that if the cage radius is anywhere near 19 inches, it would make a 'fan-tastic' ground plane. As it turned out, my cage had a smaller diameter, in fact it was only about 10 inches, but I went ahead with the project anyway.

In an effort to create an easy to build, not to mention cheap, antenna, I decided to raid the hall closet to confiscate an old wire hanger to use as the vertical portion of the ground plane. I cut the wire a bit long to leave plenty of room for adjusting to a 1 to 1 SWR. With the help Bob (N3LSS), and his 2 meter hand held, we cut and trimmed, and ended up with a textbook 19.25" vertical radiator and a perfect match.

Construction:

Construction is extremely simple. First you'll need a connector, to properly mate with the one on the end of your coax. I used an SO-239 connector from my junk box. Insert the connector through the center of one side of the fan cage. My fan cage conveniently separated into two halves and provided easy access for mounting the connector.



If the center section of your cage is plastic, be sure to attach a jumper from the connector to the metal portion of the cage.

Solder the coat hanger to the connector.

Lastly, attach your coax after routing it through the back side of the other cage half.



If you like to tweak and prune, start with a vertical length of about 21 inches. Cut off only 1/4 - 1/2 inch at a time! If you don't have access to an SWR bridge for the two meter band, just cut the whip to 19 1/4 inches and your match will be very close.

If outdoor use is anticipated, I'd suggest using an aluminum rod in place of the coat hanger in order to survive the winds.

Although a 19 inch radius cage is optimum, as this design shows, a cage diameter even half that size works so don't bother to try and modify its length at all.



Pretty 'fan-cy' huh?

Test out:

But does it work? We are fortunate to have access to a local repeater which has a unique feature. It provides a voice announcement of your signal strength into the repeater. A quick test with the new fan-tenna indoors, in front of a window, and on the ground floor, provided a better than expected 30 over signal.

Additional tests from the same location, using the hand held's existing whip, proved that the new ground plane was far superior and provided an amazing improvement in gain. Yes indeed, this antenna does work!

[Antenna Construction Tips](#)
[Back to the Antenna Elmer](#)
[Back to the Home Page](#)

All trademarks mentioned belong to their respective owners.

The content on this page is provided as is, and should be accepted and used without expecting any particular fitness for any particular purpose. No liability is assumed with respect to the use of this information.

© Copyright 1996 – 97 Edward Oros and Bob Cocco

Build a hanging dipole for two metres

Described here is a simple omnidirectional, vertically-polarised dipole for two metres. Made from coaxial cable, it can be rolled up and stored in a small container. It may be used as is indoors, or waterproofed for use outside. No extravagant gain claims are made; this dipole has no more gain than any other. However, it should be significantly more effective than the antenna that came with your handheld. The cost of building the project is around five to ten dollars. Allow about 20 minutes to construct and erect the antenna.

A single length of 50 ohm coaxial cable forms both the antenna element and the feedline. The antenna is made by removing a quarter wavelength of outer jacket and bending the braid back along the cable towards the transceiver to form a vertical dipole. This means no metal work or wiring is required (apart from attaching the BNC or PL259 plug).

Download this image for a drawing of the completed antenna.

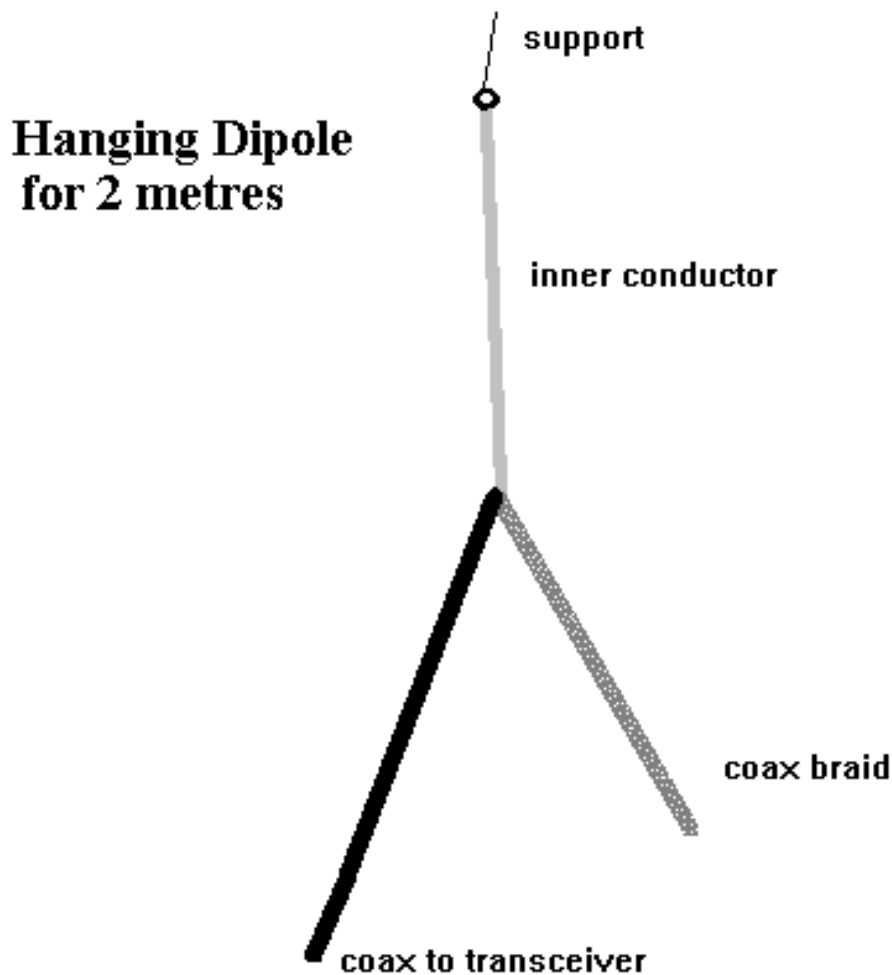

(c) 1998 VK1PK

Parts required

The following is required to complete the project:-

- 3-4m RG58 coaxial cable (not critical - use longer length if height is needed or the operating position is distant from the antenna)
- PL259 or BNC plug (to suit transceiver)
- small metal lug, washer or nut
- tape measure, scissors, small screwdriver, long-nosed pliers, multimeter, fishing line, soldering iron

Construction

- Solder the PL259 or BNC plug to one end of the RG58 cable.
- From the other end of the cable remove 48 cm of the black plastic outer covering to expose the braid.
- With a small screwdriver (Phillips head is best) gently part the braid to make a small hole near where it ceases to be covered by the plastic jacket. Aim to make it about 5mm in diameter.
- Use either pliers or a screwdriver to pull the inner conductor out from inside the braid through the hole in the braid (Fig 2c).
- Fold the braid back along the cable towards the plug. Solder the end of the braid to prevent fraying.
- Remove about 5mm insulation from the inner conductor.
- Solder the end of the inner conductor to a small metal lug or nut.
- Thread fishing line through the lug or nut and hang the antenna in its desired position.

The antenna is now operational. You may wish to check the SWR and make it longer or shorter if the SWR is above about 1.5:1 at 147 MHz.

Erection and use

The antenna should be hung vertically for best performance. Keep it away from metal objects and have it as high as possible. Where signals are weak, hang the antenna near a window facing the repeater. If you intend to use the antenna outside, apply sealing compound to stop moisture entering the cable. Not doing this will mean poorer performance over time as cable losses increase.

[back to Peter Parker's Project Page](#)

This page was produced by Peter Parker VK3YE (ex VK1PK) (parkerp@alphalink.com.au). The page is continually under construction. Material may be copied for personal or non-profit use only.

The Grid Yagi

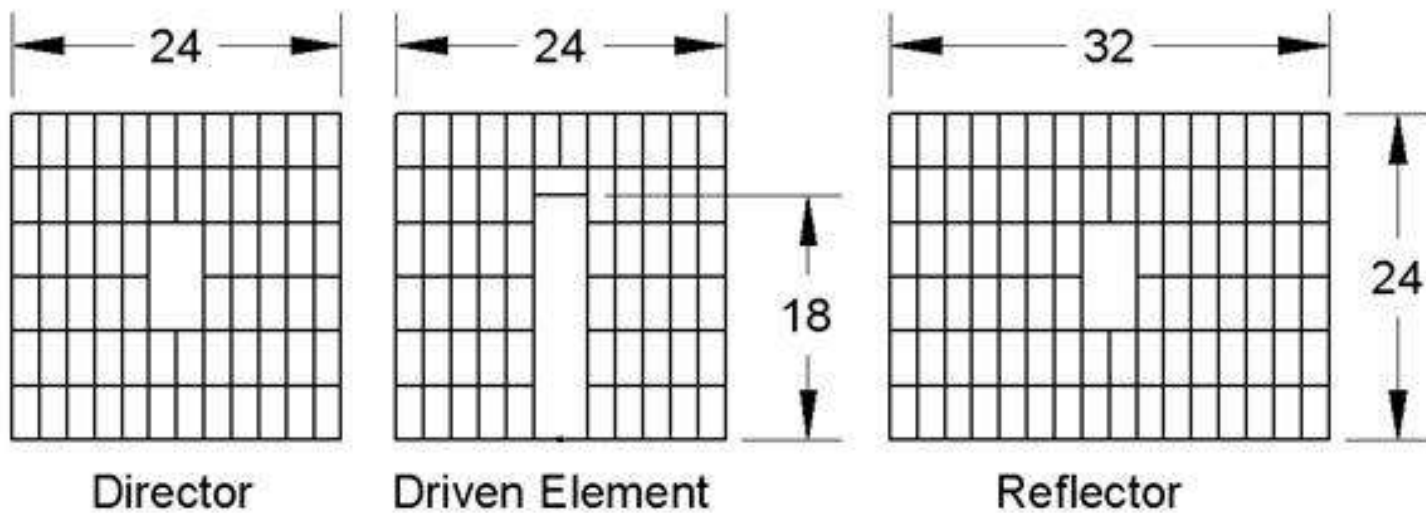

Figure 1

The Grid Yagi (or Grid Quad) is a high performance yagi antenna that can be built with readily obtainable inexpensive materials. Described here is a 6 element 2 meter version with a boom length of about 1 wavelength, shown in Figure 1.

The boom is made of 1½ inch pvc pipe, although any suitable material can be used, such as steel, aluminum, fiberglass, or wood. The elements are cut from 2 inch by 4

inch galvanized welded wire fencing, with a wire diameter of 0.078 inch, which is what #14 steel wire becomes when it is galvanized, and are shown in Figure 2. This fencing material and pvc pipe are available in any hardware store. The driven element and the four directors are all 24 inches by 24 inches. The reflector is 32 inches by 24 inches. The driven element has an 18 inch slot in it and is fed at the bottom of the slot. At the other end of the slot is a shorting wire.



Figure

2



I attached the elements to the boom using 1/8 inch diameter fiberglass rods. Holes were drilled in the boom, and the rods passed through the holes and around the wires of the elements, two rods per element. Figure 3 shows the two fiberglass rods passing through the boom and around the wires of director D4. Rods were also used to stiffen the driven element where the feed slot was cut (not shown). The fiberglass rods were obtained locally at Tap Plastics [1]. It should be possible to use other stiff materials such as shish-kabob skewers. The

element positions are shown in the Table. The elements can be glued in place or left unglued for easy disassembly.

Figure 3

| Elements | Position |
|----------|----------|
| REF | 0 |

| | |
|----|-----------|
| DE | 12 inches |
| D1 | 24 |
| D2 | 38 |
| D3 | 63 |
| D4 | 86 |

Simulations were done using 4nec2, Arie's version of nec2, available free at Ray Anderson's Unofficial NEC Archives [2].

The antenna was fed with approximately 50 feet of RG-8 type coax with a measured loss of 1.3 dB through a W2DU type balun [3] with three Amidon beads, type FB-43-1020 [4]. Figure 4 shows the simulated and measured SWR. The SWR measurement was done using a MFJ-259B SWR Analyzer. I could have adjusted the length of the slot to move the SWR minimum to another place in the band if I desired.

The simulated gain is 11.9 dBi at 144 MHz, 12.1 dBi at 146 MHz and 12.3 dBi at 148 MHz.

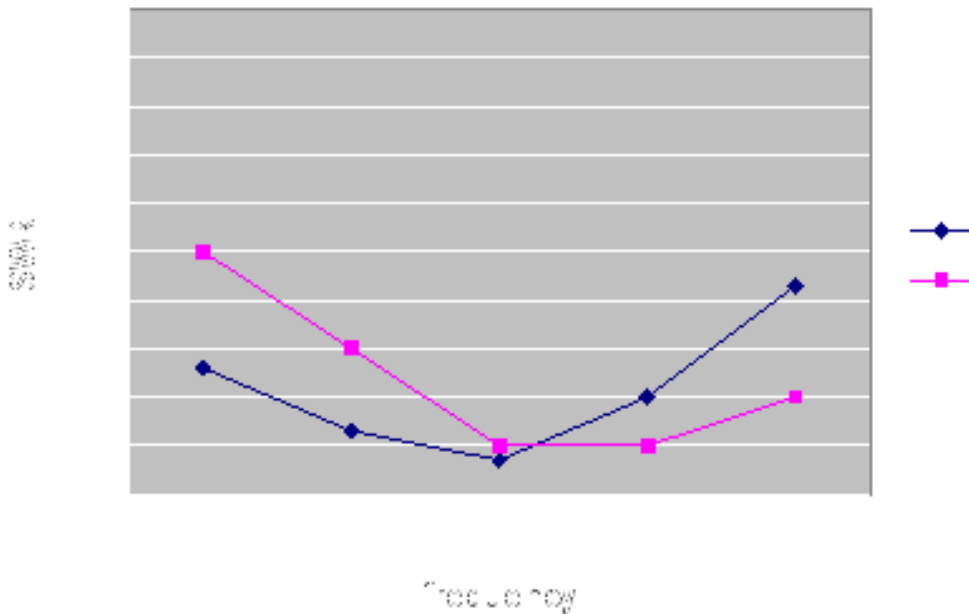

Figure 4

Ross Anderson W1HBQ February 15, 2004 ross_anderson@comcast.net

References and Links

- [1] <http://www.tapplastics.com/shop/product.php?pid=159>
- [2] <http://www.qsl.net/wb6tpu/swindex.html>

[3]

<http://home.iag.net/~w2du/Reflections2Chapter21SomeAspectsoftheBalunProblem.pdf>

[4] http://www.amidoncorp.com/aai_ferritesshieldingbeads.htm

My homepage “Ross’s Antennas” with links to my other pages .

http://home.comcast.net/~ross_anderson

Keywords: disc yagi, loop yagi

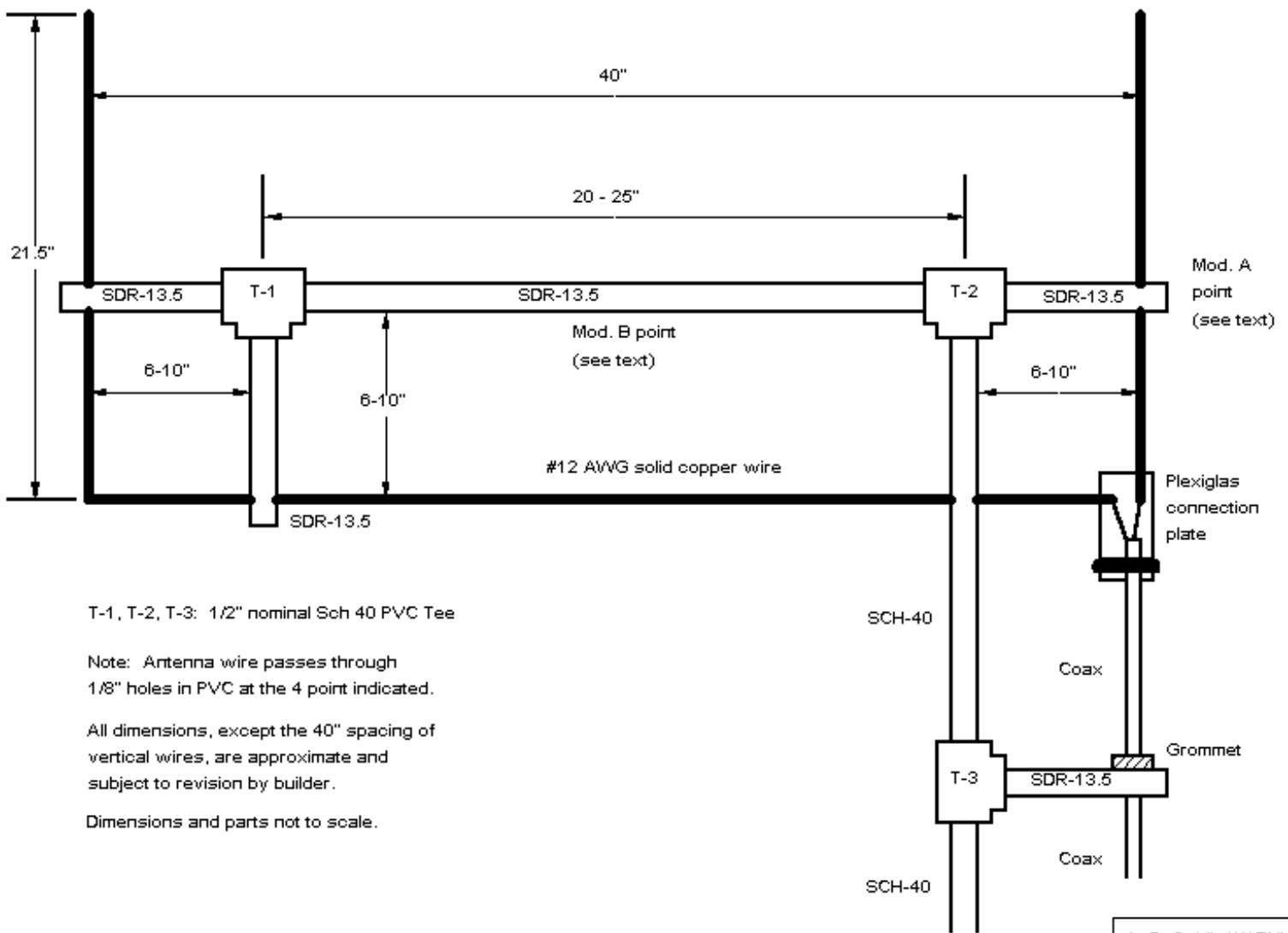

L. B. Cebik, W4RNL

Figure: 1

Title: Sketch of 2-Meter Half-Square PVC Support System

Project: 2-Meter Half Square

October 9, 1998

YOU CAN BUILD A 5/8th WAVE STACKED J-POLE FOR ABOUT \$20.00!

PVC 3/4"
10' WHITE



GROUNDING WIRE



14 SOLID COPPER ABOUT 12"

WOOD DOWL



Can be added for stiffness and stability



A PACKAGE OF WIRE TIES TO BE USED TO ATTACH AND HOLD WIRE TO PVC

COPPER WIRE # 6 SOLID 161 1/2" TOTAL

MEASURE AND MARK REFERENCE POINTS ON WIRE

PLACE WOOD DOWL INSIDE PVC AND DRILL HOLES

MAKE FIRST BEND IN WIRE AT "BEND-a" AND FEED WIRE THROUGH

AFTER MAKING THE REST OF THE BENDS AND FITTING THE WIRE TO THE PVC PLACE WIRE TIES ABOUT EVERY 12" TO KEEP WIRE STATIONARY

TIP: HOT GLUE THE WIRE TIES TO THE PVC...

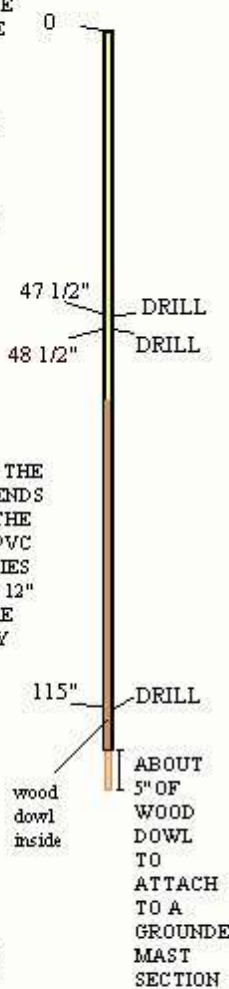

SHOULD LOOK SOMETHING LIKE THIS WHEN YOUR DONE

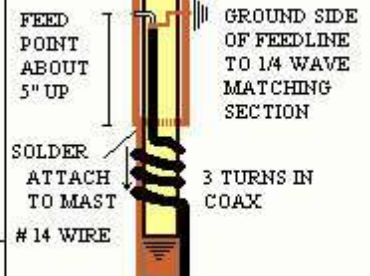
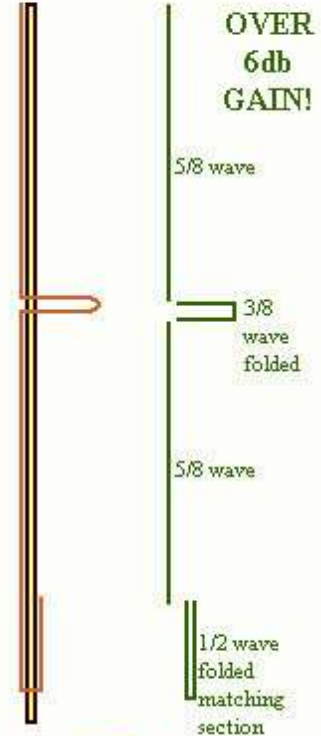

STEVE KB1DIG e-mail: govener@nh.ultranet.com

5/8 stackad Jpole för 2 m

Byggbeskrivning

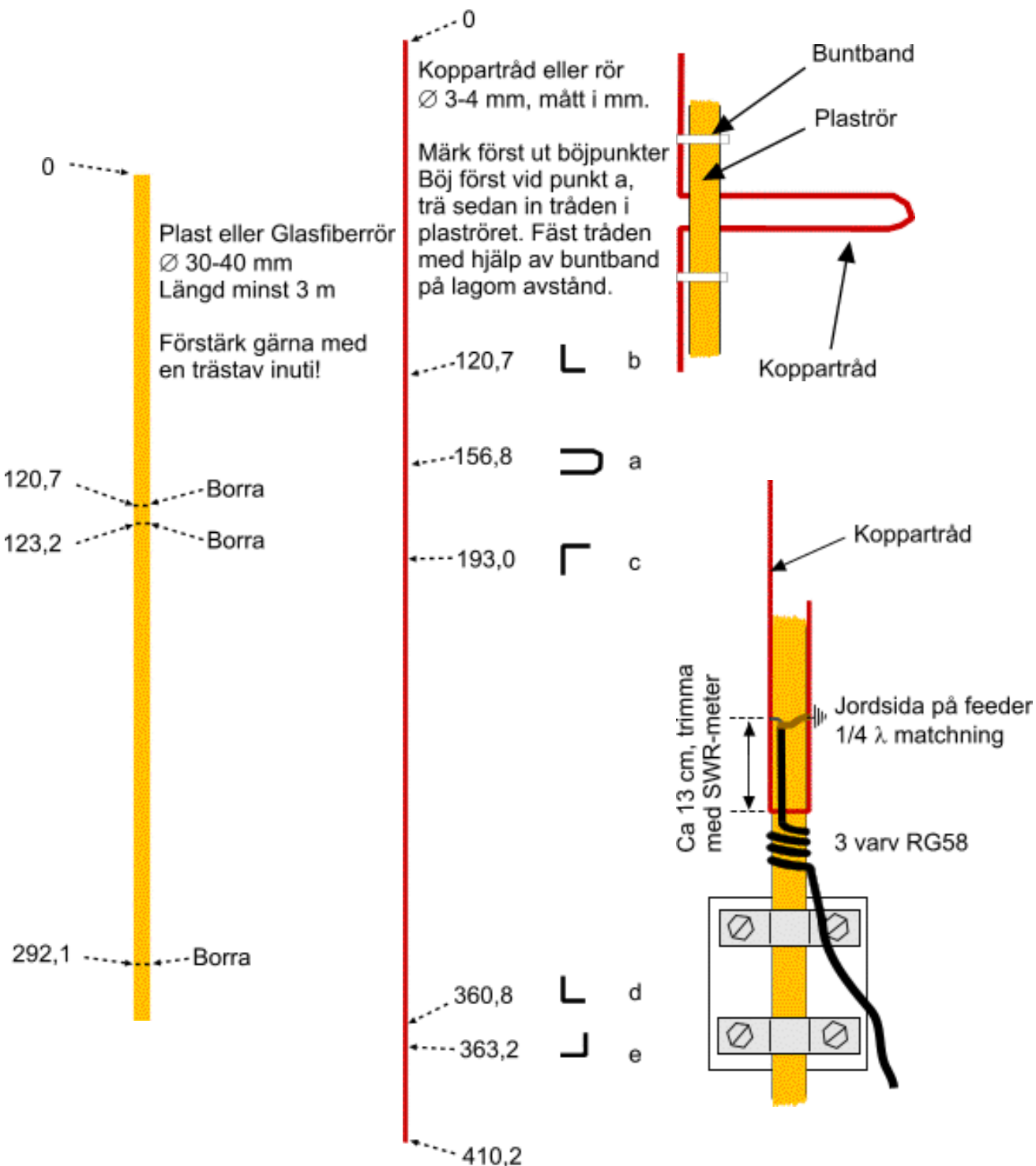

[Föregående sida ...](#)



CHECK THIS OUT!

NEW LED Projects!



NEW Local ARES Web Project!



VHF ANTENNA Projects and Ideas:

2 METER ANTENNA DESIGN GALLERY



The KB1DIG & KB1GTR Ham Page

The J-pole is one of the most popular home-brew antenna designs for vertical 2-meter Amateur Radio. Another interesting home-brew project idea is the Halo design horizontal antenna. I did some experimenting with a few variations of these type of antennas and came up with the designs posted on this page. The main reason I considered building my own antennas was to gain a greater understanding of RF technologies and to save some money in the process. Each antenna has a unique use and are actually fun to build. Most of the parts can be found at your local hardware store. If you try one of these please drop me a line to let me know how it turned out.

Send E-mail to: buck0@comcast.net  Good luck building! 73's Steve KB1DIG

Personal note: 11/21/01

Please understand that the intent of this new section is not to sound off or show off. This is the first addition I've made to this page in quite some time. I was worried about changing something because it has become so popular. Links to this antenna page have been turning up all over the Web. That's great! I've enjoyed answering all the e-mail. A lot of things have happened in the last few months that have inspired me to continue this new project. My wife, Kim, now has her Ham ticket! Her Call is KB1GTR and I'm very proud of her. We both had the opportunity to help with the [NYC/WTC Relief Effort](#) through the [Salvation Army Team Emergency Response Network, or SATERN](#). We were working with Logistics Communications from Oct. 7th through Oct. 18th. Looking back on our experiences, we determined the need to expend our capability for emergencies on a daily basis. Aside from already being involved with [local 2-Meters as Net Control Operators](#), we recently joined the [New Hampshire ARES/ RACES](#).

Thanks for all of your support! 73's Steve KB1DIG

we remember...the day the world changed

Personal note: 11/15/03 [Please click here](#)

Ladder Line J-Pole
2-Meter 1/2-Wave
1 Element



COPPER J-Pole
2-Meter 1/2-Wave
2 Element Collinear



INSIDE PVC J-Pole
2-Meter 1/2-Wave
2 Element Collinear



EMERGENCY J-Pole
2-Meter 1/2-Wave
2 Element Collinear



OUTSIDE PVC J-Pole
2-Meter 5/8-Wave
2 Element Collinear



"A Dedication to Emergency Service"

This is an off-site link to an article that appeared in the ARRL's QST Magazine, April 2002:

<http://www.qsl.net/ka1ddb/adedicationtoemergencyservice.pdf>

"A Dedication to Emergency Service" *Compiled and Edited by Rick Lindquist, N1RL.*
It tells our story, along with several other Amateurs that were there to help after 9-11-01.

Also, a link to the Mich-A-Con Amateur Radio Club main Webpage:

<http://www.qsl.net/ka1ddb>

EMERGENCY EQUIPMENT IDEAS

GO KIT: DAILY EMERGENCY COMMUNICATIONS GEAR IDEAS

Nov. 21st, 2001, By Steve KB1DIG & Kim KB1GTR



How do we get all this HT equipment out of the drawer and into our hands when we need it? With a little research, we came up with the ideas and links posted in this section. Our favorite *quote* comes from [C. Edward Harris, KE4SKY, VA RACES State Training Officer](#): "It is better to have the bare essentials always handy than to leave a bulky pack someplace where you can't get to it." This has been our inspiration for this project. As always, we are open to your suggestions and comments.

THE BOX: PORTABLE EMERGENCY COMMUNICATIONS STATION IDEAS

Jan. 9th, 2002, By Steve KB1DIG & Kim KB1GTR



Time for Plan B! This is a spin-off of the Go Kit project. Intended for portable long-term usage and also good for Field Day Events. Something requiring a little more power output than the HTs. A diamond in the rough. This "Box" is going to be under constant refinements this year with your suggestions and comments.

**HALO 2-Meter
1/2-Wave Loop
SSB-FM-CW**



6 METER ANTENNA DESIGN

**HALO 6-Meter
1/2-Wave Loop
SSB-FM-AM-CW**



SOME ANTENNA WEB LINKS

[ARRL Web:
Antenna Projects](#)

[AC6V's HOMEBREW
ANTENNAS LINKS](#)

[Amateur Radio
Information](#)

[Antennas and ATV](#)

[Jim's Notebook Index](#)

[HAM UNIVERSE
by Don N4UJW](#)

[Amateur Radio
Reference Library](#)

[Harry's Homebrew
Homepage](#)

[W4ZT 2 Meter
Dipole Antenna](#)

[W4RNL](#)

[Antenna Projects](#)

NEW

Anderson Powerpole Ideas: Get Everyone Connected!

Nov. 6th, 2003, By Steve KB1DIG & Kim KB1GTR



[Anderson Power Products and Powerpole® connectors.](#) We have been doing research on this product and here are some of our findings. This overview may be familiar. Most of this information was found from different sources on the Internet and several Web links are listed on this page. We hope this will offer some new insight into how to go about integrating this Anderson Powerpole product into everyone's emergency power equipment needs. Our suggested attempts at leveling the playing field.. Also, keeping costs reasonable for the high-tech low budget practical minded Amateur in all of us. We are not experts and have no affiliation with the manufacturers or sales vendors mentioned. If you have something to contribute to this page and topic please send us your ideas and comments.

EMERGENCY LINKS

Amateur Radio Emergency Web Resources

RACES

Click



Radio Amateur Civil Emergency Service

TAKE A BREAK !

To this end we present the intermission section.

Technology for Country Folk

You Know You're a Ham if

NOTICE TO ALL VISITORS

NEW

Little Dilbert and the Knack!

Our place to have fun and a place for you to enjoy.

[Ham Radio Antennas](#)



DXZONE.COM
The DXZone DXZONE.COM

[Rate this Site @ The DXZone](#)

K1DWU

Ham Radio News, Links,
Classifieds and Much More

eHam.net
ham radio on the net

PLEASE CHECK OUT THESE HOME PAGES

[Steve's and Kim's First Home Page!](#)

[Welcome to PatNJak.com](#)

EQUIPMENT AND PROJECTS

ARES/RACES

Our Mission

Activation Plans

Projects

Local Nets

Events & Training

ARES Application

Net Control Script

EC Report

The following are some good emergency antenna projects to consider building. There are several reasons to consider building your own antennas for emergency work which include:

1. They are not expensive so if you loose them, or they get destroyed during the event you're not out big bucks!
2. You will gain a greater understanding of RF technologies especially antenna design.
3. You will learn how to improvise!
4. Last but not least, its fun!

Each antenna has a unique use. Please consider experimenting and playing! Share your success on the weekly nets as well!

[Build a J-Pole for any frequency - Includes an Excel Spreadsheet!](#)
[Plans for a J-Pole](#)

[Pocket J-Pole](#)

[Half Wave J-Pole](#)

[Stacked 5/8](#)

[Field 2 meter Colinear](#)

[2 meter Colinear in PVC](#)

[2 meter Halo](#)

[Eggbeater Loop Antenna](#)

[HF Antenna Designs](#)

[Trickle Charge Circuit](#)

Off Site Plans

[NVIS](#) Short Range Antenna Systems for HF

[NVIS](#) Discussions

[KB1DIG's](#) Home Site

[Copper Cactus Plans](#)

[N7QVC's J-Pole Plans](#)

[St. Louis Vertical](#) (10-40m)

[Windom](#) - 6 bands in one antenna

[Quickie Vertical-](#) By KQ6RH

[Wide Band Folded Dipole](#)

[Horizontally Oriented, Horizontally Polarized Large Wire Loop Antennas](#)

Disaster Supply Kit

Being ready for an event or disaster requires preparation before the call comes. This means getting a supply kit together and knowing what is in it. We have [included a article](#) to help start your list.

Number of visitors:

067395

n2njh@arrl.net

Buffalo, NY - USA

©Copyright 1997-2000

This page was last updated on : undefined

The HAM Radio Operator's Antenna Handbook Page
another web site by;



"Home of the RASCAL"

115 and 211 LUENBURG DRIVE; EVINGTON, VA 24550 FAX 434 525 7818

For TNC to Radio Interface Cable Diagrams, CLICK HERE !

For PSK31 & SSTV Interface Diagrams, CLICK HERE !

- [!\[\]\(49aa2e1da5fe39294864e9598c593810_img.jpg\) Of all HF antennas, the multi-band WINDOM is my favorite.](#)
- [!\[\]\(7d0a8d8b1031f74abe67b09fcf4a2322_img.jpg\) An improved 6 Meter "High-Performance" Base-Station Dipole.](#)
- [!\[\]\(6557fa7496e6a507d2326ea0bef061ee_img.jpg\) HF Antenna Cutting Chart](#)
- [!\[\]\(1fe0339452ba17bd8ae951d8509f80d6_img.jpg\) VHF & UHF Antenna Cutting Chart](#)
- [!\[\]\(3f7dbef097b87c46047901c2927193e7_img.jpg\) Determine correct spacing between antennas to achive proper isolation.](#)
- [!\[\]\(f421354329041d30b231dbd0377dc4a4_img.jpg\) A two meter dipole](#)
- [!\[\]\(4557a7673fde5aee3dcfc3acbc13f50f_img.jpg\) It's very portable and EZ to build; A TV twin-lead two meter J-Pole](#)
- [!\[\]\(a09c8052b98b7778d2c72346d2066777_img.jpg\) Detailed drawing of a two meter "J" Pole antenna.](#)
- [!\[\]\(d61d07e9eb9cac37db01dc55c45bd685_img.jpg\) Detailed drawing of a six meter "J" Pole antenna.](#)
- [!\[\]\(c84ad9254f5730201f5f3718afff882d_img.jpg\) Design your own "J" Pole antenna.](#)
- [!\[\]\(276ec537567fc95a4cf49492e4c3723a_img.jpg\) Design your own QUAD antenna.](#)
- [!\[\]\(a99469d8f0e6e59d040348232f79b6e0_img.jpg\) A 4 element, six meter QUAD design using *Design-A-Quad*.](#)
- [!\[\]\(ec5cec4e6a6205b97fa8e187851ae5ed_img.jpg\) Antennas and Antenna RF Meters](#)

BUT FIRST.... let's review some antenna "basics" in pictorial form.



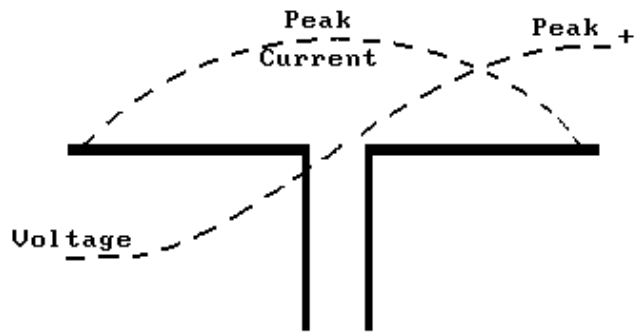

The basic dipole consists of two charges or elements which receive signals of opposite polarity.

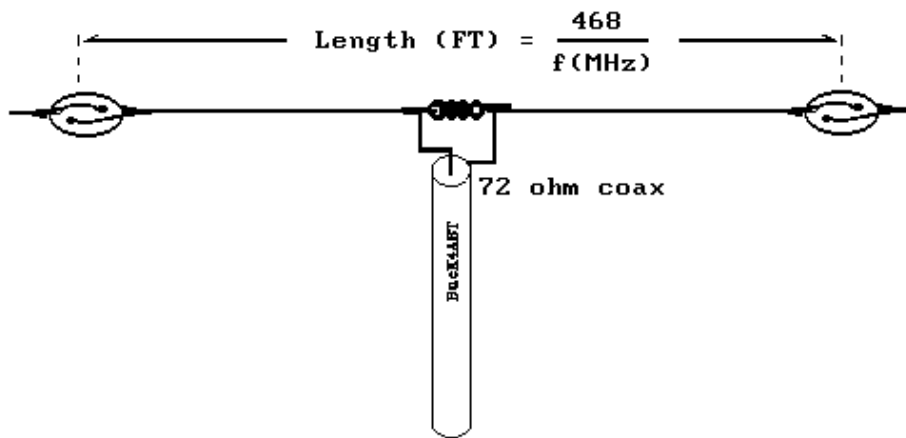

A dipole is a half-wave antenna fed at the center. The impedance at the center is near 72 ohms.

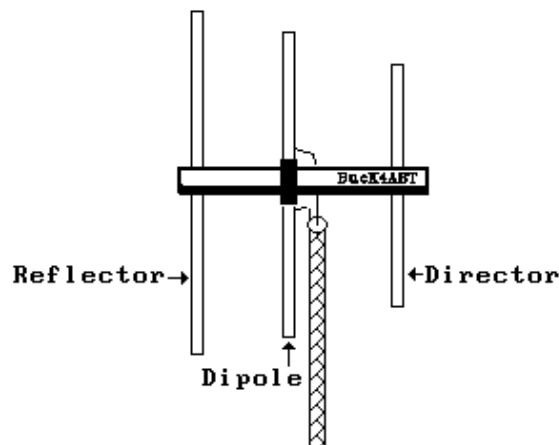

Adding a reflector and a parasitic element (director) to the dipole greatly improves its gain and directivity. Thus, the dipole becomes a "YAGI" antenna.

[Good photos of VHF & UHF YAGI](#)

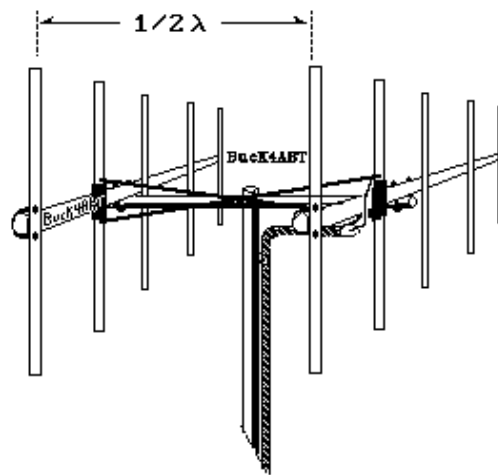

Two yagis, stacked $1/2$ wavelength apart
will render another 3 dB of gain.

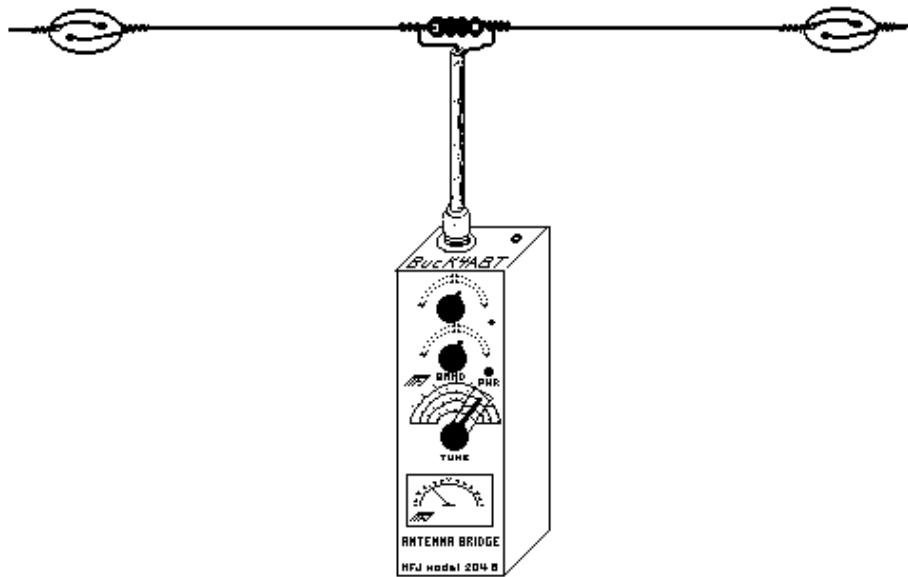

By using the "ANTENNA BRIDGE" the guess-work is
removed and the correct cable length and impedance
is sooner realized.

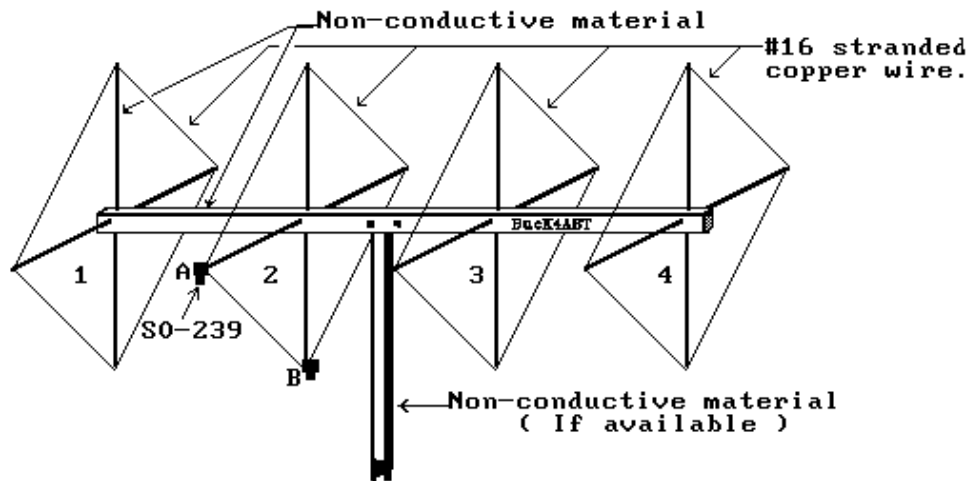

BASIC CONSTRUCTION OF A CUBICAL QUAD ANTENNA

The "QUAD", feed point "A" for vertical polarization. Feed point "B" for horizontal polarization. Element (1) is reflector, (2) is driven element, 3 & 4 are directors.

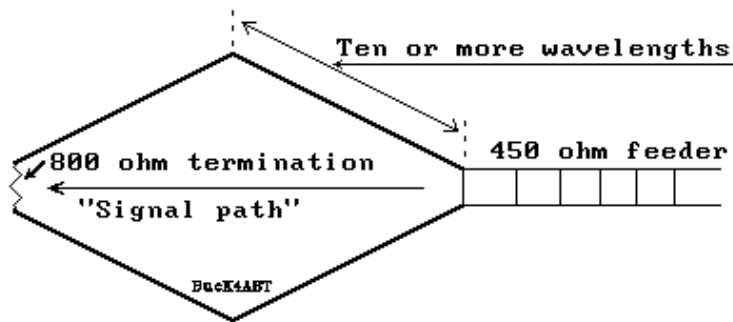

The "ROMBIC" is a highly directional and very high gain antenna. It also requires a large parcel of real-estate.

USE CAUTION when cutting steel rod and wear eye protection !!

Trunk Lip Mount

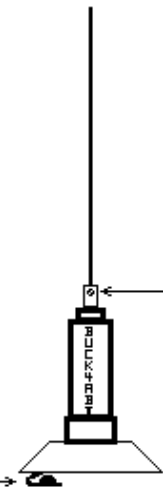

Loosen set screw and remove steel rod from base.

Remove portions of rod in 1/8" segments until VSWR is below 1.5 to 1.

Method used to modify some CB antenna for ten meter use. **NOTE: DO NOT over-tighten set screw.**

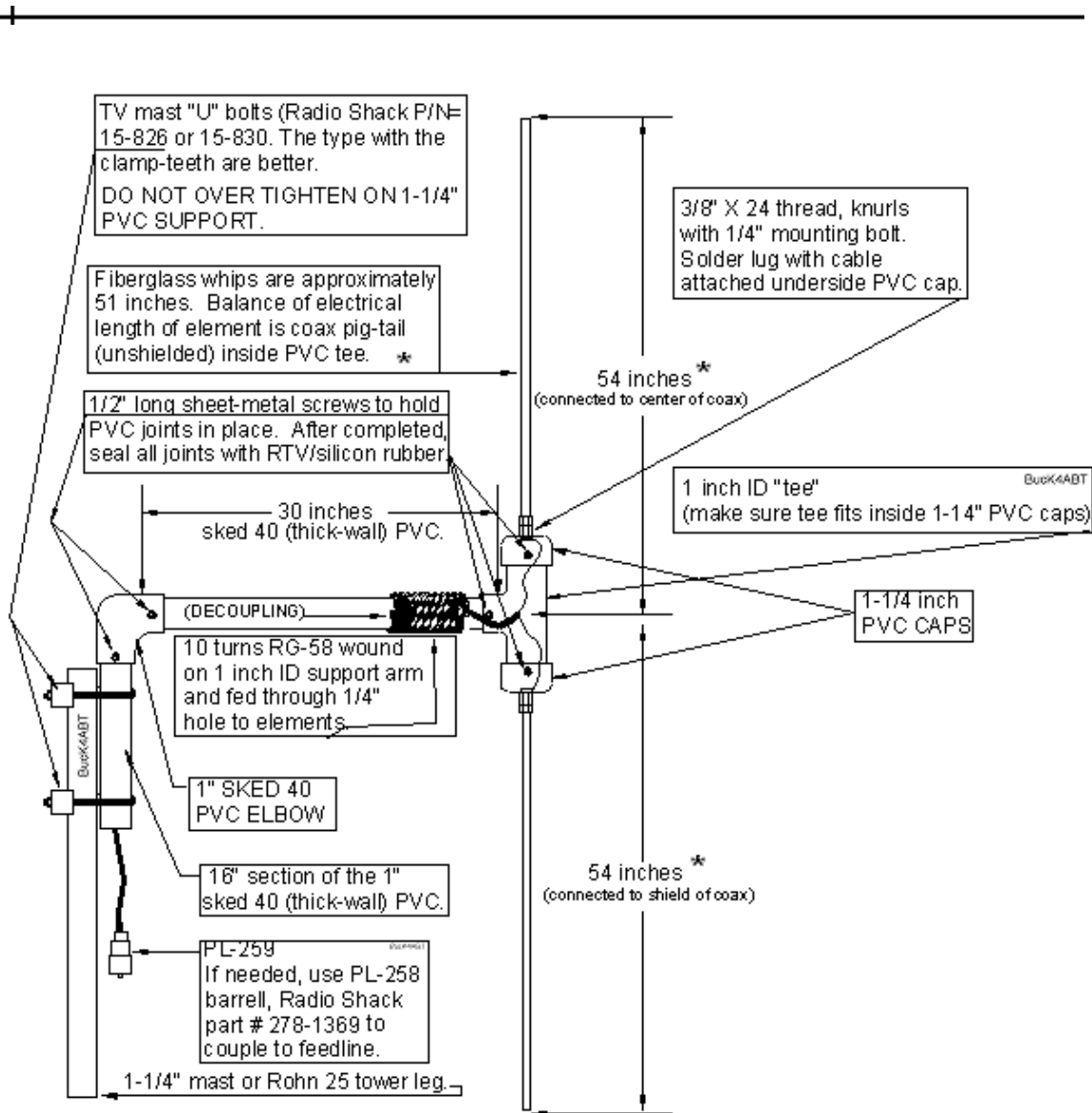

An improved "High-Performance" 6 meter Base-Station Dipole Antennas & Accessories

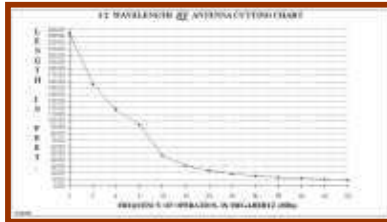

[CLICK ON the small graphic to view full size.](#)

Half-Wave HF Antenna Cutting Chart.

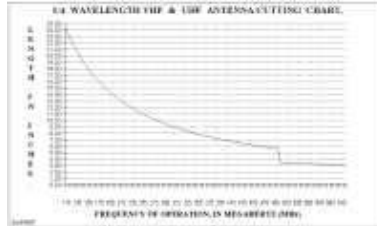

[CLICK ON the small graphic to view full size.](#)

VHF/UHF Cutting Chart

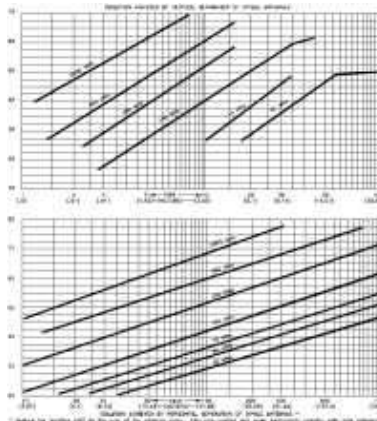

[CLICK ON the small graphic to view full size.](#)

Antenna Isolation / Spacing Charts



[HAM Radio and Commercial 2-way radio antennas](#)

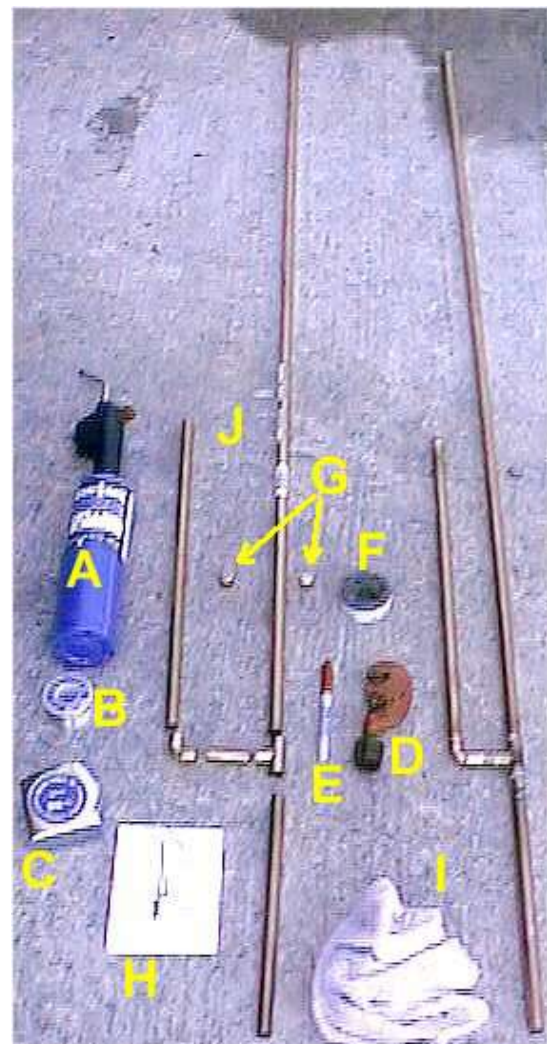
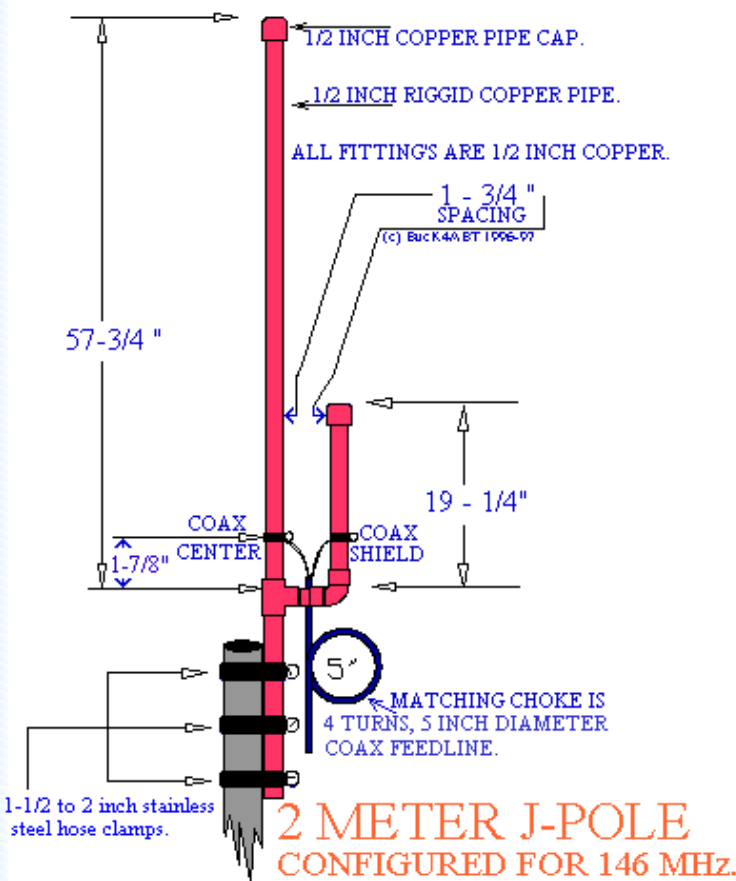
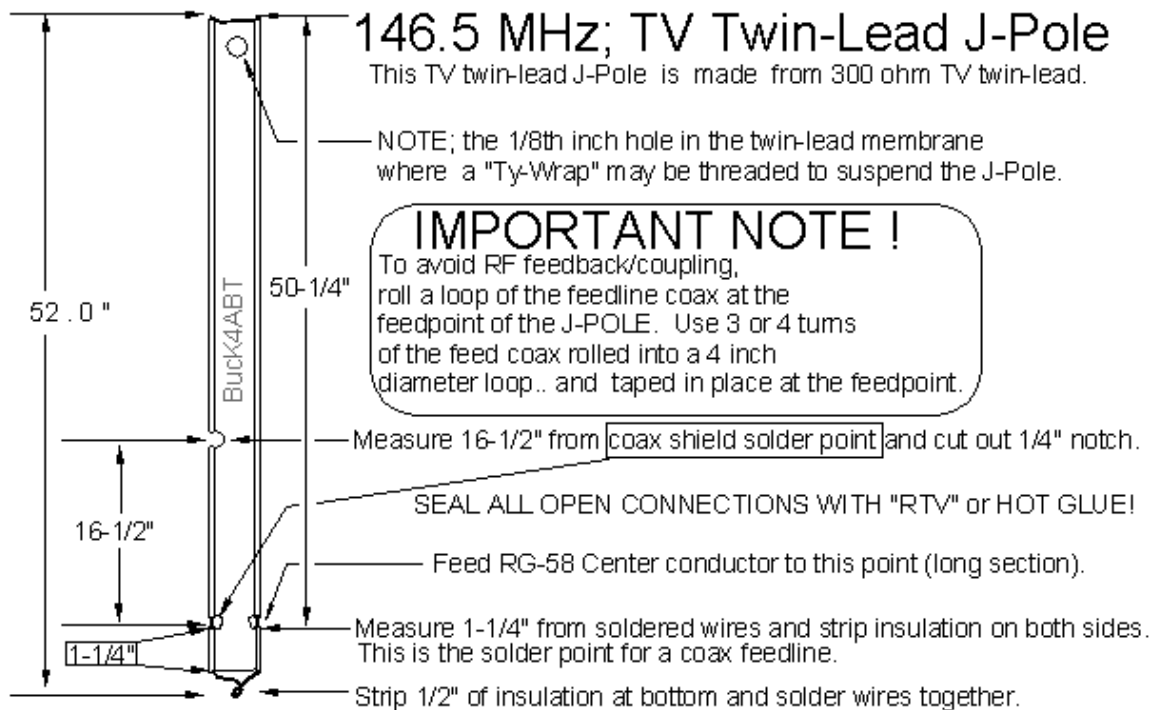

A=Benz-O-Matic propane torch; B=Lead-Free solder; C=Tape measure; D=Tubing cutter; E=Sharpie marking pen;

F=Solder Paste; G=1/2 inch copper caps; H=Hardcopy of the above drawing; I=Wet Towel; J=PreCut, ready to assemble parts of the 2 meter J-Pole.

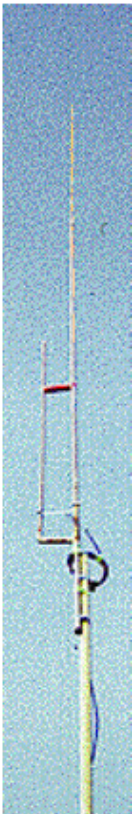
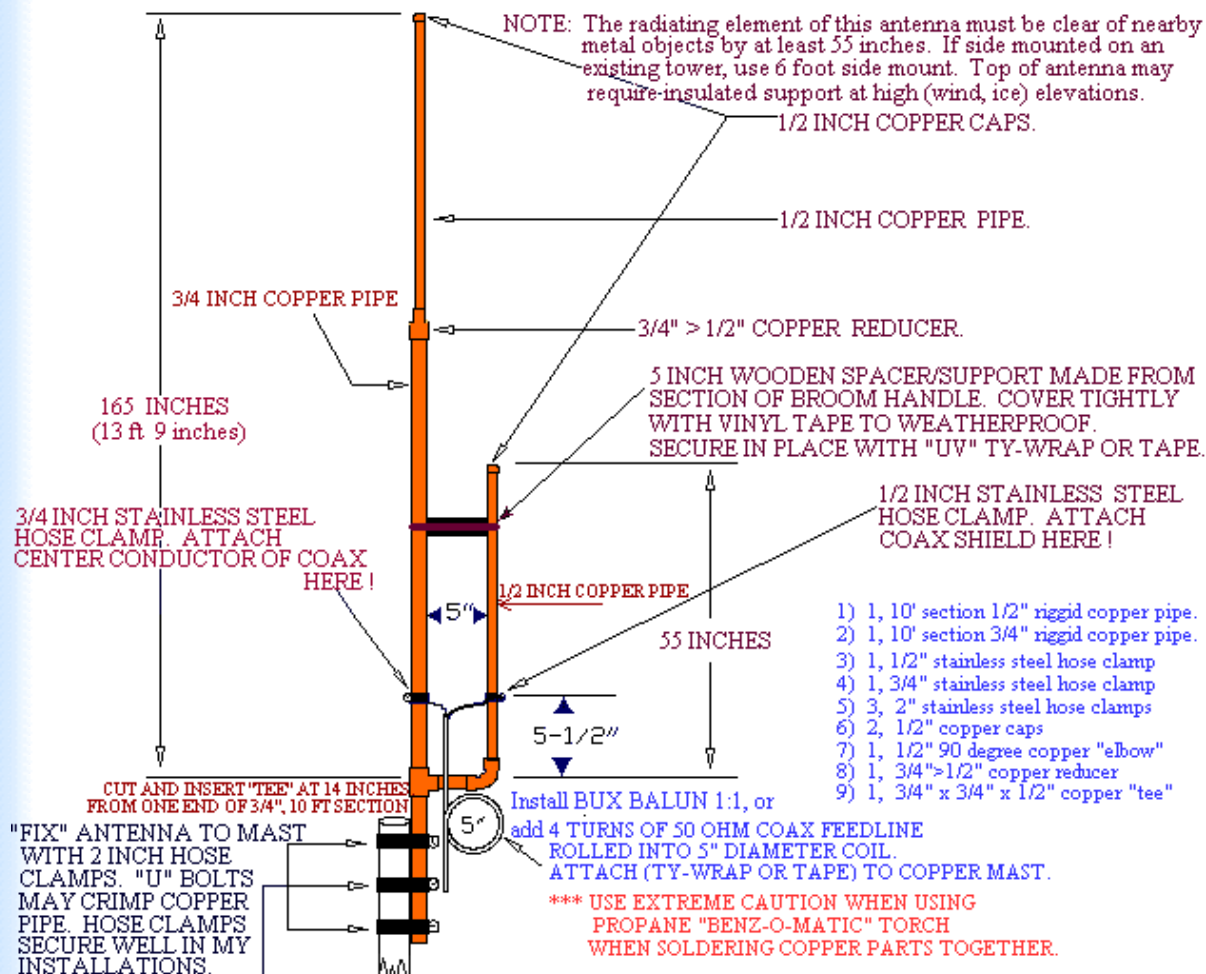

by Buck Rogers K4ABT
6 METER "J" POLE ANTENNA; DIMENSIONS ARE FOR 51 MHz

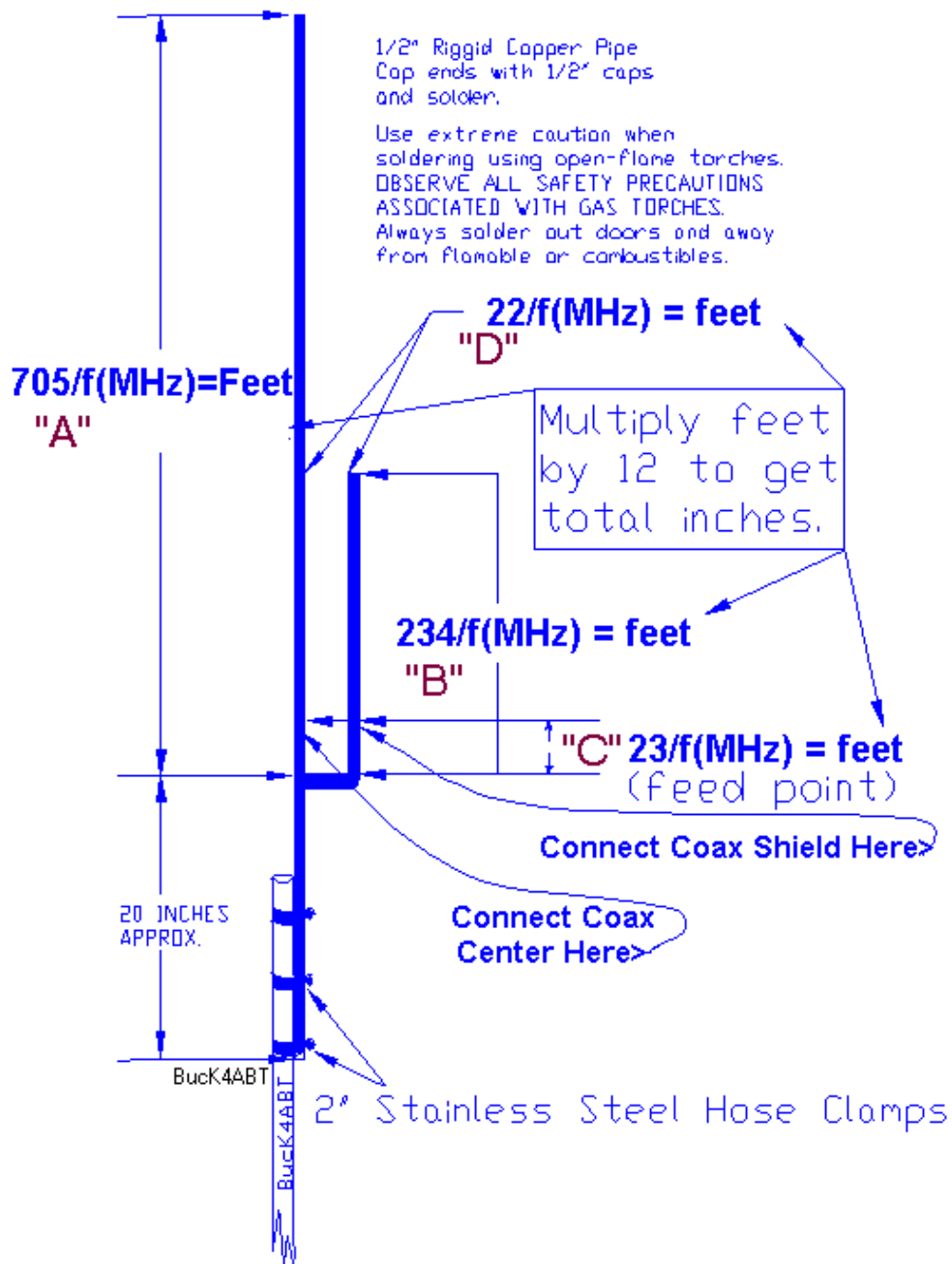

[CLICK HERE](#)  [AND DESIGN YOUR OWN "J" Pole](#)

Design-A-Quad Antenna

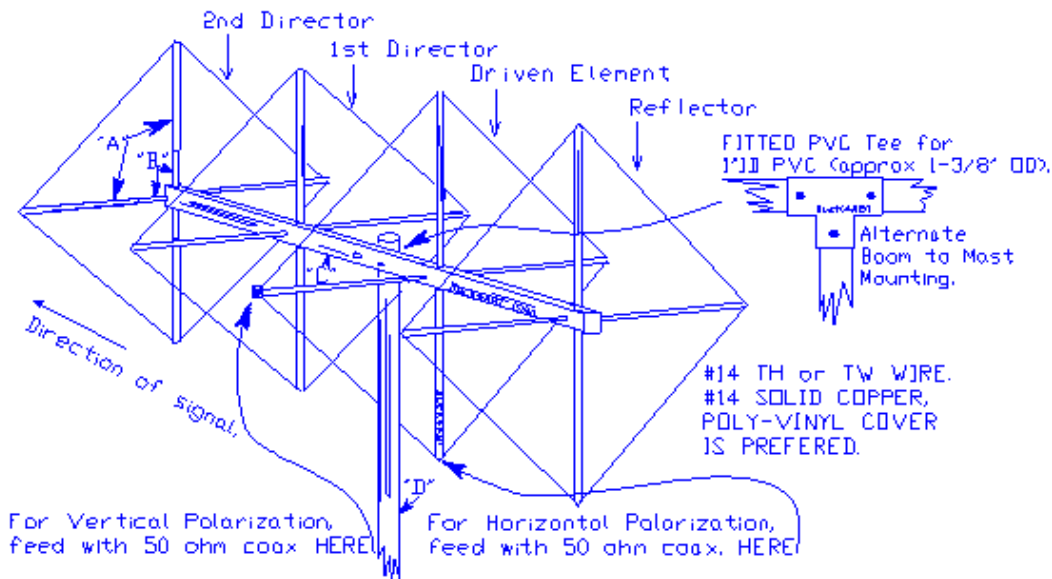

- *A* = 1/2" ID hot/cold PVC. PVC should fit securely over 1/2" OD wooden dowel *B*.
 - *B* = 1/2" OD wooden dowel 2 ft long through 1" ID boom. Dowel should extend approximately 9-1/2" out from each side of 1" ID boom. Fit 1/2" PVC (*A*) over dowel. Make sure spreader is long enough to support each wire element length as determined by the calculations below. Once PVC is in place over the wooden dowels, drill with small bit and use short wire or picture hanger nail to secure on the dowel. Hot glue may be used as an additional keeper over the wire or nail head.
 - *C* = Boom may be made from square fiberglass or from round PVC 1" ID. Boom is drilled with 1/2" bit at points where wooden dowels are to be inserted.
- NOTE: Make sure the vertical and horizontal dowel holes are drilled offset so the dowels will by-pass each other inside the boom. Drill dowels with 1/16" (or smaller) bit each side of boom and secure with small nail or wire to hold (centered) in place. BOOM is thick wall "Sked 40" 1" ID PVC.
- *D* = 1" ID (sked 40/Thick wall)PVC 48" long. Use "fitted" wooden dowel inside to make it more rigid and provide "body" to area where "U" bolts may be attached (rator head end to boom). See alternate boom mounting.

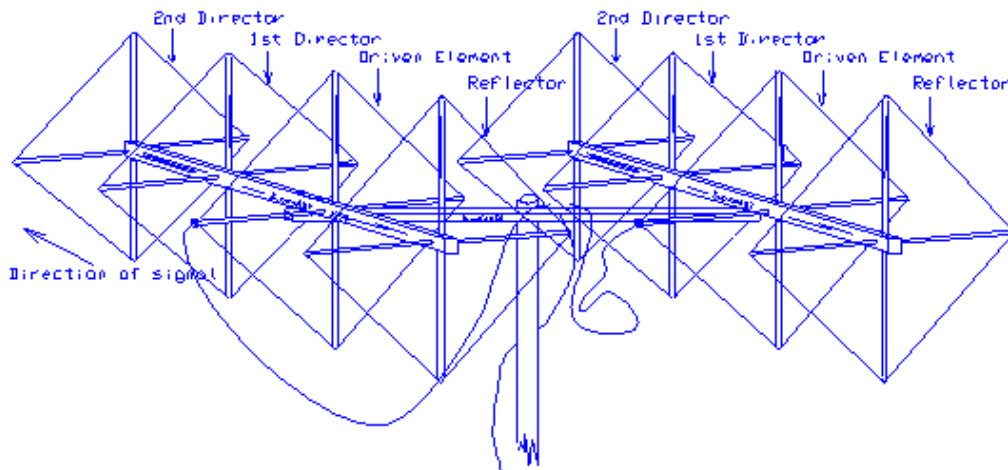

Horizontal "stacking" of quads will improve the signal strength by at least 3 DB. The QUAD's inherent immunity to terrestrial noise, makes it the ideal antenna (beam) for Packet Radio use.

Measurements and dimensions for the QUAD antenna are found using the QUAD design calculator below.

Calculate the total wire length for each element of a quad antenna.

$$\begin{aligned} \text{REFLECTOR} &= 1030 / F \text{ (MHz)} \\ \text{DRIVEN} &= 1005 / F \text{ (MHz)} \\ \text{DIRECTOR 1} &= 975 / F \text{ (MHz)} \end{aligned}$$

$$\text{DIRECTOR 2} = 960 / F \text{ (MHz)}$$

ELEMENT SPACING between:

- 1) Reflector & Driven Element = $730 / F$ (MHz)
- 2) Driven Element & 1st Director = $600 / F$ (MHz)
- 3) 1st Director & 2nd Director = $600 / F$ (MHz)

Enter the formula for the antenna calculation

Divided by Freq MHz

Total wire-length in feet is **FEET.**

Total wire-length in inches is **INCHES.**

One of four sides in FEET = <- Use **ONLY** this number for "element spacing" when entering the **element spacing** numbers (constants; 730 or 600) above!
Total all spacing measurements (in inches) then add 2 inches for each end.

THE QUAD SHOWN BELOW IS AN EXAMPLE OF A QUAD DESIGN USING **DESIGN-A-QUAD** ABOVE

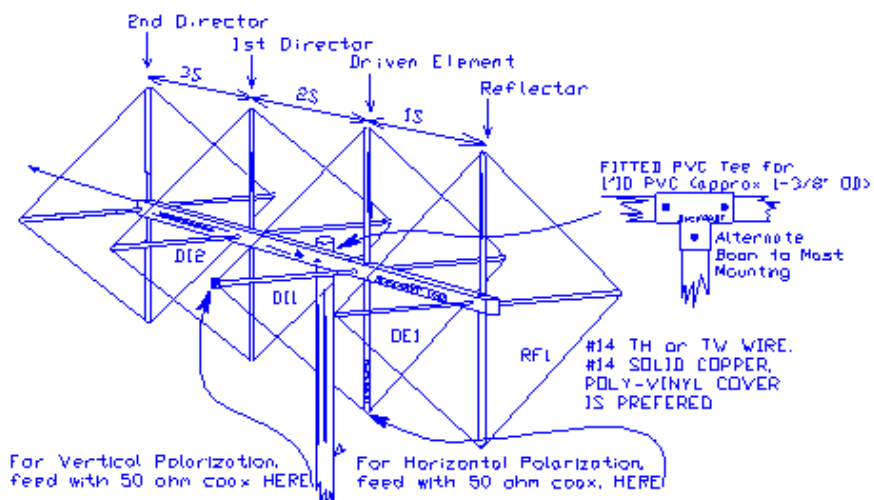

AN EXAMPLE OF A 4 ELEMENT, SIX METER QUAD

| | |
|----------------------------|--------------------|
| TOTAL ELEMENT WIRE LENGTHS | LENGTH OF ONE SIDE |
| RF1 = 241-3/4 INCHES | 60-1/2 INCHES |
| DE1 = 236-0" | 59-0" |
| DI1 = 229-0" | 57-1/4" |
| DI2 = 225-0" | 56-1/4" |

ELEMENT SPACING
 1S RF1 to DE1 = 43 INCHES
 2S DE1 to DI1 = 34 INCHES
 3S DI1 to DI2 = 34 INCHES
 ADD 2 INCHES AT EACH END
 TOTAL BOOM LENGTH = 115 INCHES

When stacking two of these quads, use 44 inch lengths of 75 OHM cable, from Coax "TEE" connector to each Quad. Coax from transmitter to "Tee" is 50 ohm coax. As viewed above, for vertical polarization, feed both quads as shown (left side). For Horizontal polarization, feed both quads at bottom of the driven element (as indicated).

ANTENNA INSULATORS

Weatherproof, (TENYTE) insulators. Perfect for your DIPOLE or Windom antenna.



For the apartment dweller, you can now hang the 20 meter doublet in the attic. I've QSO'd with stations all over the world with the 33 ft dipole in the attic of my garage. One insulator at the center, and one at each end.

It's great for other HF **WINDOM**, single, and multi-band dipole antennas. Dielectric strength is superior to the old ceramic insulators, without susceptibility to cracking or breakage under impact or extreme temperature changes.

Package of 3, \$2.99 ANTINSL3

[Order Now](#)

Package of 10, "TeNyte" BUX TNT Insulators \$8.99, ANTINSLX10

[Order Now](#)

For those who want lightning protection, here is one of many, lightning protection device.



A Secondary Lightning Protector

Remember the axiom; "**An ounce of prevention is worth a pound of cure.**" This lightning protector contains a modified spark gap that provides that ounce of prevention. We offer this device as a *secondary* radio protector. Remember, there is no substitute for a good earth ground, AC line surge, and spike protection.

Keep all ground leads as short as possible. Where lightning is involved, we make no warranties.

\$ 3.95 each 7516

[Order Now](#)

UHF DOUBLE FEMALE BULKHEAD (feed-thru) CONNECTORS

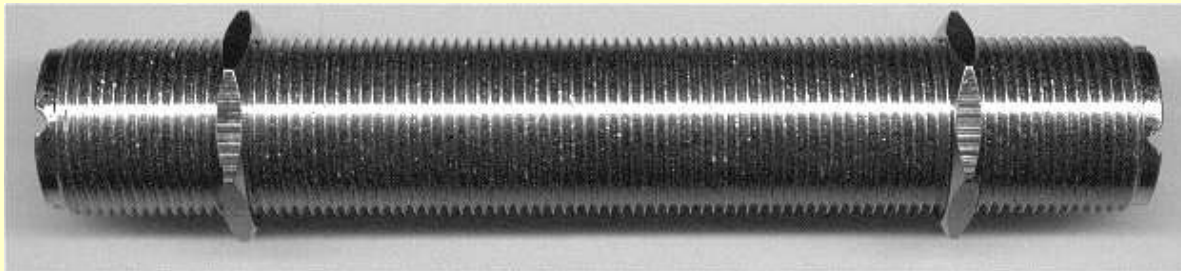

For bulkhead and through-the-wall UHF connector feed-thru connections, with keeper nuts.:

Order 7518-2 (Two inches)

\$ 2.95 ea.

[Order Now](#)

10 for \$ 24.50

[Order Now](#)

Order 7518-4 (Four inches)

\$ 3.95 ea.

[Order Now](#)

10 for \$ 34.50

[Order Now](#)

Order 7518-6 (Six inches)

\$ 4.95 ea.

[Order Now](#)

10 for \$ 44.50

[Order Now](#)

- | | | | |
|--|---|------------------|---|
| Order 7518-8 (Eight inches) \$ 8.95 ea. | Order Now  | 10 for \$ 82.50 | Order Now  |
| Order 7518-10 (Ten inches) \$ 10.95ea. | Order Now  | 10 for \$ 99.50 | Order Now  |
| Order 7518-12 (Twelve inches) \$12.95ea. | Order Now  | 10 for \$ 114.50 | Order Now  |

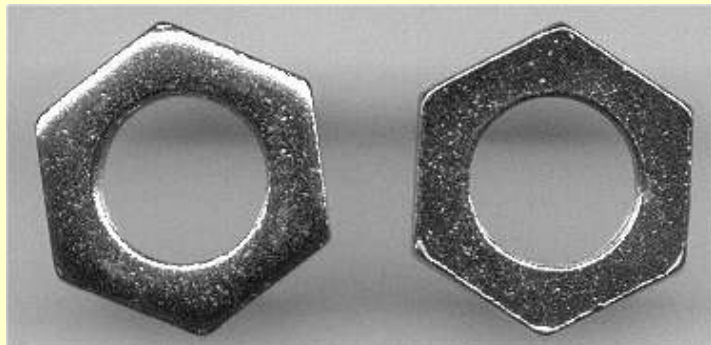



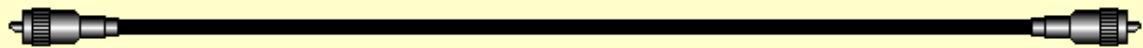

Heavy Duty (1") Nuts for the above bulkhead connectors.

- | | | | | |
|--------------------|-----------------|---|----------------|---|
| 2/.99 cents | HDM1-NUT | Order Now  | 10 for \$ 3.99 | Order Now  |
|--------------------|-----------------|---|----------------|---|



50 Ohm impedance, 3 ft, 6 ft, 9 ft, 12 ft, & 18 feet.

These jumpers are made from high quality, low-loss, RG8X coax cable WxTite, PL-259 connectors installed at each end.

- | | | | | |
|---------------------------|-----------|-----------|--------|---|
| <u>Three ft. (3')</u> | ORDER No. | 8X3-PLPL | \$3.95 | Order Now  |
| <u>Six ft. (6')</u> | ORDER No. | 8X6-PLPL | \$4.95 | Order Now  |
| <u>Nine ft. (9')</u> | ORDER No. | 8X9-PLPL | \$5.95 | Order Now  |
| <u>Twelve ft. (12')</u> | ORDER No. | 8X12-PLPL | \$7.95 | Order Now  |
| <u>Eighteen ft. (18')</u> | ORDER No. | 8X18-PLPL | \$8.95 | Order Now  |

[For more RF Connectors and communications site accessories; CLICK HERE !](#)

At BUX COMM, *We don't cut corners!

The components used in the manufacture of our BALUNS are from top quality components, beginning with the Silver Plate SO239 connectors. The center insulator is teflon™(E.I Dupont). The wire we use to wind the ferrite donut is heavy-duty, silver flashed wire, with teflon™ insulation that will handle RF voltages above 5000 volts, and temperatures above 2000 degrees. The binding posts are heavy-duty, tempered brass, with end holes and side-thru holes to accommodate either type loop-thru connection. A double-shoulder brass capture nut is used to add a secure bite and improve antenna wire electrical connections.



4:1 Balun, BUXBALUN 41 \$19.95 [Order Now](#)

- o 50 ohm, SO-239 unbalanced input
- o Balanced output
- o 1.6 to 50 MHz
- o Toroid (Voltage) design
- o Heavy Duty, Lightweight construction
- o Sealed against moisture

1:1 Balun, BUXBALUN 11 \$19.95 [Order Now](#)

- o 50 ohm, SO-239 unbalanced input
- o Balanced output
- o 1.6 to 50 MHz
- o Toroid (Current) design
- o Heavy Duty, Lightweight construction
- o Sealed against moisture

BUX UN UN De-Coupling transformer, similar to above, but has SO-239 (female) input connector and output connector is 1 ft Mini 8 cable with PL-259 (male).

BUX ONION \$19.95 [Order Now](#)

4:1, 1.5kw Balun, BUX BALUN 41HD \$27.95 [Order Now](#)

Toroid design, wound with teflon covered, silver plated wire.* Heavy-Duty, construction.

1:1, 1.5kw Balun, BUX BALUN 11HD \$27.95 [Order Now](#)

Toroid design, wound with teflon covered, silver plated wire.* Heavy-Duty, construction.

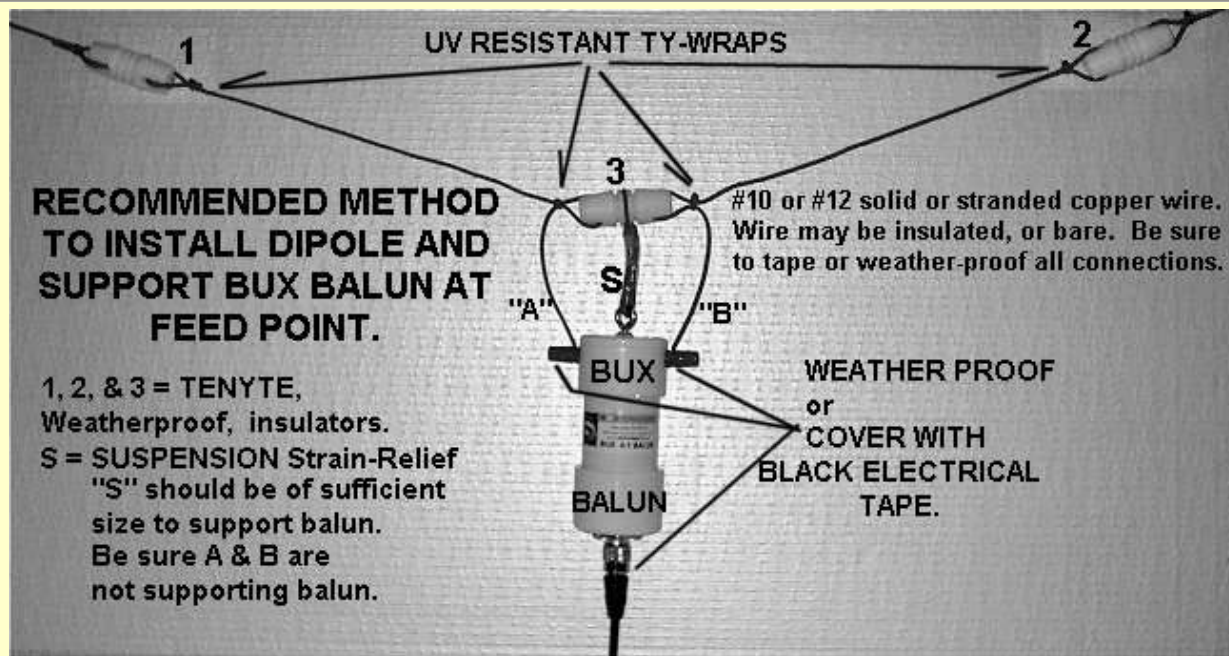

BUX COMM ©graphic



BUX MOBALUN

When you hear those strong HF mobile signals, here's one reason they stand out from the rest.

By installing the BUX MoBalun near the input to your antenna, you deliver more RF energy to the antenna. At the same time, the BUX MoBalun prevents RF from traveling back along the shield (high SWR) of your coax. High power rating, Low-permeability toroid, with Internal composition fiberglass to prevent vibration during mobile operation. For input and output connectors, we use only the best Silver

plated, Teflon insulated, SO239

connectors. 500 watts PEP. ***This MoBALUN is also ideal for marine antenna installations.***

BUX COMM ©Photo

\$19.95 MOBALUN

Order Now 

[CLICK HERE for Accessories, Antennas, Components, Connectors & Power cords](#)

Web Page Design and HTML By
G. E. 'Buck' Rogers Sr K4ABT d/b/a BUX CommCo™ ©
Copyright © 1996-2004 All Rights Reserved

FAX 434 525 7818



THE W5UN 2 METER QUAGI 97
Issue 2, July 17, 1997

The W5UN Quagi 97 is a computer optimized quagi derived from the original W5UN Quagi of the early 1980s. The length of the 1997 model has been deliberately shortened to allow it fit on a 24 foot boom. Performance is substantially higher than that of the original antenna. It now compares favorably with yagis of the same length. The two programs used to optimize the updated antenna were AO6 and NEC 2.

This antenna has not been verified by actual construction. Gain and front to back will be as stated below. The only component of the antenna that needs verification is the 50 ohm match. *Who would like to be the FIRST to build the actual prototype model??* Full consultation will be available to the prototype builder during construction. Contact w5un@wt.net if you wish to be the first!

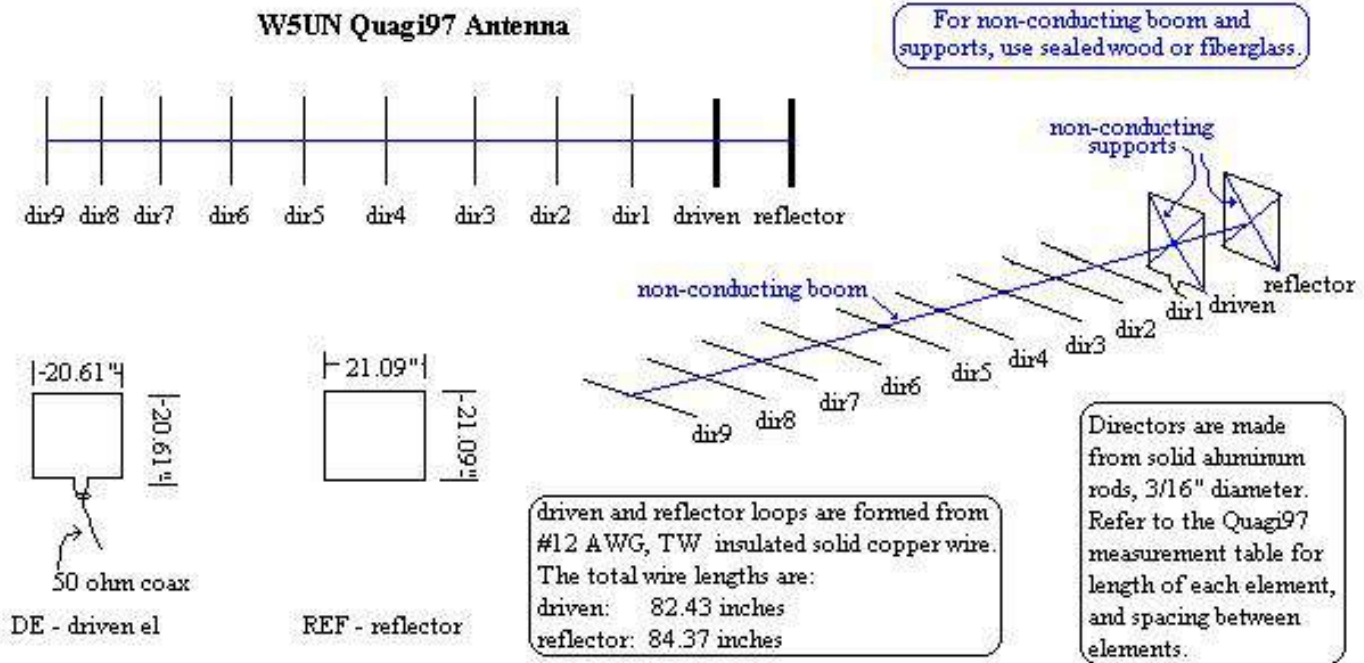

Antenna Characteristics:

23' 9"

11 Element Gain: 13.56 dBd at 144.100 Mhz

F/B : 23 dB Stacking: Optimum: E Plane: 13.73'

Optimum: H Plane: 12.86'

Stacking can be reduced up to 90 percent of optimum and still achieve acceptable stacking gain. Optimum stacking is recommended, however. W5UN QUAGI 97 Dimensions in FREE SPACE:

| Element | Boom Pos. | El. Length | Material |
|-----------|-----------|--------------|-----------------------------------|
| Reflector | 0.0000" | 84.37" loop. | #12 solid INSULATED copper wire * |
| Driven | 16.2500" | 82.43" loop. | #12 solid INSULATED copper wire * |
| Dir 1 | 37.1875" | 36.168" | 3/16" aluminum rod |
| Dir 2 | 70.1875" | 36.052" | 3/16" aluminum rod |
| Dir 3 | 102.5000" | 35.817" | 3/16" aluminum rod |
| Dir 4 | 135.8125" | 35.475" | 3/16" aluminum rod |
| Dir 5 | 169.0625" | 35.179" | 3/16" aluminum rod |
| Dir 6 | 202.8125" | 35.090" | 3/16" aluminum rod |
| Dir 7 | 234.2500" | 35.324" | 3/16" aluminum rod |
| Dir 8 | 264.8750" | 35.617" | 3/16" aluminum rod |

Dir 9 285.0000" 35.108" 3/16" aluminum rod

* #12 TW insulated solid copper wire is common house wire, found at most hardware and building supply stores. Do not strip the insulation.

The above dimensions may be used for non metallic booms like wood or fiberglass.

If you wish to use a metal boom with through the boom insulated elements, please apply the following correction to the directors only. The reflector and driven quad elements must remain insulated from the boom.

| Boom Diameter | Correction | Add |
|--------------------|------------|-------------------|
| 0.750" or 19.050MM | 10.56% | .0792" or 2.02MM |
| 0.875" or 22.225MM | 12.14% | .1062" or 2.70MM |
| 1.000" or 25.400MM | 13.66% | .1366" or 3.47MM |
| 1.125 or 28.575MM | 15.13% | .1702" or 4.32MM |
| 1.250" or 31.750MM | 16.54% | .2068" or 5.25MM |
| 1.375" or 34.925MM | 17.90% | .2462" or 6.25MM |
| 1.500" or 38.100MM | 19.21% | .2882" or 7.32MM |
| 1.750" or 44.450MM | 21.67% | .3792" or 9.63MM |
| 2.000" or 50.800MM | 23.91% | .4783" or 12.15MM |

(End of Table)

Further information concerning use of metallic booms with insulated 'thru-the boom' mounted elements follows:

**PROVEN ACCURATE FOR BOOM DIAMETERS SMALLER THAN .055 WAVELENGTHS.
MEASUREMENTS BY DL6WU.FORMULA BY G3SEK.**

FORMULA: $C = 12.5975B - 114.5B^2$
C = CORRECTION FACTOR AS A FRACTION OF THE BOOM DIA.
B = BOOM DIA IN WAVELENGTHS
B^2 MEANS B SQUARED

2 METERS
BOOM DIAMETER CORRECTION ADD
2 METERS.

0.750" OR 19.050MM 10.56% .0792" OR 2.02MM
0.875" OR 22.225MM 12.14% .1062" OR 2.70MM
1.000" OR 25.400MM 13.66% .1366" OR 3.47MM
1.125 OR 28.575MM 15.13% .1702" OR 4.32MM
1.250" OR 31.750MM 16.54% .2068" OR 5.25MM
1.375" OR 34.925MM 17.90% .2462 OR 6.25MM
1.500" OR 38.100MM 19.21% .2882" OR 7.32MM
1.750" OR 44.450MM 21.67% .3792 OR 9.63MM
2.000" OR 50.800MM 23.91% .4783" OR 12.15MM

20.000MM 11.04% 2.21MM
28.000MM 14.87% 4.16MM
30.000MM 15.78% 4.73MM
32.000MM 16.66% 5.33MM
38.000MM 19.17% 7.29MM

Insulators can be commercial shoulder insulators and keepers or as simple as

heat shrink tubing with the element held in place by hot melt glue or epoxy glue.

The Quadix

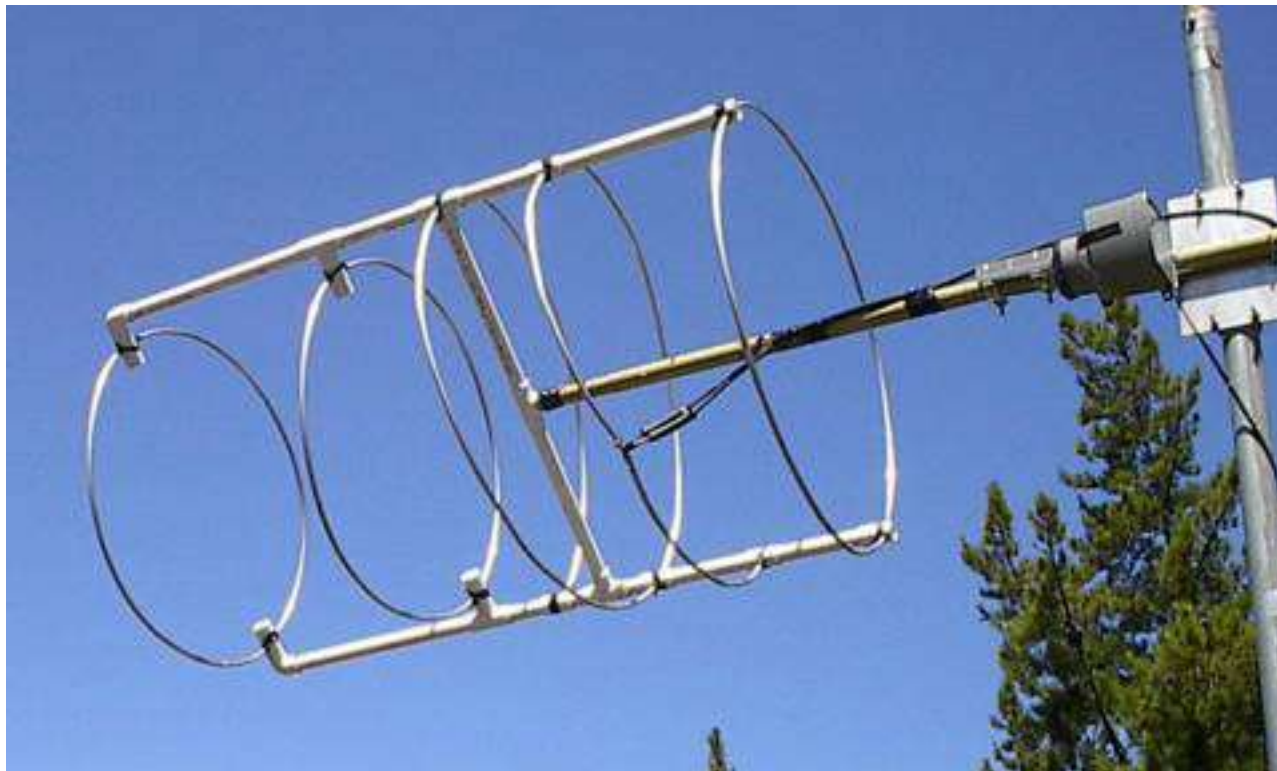

The Quadix is a circularly polarized parasitic array, a hybrid between a helix and a quad (or loop yagi). As is the case with other yagi type parasitic arrays, it has a reflector and as many directors as desired. A two turn helix is used as the driven element. The helix is driven $\frac{1}{4}$ turn from the end of the helix closest to the reflector. Its impedance is a nearly constant 300 ohms across a wide band for a conductor size of $\frac{3}{8}$ inch. As with off center fed antennas, the feed point is not balanced, so a current balun is required. A tv/fm balun works well. Or there are many other balun possibilities (see below). I will now describe a 4 element 2 meter quadix.

Its bandwidth exceeds 144 – 148 MHz. Over the 144 – 148 MHz band, its free space gain is simulated to be about 10.5 dBi, and axial ratio less than 2 dB. The SWR is measured to be less than 1.2 when used with an innovative 300 ohm to 50 ohm balun transformer (described below), and axial ratio measured to be less than approximately 1 dB across the repeater output band 145.2 – 147.4 MHz, the source of my test signals.

The support structure is made from $\frac{3}{4}$ inch PVC pipe.

1 1/2

1 1/2

The elements are made of 3/8 inch aluminum refrigerator tubing, obtained locally (Sunnyvale, California) from Orchard Supply Hardware. If aluminum refrigerator tubing is not available, you can use copper refrigerator tubing.

The total length of the helix driven element is 179 3/4 inches. Mark it at 44 15/16 inch intervals to show where it passes through the PVC pipe. Also mark it 22 1/2 inches from one end. This will be where the balun is attached. The total length of the reflector will be 89 9/16 inches. The total length of the directors is 76 3/16 inches. Mark each of them at the halfway point.

Before assembling the antenna, temporarily connect the ends of each of the elements together and shape them into circles. The driven element should be shaped into a two turn circle.

Assemble the antenna by feeding the elements through the holes drilled in the PVC assembly. The ends of the directors and reflector can be connected together by flattening and securing with bolts, by slotting one end and squishing it down to fit into the other end and securing with a bolt, or by fitting a sleeve over the two ends and securing with a pipe clamp. If one of the overlap methods is chosen, don't forget to allow for this when cutting the tubing.

Before assembling the helix driven element, cut out a ½ inch section of tubing at the feed point and replace by an insulating material. An insulator fashioned from a piece of PVC coupling works well. For right hand circular polarization, feed the helix clockwise through the holes in the PVC assembly as shown in the picture. Secure the elements to the PVC structure. Connect the antenna to a boom, and the balun and feed line to the antenna, and you are ready to go. If you want to measure the axial ratio against a friend's linear polarized signal (or local repeater signals), you need to attach a small rotator to the boom.

A 300 ohm to 50 ohm quarter wave balun transformer that is simple to make is shown.

It consists of a quarter wave transformer made from RG-58 and RG-59 in series. The impedance of the quarter wave transformer is 53 plus 73 equals 126 ohms, which transforms 300 ohms to 53 ohms. The balun action comes from the fact that the two sides of the 126 ohm transmission line (the center conductors of the coaxes) are isolated from each other. The balun is improved by putting approximately 8 ferrite beads onto each line. It has been pointed out to me by BB that there should be a few beads also on the 50 ohm line near where it connects to the balun.

Ross Anderson W1HBQ July 5, 2002 April 19, 2004

E-mail me at ross_anderson@comcast.net

Notes and References:

Kraus, Antennas, second edition, chapter 7, "The Helical Antenna".

Maxwell, "Some Aspects of the Balun Problem"

<http://home.iag.net/~w2du/Reflections2Chapter21SomeAspectsoftheBalunProblem.pdf>

Belrose, "The Off-Center-Fed Dipole Revisited: A Broadband, Multiband Antenna"

<http://www2.arrl.org/members-only/tis/info/pdf/9008028.pdf>

Belrose, "Transforming the Balun", QST, June 1991, pp 30-33.

Rosser, "Use Low-Loss 'Window' Ladder Line for Your 2-Meter Antenna", The ARRL Antenna Compendium, Vol 6, pp 165-167.

The beads I used were FB-43-5622. http://www.amidon-inductive.com/associates_prod_largerbeads.htm

My homepage “Ross’s Antennas” with links to my other pages .

http://home.comcast.net/~ross_anderson

SLIM-JIM 2m ANTENNA

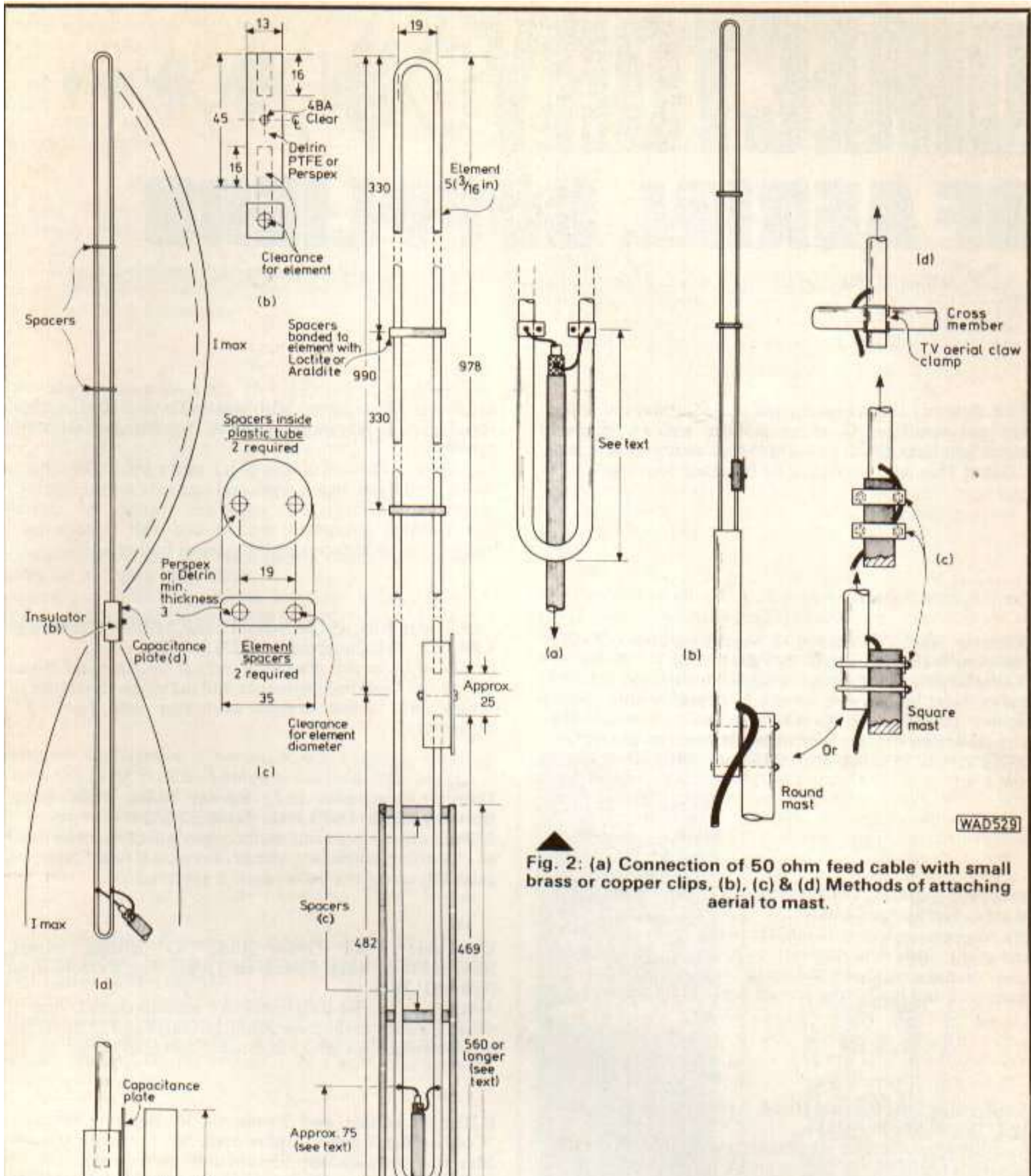

Fig. 2: (a) Connection of 50 ohm feed cable with small brass or copper clips. (b), (c) & (d) Methods of attaching aerial to mast.

WA0529

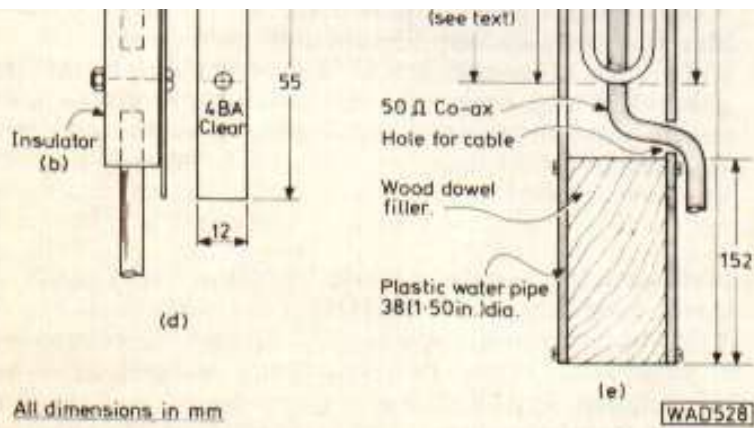

Fig. 1: (a) General configuration showing voltage and current distribution. (b) Details of capacity plate insulator. (c) Spacer details. (d) Capacity plate details. (e) General view including details of final enclosure in plastics tube.

THE SPERRTOPF ANTENNA FOR THE TWO-METER BAND
 By ON4CFC, Pascal Veeckmans ~ Translation by Jef Verborgt



To read the PDF, you must have **Adobe Acrobat Reader 4.0** installed to download and read the article. If you don't have Acrobat Reader **4.0** installed, it's available free for download at <http://www.adobe.com/acrobat>

Due to the complexity of this article, we have chose to present it in PDF form. Although the loading is a little slower (overall), some of the many advantages of the PDF format is it contains all of the article's intended formatting allowing **proper printing** of the article as seen on the screen. Further, it has the **fonts embedded** into the article, especially important when using a character set that may not be on the reader's computer, such as the **Greek symbols** used for equations. So, the reader can **save and print** the PDF article totally intact exactly as it was originally intended.

Other important features are, with Acrobat Reader, the reader can **magnify** (zoom in or out) the article to many different levels so that those superscripts or subscripts can be seen with total clarity. And if the reader wants to, the article can be **rotated** making it easy to view diagrams from different angles!

For those who have slower Internet connections, or prefer, we have also provided a copy of the PDF article in a compressed ZIP file. The file is much smaller and will take less time to download. Also, you will be viewing the article from your hard disk and navigation of the article will be faster than over the Internet. Further, for those who choose to load the PDF online, you may also save it to hard disk and view offline as well. To unzip the ZIP file, you need a program like **WinZip** or comparable available for free trial download at: www.winzip.com

~ Download Article ~

THE SPERRTOPF ANTENNA FOR THE TWO-METER BAND

View PDF Versions Below

For Fast Connections
 View online and print/save

>> [View PDF Online](#) << (339kb)

For slower connections or by choice
 Download "Zip" PDF file and view offline
 (Then unzip using WinZip or similar program)

>> [View PDF Offline in ZIP file](#) << (319kb)

Having problems? Check the [PDF FAQ](#) for some help.

~ Thanks and enjoy! ~

Remember, for PDF you must have Acrobat Reader 4.0 installed - Earlier versions will not view properly! To check for the version, launch Acrobat Reader, open "Help" and then look at "About" to see your version.

Cheap Yagi Antennas for VHF/UHF

by Kent Britain, WA5VJB
edited by John Maca, AB5SS

[Home](#)

[Announcements](#)

[APRS](#)

[By-Laws](#)

[Calendar](#)

[Club Info](#)

[Contesting](#)

[Dates VE and
Club meetings](#)

[Non CLARC VE
exams](#)

[Events](#)

[Field Day](#)

[HAM CLASSES](#)

[Ham Fest](#)

[History](#)

[List Servers](#)

[Local Nets](#)

[Memberships](#)

[News Letters](#)

[Order Products](#)

[Other ARRL TX
Hamfests](#)

[Other TX
Hamfests](#)

[Public Service](#)

[Repeater](#)

[Roster](#)

[Editors notes: The antennas described in this article were built as the result of several discussions between Kent and a Cuban radio operator. While there are plenty of high performance antenna designs, most of the parts required to build them are not available in Cuba. There just isn't an EPO or Radio Shack available in Cuba. Kent accepted this as a challenge to design a really good antenna that could be built with little more than ground wire, coax and a wooden boom. Using the latest antenna design software, he has developed several variations for 144 thru 1296 MHz. Apparently, the designs work very well... Kent entered the 432 MHz version in a recent antenna contest and lost by 0.2 dB to a Midwest ham who had copied his design. Though disappointed in losing, it did prove to Kent that the antennas can be easily replicated with consistent performance.]

If your planning to build an EME array, don't use these antennas. But, if you want to put together a Rover station with less than \$500 in the antennas or just want a good antenna for the home, read on.

These antennas are relatively small, easily constructed from common materials/tools and have surprising performance. The feed method is greatly simplified by directly soldering the coax to the driven element. No baluns or gamma matches are used in this design. This simplified feed uses the structure of the antenna itself for impedance matching. The spacing of the director and reflector elements from the driven element directly affects the feed point impedance of the antenna. So, the design starts with the feed (driven element) and the elements are built around it. Typically, a high gain antenna is designed in the computer, then you try to come up with a matching arrangement for a 31.9 Ohm feed! For the cost about 0.5 dB of gain, these antennas make some design compromises for the feed impedance, use an asymmetrical feed and make trade offs for a very clean pattern. But, they allow simple measurements, have wide bandwidth, the ability to grow with the same element spacing AND... you can build these antennas for \$5!!!!

The booms used for these antennas is 1/2" X 3/4" wood. The elements have been made from silicon bronze welding rod, aluminum rod, hobby tubing and solid ground wire with no change in performance. Since you want to be able to solder to the driven element, silicon bronze welding rod, hobby tubing and #10 or #12 solid copper wire have been used and work fine. A drop of "Super Glue", epoxy or RTV is used to hold the elements in place. A good coat of Polyurethane should be applied to the wooden boom to protect it from the weather. A polyurethane varnished 902 MHz version has been in the air for a year now with little deterioration in performance.

And now for the antenna designs. These antennas have been carefully designed to have the highest dB's/Dollar ratio of anything around They were designed with YagiMax, tweaked using NEC and the driven elements experimentally determined on the antenna range. The driven element design is the same for all frequencies except for the length (L) and separation (H). See Figure 1 for details on the driven element. All dimensions are in inches.

Driven Element Construction (all versions)

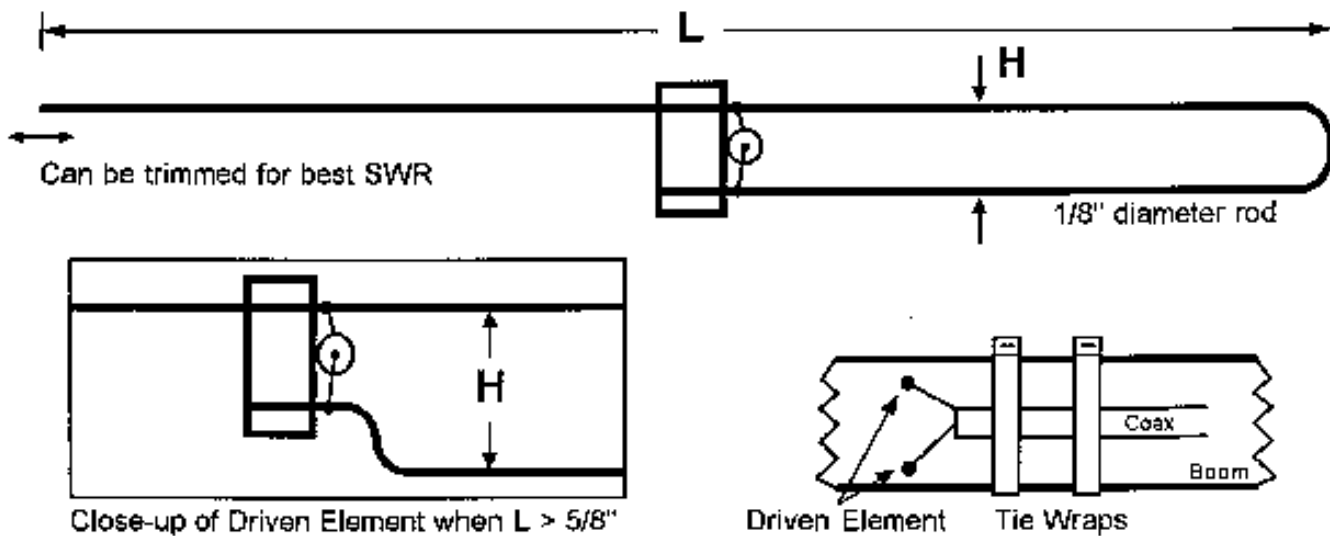

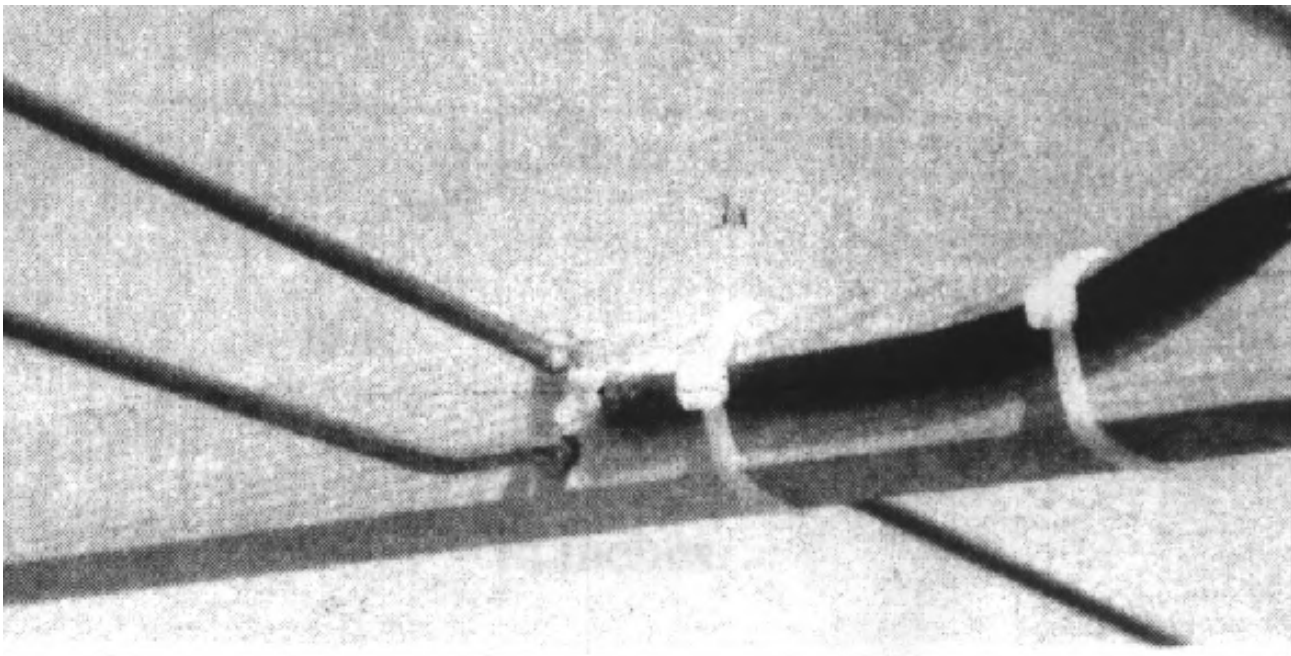

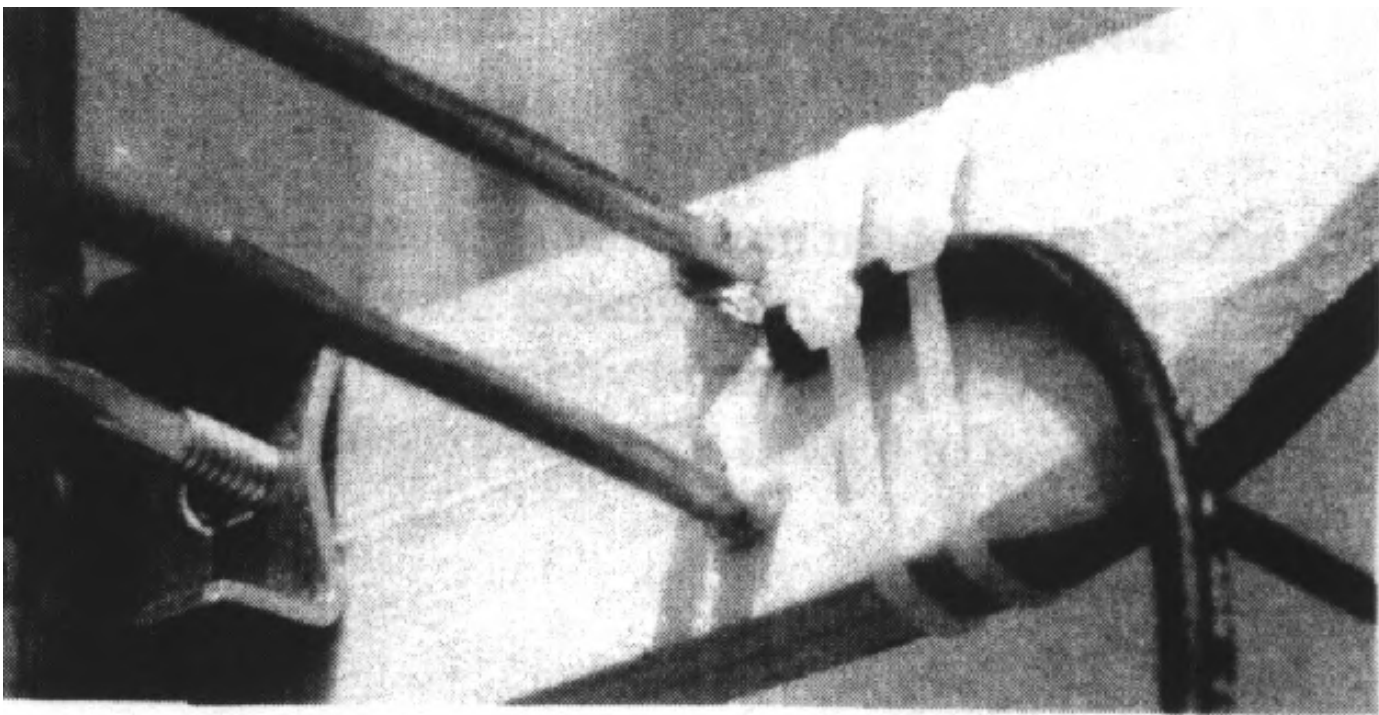

144 MHz. This antenna is peaked for 144.2 MHz but performance is still good at 146.52 (emergency use only!) Driven element dimensions are L = 38.5" and H = 1.0" Elements are 1/8" diameter.

| 144 MHz | | REF | DE | D1 | D2 | D3 | D4 |
|-----------|----------|-------|------|-------|-------|-------|-------|
| 3 Element | Length | 41.00 | | 37.00 | | | |
| | Spacing | 0.00 | 8.50 | 20.00 | | | |
| 4 Element | Length | 42.00 | | 37.50 | 33.00 | | |
| | Spacing | 0.00 | 8.50 | 19.25 | 40.50 | | |
| 6 Element | Length | 40.50 | | 37.50 | 36.50 | 36.50 | 32.75 |
| | Spacking | 0.00 | 7.50 | 16.50 | 34.00 | 52.00 | 70.00 |

222 MHz. This antenna is peaked for 222.1 MHz but performance bearily changes at 223.5 MHz. Driven element dimensions are L = 24.5" and H = 1.0" Elements are 3/16" diameter.

| 222 MHz | | REF | DE | D1 | D2 | D3 | D4 |
|-----------|---------|-------|------|-------|----|----|----|
| 3 Element | Length | 26.00 | | 23.75 | | | |
| | Spacing | 0.00 | 5.50 | 13.50 | | | |

| | | | | | | | |
|-----------|---------|-------|------|-------|-------|-------|-------|
| 4 Element | Length | 26.25 | | 24.10 | 22.00 | | |
| | Spacing | 0.00 | 5.00 | 11.75 | 23.50 | | |
| 6 Element | Length | 26.25 | | 24.10 | 23.50 | 23.50 | 21.00 |
| | Spacing | 0.00 | 5.00 | 10.75 | 22.00 | 33.75 | 45.50 |

432 MHz. This antenna is peaked for 432.1 MHz. At this frequency, this antenna is getting very practical and easy to build. Driven element dimensions are L = 13.0" and H = 3/8" Elements are 1/8" diameter.

| 432MHz | | REF | DE | D1 | D2 | D3 | D4 | D5 | D6 | D7 | D8 | D9 |
|------------|---------|-------|------|-------|-------|-------|-------|-------|-------|-------|-------|-------|
| 6 Element | Length | 13.50 | | 12.50 | 12.00 | 12.00 | 11.00 | | | | | |
| | Spacing | 0.00 | 2.50 | 5.50 | 11.25 | 17.50 | 24.00 | | | | | |
| 8 Element | Length | 13.50 | | 12.50 | 12.00 | 12.00 | 11.00 | 12.00 | 11.25 | | | |
| | Spacing | 0.00 | 2.50 | 5.50 | 11.25 | 17.50 | 24.00 | 30.75 | 38.00 | | | |
| 11 Element | Length | 13.50 | | 12.50 | 12.00 | 12.00 | 12.00 | 12.00 | 12.00 | 11.75 | 11.75 | 11.00 |
| | Spacing | 0.00 | 2.50 | 5.50 | 11.25 | 17.50 | 24.00 | 30.75 | 38.00 | 45.50 | 53.00 | 59.50 |

902/903 MHz. This was the first antenna I built using the antenna to control the driven element impedance. The 2 1/2' length has proven practical, so I haven't built any other versions. Driven element dimensions are L = 5.7" and H = 1/2" Elements are 1/8" diameter.

| 902/903 MHz | | REF | DE | D1 | D2 | D3 | D4 | D5 | D6 | D7 | D8 |
|-------------|---------|------|------|------|------|------|-------|-------|-------|-------|-------|
| 10 Element | Length | 6.20 | | 5.60 | 5.50 | 5.50 | 5.40 | 5.30 | 5.20 | 5.10 | 5.10 |
| | Spacing | 0.00 | 2.40 | 3.90 | 5.80 | 9.00 | 12.40 | 17.40 | 22.40 | 27.60 | 33.00 |

1296 MHz. This antenna is the veteran of several "Grid Peditions" but I have yet to actually measure the gain. Dimensions must be followed with great care. The driven element is small enough to allow 0.141 semi-rigid coax to be used instead of RG-58. Silicon Bronze welding rod was used for the elements but any material can be used. Driven element dimensions are L = 4.0" and H = 1/2" Elements are 1/8" diameter.

| 1296 MHz | | REF | DE | D1 | D2 | D3 | D4 | D5 | D6 | D7 | D8 |
|------------|---------|------|------|------|------|------|------|-------|-------|-------|-------|
| 10 Element | Length | 4.30 | | 3.90 | 3.80 | 3.75 | 3.75 | 3.65 | 3.60 | 3.60 | 3.50 |
| | Spacing | 0.00 | 1.70 | 2.80 | 4.00 | 6.40 | 8.70 | 12.20 | 15.60 | 19.30 | 23.00 |

OTHER VERSIONS

421.25 MHz ATV. 421 MHz Vestigial Sideband video is popular in North Texas for receiving the FM video repeaters. The driven element for these antennas is designed for an impedance of 75 ohms. So RG-59, or an 'F' adapter to RG-6, can be directly connected to a cable TV converter/Cable Ready TV on channel 57. Driven element dimensions are L = 13.0" and H = 1/2" Elements are 1/8" diameter.

Spacing is the same for all versions.

| 421 MHz ATV | | REF | DE | D1 | D2 | D3 | D4 | D5 | D6 | D7 | D8 | D9 |
|-------------|---------|-------|------|-------|-------|-------|-------|-------|-------|-------|-------|-------|
| 6 Element | Length | 14.00 | | 12.50 | 12.25 | 12.25 | 11.00 | | | | | |
| 8 Element | Length | 14.00 | | 12.50 | 12.25 | 12.25 | 12.00 | 12.00 | 11.25 | | | |
| 11 Element | Length | 14.00 | | 12.50 | 12.25 | 12.25 | 12.00 | 12.00 | 12.00 | 11.75 | 11.75 | 11.50 |
| | Spacing | 0.00 | 3.00 | 6.50 | 12.25 | 17.75 | 24.50 | 30.50 | 36.00 | 43.00 | 50.25 | 57.25 |

450 MHz FM. Yea, I understand it's FM, but sometimes a newcomer needs a cheap antenna to get into a repeater or give you a simplex QSO during a contest. Driven element dimensions are L = 12.0" and H = 3/8" Elements are 1/8" diameter. Spacing is the same for all versions.

| 450 MHz FM | | REF | DE | D1 | D2 | D3 | D4 |
|------------|---------|-------|------|-------|-------|-------|-------|
| 6 Element | Length | 13.00 | | 12.10 | 11.75 | 11.75 | 10.75 |
| | Spacing | 0.00 | 2.50 | 5.50 | 11.00 | 18.00 | 28.50 |

435 MHz AMSAT. The larger versions have not been fully tested and I appreciate the help and motivation from KA9LNV for these antennas. Updates and performance evaluations are planned for a later edition of the AMSAT Journal. A high Front-to-Back ratio was the major design consideration for all versions. The computer predicts 30 dB F/B for the 6 element and over 40 dB for the others. NEC predicts 11.2, 12.6, 13.5 and 13.8 dBi for the 6, 8, 10 and 11 element respectively. Using 3/4" square wood makes it easy to build two antennas on the same boom for cross-polarized operation. Offset the two antennas 6 1/2" and feed in phase for Circular Polarization. Or, just build one antenna for portable operation. Driven element dimensions are L = 13.0" and H = 1/2" Elements are 1/8" diameter. Spacing is the same for all versions.

| 435 MHz AMSAT | | REF | DE | D1 | D2 | D3 | D4 | D5 | D6 | D7 | D8 | D9 |
|---------------|---------|-------|------|-------|-------|-------|-------|-------|-------|-------|-------|-------|
| 6 Element | Length | 13.40 | | 12.40 | 12.00 | 12.00 | 11.00 | | | | | |
| 8 Element | Length | 13.40 | | 12.40 | 12.00 | 12.00 | 12.00 | 12.00 | 11.10 | | | |
| 10 Element | Length | 13.40 | | 12.40 | 12.00 | 12.00 | 12.00 | 12.00 | 11.75 | 11.75 | 11.10 | |
| 11 Element | Length | 13.40 | | 12.40 | 12.00 | 12.00 | 12.00 | 12.00 | 11.75 | 11.75 | 11.75 | 11.10 |
| | Spacing | 0.00 | 2.50 | 5.50 | 11.25 | 17.50 | 24.00 | 30.50 | 37.75 | 45.00 | 52.00 | 59.50 |

7-Element-Yagi for the 2m-Band with the 28-Ohm-DK7ZB-Match

This antenna was described in the issue 2/2000 of the magazine "FUNKAMATEUR" , report "Kurze Yagis für das 2m-Band in bewährter 28-Ohm-Technik".

Short data: 11dBd gain, boomlength 3,30m, very good pattern. For the match see: [DK7ZB-Match](#)

At the webpage "[DOWNLOAD](#)" you can load the report as PDF-File (german language!).



Table of Elements with 4-10mm Diameter

The radiator has always a diameter of 10mm!

| El.-Diameter | 4mm | 6mm | 8mm | 10mm |
|--------------|--------|--------|--------|--------|
| Reflector | 1019mm | 1016mm | 1014mm | 1011mm |
| Radiator | 978mm | 978mm | 978mm | 978mm |
| Director 1 | 959mm | 951mm | 945mm | 940mm |
| Director 2 | 933mm | 924mm | 916mm | 909mm |
| Director 3 | 916mm | 906mm | 898mm | 891mm |
| Director 4 | 915mm | 905mm | 897mm | 890mm |
| Director 5 | 904mm | 894mm | 885mm | 877mm |

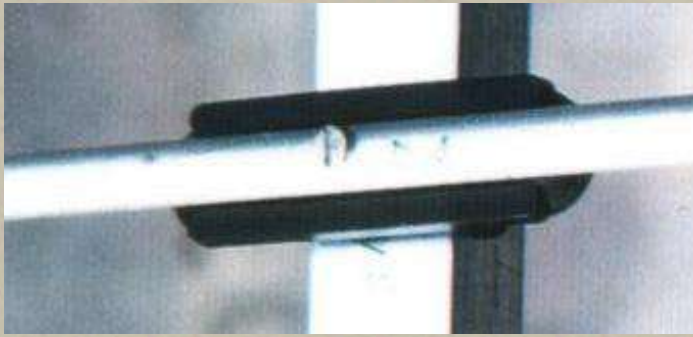

Elements are mounted **isolated** above the boom with polyamid clamps for TV-Yagis (Konni)

The screw in the center of the element has no influence to the length of the elements!

Gain, SWR,
Front/Rear and
Feedpoint-
Impedance

Best F/R in the
CW/SSB-part of
the 2m-Band

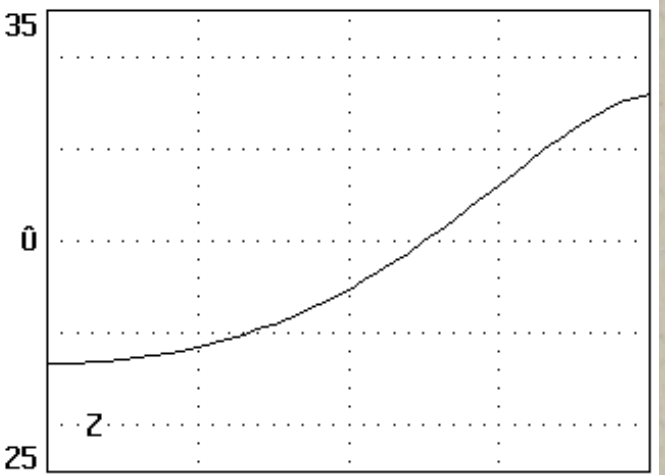
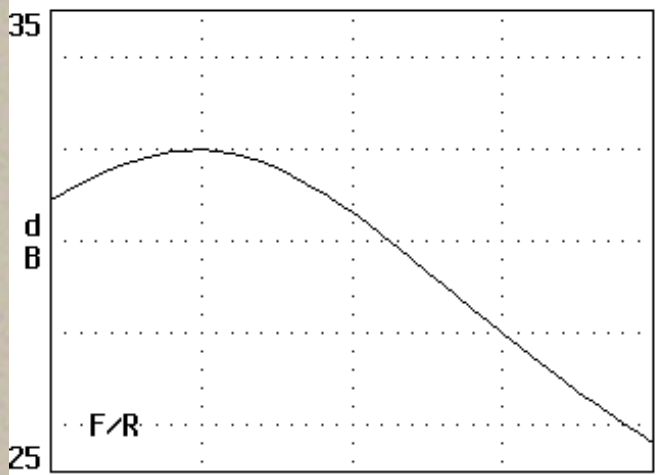
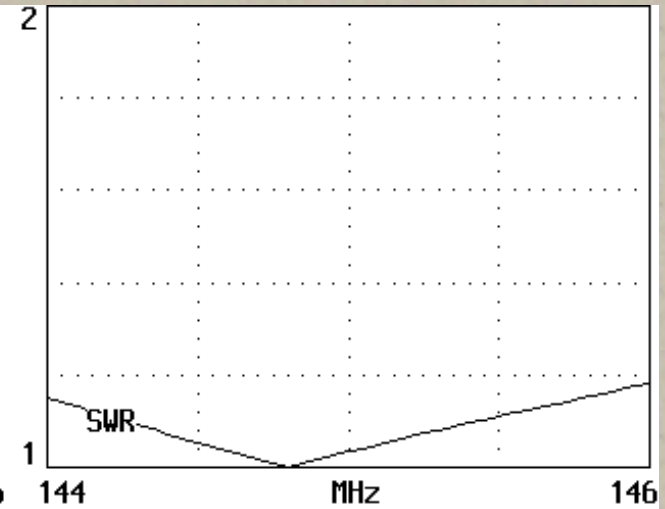
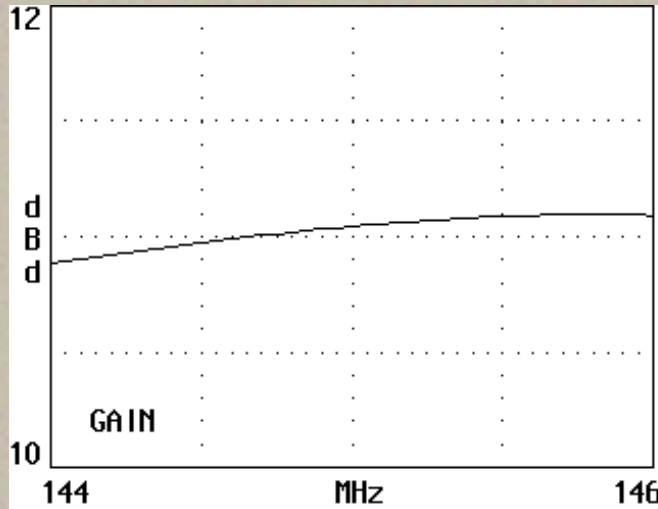

7-2-2833.YAG, 7-El.,
3.3m-Boom, 11 dBd,
28 Ohm

Free Space
E-Plane

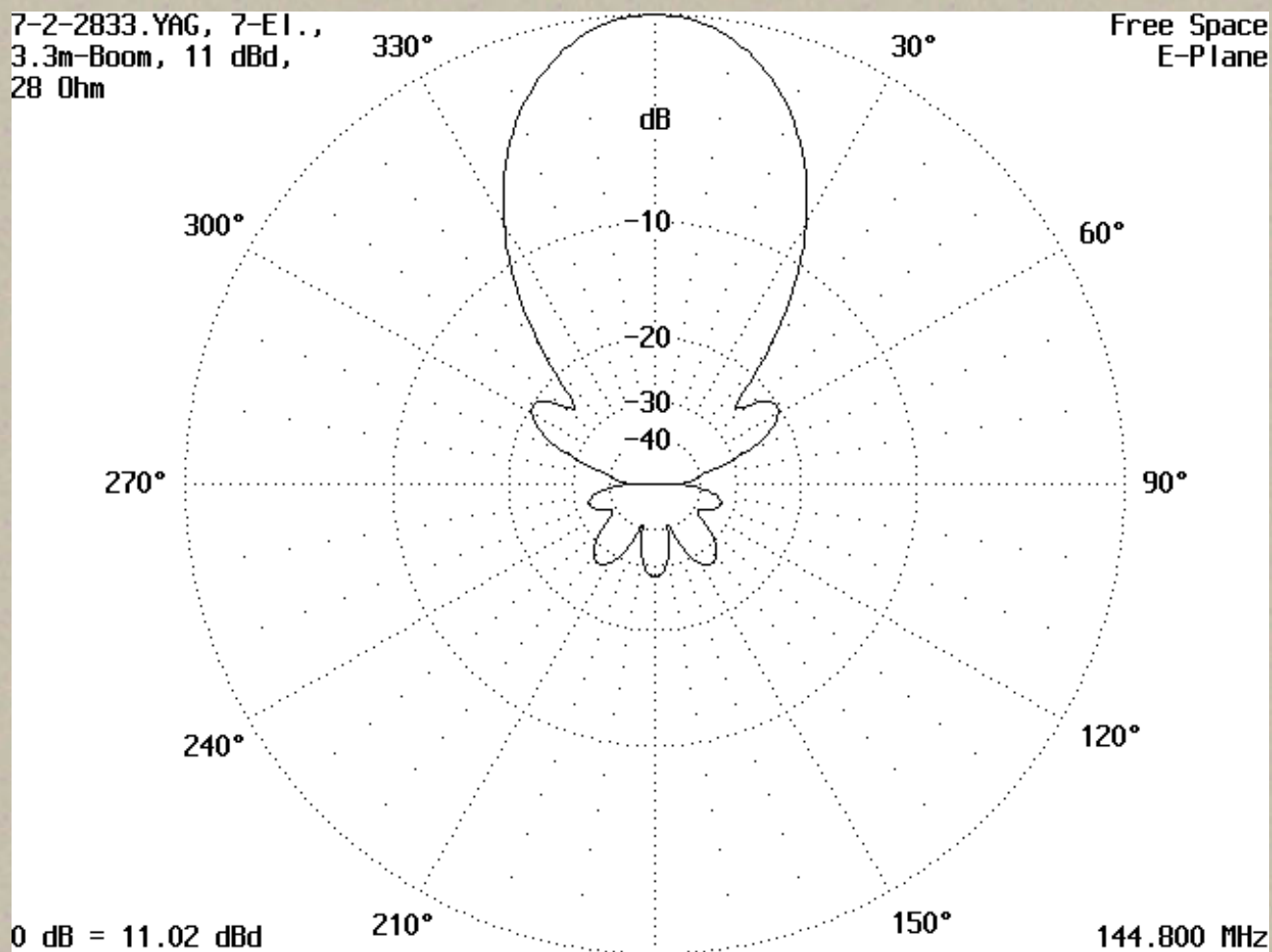

7-2-2833.YAG, 7-El.,
3.3m-Boom, 11 dBd,
28 Ohm

Free Space
H-Plane

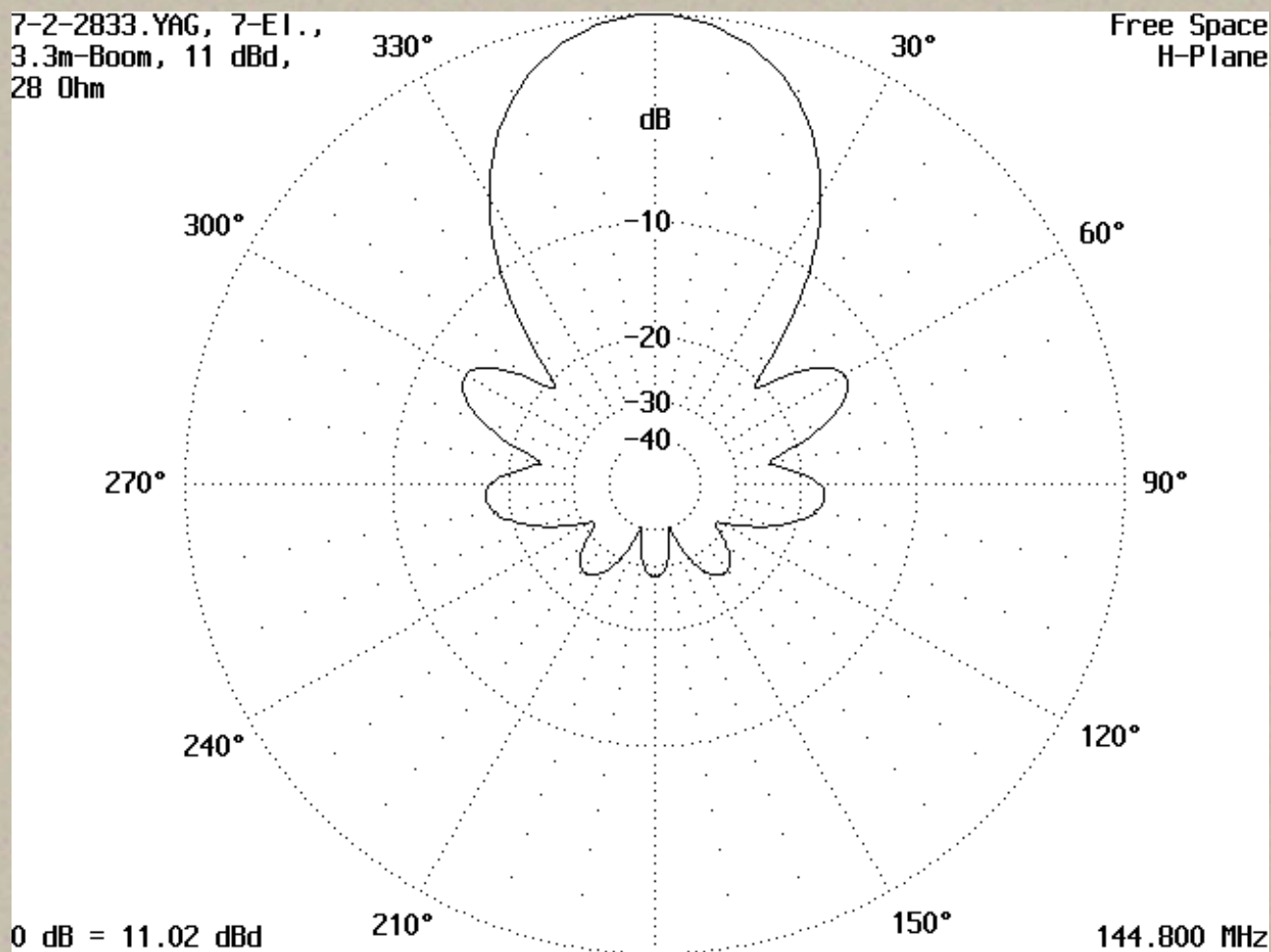

Further details and pictures can be found on the homepages of

[DC6GF](#)

[DF8GH](#)

2x7-El.-28-Ohm stacked



This page is still under construction, but I have more to report on this yagi.

This yagi is based on a design by JM1SZY for 50 MHz that he developed using YO. On 6 Metres, JM1SZY designed this antenna for good gain, fairly wide bandwidth, and a great F/B ratio.

When I scaled it to 2 Metres, it had another quality, it was just a shade over 11 feet in length! I don't know about the rest of the world, but in North America, wood and aluminum tubing is commonly sold in 12 foot lengths. So this antenna could be built with either a single length of 12 foot AL tube, or, if you can find .058" wall aluminum, out of 4 foot sections of tubing. Waste not, want not!

Here's it's free-space pattern on 144.2. It's gain is in line with the DL6WU formula for gain vs. boomlength. It's front-to-back ratio is quite good, IMHO. The far-field data came from NEC2 and was plotted using MS-Excel.

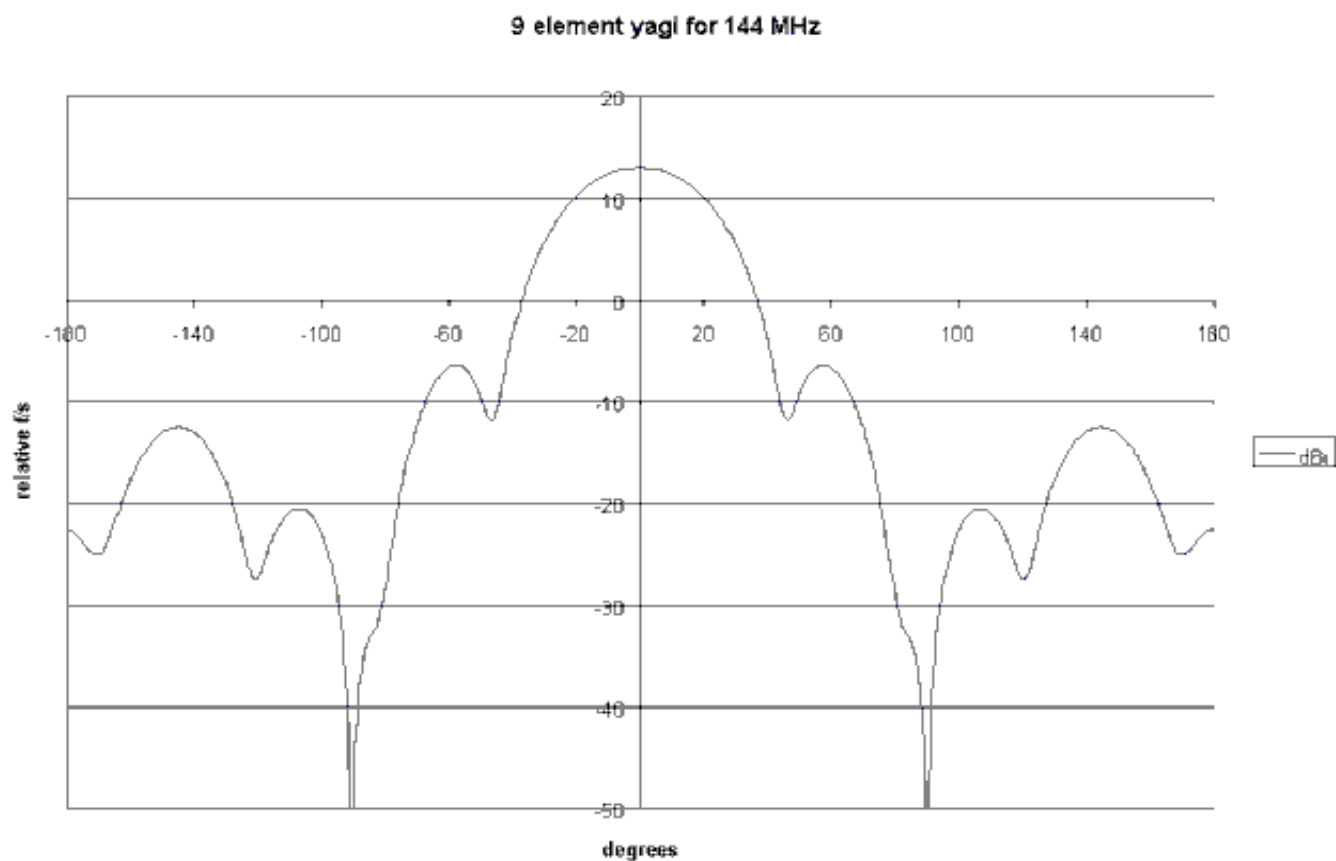

I decided have the gain peak higher up in the band from 144.2. According to K1FO, antennas designed this way are better behaved in a stacked array. I also hope to use it for OSCAR work, so having good gain near 145.9 MHz was a desirable feature, as well.

VE7BQH has done considerable work comparing yagis for 2 Metres. Again, using MS-Excel, I've taken the BQH data, and plotted a trend line showing calculated gain for various antennas. The boomlength axis is logarithmic in scale. Keep in mind, most of these big boys are used for moonbounce, so you'll find the 9 element antenna plotted at the bottom left corner: it is considerably shorter (and subsequently of considerably less gain) than the examples in BQH's table. The data used in this chart can be found at:

<http://web.wt.net/~w5un/144gt1.htm>

2 Metre Yagi Comparison (Gain)

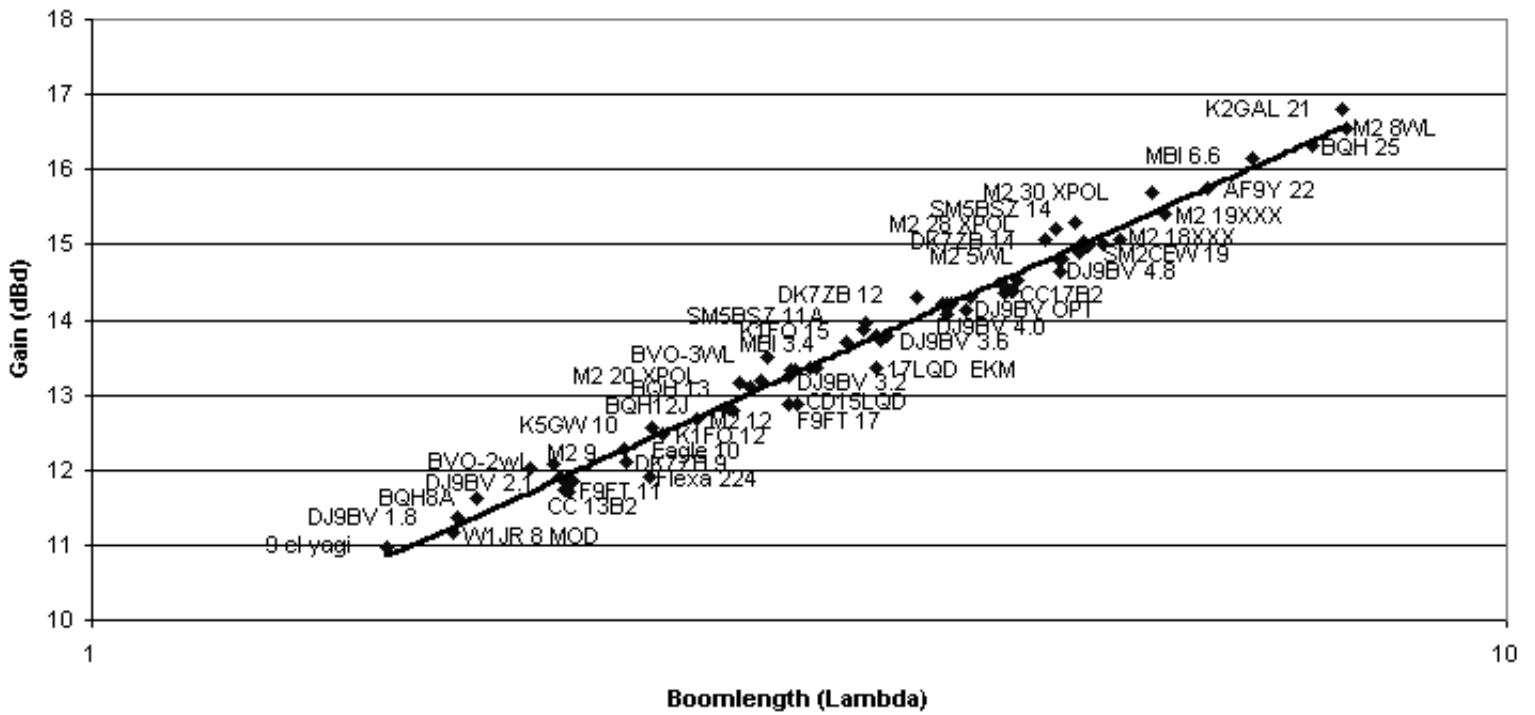

Here's a graph of gain (in dBi), F/B ratio and VSWR vs frequency that was plotted by YagiMax. I'm using a T-match with a half-wave coaxial balun, and the SWR bandwidth is similar to that shown in the graph. The gain is shown in yellow, the F/B ratio in magenta, and the VSWR in green.

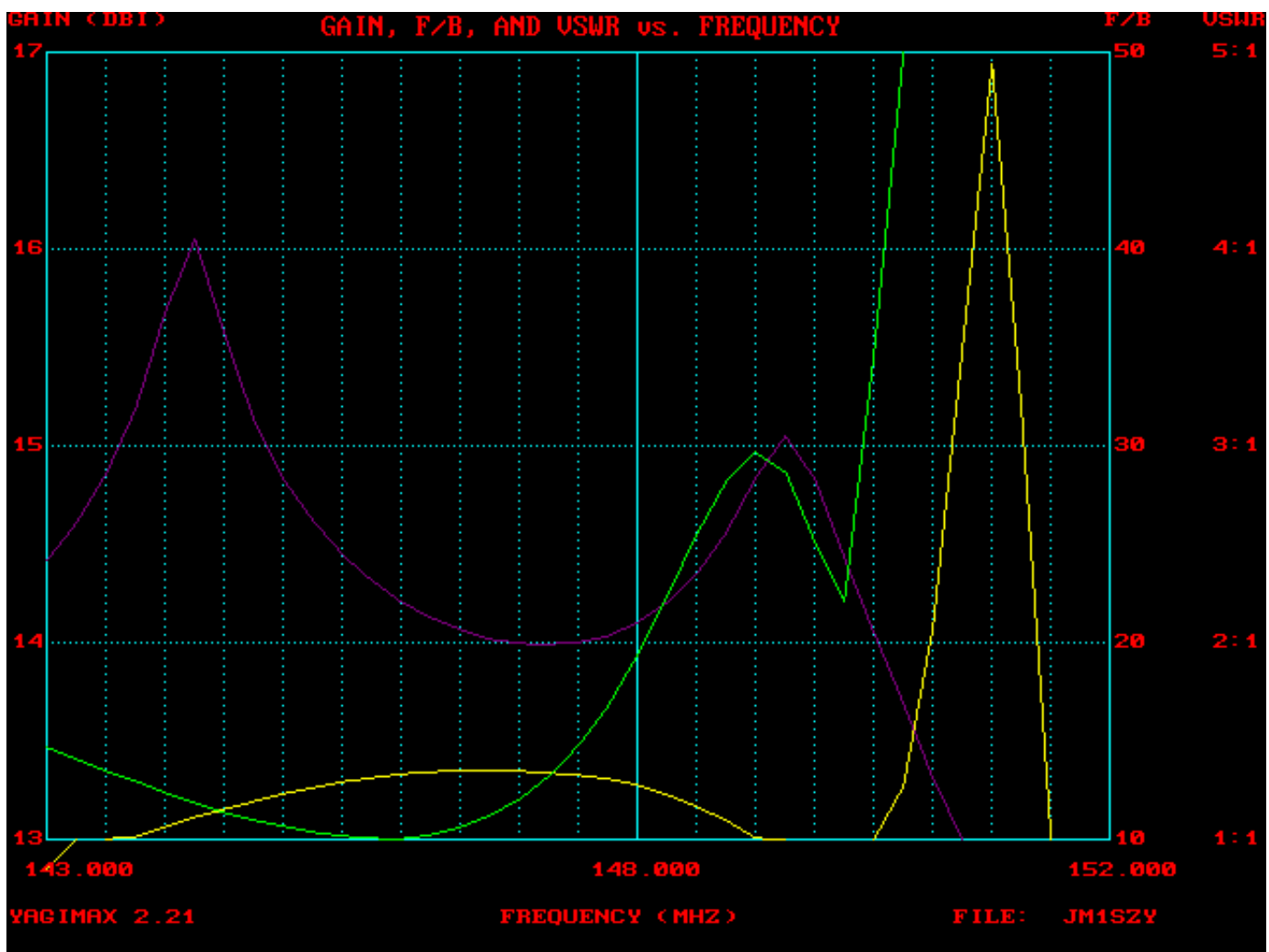

Free Space Dimensions

| Element | X axis (MM) | Y axis (MM) | Diameter (MM) |
|---------|-------------|-------------|---------------|
| REF | 0.000 | 513.584 | 4.76 |
| DE | 279.128 | 499.083 | 4.76 |
| D1 | 424.349 | 478.218 | 4.76 |
| D2 | 783.058 | 467.091 | 4.76 |
| D3 | 1301.530 | 459.510 | 4.76 |
| D4 | 1865.040 | 453.285 | 4.76 |
| D5 | 2376.020 | 442.401 | 4.76 |
| D6 | 2848.920 | 452.346 | 4.76 |
| D7 | 3365.820 | 445.000 | 4.76 |

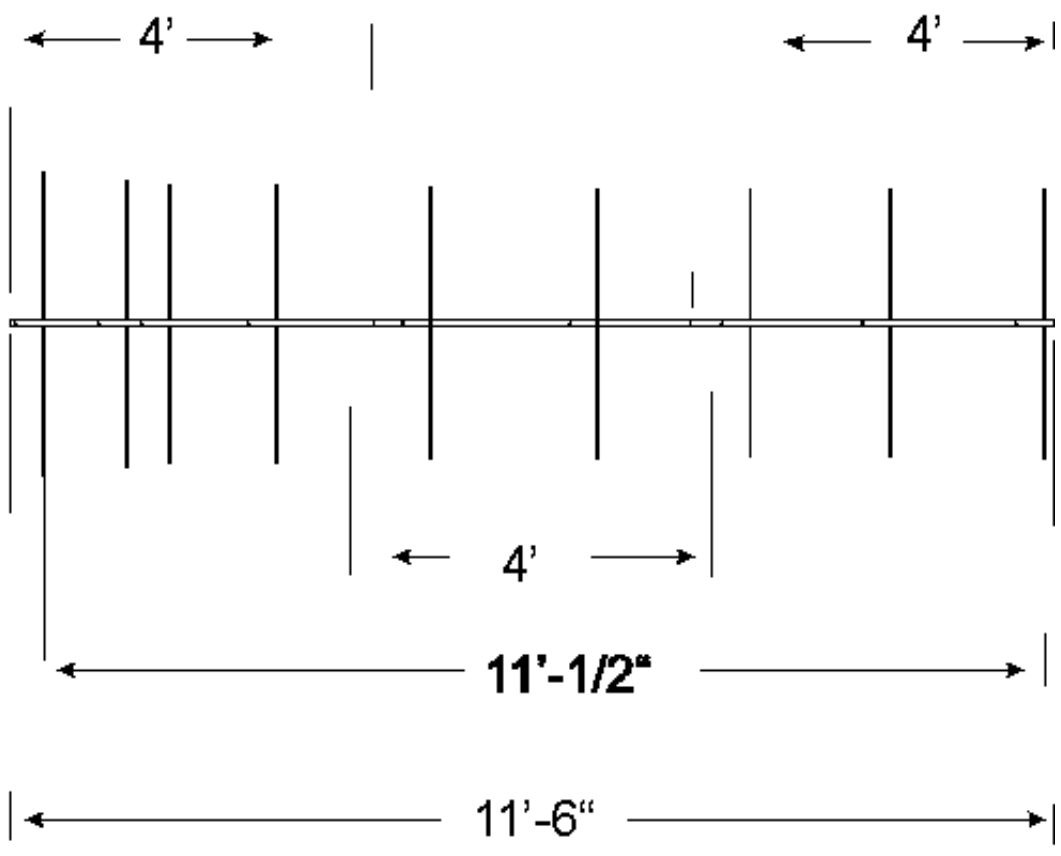



Simpleton's
Guide to:
Quickie Antennas



Brought to you by:

artsci

Artsci

Publishing

[-- Table of Contents --](#)

[-- Return to welcome page --](#)

Rebuilding a ham shack after moving into a new home is a very big job. Even if you only have a single VHF radio, running the coax and planting a new antenna system on the roof seems to take more effort each time you do it. Once you get used to drilling holes all the way through a wall for the coax, you are faced with how to support the antenna mast on the roof. If you are only renting the home, you may be tempted to strap the mast on the side of the house and limit the height to just over roof level.

After moving my family into a new home a few months ago, I set aside a weekend to work on my ham shack and antenna system. In my old house, I had an antenna for each band, 2 meters, 220 MHz and 440MHz. Since we are only renting this new home, I wanted to make use of a new multiband antenna. I drilled the holes, built the antenna and mast and bolted it to the side of the house. A triplexer (three port RF splitter) would breakout each band for connection to my three radios. I have used duplexers before, but this would be my first experience with a triplexer.

I was ready to turn the radio on and test my new system. The radios were receiving properly, but my transmitter signal was not making connections to the local repeaters. I connected the antenna to each radio and everything was fine. I connected the triplexer and hooked up a SWR meter and discovered that the SWR through the triplexer was over 5 to 1. I couldn't understand how the receive signals made it through the triplexer but my transmitter could not.

Luckily I had an old duplexer and hooked it up with great success. My 2 meter and 440 MHz radios could now operate properly. The 220 MHz radio was left without an antenna. It was now getting dark, I didn't want to drill another hole for another run of coax and there was no room on the mast for another antenna. I was not going to be defeated by that

malfunctioning triplexer.

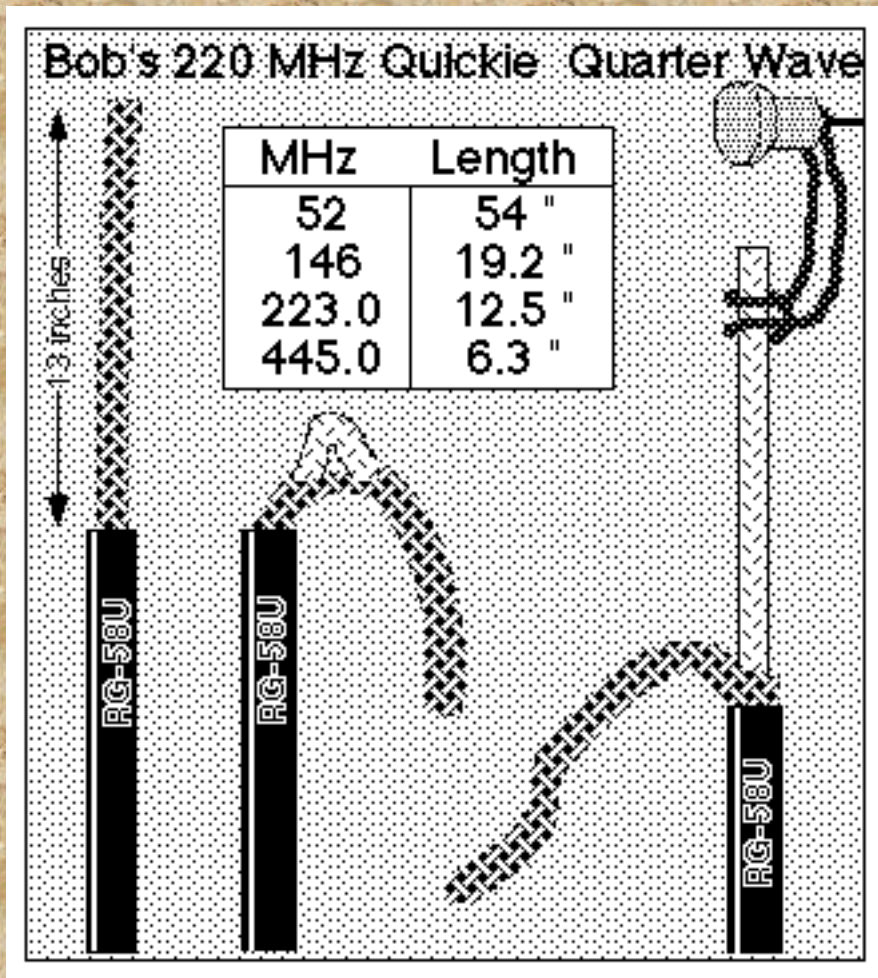

I remembered that a 220 MHz quarter wave antenna could be made using a 12 1/2" wire for a radiator and a 13" wire for the ground plane. It was then that the inspiration for a quickie antenna hit me. I had a left over 6 foot piece of coax with a PL connector on one end. I removed 13" of outer

insulation and exposed the shield. I measured down 12 1/2 inches and forced open the shield and folded the coax over and pulled out the center conductor with insulation through the hole in the shield.

I now had a 220 MHz quarterwave antenna!! I hung it from the ceiling in my shack with a rubberband and a tack. I hooked it up to the meter and measured the SWR. It was perfect.

This antenna can be built for any frequency you may need.

Just make sure the length of the radiator is correct. If you need to look up the exact length for each band, see the Simpleton's Guide to Quarterwave Antennas. You may attach the radiator to a wood board to help support it.

You must use RG-58 or similar size coax. The larger RG-8 style is much too hard to work with when you attempt to pull out the center insulation. You may be tempted to unbraid the shield instead of opening a hole and pulling out the center insulation. Try unbraiding the wire and you'll get so frustrated with the braid tangling in themselves, you'll cut off the work and start over.

Good luck and remember to have fun when you work on the hobby we call Amateur Radio.

[Top of this page](#) [Return to welcome page](#)

We would appreciate any comments you may have and we welcome your e-mail comments at :

artsci@artscipub.com

Artsci Inc.

Post Office Box 1428

Burbank, CA 91507

(818) 843-4080

(818) 846-2298 FAX

Copyright ©1996 artsci inc. all right reserved.

[Hidden Transmitter Hunting](#)
[Antennas](#)
[Cubical Quad](#)
[Yagis](#)
[J-Pole](#)
[Beam Mounting](#)
[Changing Polarity](#)
[Attenuators](#)
[Active](#)
[Switched Passive](#)
[Sniffing Equipment](#)
[Hiding Equipment](#)
[PicCon](#)
[RaCon 6805](#)
[Other Equipment](#)
[LED S-meter](#)
[Audible S-meter](#)
[T-Helper](#)
[Hunt Stories](#)
[T-Hunting Links](#)
[Byon's Page](#)

J Pole Antenna

The N6ZAV J-Pole makes a great (but not so hidden) transmitter antenna.

Using the above table, cut the tubing to the size shown for the desired band. The only section where size is not critical is the mast section. Use any size you desire for mounting purposes.

Use steel wool to clean the copper and solder the antenna together as you would with normal copper tubing. Pay close attention to keep the joints straight and snug while doing this. Soldering this together takes quite a bit of heat and a propane torch is the tool of choice.

After the antenna has had a chance to cool, you can attach the coax. Strip the end of the coax that you are going to connect to the antenna and make sure that there is just enough to span the distance between the elements. The cable should be centered between the elements. Strip the center conductor and tin it with solder if it is multi-stranded. Do the same for the braided shield. Using the stainless steel hose clamps, attach the center conductor to the "B" side of the antenna and the shield to the "A" side. Start with the connections about 3" to 5" above the bottom of the "J" and tune with an SWR meter. That's about it! See you on-the-air!

73 de Marty, N6ZAV

Parts List:

- 1 10' length of 1/2" copper tubing schedule "L" or "M"
- 1 1/2" copper tubing "T" fitting
- 1 1/2" copper tubing elbow fitting
- 2 1/2" copper end caps
- 2 small stainless steel hose clamps
- 1 50 ohm coax cable with connector for radio.

Element Size Table:

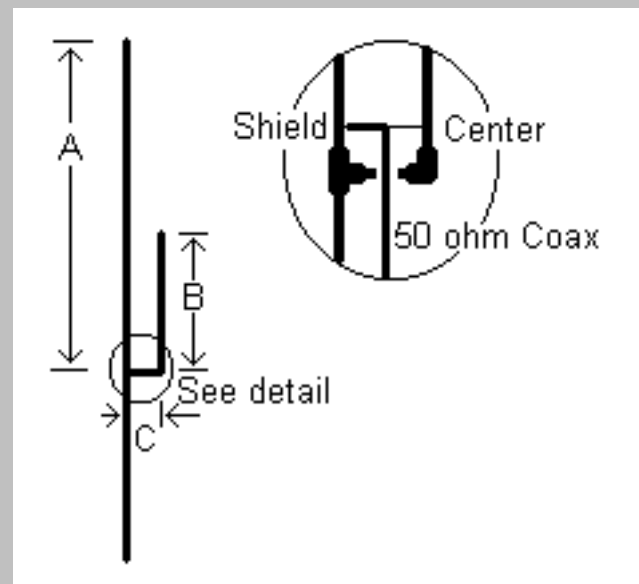

2 Meters

220 MHz

| | Total length | Cut | Tubing | Total length | Cut | Tubing |
|--|--------------|-----|--------|--------------|-----|--------|
|--|--------------|-----|--------|--------------|-----|--------|

| | | | | | | |
|---|---------|----|------|---------|----|------|
| A | 60 5/8" | 60 | 1/4" | 39 3/4" | 39 | 3/8" |
|---|---------|----|------|---------|----|------|

| | | | | | | |
|---|---------|----|------|---------|----|------|
| B | 20 1/4" | 19 | 7/8" | 13 1/4" | 12 | 7/8" |
|---|---------|----|------|---------|----|------|

| | | | | | | |
|---|----|---|------|----|---|------|
| C | 3" | 2 | 1/4" | 2" | 1 | 1/4" |
|---|----|---|------|----|---|------|

This page by [Byon Garrabrant](#) N6BG byon@mail.com 12/24/97

How to build a high gain vertical antenna for the UHF amateur or CB bands

You can use low-cost coaxial cable to make a simple, high performance, omnidirectional vertical antenna that is ideal for both home station and portable applications.

THE collinear antenna has been around a long time. Various versions enjoyed popularity on the amateur VHF and UHF bands in the eras before and after World War II. But the collinear fell out of favour when the Yagi array became popular since the late '50s. The Yagi's popularity is attributable to its feature of giving the 'best bang for the buck'. But it is a beam which requires rotating.

With the rise in popularity of FM operation on the VHF and UHF bands since the '70s, the proliferation of commercial amateur rigs, and the development of repeater networks around the country, the demand for omnidirectional antennas grew apace. A lot of FM activity is mobile, with a degree of base or home station operation, too. For the latter application, an omnidirectional antenna with gain offers distinct advantages, particularly where comparatively low-powered mobile rigs are used at home.

The growth of UHF CB has followed a similar path, boosted by the availability of locally-manufactured transceivers selling alongside imports. Open access repeaters helped the growth of UHF CB, too.

A home-constructed antenna can save you big bucks. Many constructors make up a simple groundplane or coaxial dipole, which have the advantage of simplicity. However,

something that offers a respectable amount of gain and can be assembled with little more effort is a bonus.

The collinear antenna to be described offers considerable gain and improved bandwidth over the conventional groundplane, coaxial dipole, 'Slim Jims' or similar antennas. It is simple to construct and erect since it does not require tuning or pruning, and uses cheap, commonly available 'quarter-inch' RG-58 coax.

The word *collinear* means 'in line', the elements of the collinear antenna being placed in line, end to end. Two half wave dipoles placed end to end and fed out of phase make the simplest two-element collinear.

A collinear from coax

To make a collinear antenna from coaxial cable, a number of elements, each an *electrical* half wavelength long, are joined together with the inner conductor and the shield braid transposed at each joint, as illustrated in Figure 1. An even number of elements is required. By transposing the coax's inner and outer conductors at each joint, each half wave element is fed out of phase.

I first ran across this form of the collinear in a scientific publication in the early '70s. The published paper described a monstrous, 400 metre long, 104 element array used for a

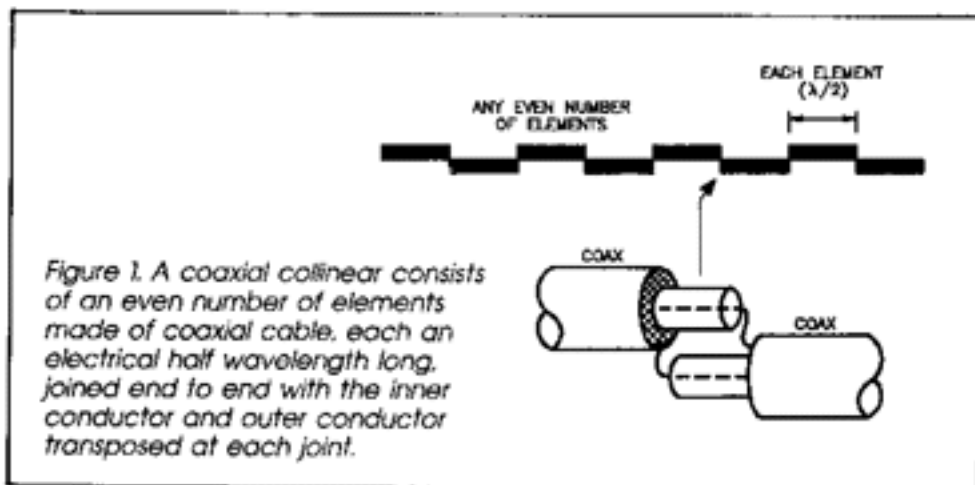

advantage of simplicity. However,

Page two

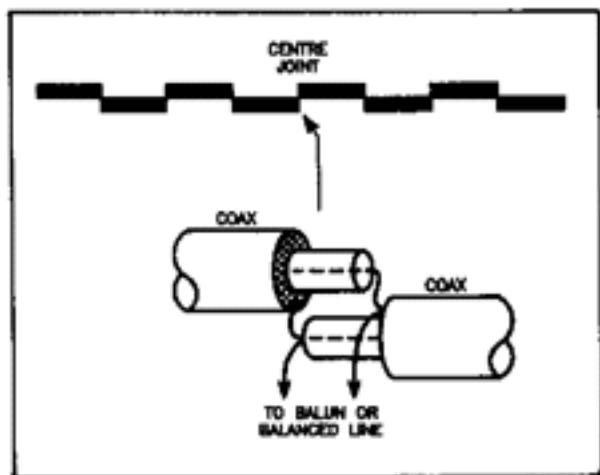

Figure 2. Coaxial collinears may be fed at the centre, as illustrated here, or at the end, which is used in the antenna described (see Figure 3).

50MHz radar located at Jicamarca in Peru, used for probing the ionosphere. The beamwidth of this wonder was reported to be just one degree!

The number of elements used determines the gain, beamwidth and bandwidth of a coaxial collinear antenna. The gain increases by 3dB every time you double the number of elements. Two elements provides a gain of 3dB compared to a dipole, four elements would give 6dB, eight elements 9dB, etc.

For the technically inclined, the bandwidth is generally defined as the point at which the gain degrades due to phase variations greater than one-sixth pi radians on the end elements. You can calculate the bandwidth from:

$$\text{bandwidth} = 2f / (3n + 1)$$

where 'f' is the centre frequency of operation, and 'n' is the number of elements in the array.

The interesting thing is, if you use lossy coax, the antenna's performance improves without markedly decreasing the gain or increasing the beamwidth. Hence the use of common-or-garden RG58!

Feeding it

You have two opportunities to connect a feedpoint to the coaxial collinear – in the middle, or in the end. When centre fed, the feedline is connected across the centre joint, as illustrated in Figure 2.

As you may already appreciate, this is a balanced connection and requires a balanced line or a balun transformer to connect unbalanced coaxial feedline. The feedpoint impedance is a few hundred ohms, allowing the use of

solution, and you get a direct match to 50 ohm coax!

However, you can't just connect the coax to the end of the array, the radiation from the elements will couple onto the outer conductor (shield braid) of the coax and you get a 'hot' line. There are various ways to overcome this, but one of the simplest to implement is the addition of two groundplane elements at right angles, a quarter wavelength below the feedpoint. These groundplane elements, just like those on a conventional quarterwave ground-plane, are a few per cent longer than a half wavelength tip-to-tip. You can use more than two if you wish.

Making it

This is one of my favourite do-it-yourself antennas as it's easily made, is not critical on dimensions, needs no tuning adjustments, matches directly to 50 ohm coax and goes together in quick-smart time. You can buy all the bits and make it in less than a day and have it on the air the same evening.

The general arrangement and dimensions of an 8-element coaxial collinear array are shown in Figure 3. The dimensions shown put the antenna's centre frequency on 436.5MHz for the 70cm amateur band; the dimensions in brackets put the antenna's centre frequency on 476.9MHz, the middle of the UHF CB band. This makes the array of a size which is readily handled – about two metres tall for the 70cm version, and about 1.8 metres tall for the UHF CB version.

There are two band segments 'reserved' on the 70cm amateur band

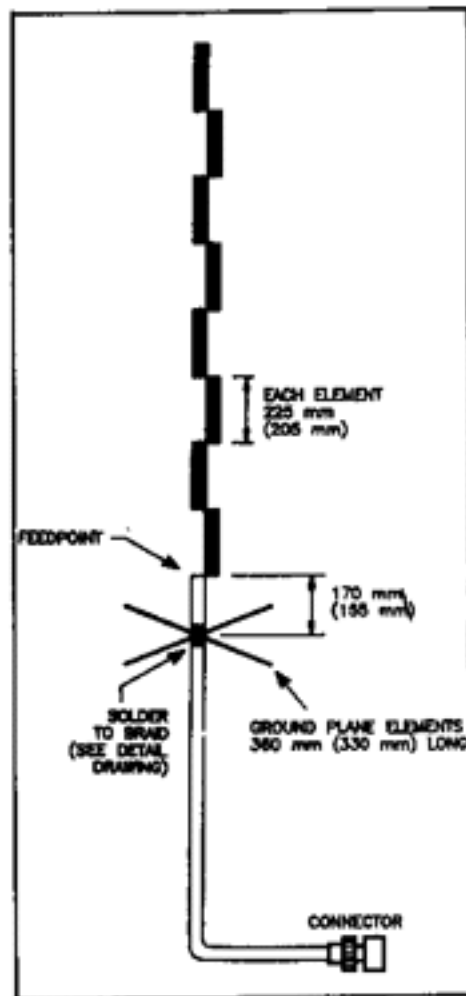

Figure 3. The general form of the UHF coaxial collinear antenna described. Dimensions are shown for the 70cm amateur band and the UHF CB band (in brackets).

the velocity factor of the coax must be taken into account. As electromagnetic energy travels slower in the dielectric of the coaxial cable, a wavelength is physically shorter. The velocity factor of common RG58 is approximately 0.65-0.66.

It is fortunate that the bandwidth of the collinear is quite broad – about 35MHz, or around 8 per cent – as this allows plenty of tolerance in the dimensions. Around plus/minus 5mm, actually.

Buy three metres of RG58CU coax and get good quality cable, such as one with a 'MIL-C-17F' specification (it's often referred to as 'RG58CU Commercial'). Retailers such as Dick Smith Electronics, Captain Communications and Emtronics carry suitable RG58. In addition, you will need

to connect unbalanced coaxial feedline. The feedpoint impedance is a few hundred ohms, allowing the use of a simple 4:1 balun.

But feeding a collinear in the middle is awkward when you want to mount it vertically. The feedline must come away from the array at right angles. So, feeding it from the bottom is the

UHF CB version.

There are two band segments 'reserved' on the 70cm amateur band for FM simplex and repeater operation, these being 433.025-434.975MHz and 438.025-439.975MHz. Thus, 436.5MHz is in the middle.

As I said earlier, each element is an electrical half wavelength long. That is,

SMITH ELECTRONICS, Captain Communications and Emtronics carry suitable RG58. In addition, you will need 500mm of 9.5mm or 12.7mm diameter heatshrink tubing and about 50mm of 6.4mm heatshrink.

As you would appreciate, the collinear is not self-supporting; it's distinctly floppy. To hold it up, attach it

Page three

to any non-conducting support. Dowelling rod from your local hardware store is great for this job and it comes in standard two metre lengths, which is just right. Choose 12.7mm or 19mm diameter dowel, to suit yourself.

Now, go through the following procedure step by step and you'll find your collinear goes together quite easily.

1) The very first thing to do is prepare the collinear's support, using a 12.7mm or 19mm diameter wooden dowel rod. This is cheap, readily available and strong enough for the job. The dowel should be thoroughly sealed with an outdoor wood stain or linseed oil, paying particular attention to the ends. Stand it aside to dry properly.

2) Now for the collinear itself. The 'working' length of each element is the distance between the ends of the braid. To simplify matters, and to allow for the odd error, cut eight lengths of RG58, each 250mm long for the 70cm amateur band, or 230mm long for the UHF CB band. These lengths make allowance for cutting and stripping back the ends of the elements to make the joints.

3) Prepare each end of seven elements, and only one end of the eighth element, as detailed in Figure 4. The eighth element will become the 'top' element of the antenna.

Cut the coax's outer sheath 16mm back from the end using a blunt penknife or hobby knife. It should be blunt so as to avoid nicking the shield braid here. Do not unravel the shield braid.

4) Now cut the braid, this time using a sharp knife, 8mm back from the end. Take care not to cut through the dielectric to the centre conductor. Combined use of a sharp knife and sharp, pointed sidecutters can be effective and result in a neat cut.

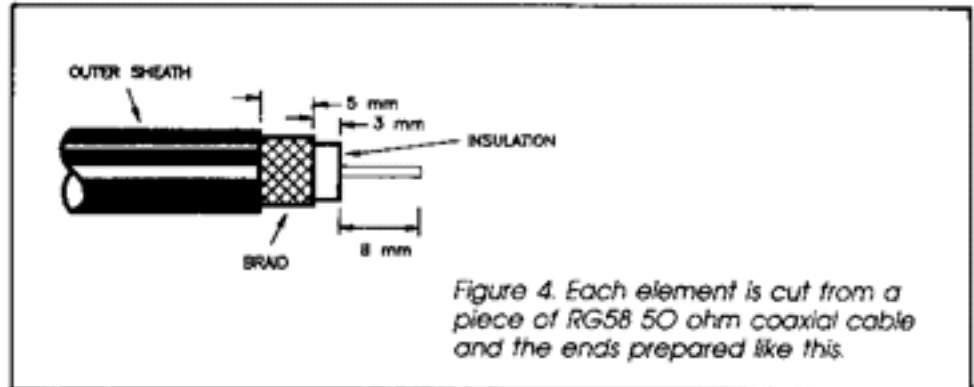

Figure 4. Each element is cut from a piece of RG58 50 ohm coaxial cable and the ends prepared like this.

for a few seconds to heat it, then apply the solder. Use thin gauge, resin-cored solder. But remember to only apply enough solder to lightly 'wet' the conductors.

7) Now to solder the elements together. First slip a 35-40mm length of 9.5mm or 12.7mm diameter heatshrink on each element. Solder the elements together, end to end, as shown in Figure 5. With each joint, after it has cooled, apply silicone sealant to the area of the joint to seal it, then, while the silicone is still plastic, slip the heatshrink tubing over the joint and apply a blast of hot air (hair dryers are great for this). But don't overdo the hot air, though, or you're likely to soften the outer sheath of the coax and possibly damage it.

8) The top element needs to be sealed. Apply a dab of silicone sealant to it, slip on a 30-40mm length of 6.4mm heatshrink while it's still soft, then apply a short blast of hot air to shrink it in place.

9) The next step is to attach what you've just completed to its support. Plastic zip-up cable ties are great for this, as are the plastic zip-lock ties that come with packets of garbage bags. Tie the collinear to the dowel, starting with the top element, putting a tie either side of each joint. The top element should be tied about 50mm below the top end. The other elements should be near the joints.

While the collinear should be laid straight when tying it to the dowel, don't

mechanical support, its prime purpose is protection.

10) Now for the feedpoint and groundplane. You'll have a short length of RG58 left over. Attach a suitable in-line connector, such as a BNC male, to one end and prepare the other end as per Figure 4.

Measure back along the cable, from the end of the shield braid, a quarter wavelength (this time, 'free space' wavelength). For the 70cm amateur band, this is 170mm; for the UHF CB band, 155mm. Mark this point.

Using a blunt knife, or carefully using a sharp knife, make two cuts around the cable's outer sheath, each a few millimetres either side of this point. Slit the sheath between the two cuts and remove the section to expose the shield braid. Using a hot iron, quickly and lightly tin the braid. Slip two 30-40mm lengths of 6.4mm diameter heatshrink down the cable, placing them either side of the exposed shield braid.

11) Cut two lengths of tinned copper wire or brazing rod to size: each 360mm long for the 70cm amateur band, and 330mm long for the UHF CB band (see Figure 3). If you're using tinned copper wire, straighten it first. This can be done by clamping one end in a vise, grasping the other end with a pair of pliers and giving it a good tug. It will bow a bit after you take it out of the vise, but then you can straighten it easily by hand. Tin the centre of each groundplane element.

12) Now attach the prepared cable to

Combined use of a sharp knife and sharp, pointed sidecutters can be effective and result in a neat cut.

5) Next, cut back the dielectric 8mm back from the end to expose the centre conductor. Do this carefully so you don't nick the stranded centre conductor wires. Otherwise, later you may get a break in the centre conductor, or a stray strand may short the joint. Either way, your antenna won't work properly.

6) With the ends of all the elements prepared as per Figure 4, now tin the exposed centre conductor and shield braid on each. Use a hot iron, preferably a temperature controlled type. A flat-faced ('spade') tip is best for this job. Apply the tip to the part to be tinned

near the joints.

While the collinear should be laid straight when tying it to the dowel, don't apply too much tension to avoid fracturing the soldering at the joints. Don't depend on the heatshrink for

can straighten it easily by hand. Tin the centre of each groundplane element.

12) Now attach the prepared cable to the feedpoint, making a joint as per Figure 5. Seal it and cover it with heatshrink. Put a tie either side of the

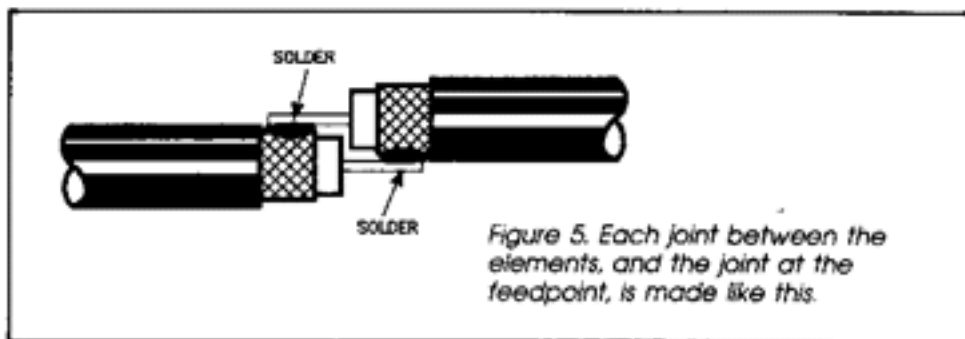

Figure 5. Each joint between the elements, and the joint at the feedpoint, is made like this.

24 RADIO EXPERIMENTER'S HANDBOOK

Page four

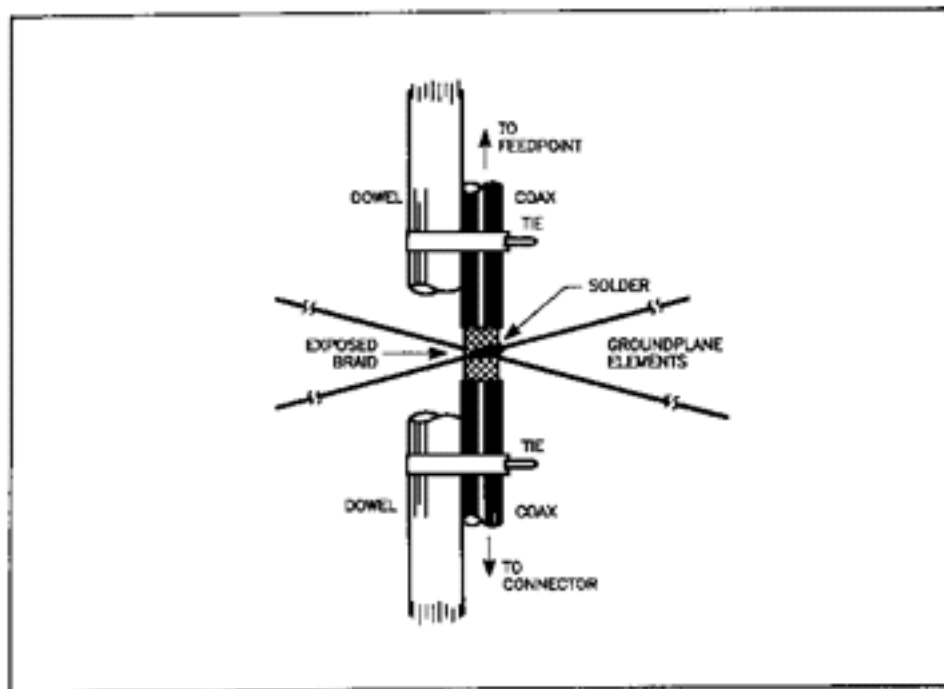

Figure 6. You make the groundplane in this manner. Be sure to thoroughly seal the area of the exposed braid, as described in the text.

joint to hold it securely to the dowel.

Now, temporarily tie the coax to the dowel near the exposed shield braid. This will secure it while you attach the groundplane elements. Position each groundplane element on the exposed braid and solder them in place at right angles to each other. Take care to solder them properly but not to damage the coax, either (a hot iron with a spade tip is best for this).

13) When the joint is cool, take off the

temporary ties and apply a little silicone sealant around the groundplane joint. While the silicone is still plastic, slip the two pieces of heatshrink tubing along to cover the groundplane joint and apply a blast of hot air. Afterwards, cover the joint thoroughly with silicone sealant (you don't want water getting into the coax).

14) Put ties around the dowel and coax, either side of the groundplane, then another tie a little below the groundplane to secure the flying lead, leaving a slack 'kink' in the cable so that any tension is taken by the bottom

though, it's better to pay more and get a cable with the lowest-loss. Belden 9913 is the best of the flexible half-inch cables around and it's stocked by Dick Smith Electronics. You're next best choice would be 'RG213 foam', which is also available from Dick Smith Electronics.

You must mount the collinear well clear of other vertical structures, particularly if they're metallic. The antenna described is readily mounted on a standard TV chimney mount, or even a barge-board mount.

Performance

An eight element array like this has 9dB of gain over a dipole. Your 10 watt rig will sound like an 80 watt rig on a Slim Jim, or like a 100 watt rig on a groundplane - it's cheap gain! A transistor power amp to take your rig's output from 10W up to 80- or 100 watts will cost you \$2 per watt, or more. So this collinear costs about one-tenth the price of a power amp. So, how much power will it take? As much as you're legally allowed to run 'up the stick.'

If you live in a valley and hope this antenna will 'get you out', expect the unexpected. It may make things worse because of its low radiation angle. The gain is achieved by compressing the vertical radiation angle. Try it. If you don't get the improvement expected, chop off the top four elements and try

PARTS LIST

Two metres of RG58CU (MIL-C-17F preferred)
 500 mm of 9.5 or 12.7 mm diameter heatshrink
 100 mm of 6.4 mm heatshrink in-line coax connector to suit (BNC suggested)
 800 mm of 18 gauge tinned copper wire or brazing rod
 Two metre length of 12.7 mm or 19 mm diameter dowel
 Five or six cable ties
 Silicone sealant
 Solder
 Outdoor wood stain or linseed oil

TOOLS YOU'LL NEED

Sharp penknife or 'hobby' knife
 Sharp, pointed sidecutters
 Soldering iron, preferably temperature controlled
 Small shifting spanner
 Pair of needle-nose pliers

groundplane to secure the flying lead, leaving a slack 'kink' in the cable so that any tension is taken by the bottom-most tie.

15) Last of all, put some sort of cap over the top end of the dowel and seal it to prevent it weathering. A damp dowel degrades the collinear's performance, so use a rubber furniture bung of the right size. Or, a short length of heatshrink tubing of the right diameter, tied off and shrunk in place.

That completes the construction. Now to erect it. As individual circumstances vary widely, I'll just give a few hints and tips.

The bottom end of the dowel can be clamped to the top of a mast using hose or muffler clamps that are tightened with a worm-drive mechanism. Use two clamps spaced apart a little to properly support the dowel.

The feedline from your collinear to your rig should be a good quality, low-loss coax. The large diameter 'half-inch' variety is readily available, and affordable. For these frequencies,

vertical radiation angle. Try it. If you don't get the improvement expected, chop off the top four elements and try again. It sounds weird, but I know of one constructor who successfully performed this operation, to his surprise, but not mine!

I have made various versions of coaxial collinears over the years, for both temporary, permanent and portable applications. A portable collinear is easily made by tying or taping the coax elements and lead cable to a length of hemp rope. In use, the top end of the rope is tied off to something suitable, like a tree branch or other form of 'skyhook', and the bottom end is either tied down or weighted so that the array is held vertical. When not in use, just roll it up.

I've made four-element coax collinears for 2m, in both 'fixed' and portable versions, an eight-element centre-fed horizontal monster some 15 metres long for six metres, and UHF versions ranging from a four-element job for mobile use to a 16 element phallic symbol nearly four metres tall. ●

Build A 9 dB, 70cm, Collinear Antenna From Coax

By N1HFX

Recently the RASON technical committee was hard at work at the repeater site repairing our 2 meter repeater antenna. One of the members commented to me that I should write an article about collinear arrays so that we could all build our own. While it is not always feasible to home-brew a commercial quality antenna designed to take hurricane force winds, it is very feasible to built a collinear antenna for average use. This article describes a collinear antenna made from very inexpensive RG58/U coaxial cable and encased in PVC pipe.

Before we start building we need to cover some ground about the characteristics of coaxial cable. First remember that there is something called the velocity factor for coaxial cable. For RG58/U coax it is typically .66. This means that when we calculate the length of $\frac{1}{2}$ wavelength in free space we need to adjust its size by multiplying it by the velocity factory. Simply put, RF slows down by the velocity factor when traveling through coaxial cable. All that aside now, lets calculate the $\frac{1}{2}$ wavelength of RG58/U coaxial cable with a frequency of 444 Megahertz:

$$\frac{1}{2} \text{ wavelength of coax} = 300 / F / 2 * V$$

Where F = Frequency in Megahertz

V = Velocity factory of Coax

$$300 / 444 / 2 * .66 = .2229 \text{ meters or } 223 \text{ millimeters}$$

To allow for cutting the ends of our coax, we will need to add 8 millimeters to each $\frac{1}{2}$ wave length for a total of 231 millimeters.

To get started, we will need 8 half wave lengths (231 millimeters) of RG58/U coaxial cable to be cut and connected in the manner shown in Figure 1. First cut back 4 millimeters of the outer jacket, braid and dielectric exposing the center conductor as in Figure 2. Now cut back the outer jacket another 4 millimeters to expose the braid and push the braid back about a millimeter to prevent it from shorting with the center conductor. It is best to lightly tin the braid with solder at this point. Now solder each half wavelength as shown in Figure 1. Attach a few feet of RG58/U to the bottom of the array as in Figure 1 for feeding the antenna.

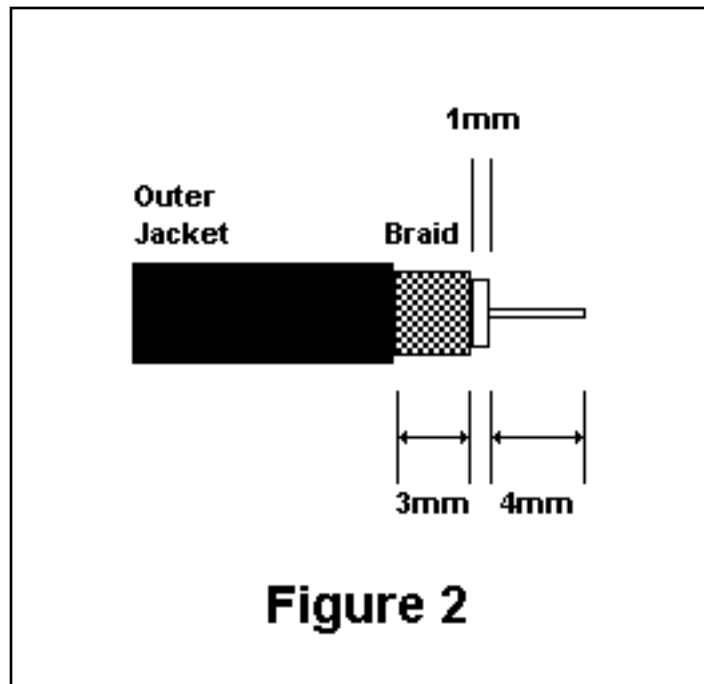
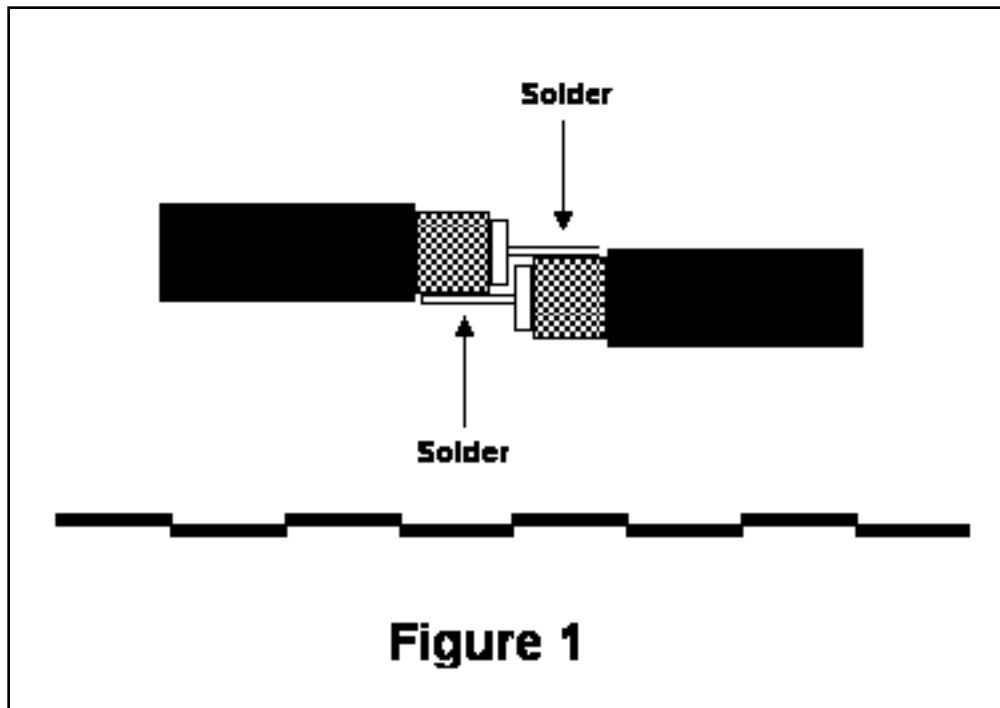

Now its time to add the additional elements to the top and bottom of the collinear array. First add a ¼ wave element to the top of the antenna as shown in Figure 3. Use #16 solid wire or similar and solder it to the center conductor only. The length of the ¼ wave element is calculated as follows:

$$1/4 \text{ wavelength radiator} = 300 / F / 4$$

Where F = Frequency in Megahertz

$$300 / 444 / 4 = .1689 \text{ meters or } 169 \text{ millimeters}$$

At the bottom of the array we will slide a 5/16 inch aluminum tube over the coax and crimp it to the braid of the antenna feed point only. If copper is used, it is okay to solder. The length of the tube is calculated as follows:

$$\frac{1}{4} \text{ wavelength of tubing} = 300 / F / 4 * V$$

Where F = Frequency in Megahertz

V = Velocity factory of Tubing. (Use .95 for 5/16" tubing)

$$300 / 444 / 4 * .95 = .1604 \text{ meters or 160 millimeters}$$

Because a collinear antenna is hot with RF along the shield of the coax, it is necessary to prevent the RF from coming back through the coax. Slide three FT50-43 or almost any similar sized toroids over the bottom end of the coax as shown in Figure 3. The toroids should be placed about $\frac{1}{2}$ wave length from the bottom of the array. Use the same formula for calculating a half wave length of coax. If you prefer, apply RF to the antenna at this point and slide the toroids up and down until minimum SWR is found. Tape the toroids to the proper point on the coax using electrical tape or similar means.

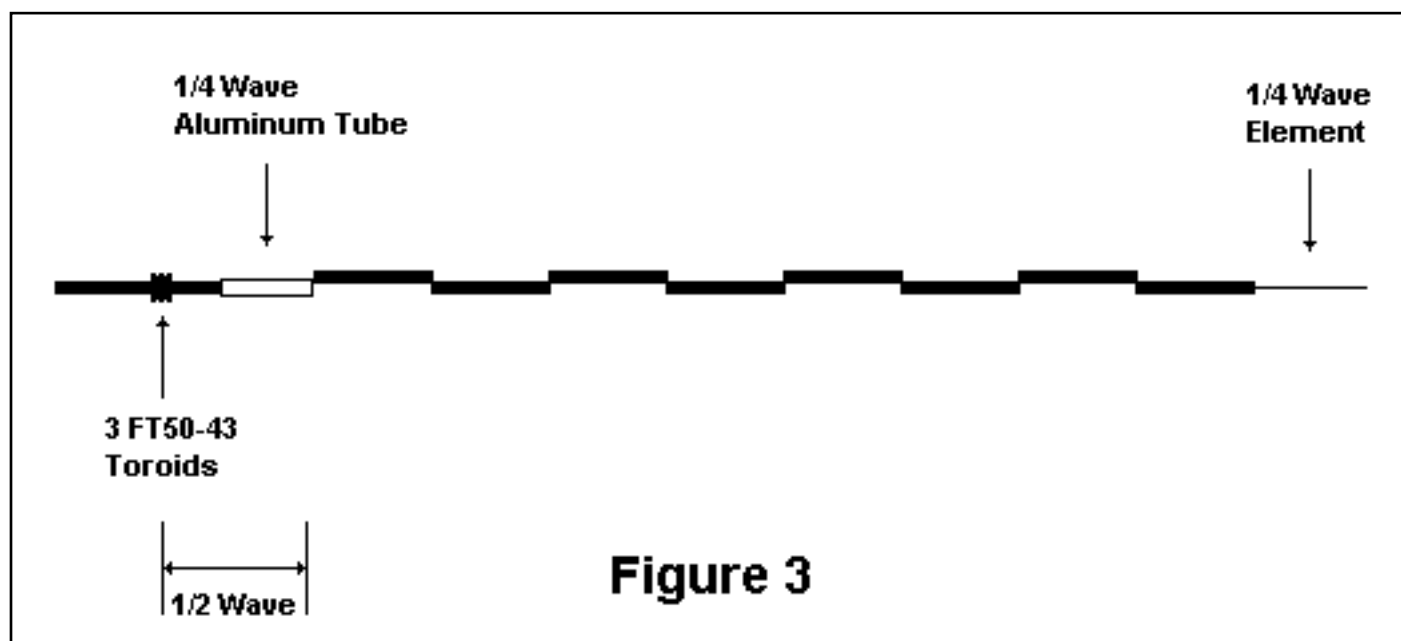

After completing the basic assembly of the collinear antenna, apply a small amount of RF with the antenna on the floor or ground. Relatively low SWR should be observed at this point. The SWR will be much lower once the antenna is mounted in the air. If the SWR is greater than 2 to 1 across the entire band, a connection may be separated or a short occurred. It will be necessary to correct the problem before proceeding. After good SWR is obtained, place heat shrink tubing along all connections or wrap tightly with electrical tape.

For final mounting, attach the antenna to a $\frac{1}{4}$ " wooden dowel using tie wraps about every 3 inches. It may not be possible to obtain a wooden dowel for the complete length so attach two dowels together by using a 1 inch sleeve of 5/16" tubing and crimping the tubing at each end. Check SWR again to insure that no connections have separated or shorted. Carefully insert the coax and dowel assembly into several feet of $\frac{3}{4}$ " PVC pipe for final mounting. Because of the tie wraps, it is not necessary to use spacers but may be necessary if larger size piping is used. Drill a hole for the coax at the bottom end cap and place an end cap on the top of the PVC. Do

not cement end caps until the SWR has been doubled checked. Cement end caps and water proof coax opening on the bottom. Use whatever type of coaxial connector is desired on the bottom of the coax end but do not use RG58/U for your complete feed line. Use a low loss coax such as RG8/U for the main feed line to the transceiver. Don't forget to water proof all coax connectors.

If the eight $\frac{1}{2}$ wave coaxial elements result in an antenna too long for your liking (over seven feet), then it is okay to use four $\frac{1}{2}$ wave coaxial elements but the SWR may be slightly higher (Attach four $\frac{1}{4}$ wave vertical ground radials at the antenna feed point to help lower SWR.). If 9 dB gain is still not enough for you then increase the number of coax elements from eight to sixteen. You will probably need to attach guy lines to the antenna. Although only a 70 CM antenna was described in this article, the formulas can be easily calculated for the 6 meter, 2 meter or $1\frac{1}{4}$ meter bands. Millimeters were used for many of the measurements but can be converted to inches by dividing millimeters by 25.4 for those who are not familiar with the metric system. After installing one of these antennas, be prepared to hear stations and repeaters that you never heard before.

DE N1HFX

[Back to Projects Page!](#)

432 8 Element Quagi Antenna

8 Element 432 Mhz Beam

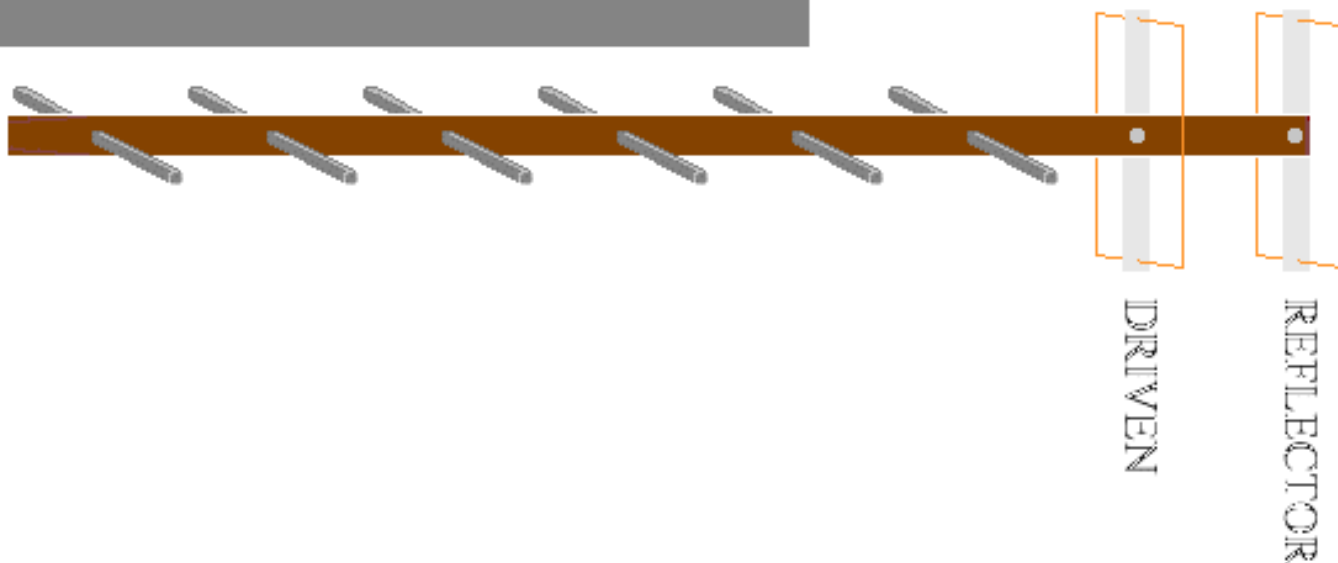

13 DBI GAIN !!

How to build a 432 Mhz Quagi

The boom is made from wood. *{Do not use any type of metal for this.}* The boom length is 61 inches and 1/2 inch thick. Mark the boom as to where the elements are to be spaced and drill a 1/8 inch hole in the center of the boom material. After you have done all this apply a few coats of stain. This will preserve the wood from the abuse of the weather. Use #12 wire to form the quad elements. Cut the wire to the correct lengths (*see chart below*). The quad elements are supported at the top and bottom of the element with a Plexiglas strip with a hole centered at both ends. The bottom of the quad being the feedpoint. Apply a little epoxy to where the wire passes through the support holes. This will secure the wire so it will not move around.

Next solder one end of the wire to the center of an type-N connector feed it through the holes in the Plexiglas and bend it into shape. Then finish the element by soldering the loop closed to the ground tab on the N connector. On the reflector just solder to two ends of the wire together.

The directors are mounted through the boom. Epoxy them as well. They can be made

from any 1/8 inch metal rods. Cut them to the EXACT size (*see chart below...I used stainless steel welding rods which are available at a hardware store*)

NOTE: *At UHF frequencies even 1/8 inch difference in length will make the antenna perform differently.*

| | |
|------------------------|---------------------------------------|
| Element Lengths | |
| Reflector Loop | 28" |
| Driven Loop | 26 5/8" |
| Directors | 11-3/4" to 11-7/16" in 1/16" steps |
| Element Spacing | |
| R - DE | 7" |
| DE - D1 | 5.25" |
| D1 - D2 | 11" |
| D2 - D3 | 5.85" |
| D3 - D4 | 8.73" |
| D4 - D5 | 8.73" |
| D5 - D6 | 8.73" |



COFFEE MUGS
BANNERS
FLAGS and PENS
BUTTONS

D. B. C.
Advertising

<http://www.dbcadvertising.com/>

Custom orders OK!

Click on the banner



© Lowell Enterprises

432 TECH LIST

MOD-----TECH-----FILES NEEDED

SEND VIA EMAIL TO: sixclub@6mt.com

© Lowell Enterprises

VHF/UHF MESSAGE BOARD

CONVERSION OF THE UPX-4 c15.zip

HENRY

HENRY MANUAL AND SCHEMATIC FOR THE 2002A, 2004A, 2006A [henry.zip](#)

© Lowell Enterprises

ICOM

IC 451 UPGRADE (KM1H) [icff.zip](#)

KLM

KLM ECHO 70 432 SSB TRANSCEIVER MANUAL [echo70.zip](#)

ACCESSORIES

A TRANSMATCH FOR 432 (QST 9-81) [fttr.zip](#)

FET PREAMP FOR 2MT AND 432 (73 7-67) [tfet.zip](#)

TRANSISTOR FOR 432 AND 2MT PREAMP (QST 2-66) [sis.zip](#)

© Lowell Enterprises

AMPLIFIERS

432 KW (HORIZONS 3-63) [c11.zip](#)

A PRACTICAL KILOWATT (QST 8-64) [apk.zip](#)

AMP USING A 5894 (QST 7-69) [fenf.zip](#)

KILOWATT AMP (QST 2-66) [ktt.zip](#)

K1FO KILOWATT AMPLIFIER PART 1 (QST 10-79)

IMPROVING THE K1FO AMP PART 2 (QST 7-87) [kifo.zip](#)

60 WATT SOLID STATE UHF LINEAR AMP (QST 7-77) [swlam.zip](#)

A 432 AMPLIFIER (QST 1-76) [amft.zip](#)

ANTENNAS

HELICAL FOR 432 (73 12-81) [f34.zip](#)

A COMPACT HYBRID ANTENNA FOR 2, 432, AND 23CM [as.zip](#)

TWIN QUADS 70CM AND 23CM [an.zip](#)

HIGH GAIN VERTICAL - COLINEAR MADE FROM COAX (REB) [col432.zip](#)

© Lowell Enterprises

LONG PERIODIC 140-450MHZ (QST 6-63) [lp.zip](#)
432 YAGI (QST 4-66) [fya.zip](#)
MINI WHEEL (QST 10-67) [mwh.zip](#)
VHF ANTENNAS (73 11-66) [sta.zip](#)
QUAD-QUAD-QUAD (73 5-67) [qqq.zip](#)
OPTIMUM 432 YAGI PART 1 (QST 12-87) PART 2 (QST 1-88) [ofyg.zip](#)
432 TRANSMATCH (QST 9-81) [ftrm.zip](#)
LONG PERIODIC 2-432MHZ [lpmb.zip](#)

CONVERTERS

© Lowell Enterprises

CONVERTER FOR 432 (QST 3-83) [fttcv.zip](#)

PREAMPS

PREAMP (VHFER 3-67) [c1.zip](#)
FET PREAMP 2MT AND 432 (73 7-67) [tfet.zip](#)

TRANSVERTERS

A HIGH PERFORMANCE 432 TRANSVERTER PART 1 (QST 8-91) see below
-----**PART 2 (QST 9-91) [hfamp.zip](#)**

[BACK TO HOMEPAGE](#)

© Lowell Enterprises

Copyright © 2001 by Lowell Enterprises

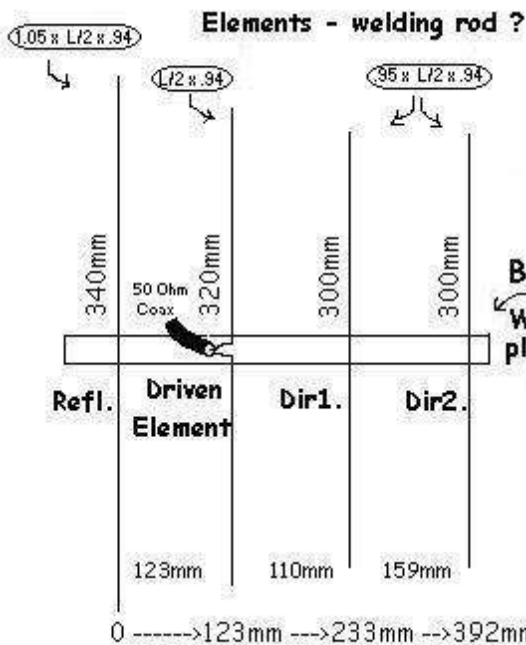

One easy version - uses electrical conduit for boom & galvanised iron coat hanger wire !

Terminal block connector strip makes for great element securing, & neatly connects coax. feed to the 2 parts of the dipole driven els. - each 160mm long.

It all dismantles too- no glue or solder- so suits field use/repairs!

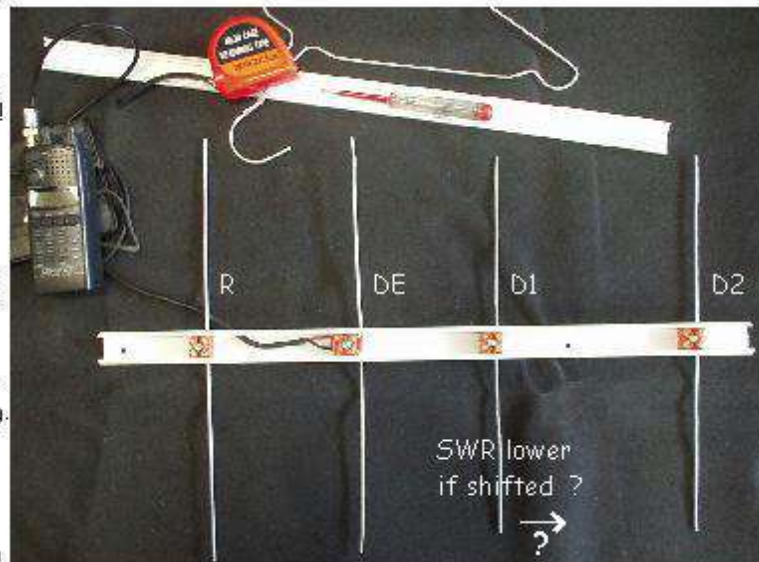

Sourced => www.bl.fr/amatech/electronique/radio/antennes/yagi4/yagi4.htm
 Designed under antenna simulator software - "MININEC" => www.emsci.com

433 MHz UHF Yagi antenna - suitable low power LIPD/ISM "fox hunting"

The 433.92MHz "Low Interference Potential Device" (LIPD) licence free band suits utility devices < 25mW power. A simple 4 element Yagi boosts signals ~ 7dB (= ~ range doubling) + direction finding for nearby signals.

Classic antenna theory, sourced from such Ham texts as the ARRL & RSGB handbooks, assigns the driven element as electrical length = 1/2 a wavelength (shown here L). The actual physical length is somewhat reduced however, by a multiplication factor relating to the diameter of the elements & wavelength of signals in use. At UHF it's typically 0.94. Directors are usually 0.43L, with spacing 0.25L, with improved bandwidth resulting from tapering in the direction of the signal. Gain is not appreciably influenced by rear reflector spacing in the range L/8 - L/4, but useful impedance variation occurs. Hence at 433.92 MHz ...

$$L = c/f = 3 \times 10^8 / 433.92 \times 10^6 = L = 692\text{mm}$$

$$L/2 = 346\text{mm}$$

$$L/4 = 173\text{mm}$$

This is theoretical electrical length

$$\text{Actual cut lengths} \times 0.94 \text{ these so } L = 650\text{mm}$$

$$L/2 = 325\text{mm}$$

$$L/4 = 163\text{mm}$$

For physical length driven element

It's apparent thus that the design shown is a compacted version, & better performance may result from spacings & element lengths closer to theoretical. Check many further resources via => <http://ac6v.com/antprojects.htm>

Stan. SWAN => s.t.swan@massey.ac.nz 6/03

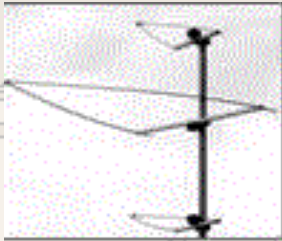

Click on the banner

IF YOU WANT TO ADVERTISE

© Lowell Enterprises



903 TECH LIST

MOD-----TECH-----FILES NEEDED

SEND VIA EMAIL TO: sixclub@6mt.com

© Lowell Enterprises

UPDATED : FEBRUARY 05, 2001

VHF/UHF MESSAGE BOARD

ACCESSORIES

- A 759 MHZ LOCAL OSCILLATOR (QEX 5-88) [q.zip](#)**
- 903 FILTER (KK7B) [l.zip](#)**
- 903 UT-141 FILTER (WA3AXV) [m.zip](#)**

AMPLIFIERS

- SOLID STATE LINEAR AMP FOR 33CM (QEX 6-88) [s.zip](#)**
- 0.5 WATT 903 MHZ AMP (QEX 6-88) [r.zip](#)**
- LOW DRIVER - LOW LEVEL AMP [p.zip](#)**
- 800-950 MHZ LINEAR AMPLIFIER (WA3JUF) [n.zip](#)**
- 2 - 7289s ON 903 (WR1L) [k.zip](#)**
- 902 1 WATT AMP (KF5N) [h.zip](#)**
- A 5 WATT 902 AMP (W5ETG) [f.zip](#)**
- TWO 7289s ON 903 (QEX 4-88) [e.zip](#)**
- CAVITY AMP - HIGH POWER (QST 11-82) [notc.zip](#)**
- LINEAR AMPLIFIER PART 1(QST 6-90)--PART 2 (QST 7-90) [ntla.zip](#)**

ANTENNAS

- DUAL BAND DISH FEEDS (WA5VJB) [o.zip](#)**
- 902 LOOP YAGI (QST 11-85) [i.zip](#)**
- 47 ELEMENT LOOP YAGI [d.zip](#)**
- 38 ELEMENT LOOP YAGI [c.zip](#)**
- 27 ELEMENT LOOP YAGI [b.zip](#)**
- LOOP YAGI ANTENNA (QST 11-95) [nloop.zip](#)**

PREAMP

- 902 PREAMP (KK7B) [a.zip](#)**

TRANSMITTER

- 3 WATT 902 CW TRANSMITTER (K9MK) [t.zip](#)**
- 20+ WATT 902 CW TRANSMITTER (K9MK) [u.zip](#)**
- A CW TRANSMITTER FOR 902 (QST 3-86) [ncw.zip](#)**

TRANSVERTER

TR SWITCHING LOW POWER 903 & 1296 TRANSVERTERS (QEX 7-92) [j.zip](#)
MODIFIED NTMS TRANSVERTER FOR 903 (K9MK) [g.zip](#)
A SIMPLE BOARD NO TUNE 902 TRANSVERTER (QST 7-91) [ntrv.zip](#)

[BACK TO HOMEPAGE](#)

Copyright © 2001 by Lowell Enterprises

© Lowell Enterprises

© Lowell Enterprises

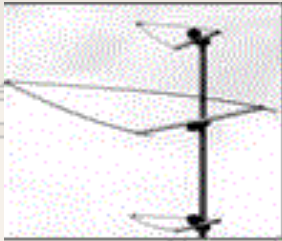

Click on the banner



© Lowell Enterprises

1296 TECH LIST

MOD-----TECH-----FILES NEEDED

SEND VIA EMAIL TO: sixclub@6mt.com

© Lowell Enterprises

UPDATED :FEBRUARY 05, 2001

VHF/UHF MESSAGE BOARD

MICROWAVE MODULE

MANUAL FOR 1296 /144 "MMT 1296" [mm129.zip](#)

© Lowell Enterprises

ACCESSORIES

1296 OSCILLATOR [ar.zip](#)

SURPLUS FILTERS [ak.zip](#)

DUAL DISH FEEDS (WA5VJB) [ag.zip](#)

LIQUID COOLING THE 2C39 (VK7IK) [af.zip](#)

432 - 1296 TRIPLER [ab.zip](#)

TR SWITCHING LOW POWER 903 & 1296 TRANSVERTERS (QEX 7-92) [j.zip](#)

A 2 - SLUG TUNER PART 1 (QST 1-83) SEE BELOW

POWER INDICATOR FOR 1296 SLUG TUNER PART 2 (QST 7-83) [slgt.zip](#)

POWER SPLITTER (QST 2-83) [psprl.zip](#)

A 1296 SIGNAL SOURCE (QST 3-77) [tnsss.zip](#)

© Lowell Enterprises

AMPLIFIERS

MICROWAVE ANTENNA YOU CAN BUILD (73'S 10-82) [aq.zip](#)

30 WATT LINEAR ON 23CM (DUBUS 2-94) [ap.zip](#)

35 WATT 1296 AMP (QEX 6-87) [am.zip](#)

1296 AMP - PART 1 AND 2 AND COMMENTS (KF5N) [al.zip](#)

1296 AMP (TJ TURNER) [aj.zip](#)

LINEAR AMP 1250 (VHF COMM 2-81) [ai.zip](#)

1296 AMP CLASS "C" (WA5JUF) [aa.zip](#)

1296 AMP (QST 1-68) [1296.zip](#)

1296 SOLID STATE AMP (QST 12-85) [tnss.zip](#)

1296 QUARTER KILOWATT AMP (QST 4-85) [quamp.zip](#)

QUARTER KILOWATT CAVITY AMP (QST 3-85) [qucam.zip](#)

© Lowell Enterprises

ANTENNAS

4 FOOT DISH FOR 1296 (HORIZONS 7-63) [c7.zip](#)

A QUICK ANTENNA FOR 1296 (HORIZONS 11-62) [c4.zip](#)

A LONG YAGI ANTENNA (DL3WR) [at.zip](#)

A COMPACT HYBRID ANTENNA FOR 2, 432, AND 23CM [as.zip](#)

DL6WU YAGI FOR 23CM (DUBUS 2-94) [ao.zip](#)

TWIN QUADS 70CM AND 23CM [an.zip](#)

DEEP DISH FEED HORNS VE4MA (DUBUS 4-89) [ah.zip](#)

45 ELE LOOP YAGI (WB5LUA) [ad.zip](#)

1296 FEED HORN ANTENNA (WA5VJB) [ac.zip](#)

A QUAGI FOR 1296 (QST 8-81) [tnqu.zip](#)

A PARABOLIC DISH FEED (QST 1-83) [pdsh.zip](#)

HOME BUILT PARABOLIC REFLECTOR (QST 4-61) [hbp.zip](#)

QUAD HELIX ANTENNA (QST 8-63) [thex.zip](#)

1296 ANTENNA (QST 6-69) [tna.zip](#)

DUAL RHOMBIC REVISITED (QST 3-97) [drhmb.zip](#)

© Lowell Enterprises

CONVERTERS

CLASSIC CONVERTER (QST 12-69) [cc.zip](#)

PREAMPS

3 DIFFERENT PREAMPS (WA5VJB) [ae.zip](#)

A LOW NOISE PREAMPLIFIER (QST 6-82) [tnlnp.zip](#)

A 1296 PREAMP (QST 1-81) [tptns.zip](#)

1296 PREAMP (QST 1-81) [tprea.zip](#)

© Lowell Enterprises

BACK TO HOMEPAGE

Copyright © 2001 by Lowell Enterprises

1270Mhz Yagi Antenna

Build your own antenna for the 23cm band (1250Mhz - 1280Mc) using some aluminium and the following simple design.

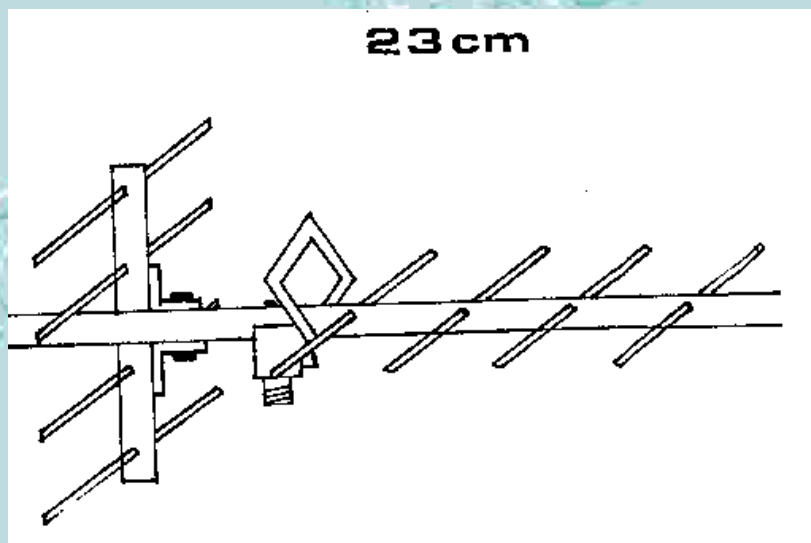

Due to a large number of reflectors front to back ratio is excellent.

The average gain is about +12 dbd.

Broad bandwidth makes this antenna the optimal choice for ATV (television)

23 cm Yagi 13 Elemente ca. 12dbd

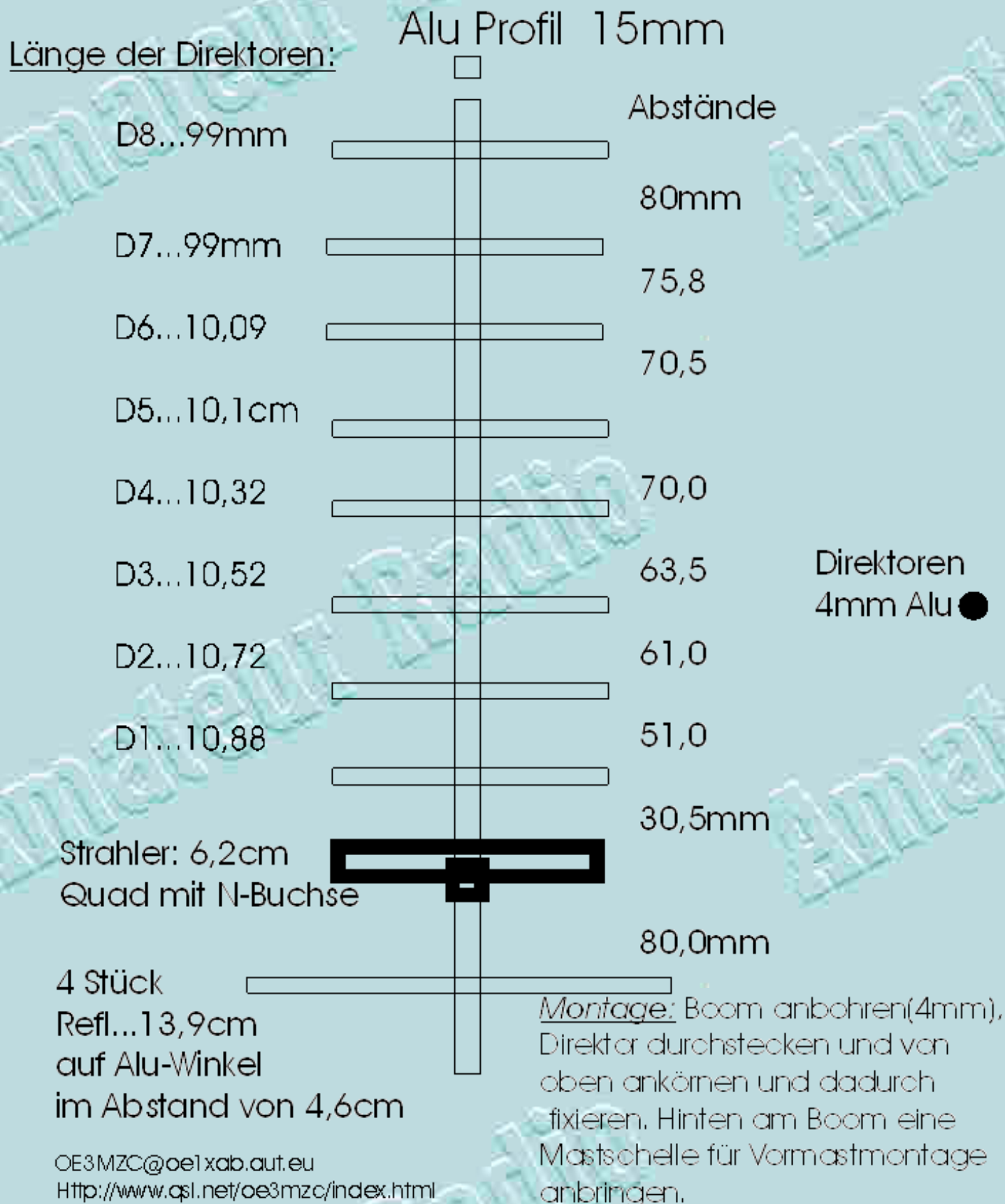

OE3MZC@oe1xab.at.eu
[Http://www.qsl.net/oe3mzc/index.html](http://www.qsl.net/oe3mzc/index.html)

2,4Ghz - 13cm band quadriple Quad with reflector 14dbd gain



Bild 2: Vierfach-Quad für 13 cm (Gewinn 14 dB bei 1% Maßhaltigkeit, Draufsicht analog Bild 1)

Double Quad antenna

for 23cm band 1,2Ghz

homemade

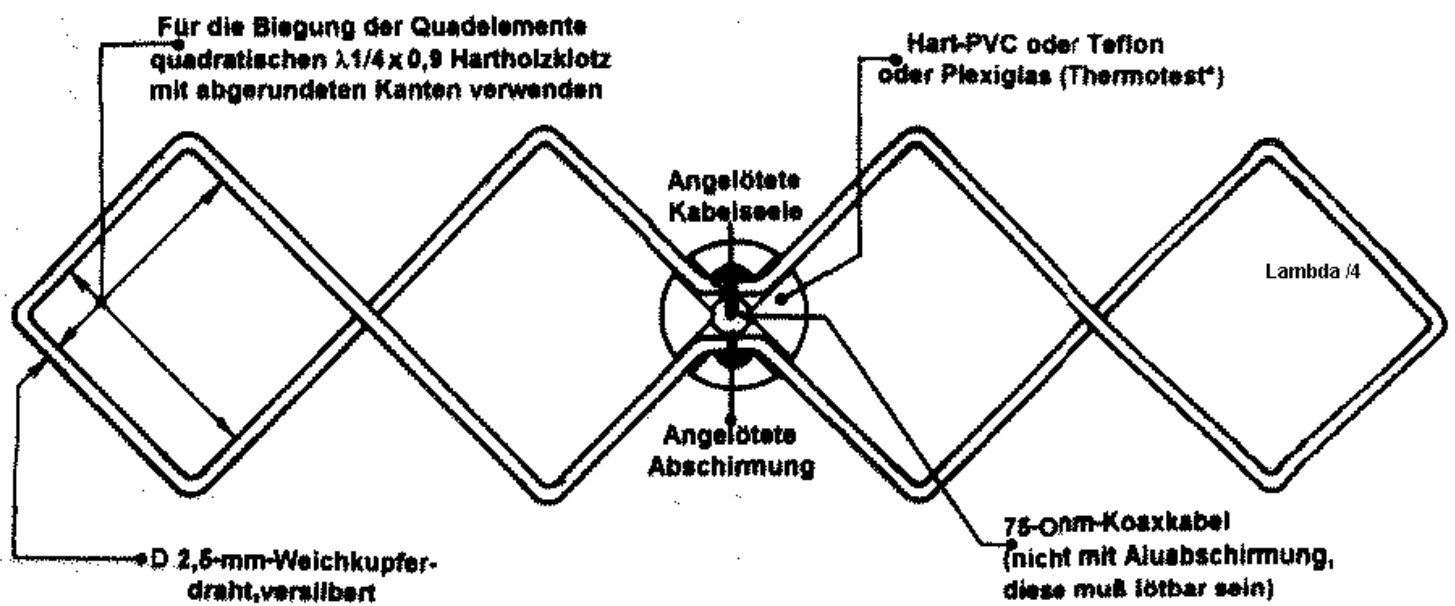
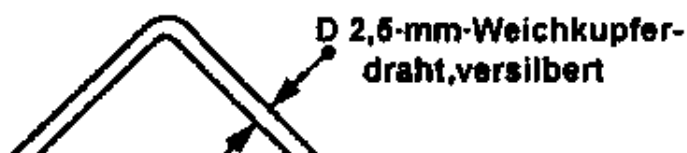

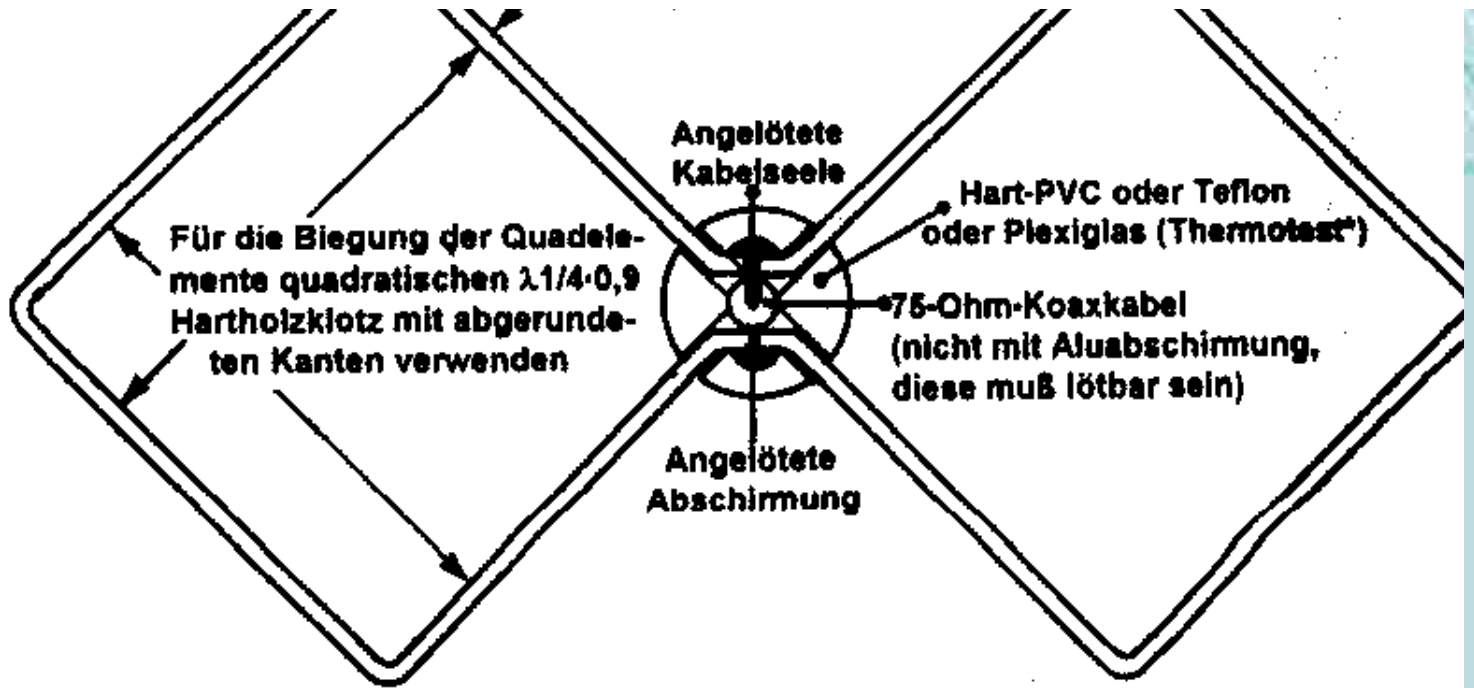

Antennen-Einspeisemitte
im 2mm-Kreuzkanal nach
Vorwärmung mit Heiß-
luftkleber versiegeln

D 2,5-mm-Weichkupfer-
draht, versilbert

Antennensystem wird von dem
kupferkaschierten Reflektor $1\lambda \dots 1,5\lambda$
aus Pertinax oder Epoxid getragen

Abstand auspro-
zwischen $\lambda/8$ u

Angelötete
Abschirmung

4 Messingwinkel an die
Kaschierung symmetrisch
angelötet.

Gartenschlauchschele

Bohrung entsprechend fester
Passung des Koaxkabels

Hart-PVC oder Teflon
oder Plexiglas (Thermotest*)

70

20

Ø

HERMOTEST: Der Isolierstoff-Prüfling
in der Haushaltsmicrowelle ca. 10 Min.
eingesetzt. Erwärmt sich der Prüfling
sichtbar, so ist die Verwendung ab
1GHz nicht zu empfehlen.

! 1: Doppelquad für 23 cm (Gewinn 14 dB bei 1% Maßhaltigkeit)



AR-RING
The easy way to tour Amateur
Radio Sites on the Web!

**AR-Ring
Home Page**

Previous **Next
Five**

**N
E
X
T**

[top of page](#) | [home](#) | [propagation](#) | [field strenght meter](#) | [Tone Decoders -CTCSS](#) | [Maldives Dxpediton](#) | [Webreceivers](#)

You are visitor number:

135536

Greg's Wireless Networking (WiFi) Info Page

- Results of my first [Homebrew WiFi Antenna Shootout](#)
- How to [Build a Tin Can Waveguide WiFi Antenna](#)
- My [Presentation](#) to the [Bellingham Linux Users Group](#) (BLUG) Wireless Special Interest Group Meeting
- My Wireless [Bookmarks](#)
- [Quicktime](#) Video of [Pringles Can Antenna](#) from [AirShare.org](#)



[SardineCanAntenna](#)

[UserPreferences](#)

[SeattleWireless](#) [FrontPage](#) [RecentChanges](#) [TitleIndex](#) [WordIndex](#) [SiteNavigation](#) [HelpContents](#)



<-- Back to [AntennaHowTo](#)

Sardine Can Antenna. is a [BiQuad](#) or Bi circle - wire length each side (8 x 1/4 waves) 31 mm



Sardine cans have quite standard dimensions around the world, although the oval one shown here is lightweight aluminium & does seem (perhaps by chance ?) to have enhanced directivity compared with more normal steel Canadian "Brunswicks " etc. It's an ex. Latvian RICHTER "Smoked RIGA SPRATS" & perhaps first received publicity in the Nov. 2002 Australian "Silicon Chip" monthly (author Stan. SWAN => s.t.swan@massey.ac.nz), when it was first called a "Kipper Can". (For those readers who don't recall Monty Python, Kippers are smoked herrings http://www.deliaonline.com/ingredients/ingredientsatoz/i_0000000135.asp. See refs & further construction dimensions/views/insights => <http://www.manuka.orcon.net.nz> <= Even an old CD can act as the reflector, exploiting the metalised layer of course, but the sardine version proved far superior, no doubt due to the focusing side walls.

The hot melt glue shown here is not really needed if a rigid N connector is used, although a recent enhancement has been to form the radiating bow tie as tracks on a small PCB secured via nylon spacers. Gain is great -typically 10dB (links to 10km LOS made & typically 2km more normal built up areas !).

Need a quicke antenna ? Got 10 minutes & simple tools ? You won't get a simpler, cheaper or more compact design. The unit can be neatly hidden in a pencil case or plastic bag beside your road warrior notebook so it's not intimidating for field use. It's directional enough to even pin point the signal location (using [NetStumbler](#) etc) in a multilevel building. RECOMMENDED !

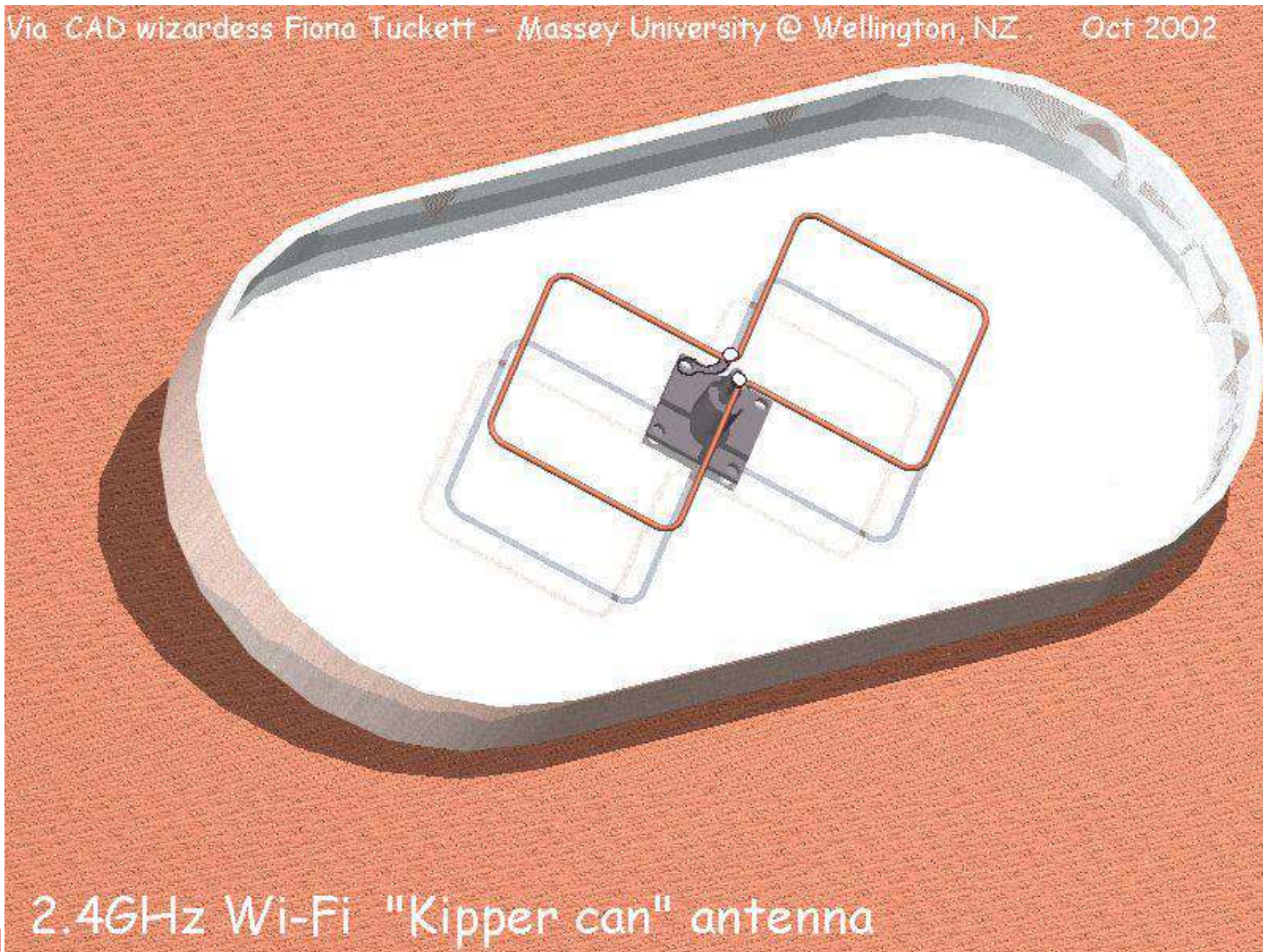

□ 2.4GHz Wi-Fi "Kipper can" antenna

Double Quad "Bow Tie" antenna for 2.4 GHz Wi-Fi range extension

Reflector approx. 150mm dia. round
or oval, & with 31mm sides ?



Gain: (relative to half-wave dipole)

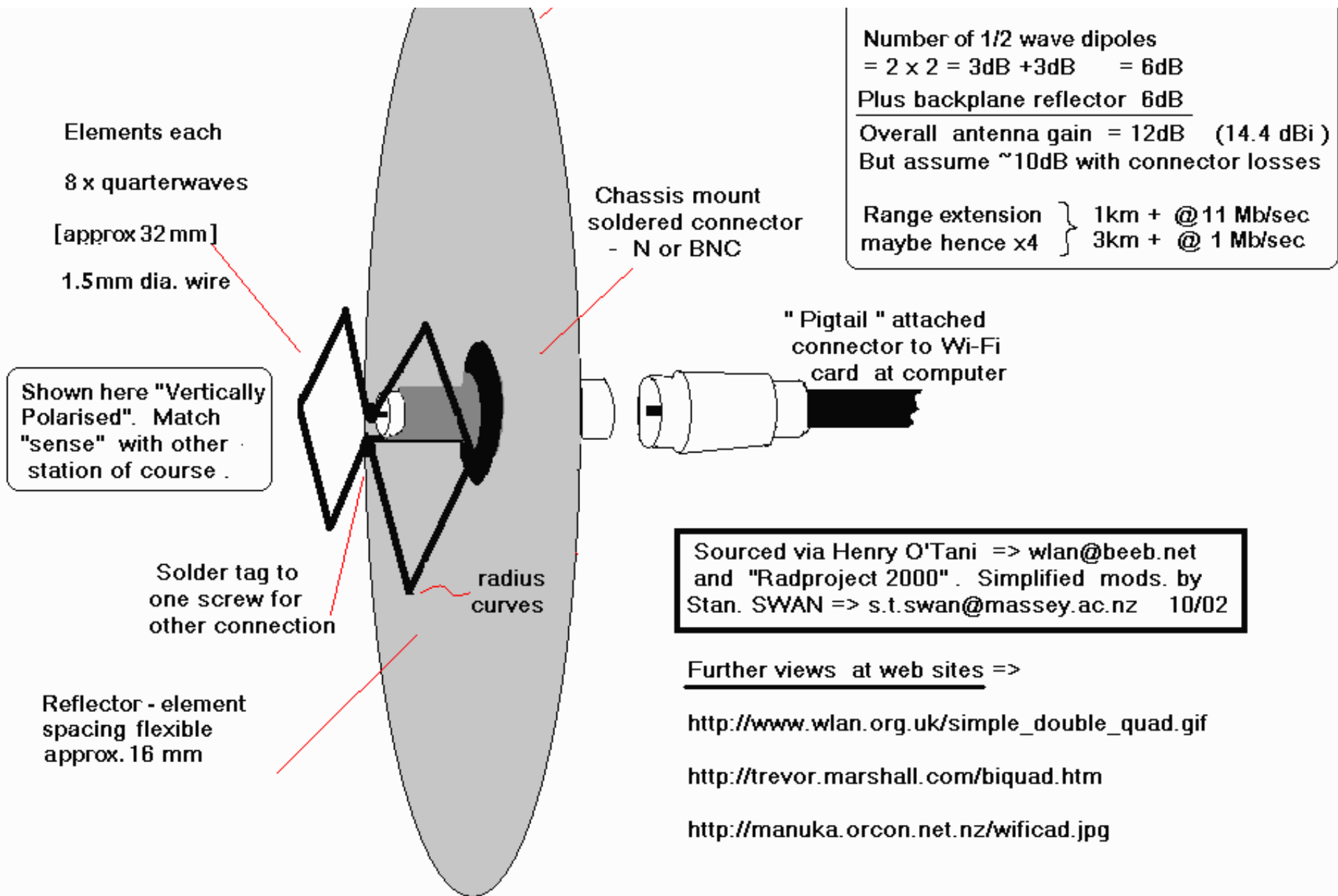

Number of 1/2 wave dipoles
= 2 x 2 = 3dB + 3dB = 6dB
Plus backplane reflector 6dB
Overall antenna gain = 12dB (14.4 dBi)
But assume ~10dB with connector losses

Range extension } 1km + @11 Mb/sec
maybe hence x4 } 3km + @ 1 Mb/sec

Shown here "Vertically Polarised". Match "sense" with other station of course .

Sourced via Henry O'Tani => wlan@beeb.net and "Radproject 2000". Simplified mods. by Stan. SWAN => s.t.swan@massey.ac.nz 10/02

Further views at web sites =>
http://www.wlan.org.uk/simple_double_quad.gif
<http://trevor.marshall.com/biquad.htm>
<http://manuka.orcon.net.nz/wificad.jpg>

[EditText](#) of this page [current page size **1923** bytes] (last edited 2004-07-12 22:18:59 by 80.58.6.235.proxycache.rima-tde.net)

[FindPage](#) by browsing, title search, text search or an index

Or try one of these actions: [LikePages](#), [LocalSiteMap](#), [SpellCheck](#)

Bandwidth Provided By:



Construcción de una antena direccional

Loop-Uda-Yagi para 2.4 Ghz.

Por [Inco](#)
Fotos : Gonzalo



El diseño de esta antena se basa en otros encontrados en internet y sobre todo en los datos obtenidos con el programa de G6KSN [loopyagi.exe](#) antes alojado [aquí](#) y que sirve para calcular antenas loop-uda-yagi para cualquier frecuencia. Las dimensiones y la forma de construirla se han cambiado levemente para adaptarnos a los materiales que teníamos a nuestro alcance. Es una antena muy direccional y con ganancia bastante alta, 14dbi. La polarización horizontal o vertical depende únicamente de la posición en que fijas la antena.



Figura 1: Esquema de la antena original de G6KSN

Los resultados obtenidos con [loopyagi.exe](#) para una frecuencia de 2441Mhz son los siguientes :

| Elemento | Dimensiones | Distancia desde el reflector1 |
|-------------|----------------------|-------------------------------|
| reflector 1 | 123mm diametro | 0 mm |
| reflector 2 | 135mm circunferencia | 42 mm |

Haciendo Loop-Uda-Yagi

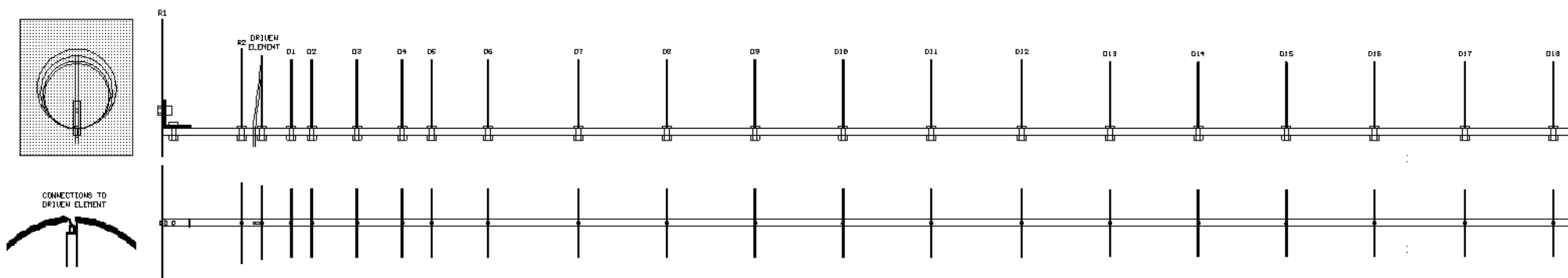
| | | | |
|-------------|-------|----------------|--------|
| alimentador | 123mm | circunferencia | 55 mm |
| director 1 | 114mm | circunferencia | 70 mm |
| director 2 | 114mm | circunferencia | 81 mm |
| director 3 | 114mm | circunferencia | 105 mm |
| director 4 | 114mm | circunferencia | 129 mm |
| director 5 | 114mm | circunferencia | 146 mm |
| director 6 | 114mm | circunferencia | 177 mm |
| director 7 | 114mm | circunferencia | 225 mm |
| director 8 | 114mm | circunferencia | 273 mm |
| director 9 | 114mm | circunferencia | 321 mm |
| director 10 | 114mm | circunferencia | 369 mm |
| director 11 | 114mm | circunferencia | 417 mm |
| director 12 | 114mm | circunferencia | 465 mm |
| director 13 | 110mm | circunferencia | 513 mm |
| director 14 | 110mm | circunferencia | 561 mm |
| director 15 | 110mm | circunferencia | 609 mm |
| director 16 | 110mm | circunferencia | 657 mm |
| director 17 | 110mm | circunferencia | 705 mm |
| director 18 | 110mm | circunferencia | 753 mm |
| director 19 | 110mm | circunferencia | 801 mm |
| director 20 | 110mm | circunferencia | 849 mm |
| director 21 | 106mm | circunferencia | 897 mm |
| director 22 | 106mm | circunferencia | 945 mm |

El radomo (palo al que van soldados el resto de los elementos) es un tubo de cobre, usado en fontanería, de 12mm de diámetro. Los elementos en forma de anilla están hechos a partir de un alambre de cobre de 1.5mm de diámetro.

Dependiendo de la ganancia que queramos conseguir tendremos que hacer la antena mas o menos larga, aquí damos las instrucciones para hacer una de aproximadamente 1 metro de longitud y 22 directores, que da una ganancia aproximada de 14Dbi. Si se quiere hacer una antena de menor ganancia basta con acortarla hasta donde deseese, por ejemplo, una antena de 50cm y 11 directores tiene una ganancia de aproximadamente 11Dbi. Como orientación decir que en las pruebas realizadas se obtuvieron ganancias de 7db (la de 22 directores) y 4db (la de 11 directores) por encima de los resultados obtenidos con una antena tipo bote (de 8.7 cm de diámetro y 16.5cm de longitud).

Empezaremos haciendo las anillas, quitamos la funda aislante del cable de cobre, y a continuación enrollamos el alambre sobre un trozo de tubo de cobre de 35mm de diámetro, hasta hacer 12 vueltas completas. Fijamos el alambre con alguna cinta adhesiva y con una cuchilla, dando varias pasadas, hacemos una marca a todas las anillas. Saltamos la cinta, retiramos el alambre del tubo de cobre y vamos cortando cada anilla por las marcas que hemos hecho. Se manipulan las anillas hasta conseguir que formen un círculo completamente cerrado. Estas doce anillas serán los primeros alimentadores numerados del 1 al 12.

El paso anterior lo repetimos enrollado el cable sobre un tubo de 34mm de diámetro, (nosotros utilizamos un tubo de una aspiradora). Sobre este tubo hacemos ahora otras 10 espiras, las marcamos y cortamos. A dos de éstas les cortamos 4 mm, para utilizarlas como directores 21 y 22, las restantes 8 anillas serán los directores del 13 al 20.

Medimos dos trozos de alambre de cobre, uno de 123mm y otro de 135mm para hacer el Alimentador y el Reflector 2 respectivamente. Les daremos también forma circular enrollándolos sobre un tubo de 40mm de diámetro y rematando la forma a mano.

Cortamos el tubo de cobre que formará el radomo, la longitud depende del número de directores de la antena que nos propongamos hacer. Para la de 22 directores lo cortaremos a 102 cm, es decir, 7.5cm mas largo que la medida que nos indica la tabla (Director 22 945mm).

A continuación sujetamos, con alguna herramienta o cinta adhesiva, una cinta métrica al tubo de cobre y le hacemos las marcas en las que irán soldados los distintos elementos. Comenzamos haciendo una marca a 7cm de uno de los extremos. Esta marca la tomamos como origen o "cero" para le resto de las medidas, o sea, en ella irá soldado el Reflector1. A 42 mm del "cero" haremos la marca para el Reflector2, a 55 mm del "cero" haremos la marca para el Alimentador, a 70 mm del "cero" la marca para el Director1, a 81mm la del Director2 y así hasta llegar al Director22.

Ya sólo nos queda soldar cada elemento en su sitio. Empezaremos por el último director, el 22. Para esto hemos preparado una herramienta o pinza que se puede desplazar por el tubo de cobre y tiene unos brazos que permiten sujetar firmemente una arandela en su posición correcta mientras la soldamos. La soldadura la hacemos con soplete de fontanero, aplicando previamente decapante o flux en las piezas a unir. Tanto los directores, como el Reflector2 se sueldan con la abertura de la anilla en contacto con el tubo de cobre, de modo que al soldar la anilla al tubo queden también unidos los extremos de la anilla.

El Director se suelda de forma que la ranura quede diametralmente opuesta al punto de unión de la arandela al tubo. En los extremos sueltos del Alimentador soldaremos posteriormente el cable coaxial, la malla a uno de los extremos y el vivo al otro. Soldamos a continuación el Reflector 2.

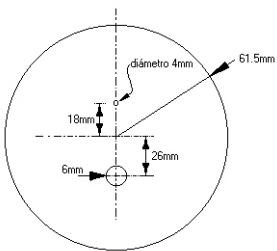

El Reflector1 es un círculo de 123mm de diámetro de chapa de latón de 0.5mm de espesor. Se marca con compás o plantilla y se corta con la tijera para chapa. En este reflector hacemos dos agujeros, uno con centro a 26mm del centro del reflector, y de 12mm de diámetro, en este agujero soldaremos el radomo. Hacemos otro agujero, de 4mm de diámetro y con centro a 18mm del centro del reflector. En este agujero soldaremos un trozo de tubo de latón de 4mm de diámetro y de 60mm de longitud. Por el interior de este tubo se introduce el cable coaxial RG-316, soldamos el cable coaxial al Alimentador y en el otro extremo del cable le colocamos el conector apropiado, dependiendo a que aparato Wifi vayamos a conectar la antena.

Herramientas que necesitas:

- Un cortatubos o un arco de sierra para metales.
- Unas tijeras para cortar chapa.
- Unas tenazillas para cortar los cables, la tijera de chapa puede servir.
- Un soplete, estaño y flux.
- Estaño y un estañador, si es de 100wattios mejor que el de 40wattios.
- Un tornillo de banco para sujetar las piezas mientras las sueldas.
- Tubos de diferentes diámetros para enrollar las anillas (35mm, 34mm, 40mm)

Donde conseguir los materiales:

- El cable de cobre de 1.5mm de diámetro en cualquier tienda de material eléctrico.
- El tubo de cobre de 12mm de diámetro en cualquier almacén de material de fontanería o incluso en grandes superficies dedicadas a bricolage.
- La chapa de latón la he comprado en Suministros Azán, en el polígono de Argales en Valladolid. Cuesta unos 28 euros una plancha de 100x60cm aprox.
- El tubo de latón de 4mm y la varilla de latón de 4mm de diámetro o similar (para hacer la pinza para sujetar las arandelas) en grandes superficies de bricolage o en tiendas dedicadas a maquetas y modelismo, como Biplano al lado de San Benito, en Valladolid.
- El RG-316 se encuentra en [amidata](#) en Madrid, en bobinas de 25 metros.

Haciendo Loop-Uda-Yagi

- El conector N macho para soldar a cable (para rg-58, no se encuentra para cable mas fino) en cualquier tienda de componentes electrónicos, en Valladolid en Oseca, en la carretera de circunvalación. También en Oseca la abrazadera para sujetar la antena a un mástil.
- La chapa perforada para hacer el soporte de la antena se compró en AKI en el Camino Viejo de Simancas, pero puede servir cualquier otra chapa de 2mm de grosor y tamaño 7cmx15cm.

Brought to You by [Art Winterbauer \(WA5OES\)](#)

The Condo Communicator is a newsletter directed toward helping hams solve the perennial problem of getting on the air from inside apartments, townhouses and anywhere that the traditional big-tower setup is forbidden or impractical. Dormitory residents and anyone not living on 40 acres in the country will find the suggestions in these articles helpful. Enjoy!

- [The Condo Communicator - Issue 1](#)
- [The Condo Communicator - Issue 2](#)
- [The Condo Communicator - Issue 3](#)
- [The Condo Communicator - Issue 4](#)
- [The Condo Communicator - Issue 5](#)
- [The Condo Communicator - Issue 6](#)
- [The Condo Communicator - Issue 7](#)

This has previously been circulated on packet radio and in a modified form on Hap Holly's R.A.I.N. (Radio Amateur Information Network). Enjoy!--WA5OES



Ham Radio Operators ID Badge

Engraved with Your Name, Call Sign [Click Here](#)



Find on this site...

[Exams](#) Search site: Call sign search:
[Clubs](#)
[Hamfests](#)
[Addresses](#)

Site Index

ARRL Member Login...

Username: Password:

[Register](#)

Quick Links...

[Join or Renew](#)
[Catalog & Store](#)
[ARRL Courses](#)
[Classifieds](#)
[Getting Started](#)

[Operating Activities](#)
[Licensing](#)
[News/Bulletins](#)
[Services](#)
[Educational](#)
[Public Service](#)
[Support](#)
[Donate to ARRL](#)
[ARRL Info](#)
[Text-only/Printable](#)

"But I Never Agreed to That!"

Covenants, Conditions and Restrictions in the Amateur Service

By Chris Imlay, W3KD
ARRL General Counsel

From December 1995 *QST*

[PRB-1](#) · [Regulatory Information Branch](#)

- [How Do Covenants Differ From Zoning Ordinances?](#)
- [So Who Enforces These Covenants?](#)
- [Antenna Covenants](#)
- [How About PRB-1?](#)
- [What's in the Future?](#)

Jim Rich, WD6CJB, woke up one morning to find that, during the night, someone had accidentally crashed a car through his fence. That wasn't much of a problem all by itself--the insurance company would cover the fence repair--the unfortunate part was that Jim's multiband HF dipole antenna that was mounted on the inside of the fence, was destroyed. The dipole had not been effective for what Jim Rich wanted to do in Amateur Radio--emergency and public service work--so he figured that it was time to put up something better anyway. That decision began the nightmare that Jim didn't have the night before.

Jim And CC&Rs

Jim went to the zoning authorities for the City of Foster City, a group of subdivisions in a planned community south of San Francisco, and asked for a building permit for a 35-foot crank-up antenna support and a small triband Yagi antenna. He was promptly denied such; the mayor and council members went out of their way to keep this "scourge" out of the neighborhood. They were not successful, because the zoning ordinance in Foster City was plainly preempted by

ARRL Products:

CD-ROMs

[\(More\)](#)



[NCJ Collection CD-ROM 1973-1998](#) --

Back issues of *NCJ*, the National Contest Journal, on a convenient, space-saving CD-ROM.



[Ham University-- Technician Edition](#)

-- Feature packed, easy-to-use software for Technician exam training. Pass your first license exam, *FAST!* Microsoft Windows compatible.



[Ham Radio CD-ROM set](#) -- Enjoy

back issues of **Ham Radio** magazine, published from 1968 to 1990.



[Ham University](#) --

Learn Morse code with this feature packed easy-to-use software. Also includes a written exam quiz generator with all three question pools. Microsoft Windows compatible.

the FCC's Amateur Radio Preemption policy.[\[1\]](#) The thing about Foster City, though, was that when it was first formed, there was not any zoning ordinance (or local government) in the town. Instead, all of the subdivisions had identical declarations of covenants--often called deed restrictions, or "CC&Rs" (covenants, conditions and restrictions)--that governed land use in each subdivision. When the town adopted zoning ordinances to deal with land use details, the homeowner's associations in the Foster City subdivisions gradually faded away. They were no longer necessary.

The covenants, although dormant, were still in place, and they bound each successive purchaser of land in Foster City. The covenants provided, as do most, that any home-owner could enforce them against any other homeowner. And in Foster City, the CC&Rs prohibited all antennas of every type that are outside the house, above the roof, and not under the eaves. The restriction is absurd, as a practical matter--there are television antennas on numerous houses. When the City of Foster City found out that it couldn't prohibit Jim Rich's modest antenna system, Jim got his building permit. However, the municipal government did all it could to encourage the formation of a group of neighbors (most of whom can't even see Jim's antenna) to enforce the long-dormant and unenforced covenants against Jim. Thus began about four years of litigation. Jim's case ate up thousands of dollars of Jim's money, caused untold emotional impact on Jim and his wife, and resulted in many hundreds of hours of donated time by two very dedicated and talented ham lawyers in northern California [\[2\]](#) in the efforts to protect Jim's ability to install and keep a modest 35-foot crank-up antenna.



TravelPlus for Repeaters CD-ROM -- Now

Shipping! -- 2004-2005 Edition. Locate repeaters along your travel route. Detailed maps and current repeater data. New, improved, and updated version.

How Do Covenants Differ From Zoning Ordinances?

Many hams are not aware of the differences between zoning ordinances and covenants. The two are radically different in terms of their legal status and how they are likely to affect an amateur. It is useful to understand covenants not only from the viewpoint of the ham who appears to be at the mercy of his or her neighbors, but as well as from the point of view of the real estate developer, who has created the problem for the radio amateur in the first place.

Suppose you are a real estate developer, who looks forward to a financially successful subdivision development project. Financing a subdivision and the construction of houses requires that you borrow money from a bank. You then acquire the land for the subdivision, file a subdivision plat with the county or city, and begin construction of houses. Your interest is in getting your houses built and sold quickly, so you can pay off the bank, pocket your profits, and move on to the next project. The process of selling off the houses in your subdivision, however, may not go as fast as you would like, and perhaps you have to keep a few houses for some time. Since the last few houses sold represent, for the developer, the profit in the subdivision project (the bank has to be paid off first), what you don't want is for one of the earlier purchasers of a house in the subdivision to paint pink camels on the front of his house before you can sell off all remaining houses. Some potential home buyers might find the camel paintings unattractive. That would make it difficult for you to sell the last few houses. But what can you do to prevent the pink camel painting? You already sold the painter his house. It isn't yours anymore, and the zoning ordinances don't address pink camel painting.

The answer comes from the old English common law, from where have derived our law and procedures for property ownership and land transactions. Covenants have been placed on land for many years, and have evolved as a means of private land use restriction. Some covenants, in addition to regulating the use of the land itself, seek to regulate even the behavior of those who own the land.[\[3\]](#) Covenants are created when the developer files, with the land records, and usually together with his or her subdivision plat at the time land is subdivided for development, a declaration of covenants. These restrictions on the use of land are applicable to all parcels of land in the subdivision. So, just by buying the land, a buyer becomes subject to the restrictions applicable to the property bought.

Simply stated, covenants are promises that the buyer of land makes as a condition of purchasing the land in the first place, from either a developer or a previous owner. Because the covenants are filed with the land records in the county or city where the land is located, and because they are referred to in your deed, you aren't even required to be fully aware of the specifics of the covenant restrictions when you go to closing on the land.^[4] Since they show up in the "chain of title" to your land, the buyer of the land has what is called "constructive notice" of the covenants, and therefore he or she is charged with the knowledge of them. In other words, you are expected to know what is in the covenants, even though you may not have actual knowledge of the restrictions in them. In many states, this is enough all by itself to require that the buyer comply with all of their provisions. The situation is another expression of the concept that "ignorance of the law is no excuse."

So Who Enforces These Covenants?

Initially, the developer retains the rights to enforce the covenants, since they are to his or her benefit in the first place. Remember that the developer wants the homes in the subdivision to pretty much stay the same, in terms of appearance, until he or she can sell off all the houses and take his or her profit and go on to the next development project. After that, the normal provision is for the enforcement authority to be delegated to a homeowner's association or an architectural control board formed by the declaration of covenants. Sometimes these associations exist for a while and then disappear. If there is no association, does the enforcement authority disappear as well? Sadly, no. In most states, individual homeowners, who are supposedly benefited by the covenants, also have the right to enforce the covenants as well.

Antenna Covenants

Covenants regulating antennas come in various forms. According to studies commenced by creative communications lawyer and professor Wayne Overbeck, N6NB, antenna covenants take three typical forms: (1) covenants that prohibit all outdoor antennas, (2) covenants that prohibit all radio transmitting devices on the premises, and (3) those that require, prior to installing any "structure" outside the house, the approval of the homeowner's association.

Suppose you buy a house in a subdivision subject to CC&Rs and then become a ham and want to put up an antenna. If you can't get the approval of the association to do so, what do you do? Simply putting up an antenna in violation of the covenants is not necessarily a good plan, because many homeowner's associations, funded by regular, mandatory dues from homeowners in the subdivision (as provided in the declaration of covenants) are charged with the enforcement of the covenants, and are financially able to bring a lawsuit against you to do just that. Indeed, if they don't bring an enforcement suit against you, other neighbors might sue the association for failing to do its job. The worst part about it is that, if you are sued by the association and lose the case, or if you sue the association and lose, attorney's fees incurred by the association (and occasionally, fees incurred by individual home-owners) are, according to many covenants, assessed against you. If you don't pay the fees, the debt continues to haunt you in the form of a lien on your property.

There are common-law defenses against covenants, but they are not used very much, and their effectiveness has been reduced over the years. However, if there are multiple violations of an antenna covenant in a neighborhood (such as the unchallenged existence of other amateur antennas, CB antennas, satellite dishes, or television antennas), then that is good evidence that the covenants prohibiting antennas are abandoned or waived. If you are told by the association that an antenna installation will be acceptable, that approval, if you can prove that it was given, makes enforcement of the antenna covenant difficult for the association later. And if you have an antenna up for a number of years in violation of the covenant, and if it is visible and obvious to others during that time, it is unlikely that the covenant could be enforced at a later date. But beware of these defenses, as they are not absolutely available. Jim Rich noted in

his case that there were antennas in the neighborhood, but the judge decided that they were minimal by comparison to his 35-foot crank-up tower and standard triband Yagi, and did not constitute a waiver or abandonment of the covenants.

How About PRB-1?

Nor does the FCC's PRB-1 preemption order apply to covenants. It specifically disclaims any application to covenants, which FCC describes as "private contractual agreements." It said that "Such agreements are voluntarily entered into by the buyer or tenant when the agreement is executed and do not usually concern this Commission."^[5]

Why would the FCC conclude that PRB-1 did not apply to covenants, while it did apply to zoning ordinances? Surely, covenants that preclude antennas have the exact same effect on the strong Federal interest in promoting Amateur Radio communication as do zoning ordinances. Remember, though, that zoning ordinances are actions of local government, imposed to protect the health, safety and general welfare of the public. State and local laws may be preempted by the Federal law, where the state laws conflict with the Federal law, according to the Constitution of the United States. Covenants, on the other hand, are not governmental actions. They are, in theory, private "agreements" between a buyer and a seller of land. Therefore, they are insulated against intrusion by the Federal government.

There are exceptions to this, however. Racial covenants were declared invalid in 1948 in a famous Supreme Court case called *Shelley v. Kraemer*.^[6] There, the Supreme Court said that where the state courts were called on to enforce a covenant, those covenants that violate a fundamental right should be held invalid. If the FCC had said nothing about covenants in the preemption policy of PRB-1, it might be argued that the "strong Federal interest" in amateur communication is sufficient to support preemption of covenants. However, the Commission's disclaimer of an interest in covenant preemption has made that argument difficult.

The FCC explained its rationale for avoiding the preemption of covenants in PRB-1 by saying that "Purchasers or lessees are free to choose where they wish to reside where such restrictions on amateur antennas are in effect or settle elsewhere." Is that so? Tell that to a person attempting to purchase a home in any of hundreds of other cities in the United States. Studies by Overbeck, N6NB, and others showed that virtually all new housing developments in metropolitan Los Angeles, for example (most less than 20 years old), were subject to antenna covenants. The assumption of the FCC (and of the courts that routinely enforce covenants now) is that it is possible to purchase a home without covenants, so the purchase of a home with covenants is a voluntary act. The assumption fails, however, where the covenants cannot be avoided, subjecting the amateur to having to purchase a house with covenants, or else endure a two-hour commute to work each morning in order to pursue Amateur Radio. There simply is no choice in most metropolitan areas these days, and the situation is getting worse all the time.

What's in the Future?

FCC is now reevaluating its land use preemption policies. It is looking at satellite dish preemption again, and soon will consider preemption of local restrictions on cellular and PCS antennas. FCC has promised to revisit its amateur preemption policies at the same time. It would be reasonable in that context for the Commission to state that it has no less interest in the effective performance of an amateur station merely because it is regulated by covenant restrictions rather than zoning, and at least allow the amateur to make his or her own argument, in the courts, that certain covenants may be preempted.

Until then, the best solution to the covenant problem is to avoid purchasing a house with deed restrictions, or make your offer on the house contingent on your ability to install a reasonable antenna. Put the burden of getting that

approval on the seller. If you are already in a subdivision with deed restrictions, get on the board of the home-owner's association and use some politics. Meanwhile, the League will continue to work for some regulatory reform to deal with antenna covenants and other deed restrictions. If you have a covenant problem, let the Regulatory Information Branch at Headquarters know about it.

And What Happened to Jim Rich?

Just before press time, and after over seven years' struggle, Jim's antenna case is finally over. A settlement was reached on October 10, whereby Jim will pay the plaintiffs \$6,000 of the \$13,000 in fees awarded by the trial judge, both sides will dismiss their appeals, the plaintiffs will release the lien they had on Jim's home, and plaintiffs will not complain about the wire antenna Jim has strung along his fence at a height of five feet.

The trial judge determined that the FCC had the ability to deal with the CC&R issue, but that they had ducked the issue with a footnote in PRB-1. The judge concluded that it was not appropriate for the court to overturn well-settled land law use to address something the FCC itself was unwilling to address.

Rusty Epps, W6OAT, who supplied this late-breaking information, commented that "No one is happy with the settlement terms, so that probably means that it's a pretty good compromise solution!"

Notes

[1] See, PRB-1, 101 FCC 2d 952 (1985), codified at 47 C.F.R. §97.15(e). See also, Chris Imlay, N3AKD, "PRB-1, Seven Years Down the Road," *QST*, Oct 1992. pp 35-37.

[2] The trial law skills of Kip Edwards, W6SZN, and Rusty Epps, W6OAT, and their amazing tenacity and generosity, are stories in themselves.

[3] A good example of this is the prohibition of parking recreational vehicles or boats, or even cars with antennas, in the driveways of houses in subdivisions with CC&Rs.

[4] This is changing by statute in many states; now, it is often required that a buyer of land be given a copy of the CC&Rs prior to closing, at least when buying from a developer.

[5] *Amateur Radio Preemption*, *supra*, footnote 6.

[6] 334 U.S. 1 (1948). For a good analysis of the arguments in favor of Federal Preemption of CC&Rs governing antennas, see Sid Leach, Esq, K5XI, "Federal Preemption of Deed Restrictions," *The DX Magazine*, May/June 1993, pp 36-40.

Page last modified: 01:07 PM, 06 Feb 2003 ET

Page author: webmaster@arrl.org

Copyright © 2003, American Radio Relay League, Inc. All Rights Reserved.

K3QK's



Tower Talk and Legal Resources -for hams with towers.... -and those who are planning them.



Welcome! I have been searching the net for months now, looking for legal resources that hams can use for that "tower project". I have all the documents contained in the ARRL "legal packet", and was hoping to find them posted somewhere. With the exception of PRB-1, I have not. As a service to fellow amateurs, I have decided to post them here. Some of my own ramblings and experiences can also be found here. I welcome your comments, suggestions, questions, and answers. If relevant, they will also be posted here on a regular basis.

-Good luck with that tower project! 73, de Gregg, K3QK

[-My own experiences with towers and local government officials](#)

[-Chronological List of Landmark Amateur Radio Case Cites](#)

[-Memorandum Opinion and Order in PRB-1 \(from ARRL Web Site\)](#)

[-PRB-1, The FCC's Limited Preemption of Local Ordinances \(from ARRL Web Site\)](#)

[-John Thernes vs. City of Lakeside Park](#)

[-John Thernes vs. City of Lakeside Park-Consent Decree, Order, and Final Judgement](#)

[-Andrew B. Bodony vs. Village of Sands Point](#)

[-Sylvia Pentel vs. City of Mendota Heights](#)

[-Appeal of Lord \(Supreme Court of Pennsylvania, 1951\)](#)

-Stay tuned! More to come, as soon as I can type it in!

Good Tower/Antenna Sites on the Web

(I am constantly on the lookout for more. Know of one? Email the URL to me!)

[-Frank, VE3FLF's, web site](#) Solid info and great photos!

[-Don Stoner's Restrictive Antenna Covenants Home Page](#)



[SEND ME E-MAIL](#)

WWW.SWL.NET



FREE WEB PAGES FOR
SHORTWAVE LISTENERS



-this page first posted Sunday, April 5, 1998 (more to come)

Call Search

[\[Articles Home\]](#) [\[Add Article\]](#)

CC&R Survival Series

[Bill Fisher \(W4AN\)](#) on January 8, 2001

[View comments about this article!](#)

I would like to propose the start of a series of articles from people who are still able to be active hams while living within restrictive covenants. I happen to be one of those people, and I am on the air daily on several bands with good signal reports and long QSOs. I am currently writing an article on an antenna that I am building and hope to have it posted in a week or two.

If you are successfully operating the radio under restrictive covenants and have advice or interesting success stories, please take a few minutes to pass them on the rest of us. If you know someone else who is surviving CC&R's, please drop me a line with their email address and I will contact them about writing an article for us.

73

Bill Fisher, W4AN w4an@contesting.com

Member Comments: [Add A Comment](#)

CC&R Survival Series

by [AD6LR](#) on January 8, 2001

[Reply](#)

[Mail this to a friend!](#)

Email Subscription

You are not subscribed to discussions on this article.

[Subscribe!](#)

[My Subscriptions](#)

[Subscriptions Help](#)

Other Editorial Articles

- [Truck Drivers Taking Over Lower Portion of 10-Meters](#)
- [Are We Hurting Ham Radio?](#)
- [How Stupid Do They Think We Are?](#)
- [Help Needed in Going Back!](#)
- [Moving On Up](#)



[Dayton 2004 Photos](#)

[New to Ham Radio?](#)

My eHam

[Profile](#)

[Email Subscriptions](#)

Community

[Articles](#)

[Forums](#)

[Friends Remembered](#)

[Speak Out](#)

[Strays](#)

[Survey Question](#)

Operating

[Contesting](#)

[DX Cluster Spots](#)

[Propagation](#)

Resources

[Calendar](#)

[Callbook](#)

[Classifieds](#)

[Ham Exams](#)

[Ham Links](#)

GigaParts
Online Superstore



**LOW
Price
Guarantee!**

List Archives
 News Articles
 Product Reviews
 QSL Managers
 Discount Books

Site Info

About eHam.net
 Support the site
 eHam Help (FAQ)
 Vision Statement
 eHam Team
 Help Wanted
 Advertising Info

Sweepstakes



QSL Managers

Ham Links

Interesting topic. One item to include with CCR solutions would be how RF exposure issues are resolved; for example, it would be very difficult to have an antenna radiating 1.5 KW (say in the 10 meter band) located in the attic with an operator located close by and still meet the FCC RF exposure requirements.

AD6LR

CC&R Survival Series

[Reply](#)

Anonymous post on January 8, 2001

[Mail this to a friend!](#)

I live in a college dorm apt complex, with blanket antenna restrictions. I have (so far) gotten away with a run of magnet wire from my 2nd floor window to some trees about 50 feet away for SWL work, and I put a 2M groundplane on top of a homebrew T shaped PVC assembly with some pipe hangers and hung it off the gutter outside my window. The restrictions in our housing contract are written so broadly, that they could technically ban cordless phones, cell phones, stereos, clock radios, TVs, walkmans, etc.. (of course this was not the intent I'm sure).

RE: CC&R Survival Series

[Reply](#)

by [W4AN](#) on January 8, 2001

[Mail this to a friend!](#)

BTW, I was hoping we could have some articles from you survivors and not just comments posted to this article.

When I was in college, I snuck a piece of coax out the dorm room window up on to the roof. Luckily I was on the top floor. I put up a 40 meter dipole antenna off of the TV antenna mast. Antenna was probably a good 100' off the ground and worked VERY well.

Of course, my buddies with the stereo gear didn't appreciate it. But they were none the wiser of my being a ham. :)

73

RE: CC&R Survival Series[Reply](#)by [K1IR](#) on January 9, 2001[Mail this to a friend!](#)

A distinction that would be interesting to understand in each situation is whether the operation is OVERT or COVERT. Is your setup known to management and approved, known to management but not approved, or unknown to management? By separating situations into these categories, a variety of interesting strategies can be devised.

I only operated 2fm from my dorm room in college - and my mag-mount 1/4-wave vertical was confiscated more than once. It was an engineering school. We had a nuclear power lab on campus. We had biotech engineers cloning each other. Didn't management have anything better to worry about than my 2m whip? Good thing we had a great ham station and I was eventually the Station Manager.

73,

Jim

CC&R Survival Series[Reply](#)by [K3AN](#) on January 9, 2001[Mail this to a friend!](#)

I chose, and my wife accepted, a home with trees and undeveloped space close behind the house. If you have such "natural antenna supports" on your property, it makes getting on the air in stealth mode much easier.

The end-fed antenna is 130' of #26 black insulated wire in the trees, worked against a single ground rod. The system is matched using the great SGC-230 remote antenna tuner. By using a wire that's a multiple of a half wave at 80, 40, 20, 15 and 10, the feedpoint impedance is relatively high so ground losses from using just the single ground rod are relatively low.

The SGC is fastened to the "back side" of a tree trunk just above ground level, and disguised by setting some broken limbs alongside it to break up its outline. The coax and 12 volt power cables are buried in a shallow trench to the point where they are routed up a deck support post and into the basement

through the sill plate. I laid out and buried the cables one evening when I knew the nearest neighbor was away.

The antenna wire is very difficult to see against the trees, even when you're looking for it. At a previous, rented QTH, I ran this kind of wire from the second story of my townhouse across the parking lot and into a tree. None of the neighbors ever noticed it until one neighbor had a visitor who was a ham. The ham pointed it out, but since my QRP operation hadn't been causing any QRM, the neighbor didn't raise any kind of fuss.

A slingshot with a 1 oz lead sinker can fire 10 lb test line a remarkable distance up and out. I use a fluorescent green line to make finding the far end easier. Cut off the sinker, tie the antenna wire to the line, reel it in from your launch point, and you're well on your way to stealth hamming.

CC&R Survival Series[Reply](#)

by [WA6KGI](#) on January 9, 2001

[Mail this to a friend!](#)

Hello Bill,

Sure I will comment. I am currently buying a house in Texas. It has a deed restriction and I think I can beat it. At least I am going to try because the Homeowner's association does not charge any dues. The restriction is poorly worded too. I am going to first speak with attorney buddies to see what I can do about having it removed from the deed (when I get that as I have not yet seen it.) The land size is nice, about an acre and well treed. I think I can easily hide wires in the trees. A tower is the big question.

I will keep you informed.

73 de WA6KGI

Jack

CC&R Survival Series[Reply](#)

by [KA4JNB](#) on January 10, 2001

[Mail this to a friend!](#)

We had our house built in a very restrictive neighborhood. I particularly hate the restriction against growing a vegetable garden. However, the covenant against antennas is vague, reading "no unsightly structures" which eliminates towers of course.

I planned ahead. I selected a lot with dense woods extending over 300' behind the house. Then I borrowed a plane-table, a fairly simple surveying device, and mapped all the significant trees growing there. With this done, I selected trees to support my dipoles, out of sight, and was lucky enough to have a large maple tree, 150 feet back in the forest, with the main trunk forming an arch at about forty-five degrees. Throwing a line over this "limb" and clearing all growth underneath, I pulled a full wave two-element Lighting brand quad wired for five bands up off the ground eight feet. I then poured a 24X24 inch pad with a pipe flange secured to its surface with spikes, screwed a 3 foot galvanized pipe into it, mounted a CDE rotor on the pipe, and used a telescoping Radio Shack mast to connect to the boom. The limb holds the weight and the rotor works great. I painted the poly arms green and brown, and you really have to make an effort to see the setup. (we are in the lowest elevation on the subdivision, and I still compete successfully in the pileups, 5BDXCC, 5BWAS, etc. Not as easy as with a tower at a higher elevation of course, but I still enjoy good DXing)

CC&R Survival Series

by [WA4CNG](#) on January 10, 2001

[Reply](#)

[Mail this to a friend!](#)

I am still surviving after making Y2K-DXCC in October last year with my Attic Antennas (Article posted here). You and I live less than 15 miles apart in Alpharetta Ga. I have made some changes up there, got rid of the Square Loops, added a 6 meter dipole. Hamshack and shop is now in the Terrace Level, added an Amertron AI-811H amplifier, feeding the antennas with 1/2 inch hardline in the attic via the conduit I had installed by the builder. I am still working on getting 75 meters to work. I am having mixed results, mostly not, from the DX-SA Antenna I

installed for 75/20 meters. VHF/UHF is great with the ground elevation of 1140FT, plus 35 feet into the attic. That is nearly 1200 Feet ASL in Atlanta Ga, where the average terrain is 1000 feet, like having a 200 ft tower in the backyard.

CC&R Survival Series[Reply](#)

Anonymous post on January 10, 2001

[Mail this to a friend!](#)

My subdivision bans antennas. I am taking a two prong tact: First, I volunteered for the architectural review board and wound up as chairman. This gives me a lot of "inside influence" especially when convincing others that new PRB-1 actually applies to ham antennas in CC&Rs. Second, I applied a loophole that allows "satellite antennas" (intended for tv of-course) and called my 6 meter rotatable dipole a "satellite antenna" who knows, it might pick up a satellite signal! Since we have some trees, I can keep things low profile until I get bolder...so I put up a MARTIN HOUSE (you know - for Purple Martins) on a 15 foot steel pole. I have a radial system below it on the ground. I dont feed the pole, I have thin black wires attached at the top and coming down to feed point at the bottom (I use a remote switch to change antennas) these form inverted Ls on 160-10 meters. I had to bend the 160 L (more of a W than L)around my small yard a lot. I can run up to 700 watts...never a complaint from neighbors. I work the world on 100 watts including a lot of dx on 160. This stealth stuff is almost as much fun as working dx from a tower/beam...like the WWII resistance/spy novels I liked as a kid.

I'll let you know if I can get more overt.

I,m anonymous because of my insider position!

CC&R Survival Series[Reply](#)

by [KOMU](#) on January 13, 2001

[Mail this to a friend!](#)

The previous poster mentioned that satellite antennas are allowed. Any HF antenna that covers 10 and 15 meters is a "satellite antenna." RS12 has uplink on 15 and downlink on 10. Therefore any HF antenna / beam should be allowed. The satellite industry did us a favor!!! Is this a loophole?

CC&R Survival Series[Reply](#)

by [KD5LJH](#) on January 15, 2001

[Mail this to a friend!](#)

I appreciate all the posts about the CC&R's..... When i first started reading about it back in like sept-octish, I thought oh whats the big deall..... you know... then I started checking into it more and started understanding why its a big topic. Well, I'm finally getting my first apartment next month, and I'm pretty sure I'm not going to be able to erect anything like an antenna on top of the building for my radio working fun. So, basically I just want to thank you all that have posted on this and it has helped me with ideas and ways to get around this problem. Thanks once again guys.

73's,

Jonathan
KD5LJH

CC&R Survival Series[Reply](#)

Anonymous post on January 16, 2001

[Mail this to a friend!](#)

Maybe I'm nuts, but if I saw a development that actually had a CC&R against a VEGETABLE GARDEN, I'd go look somewhere else. Antennas or no antennas.

CC&R Survival Series[Reply](#)

by [W6WO](#) on January 16, 2001

[Mail this to a friend!](#)

It is most important to be on good terms with the HOA Board, join it if you can. I obtained approval by writing a letter to the Board explaining the benefits from emergency communications that I can provide the community in times of emergency. I mentioned in my letter that one such antenna could be treated as a special case in any community without creating a precedent for others. I compared the profile of my R6000 vertical in sq ft to a DBS dish. I stated that I would assist any homeowner who encountered problems but stopped short of saying that I would fix any problem.

They asked questions about RF health and I responded by saying my power was controlled by my FCC licence and is about the same as a lightbulb. They also asked questions about the installation and I explained my method of attachment to the apex of my roof and could quote the EIA requirements for grounding.

RE: CC&R Survival Series

[Reply](#)

by [KC0EAO](#) on January 16, 2001

[Mail this to a friend!](#)

Jonathan (KD5LJH):

I'm an apartment dweller and have lived in several apartments. I think the most important thing you can do is *ask your landlord* about antennas *before* you put them up. If you explain the purpose of the antennas and amateur communication, the proposed installation procedure, and the safety measures in place regarding the antennas you might be surprised how willing they are to work with you. I have an A99 (17' tall) and a Diamond X50A (6' tall, on a 15' mast) both mounted on my balcony and the landlord doesn't have a problem with them because I asked first and did not damage the apartment installing them. 73

Dan

RE: CC&R Survival Series

[Reply](#)

by [AE7G](#) on January 16, 2001

[Mail this to a friend!](#)

At one time, I had a wife who was adamant about NO ugly towers, and No ugly antennas on the house. Our house was on 1 acre with many trees in the back, where the majority of land was. One day while she was away, I put up a 1/4 wave GP for 40 meters made out of brown wire and a SO239 (I didn't know then that a delta loop would have been better. I used a pine tree to pull the fishing line up to hold the vertical wire, and fishing line to tie the radials to other trees. The radials were 6 feet off the ground, along with the feed point. The vertical portion wasn't totally vertical, it sloped from the feed point that was about 5 feet away from the pine tree. About 18 months later, we were on the back porch watching a sunset through and over the trees in the back, and my wife wondered what that shiny thing was hanging in the air about 30 feet away from the house (my SO239) I had tons of fun with that antenna and a SB220 amplifier. And, yes, the antenna stayed up, after the shiny "free floating" thing was observed. You had to look very carefully in the winter time when there weren't leaves on the trees to find the antenna.

I remember one time when I was single and in a crowded housing development, my neighbor asked me why I had a brick and an arrow hanging from a tree in my front yard (He didn't see the brown vertical wire from the top of the tree to the ground). The arrow and brick got caught in the tree when they were thrown or shot over the tree and the fishing line got caught in the tree. I explained I had used them, and they got caught in the tree, to pull a thin wire in the tree to use for my nightly SWL.

CC&R Survival Series[Reply](#)

by [AB7RG](#) on January 17,
2001

[Mail this to a friend!](#)

Hmm... Looks like I'll have to start on the one I was working on doing back in early October of last year after I arrived out here in Chicago. I've had to be pretty creative, but so far things are working very well. I will however be very happy to return to sunny & warm Arizona where I have much less restrictions, actually there are some where I currently live out there, but I did get around them... :^)

Anyway Bill look for an article submission by me in a few weeks. I've been so busy with computer consulting and my business on the 'net that I haven't had time to do any free-lance writing (for anyone), in the past four months. I think that I still have the framework for that article on my HD and a few of the pictures that I took of a couple of my antenna setups as well. It's not much, but it works. I'm betting that we can really learn from one another on this subject...

"Where there's a ham there's a way!" 73 Clinton
AB7RG/9

RE: CC&R Survival Series

Anonymous post on January 17,
2001

[Reply](#)

[Mail this to a
friend!](#)

I am in a college dorm at an engineering school. Due to the fact that my dorm has a "grounded" chicken wire network in all the walls under the plaster and I cannot remove the screen at all, there is little hope of a signal getting out. I use a twin-lead J-pole (I know it isn't the best, but no where to put a mag mount) in the window frame itself. I am able to get into the close, local repeaters and on packet (2m FM) without too much trouble, but since I am chief op at the local Ham Club, I can use that equipment if necessary with all the outdoor antennas. All in all, I live in a pandora's box that eats signals and am just lucky that I can get anything out at all. The neighbors don't like the intermod through the computer speakers though, hihi. If I was able to remove the screen and get an antenna out into the tree outside of my antenna, I would have get better signal reports and my pbbs wouldn't time everyone out.

CC&R Survival Series[Reply](#)by [W6OPO](#) on January 20, 2001[Mail this to a friend!](#)

I bought my house about 6 years ago in a now 20 year old neighborhood (San Jose CA). CC&R's are clear and legal. No antennas, no basketball hoops no, can't work on cars in driveway, keep garage doors closed.... Then there is reality.

When I was considering the the house I plotted. Seeing the conditions in the neighborhood I could see the CC&R's were not being enforced, no gross violations but RVs are here etc.

My house is next to the end of culdesac and backs on to a freeway. That means no backyard neighbors. With a streetlight on my curb first up was a 133' dipole from the streetlight to the backyard. Used phylstrand and no insulator on the street end. It is almost invisible. That was good for 40 & 80 now what about a beam?

I bought a 40' tubular tower (used) with the rotor at the base. That with a Force12 C3-S (12' boom no traps no rotor at the top) made for the lowest profile cleanest installation one could think of. The tower went up about 2 years after the dipole and been up exactly a year and the folks are peaceful.

Bob

CC&R Survival Series[Reply](#)by [K7LA](#) on January 21, 2001[Mail this to a friend!](#)

Our current QTH does not have CC&R's which was a major factor in our decision to purchase the property. Our previous residence was a gated community with strict CC&R's and an overly-nosey property management firm. One easy way to beat restrictions is to operate MOBILE from your vehicle. I used to sit out in the driveway operating HF with a screwdriver-type antenna while the jerk manager just stood there raising his blood pressure. It's a great feeling knowing there's nothing they can do about it.

CC&R Survival Series[Reply](#)by [N9PSR](#) on February 3,
2001[Mail this to a friend!](#)

Hello,

My family and I live in graduate and family housing at Western Illinois University (WIU) and any outside antennas are strictly prohibited. So I go to my wife's minivan and operate mobile (stationary). For some silly reason the state of Illinois is very reluctant to grant a driver's license to a legally blind individual. hi hi. I usually run 100 watts from my Icom 706MkII through a hustler mobile antenna. So far I've worked 7 foreign countries and about half of the states on 40m. Since Sequoia my Leader Dog is usually with me I can get away with saying "we" while operating. hi hi. although for the most part I try to avoid using hambabble on the air. One of these days I'll get up to courage to "run with the big dogs" and operate CW. A friend from my former hometown loaned me a non J-38 antique straight key- it had been used in World War two by the Army. Some of the reasons I like working mobile (stationary) are:

- 1.) My five year old daughter isn't being exposed to RF.
- 2.) My wife can't complain about wires being run all over the apartment.
- 3.) Fellow hams seem to be more willing to talk to a "Mobile" station... hi hi hi

73

de

Wayne M. Scace & Leader Dog Sequoia

n9psr@arrl.net

FISTS#4409

CC&R Survival Series[Reply](#)by [N5UOA](#) on November 16,
2001[Mail this to a friend!](#)

Her is one for the books as to Deeds and restrictions here where I live, Maybe we can get something done as to this fracture I have found.

IN my meighborhood there are SIX(6) differant deed systems which ALL but ONE doesnt allow antennas.

I live at the end of the street,4th house form the corner NOW the side streets, and house's behind me behind my back yard can HAVE antennas but no higher than 10 feet above the roofline. HOWEVER my street for a quarter of a block is in the DEEDED company that doesnt allow for any antennas.

When I first moved in The antenna could be spotted and got a notice to take it down which I did, and then put up another one that couldnt be seen from the front of the house.

SO FAR in 10 yrs I have not gotten a notice, to take it down. I have a six element antenna and going to get a smaller one 3 element, beam. I have been lucky im a disabled person and this is what I do to stay active as a Disabled Veteran is be a ham and help during flods and disasters. About 2 yrs ago on all the houses here on my block I have spotted satelitte antennas, and everyone I have talked to said they could put them up, SO I DONT KNOW if this blows out the ALL NO ANTENNA DEED RESTRICTION-- since they have let in one type of antenna. ALSO to my DISBELIEF is everyone has BEEN HIJACKED as to TV here, due to not being able to put up a tv antenna, we have to have cable tv installed, which to me takes away my rights to Television and putting up a antenna, WISH we could get these B*****S as to HIJACKING rights.

IT is a shame that in all the areas around me people have antennas outside and this one small quarter of a blovk who is under HOUSING PROPERTY MANAGENT wont let any antennas be had and everyone else does.

LOVE DISCRIMINATION here as to what I have to live with. About a year ago I wrote a long letter to the ARRL< about how this is here to see if in the future the FCC who has NO BACKBONE anymore full of

POLITICINS turn their backs on the very HAMS who might be the only communications due to terrorism today in the US.

Thanks for reading

Mark N5UOA

CC&R Survival Series[Reply](#)

by [N0VJC](#) on February 24, 2004

[Mail this to a friend!](#)

I decided to follow the rules and apply for the antennas through normal channels. I was turned down at first and went before the board to state my case. After some muscle flexing by the board and some ego stroking by me, they approved the installation of my Hustler 4-BTV. I also use a Webster Bandspanner mounted on the ground, but this one is short enough that it doesn't fall under the rules. For two meters, I have an Isopole 144 mounted to the back of the chimney. Since it is not visible for anyplace but my backyard, it is not a problem either.

In my case, an unexpected ally turned out to be the manager of the Management Company. She explained to the board that during times of disaster, having a ham in the neighborhood is invaluable. I cannot wait for some legislation to assist hams with their antenna issues, but in the interim, I would advise hams to at least try to follow the rules and be reasonable in their request. I have no doubt that they would have turned me down completely if I had asked for "forgiveness" instead of "permission". I want to mention though, that I was going to use my 4-BTV even if I had been turned down. A wing nut at the bottom would have made it easy to remove from the ground mount, so that I could have taken it down when I wasn't using it. A pain in the neck, but better than nothing and not against the rules. Unfortunately not everyone's antennas lend themselves to this type of solution.

73,

-Steve Weidman N0VJC

CC&R Survival Series[Reply](#)

by [N2CTZ](#) on April 13, 2004

[Mail this to a friend!](#)

how about we just refuse to buy houses where there are c&r and hoa-i just found an older house on one acre no c&rs no hoa i can have antennae ,poultry and horses!

tell all your friends not to buy houses with c&rs!

RE: CC&R Survival Series [Reply](#)
by [KC4UAI](#) on August 4, 2004 [Mail this to a friend!](#)

Not Buying a house with CCNR's is becoming more and more difficult. Most newer homes will have CCNRs, and the remaining older homes are either too expensive, or are in undesirable locations.

I checked in my local area and found that about 90% of the houses that I could afford had CCNRs. I suspect that this percentage would be less in a more rural area, but one has to live where they can earn a living.

I was wondering... Has anybody conducted a formal study to determine the % of houses that have CCNRs, versus the % that don't. Would not the same argument that the FCC used to justify state and local preemption, be valid for CCNR's if the percentage of homes available was very small?

I would suspect that the % of available houses w/o CCNRs has been drastically reduced since the PRB-1 rules were put into effect, and I sometimes wonder if the FCC would listen to that argument. I suppose it's wishful thinking, so we can hope that the CCNR bill makes it through congress..

73's

-= KC4UAI =-

Copyright 2000-2004 eHam.net, LLC
eHam.net is a community web site for amateur (ham) radio operators around the world.
Contact webmaster1@eHam.Net with comments or questions.

[Site Privacy Statement](#)

This web site is hosted &
created by AkornHosting.com



Enjoy world-class music by an active ham!

[click here](#)

[eHam.net Home](#) | [FAQ](#) | [Log In Help!](#) | [Please Subscribe!](#) [Welcome Anonymous](#) [Become a member!](#) or [Login!](#)

Call Search

[eHam.net Forum](#) | [AntennaRestrictions](#) | [List of Topics](#) [Forum Help](#)

[Create a New Topic in AntennaRestrictions](#)

You are currently viewing the most recently created topics in the AntennaRestrictions forum.

Page 1 of 14

262 AntennaRestrictions Topics.

[Next](#)

| Topics | Originator | Posts | Last Reply |
|--|--------------------------|-------|------------|
| Question about Versatuner II | KG6VQE | 5 | 09/6/04 |
| Random Wire around Eve's of House | KG6VQE | 3 | 09/6/04 |
| Stealth 20Meter 1/2 Wave Vertical | KG6VQE | 3 | 09/2/04 |
| Best LDG antenna tuner for ButterNut HF6V vertical | VE7ALQ | 13 | 08/29/04 |
| Tower Height Restrictions for Dauphin Island, AL | JOHNNY_O | 4 | 08/24/04 |
| Need legal citations of successful court cases | W0AVV | 1 | 08/5/04 |
| CC + R's | N0RKX | 22 | 08/13/04 |
| Restrictions: Who to ask? | W4XKE | 9 | 07/22/04 |
| the right mobile antenna | SDMF69 | 3 | 07/14/04 |
| vertical in a tree | ORTHOS1 | 8 | 08/28/04 |
| HF Vertical for antenna restriction | IK8WTD | 1 | 06/30/04 |
| Hy-gain Doublet Dipole | WB6DFW | 2 | 08/9/04 |

Search AntennaRestrictions:

Hottest Topics

- [Best LDG antenna tuner for ButterNut HF6V vertical](#)
- [Question about Versatuner II](#)
- [Stealth 20Meter 1/2 Wave Vertical](#)
- [Random Wire around Eve's of House](#)
- [Tower Height Restrictions for Dauphin Island, AL](#)
- [vertical in a tree](#)
- [Long wire on roof](#)

Recently Active Topics

- [PRB-1](#)
- [advise needed, where to procede?](#)
- [vertical VB 800](#)
- [Apartment - how to Mount feedline](#)
- [Where there's a will...](#)
- [Did you try EH antennas?](#)



[Dayton 2004 Photos](#)

[New to Ham Radio?](#)

My eHam

- [Profile](#)
- [Email Subscriptions](#)

Community

- [Articles](#)
- [Forums](#)
- [Friends Remembered](#)
- [Speak Out](#)
- [Strays](#)
- [Survey Question](#)

Operating

- [Contesting](#)
- [DX Cluster Spots](#)
- [Propagation](#)

Resources

- [Calendar](#)
- [Callbook](#)
- [Classifieds](#)
- [Ham Exams](#)
- [Ham Links](#)

- List Archives
- News Articles
- Product Reviews
- QSL Managers
- Discount Books

Site Info

- About eHam.net
- Support the site
- eHam Help (FAQ)
- Vision Statement
- eHam Team
- Help Wanted
- Advertising Info

Sweepstakes



QSL Managers

Ham Links

| | | | |
|--|--------------------------|---|----------|
| 2nd floor apartment HF antenna help! | N5ZGT | 5 | 08/22/04 |
| Join Ham Radio World (A free MSN group) | GEOVHILL | 4 | 07/4/04 |
| How many States have uniform Antenna / Tower laws? | W0AVV-1 | 8 | 07/9/04 |
| Yagi indoors | RBOUVIA | 9 | 06/6/04 |
| Apt Antenna Advice | KG4PQA | 4 | 06/1/04 |
| baby boomer quad | ON7ZZ | 2 | 06/30/04 |
| A G5RV (Dipole) Antenna Question Regarding A Tree | KA3NRX | 5 | 05/23/04 |
| Maybe a different Stealth wire idea | KD7SPQ | 4 | 05/17/04 |

- [The other side of the fence...](#)
- [wire and MFJ-934](#)
- [Soffit antenna](#)
- [LITTLE TARHEEL ANT](#)

Check our [help page](#) for help using Forum, or send questions, comments, or suggestions to the [Forum Manager](#).

[Manage My Subscriptions](#)



Copyright 2000-2004 eHam.net, LLC
 eHam.net is a community web site for amateur (ham) radio operators around the world.
 Contact webmaster1@eHam.Net with comments or questions.

[Site Privacy Statement](#)

This web site is hosted & created by [AkornHosting.com](#)

FEDERAL COMMUNICATIONS COMMISSION



FACT SHEET

May 2001

Over-the-Air Reception Devices Rule

Preemption of Restrictions on Placement of Direct Broadcast Satellite, Multichannel Multipoint Distribution Service, and Television Broadcast Antennas

Quick Links to Document Sections Below

- [Questions and Answers](#)
- [Links to Relevant Orders and the Rule](#)
- [Guidance on Filing a Petition](#)
- [Where to Call for More Information](#)

As directed by Congress in Section 207 of the Telecommunications Act of 1996, the Federal Communications Commission adopted the Over-the-Air Reception Devices Rule concerning governmental and nongovernmental restrictions on viewers' ability to receive video programming signals from direct broadcast satellites ("DBS"), multichannel multipoint distribution (wireless cable) providers ("MMDS"), and television broadcast stations ("TVBS").

The rule is cited as 47 C.F.R. Section 1.4000 and has been in effect since October 14, 1996. It prohibits restrictions that impair the installation, maintenance or use of antennas used to receive video programming. The rule applies to video antennas including direct-to-home satellite dishes that are less than one meter (39.37") in diameter (or of any size in Alaska), TV antennas, and wireless cable antennas. The rule prohibits most restrictions that: (1) unreasonably delay or prevent installation, maintenance or use; (2) unreasonably increase the cost of installation, maintenance or use; or (3) preclude reception of an acceptable quality signal.

Effective January 22, 1999, the Commission amended the rule so that it also applies to rental property where the renter has an exclusive use area, such as a balcony or patio.

On October 25, 2000, the Commission further amended the rule so that it applies to customer-end antennas that receive and transmit fixed wireless signals. This amendment became effective on May 25,

2001.

The rule applies to viewers who place antennas that meet size limitations on property that they own or rent and that is within their exclusive use or control, including condominium owners and cooperative owners, and tenants who have an area where they have exclusive use, such as a balcony or patio, in which to install the antenna. The rule applies to townhomes and manufactured homes, as well as to single family homes.

The rule allows local governments, community associations and landlords to enforce restrictions that do not impair the installation, maintenance or use of the types of antennas described above, as well as restrictions needed for safety or historic preservation. In addition, under some circumstances, the availability of a central or common antenna can be used by a community association or landlord to restrict the installation of individual antennas. In addition, the rule does not apply to common areas that are owned by a landlord, a community association, or jointly by condominium or cooperative owners. Such common areas may include the roof or exterior wall of a multiple dwelling unit. Therefore, restrictions on antennas installed in or on such common areas are enforceable.

This fact sheet provides general answers to questions that may arise about the implementation of the rule, but is not the rule itself. For further information or a copy of the rule, call the Federal Communications Commission at 888-CALLFCC (toll free) or (202) 418-7096. The rule is also available via the Internet by going to [links to relevant Orders and the rule](#).

Q: What types of antennas are covered by the rule?

A: The rule applies to the following types of video antennas:

- (1) A "dish" antenna that is one meter (39.37") or less in diameter (or any size dish if located in Alaska) and is designed to receive direct broadcast satellite service, including direct-to-home satellite service, or to receive or transmit fixed wireless signals via satellite.
- (2) An antenna that is one meter or less in diameter or diagonal measurement and is designed to receive video programming services via MMDS (wireless cable) or to receive or transmit fixed wireless signals other than via satellite.
- (3) An antenna that is designed to receive local television broadcast signals. Masts higher than 12 feet above the roofline may be subject to local permitting requirements.

In addition, antennas covered by the rule may be mounted on "masts" to reach the height needed to receive or transmit an acceptable quality signal (e.g. maintain line-of-sight contact with the transmitter or view the satellite). Masts higher than 12 feet above the roofline may be subject to local permitting requirements for safety purposes. Further, masts that extend beyond an exclusive use area may not be covered by this rule.

Q: What are "fixed wireless signals"?

A: "Fixed wireless signals" are any commercial non-broadcast communications signals transmitted via wireless technology to and/or from a fixed customer location. Examples include wireless signals used to provide telephone service or high-speed Internet access to a fixed location. This definition does **not** include, among other things, AM/FM radio, amateur ("HAM") radio, Citizens Band ("CB") radio, and Digital Audio Radio Services ("DARS") signals.

Q: Does the rule apply to hub or relay antennas?

A: The rule applies to "customer-end antennas" which are antennas placed at a customer location for the purpose of providing service to customers at that location. The rule does not cover antennas used to transmit signals to and/or receive signals from multiple customer locations.

Q: What types of restrictions are prohibited?

A: The rule prohibits restrictions that impair a person's ability to install, maintain, or use an antenna covered by the rule. The rule applies to state or local laws or regulations, including zoning, land-use or building regulations, private covenants, homeowners' association rules, condominium or cooperative association restrictions, lease restrictions, or similar restrictions on property within the exclusive use or control of the antenna user where the user has an ownership or leasehold interest in the property. A restriction impairs if it: (1) unreasonably delays or prevents use of; (2) unreasonably increases the cost of; or (3) precludes a person from receiving or transmitting an acceptable quality signal from an antenna covered under the rule. The rule does not prohibit legitimate safety restrictions or restrictions designed to preserve designated or eligible historic or prehistoric properties, provided the restriction is no more burdensome than necessary to accomplish the safety or preservation purpose.

Q: What types of restrictions unreasonably delay or prevent viewers from using an antenna?

A: A local restriction that prohibits all antennas would prevent viewers from receiving signals, and is prohibited by the Commission's rule. Procedural requirements can also unreasonably delay installation, maintenance or use of an antenna covered by this rule. For example, local regulations that require a person to obtain a permit or approval prior to installation create unreasonable delay and are generally prohibited. Permits or prior approval necessary to serve a legitimate safety or historic preservation purpose may be permissible.

Q: What is an unreasonable expense?

A: Any requirement to pay a fee to the local authority for a permit to be allowed to install an antenna would be unreasonable because such permits are generally prohibited. It may also be unreasonable for a local government, community association or landlord to require a viewer to incur additional costs

associated with installation. Things to consider in determining the reasonableness of any costs imposed include: (1) the cost of the equipment and services, and (2) whether there are similar requirements for comparable objects, such as air conditioning units or trash receptacles. For example, restrictions cannot require that expensive landscaping screen relatively unobtrusive DBS antennas. A requirement to paint an antenna so that it blends into the background against which it is mounted would likely be acceptable, provided it will not interfere with reception or impose unreasonable costs.

Q: What restrictions prevent a viewer from receiving an acceptable quality signal?

A: For antennas designed to receive analog signals, such as TVBS, a requirement that an antenna be located where reception would be impossible or substantially degraded is prohibited by the rule. However, a regulation requiring that antennas be placed where they are not visible from the street would be permissible if this placement does not prevent reception of an acceptable quality signal or impose unreasonable expense or delay. For example, if installing an antenna in the rear of the house costs significantly more than installation on the side of the house, then such a requirement would be prohibited. If, however, installation in the rear of the house does not impose unreasonable expense or delay or preclude reception of an acceptable quality signal, then the restriction is permissible and the viewer must comply.

The acceptable quality signal standard is different for devices designed to receive digital signals, such as DBS antennas, digital MMDS antennas, digital television ("DTV") antennas, and digital fixed wireless antennas. For a digital antenna to receive or transmit an acceptable quality signal, the antenna must be installed where it has an unobstructed, direct view of the satellite or other device from which signals are received or to which signals are to be transmitted. Unlike analog antennas, digital antennas, even in the presence of sufficient over-the-air signal strength, will at times provide no picture or sound unless they are placed and oriented properly.

Q: Are all restrictions prohibited?

A: No, many restrictions are permitted. Clearly-defined, legitimate safety restrictions are permitted even if they impair installation, maintenance or use provided they are necessary to protect public safety and are no more burdensome than necessary to ensure safety. Examples of valid safety restrictions include fire codes preventing people from installing antennas on fire escapes; restrictions requiring that a person not place an antenna within a certain distance from a power line; and installation requirements that describe the proper method to secure an antenna. The safety reason for the restriction must be written in the text, preamble or legislative history of the restriction, or in a document that is readily available to antenna users, so that a person wanting to install an antenna knows what restrictions apply. Safety restrictions cannot discriminate between objects that are comparable in size and weight and pose the same or a similar safety risk as the antenna that is being restricted.

Restrictions necessary for historic preservation may also be permitted even if they impair installation, maintenance or use of the antenna. To qualify for this exemption, the property may be any prehistoric or

historic district, site, building, structure or object included in, or eligible for inclusion on, the National Register of Historic Places. In addition, restrictions necessary for historic preservation must be no more burdensome than necessary to accomplish the historic preservation goal. They must also be imposed and enforced in a non-discriminatory manner, as compared to other modern structures that are comparable in size and weight and to which local regulation would normally apply.

Q: How does the rule apply to restrictions on radiofrequency (RF) exposure from antennas that have the capability to transmit signals?

A: All transmitters regulated by the Commission, including the customer-end fixed wireless antennas (either satellite or terrestrial) covered under the amended rule, are required to meet the applicable Commission guidelines regarding RF exposure limits. The limits established in the guidelines are designed to protect the public health with a large margin of safety. These limits have been endorsed by federal health and safety agencies, such as the Environmental Protection Agency and the Food and Drug Administration. The Commission requires that providers of fixed wireless service exercise reasonable care to protect users and the public from RF exposure in excess of the Commission's limits. In addition, as a condition of invoking protection under the rule from government, landlord, and association restrictions, a provider of fixed wireless service must ensure that customer-end antennas are labeled to give notice of potential RF safety hazards posed by these antennas.

It is recommended that antennas that both receive and transmit signals be installed by professional personnel to maximize effectiveness and minimize the possibility that the antenna will be placed in a location that is likely to expose subscribers or other persons to the transmit signal at close proximity and for an extended period of time. In general, associations, landlords, local governments and other restricting entities may not require professional installation for receive-only antennas, such as one-way DBS satellite dishes. However, local governments, associations, and property owners may require professional installation for **transmitting** antennas based on the safety exception to the rule. Such safety requirements must be: (1) clearly defined; (2) based on a legitimate safety objective (such as bona fide concerns about RF radiation) which is articulated in the restriction or readily available to antenna users; (3) applied in a non-discriminatory manner; and (4) no more burdensome than necessary to achieve the articulated objectives.

For additional information about the Commission's RF exposure limits, please visit <http://www.fcc.gov/oet/rfsafety> or call the RF Safety Information Line at 202-418-2464.

Q: Whose antenna restrictions are prohibited?

A: The rule applies to restrictions imposed by local governments, including zoning, land-use or building regulations; by homeowner, townhome, condominium or cooperative association rules, including deed restrictions, covenants, by-laws and similar restrictions; and by manufactured housing (mobile home) park owners and landlords, including lease restrictions. The rule only applies to restrictions on property where the viewer has an ownership or leasehold interest and exclusive use or control.

Q: If I live in a condominium or an apartment building, does this rule apply to me?

A: The rule applies to antenna users who live in a multiple dwelling unit building, such as a condominium or apartment building, if the antenna user has an exclusive use area in which to install the antenna. "Exclusive use" means an area of the property that only you, and persons you permit, may enter and use to the exclusion of other residents. For example, your condominium or apartment may include a balcony, terrace, deck or patio that only you can use, and the rule applies to these areas. The rule does not apply to common areas, such as the roof, the hallways, the walkways or the exterior walls of a condominium or apartment building. Restrictions on antennas installed in these common areas are not covered by the Commission's rule. For example, the rule would **not** apply to prohibit restrictions that prevent drilling through the exterior wall of a condominium or rental unit.

Q: Does the rule apply to condominiums or apartment buildings if the antenna is installed so that it hangs over or protrudes beyond the balcony railing or patio wall?

A: No. The rule does not prohibit restrictions on antennas installed beyond the balcony or patio of a condominium or apartment unit if such installation is in, on, or over a common area. An antenna that extends out beyond the balcony or patio is usually considered to be in a common area that is not within the scope of the rule. Therefore, the rule does not apply to a condominium or rental apartment unit unless the antenna is installed wholly within the exclusive use area, such as the balcony or patio.

Q: Does the fact that management or the association has the right to enter these areas mean that the resident does not have exclusive use?

A: No. The fact that the building management or the association may enter an area for the purpose of inspection and/or repair does not mean that the resident does not have exclusive use of that area. Likewise, if the landlord or association regulates other uses of the exclusive use area (e.g., banning grills on balconies), that does not affect the viewer's rights under the Commission's rule. This rule permits persons to install antennas on property over which the person has *either* exclusive use *or* exclusive control. Note, too, that nothing in this rule changes the landlord's or association's right to regulate use of exclusive use areas for other purposes. For example, if the lease prohibits antennas and flags on balconies, only the prohibition of antennas is eliminated by this rule; flags would still be prohibited.

Q: Does the rule apply to residents of rental property?

A: Yes. Effective January 22, 1999, renters may install antennas within their leasehold, which means inside the dwelling or on outdoor areas that are part of the tenant's leased space and which are under the exclusive use or control of the tenant. Typically, for apartments, these areas include balconies, balcony railings, and terraces. For rented single family homes or manufactured homes which sit on rented property, these areas include the home itself and patios, yards, gardens or other similar areas. If renters do not have access to these outside areas, the tenant may install the antenna inside the rental unit. Renters are not required to obtain the consent of the landlord prior to installing an antenna in these areas. The rule

does not apply to common areas, such as the roof or the exterior walls of an apartment building. Generally, balconies or patios that are shared with other people or are accessible from other units are not considered to be exclusive use areas.

Q: Are there restrictions that may be placed on residents of rental property?

A: Yes. A restriction necessary to prevent damage to leased property may be reasonable. For example, tenants could be prohibited from drilling holes through exterior walls or through the roof. However, a restriction designed to prevent ordinary wear and tear (*e.g.*, marks, scratches, and minor damage to carpets, walls and draperies) would likely not be reasonable provided the antenna is installed wholly within the antenna user's own exclusive use area.

In addition, rental property is subject to the same protection and exceptions to the rule as owned property. Thus, a landlord may impose other types of restrictions that do not impair installation, maintenance or use under the rule. The landlord may also impose restrictions necessary for safety or historic preservation.

Q: If I live in a condominium, cooperative, or other type of residence where certain areas have been designated as "common," do these rules apply to me?

A: The rules apply to residents of these types of buildings, but the rules do not permit you to install an antenna on a common area, such as a walkway, hallway, community garden, exterior wall or the roof. However, you may install the antenna wholly within a balcony, deck, patio, or other area where you have exclusive use.

Drilling through an exterior wall, *e.g.* to run the cable from the patio into the unit, is generally not within the protection of the rule because the exterior wall is generally a common element. You may wish to check with your retailer or installer for advice on how to install the antenna without drilling a hole. Alternatively, your landlord or association may grant permission for you to drill such a hole. The Commission's rules generally do not cover installations if you drill through a common element.

Q: If my association, building management, landlord, or property owner provides a central antenna, may I install an individual antenna?

A: Generally, the availability of a central antenna may allow the association, landlord, property owner, or other management entity to restrict the installation by individuals of antennas otherwise protected by the rule. Restrictions based on the availability of a central antenna will generally be permissible provided that: (1) the person receives the particular video programming or fixed wireless service that the person desires and could receive with an individual antenna covered under the rule (*e.g.*, the person would be entitled to receive service from a specific provider, not simply a provider selected by the association); (2) the signal quality of transmission to and from the person's home using the central antenna is as good as, or better than, than the quality the person could receive or transmit with an individual antenna covered by

the rule; (3) the costs associated with the use of the central antenna are not greater than the costs of installation, maintenance and use of an individual antenna covered under the rule; and (4) the requirement to use the central antenna instead of an individual antenna does not unreasonably delay the viewer's ability to receive video programming or fixed wireless services.

Q: May the association, landlord, building management or property owner restrict the installation of an individual antenna because a central antenna will be available in the future?

A: It is not the intent of the Commission to deter or unreasonably delay the installation of individual antennas because a central antenna may become available. However, persons could be required to remove individual antennas once a central antenna is available if the cost of removal is paid by the landlord or association and the user is reimbursed for the value of the antenna. Further, an individual who wants video programming or fixed wireless services other than what is available through the central antenna should not be unreasonably delayed in obtaining the desired programming or services either through modifications to the central antenna, installation of an additional central antenna, or by using an individual antenna.

Q: I live in a townhome community. Am I covered by the FCC rule?

A: Yes. If you own the whole townhouse, including the walls and the roof and the land under the building, then the rule applies just as it does for a single family home, and you may be able to put the antenna on the roof, the exterior wall, the backyard or any other place that is part of what you own. If the townhouse is a condominium, then the rule applies as it does for any other type of condominium, which means it applies only where you have an exclusive use area. If it is a condominium townhouse, you probably cannot use the roof, the chimney, or the exterior walls unless the condominium association gives you permission. You may want to check your ownership documents to determine what areas are owned by you or are reserved for your exclusive use.

Q: I live in a condominium with a balcony, but I cannot receive a signal from the satellite because my balcony faces north. Can I use the roof?

A: No. The roof of a condominium is generally a common area, not an area reserved for an individual's exclusive use. If the roof is a common area, you may not use it unless the condominium association gives you permission. The condominium is not obligated to provide a place for you to install an antenna if you do not have an exclusive use area.

Q: I live in a mobile home that I own but it is located in a park where I rent the lot. Am I covered by the FCC rule?

A: Yes. The rule applies if you install the antenna anywhere on the mobile or manufactured home that is owned by you. The rule also applies to antennas installed on the lot or pad that you rent, as well as to other areas that are under your exclusive use and control. However, the rule does not apply if you want to

install the antenna in a common area or other area outside of what you rent.

Q: I want a conventional "stick" antenna to receive a distant over-the air television signal. Does the rule apply to me?

A: No. The rule does not apply to television antennas used to receive a distant signal.

Q: I want to install an antenna for broadcast radio or amateur radio. Does the rule apply to me?

A: No. The rule does not apply to antennas used for AM/FM radio, amateur ("ham") radio, Citizen's Band ("CB") radio or Digital Audio Radio Services ("DARS").

Q: I want to install an antenna to access the Internet. Does the rule apply to me?

A: Yes. Antennas designed to receive and/or transmit data services, including Internet access, are included in the rule.

Q: Does this mean that I can install an antenna that will be used for voice and data services even though it does not provide video transmissions?

A: Yes. The most recent amendment expands the rule and permits you to install an antenna that will be used to transmit and/or receive voice and data services, except as noted above. The rule will also continue to cover antennas used to receive video programming.

Q: I have already installed an antenna that is used solely for the purpose of receiving video programming. Am I affected by this amendment?

A: Persons who have already installed, or who plan to install, an antenna designed to receive only video programming are not affected by this amendment. The purpose of the amendment is to permit persons to install antennas that may be used for voice and data services, as well as for video programming services. The rules concerning restrictions on the placement of video antennas will apply equally to antennas that are used for voice and data services.

Q: I'm a board member of a homeowners' association, and we want to revise our restrictions so that they will comply with the FCC rule. Do you have guidelines you can send me?

A: We do not have sample guidelines because every community is different. We can send you the rule and the relevant orders, which will give you general guidance. (See list of documents at the [end of this factsheet](#). Some communities have written restrictions that provide a prioritized list of placement preferences so that residents can see where the association wants them to install the antenna. The residents should comply with the placement preferences provided the preferred placement does not

impose unreasonable delay or expense or preclude reception of an acceptable quality signal.

Q: What restrictions are permitted if the antenna must be on a very tall mast to get a signal?

A: If you have an exclusive use area that is covered by the rule and need to put your antenna on a mast, the local government, community association or landlord may require you to apply for a permit for safety reasons if the mast extends more than 12 feet above the roofline. If you meet the safety requirements, the permit should be granted. Note that the Commission's rule only applies to antennas and masts installed wholly within the antenna user's exclusive use area. Masts that extend beyond the exclusive use area are outside the scope of the rule. For installations on single family homes, the "exclusive use area" generally would be anywhere on the home or lot and the mast height provision is usually most relevant in these situations. For example, if a homeowner needs to install an antenna on a mast that is more than 12 feet taller than the roof of the home, the homeowners' association or local zoning authority may require a permit to ensure the safety of such an installation, but may not prohibit the installation unless there is no way to install it safely. On the other hand, if the owner of a condominium in a building with multiple dwelling units needs to put the antenna on a mast that extends beyond the balcony boundaries, such installation would generally be outside the scope and protection of the rule, and the condominium association may impose any restrictions it wishes (including an outright prohibition) because the Commission rule does not apply in this situation.

Q: Does the rule apply to commercial property or only residential property?

A: Nothing in the rule excludes antennas installed on commercial property. The rule applies to property used for commercial purposes in the same way it applies to residential property.

Q: What can a local government, association, or consumer do if there is a dispute over whether a particular restriction is valid?

A: Restrictions that impair installation, maintenance or use of the antennas covered by the rule are preempted (unenforceable) unless they are no more burdensome than necessary for the articulated legitimate safety purpose or for preservation of a designated or eligible historic site or district. If a person believes a restriction is preempted, but the local government, community association, or landlord disagrees, either the person or the restricting entity may file a Petition for Declaratory Ruling with the FCC or a court of competent jurisdiction. We encourage parties to attempt to resolve disputes prior to filing a petition. Often calling the FCC for information about how the rule works and applies in a particular situation can help to resolve the dispute. If a local government, community association, or landlord acknowledges that its restriction impairs installation, maintenance, or use and is preempted under the rule but believes it can demonstrate "highly specialized or unusual" concerns, the restricting entity may apply to the Commission for a waiver of the rule.

Q: What is the procedure for filing a petition or requesting a waiver at the Commission?

A: There is no special form for a petition. You may simply describe the facts, including the specific restriction(s) that you wish to challenge. If possible, attach a copy of the restriction(s) and any relevant correspondence. If this is not possible, be sure to include the exact language of the restriction in question with the petition. General or hypothetical questions about the application or interpretation of the rule cannot be accepted as petitions.

Petitions for declaratory rulings and waivers must be served on all interested parties. For example, if a homeowners' association files a petition seeking a declaratory ruling that its restriction is not preempted and is seeking to enforce the restriction against a specific resident, service must be made on that specific resident. The homeowners' association will not be required to serve all other members of the association, but must provide reasonable, constructive notice of the proceeding to other residents whose interests foreseeably may be affected. This may be accomplished, for example, by placing notices in residents' mailboxes, by placing a notice on a community bulletin board, or by placing the notice in an association newsletter. If a local government seeks a declaratory ruling or a waiver from the Commission, the local government must take steps to afford reasonable, constructive notice to residents in its jurisdiction (*e.g.*, by placing a notice in a local newspaper of general circulation). Proof of constructive notice must be provided with a petition. In this regard, the petitioner should provide a copy of the notice and an explanation of where the notice was placed and how many people the notice reasonably might have reached.

Finally, if a person files a petition or lawsuit challenging a local government's ordinance, an association's restriction, or a landlord's lease, the person must serve the local government, association or landlord, as appropriate. You must include a "proof of service" with your petition. Generally, the "proof of service" is a statement indicating that on the same day that your petition was sent to the Commission, you provided a copy of your petition (and any attachments) to the person or entity that is seeking to enforce the antenna restriction. The proof of service should give the name and address of the parties served, the date served, and the method of service used (*e.g.*, regular mail, personal service, certified mail).

All allegations of fact contained in petitions and related pleadings before the Commission must be supported by an affidavit signed by one or more persons who have actual knowledge of such facts. You must send an original and two copies of the petition and all attachments to: Secretary, Federal Communications Commission, 445 12th Street, S.W., Washington, D.C. 20554, Attention: Media Bureau.

Q: Can I continue to use my antenna while the petition or waiver request is pending?

A: Yes, unless the restriction being challenged or for which a waiver is sought is necessary for reasons of safety or historic preservation. Otherwise, the restriction cannot be enforced while the petition is pending.

Q: Who is responsible for showing that a restriction is enforceable?

A: When a conflict arises about whether a restriction is valid, the local government, community association, property owner, or management entity that is trying to enforce the restriction has the burden of proving that the restriction is valid. This means that no matter who questions the validity of the restriction, the burden will always be on the entity seeking to enforce the restriction to prove that the restriction is permitted under the rule or that it qualifies for a waiver.

Q: Can I be fined and required to remove my antenna immediately if the Commission determines that a restriction is valid?

A: If the Commission determines that the restriction is valid, you will have a minimum of 21 days to comply with this ruling. If you remove your antenna during this period, in most cases you cannot be fined. However, this 21-day grace period does not apply if the FCC rule does not apply to your installation (for example, if the antenna is installed on a condominium general common element or hanging outside beyond an apartment balcony). If the FCC rule does not apply at all in your case, the 21-day grace period does not apply.

Q: Who do I call if my town, community association or landlord is enforcing an invalid restriction?

A: Call the Federal Communications Commission at (888) CALLFCC (888-225-5322), which is a toll-free number, or 202-418-7096, which is not toll-free. Some assistance may also be available from the direct broadcast satellite company, multichannel multipoint distribution service, television broadcast station, or fixed wireless company whose service is desired.

Links to Relevant Orders and the Rule

- (First) Report and Order, FCC 96-328, released August 6, 1996: [[Text Version](#) | [WordPerfect Version](#)]
- Declaratory Ruling, Star Lambert, DA 97-1554, released July 27, 1997: [[Text](#)]
- Declaratory Ruling, Jay Lubliner, DA 97-2188, released October 14, 1997: [[Text](#)]
- Declaratory Ruling, Michael MacDonald, DA 97-2189, released October 14, 1997: [[Text](#)]
- Declaratory Ruling, Omnivision, DA 97-2187, released October 14, 1997: [[Text](#)]
- Declaratory Ruling, Wireless Broadcasting Systems (WBSS), DA 97-2506, released November 28, 1997: [[WordPerfect](#) | [Text](#)]
- Declaratory Ruling, Victor Frankfurt, DA 97-2305, released December 31, 1997: [[Text](#)]
- Declaratory Ruling, Jason Peterson, DA 98-0188, released February 4, 1998: [[Text](#)]
- Declaratory Ruling, Jordan Lourie, DA 98-1170, released June 17, 1998: [[WordPerfect](#) | [Text](#)]
- Declaratory Ruling, James Sadler, DA 98-1284, released July 1, 1998: [[WordPerfect](#) | [Text](#)]
- Memorandum Opinion and Order, Denial of Application of Review of Declaratory Ruling for Jay Lubliner (above), FCC 98-201, released August 21, 1998: [[WordPerfect](#) | [Text](#)]

- Order on Reconsideration, FCC 98-214, released September 25, 1998: [[WordPerfect](#) | [Text](#)]
- Second Report and Order, FCC 98-273, released November 20, 1998: [[Text](#) | [WordPerfect](#) | [Acrobat](#) | [News Release and Statements](#)]
- Declaratory Ruling, Stanley and Vera Holliday, DA 99-2132, released October 8, 1999: [[MSWord](#) | [Acrobat](#)]
- Second Order on Reconsideration, FCC 99-360, released November 24, 1999: [[Text](#) | [MSWord](#)]
- Declaratory Ruling, Bell Atlantic Video, DA 00-927, released April 26, 2000: [[MSWord](#) | [Acrobat](#)]
- Competitive Networks Report and Order, FCC 00-366, released October 25, 2000: [[Text](#) | [MSWord](#) | [Acrobat](#) | [News Release and Statements](#)]
- Declaratory Ruling, Victor Frankfurt, DA 01-0153, released February 7, 2001: [[MSWord](#) | [Acrobat](#)]
- Declaratory Ruling, Corey Roberts, DA 01-1276, released May 24, 2001: [[MSWord](#) | [Acrobat](#)]
- Memorandum Opinion and Order, Denial of Application of Review of Declaratory Ruling for Victor Frankfurt (above), FCC 03-210, released August 27, 2003 : [[MSWord](#) | [Acrobat](#)]
- Memorandum Opinion and Order, Philip Wojcikewicz, DA 03-2971, released September 29, 2003: [[MSWord](#) | [Acrobat](#)]
- [OTARD Rule, 47 C.F.R. Section 1.4000.](#)

GUIDANCE ON FILING A PETITION

Q: What are the procedural requirements for filing a Petition for Declaratory Ruling or Waiver with the Commission?

A: There is no special form for a petition. You may simply describe the facts, including the specific restriction(s) that you wish to challenge. If possible, attach a copy of the restriction(s) and any relevant correspondence. If this is not possible, be sure to include the exact language of the restriction in question with the petition. General or hypothetical questions about the application or interpretation of the rule cannot be accepted as petitions.

Petitions for declaratory rulings and waivers must be served on all interested parties. An entity seeking to impose or maintain a restriction must include with its petition a proof of service that it has served the affected residents. Similarly, an antenna user seeking to challenge the permissibility of a restriction must include with the petition a proof of service that the antenna user has served the restricting entity with a copy of the Petition.

If you are an antenna user, you must serve a copy of the Petition on the entity seeking to enforce the restriction (*i.e.*, the local government, community association or landlord). If you are a local government, community association or landlord, you must serve a copy of the Petition on the residents in the

community who currently have or wish to install antennas that will be affected by the restriction your Petition seeks to maintain. For example, if a homeowners' association files a petition seeking a declaratory ruling that its restriction is not preempted and is seeking to enforce the restriction against a specific resident, service must be made on that specific resident. The homeowners' association will not be required to serve all other members of the association, but must provide reasonable, constructive notice of the proceeding to other residents whose interests may foreseeably be affected. This may be accomplished, for example, by placing notices in residents' mailboxes, by placing a notice on a community bulletin board, or by placing the notice in an association newsletter. If a local government seeks a declaratory ruling or a waiver from the Commission, the local government must take steps to afford reasonable, constructive notice to residents in its jurisdiction (*e.g.*, by placing a notice in a local newspaper of general circulation). Proof of constructive notice must be provided with a petition. In this regard, the petitioner should provide a copy of the notice and an explanation of where the notice was placed and how many people the notice might reasonably have reached.

Finally, if a person files a petition or lawsuit challenging a local government's ordinance, an association's restriction, or a landlord's lease, the person must serve the local government, association or landlord, as appropriate. You must include a "proof of service" with your petition. Generally, the "proof of service" is a statement indicating that on the same day that your petition was sent to the Commission, you provided a copy of your petition (and any attachments) to the person or entity that is seeking to enforce the antenna restriction. The proof of service should give the name and address of the parties served, the date served, and the method of service used (*e.g.*, regular mail, personal service, certified mail).

If you wish to file either a Petition for Declaratory Ruling or a Petition for Waiver pursuant to the Commission's Over-the-Air Reception Devices Rule (47 CFR Section 1.4000), you must file an original and two copies of your Petition on the following address:

**Office of the Secretary
Federal Communications Commission
445 12th Street, S.W.
Washington, D.C. 20554
Attn: Media Bureau**

Q: What are the substantive requirements for filing a petition for waiver or declaratory ruling?

A: To file a Petition for Waiver, follow the requirements in Section 1.4000(c) of the rule. The local government, community association or landlord requesting the waiver must demonstrate "local concerns of a highly specialized or unusual nature." The petition must also specify the restriction for which the waiver is sought, or the petition will not be considered.

To file a Petition for Declaratory Ruling, follow the requirements set forth in Section 1.4000(d) of the rule. Set out the restriction in question so that we can determine whether it is permissible or prohibited under the rule. In a Petition for Declaratory Ruling, the burden of demonstrating that a particular

restriction complies with the rule is on the entity seeking to impose the restriction (*e.g.*, the local government, community association or landlord).

We recommend that you include the language of the restriction in question, as well as a daytime telephone number, with your petition.

While a petition for declaratory ruling or waiver is pending with the Commission or a court, the restriction in question may not be enforced unless it is necessary for safety or historic preservation. No fines or penalties, including attorneys fees, may be imposed by the restricting entity while a petition is pending. If the restriction is found to be permissible, the antenna users subject to the ruling will generally have at least 21 days in which to comply before a fine or penalty is imposed.

- FCC -

Antenna Restrictions, Power Restrictions, RFI Problems, or Limited Space keeping you off the air?

There are SOLUTIONS. See how others do it! Here are some helpful LINKS. Build your own hidden stealth and secret antennas

Learn how to build, hide and operate indoor and outdoor Ham antennas without causing RFI problems. Some of these designs were taken from pirate operations and applied to legal radio. I do not condone pirate radio, but why not apply their hiding techniques with proven ham antenna designs and theory.

*Newsletter archives dealing with condo and apartment Radio Station invisible antennas, interference solutions and more.

[The CONDO COMMUNICATOR](#)

*News Reflector dealing with low power, super efficient concealed ham antennas, solving the impossible, and having fun doing it. Their designs work with 100w stuff too!

[QRP-L REFLECTOR updated hourly](#)

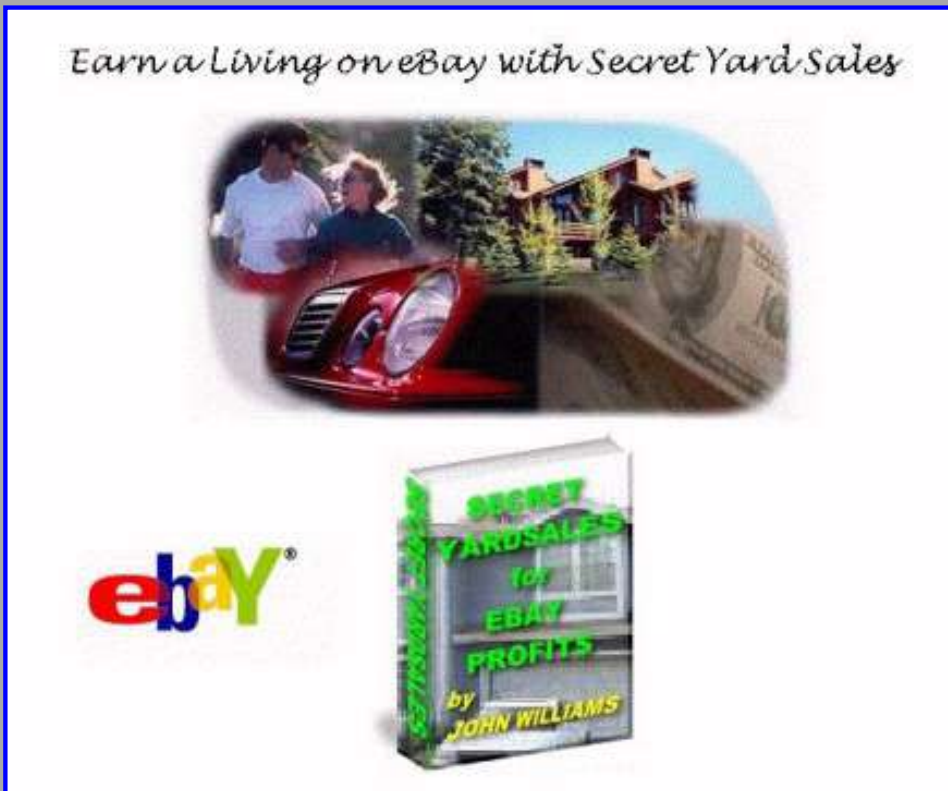

Hide your antenna in something else. Extreme Measure for the most severely restricted environment. When NOBODY can know you have a transmitter. For apartment Balcony, Great working! Hanging "HUMMINGBIRD FEEDER" bird feeder 10-40m HF Antenna Instructions. This hides the outside loading coil so your random wire will tune up on 10-40m. Puts substansial portion of your radiated RF outside your apartment-condo. Here is a brief description until I put up a page: Buy a plastic hummingbird feeder with standard glass syrup jar. Replace syrup bottle with a 2 liter soda bottle. Threads of soda bottle match feeder bottom perfectly, plus plenty of room to put a large COIL inside. Cut bottom 5" of bottle off. Save it to slide back over remainder later after you instal a 80-100 turn air or ceramic core coil. No plastic cores. Can get hot! on some freqs. Coil turn spacing min= space of same wire diameter as gap between turns. Larger gaps ok. Solder 10',(or more), wire to top of coil, run through bottle end to hang. Use a foot or two to hang and run remainder painted, hidden behind eves etc. horizontally for "INVERTED L" capacity hat. Solder a random wire to bottom of coil to exit out of bottom of feeder to your tuner (tune with tuner as a random wire. use a counterpoise, a real or artificial ground.) Small guage Black insulated wire is hardest to see. Best to hide most of feed wire, but do not run parallel next to other parallel metal objects,(ok to cross metal. just don't run along lengths of metal rails, sliding doors, extension cords, etc.). If ask what is "THAT" wire for, say, "It is a special ultrasonic LARGE bird repeller" and it only repells one foot from my feeder. Tell them how safe it is. Make up details, go on and on about technical details etc. They are sorry they ask and leave. This always works for me. Paint soda bottle fire engine red to hide coil and match rest of feeder. The longer the feed

wire the better. The more turns and diameter of coil the better. You want to increase your chances of a "PEAK CURRENT POINT" occurring somewhere, (that is why so many turns), in the coil for lowest angle radiation possible under such compromised conditions. (sorry no more syrup). Safe for birds. Works great and even the most snoopy manager neighbor will never suspect a pirate like antenna. This description and photos will get you started. You can easily improvise until I post more construction photo details.



10-40m Hummingbird feeder antenna in use

LOOK AT THESE 10-30m and 40m balcony antennas. 10-30m is an AEA IsoLoop magnetic loop, (MFJ type loop), and a 40m hamstick bundled with fishing poles to hide. Stick is tuned with wire tuner and artificial ground counter poise. Loop is covered with plastic tarp to hide. I get average 559 sig reports. Loop works DX on CW! I can't say enough about these loops. They really perform. Hamstick equals a 100w mobile for performance. It's fun and I get to keep my hobby where not allowed.



Invisible Amateur Antennas-- antenna special on hard-core- dx.com Plans, Plans and more Plans. These guys left nothing out!!!

[Hard-Core-DX Hidden antennas](#)

AMATEUR RADIO ANTENNA PROJECTS Links to many antenna designs, radio kits, designs, concealed station ideas.

[from AC6V~ AMATEUR RADIO ANTENNA PROJECTS BIG SITE!](#)

FREE RADIO MANUALS and SCHEMATICS

[GIANT collection all FREE downloads](#)

"Secrets" of a Successful Stealth Operator

[Stealth Operator Secrets](#)

ANT-VENTURES HAM ANTENNAS

[Stealth Antennas made for you](#)

ARRL Web: ARRL Product Catalog

[ARRL amateur stuff](#)

Hi-Q Antennas for HF Ham Radio Mobile Operation

[Hi-Q](#)

ac6ts@n2.net

Support your RADIO HOBBY-Work from your condo or apartment. Earn EXTRA INCOME! Easily find collectible radios and ham gear in your area to RESELL on EBay for GIANT PROFITS! LEARN the secrets of "BUY BY APPOINTMENT". Proven AUTO-PILOT METHODS GENERATE BUYING OPPORTUNITIES 7 days a week. Your phone will ring like crazy with anxious local sellers offering discounted GEAR. [Click Here Step by Step METHODS REVEALED](#)

collectiblehelp.com

[FastCounter by bCentral](#)



[web hosting](#) • [domain names](#) • [web design](#)
[online games](#) • [digital cameras](#)
[photo album](#) • [advertising online](#)



...and Tons of Books!

<http://www.radio-ware.com>

Find on this site...

[Site Index](#)

- [Exams](#) Search site: Call sign search:
- [Clubs](#)
- [Hamfests](#)
- [Addresses](#)

ARRL Member Login...

Username: Password:

[Register](#)

Quick Links...

- [Join or Renew](#)
- [Catalog & Store](#)
- [ARRL Courses](#)
- [Classifieds](#)
- [Getting Started](#)

[Operating Activities](#)[Licensing](#)[News/Bulletins](#)[Services](#)[Educational](#)[Public Service](#)[Support](#)[Donate to ARRL](#)[ARRL Info](#)[Text-only/Printable](#)

Previous: [Surfin': HF Propagation Software From Your Uncle Sam](#)

Next: [FCC May Be Able to Resume Vanity Processing Soon](#)

ARRL Products:
Digital Communications
[\(More\)](#)



[The ARRL Image Communications Handbook](#) -- Use

Amateur Radio to see and talk with other hams! Enjoy the imaging modes: NBTv, ATV, SSTV and WEFAX.



[802.11 Wireless Networks: The Definitive Guide](#) --

Creating and administering wireless networks.



[Digital Signal Processing Technology](#) --

Essentials of the Communications Revolution. An understandable presentation and reference on DSP in contemporary communications technology.

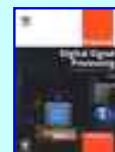

[Practical Digital Signal Processing](#) -

- Now Shipping! -
 Gain a working knowledge of DSP applications, including

ARRL Offers On-Line "Antenna Restrictions 'How To' Chart"

NEWINGTON, CT, Jan 7, 2002--The ARRL Regulatory Information Branch has made available what might be called a "triage center" for amateurs facing the prospect of dealing with various roadblocks to erecting an antenna system at their residence. The new "[Antenna Restrictions 'How To' Chart](#)" page offers three separate outlines that help the user to logically work through issues involving local government zoning restrictions; deed covenants, conditions and restrictions (CC&Rs); or rental/lease restrictions relating to antenna structures.

The prime focus is on dealing with local zoning restrictions to putting up an antenna structure and how to make the best possible case at a local regulatory board hearing. Some of the advice there also applies to CC&Rs and rental/lease situations too.

"Remember: at the hearing, your presentation will be 80% of the battle, and 100% of the basis for any record, if the case ends up going to court," the "Important Notice" on the page advises.

Each "how to" outline is structured around a series of questions--much like a logic or flow chart. Depending on the answer, the user is referred to specific information or additional resources. The page also offers some step-by-step suggestions. For example, the local government zoning outline suggests 10 steps to those seeking to change an overly restrictive local amateur antenna ordinance. One of them is to obtain the ARRL book [Antenna Zoning for the Radio Amateur](#) (\$49.95; order Item 8217 from ARRL via the Online Store or order by calling toll-free

888-277-5289), which offers detailed information on working with local governments. Written by attorney Fred Hopengarten, K1VR, the book describes proven techniques and strategies that amateurs can employ in efforts to obtain an antenna-structure permit.

As the page emphasizes up front, however, neither this book nor the outlines on the "Antenna Restrictions 'How To' Chart" page are intended as substitutes for advice from an attorney.

The local government zoning outline also asks, "Has your state codified PRB-1?" and, if the answer is no, offers suggestions and information for amateurs who would like their legislature to incorporate the limited federal preemption known as PRB-1 into their state's laws. So far, only 13 states have done so, but bills are still in the works in a few others.

The page offers limited guidance to those confronting CC&Rs--an issue facing more and more amateurs these days--and to those who rent or lease their homes and still want to be able to install an antenna--a situation where PRB-1 does not apply. In both instances, affected amateurs are advised to develop and present logical and persuasive cases for being allowed to install an antenna system--much as they would have to do when dealing with a local government.

communications and process control.



ARRL's HF Digital Handbook -- **Now Shipping!** -- 3rd edition. Use your computer to talk to the world!

 [Previous: Surfin': HF Propagation Software From Your Uncle Sam](#)

 [Next: FCC May Be Able to Resume Vanity Processing Soon](#)

Page last modified: 02:33 PM, 07 Jan 2002 ET

Page author: awextra@arrl.org

Copyright © 2002, American Radio Relay League, Inc. All Rights Reserved.



Ham University

CW!
General

Tech!
Extra!

Find on this site...

[Site Index](#)

•[Exams](#) Search site: Call sign search:
•[Clubs](#)
•[Hamfests](#)
•[Addresses](#)

ARRL Member Login...

Username: Password:

[Register](#)

Quick Links...

•[Join or Renew](#)
•[Catalog & Store](#)
•[ARRL Courses](#)
•[Classifieds](#)
•[Getting Started](#)

[Operating Activities](#) [Licensing](#) [News/Bulletins](#) [Services](#) [Educational](#) [Public Service](#) [Support](#) [Donate to ARRL](#) [ARRL Info](#) [Text-only/Printable](#)

[ARRL Products Catalog](#)

Quick & Easy Ordering of the BEST Amateur Radio Publications

Category:

Product Search:

[Shipping](#) · [Find a dealer](#) · [Order by item #](#) · [Help/Customer Service](#) · [List all products](#) · [Product Notes](#)

Order Toll-Free 1-888-277-5289

Antenna Zoning for the Radio Amateur

-- By Fred Hopengarten, K1VR

Everything you and your attorney need to know to obtain a permit for your antenna-support system.

Don't let the confusing tangle of ordinances and by-laws keep you from installing the antenna you need in order to communicate effectively! In recent years, many cities and towns have enacted ordinances designed mainly to regulate cellular antenna structures. Unfortunately, hams have sometimes been caught in the backlash of regulatory overkill. This book describes proven techniques and strategies that a ham and his or her attorney can use to obtain an antenna-structure permit (also includes material on Canadian law and regulation).

Contents

- Introduction: Why This Book Was Written
- 1: Principles That Will Help You Win
- 2: The Process in a Nutshell
- 3: Your Winning Team
- 4: Basic Preparations
- 5: Getting to Know the Players
- 6: Possible Objections
- 7: Preparing the Permit Application
- 8: Public Hearings—Your Big Moment in the Spotlight
- 9: Deliberations and Decisions
- 10: Now, Get the Permit and Build Your Antenna
- 11: Awkward Post-Permit Situations

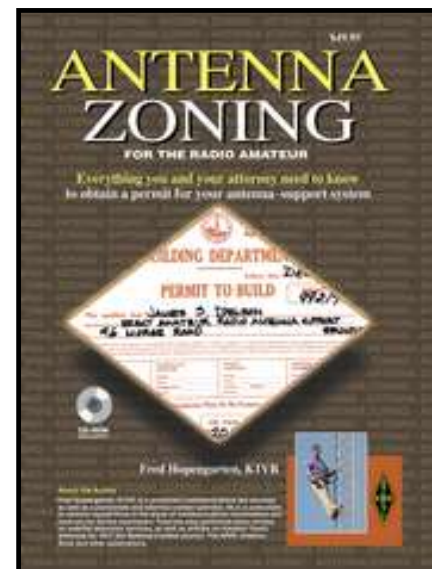

- 12: Appeals
- 13: Tower and Antenna Regulation in Canada [by Tim Ellam, VE6SH]
- 14: Bibliography
- Appendix A: The Law
- Appendix B: Drafting a Bylaw, or Redrafting a Bylaw
- Appendix C: Lawsuits

CD-ROM included containing case law, customizable forms and additional legal reference material. Windows and Macintosh compatible.

Online Special \$40 (was \$49.95)

First edition, second printing. © 2001-2002, The American Radio Relay League, Inc. (ISBN: 0-87259-821-7)
#8217 -- \$40.00

Online Special!

[Add to shopping basket](#)

Page last modified: 02:38 PM, 18 Sep 2002 ET

Page author: webmaster@arrl.org

Copyright © 2002, American Radio Relay League, Inc. All Rights Reserved.

Smartuners for Stealth Antennas

Download your copy today! See [Brochures and Publications](#).

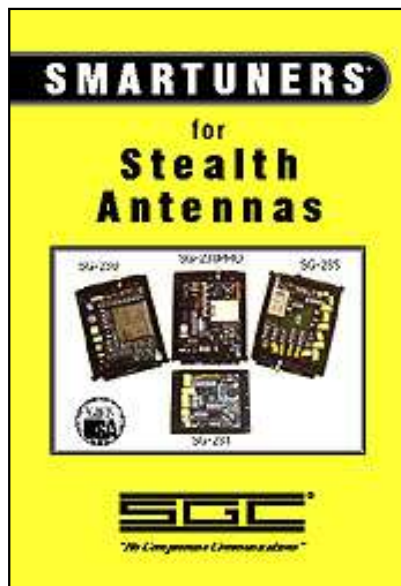

ARE YOU INSTALLING A NEW ANTENNA SYSTEM?

Get your facts from the professionals in the newest SGC publication!

A book about theory and installation of effective HF antenna systems. For novice to experienced HF users, "Smartuners for Stealth Antennas" shows you antenna installations tried and proven using [SGC Smartuners](#). Dozens of illustrations actually show you how to set up your very own practical *and* "hidden" HF antenna system.

Chapters include:

- Tuner, Coupler, what is the difference?
- Why an antenna coupler?
- Basic antenna theory
- Antenna types
- Practical Installations
- Ground systems
- Indoor antennas
- Construction techniques

SGC, Inc.

1-800-259-7331

13737 SE 26th St., Bellevue, WA 98005 USA

Tel: 425-746-6310 | Fax: 425-746-6384

E-mail: sgc@sgcworld.com

© Copyright 2002, 2003, 2004 by SGC, Inc. All Rights Reserved.

Antenna Restrictions, Power Restrictions, RFI Problems, or Limited Space keeping you off the air?

There are SOLUTIONS. See how others do it! Here are some helpful LINKS. Build your own hidden stealth and secret antennas

Learn how to build, hide and operate indoor and outdoor Ham antennas without causing RFI problems. Some of these designs were taken from pirate operations and applied to legal radio. I do not condone pirate radio, but why not apply their hiding techniques with proven ham antenna designs and theory.

*Newsletter archives dealing with condo and apartment Radio Station invisible antennas, interference solutions and more.

[The CONDO COMMUNICATOR](#)

*News Reflector dealing with low power, super efficient concealed ham antennas, solving the impossible, and having fun doing it. Their designs work with 100w stuff too!

[QRP-L REFLECTOR updated hourly](#)

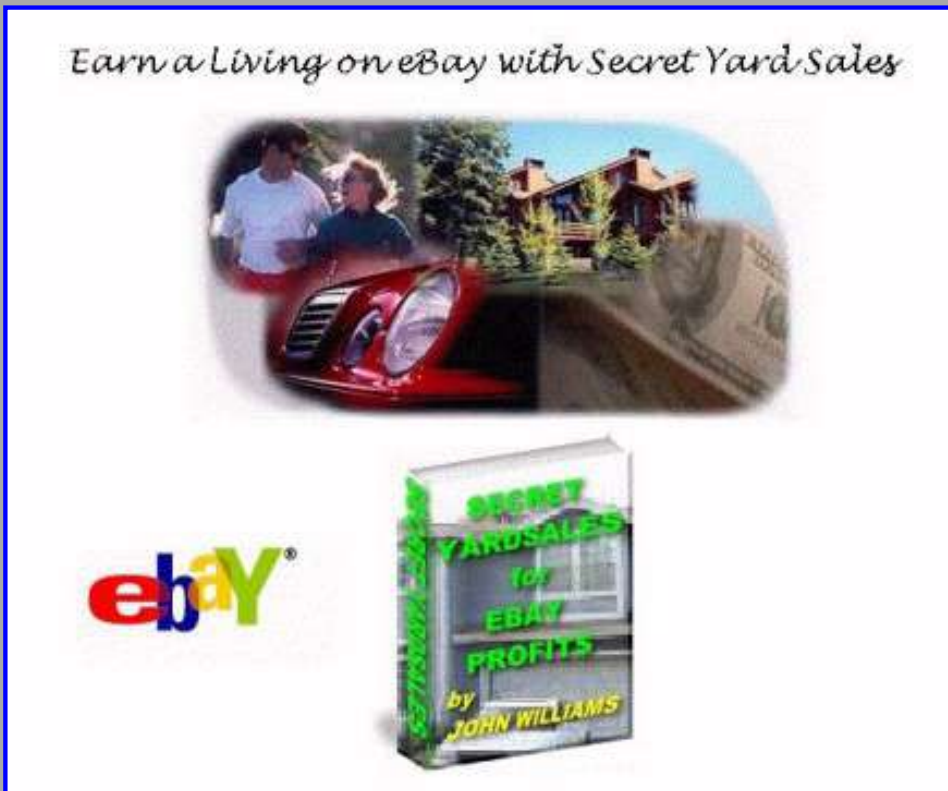

Hide your antenna in something else. Extreme Measure for the most severely restricted environment. When NOBODY can know you have a transmitter. For apartment Balcony, Great working! Hanging "HUMMINGBIRD FEEDER" bird feeder 10-40m HF Antenna Instructions. This hides the outside loading coil so your random wire will tune up on 10-40m. Puts substansial portion of your radiated RF outside your apartment-condo. Here is a brief description until I put up a page: Buy a plastic hummingbird feeder with standard glass syrup jar. Replace syrup bottle with a 2 liter soda bottle. Threads of soda bottle match feeder bottom perfectly, plus plenty of room to put a large COIL inside. Cut bottom 5" of bottle off. Save it to slide back over remainder later after you instal a 80-100 turn air or ceramic core coil. No plastic cores. Can get hot! on some freqs. Coil turn spacing min= space of same wire diameter as gap between turns. Larger gaps ok. Solder 10',(or more), wire to top of coil, run through bottle end to hang. Use a foot or two to hang and run remainder painted, hidden behind eves etc. horizontally for "INVERTED L" capacity hat. Solder a random wire to bottom of coil to exit out of bottom of feeder to your tuner (tune with tuner as a random wire. use a counterpoise, a real or artificial ground.) Small guage Black insulated wire is hardest to see. Best to hide most of feed wire, but do not run parallel next to other parallel metal objects,(ok to cross metal. just don't run along lengths of metal rails, sliding doors, extension cords, etc.). If ask what is "THAT" wire for, say, "It is a special ultrasonic LARGE bird repeller" and it only repells one foot from my feeder. Tell them how safe it is. Make up details, go on and on about technical details etc. They are sorry they ask and leave. This always works for me. Paint soda bottle fire engine red to hide coil and match rest of feeder. The longer the feed

wire the better. The more turns and diameter of coil the better. You want to increase your chances of a "PEAK CURRENT POINT" occurring somewhere, (that is why so many turns), in the coil for lowest angle radiation possible under such compromised conditions. (sorry no more syrup). Safe for birds. Works great and even the most snoopy manager neighbor will never suspect a pirate like antenna. This description and photos will get you started. You can easily improvise until I post more construction photo details.



10-40m Hummingbird feeder antenna in use

LOOK AT THESE 10-30m and 40m balcony antennas. 10-30m is an AEA IsoLoop magnetic loop, (MFJ type loop), and a 40m hamstick bundled with fishing poles to hide. Stick is tuned with wire tuner and artificial ground counter poise. Loop is covered with plastic tarp to hide. I get average 559 sig reports. Loop works DX on CW! I can't say enough about these loops. They really perform. Hamstick equals a 100w mobile for performance. It's fun and I get to keep my hobby where not allowed.



Invisible Amateur Antennas-- antenna special on hard-core- dx.com Plans, Plans and more Plans. These guys left nothing out!!!

[Hard-Core-DX Hidden antennas](#)

AMATEUR RADIO ANTENNA PROJECTS Links to many antenna designs, radio kits, designs, concealed station ideas.

[from AC6V~ AMATEUR RADIO ANTENNA PROJECTS BIG SITE!](#)

FREE RADIO MANUALS and SCHEMATICS

[GIANT collection all FREE downloads](#)

"Secrets" of a Successful Stealth Operator

[Stealth Operator Secrets](#)

ANT-VENTURES HAM ANTENNAS

[Stealth Antennas made for you](#)

ARRL Web: ARRL Product Catalog

[ARRL amateur stuff](#)

Hi-Q Antennas for HF Ham Radio Mobile Operation

[Hi-Q](#)

ac6ts@n2.net

Support your RADIO HOBBY-Work from your condo or apartment. Earn EXTRA INCOME! Easily find collectible radios and ham gear in your area to RESELL on EBay for GIANT PROFITS! LEARN the secrets of "BUY BY APPOINTMENT". Proven AUTO-PILOT METHODS GENERATE BUYING OPPORTUNITIES 7 days a week. Your phone will ring like crazy with anxious local sellers offering discounted GEAR. [Click Here Step by Step METHODS REVEALED](#)

collectiblehelp.com



[web hosting](#) • [domain names](#) • [web design](#)
[online games](#) • [digital cameras](#)
[photo album](#) • [advertising online](#)

I work as a Building Engineer for an aerospace company that specializes in antenna systems. I hold an Extra Class License

N0HC's

Ham Radio & More's

Low Profile Operating & High Profile Fun

Hi, my name is Cliff

A lot of Hams live in areas that do not allow visible outside antennas like these in the back ground. This page is intended to provide some ideas for low profile operation.

AMATEUR RADIO - Updated!

WINDSURFING

MX PICTURES

RC GLIDERS

MARTIAL ARTS



Links to other sites on the Web



Train Racing!



Out of This World Radi



NEW! AMATEUR RADIO LINKS

Look for updates on this page.

© 2002 cholloway14@attbi.com

DXZONE.COM

The DXZone

DXZONE.COM

Visit DXZone - Click Here

This page hosted by



Get your own Free Home Page

Menu:



My Daughter's Page - New!





AT-100Pro Memory Autotuner

Only \$219



Find on this site...

[Exams](#) Search site: Call sign search:
[Clubs](#)
[Hamfests](#)
[Addresses](#)

Site Index

ARRL Member Login...

Username: Password:

[Register](#)

Quick Links...

[Join or Renew](#)
[Catalog & Store](#)
[ARRL Courses](#)
[Classifieds](#)
[Getting Started](#)

[Operating Activities](#) | [Licensing](#) | [News/Bulletins](#) | [Services](#) | [Educational](#) | [Public Service](#) | [Support](#) | [Donate to ARRL](#) | [ARRL Info](#) | [Text-only/Printable](#)

ARRL Products Catalog

Quick & Easy Ordering of the BEST Amateur Radio Publications

Category:

Product Search:

[Shipping](#) · [Find a dealer](#) · [Order by item #](#) · [Help/Customer Service](#) · [List all products](#) · [Product Notes](#)

Order Toll-Free 1-888-277-5289

Stealth Amateur Radio

-- **Operate From Anywhere**
by Kirk A. Kleinschmidt, NTOZ.

Adventure into the world of hidden stations and invisible antennas! Set up and operate a station without calling attention to yourself. Successfully operate a low power (QRP) station. Install safe antennas, including indoor antennas. Build invisible antennas. Install and operate a mobile station, to "get away" from radio-forbidden locations. Operate a portable station from a campground, motel room, picnic area, mountaintop or other location. Handle interference from your station to nearby consumer electronics devices as well as to your station from other nearby devices. Use this book and enjoy operating from just about anywhere!

First edition, second printing, 2001. © 1999-2001, The American Radio Relay League, Inc. (ISBN: 0-87259-757-1) #7571 -- \$14.95

[Add to shopping basket](#)

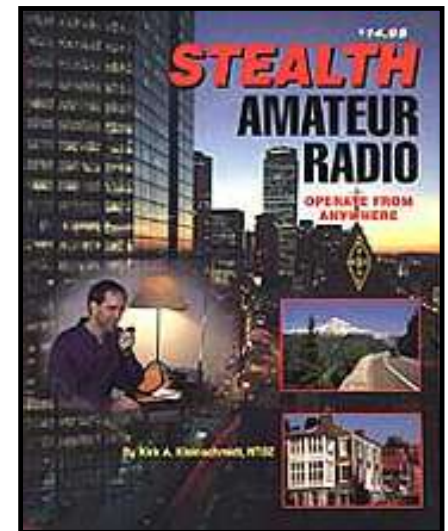

Page last modified: 02:38 PM, 18 Sep 2002 ET

Page author: webmaster@arrl.org

Copyright © 2002, American Radio Relay League, Inc. All Rights Reserved.



| |
|--|
| |
| |
| |
| |
| |
| |
| |
| |
| |



Radio Gear for Active Ham Ops^(sm)

RADIALWAVE AMATEUR RADIO PRODUCTS

[Installation Information](#)

Now accepting payments through secure PayPal



FOR USE WITH FULL SIZE HF VERTICAL ANTENNAS!

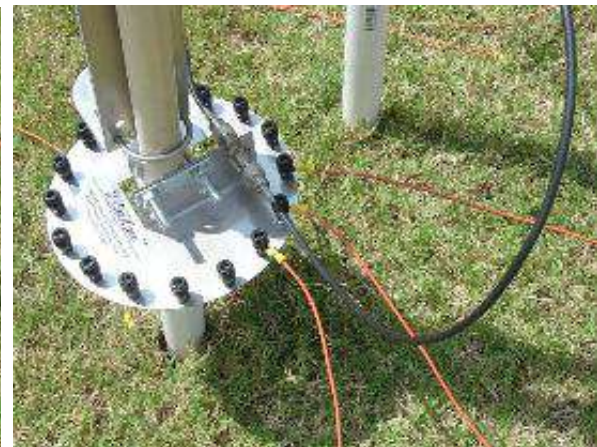

[FREE HOMEBREW ANTENNA ANALYZER WORKSHEET \(Requires Adobe Reader\)](#)

[Click Here for Radial Wire Length Information.](#)

RADIALWAVE GREAT FOR DEED RESTRICTED BASE STATIONS, QRP, BACKPACKING, FIELD DAY, OR EMERGENCY COMMUNICATIONS.

Shopping Cart

Fast, Secure and Convenient with Buyer Protection

RadialWave Systems for HF Vertical Antennas



Use with Full size HF Vertical Antennas

- Hustler 4BTV, 5BTV, 6BTV HF**
- Butternut HF-9V, HF-6V, HF-2V**
- Force 12 HF Verticals**
- Other HF Vertical Antennas**

Use the EZRadial Ground Radial/Counterpoise for full size HF Vertical Antennas.

Experiment with different ground radial patterns to obtain different radiation patterns.

Can be used with two or more antennas and phased transmission lines for directional radiation patterns.

| | | | |
|---|---|---|--|
| EZRW-R | EZRadial Full Size RadialWave for Full HF Vertical Antennas (w/ accy) | \$55 | More Information and Ordering |
| EZRW-D | EZRadial Full Size RadialWave for Full HF Vertical Antennas (w/ accy) | \$40 | More Information and Ordering |
| RadialWave Systems for HF Vertical Antenna | | | |
|  | | Use the Portable RadialWave Ground Radial/Counterpoise System with vertical long wire radiators, coil and whip homebrew antennas, vertical monopoles, "bugcatcher" antennas, or base or center loaded antennas. | |
| RW-DX | Portable Radial/Counterpoise System (w/ wire) | \$40 | More Information and Ordering |
| RW-R | Regular Ground Radial/Counterpoise System (w/o wire) | \$30 | More Information and Ordering |
| Antenna Bags | | | |
| RW-BG-6 | Vertical and Monopole Antenna bag (6 ft length) | \$45 | More Information and Ordering FREE CALSIGN MONOGRAM ON ANTENNA BAG |
| Go Bag | | | |
| RW_GOBAG | "Go Bag" | \$30 | More Information and Ordering FREE CALSIGN MONOGRAM ON GO BAG |
| Antennas | | | |

| | | | |
|--|---|--|---|
|  | | More Antennas and Antenna Mounts below | |
| 6M | 6 Meter Vertical Monopole | \$20 | More Information and Ordering |
| 10M | 10 Meter Vertical Monopole | \$20 | More Information and Ordering |
| 12M | 12 Meter Vertical Monopole | \$20 | More Information and Ordering |
| 15M | 15 Meter Vertical Monopole | \$20 | More Information and Ordering |
| 17M | 17 Meter Vertical Monopole | \$20 | More Information and Ordering |
| 20M | 20 Meter Vertical Monopole | \$20 | More Information and Ordering |
| 40M | 40 Meter Vertical Monopole | \$20 | More Information and Ordering |
| 75M | 75 Meter Vertical Monopole | \$25 | More Information and Ordering |
| HFPACK | Pack of 5 Vertical Monopoles (10M, 15M, 20M, 40M, 75M) | \$90 | More Information and Ordering |
| HF Dipole Antennas | | | |
| DI_ANT20 | 20 Meter Dipole (made from 2-20 Meter Verticals and Center Mount) | \$40 | More Information and Ordering |
| DI_ANT40 | 40 Meter Dipole (made from 2-40 Meter Verticals and Center Mount) | \$40 | More Information and Ordering |
| DI_ANT75 | 75 Meter Dipole (made from 2-75 Meter Verticals and Center Mount) | \$50 | More Information and Ordering |
| PSK 31 Adapters | | | |

| | | | |
|----------------------------------|---|------|---|
| | Saratoga EZ PSK for ICOM 703/706  | \$45 | More Information and Ordering |
| | Saratoga EZ PSK for Yaesu 817/857/897  | \$45 | More Information and Ordering |
| RadialWave Components | | | |
| RW-D | Finished Radial Wave Center Disk | \$20 | More Information and Ordering |
| RW-U | Unfinished RadialWave Center Disk | \$12 | More Information and Ordering |
| RW-SK4 | Stakes (4) | \$4 | More Information and Ordering |
| RW-SK8 | Stakes (8) | \$5 | More Information and Ordering |
| RW-BP | Binding Posts (4) | \$4 | More Information and Ordering |
| RW-W | Copper Wire (135 Feet, 18 AWG) | \$10 | More Information and Ordering |
| RW-SF | Safety Flags | \$3 | More Information and Ordering |
| Radial Wave HT Antennas | | | |
| HT-1BNC | HT 7.5" Dual Band 144/430 Antenna (BNC) | \$15 | More Information and Ordering |
| HT-1SMA | HT 8" Dual Band 144/430 Antenna (SMA) | \$15 | More Information and Ordering |
| RadialWave Antenna Mounts | | | |
| MAG-M3 | 3" dia Magnetic Mount 3/8 * 24 Female | \$13 | More Information and Ordering |
| MAG-M4 | 4" dia Magnetic Mount 3/8 *24 | \$16 | More Information and Ordering |

| | | | |
|--------------------------------|--|------|---|
| MAG-M5 | 5" dia Magnetic Mount 3/8 *24 | \$16 | More Information and Ordering |
| SM-M | RadialWave Heavy-Duty Surface Mount (SO-239) | \$5 | More Information and Ordering |
| DI-M | RadialWave Monopole Dipole Mount | \$10 | More Information and Ordering |
| MM-M | RadialWave Heavy-Duty Mirror Mount (SO-239) | \$7 | More Information and Ordering |
| UHF | RadialWave UHF Double Female | \$3 | More Information and Ordering |
| Additional Antenna Bags | | | |
| RW_BG3.5 | HF Antenna/Eqpt. Bag (3.5 ft length) | \$55 | More Information and Ordering FREE CALLSIGN MONOGRAM ON ANTENNA BAG |
| RW_BG3 | Portable Antenna Bag (3 ft length) | \$30 | More Information and Ordering FREE CALLSIGN MONOGRAM ON ANTENNA BAG |
| RW_BG2 | Portable Antenna Bag (2 ft length) | \$30 | More Information and Ordering FREE CALLSIGN MONOGRAM ON ANTENNA BAG |

RadialWave LLC, Copyright 2004

Clif's Ham Radio Page

Welcome to Clif's ham radio connection. On this page you'll find [links](#) to other interesting sites. It is not my intention to create the end all page with links to everywhere but I've included a few of the ones that I think are most pertinent.

My particular area of interest is in high frequency (HF) antennas in less than optimal conditions. Most of the available programs used to analyze antennas today assume that the antenna is mounted in free space or mounted a uniform distance above ground - conditions that unfortunately many hams can get nowhere near achieving. Since the software tools are somewhat limited in what can be simulated I'm instead looking for the apartment dwellers, condo owners and other restricted antenna users with any experience. Your experience level is not important - what you did and what the results were are more important. It doesn't matter if what you tried didn't work, just let the rest of us know so we might learn from your experience. I'm collecting data - not to analyze but rather to show empirically what works and what doesn't. Send me all your details, in particular try to provide the following information:

- description of the antenna
- where and how it was mounted such as in the attic, under the eaves, in the middle of a group of trees etc.
- Typical transmitter power
- Contacts made
- Anything else you think might help another ham

I'll make the data available here as case studies. I've included the results of my own experiences to give you an idea. Got comments or questions? Ideas of how to make this site better? [Email me!](#)

As more data becomes available, the format of this page may change, however it will remain the entry point into the database with the same name and location so go ahead and bookmark it.

Summary of experience with restricted space antennas

First and foremost hams faced with restrictive antenna constraints should not lose faith. You still can operate successfully although you will never be able to out-slug the hams running linears into beams mounted high up on towers. If you build a hidden outdoor antenna you will probably be limited to 100 watts or less due to the wire sizes and insulator types. If the antenna is mounted indoors, your power will still be restricted due to health hazards to yourself or other family members (arcing or RF energy) or due to interference with televisions, computers, VCRs, telephones, etc. However the QRP hams continue to show us that QSOs can and do happen with regularity at low power outputs. In general you should strive to build an antenna as high and as close to full size as your situation allows. If elements need to be bent to fit the space that's ok - just try not to have them double back on themselves. An antenna tuner is a must have item with almost any antenna you will build. Almost anything metal can be made to radiate RF

energy so don't despair! If you meet with success, drop me some email so we can share it with others. Some other common approaches are the flagpole vertical, the magnetic loop and slinky dipole. Another approach I want to try is to build a St. Louis Vertical which is a portable antenna that works 10m to 40m and only erect it when I'm on the air.

Case 1: 10m dipole in attic

Antenna type

Full size dipole made with #24 gauge magnet wire and ceramic insulators. Oriented approximately NNW by SSE. Actual elevation above ground was approximately 25 to 30 feet.

Structure

Two and a half story condominium unit. Shack was in upper level with the antenna mounted in the attic using cord to mount the antenna between rafters. Structure was wood frame with a stucco exterior and a composite shingle roof. Also under one half of the dipole was a forced air furnace made of galvanized steel. This heater was about 2.5 feet below the wire of the dipole. Shack was located in Southern California.

Rig Details

Icom IC725 running average of 50 watts. Coupled to antenna through RG58/U coax. Used MFJ-941E tuner to match rig to antenna.

Performance Summary

When the 10m band opened, 50 watts and my attic dipole did quite well. Most signal reports were 55 to 59. Contacts were made to Indiana, Alabama, Louisiana, Texas, Wisconsin, Kansas, Minnesota, Mississippi, Pennsylvania, North Carolina, New York, Rhode Island, Hawaii plus a few other states and even Japan!

Comments

This antenna may have done well since it was in a wood structure and the actual antenna height above ground was greater than a half wavelength. The contacts appeared consistent with the orientation of the antenna, that is most of the contact occurred broadside to the antenna.

Case 2: 40m twin lead Marconi in attic

Antenna type

This antenna was a twin lead Marconi based on information found in William Orr's **Radio Handbook**. This antenna was also fed with RG-58/U coax. In addition, a half wavelength counterpoise was attached to the coax shield/antenna junction to provide an RF ground.

Structure

This antenna was also mounted in the same attic as case 1. The twin lead was snaked around the perimeter of the attic and held in place by attaching it to the studs with cable ties. The twin lead could not be laid out in a straight line instead it was routed in a shape like a question mark where the bottom of the question mark was the feed point. The first section was about 20 feet followed by a 90 degree bend and the next 10 feet followed by another 90 degree bend and the final 3 or 4 feet. The first section was oriented roughly E-W, the second section N-S and the third section was

again E-W. The counterpoise was snaked in the other direction in a similar shape with the first section of about 25' going N-S, and the remainder going E-W.

Rig Details

Same as Case 1.

Performance Summary

As expected, this antenna didn't perform like a free space 1/4 wave vertical. It took time but the MFJ tuner would get a good match to the transmitter. Normal power used was 50 watts. Contacts ranged all around the western United States with the majority in Oregon, Washington and Northern California. There were also contacts made in Idaho, Utah, Montana, Colorado, Nevada, Alaska, British Columbia and Texas.

Comments

This antenna was used to primarily work 40m CW. On occasion it was used of 15m CW also. Signal reports were average with R's of 4 to 5, S's from 3 to 9 and T's of 9. There were very few reports of 599. The signal was getting out but not very well. Almost all the contacts were broadside to the longest section of the twinlead.

Case 3: Triband inverted V dipole under the eaves

Antenna type

This antenna was constructed as a 40m dipole and a 10m dipole with a common feedpoint. The 10m elements are built using #24 gauge magnet wire and ceramic insulators. The 40m elements are built using #18 gauge hookup wire. The apex of the inverted V is at the high point of the roofline, approximately 18 to 19' above ground. The 10m elements slant downward about 30 degrees below horizontal and remain spaced about 14 inches from the stucco surface of the wall. The 40m elements are secured under the eaves and extend about 30 feet from the apex before reaching the corners of the house where they both make 90 degree bends and continue under the eaves. At this point, the elements are only about 8 feet above ground. The major portion of both antennas are oriented N-S.

Structure

The house is a wood frame, stucco exterior, single story dwelling with a concrete tile roof. The eaves extend about 16 inches beyond the walls of the house. The house is located in Southern California.

Rig Details

Same as Case 1.

Performance Summary

So far it appears that the proximity to the structure make the 40m antenna appear electrically longer than it is physically. Only one QSO has been completed so far and that was with a station in WA. RST report was 469 but WA is off the "end" of the major axis of this antenna. At this time (7/10/97) no contacts on 10m have been completed but the band still appears dead.

Comments

With only one QSO completed, the jury is still out on this antenna. Will update this page as more as information becomes available.

Case 4: 10m dipole in attic

Antenna type

Full size dipole made with #24 gauge magnet wire and ceramic insulators. Oriented approximately NNW by SSE. Actual elevation above ground was approximately 15 to 18 feet. Dipole was not perfectly horizontal, instead it was oriented more like an inverted V with about a 15 to 20 degree slope.

Structure

Single story, single family house. Wood frame, stucco exterior walls with a concrete tile roof. Shack was located in Southern California.

Rig Details

Icom IC725 running average of 50 watts. Coupled to antenna through RG58/U coax. Used MFJ-941E tuner to match rig to antenna.

Performance Summary

No contacts were made. Did manage to hear two or three other stations but all attempts to reach them were unsuccessful. Wasn't able to determine how much power the other stations were running or the type of setup used. Also used the antenna as a receive only on 40m, this appears to have worked but without another outdoor antenna that could be switched in, no comparative measurements could be made.

Comments

Data for this case is inconclusive. Band conditions on 10m were very poor so there may not have been any stations there to begin with. Theorized that the concrete tiles could have been interfering with the radiation of energy from the antenna. The antenna has since been relocated outside the house under the eaves - see case 3.

Links to other ham related sites

[FCC Home page](#)

[FCC Downloadable forms](#) Includes form 610

[ARRL Home page](#)

[Near realtime MUF map](#) actual color map updated every 30 minutes

[AC6V Ham Radio DX Reference Guide](#) Tons of great links

[KB9JJA Ham Radio Links](#) another source of great links

[WE6W Home page](#) St Louis vertical information

[W6MMA upgrades to the St Louis vertical](#)

[Details on Slinky antennas](#)

[Want to save \\$\\$\\$ on your long distance phone bill?](#)

This page has been visited times.

[Back to Clif's telecom home page](#)

KE4UYP'S

Off Center fed Bent 10m YAGI for attics

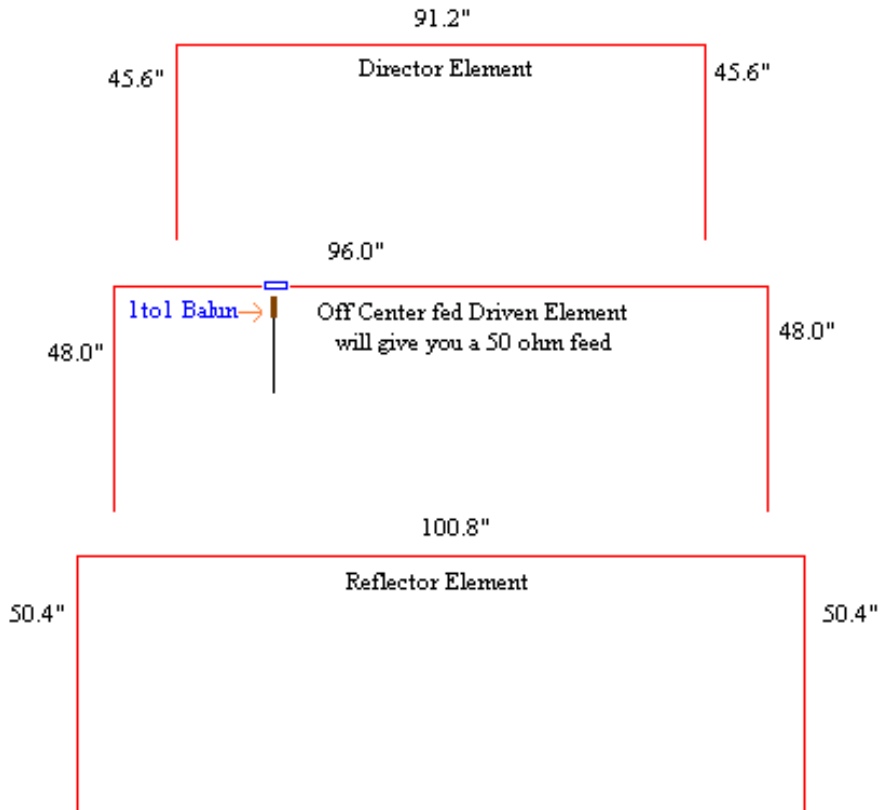

Specifications

This is a horizontally polarized three Element Yagi. The bent Elements cause very little performance lose.

When you consider it is only 8ft. 5" wide and 7ft. 6" long and still has 6.2dbi gain and 20db front to back ratio.

And when you off center feed it you get a perfect 50 ohm match to coaxial cables. The SWR is less than 2to1 for 600khz.

Not bad for a Antenna that the neighbors don't even know exist.

The question

HOW MANY INCHES FROM THE CENTER OF THE DRIVEN ELEMENT IS THE FEED POINT?

Is not a simple one, each installation is different there is no set distance from the center. There is too many variables to consider the height above ground is one of them the gauge wire is another all objects that are within 16 feet is one more but there is a simple solution to this problem. If you make each end of the driven element adjustable where you can easily change the length then you can easily off center the feedpoint to the exact spot that gives you the 50 ohm match.

Remember that you want to keep the total length of the driven element 16 feet long so if you shorten one side by one inch you want to lengthen the other side by one inch this will maintain the 16ft. if you make the last 12" of each end of the element where you have a second wire that is wrapped around the element wire and it is also 12" inches long you will be able to lengthen or shorten that wire easily.

So one-half of the driven element would be seven feet long and the other half of the driven element would be 8 feet long and you would be able to lengthen the seven foot element up to 12" inches longer and you would be able to lengthen the eight foot element up to 12 inches longer once you get your perfect match all you have to do then is solder the sliding wire permanently to the element on each end.

[Back to home page](#)



The Original WIREMAN

Your source for coax, connectors, wire, baluns,
and other *Certified Quality* WIREMAN products

[Who We Are](#) | [What's New](#) | [Products](#) | [Order](#)



Click for Specials!

The WireMan, Inc. ■ 261 Pittman Road ■ Landrum, SC 29356
(800) 727-WIRE Orders ■ 864.895.4195 ■ 864.895.5811 Fax



We now accept



Hosting, Web Development and Secure Services provided by [Cahaba Internet](#)



"Among the portable HF/VHF antennas I've seen to date, the Buddipole by W3FF Antennas is one of the classiest by far." - QST Magazine Review, July 2003 edition

New! Military-style [shock-corded whip antennas](#) now available!

Welcome to the home of the [Buddipole](#), an hf/vhf portable dipole antenna system which is designed to be modular, versatile, and efficient. You'll also find here many innovative new [Accessories](#) for hf/vhf portable antennas.

See over 35 independent Buddipole reviews [here](#).



> **The Buddipole Portable Antenna System**

Superior efficiency 40 through 2 meters.
Go anywhere. Do Anything.
Take the Buddipole with you.

Picture shown with optional rotator arms allowing for quick configuration changes in the field. Antenna can be configured in any position including sloper, L, V, inverted V, vertical, etc.



[Click here for more info](#)

> **Accessories**

A line of high quality and innovative new accessories for the Buddipole and other portable antennas including tripods, masts, stainless steel telescopic whips, etc.



[Click here for more info](#)

The Buddipole

Buddipole Package

The Mini Buddipole

The Buddistick

Accessories

FAQ's

Testimonials

Japanese Website

Shipping Info

About Us

Show Order

Info

Privacy Policy

Search

Index



[Click to subscribe to the Buddipole User's Group \(B.U.G\)](#)

Sign up for the **FREE Buddipole Email Newsletter!**

Email:

[Send Page To a Friend](#)



W3FF Antennas . 2390 Templeton Drive . Redding, CA 96002
USA

P: 530.226.8446 / F: 530.232.2753

[Privacy Policy](#) . [Info](#)

Y! SHOPPING



W3FF Antennas is a manufacturer of a lightweight, versatile hf portable dipole antenna system for amateur radio. This hf antenna is instantly configurable as a vertical dipole or any one of several other shapes including a vee dipole, sloper, or L. The Buddipole dipole antenna is directional and can be converted to a an effective single element vertical antenna (the "Buddistick") by using either one of the dipole antenna arms and a counterpoise. The Buddipole or Buddistick are perfect for space-restricted covenants such as use as an apartment antenna, hotel antenna or backup marine antenna, or as a compact dxpedition antenna or backpack antenna.

All world rights reserved W3FF Antennas, 2003.
Unauthorized duplication is unlawful.



Barker & Williamson

Producing the
Highest Quality
Radio Parts
Since 1932

 your basket

Antennas, Coils and Accessories for HF Radio



Home

What's New?

Web Specials

Product Catalog

Coil Catalog

Instruction Sheets

FAQ's

User Opinions

Ordering

Contact Us

U S Dealers

World Dealers

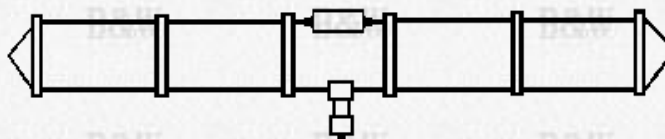

[Click Here for our Antenna Review in Popular Communications](#)

Broadband Antennas - Our field proven broadband HF antennas operate all frequencies continuously from 1.8 to 30 Mhz without an antenna tuner, plus 6 meters. If you are participating in various programs such as MARS, ARES, RACES or CAP these antennas will work all of your frequencies all the time. If your frequencies get reassigned, it does not matter.



Of course, these antennas are not limited to emergency operation. Any radio amateur enthusiast can take advantage of full coverage with one antenna that has a fairly small visual impact. We even have a configuration that can have the ends run down to the ground - *pretty stealthy!*

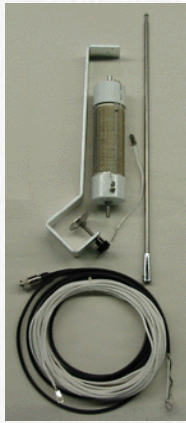

Other Antennas - Our AP-10A window/portable antenna lets almost anybody get on the air regardless of covenant restrictions, and is truly portable. For travel it easily fits in a suitcase or briefcase.

Components and Accessories -

Professional and amateur users alike can make use of various products we carry such as our world famous air wound coils, chokes, insulators, wire, cables - just look around the web site for all of your needs.



Copyright © 1997 - 2004 Barker & Williamson - All rights reserved

Antenna restrictions? - Short on Space?

The CliffDweller II Antenna

The CliffDweller II antenna!

The CliffDweller II is the Original variable length HF antenna that adjusts it's size to fit YOUR operating environment. 6 to 80 Mtrs. - QRP to 100 Watts -

Although composed of a full **130 feet** of wire (a full half wavelength on 80 mtrs!), the CliffDweller II will operate from a compressed length of only **15 feet** to a fully extended length of **50 feet** -- or anywhere in between. It fits the space you have available!

Fully compressed the CliffDweller II takes up less than one foot of space. Take it with you anywhere an antenna may be needed! Permanent or portable operation...



CliffDweller II - \$39.95 plus \$10.95 S&H (U.S. only) - *\$2.00 Insurance.
*Not responsible for lost or damaged packages - Please insure your purchase.
(Foreign orders please write for International shipping rates)

See main USA 2Way page for ordering information.

***30 Day Satisfaction Return requires antenna to be in resaleable condition.**

*When using this (or any antenna) indoors for transmitting purposes please use low power and keep the radiating elements as far as possible from humans and animals. RF energy can be harmful.



5401



[Back to USA 2Way Home Page](#)



~ ~ ~ The original CliffDweller ~ ~ ~

For best multi-band results an antenna tuner is recommended - Items may vary slightly in appearance or construction.



The BEST Antenna Guarantee in the industry!

The CliffDweller II comes our **exclusive *30 Day SATISFACTION Guarantee.** If it doesn't work in your environment - send it back! We'll issue a refund (minus s&h) in your original method of payment.

This is a secondary site - please visit us at www.usa2way.com

This is a secondary site - please visit www.usa2way.com for up to date information - Thanks!

[get your own web site!](#)
[try it FREE for 30 days](#)

this site built with
homestead
your web site company



Par Electronics
End-Fedz
Wire Antennas

← back

Amateur Wire Antennas



The **Par End-Fedz** are a full length half wave dipoles, but with an important difference. The coax connector is at one end of the dipole, where it is most needed. These antennas can be mounted horizontally, vertically or as a sloper. No ground plane or counterpoise is needed. Portable operation could not be easier. Simply hang the far end from a tree limb -- the coax is at the bottom. Hang it up in a hotel window or string it up in the attic. End insulators are supplied making suspension easy.

The UV resistant ABS plastic housing encloses an efficient matching network allowing the antenna to be fed with common 50 ohm coaxial cable. All hardware is stainless and the SO-239 connector is silver/teflon. The radiator material is a tough polyethylene jacketed, highly flexible #14 copper wire (41 strands of #30 gauge). One end comes with a #10 solder lug making attachment to the matchbox simple and allowing the radiator portion to be replaced if ever necessary. Power rating is a conservative 200 watts (except [EF-20/40](#)). Lightweight (the 20 meter version is only 0.5 pounds), they are ideal for portable work. The all black construction makes them difficult to see. Click here to see an [alternate view](#).

| Model | Band | Length | 1.5:1 BW | Order # | Your Price | Order |
|-----------------|--------------|-----------|-----------------------------|---------|----------------|-----------------------|
| EF-30 | 30 Meters | T.B.A. | T.B.A. | #2836 | T.B.A. | |
| EF-20 | 20 Meters | 33.0 Feet | 300 kHz | #4456 | \$41.95 | Order |
| EF-17 | 17 Meters | 28.0 Feet | 350 kHz | #4457 | \$41.95 | Order |
| EF-15 | 15 Meters | 22.0 Feet | 400 kHz | #4458 | \$41.95 | Order |
| EF-12 | 12 Meters | 17.5 Feet | 500 kHz | #4459 | \$40.95 | Order |
| EF-10 | 10 Meters | 16.5 Feet | 600 kHz | #4460 | \$39.95 | Order |
| EF- 6 | 6 Meters | 9.2 Feet | 1200 kHz | #4461 | \$38.95 | Order |
| EF-20/40 | 20/40 Meters | 39.0 Feet | Information | #2831 | \$57.95 | Order |

Send e-mail to dx@universal-radio.com
Copyright 2001-2004, [Universal Radio, Inc.](#)

[Click Here for the Cable Pulling Page](#)

Products

▶ [Ordering Information](#)

▶ [EZ Hang™](#)

▶ [EZ Hang™ Kit](#)

EZ Hang™, weights and EZ Winder

▶ [New Products](#)

▶ [Replacement Parts](#)

EZ Hang™ Information

▶ Phone: 540-286-0176

▶ E-mail us by [clicking here.](#)

▶ Order an EZ Hang™ using your [Credit Card](#)

▶ Order an EZ Hang™, two extra weights and a spare set of replacement bands by [check or money order](#) (in the U.S.) send **\$89.95** plus **\$8.05** shipping & handling to:

E-Z Hang
607A Jeff Davis Hwy
Suite #101
Code WP
Fredericksburg, VA
22401

▶ VA residents please add 4.5% sales tax.

▶ Your order will be shipped out the next business day via USPS Priority Mail.

▶ [Foreign check/ money orders](#)

Related Ham Information

▶ [Dealers and Links](#)

▶ [Upcoming Hamfests](#)

▶ [Unsolicited Testimonials](#)

▶ [Online Hamfest Classified/Auctions](#)

E Z H A N G

HANG YOUR NEXT WIRE ANTENNA

THE *EZ HANG™* WAY

US Patent No. 6,286,495

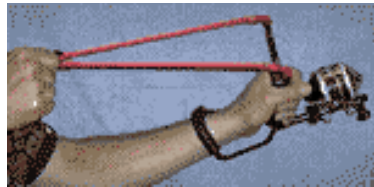

E-Z HANG
Get over trees & objects 100+ feet tall!



- ▶ **No climbing trees or ladders**
- ▶ **No dangerous bow-and-arrow**
- ▶ **No tangled string**

The perfect tool when you want to put up a wire antenna easily, quickly and safely.



EZ HANG™ can be used to "shoot" a line over a tree or other object over 100 feet high.

Tree surgeons and gardeners can use **EZ HANG™** to attach a line to a tree and pull it safely away from a structure in order to cut off branches.

Cable pullers can use **EZ HANG™** to "shoot" a drag-line through a dropped-ceiling/plenum up to 60 feet and avoid using long pull-rods. It cuts installation time and your costs dramatically. [Click Here for the Cable Pulling Page.](#)

Remember! SAFETY FIRST! The EZ HANG™ propels a high velocity projectile. Always use safety glasses or safety goggles when using the EZ HANG™. Be sure the area is cleared of personnel before using.



EZ HANG's™ basic construction is steel attached to a reel that is corrosion-resistant plastic and stainless steel. The reel comes with 300 feet of 10-pound-test monofilament line installed, a quick-disconnect clip to release the weight and an easy-to-see "bright yellow" one-ounce lead weight.

Don't be fooled by "rip-off" imitations that use inferior materials and a poor design!

Look for the EZ HANG™ name.

E-MAIL US BY [CLICKING HERE.](#)

[Click here to read our "Policy and Privacy Statement"](#)

Since 10-Jul-1999, this is the number of times this page has been viewed:



This webpage was last revised on 14-Jun-2004.

[RETURN to TOP](#)

Commercial

Homeland Security

Are you and your city ready?

Cost effective aluminum towers and tower-trailers for portable, mobile, minimal visual impact: site-testing, city back-up communications, emergency, surveillance, ENG

Low Profile Towers & Trailers

Quick Deploy Masts (see below photos)

Wide Band 155-174 MHz Vertical Antenna (see photo below)



Amateur

Performance is why we are #1. Antennas for 160 mtrs through 70cm. Verticals, Yagis, Towers, CC&R Friendly, Flagpoles & Flagpole Antennas

Antennas & Towers

Force 12 is the leading edge.

Made in the U.S.A.

Office hours 8:00am-4:30pm Pacific Time - see below

Force 12 performance, look at 80 /75 mtr stations worked from N6BT with Sigma-280 Ultra at 50' (3/16/04 - including comments about QSO's with YA8G and EA8BH)

See us at the SW Division Convention Aug 27-29

Check out WA5VGI, now 104 cfmd on 160! (6/8/04)

NEW! Product info, PDF downloads & 2004 pricing

We brought you out of the dark ages of traps - stay tuned **NEW!** Tornado Tuning Drive

Quick Deploy masts & Flagpole 40 Mtr Base Coil

The Falcon - (project "J-6") 20-6 mtr 6 band rotary dipole

Flag Poles

Flag Pole Fundraisers

Flag Pole Antennas new items



XR-5: the hot 5-bander. In 1 year, Alan, N5PA worked 276 countries!



C-3SS named "Buster" by Alan, K6IPM: 268 countries worked & 240 confirmed in 1 year (April 2002 to 2003).



30' FT30-M above in 6' sections. No tools.

15' FT15-T tripod in 4' sections. Goes up in minutes. No tools.

Sigma-164 wide band 155-174 MHz vertical dipole antenna, fully assembled, strong, 99.9% efficient, handles 300 watts power.

C-31XR & the Mag 240N in 4 months, Pete, WIRM achieved WAZ & DXCC on 40, 20 & 15 running only 200 watts (99.9% CW).



*Team Vertical at Casita Villa located on
Discovery Bay, Jamaica*

*Team Vertical in the 2003
CQWW CW claims 3 more
world records: 160 QRP
(6Y0A, K2KW op), 80 LP
(6Y8A, N6BT op), 15 mtr LP
(6Y9A, WA6O op). This will
give Team Vertical all 6 QRP
world records and 2 LP world
records all current. OTH will
soon be available for others to
use. Read K2KW's write-up
about his Top Band work:
[K2KW/6Y0A](#)*

Contact Force 12, Inc. for information on:

Amateur and Commercial Antennas, Low Profile Towers & Powered Masts

Office Hours: 8:00AM - 4:30PM Pacific Time

1.800.248.1985 , 1.805.227.1680,

FAX 1.805.227.1684

Force 12, Inc.

P.O. Box 1349

Paso Robles, Ca 93447

NEW! [e-mail to: force12info@sbcglobal.net](mailto:force12info@sbcglobal.net) , or to: force12manager@sbcglobal.net (home office)

You are free to print all the information in this web site for your own use. (Updated 08/03/04 - Happy Birthday Traci - Dad.)

Photo "Sunrise Over the Etosha Pan" courtesy Charles Summers, Jr. W0YG. All rights reserved.

Copyright, Force 12, Inc., 2001, 2002, 2003, 2004



Lakeview Company

The Hamstick Folks



Made in USA

[Products](#)

[Catalog](#)

[Order](#)

[Feedback](#)



Lakeview Company

Antennas

MIKE SWASS, KJ6XE, President

**Worldwide supplier and manufacturer of
mobile
antennas and accessories by WD4BUM.**

We aim to help YOU be heard!

3620-9A Whitehall Rd., Anderson, SC 29626 USA

Telephone (864) 226-6990

Fax (864) 225-4565

**Telephone Hours: Monday - Friday 8 AM - 4:30 PM Local
Eastern Time**

Copyright 2000, Lakeview Co., Inc., Anderson, SC. All Rights Reserved



News Flash! We can now be reached on the Web at:
www.isotronantennas.com

Now Available! - AM Broadcast Band Antennas
[Click Here for More Information](#)

[What Our Customers Say....](#)

[Photos of Isotron Antenna Installations](#) | [73 Magazine Reviews](#) | [How Do the Isotrons Work So Well? Prices, Specifications, & Ordering](#) | [Download Isotron Manuals](#) | [Isotron Catalog Request Form](#)

The Isotron Antenna

- Solve Virtually Any Restricted Space Problem - 40 Meter Isotron only 22 inches x 16 inches x 15 inches!
- Easy, Quick, and Simple Installation
- Tunes & Performs Without Radials or Antenna Tuners
- Handles Up to 1000 Watts PEP
- Durable Construction, Can be Used in Extreme Weather Conditions
- Excellent For Portable Operation - Emergencies, RV's, Field Day,



Installation at WDOEJA
Multiple Isotrons on one mast!

- Motels, Etc.
- Multi-Band Operation on One Feedline with Back-to-Back Mounting & NO Loss of Performance>
 - Can be mounted in ANY Position Without Loss of Performance
 - Maritime Operation - Uncluttered Setup, with Stainless-Steel Fasteners & Not Dependent Upon Grounding for Performance
 - SO-239 Connector on All Models
 - One Year Warranty on Material & Workmanship

- For Technical Information & Help -
Bilal Company
137 Manchester Drive
Florissant, CO 80816
719-687-0650

FireTrust MailWasher Pro: Complete Inbox Protection.

Spam stops here.



This website is Hosted by:

[CorpraNet](#)

25213

Counter provided by

WEB
c o u n t e r TM

41165



Your Shopping Cart

You have 0 items in your shopping cart
totalling \$0.00.

[View Cart](#) [Checkout](#)

| | | | | | | | |
|--------------------------------|----------------------------------|-----------------------------------|--|--------------------------------|--------------------------------|-------------------------------------|--|
| Antenna Tuners | Antenna Products | Antenna Analyzers | Morse Code / CW Products | Power Supplies | SWR Wattmeters | Antenna Accessories | All Product Categories |
|--------------------------------|----------------------------------|-----------------------------------|--|--------------------------------|--------------------------------|-------------------------------------|--|

Search Our Site

- Site Menu**
- [Download PDF Catalog](#)
 - [Download Manuals](#)
 - [Product Reviews](#)
 - [Price List](#)
 - [Dealer Listing](#)
 - [Website/Company News](#)
 - [About MFJ](#)
 - [Customer Service Info](#)
 - [Contact Info](#)
 - [Request Print Catalog](#)
 - [Main Page](#)

MFJ

40/30/20/17/15/12/10/6/2 Meter Apartment Antenna



Click the thumbnail for a full-size picture.

Price: \$99.95

[Add to Shopping Cart](#)
[Download the MFJ-1622 Manual](#)

The MFJ-1622 Apartment Antenna covers 40 through 2 Meters, mounts outdoor to windows, balconies, railings, and works great indoors mounted to desks, tables, and bookshelves!

This Apartment Antenna lets you operate 40 through 10 Meters on HF and 6 and 2 Meters on VHF with a single antenna! Its universal mount/clamp lets you easily attach it to window frames, balconies, and railings. It also works great indoors mounted to a desk, table, or bookshelf. It's not a five element yagi, but you'll work your share of exciting DX!

The highly-efficient air wound 'bug catcher' loading coil and telescoping 5 1/2 foot radiator lets you really get out! The radiator collapses to 2 1/2 feet for easy storage and



MFJ-267 -- MFJ Dummy Load/Wattmeter Only **\$149.95!**

[Learn More](#) [Add To Cart](#)



MFJ-269 -- HF/VHF/UHF Antenna/SWR/RF Analyzer w/ LCD, Counter & Meters Only **\$359.95!**

[Learn More](#) [Add To Cart](#)



902 -- *tiny* Travel Tuner Only **\$79.95!**

[Learn More](#) [Add To Cart](#)

carrying.

It includes coax RF choke balun, coax feed line, counterpoise wire and safety rope. The operating frequency is adjusted by moving the 'wander lead' on the coil and adjusting the counterpoise for the best SWR.



MFJ-1662 --
6 Thru 40
Meters
Mobile
Screwdriver

Antenna

Only **\$129.95!**

[Learn
More](#)

[Add To
Cart](#)

[Contact Us](#) | [Terms of Service](#) | [Privacy Notice](#)
[About Us](#) | [View Shopping Cart](#) | [Checkout](#)
[Main Page](#)

All information, images, and documents on this website are the sole property of MFJ Enterprises, Inc. Any reuse or redistribution of the contents of this website are strictly forbidden without authorization from MFJ Enterprises, Inc.



Your Shopping Cart

You have 0 items in your shopping cart
totalling \$0.00.

[View Cart](#) [Checkout](#)

- [Antenna Tuners](#)
- [Antenna Products](#)
- [Antenna Analyzers](#)
- [Morse Code / CW Products](#)
- [Power Supplies](#)
- [SWR Wattmeters](#)
- [Antenna Accessories](#)
- [All Product Categories](#)

Search Our Site

| HF Dipole | HF Loop | HF Mobile | HF Portable | HF Vertical/Base | Screwdriver | VHF/UHF Mobile | VHF/UHF Portable/HT | VHF/UHF Vertical/Base | Whips | | |
|---|---------|--|-------------|---|-------------|---|---------------------|--|-------|---------------------------------|--|
| List All Alphabetically | | Browse by Antenna Length | | Browse by Band Coverage | | Browse by Base/Mount Type | | Browse by Connector Type | | Browse by Price | |

- Site Menu**
- [Download PDF Catalog](#)
 - [Download Manuals](#)
 - [Product Reviews](#)
 - [Price List](#)
 - [Dealer Listing](#)
 - [Website/Company](#)
 - [News](#)
 - [About MFJ](#)
 - [Customer Service Info](#)
 - [Contact Info](#)
 - [Request Print Catalog](#)
 - [Main Page](#)

Antenna Products by Product Listing

| Model # | Description | Price |
|--------------------------|---|---------------|
| MFJ-1952 | 4.5 Foot Extra-Long Telescopic Whip | 14.95 |
| MFJ-1662 | 6 Thru 40 Meters Mobile Screwdriver Antenna | 129.95 |
| MFJ-1661 | 6 Thru 40 Meters Portable Screwdriver Antenna | 119.95 |
| MFJ-1668 | 6 Thru 80 Meters Mobile Screwdriver Antenna | 159.95 |
| MFJ-1664 | 6 Thru 80 Meters Portable Screwdriver Antenna | 149.95 |
| MFJ-1954 | 10 Foot Extra-Long Telescopic Whip | 19.95 |
| MFJ-1956 | 12 Foot Extra-Long Telescopic Whip | 29.95 |
| MFJ-1964 | 72 Inch Mobile Whip w/ 3/8-24 Base | 19.95 |
| MFJ-1966 | 108 Inch Mobile Whip w/ 3/8-24 Base | 24.95 |

MFJ-1752
--
5/8

Wave Ground Plane 220 MHz Antenna
Only **\$24.95!**

[Learn More](#)

[Add To Cart](#)

MFJ-1798 --

80/40/30/20/17/15/12/10/6/2 Meters Vertical Antenna
Only **\$289.95!**

[Learn More](#)

[Add To Cart](#)



MFJ-1026 --
1.5-30
MHz
Deluxe
Noise Canceller
Only **\$179.95!**

[Learn More](#) [Add To Cart](#)



MFJ-1778 --
G5RV all
band HF
antenna
Only
\$39.95!

[Learn More](#) [Add To Cart](#)

[Contact Us](#) | [Terms of Service](#) | [Privacy Notice](#)
[About Us](#) | [View Shopping Cart](#) | [Checkout](#)
[Main Page](#)

All information, images, and documents on this website are the sole property of MFJ Enterprises, Inc. Any reuse or redistribution of the contents of this website are strictly forbidden without authorization from MFJ Enterprises, Inc.



Your Shopping Cart

You have 0 items in your shopping cart
totalling \$0.00.

[View Cart](#) [Checkout](#)

[Antenna Tuners](#)
 [Antenna Products](#)
 [Antenna Analyzers](#)
 [Morse Code / CW Products](#)
 [Power Supplies](#)
 [SWR Wattmeters](#)
 [Antenna Accessories](#)
 [All Product Categories](#)

Search Our Site

[List All](#)
[Alphabetically](#)

[Browse by](#)
[Price](#)

Site Menu

[Download PDF Catalog](#)
[Download Manuals](#)
[Product Reviews](#)
[Price List](#)
[Dealer Listing](#)
[Website/Company](#)
[News](#)
[About MFJ](#)
[Customer Service Info](#)
[Contact Info](#)
[Request Print Catalog](#)
[Main Page](#)

Hot New Products by Product Listing

| Model # | Description | Price |
|---------------------------|--|--------------|
| MFJ-5803 | 3 Foot Coax Patch Cable, RG-58A/U w/ 2 PL-259 Connectors | 5.95 |
| MFJ-5803H | 3 Foot Coax Patch Cable, RG-213A/U w/ 2 PL-259 Connectors | 10.95 |
| MFJ-5163 | 3.5mm to 3.5mm Cable w/ Extra 3.5mm Input | 8.95 |
| MFJ-1952 | 4.5 Foot Extra-Long Telescopic Whip | 14.95 |
| MFJ-911 | 4:1 Current Balun/Unun | 39.95 |
| MFJ-5806 | 6 Foot Coax Patch Cable, RG-58A/U w/ 2 PL-259 Connectors | 9.95 |
| MFJ-5806H | 6 Foot Coax Patch Cable, RG-213A/U w/ 2 PL-259 Connectors | 10.95 |
| MFJ-1706H | 6 POSITION BALANCED LINE ANTENNA SWITCH | 99.95 |
| MFJ-7700 | 6 Pack Standard Banana Plug Pairs | 5.95 |
| MFJ-16C06 | 6 Pack of Dog Bone Ceramic Glazed Center/End Insulators | 3.95 |
| MFJ-11C06 | 6 Pairs of Anderson PowerPole Connectors | 5.49 |
| MFJ-1700C | 6 Position HF Antenna Transceiver Switch w/ Lightning Arrestor | 99.95 |

MFJ-58100H -- 100 Foot Coax Patch Cable, RG-213A/U w/ 2 PL-259 Connectors
Only \$79.95!

[Learn More](#)

[Add To Cart](#)

MFJ-5806H -- 6 Foot Coax Patch Cable, RG-213A/U w/ 2 PL-259 Connectors
Only \$10.95!

[Learn More](#)

[Add To Cart](#)

MFJ-6404F -- Universal Foam Insert for MFJ-6404
Only \$9.95!

[Learn More](#)

[Add To Cart](#)

| | | |
|----------------------------|--|---------------|
| MFJ-1662 | 6 Thru 40 Meters Mobile Screwdriver Antenna | 129.95 |
| MFJ-1661 | 6 Thru 40 Meters Portable Screwdriver Antenna | 119.95 |
| MFJ-1668 | 6 Thru 80 Meters Mobile Screwdriver Antenna | 159.95 |
| MFJ-1664 | 6 Thru 80 Meters Portable Screwdriver Antenna | 149.95 |
| MFJ-5809 | 9 Foot Coax Patch Cable, RG-58A/U w/ 2 PL-259 Connectors | 11.95 |
| MFJ-11F20 | 10 Pack of Assorted ATO Fuses | 9.95 |
| MFJ-1438 | 10M/6M/2M/440 MHz Quad Band Mobile Antenna | 99.95 |
| MFJ-5812 | 12 Foot Coax Patch Cable, RG-58A/U w/ 2 PL-259 Connectors | 12.95 |
| MFJ-11C12 | 12 Pairs of Anderson PowerPole Connectors | 10.49 |
| MFJ-18G100 | 14 Gauge Copper Strand Antenna Wire - 100 ft | 11.95 |
| MFJ-18G250 | 14 Gauge Copper Strand Antenna Wire - 250 ft | 27.95 |
| MFJ-5818 | 18 Foot Coax Patch Cable, RG-58A/U w/ 2 PL-259 Connectors | 14.95 |
| MFJ-5818H | 18 Foot Coax Patch Cable, RG-213A/U w/ 2 PL-259 Connectors | 19.95 |
| MFJ-1742 | 20 Meter Extended Double Zepp Antenna | 79.95 |
| MFJ-11C25 | 25 Pairs of Anderson PowerPole Connectors | 19.95 |
| MFJ-1866 | 25-1300 MHz Discone Antenna | 39.95 |
| MFJ-1124 | 40 Amp Multiple DC Power Outlet Strip w/ 4 PowerPole Connectors & 2 Binding Post | 59.95 |
| MFJ-1129 | 40 Amp Multiple DC Power Outlet Strip w/ 7 PowerPole Connectors & 3 Binding Post | 109.95 |
| MFJ-1126 | 40 Amp Multiple DC Power Outlet Strip w/ 8 PowerPole Connectors | 79.95 |
| MFJ-1128 | 40 Amp Multiple DC Power Outlet Strip w/ 12 PowerPole Connectors | 99.95 |
| MFJ-1456 | 40 Thru 2 Meters HF Mobile Antenna | 149.95 |
| MFJ-17754 | 40/20 Meter Dipole Antenna | 59.95 |
| MFJ-5850 | 50 Foot Coax Patch Cable, RG-58A/U w/ PL-259 Connector & Open End | 24.95 |



MFJ-6404 -- Instrument Case w/ Universal Foam

Insert

Only **\$39.95!**

[Learn More](#)

[Add To Cart](#)

| | | |
|----------------------------|---|----------------|
| MFJ-5850H | 50 Foot Coax Patch Cable, RG-213A/U w/ 2 PL-259 Connectors | 49.95 |
| MFJ-1748 | 80 Meter End Fed Zepp Antenna | 69.95 |
| MFJ-974 | 80 Thru 6 Meters Balanced Line Antenna Tuner | 179.95 |
| MFJ-17758 | 80/40 Meter Dipole Antenna | 79.95 |
| MFJ-58100 | 100 Foot Coax Patch Cable, RG-58A/U w/ 2 PL-259 Connectors | 39.95 |
| MFJ-58100H | 100 Foot Coax Patch Cable, RG-213A/U w/ 2 PL-259 Connectors | 79.95 |
| MFJ-11C100 | 100 Pairs of Anderson PowerPole Connectors | 79.95 |
| MFJ-991 | 150 Watt <i>IntelliTuner</i> Automatic Antenna Tuner | 219.95 |
| MFJ-1777 | 160 Thru 6 Meter All Band Doublet Antenna | 49.95 |
| MFJ-974H | 160 Thru 6 Meters Balanced Line Antenna Tuner | 199.95 |
| MFJ-18T100 | 300 Ohm Twin Lead - 100 ft, 18 Gauge Standard | 24.95 |
| MFJ-18T250 | 300 Ohm Twin Lead - 250 ft, 18 Gauge Standard | 59.95 |
| MFJ-18T050 | 300 Ohm Twin Lead - 500 ft, 18 Gauge Standard | 12.95 |
| MFJ-913 | 300 Watt 4:1 Current Balun | 29.95 |
| MFJ-993 | 300 Watt <i>IntelliTuner</i> Automatic Antenna Tuner | 259.95 |
| MFJ-16D01 | 450 Ohm Center Insulator | 6.95 |
| MFJ-18H050 | 450 Ohm Ladder Line - 50 ft, 10 Gauge Solid | 8.95 |
| MFJ-18H100 | 450 Ohm Ladder Line - 100 ft, 10 Gauge Solid | 14.95 |
| MFJ-18H250 | 450 Ohm Ladder Line - 250 ft, 10 Gauge Solid | 34.95 |
| MFJ-58500H | 500 Foot Coax Patch Cable, RG-213A/U w/ 2 PL-259 Connectors | 5000.00 |
| MFJ-994 | 600 Watt <i>IntelliTuner</i> Automatic Antenna Tuner | 359.95 |
| MFJ-919 | 1500 Watt 4:1 Current Balun | 59.95 |
| MFJ-902 | <i>tiny</i> Travel Tuner | 79.95 |
| MFJ-902H | <i>tiny</i> Travel Tuner w/ Balun | 99.95 |
| MFJ-904 | <i>tiny</i> Travel Tuner w/ SWR/Wattmeter | 109.95 |
| MFJ-904H | <i>tiny</i> Travel Tuner w/ SWR/Wattmeter & Balun | 129.95 |

| | | |
|----------------------------|---|--------------|
| MFJ-7602 | Anderson PowerPole Connector Crimping Tool | 9.95 |
| MFJ-1703 | Antenna/Transmitter RF Safety Switch | 19.95 |
| MFJ-7704 | BNC to Dual Banana Adaptor | 5.95 |
| MFJ-5510 | Cigarette Lighter Adapter | 6.95 |
| MFJ-18D120 | Dacron Wire Rope - 120 ft, 3/32 | 29.95 |
| MFJ-288R | Deluxe Headset Mic for Yaesu VX-7R | 24.95 |
| MFJ-1922 | Digital Screwdriver Antenna Controller | 79.95 |
| MFJ-283I | Ear-Vibration Speaker/Mic for ICOM & Compatibles | 39.95 |
| MFJ-283K | Ear-Vibration Speaker/Mic for Kenwood & Compatibles | 39.95 |
| MFJ-283Y | Ear-Vibration Speaker/Mic for Yaesu & Compatibles | 39.95 |
| MFJ-292R | Featherweight Earphone / Microphone for Yaesu VX-7R | 19.95 |
| MFJ-16C01 | Glazed Ceramic Antenna Insulator | 0.69 |
| MFJ-390 | GooseNeck Desktop Mic Stand | 14.95 |
| MFJ-5535M | HF DC Power Cable - HF to Anderson PowerPole | 19.95 |
| MFJ-916BN | HF to 440 MHz Duplexer w/ Female N Connectors | 29.95 |
| MFJ-916B | HF to 440 MHz Duplexer w/ SO-239 Connectors | 29.95 |
| MFJ-1919 | Heavy Duty Portable Antenna Tripod | 79.95 |
| MFJ-7709 | Hi-Current Dual Banana Plug | 5.95 |
| MFJ-5393MI | ICOM Modular Adapter Cable for MFJ-394/396 | 19.95 |
| MFJ-6404 | Instrument Case w/ Universal Foam Insert | 39.95 |
| MFJ-5393MK | Kenwood Modular Adapter Cable for MFJ-394/396 | 19.95 |
| MFJ-8710 | Micro Color Camera | 59.95 |
| MFJ-1261 | Microphone Control Center - 1 Mic in to 2 Rigs Out | 89.95 |
| MFJ-1260 | Microphone Control Center - 2 Mics In to 1 Rig Out | 79.95 |
| MFJ-1263 | Microphone Control Center - 2 Mics In to 2 Rigs Out | 99.95 |
| MFJ-295R | Mini Speaker / Microphone for Yaesu VX-7R | 19.95 |
| MFJ-1401 | Mobile to Base Station Ground Plane Kit | 19.95 |
| MFJ-1709 | PTT Operator Foot Switch | 21.95 |

| | | |
|----------------------------|---|--------------|
| MFJ-393MI | Professional Grade Boom Mic Headphones - ICOM Radios w/ 8-Pin Modular Plug | 59.95 |
| MFJ-393MK | Professional Grade Boom Mic Headphones - Kenwood Radios w/ 8-Pin Modular Plug | 59.95 |
| MFJ-393MY | Professional Grade Boom Mic Headphones - Yaesu Radios w/ 8-Pin Modular Plug | 59.95 |
| MFJ-5429 | RS-232 to USB Adapter Cable | 24.95 |
| MFJ-993RC | Remote Control for MFJ-991/MFJ-993/MFJ-994 | 39.95 |
| MFJ-293R | Rubber Flex Earloop Bud / Microphone for Yaesu VX-7R | 24.95 |
| MFJ-1706 | Six Position Balanced Line Antenna Switch w/ 5-way Binding Posts | 89.95 |
| MFJ-5427 | USB to Parallel Cable (25 pin female) | 24.95 |
| MFJ-5428 | USB to Parallel Cable (Centronics) | 24.95 |
| MFJ-1964K | Ultimate Portable HF Vertical Antenna Kit | 53.80 |
| MFJ-6404F | Universal Foam Insert for MFJ-6404 | 9.95 |
| MFJ-5512M | VHF DC Power Cable - VHF to Anderson PowerPole | 17.95 |
| MFJ-5393MY | Yaesu Modular Adapter Cable for MFJ-394/396 | 19.95 |

[Contact Us](#) | [Terms of Service](#) | [Privacy Notice](#)
[About Us](#) | [View Shopping Cart](#) | [Checkout](#)
[Main Page](#)

All information, images, and documents on this website are the sole property of MFJ Enterprises, Inc. Any reuse or redistribution of the contents of this website are strictly forbidden without authorization from MFJ Enterprises, Inc.



Today's Date is
September
6



: [Distributors](#) : [News](#) : [Contact](#) : [Site Map](#) : [Order](#) : [Prices](#) : [Products](#) : [Home](#) :
: [Transceivers](#) : [GPS](#) : [Fishfinders](#) : [Plotters](#) : [Antennas](#) :

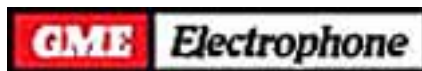

Satelite Phones now available

Revised 2001 undefined NaN,



©2001 Copyright ,Terlin OUTbacker A.C.N. 009 028 853. 1999,.
Users of this Web site are deemed to have read and accepted the conditions
described in the [Copyrigt / Disclaimer](#) declaration.

Prices and Specifications subject to change without notice.

Web Site designed by [WOODWORKS Multimedia](#) and is maintained by "OUTbacker."

[Home](#) • [MinuteMan™ Portable HF Antennas](#) • [Sidekick Mobile HF Antenna](#) •
[QuickStick™ HF Antennas](#)
[Dipoles, Antenna Wire, Rope, and Parts](#) • [VHF/UHF Antennas and Accessories](#)
• [Connectors, Adapters, and Coax Cable](#) • [Mounts](#) • [Tools](#)
[DC Power Accessories](#) • [PackMules™ Portable DC Power Packs](#) • [PowerPals™ DC](#)
[Cables](#)

[Alphabetical Index of Products](#)

[Hamfest Schedule](#)

Quicksilver Radio Products

(Almost) Everything But The Rig

F Note! We now accept PayPal online payments

NEW! Take a look at our
[VHF & UHF Antennas and Accessories](#)

&

[Tools and 12 Volt Accessories](#)

MinuteMan 20™ Portable Antennas get you on the air from wherever you are



A complete HF Station in a Briefcase.



From the Park



From the Backyard



From the Mountaintop

The MinuteMan 20 is, we believe, the best performing portable antenna of its type on the market today. It operates on 20-17-15-12-10 Meters without a tuner (in most cases). On 15, 12, and 10 Meters it's a full 1/4-wavelength long. For 20 and 17 Meters, a small bit of High Efficiency loading coil is added. For more information on why efficiency is so important, and why our antenna is better, go to [those pesky laws of physics](#)

It fits in any standard briefcase, backpack or airplane carry-on. We designed it to be rugged, lightweight (about 5 lbs.) and field serviceable. It's perfect any time you need a quick set-up antenna.

Why it's better:

- Sets up in 3 minutes or less, with no tools and no supports needed
- Outperforms competitive antennas
- Fits in a briefcase, backpack, carry-on bag, etc.
- Less expensive, and no "extras" needed to purchase

Specifications:

Height: (when fully extended) appx 12'10"

Power: 100 Watts

Weight: appx 5 lbs

Radials: 4 radials included, each 16'8" long

Longest piece: (when disassembled) 17"

Base Size: (when assembled, base is included) 3' x 3'

Electrical Description:

The MinuteMan 20 is a classic 1/4 Wave vertical groundplane antenna on 10-12-15 Meters. A lower element of #14 wire attaches to a 6' telescoping whip. The whip length is adjusted for best SWR match. For 17 and 20 Meters, a small loading coil is inserted between the elements. The coil is oversquare -- that is, larger in diameter than in length. This Hi-Q design provides much lower loss than the long skinny coils that others use.

Four counterpoise radials are included. Each consists of two conductors, one 8'4", the other 16'8". These lengths are approximately 1/4 wavelength on 10 and 20 Meters. This arrangement strikes an ideal balance between portability and ease of use on one hand, and high earth loss on the other.

To download a printable PDF file of the manual, [click here](#).

Pricing

We sell the MinuteMan 20™ for \$130, plus \$12 shipping and handling. We now accept PayPal.

You may find it more convenient to purchase through one of our authorized dealers. Each dealer sets his or her own retail price and shipping charge.

Amateur Accessories, Champaign, Illinois www.amateuraccessories.com

Associated Radio, Overland Park, Kansas www.associatedradio.com

Austin Amateur Radio, Austin, Texas www.aaradio.com

ComDaC, St. Joseph, Michigan www.comdac.com

GigaParts, Huntsville, Alabama www.gigaparts.com

KJI Electronics, Caldwell, New Jersey www.kjielelectronics.com

Lentini Communications, Newington, Connecticut www.lentinicomm.com

R & L Electronics, HAMilton, Ohio www.randl.com

Radio City, Mounds View, Minnesota www.radioinc.com

Universal Radio, Reynoldsburg, Ohio www.universal-radio.com

W4RT Electronics, Huntsville Alabama www.w4rt.com

To order:

We now accept PayPal on-line payments. Your personal check is also welcome. Our mailing address is:

**Quicksilver Radio Products
30 Tremont St.
Meriden, CT 06450**

If you're ordering by mail, please include a list of what you are ordering, your shipping address, and telephone and/or e-mail address. We generally ship within 1 or 2 business days after receiving your order.

Shipping & Handling:

| Order Total | Shipping |
|----------------------------|-----------------|
| \$.01 - \$9.99 | \$5 |
| \$10.00 - \$49.99 | \$7 |
| \$50.00 - \$99.99 | \$9 |
| \$100.00 - \$200.00 | \$12 |
| Over \$200 | \$15 |

Need more info? E-mail info@qsradio.com.

**Thanks and 73,
John Bee, N1GNV**

Send mail to webmaster@qsradio.com with questions or comments about this web site.

Copyright © 2002 Quicksilver Radio Products

Last modified: 05/19/04

Antennas

Accessories

Latest News

Message Board

How to Order

Contact Me

Home Page

 View Cart

144298

Hi-Q-Antennas™ by **W6HIQ**
VE7BOC / HA5CMG

Special Announcement!

Visalia, Dayton and SeaSide Ham Conventions are over and thanks to those customers who took time out to see us and to buy a Hi-Q-Antenna or to order one for later delivery. Our back log is more manageable than last year since we have ramped up our production for the Ham versions and have separated the Military types in production.

We INTENDED to EAT the competitors' LUNCH and NOW we will eat their DINNER as well! Not just by the QUALITY and PERFORMANCE, but by PRICE as well! Please visit our website (and theirs) and COMPARE! ASK them for the RADIATION EFFICIENCY and other technical details that pertain to an HF Mobile antenna, and see what kind of answers you get. Ask if they have Hewlett Packard antenna test equipment to verify radiation Field Strength... ask about the COIL "Q"... and ask if they have US or Foreign PATENTS. As our motto says: Shop around and compare, BUT hold on your wallet until you get to the Hi-Q-Antenna products.

My very 73 to you all,
Charlie Gyenes, W6HIQ (HA5CMG)

Welcome to the Hi-Q-Antennas™ Home Page!

The Hi-Q- Antennas Mission Statement:

**Force the competitors
to produce a better
quality and better
performing antenna by
LEADING the WAY!**

The new, improved, Hi-Q-Antennas™ by W6HIQ / VE7BOC / HA5CMG are the latest, state-of-the-art, 6th generation, stealth design. Hi-Q, Hi-Radiation efficiency is provided by computer design and Mil-Spec materials used in manufacturing.

Remember, the Hi-Q-Antennas design is NOT a cheap copy of the original Don Johnson screwdriver antenna. These Hi-Q-

Antennas™ products are the **Highest Radiation Efficient** and **Best Quality** HF Mobile antenna EVER designed and manufactured, and are covered by one or more of the following patents: US 6,275.195 B1 and US 6,496.154 B2. For a more in-depth comparison between the Hi-Q-Antennas design and screwdriver-type designs, [click here](#).

Please use the links to the left to learn more about my [ANTENNAS](#) and [ACCESSORIES](#). Also, be sure to check the [LATEST NEWS](#) page for new product announcements, hamfest schedules, etc. You may also wish to visit our [MESSAGE BOARD](#) to ask questions and get advice from other owners of Hi-Q-Antennas products. When you've decided on the right antenna for you, utilize the Secure [SHOPPING CART](#) to place your order.

If you have any questions, please don't hesitate to [contact me](#). You may also get answers to many common questions by reading the [Hi-Q-Antennas™ INSTALLATION MANUAL](#) and by visiting the [ARRL Automotive RFI web site](#).

73 - Charlie Gyenes
W6HIQ / VE7BOC / HA5CMG



Copyright 2003, All Rights Reserved. "Hi-Q-Antennas" is the registered Trademark of Charles M. Gyenes

Web Site Design and Hosting by QTH.COM

[GLA HOME](#)

TEXAS
BUGCATCHER
[ANTENNAS](#)

Texas Twister
[Click for Drawing](#)

DEALER
[Bencher](#)

Paddle DustCover
Refill Kits

info@texasbugcatcher.com
[E-MAIL](#) | [ORDER](#)

Rev.2.5.4 8-2-2004

*The report of my illness grew out of his illness,
the report of my death was an exaggeration.*

Mark Twain

*Folks, I'm alive... kicking...
and building Texas BugCatcher!*

Henry Allen, K5BUG

A Wonderful Day!

Henry and Tina

to you

Our Friends and Fellow Hams

Now offering you SECURE ordering thru Cahaba Internet!

[e.mail](mailto:info@texasbugcatcher.com) info@texasbugcatcher.com

VISA, MasterCard, Discover, and American Express accepted

[HOME PAGE](#) | [BUGCATCHER](#) | [BENCHER COVER](#) | [GLA ANTENNAS](#)

GLA - texasbugcatcher Web Site by V I S . . .
© 1998-99, Van Iderstine & Sons, LLC, All Rights Reserved

BugCatcher

BugCatcher

*Texas
BugCatcher*

*Texas
BugCatcher*

*Texas
BugCatcher*

*Texas
BugCatcher*

*Texas
BugCatcher*

*Texas
BugCatcher*

Amateur Radio Ventennas

Specifications

| Model | Frequency (MHz) | Gain (dBi) | Length | Feedline | Price |
|---------------|-------------------|--------------|--------|-------------|----------|
| VT-14 | 144 - 148 | 2.6 | 36 in. | 3 ft. RG-58 | \$54.95 |
| VT-22 | 222 - 225 | 2.6 | 19 in. | 3 ft. RG-58 | \$54.95 |
| VT-44 | 440 - 450 | 2.6 | 16 in. | 3 ft. RG-58 | \$54.95 |
| VT-27 | 144-148 & 440-450 | 2.6 | 36 in. | 3 ft. RG-58 | \$84.95 |
| VT-90 | 900 - 928 | 4.2 | 19 in. | 3 ft. RG-58 | \$84.95 |
| VT-12 | 1270 - 1290 | 4.2 | 19 in. | 3 ft. RG-58 | \$84.95 |
| VT-15S | 140-172 & 440-512 | Receive only | 36 in. | 3 ft. RG-58 | \$54.95 |
| VT-SWL | 2 - 30 | Receive only | 36 in. | 3 ft. RG-58 | \$129.95 |

Note: all feedlines terminated with an SO-239 connector.

The Ventenna is constructed from rugged ABS plastic tubing. As such, it is virtually indestructible. It is designed to fit over vent pipe sizes from 1 to 3 inches, and works over metal or plastic vent pipes. The Ventenna is hollow, thus it does not disrupt the vent function in any way.

The normal "ABS Black" color of the outside of the Ventenna may be painted with any non-metallic-based paint. This allows you to match the Ventenna to the other fixtures on the rooftop.

[Question?](#)

[Return Home](#)

Click on the links below to learn more about the *HFP*.



- [Antenna Construction](#)
- [Antenna Specs](#)
- [HP Network Analyzer Results](#)
- [View User's Guide \(pdf\)](#)
- [View 80m Coil Guide \(pdf\)](#)
- [Purchase an](#)
HFP

HFp Spares Price List



- [Welcome](#)
- [Order Form](#)
- [About Us](#)

Welcome

Super Antennas

Superior Ham Radio Antennas by W6MMA

Dealers Welcome!

Check out our products:

[MP-1](#)

[MP-2](#)

[MP-3](#)

[21' Mast](#)

[Drive-on Mount](#)

[Accessories](#)

[Yagi](#)

[Order Online now!](#)

[Click Here](#)

NEW

The Only Automatic Computerized
Screwdriver Tuner/Controller In the World! The
SDC 120



[Check out the new price on
our Yagi System!](#)



Super Antennas by
W6MMA

1-530-622-6668/1-530-622-2390
1606 Pheasant Way
Placerville, CA 95667

w6mma@superantennas.com



We Accept



[Report Site Problems
here](#)

Site Design By:
[QBKID.COM](#) © 2003

[TheCounter.com](#)
VISITOR 43258



NEW

[Portable Dipole system](#)



Stealth Base Station Antennas

Restrictive covenants or ordinances got you off the air?
Want to put up a very effective antenna that even the XYL
will like?

The ultimate in STEALTH! This very efficient disguised
antenna looks like (and is) a fully functional WEATHER
VANE. The deception is so totally effective that anyone
looking for your antenna will have trouble finding it. It is
so attractive that the neighbors will want one!

Specifications and performance are the same as the GIA-
XXX series antennas. With its great performance and
effective disguise, this is the best clandestine antenna
available.

Just in case the neighbors want a Weather Vane like yours,
there is a special model just for them. It looks exactly like
the STEALTHY antenna but is only a weather vane.



| Model | Band | Elements | Price | S & H |
|-----------|------------------|----------|---------|--------|
| WVA-146-2 | 144-148 MHz | 1 | \$59.95 | \$5.00 |
| WVA-223-2 | 222-225 MHz | 1 | \$59.95 | \$5.00 |
| WVA-445-4 | 440-450 MHz | 2 | \$69.95 | \$5.00 |
| WVA-NV | Neighbor Version | | \$29.95 | \$5.00 |

Prices are in U.S. Dollars. Foreign orders add \$10.00 S & H.

Don Stoner, W6TNS, has an interesting [dissertation](#)
on the need for hidden antennas on his web site.

009869



Your Shopping Cart

You have 0 items in your shopping cart
totalling \$0.00.

[View Cart](#) [Checkout](#)

| | | | | | | | |
|--------------------------------|----------------------------------|-----------------------------------|--|--------------------------------|--------------------------------|-------------------------------------|--|
| Antenna Tuners | Antenna Products | Antenna Analyzers | Morse Code / CW Products | Power Supplies | SWR Wattmeters | Antenna Accessories | All Product Categories |
|--------------------------------|----------------------------------|-----------------------------------|--|--------------------------------|--------------------------------|-------------------------------------|--|

Search Our Site

Site Menu

- [Download PDF Catalog](#)
- [Download Manuals](#)
- [Product Reviews](#)
- [Price List](#)
- [Dealer Listing](#)
- [Website/Company News](#)
- [About MFJ](#)
- [Customer Service Info](#)
- [Contact Info](#)
- [Request Print Catalog](#)
- [Main Page](#)

"Easy Up Antennas"



Click the thumbnail for a full-size picture.

Price: \$16.95

[Add to Shopping Cart](#)

Practical antenna book for hams and SWL. Tells how to build and put up inexpensive fully tested wire antennas, including beams. Ed Noll, W3FQJ

949E -- 300 Watt Antenna Tuner
Only **\$149.95!**

[Learn More](#)
[Add To Cart](#)

MFJ-1662 -- 6 Thru 40 Meters Mobile Screwdriver Antenna
Only **\$129.95!**

[Learn More](#)
[Add To Cart](#)

MFJ-267 -- MFJ Dummy Load/Wattmeter
Only **\$149.95!**

[Learn More](#)
[Add To Cart](#)



MFJ-993
-- 300

Watt *IntelliTuner*
Automatic Antenna Tuner
Only **\$259.95!**

Learn
More

Add To
Cart

[Contact Us](#) | [Terms of Service](#) | [Privacy Notice](#)
[About Us](#) | [View Shopping Cart](#) | [Checkout](#)
[Main Page](#)

All information, images, and documents on this website are the sole property of MFJ Enterprises, Inc. Any reuse or redistribution of the contents of this website are strictly forbidden without authorization from MFJ Enterprises, Inc.



Your Shopping Cart

You have 0 items in your shopping cart
totalling \$0.00.

[View Cart](#) [Checkout](#)

| | | | | | | | |
|--------------------------------|----------------------------------|-----------------------------------|--|--------------------------------|--------------------------------|-------------------------------------|--|
| Antenna Tuners | Antenna Products | Antenna Analyzers | Morse Code / CW Products | Power Supplies | SWR Wattmeters | Antenna Accessories | All Product Categories |
|--------------------------------|----------------------------------|-----------------------------------|--|--------------------------------|--------------------------------|-------------------------------------|--|

Search Our Site

- Site Menu**
- [Download PDF Catalog](#)
 - [Download Manuals](#)
 - [Product Reviews](#)
 - [Price List](#)
 - [Dealer Listing](#)
 - [Website/Company News](#)
 - [About MFJ](#)
 - [Customer Service Info](#)
 - [Contact Info](#)
 - [Request Print Catalog](#)
 - [Main Page](#)

"73 Dipole Vertical Antennas"

Picture
Coming
Soon

Price: \$12.95

[Add to Shopping Cart](#)

Ed Noll, W3FQJ gives you several 73 antenna projects constructed with a minimum of tools and equipment. All you need is desire to build.



MFJ-902 -- *tiny* Travel Tuner
Only **\$79.95!**

[Learn More](#)
[Add To Cart](#)



MFJ-267 -- MFJ Dummy Load/Wattmeter
Only **\$149.95!**

[Learn More](#)
[Add To Cart](#)



MFJ-1662 -- 6 Thru 40 Meters Mobile Screwdriver Antenna
Only **\$129.95!**

[Learn More](#)
[Add To Cart](#)



MFJ-993
-- 300

Watt *IntelliTuner*
Automatic Antenna Tuner
Only **\$259.95!**

Learn
More

Add To
Cart

[Contact Us](#) | [Terms of Service](#) | [Privacy Notice](#)
[About Us](#) | [View Shopping Cart](#) | [Checkout](#)
[Main Page](#)

All information, images, and documents on this website are the sole property of MFJ Enterprises, Inc. Any reuse or redistribution of the contents of this website are strictly forbidden without authorization from MFJ Enterprises, Inc.



amazon.com



VIEW CART

WISH LIST

YOUR ACCOUNT

HELP

WELCOME

YOUR STORE

BOOKS

APPAREL & ACCESSORIES

ELECTRONICS

TOYS & GAMES

MUSIC

CELL PHONES & SERVICE

SEE MORE STORES

Search

Browse Subjects

Bestsellers

Magazines

Corporate Accounts

e-books & docs

New & Used Textbooks

Used Books

Search:

Browse:

You clicked on this item...

The Arrl Antenna Book (ARRL Antenna Book)

by R. Dean Straw (Editor)

Average Customer Review: ★★★★★

Out of Print--Limited Availability

4 used & new from \$9.99

buy used: \$9.99

You may also be interested in these items...

Customers also shopped for

Show items from:

▶ All Products

Books (20)

DVD (2)

Software (1)

The ARRL Handbook for Radio Communications 2004

by Dana G. Reed

More like this



Practical Antenna Handbook

by Joseph J. Carr

More like this



The Arrl Extra Class License Manual (Arrl Extra Class License Manual for the Radio Amateur)

by Larry D. Wolfgang, et al

More like this



The Arrl General Class License Manual (Arrl General Class License Manual for the Radio Amateur)

by Larry D. Wolfgang

More like this



Now You're Talking!

by Larry D. Wolfgang, et al

More like this



The Arrl Operating Manual (Arrl Operating Manual)

by Steve Ford

More like this



RF Circuit Design

by Christopher Bowick

More like this



Antennas

by John D. Kraus, Ronald J. Marhefka

More like this



Ham Radio for Dummies

by Ward Silver

More like this

More results 

New at Amazon.com

Visit our new [Seasonal Tableware Store](#) and save up to 40% on Lenox, Spode, and more.

\$25 Off Tools & Hardware

\$25 Offer

Take \$25 off when you spend \$199 or more on [Tools & Hardware](#) products offered by Amazon.com. [Here's how](#) (restrictions apply).

New at Amazon.com



Find more than 600,000 china, crystal, and silver products in the [Replacements, Ltd. Store](#).

Where's My Stuff?

- Track your [recent orders](#).
- View or change your orders in [Your Account](#).

Shipping & Returns

- See our [shipping rates & policies](#).
- [Return](#) an item (here's our [Returns Policy](#)).

Need Help?

- Forgot your password? [Click here](#).
- [Redeem](#) or [buy](#) a gift certificate.
- [Visit our Help department](#).





Search

for





Your Recent History

[Learn More](#)

Recently Viewed Products

-  [The Wind in the Willows](#) by Kenneth Grahame, Michael Hague
-  [West With the Night](#) by Beryl Markham
-  [The Mirror of the Sea](#) by Joseph Conrad
-  [The Cruise of the Snark](#) by Jack London
-  [Sailing](#) by Henry Beard, Roy McKie

Customers who bought items in your Recent History also bought:

-   [Cooking](#) by Henry Beard, Roy McKie
-   [South Sea Tales \(Modern Library Classics\)](#) by Jack London, et al

[Visit the Page You Made](#)

Turn your past books purchases into \$\$\$
[Learn more](#) about selling at Amazon.com today!

[Top of Page](#)

[Books Search](#) | [Browse Subjects](#) | [Bestsellers](#) | [Magazines](#) | [Corporate Accounts](#)
[e-Books & Docs](#) | [Bargain Books](#) | [Used Books](#)

[Amazon.com Home](#) | [Directory of All Stores](#)

Our International Sites: [Canada](#) | [United Kingdom](#) | [Germany](#) | [Japan](#) | [France](#)

[Contact Us](#) | [Help](#) | [Shopping Cart](#) | [Your Account](#) | [Sell Items](#) | [1-Click Settings](#)

[Investor Relations](#) | [Press Releases](#) | [Join Our Staff](#)

[Conditions of Use](#) | [Privacy Notice](#) © 1996-2004, Amazon.com, Inc. or its affiliates



amazon.com.



VIEW CART | WISH LIST | YOUR ACCOUNT | HELP

WELCOME

YOUR STORE

BOOKS

APPAREL & ACCESSORIES

ELECTRONICS

TOYS & GAMES

MUSIC

CELL PHONES & SERVICE

SEE MORE STORES

Search

Browse Subjects

Bestsellers

Magazines

Corporate Accounts

e-books & docs

New & Used Textbooks

Used Books

Search:

Browse:

You clicked on this item...

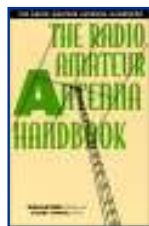

The Radio Amateur Antenna Handbook

by William I. Orr, Stuart D. Cowan

Average Customer Review: ★★★★★

Out of Print--Limited Availability

You may also be interested in these items...

Show items from:

All Products

Books (2)



Practical Antenna Handbook

by Joseph J. Carr

More like this



Vertical Antennas

by William Orr

More like this

New at Amazon.com

Visit our new [Seasonal Tableware Store](#) and save up to 40% on Lenox, Spode, and more.

\$25 Off Tools & Hardware

\$25 Offer

Take \$25 off when you spend \$199 or more on [Tools & Hardware](#) products offered by Amazon.com. [Here's how](#) (restrictions apply).

New at Amazon.com



REPLACEMENTS.LTD.

Find more than 600,000 china, crystal, and silver products in the [Replacements, Ltd. Store](#).

Where's My Stuff?

- Track your [recent orders](#).
- View or change your orders in [Your Account](#).

Shipping & Returns

- See our [shipping rates & policies](#).
- [Return](#) an item (here's our [Returns Policy](#)).

Need Help?

- Forgot your password? [Click here](#).
- [Redeem](#) or [buy](#) a gift certificate.
- [Visit our Help department](#).

Search

for

Your Recent History

[Learn More](#)

Recently Viewed Products

- [The Arrl Antenna Book \(ARRL Antenna Book\)](#) by R. Dean Straw (Editor)
- [The Wind in the Willows](#) by Kenneth Grahame, Michael Hague
- [West With the Night](#) by Beryl Markham
- [The Mirror of the Sea](#) by Joseph Conrad
- [The Cruise of the Snark](#) by Jack London

Customers who bought items in your Recent History also bought:

- [South Sea Tales \(Modern Library Classics\)](#) by Jack London, et al
- [Chance](#) by Joseph Conrad

▶ [Visit the Page You Made](#)

Turn your past books purchases into \$\$\$
[Learn more](#) about selling at Amazon.com today!

[Top of Page](#)

[Books Search](#) | [Browse Subjects](#) | [Bestsellers](#) | [Magazines](#) | [Corporate Accounts](#)
[e-Books & Docs](#) | [Bargain Books](#) | [Used Books](#)

[Amazon.com Home](#) | [Directory of All Stores](#)

Our International Sites: [Canada](#) | [United Kingdom](#) | [Germany](#) | [Japan](#) | [France](#)

[Contact Us](#) | [Help](#) | [Shopping Cart](#) | [Your Account](#) | [Sell Items](#) | [1-Click Settings](#)

[Investor Relations](#) | [Press Releases](#) | [Join Our Staff](#)

[Conditions of Use](#) | [Privacy Notice](#) © 1996-2004, Amazon.com, Inc. or its affiliates



amazon.com



VIEW CART | WISH LIST | YOUR ACCOUNT | HELP

WELCOME

YOUR STORE

BOOKS

APPAREL & ACCESSORIES

ELECTRONICS

TOYS & GAMES

MUSIC

CELL PHONES & SERVICE

SEE MORE STORES

Search

Browse Subjects

Bestsellers

Magazines

Corporate Accounts

e-books & docs

New & Used Textbooks

Used Books

SEARCH

WEB SEARCH

Powered by A9.com

Cubical Quad Antennas: How to Build and Adjust Quads

by William Orr, Stuart Cowan

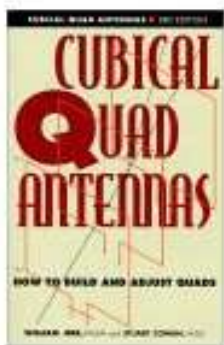

Availability: Usually ships within 1-2 business days

6 used & new from \$63.93

Edition: Paperback

Publisher: learn how customers can search inside this book.

See more product details

READY TO BUY?

6 used & new from \$63.93

See all buying options

Have one to sell? Sell yours here

Don't have one? We'll set one up for you.

Welcome to Books! Click here to explore more.

Top Sellers in Books:



- 1. Unfit for Command by John E. O'Neill, Jerome R. Corsi
2. Jonathan Strange & Mr. Norrell by Susanna Clarke
3. Trace (Kay Scarpetta Mysteries) by Patricia Cornwell

Product Details

- Paperback: ; Dimensions (in inches): 0.26 x 8.24 x 5.37
Publisher: Watson-Guptill Publications; 3rd edition (December 1, 1982)
ASIN: 0823087034
Amazon.com Sales Rank: 232,657
(Publishers and authors: improve your sales)

What's Your Advice?

Is there an item you'd recommend instead of or in addition to this one? Let the world know! Enter the item's ASIN (what's an ASIN?) in the box below, select advice type, then click Submit.

I recommend: in addition to this book
instead of this book

BOOK INFORMATION

buying info

Customer Reviews

Be the first person to review this book!

RECENTLY VIEWED

Customers who bought titles by William Orr also bought titles by these



[The Radio
Amateur Antenna
Handbook](#) by
William I. Orr,
Stuart D. Cowan



[The Arrl Antenna
Book \(ARRL
Antenna Book\)](#)
by R. Dean Straw
(Editor)



[The Wind in the
Willows](#) by
Kenneth
Grahame,
Michael Hague



[West With the
Night](#) by Beryl
Markham

▶ [See more in the Page
You Made](#)

Featured Item:



[The Lives of Beryl
Markham](#) by Errol
Trzebinski, Errol
Trzevinski

authors:

- [Rex Johnson Jr.](#)
- [Charles R. Meck](#)

▶ [Explore similar authors](#)

Listmania!

- [Ham radio, cb radio and shortwave listeninig books](#): A list by [dxzone.com](#), Amateur radio operator
-

Look for similar books by subject:

Search for books by subject:

- [Antennas](#)
- [Quad antennas](#)
- [Radio](#)
- [Shortwave radio](#)
- [Technology & Industrial Arts](#)

i.e., each book must be in subject 1 AND subject 2 AND ...

Feedback

- **I have read this book, and I want to [review it](#).**
- [E-mail a friend about this book.](#)
- [Write a So You'd Like to... guide.](#)
- Is there a specific product you'd like us to sell? [Tell us](#) about it.

RATE THIS BOOK

I dislike it I love it!

1 2 3 4 5

[Edit your ratings](#)

Favorite Magazines!



Explore our new
[Magazine](#)
[Subscriptions](#) store.

Suggestion Box

Your comments can help make our site better for everyone. If you've found something incorrect, broken, or frustrating on this page, let us know so that we can improve it. Please note that we are unable to respond directly to suggestions made via this form.

If you need help with an order, please [contact Customer Service](#).

Please mark as many of the following boxes that apply:

Product information is missing important details.

Product information is incorrect. Propose corrections using our [Online Catalog Update Form](#).

The page contains typographical errors.

The page takes too long to load.

The page has a software bug in it.

Content violates [Amazon.com's policy on offensive language](#).

Product offered violates [Amazon.com's policy](#) on items that can be listed for sale.

Comments or Examples:

Examples: Missing information such as dimensions and model number, typos, inaccuracies, etc.

Where's My Stuff?

- Track your [recent orders](#).
- View or change your orders in [Your Account](#).

Shipping & Returns

- See our [shipping rates & policies](#).
- [Return](#) an item (here's our [Returns Policy](#)).

Need Help?

- Forgot your password? [Click here](#).
- [Redeem](#) or [buy](#) a gift certificate.
- [Visit our Help department](#).





Search

for

Your Recent History

[Learn More](#)

Recently Viewed Products

-  [The Radio Amateur Antenna Handbook](#) by William I. Orr, Stuart D. Cowan
-  [The Arrl Antenna Book \(ARRL Antenna Book\)](#) by R. Dean Straw (Editor)
-  [The Wind in the Willows](#) by Kenneth Grahame, Michael Hague
-  [West With the Night](#) by Beryl Markham
-  [The Mirror of the Sea](#) by Joseph Conrad

Customers who bought items in your Recent History also bought:

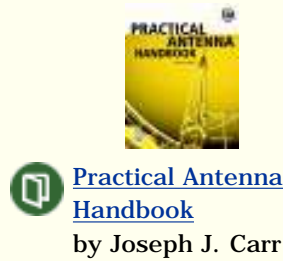

[Visit the Page You Made](#)

Turn your past books purchases into \$\$\$
[Learn more](#) about selling at Amazon.com today!

[Top of Page](#)

[Books Search](#) | [Browse Subjects](#) | [Bestsellers](#) | [Magazines](#) | [Corporate Accounts](#)
[e-Books & Docs](#) | [Bargain Books](#) | [Used Books](#)

[Amazon.com Home](#) | [Directory of All Stores](#)

Our International Sites: [Canada](#) | [United Kingdom](#) | [Germany](#) | [Japan](#) | [France](#)

[Contact Us](#) | [Help](#) | [Shopping Cart](#) | [Your Account](#) | [Sell Items](#) | [1-Click Settings](#)

[Investor Relations](#) | [Press Releases](#) | [Join Our Staff](#)

[Conditions of Use](#) | [Privacy Notice](#) © 1996-2004, Amazon.com, Inc. or its affiliates



SEARCH

WEB SEARCH

Powered by A9.com

Beam Antenna Handbook

by [William I. Orr](#), [Stuart D. Cowan](#)

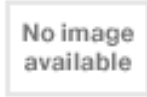

Availability: Usually ships within 1-2 business days

8 used & new from \$9.99

Edition: Paperback

READY TO BUY?

8 used & new from \$9.99

[See all buying options](#)

Have one to sell? [Sell yours here](#)

▶ [See more product details](#)

Don't have one?
We'll set one up for you.

Welcome to Books!
[Click here to explore more.](#)

Top Sellers in Books:



- [Unfit for Command](#) by John E. O'Neill, Jerome R. Corsi
- [Jonathan Strange & Mr. Norrell](#) by Susanna Clarke
- [Trace \(Kay Scarpetta Mysteries\)](#) by Patricia Cornwell

Product Details

- **Paperback:** ; Dimensions (in inches): 0.59 x 8.43 x 5.40
- **Publisher:** Rac Books; (November 1, 1990)
- **ASIN:** 0823087042
- **Average Customer Review:** ★★★★★ Based on 1 review. [Write a review.](#)
- **Amazon.com Sales Rank:** 433,368
(Publishers and authors: [improve your sales](#))

What's Your Advice?

Is there an item you'd recommend instead of or in addition to this one? Let the world know! Enter the item's ASIN ([what's an ASIN?](#)) in the box below, select advice type, then click Submit.

I recommend: _____ in addition to this book
_____ instead of this book

All Customer Reviews

Average Customer Review: ★★★★★

[Write an online review](#) and share your thoughts with other customers.

4 of 5 people found the following review helpful:

★★★★★ **A very good antenna reading, elucidating and taboo breaking.**,
September 22, 1999

Reviewer: **A reader**

As wrote on the back cover: Before buying or build your beam antenna, take a moment

BOOK INFORMATION

[buying info](#)
[customer reviews](#)

RECENTLY VIEWED

 [Cubical Quad Antennas: How to Build and Adjust Quads](#) by William Orr, Stuart Cowan

 [The Radio Amateur Antenna Handbook](#) by William I. Orr, Stuart D. Cowan

 [The Arrl Antenna Book \(ARRL Antenna Book\)](#) by R. Dean Straw (Editor)

 [The Wind in the Willows](#) by Kenneth Grahame, Michael Hague

▶ [See more in the Page You Made](#)

Featured Item:



[The Beginner's Handbook of Amateur Radio](#) by Clay Laster

RATE THIS BOOK

I dislike it I love it!

1 2 3 4 5

[Edit your ratings](#)

to read this book. It will guide you away of the many myths and bad-practices.

Was this review helpful to you? **yes** **no** [\(Report this\)](#)

Customers who bought titles by William I. Orr also bought titles by these authors:

- [Joseph J. Carr](#)
- [Steve Winder](#)
- [R. Dean Straw](#)
- [Cotter W. Sayre](#)
- [Ann Coulter](#)

▶ [Explore similar authors](#)

Look for similar books by subject:

Search for books by subject:

[Radio](#)

[Technology & Industrial Arts](#)

i.e., each book must be in subject 1 AND subject 2 AND ...

Feedback

- **I have read this book, and I want to [review it](#).**
- [E-mail a friend about this book.](#)
- [Write a So You'd Like to... guide.](#)
- Is there a specific product you'd like us to sell? [Tell us](#) about it.

Favorite Magazines!



Explore our new [Magazine Subscriptions](#) store.

Suggestion Box

Your comments can help make our site better for everyone. If you've found something incorrect, broken, or frustrating on this page, let us know so that we can improve it. Please note that we are unable to respond directly to suggestions made via this form.

If you need help with an order, please [contact Customer Service](#).

Please mark as many of the following boxes that apply:

Product information is missing important details.

Product information is incorrect. Propose corrections using our [Online Catalog Update Form](#).

The page contains typographical errors.

The page takes too long to load.

The page has a software bug in it.

Content violates [Amazon.com's policy on offensive language](#).

Product offered violates [Amazon.com's policy](#) on items that can be listed for sale.

Comments or Examples:

Examples: Missing information such as dimensions and model number, typos, inaccuracies, etc.

Where's My Stuff?

- Track your [recent orders](#).
- View or change your orders in [Your Account](#).

Shipping & Returns

- See our [shipping rates & policies](#).
- [Return](#) an item (here's our [Returns Policy](#)).

Need Help?

- Forgot your password? [Click here](#).
- [Redeem](#) or [buy](#) a gift certificate.
- [Visit our Help department](#).





Search

for

Your Recent History

[Learn More](#)

Recently Viewed Products

-  [Cubical Quad Antennas](#) by William Orr, Stuart Cowan
-  [The Radio Amateur Antenna Handbook](#) by William I. Orr, Stuart D. Cowan
-  [The Arrl Antenna Book \(ARRL Antenna Book\)](#) by R. Dean Straw (Editor)
-  [The Wind in the Willows](#) by Kenneth Grahame, Michael Hague
-  [West With the Night](#) by Beryl Markham

Customers who bought items in your Recent History also bought:



 [Practical Antenna Handbook](#)
by Joseph J. Carr

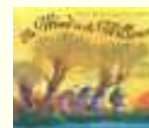

 [The Wind in the Willows](#)
by Kenneth Grahame, Michael Foreman

[Visit the Page You Made](#)

Turn your past books purchases into \$\$\$
[Learn more](#) about selling at Amazon.com today!

[Top of Page](#)

[Books Search](#) | [Browse Subjects](#) | [Bestsellers](#) | [Magazines](#) | [Corporate Accounts](#)
[e-Books & Docs](#) | [Bargain Books](#) | [Used Books](#)

[Amazon.com Home](#) | [Directory of All Stores](#)

Our International Sites: [Canada](#) | [United Kingdom](#) | [Germany](#) | [Japan](#) | [France](#)

[Contact Us](#) | [Help](#) | [Shopping Cart](#) | [Your Account](#) | [Sell Items](#) | [1-Click Settings](#)

[Investor Relations](#) | [Press Releases](#) | [Join Our Staff](#)

[Conditions of Use](#) | [Privacy Notice](#) © 1996-2004, Amazon.com, Inc. or its affiliates



amazon.com



VIEW CART | WISH LIST | YOUR ACCOUNT | HELP

WELCOME

YOUR STORE

BOOKS

APPAREL & ACCESSORIES

ELECTRONICS

TOYS & GAMES

MUSIC

CELL PHONES & SERVICE

SEE MORE STORES

Search

Browse Subjects

Bestsellers

Magazines

Corporate Accounts

e-books & docs

New & Used Textbooks

Used Books

SEARCH

Simple Low Cost Wire Antennae

by [Orr](#)

No image available

Availability: Usually ships within 1-2 business days

4 used & new from \$30.19

Edition: Paperback

READY TO BUY?

4 used & new from \$30.19

See all buying options

Have one to sell?

Sell yours here

WEB SEARCH

Powered by A9.com

See more product details

Don't have one? We'll set one up for you.

Welcome to Books! Click here to explore more.

Top Sellers in Books:



- [Unfit for Command](#) by John E. O'Neill, Jerome R. Corsi
- [Jonathan Strange & Mr. Norrell](#) by Susanna Clarke
- [Trace \(Kay Scarpetta Mysteries\)](#) by Patricia Cornwell

Product Details

- Paperback:** ; Dimensions (in inches): 0.41 x 8.24 x 5.39
- Publisher:** Rac Books; (November 1, 1990)
- ASIN:** 0823087077
- Average Customer Review:** ★★★★★ Based on 2 reviews. [Write a review.](#)
- Amazon.com Sales Rank:** 617,108 (Publishers and authors: [improve your sales](#))

What's Your Advice?

Is there an item you'd recommend instead of or in addition to this one? Let the world know! Enter the item's ASIN ([what's an ASIN?](#)) in the box below, select advice type, then click Submit.

I recommend: _____ in addition to this book
 _____ instead of this book

All Customer Reviews

Average Customer Review: ★★★★★

[Write an online review](#) and share your thoughts with other customers.

★★★★★ An excellent basic text, January 29, 2004

Reviewer: "[dalmatians2k](#)" (Maine, NY USA) - [See all my reviews](#)

It seems that today's amateur radio operator more often than not has a station consisting of manufactured equipment. At the heart of these stations are transceivers so complex that the average ham has neither the equipment nor the ability to fix or modify them. Antennas are, however, something that still attract homebrewers.

BOOK INFORMATION

buying info
[customer reviews](#)

RECENTLY VIEWED

 [Beam Antenna Handbook](#) by William I. Orr, Stuart D. Cowan

 [Cubical Quad Antennas: How to Build and Adjust Quads](#) by William Orr, Stuart Cowan

 [The Radio Amateur Antenna Handbook](#) by William I. Orr, Stuart D. Cowan

 [The Arrl Antenna Book \(ARRL Antenna Book\)](#) by R. Dean Straw (Editor)

[See more in the Page You Made](#)

Featured Item:



[The Beginner's Handbook of Amateur Radio](#) by Clay Laster

If you're going to put up an antenna, why not do it right and get the best performance for the time spent? For a low key yet effective introduction to wire antennas this is a wonderful little book. Nowhere near as long, or complex, as the ARRL Antenna Handbook, this concise volume presents some elementary theory and a number of practical designs for wire antennas. I've lent my copy to new hams several times and from all reports it's been a big help.

This book is highly recommended as a basic reference and a good stepping stone to the next level.

Was this review helpful to you? [\(Report this\)](#)

★★★★★ Simple low cost wire antennas for radio amateurs, April 10, 2002

Reviewer: [Javier Carvajal](#) (Costa Rica) - [See all my reviews](#)

That book is full load with prctical information for any ham beginner who wants to learn by doing wire antennas. It is really helpfull, and well oriented

Was this review helpful to you? [\(Report this\)](#)

Look for similar books by subject:

Search for books by subject:

- [Radio](#)
- [Radio - General](#)
- [Science/Mathematics](#)
- [Technology & Industrial Arts](#)

i.e., each book must be in subject 1 AND subject 2 AND ...

Feedback

- **I have read this book, and I want to [review](#) it.**
- [E-mail a friend about this book.](#)
- [Write a So You'd Like to... guide.](#)
- Is there a specific product you'd like us to sell? [Tell us](#) about it.

RATE THIS BOOK

I dislike it I love it!

1 2 3 4 5

[Edit your ratings](#)

Favorite Magazines!



Explore our new
[Magazine
Subscriptions
store.](#)

Suggestion Box

Your comments can help make our site better for everyone. If you've found something incorrect, broken, or frustrating on this page, let us know so that we can improve it. Please note that we are unable to respond directly to suggestions made via this form.

If you need help with an order, please [contact Customer Service](#).

Please mark as many of the following boxes that apply:

Product information is missing important details.

Product information is incorrect. Propose corrections using our [Online Catalog Update Form](#).

The page contains typographical errors.

The page takes too long to load.

The page has a software bug in it.

Content violates [Amazon.com's policy on offensive language](#).

Product offered violates [Amazon.com's policy](#) on items that can be listed for sale.

Comments or Examples:

Examples: Missing information such as dimensions and model number, typos, inaccuracies, etc.

Where's My Stuff?

- Track your [recent orders](#).
- View or change your orders in [Your Account](#).

Shipping & Returns

- See our [shipping rates & policies](#).
- [Return](#) an item (here's our [Returns Policy](#)).

Need Help?

- Forgot your password? [Click here](#).
- [Redeem](#) or [buy](#) a gift certificate.
- [Visit our Help department](#).





Search

for

Your Recent History

[Learn More](#)

Recently Viewed Products

-  [Beam Antenna Handbook](#) by William I. Orr, Stuart D. Cowan
-  [Cubical Quad Antennas](#) by William Orr, Stuart Cowan
-  [The Radio Amateur Antenna Handbook](#) by William I. Orr, Stuart D. Cowan
-  [The Arrl Antenna Book \(ARRL Antenna Book\)](#) by R. Dean Straw (Editor)
-  [The Wind in the Willows](#) by Kenneth Grahame, Michael Hague

Customers who bought items in your Recent History also bought:



-  [Practical Antenna Handbook](#) by Joseph J. Carr



-  [Antenna Engineering Handbook](#) by Richard C. Johnson

▶ [Visit the Page You Made](#)

Turn your past books purchases into \$\$\$
[Learn more](#) about selling at Amazon.com today!

[Top of Page](#)

[Books Search](#) | [Browse Subjects](#) | [Bestsellers](#) | [Magazines](#) | [Corporate Accounts](#)
[e-Books & Docs](#) | [Bargain Books](#) | [Used Books](#)

[Amazon.com Home](#) | [Directory of All Stores](#)

Our International Sites: [Canada](#) | [United Kingdom](#) | [Germany](#) | [Japan](#) | [France](#)

[Contact Us](#) | [Help](#) | [Shopping Cart](#) | [Your Account](#) | [Sell Items](#) | [1-Click Settings](#)

[Investor Relations](#) | [Press Releases](#) | [Join Our Staff](#)

[Conditions of Use](#) | [Privacy Notice](#) © 1996-2004, Amazon.com, Inc. or its affiliates

Shop in **Musical Instruments** (Beta-What is this?) | **amazon.com** | VIEW CART | WISH LIST | YOUR ACCOUNT | HELP

WELCOME | YOUR STORE | **BOOKS** | APPAREL & ACCESSORIES | ELECTRONICS | TOYS & GAMES | MUSIC | CELL PHONES & SERVICE | SEE MORE STORES

Search | Browse Subjects | Bestsellers | Magazines | Corporate Accounts | e-books & docs | New & Used Textbooks | Used Books

Search: Browse:

You clicked on this item...

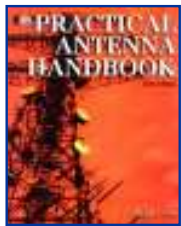

Practical Antenna Handbook

by [Joseph J. Carr](#)

Average Customer Review:
 Out of Print--Limited Availability

3 used & new from \$28.00

[buy used:](#) \$28.00

From Book News, Inc.

Designed for use by the novice as well as the professional, this book/CD- ROM combo gives the reader all kinds of projects with material that explains why they work. A wide variety of antennae are covered: high frequency dipole, vertically polarized HF, multiband and tunable wire, hidden and limited... [Read more](#)

You may also be interested in these items...

[Customers also shopped for](#)

Show items from:

- ▶ **All Products**
- [Books](#) (20)
- [DVD](#) (3)

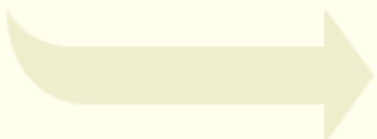

| | | |
|--|---|---|
| <p><u>The Arrl Antenna Book</u> by R. Dean Straw More like this</p> | <p><u>The ARRL Handbook for Radio Communications 2004</u> by Dana G. Reed More like this</p> | <p><u>Antenna Toolkit</u> by Joseph J. Carr, Joe Carr More like this</p> |
| <p><u>Practical Radio Frequency Test and Measurement</u> by Joseph J. Carr More like this</p> | <p><u>Antennas</u> by John D. Kraus, Ronald J. Marhefka More like this</p> | <p><u>Electromagnetics Explained</u> by Ron Schmitt More like this</p> |



Antenna Engineering Handbook

by Richard C. Johnson

[More like this](#)



Now You're Talking!

by Larry D. Wolfgang, et al

[More like this](#)

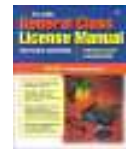

The Arrl General Class License Manual (Arrl General Class License Manual for the Radio Amateur)

by Larry D. Wolfgang

[More like this](#)

[More results](#) ▶

New at Amazon.com

Visit our new [Seasonal Tableware Store](#) and save up to 40% on Lenox, Spode, and more.

\$25 Off Tools & Hardware

\$25 Offer

Take \$25 off when you spend \$199 or more on [Tools & Hardware](#) products offered by Amazon.com. [Here's how](#) (restrictions apply).

New at Amazon.com



REPLACEMENTS, LTD.

Find more than 600,000 china, crystal, and silver products in the [Replacements, Ltd. Store](#).

Where's My Stuff?

- Track your [recent orders](#).
- View or change your orders in [Your Account](#).

Shipping & Returns

- See our [shipping rates & policies](#).
- [Return](#) an item (here's our [Returns Policy](#)).

Need Help?

- Forgot your password? [Click here](#).
- [Redeem](#) or [buy](#) a gift certificate.
- [Visit our Help department](#).





Search

for

Your Recent History

[Learn More](#)

Recently Viewed Products

-  [Simple Low Cost Wire Antennae](#) by Orr
-  [Beam Antenna Handbook](#) by William I. Orr, Stuart D. Cowan
-  [Cubical Quad Antennas](#) by William Orr, Stuart Cowan
-  [The Radio Amateur Antenna Handbook](#) by William I. Orr, Stuart D. Cowan
-  [The Arrl Antenna Book \(ARRL Antenna Book\)](#) by R. Dean Straw (Editor)

Customers who bought items in your Recent History also bought:



 [Practical Antenna Handbook](#)
by Joseph J. Carr



 [The Arrl Extra Class License Manual \(Arrl Extra Class License Manual for the Radio Amateur\)](#)
by Larry D. Wolfgang, et al

▶ [Visit the Page You Made](#)

Turn your past books purchases into \$\$\$

[Learn more](#) about selling at Amazon.com today!

[Top of Page](#)

**[Books Search](#) | [Browse Subjects](#) | [Bestsellers](#) | [Magazines](#) | [Corporate Accounts](#)
[e-Books & Docs](#) | [Bargain Books](#) | [Used Books](#)**

[Amazon.com Home](#) | [Directory of All Stores](#)

Our International Sites: [Canada](#) | [United Kingdom](#) | [Germany](#) | [Japan](#) | [France](#)

[Contact Us](#) | [Help](#) | [Shopping Cart](#) | [Your Account](#) | [Sell Items](#) | [1-Click Settings](#)

[Investor Relations](#) | [Press Releases](#) | [Join Our Staff](#)

[Conditions of Use](#) | [Privacy Notice](#) © 1996-2004, Amazon.com, Inc. or its affiliates



amazon.com



VIEW CART

WISH LIST

YOUR ACCOUNT

HELP

WELCOME

YOUR STORE

BOOKS

APPAREL & ACCESSORIES

ELECTRONICS

TOYS & GAMES

MUSIC

CELL PHONES & SERVICE

SEE MORE STORES

Search

Browse Subjects

Bestsellers

Magazines

Corporate Accounts

e-books & docs

New & Used Textbooks

Used Books

Search:

Browse:

You clicked on this item...

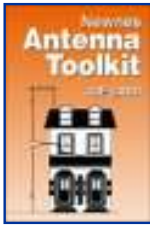

Antenna Toolkit

by [Joe Carr](#)

Out of Print--Limited Availability

From Book News, Inc.

A guide for both experienced and new designers and engineers. Reviews the basics of radio signals and antennas then describes the components, the various types, and tasks such as matching impedance and measurements. The CD-ROM for Windows 95 provides all the necessary software for calculating the... [Read more](#)

You may also be interested in these items...

Show items from:

▶ **All Products**

[Books](#) (8)



Practical Antenna Handbook

by Joseph J. Carr

[More like this](#)



Practical Radio Frequency Test and Measurement

by Joseph J. Carr

[More like this](#)

The Arri Antenna Book

by R. Dean Straw

[More like this](#)

The ARRL Handbook for Radio Communications

2004

by Dana G. Reed

[More like this](#)



Electrical Components

by Delton T. Horn

[More like this](#)

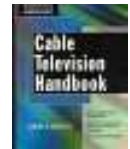

Cable Television Handbook

by Eugene R Bartlett, Eugene R. Bartlett

[More like this](#)

Pipe and Excavation Contracting

by Dave Roberts

[More like this](#)



Electromagnetics Explained

by Ron Schmitt

[More like this](#)

New at Amazon.com

Visit our new [Seasonal Tableware Store](#) and save up to 40% on Lenox, Spode, and more.

\$25 Off Tools & Hardware

\$25 Offer

Take \$25 off when you spend \$199 or more on [Tools & Hardware](#) products offered by Amazon.com. [Here's how](#) (restrictions apply).

New at Amazon.com



Find more than 600,000 china, crystal, and silver products in the [Replacements, Ltd. Store](#).

Where's My Stuff?

- Track your [recent orders](#).
- View or change your orders in [Your Account](#).

Shipping & Returns

- See our [shipping rates & policies](#).
- [Return](#) an item (here's our [Returns Policy](#)).

Need Help?

- Forgot your password? [Click here](#).
- [Redeem](#) or [buy](#) a gift certificate.
- [Visit our Help department](#).

Search

for

Your Recent History

[Learn More](#)

Recently Viewed Products

- [Practical Antenna Handbook](#) by Joseph J. Carr
- [Simple Low Cost Wire Antennae](#) by Orr
- [Beam Antenna Handbook](#) by William I. Orr, Stuart D. Cowan
- [Cubical Quad Antennas](#) by William Orr, Stuart Cowan
- [The Radio Amateur Antenna Handbook](#) by William I. Orr, Stuart D. Cowan

Customers who bought items in your Recent History also bought:

- [Antenna Toolkit](#) by Joseph J. Carr, Joe Carr
- [Antennas](#) by John D. Kraus, Ronald J. Marhefka

▶ Visit the Page You Made

Turn your past books purchases into \$\$\$
[Learn more about selling at Amazon.com today!](#)

[Top of Page](#)

[Books Search](#) | [Browse Subjects](#) | [Bestsellers](#) | [Magazines](#) | [Corporate Accounts](#)
[e-Books & Docs](#) | [Bargain Books](#) | [Used Books](#)

[Amazon.com Home](#) | [Directory of All Stores](#)

Our International Sites: [Canada](#) | [United Kingdom](#) | [Germany](#) | [Japan](#) | [France](#)

[Contact Us](#) | [Help](#) | [Shopping Cart](#) | [Your Account](#) | [Sell Items](#) | [1-Click Settings](#)

[Investor Relations](#) | [Press Releases](#) | [Join Our Staff](#)



SEARCH

WEB SEARCH

Powered by A9.com

Lew McCoy on Antennas

by [Lew McCoy](#)

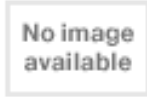

List Price: \$15.95

Price: **\$15.95** & eligible for **FREE Super Saver Shipping** on orders over \$25. [See details.](#)

Availability: Usually ships within 24 hours

[Search inside this book](#) **Only 1 left in stock--order soon (more on the way).**

3 used & new from \$15.95

Edition: Paperback

[See more product details](#)

Product Details

- **Paperback:** 112 pages ; Dimensions (in inches): 11.25 x 0.50 x 9.00
- **Publisher:** C Q Communications, Incorporated; (February 1, 1995)
- **ISBN:** 0943016088
- **Amazon.com Sales Rank:** 880,348
(Publishers and authors: [improve your sales](#))

NEW [Search Inside This Book](#) ([more info](#))

Search inside this book:

You can [view sample pages](#) from this book.

What's Your Advice?

Is there an item you'd recommend instead of or in addition to this one? Let the world know! Enter the item's ASIN ([what's an ASIN?](#)) in the box below, select advice type, then click Submit.

I recommend: _____ in addition to this book
_____ instead of this book

Editorial Reviews

Book Description

READY TO BUY?

or

[Sign in](#) to turn on 1-Click ordering.

MORE BUYING CHOICES

3 used & new from \$15.95

Have one to sell? [Sell yours here](#)

Don't have one?
We'll set one up for you.

Welcome to Books!
[Click here](#) to explore more.

Top Sellers in Books:







1. [Unfit for Command](#) by John E. O'Neill, Jerome R. Corsi
2. [Jonathan Strange & Mr. Norrell](#) by Susanna Clarke
3. [Trace \(Kay Scarpetta Mysteries\)](#) by Patricia Cornwell

BOOK INFORMATION

[buying info](#)

[search inside](#) **NEW**

RECENTLY VIEWED

-  [Antenna Toolkit](#)
by Joe Carr
-  [Practical Antenna Handbook](#) by Joseph J. Carr
-  [Simple Low Cost Wire Antennae](#) by Orr
-  [Beam Antenna Handbook](#) by William I. Orr, Stuart D. Cowan

▶ [See more in the Page You Made](#)

Featured Item:

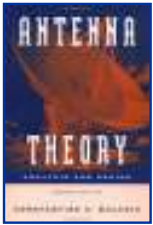

[Antenna Theory](#) by Constantine A. Balanis

RATE THIS BOOK

I dislike it I love it!

1 2 3 4 5

[Edit your ratings](#)

Unlike many technical publications, Lew presents his invaluable antenna information in a casual, non-intimidating way for anyone!

Customer Reviews

Be the first person to review this [book!](#)

Auctions and zShops sellers and our other stores recommend:

- [CQ The Radio Amateur's Journal \(Price: \\$31.95\)](#)
- [CQ VHF \(Price: \\$25.00\)](#)

Look for similar books by subject:

Browse for [books](#) in:

- [Subjects](#) > [Home & Garden](#) > [Crafts & Hobbies](#) > [General](#)

Search for books by subject:

- [Crafts & Hobbies](#)
- [Electronics - General](#)
- [General](#)
- [Hobbies/Crafts](#)
- [Technology & Industrial Arts](#)

i.e., each book must be in subject 1 AND subject 2 AND ...

Feedback

- **I have read this book, and I want to [review](#) it.**
- [E-mail a friend about this book.](#)
- [Write a So You'd Like to... guide.](#)
- Is there a specific product you'd like us to sell? [Tell us](#) about it.

Favorite Magazines!



Explore our new [Magazine Subscriptions store.](#)

Suggestion Box

Your comments can help make our site better for everyone. If you've found something incorrect, broken, or frustrating on this page, let us know so that we can improve it. Please note that we are unable to respond directly to suggestions made via this form.

If you need help with an order, please [contact Customer Service](#).

Please mark as many of the following boxes that apply:

Product information is missing important details.

Product information is incorrect. Propose corrections using our [Online Catalog Update Form](#).

The page contains typographical errors.

The page takes too long to load.

The page has a software bug in it.

Content violates [Amazon.com's policy on offensive language](#).

Product offered violates [Amazon.com's policy](#) on items that can be listed for sale.

Comments or Examples:

Examples: Missing information such as dimensions and model number, typos, inaccuracies, etc.

Where's My Stuff?

- Track your [recent orders](#).
- View or change your orders in [Your Account](#).

Shipping & Returns

- See our [shipping rates & policies](#).
- [Return](#) an item (here's our [Returns Policy](#)).

Need Help?

- Forgot your password? [Click here](#).
- [Redeem](#) or [buy](#) a gift certificate.
- [Visit our Help department](#).





Search

for

Your Recent History

[Learn More](#)

Recently Viewed Products

-  [Antenna Toolkit](#) by Joe Carr
-  [Practical Antenna Handbook](#) by Joseph J. Carr
-  [Simple Low Cost Wire Antennae](#) by Orr
-  [Beam Antenna Handbook](#) by William I. Orr, Stuart D. Cowan
-  [Cubical Quad Antennas](#) by William Orr, Stuart Cowan

Customers who bought items in your Recent History also bought:



 [Antenna Engineering Handbook](#)
by Richard C. Johnson

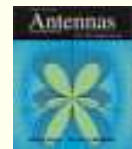

 [Antennas](#)
by John D. Kraus,
Ronald J. Marhefka

[▶ Visit the Page You Made](#)

Turn your past books purchases into \$\$\$
[Learn more](#) about selling at Amazon.com today!

[Top of Page](#)

[Books Search](#) | [Browse Subjects](#) | [Bestsellers](#) | [Magazines](#) | [Corporate Accounts](#)
[e-Books & Docs](#) | [Bargain Books](#) | [Used Books](#)

[Amazon.com Home](#) | [Directory of All Stores](#)

Our International Sites: [Canada](#) | [United Kingdom](#) | [Germany](#) | [Japan](#) | [France](#)

[Contact Us](#) | [Help](#) | [Shopping Cart](#) | [Your Account](#) | [Sell Items](#) | [1-Click Settings](#)

[Investor Relations](#) | [Press Releases](#) | [Join Our Staff](#)

[Conditions of Use](#) | [Privacy Notice](#) © 1996-2004, Amazon.com, Inc. or its affiliates



amazon.com



VIEW CART

WISH LIST

YOUR ACCOUNT

HELP

WELCOME

YOUR STORE

BOOKS

APPAREL & ACCESSORIES

ELECTRONICS

TOYS & GAMES

MUSIC

CELL PHONES & SERVICE

SEE MORE STORES

Search

Browse Subjects

Bestsellers

Magazines

Corporate Accounts

e-books & docs

New & Used Textbooks

Used Books

Search:

Browse:

You clicked on this item...

ON4UN's Low Band DXing

Price: **\$29.95**

by [John Devoldere](#)

Usually ships in 24 hours



This item ships for **FREE** with **Super Saver Shipping**. [See details.](#)

You may also be interested in these items...

Show items from:

▶ **All Products**

[Books](#) (1)



[The ARRL Handbook for Radio Communications 2004](#)

by Dana G. Reed

[More like this](#)

New at Amazon.com

Visit our new [Seasonal Tableware Store](#) and save up to 40% on Lenox, Spode, and more.

\$25 Off Tools & Hardware

\$25 Offer

Take \$25 off when you spend \$199 or more on [Tools & Hardware](#) products offered by Amazon.com. [Here's how](#) (restrictions apply).

New at Amazon.com



REPLACEMENTS, LTD.

Find more than 600,000 china, crystal, and silver products in the [Replacements, Ltd. Store](#).

Where's My Stuff?

- Track your [recent orders](#).
- View or change your orders in [Your Account](#).

Shipping & Returns

- See our [shipping rates & policies](#).
- [Return](#) an item (here's our [Returns Policy](#)).

Need Help?

- Forgot your password? [Click here](#).
- [Redeem](#) or [buy](#) a gift certificate.
- [Visit our Help department](#).

Search

for

Your Recent History

[Learn More](#)

Recently Viewed Products

- [Lew McCoy on Antennas](#) by Lew McCoy
- [Antenna Toolkit](#) by Joe Carr
- [Practical Antenna Handbook](#) by Joseph J. Carr
- [Simple Low Cost Wire Antennae](#) by Orr
- [Beam Antenna Handbook](#) by William I. Orr, Stuart D. Cowan

Customers who bought items in your Recent History also bought:



- [Practical Radio Frequency Test and Measurement](#) by Joseph J. Carr



- [Electromagnetics Explained](#) by Ron Schmitt

[▶ Visit the Page You Made](#)

Turn your past books purchases into \$\$\$
[Learn more](#) about selling at Amazon.com today!

[Top of Page](#)

[Books Search](#) | [Browse Subjects](#) | [Bestsellers](#) | [Magazines](#) | [Corporate Accounts](#)
[e-Books & Docs](#) | [Bargain Books](#) | [Used Books](#)

[Amazon.com Home](#) | [Directory of All Stores](#)

Our International Sites: [Canada](#) | [United Kingdom](#) | [Germany](#) | [Japan](#) | [France](#)

[Contact Us](#) | [Help](#) | [Shopping Cart](#) | [Your Account](#) | [Sell Items](#) | [1-Click Settings](#)

[Investor Relations](#) | [Press Releases](#) | [Join Our Staff](#)

[Conditions of Use](#) | [Privacy Notice](#) © 1996-2004, Amazon.com, Inc. or its affiliates

AC6V's

Amateur Radio and DX Reference Guide

★ **700 AMATEUR RADIO TOPICS, 6,000 LINKS, 132 PAGES** ★

ANTENNAS



TO ZONES

[SEND](#)  [AC6V](#)

[HELP SUPPORT THE AC6V SITE -- BUY THRU AMAZON](#)

★ **HAM BOOKS BY AC6V** ★

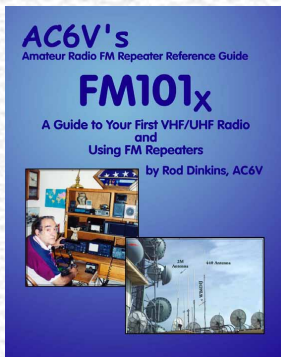

[FM101x](#)

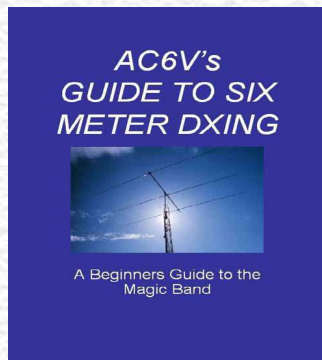

[Six Meters](#)

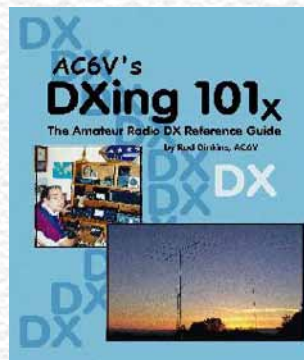

[DX101x](#)



[Crosswords](#)

DX101 AND FM101 NOW AVAILABLE AT HAM STORES -- CLICK ON BOOK TITLE FOR OUTLINE, SAMPLES AND STORES

[See Reader Reviews Of DX101x](#) [See Reader Reviews Of FM101x](#)



[FOR GREAT RIG PROGRAMMING GUIDES](#)













[SEE NIFTY ACCESSORIES](#)



 **CHOOSE YOUR AREA OF INTEREST** 

The Most Popular Pages

Check Here If You Want To Open Links In A New Window

| | | |
|---|---|--|
| 1. MASTER INDEX | 11. ANTENNA SOFTWARE | 21. KITS |
| 2. ANTENNA PROJECTS | 12. SWAP SITES | 22. PROPAGATION |
| 3. SOFTWARE | 13. LOGGING | 23. CALLING FREQS |
| 4. TECH REFERENCE | 14. HAM STORES | 24. HF NETS |
| 5. MANUALS | 15. OPERATING MODES | 25. HAM HISTORY |
| 6. FREQ/BAND PLANS | 16. REPEATER GUIDES ECHOLINK | 26. DEALERS,MFG,STORES |
| 7. SWL/SCANNER/BC | 17. PREFIXES | 27. HAM HELP |
| 8. ANTENNA DEALERS | 18. BOATANCHORS/ANTIQUE | 28. CONTEST PAGES |
| 9. HOMEBREW | 19. OPERATING AIDS | 29. DX PAGES & DXPEDITIONS |
| 10. MORSE AIDS PROGRAMS | 20. CALLBOOKS & QSL | 30. PRODUCT REVIEWS |
|  SAN DIEGO HAM GUIDE |  UTC TIME  PDT TIME |  AC6V BRAG TAPE |
|  SAN DIEGO TOURISM |  SFI A & K INDEX |  AC6V HUMOR  |
|  LATEST HAM NEWS |  QUICK INDEX |  AC6V BOOKS  |

✓ [SEARCH THE AC6V SITE](#) ✓

[IF YOU KNOW HOW – CLICK HERE](#)
[FOR SEARCH INSTRUCTIONS - CLICK HERE](#)

✓ [THE GATEWAY INDEX TO AMATEUR RADIO](#) ✓
[A](#) [B](#) [C](#) [D](#) [E](#) [F](#) [G](#) [H](#) [I](#) [J](#) [K](#) [L](#) [M](#) [N](#) [O](#) [P](#) [Q](#) [R](#) [S](#) [T](#) [U](#) [V](#) [W](#) [X](#) [Y](#) [Z](#) [0-9](#)

- [Abbreviations, CW](#)
- [Abbreviations, Ham](#)
- [Accessories, TechRef](#)
- [Accessories, Manufacturers](#)
- [Acronyms](#)
- [Alias For E-Mail](#)
- [Alphabets/Phonetic](#)
- [Amateur's Code Of Conduct](#)
- [Amateur Web Sites](#)
- [AM Broadcast Stations](#)
- [AM'ers](#)
- [Amplifiers,Mfg](#)
- [Amplifier Reviews](#)
- [Amplifier,Theory](#)
- [AMSAT](#)
- [amsat.org e-mail](#)
- [AMTOR](#)
- [Antenna Analyzers](#)
- [Discussions](#)
- [Manufacturers](#)
- [Antenna CC&Rs](#)
- [Antennas,Mfg](#)
- [Antennas,Projects](#)
- [Antenna Reviews](#)
- [Antenna Software](#)
- [Antennas, Stealth](#)
- [Antenna Theory](#)
- [Antique Radios](#)
- [Antique Wireless](#)
- [APRS](#)
- [Area Codes](#)
- [ARES](#)
- [ARRL Awards](#)
- [ARRL Home Page](#)
- [ARRL Index](#)
- [ARRL Logos](#)
- [ARRL Mail Lists](#)
- [ARRL E-Mail Alias](#)
- [ARRL Sections](#)
- [ARRL Sect, Abbrev](#)
- [Astronauts/Sarex Calls](#)
- [Astronomy, Radio](#)
- [Attenuator Design](#)
- [Atlas, Ham](#)
- [ATV](#)
- [GeoClock](#)
- [Geography](#)
- [Glossaries, General](#)
- [Glossary, Ham](#)
- [Global Position Sys](#)
- [GMRS](#)
- [GMT Time](#)
- [Graphics, Ham](#)
- [Gray Line Mapping](#)
- [Great Circle Formula](#)
- [Great Circle Map](#)
- [Grid Squares](#)
- [Grounding](#)
- [GTOR](#)
- [_____](#)
- [Ham Chat Channel](#)
- [Ham Domain -Your Own](#)
- [HamFests](#)
- [Ham Help](#)
- [Hams on Internet](#)
- [Ham, Origin Of](#)
- [Ham,Populations](#)
- [Ham Radios, Mfgs](#)
- [Ham Stores](#)
- [Ham Web Sites](#)
- [HandiHams 4 HandiCapped](#)
- [Hats, Ham](#)
- [Headphones, Dealers](#)
- [HF Nets, On-The-Air](#)
- [HF Packet](#)
- [History, BC Radio & TV](#)
- [History, Call Signs](#)
- [History, Ham Radio](#)
- [Home Brew](#)
- [Humor](#)
- [Hurricanes!!](#)
- [_____](#)
- [IARU](#)
- [IC Mfgs](#)
- [ICOM Links](#)
- [ILINK](#)
- [Insurance, Equipment](#)
- [Interference Book](#)
- [Intermodulation](#)
- [Internet Repeaters IRLP](#)
- [R - Codes](#)
- [RACES](#)
- [Reciprocal Licenses](#)
- [Radios, Antique](#)
- [Radio, Control](#)
- [Radio, Dealers](#)
- [Radio, Stores](#)
- [Radiograms, ARRL](#)
- [Radio,History](#)
- [Radio, Mfg](#)
- [Radio Mods](#)
- [Radios, On-Line](#)
- [Radios, Photos](#)
- [Radio, Repair](#)
- [Radios, Reviews](#)
- [Radio Schematics](#)
- [Radio Specs](#)
- [Radio Stores](#)
- [Radio Stores San Diego](#)
- [Radios, Web Controlled](#)
- [Reflectors,Mail](#)
- [Repair, Radio, Repeater, Rotor](#)
- [Repeater Band Plans](#)
- [Repeater Guides -USA](#)
- [Repeater Guides -World](#)
- [Repeater Hardware](#)
- [Repeaters, Internet](#)
- [Repeater Tech Info](#)
- [Repeaters, 10M/FM](#)
- [Restoration, Radio](#)
- [Rettysnitch](#)
- [Reviews, Products](#)
- [RFI](#)
- [RF Safety](#)
- [Rotor, Repair](#)
- [RSGB Home Page](#)
- [RST System](#)
- [RTTY Operation](#)
- [RTTY, Press](#)
- [_____](#)
- [SAN DIEGO HAM GUIDE](#)
- [San Diego Boating](#)
- [San Diego Ham Clubs](#)
- [San Diego Radio Stores](#)
- [San Diego Tourism](#)

- [Auctions, E-Bay](#)
- [Aurora](#)
- [Awards](#)
- [AX.25](#)
- _____
- [Bandpass Filters](#)
- [Band Plans](#)
- [Band Threats](#)
- [Batteries, Theory](#)
- [Batteries, Vendors](#)
- [BBS's](#)
- [Beacons](#)
- [Beacon Programs](#)
- [Beam Headings](#)
- [Beverage Antennas](#)
- [Bicycle,Ham](#)
- [Blind Hams](#)
- [Boat Anchors](#)
- [Books & Publs](#)
- [Bootleggers](#)
- [BuckMaster QSL](#)
- [Bulletins, ARRL](#)
- [Bulletins, Ham & DX](#)
- [Bureaus, ARRL](#)
- [Bureaus, QSL](#)
- [Bureaus,WW](#)
- _____
- [CAD Programs](#)
- [Callbooks, 4 Sale](#)
- [Callbooks, Web](#)
- [Calling Frequencies](#)
- [Call Sign, Funny](#)
- [Call Sign, History](#)
- [Call Sign, USA](#)
- [Call Sign, Vanity](#)
- [Call Sign, 1x1](#)
- [CAP, Civil Air Patrol](#)
- [CB Radio](#)
- [CC&R Restrictions](#)
- [CEPT Agreement](#)
- [Chat Channel, DX](#)
- [Chat Channel/Forums](#)
- [Circuit Boards](#)
- [Classifieds, Ham](#)
- [Clear Channel AM](#)
- [ClipArt, Ham](#)
- [IOTA](#)
- [Islands](#)
- [IRC's](#)
- [ITU Zones](#)
- _____
- [Jamboree On The Air \(JOTA\)](#)
- [J Pole](#)
- [Japanese Morse](#)
- [Jargon](#)
- _____
- [Keplerian Data](#)
- [Keys Telegraph](#)
- [Keys, Mfgs](#)
- [Kits-Projects](#)
- _____
- [Language Translation](#)
- [Laser,Projects](#)
- [Leagues & Clubs](#)
- [Licenses Abroad](#)
- [License, Obtaining](#)
- [License Plates, Auto](#)
- [License Preparation](#)
- [License Renewal - ARRL](#)
- [License Renewal - FCC](#)
- [Lightning Protect](#)
- [Linux 4 Hams](#)
- [Logging Prog](#)
- [Longitude & Latitude](#)
- _____
- [MAC SoftWare](#)
- [MAC HardWare](#)
- [Magazines, Ham](#)
- [Maidenhead Grid Sys](#)
- [Mailing Lists](#)
- [Manuals,Radio](#)
- [Manuals,Test Equip](#)
- [Manufacturers/Dealers](#)
- [Maps](#)
- [Maritime, CW](#)
- [Maritime Nets](#)
- [Maritime Operation](#)
- [MARS Freq & Pages](#)
- [Meteor Scatter](#)
- [Metric System](#)
- [Mexico Recip License](#)
- [Microphones, Dealers](#)
- [S - Codes](#)
- [SAREX](#)
- [Satellites](#)
- [Scanners & Freq's](#)
- [Schematics, Radio](#)
- [Scouts Radio](#)
- [SETI](#)
- [Shortwave](#)
- [Shuttle Freq](#)
- [Simplex Freqs](#)
- [Slims](#)
- [Societies, Radio](#)
- [Software](#)
- [Solar Cycle 23](#)
- [Solar ~ History](#)
- [Solar Flux Info](#)
- [Solar Power](#)
- [Soldering Tips](#)
- [Special Event Sta](#)
- [Spread Spectrum](#)
- [SSTV](#)
- [Stamps, Ham](#)
- [Stealth Antennas](#)
- [Stores, Ham](#)
- [S-Units](#)
- [Sunrise/Sunset](#)
- [Swap Nets](#)
- [Swap Pages](#)
- [Short Wave Bands](#)
- [SWL \(100\) In English](#)
- [SWR](#)
- _____
- [TAPR](#)
- [T-Hunting](#)
- [Technical Data](#)
- [Tee Shirts](#)
- [Telegraph Keys](#)
- [Telephone RFI](#)
- [Teletype, History](#)
- [TelNet, DX Cluster](#)
- [Ten Meter Rpts](#)
- [Ten-Tec Links](#)
- [10/10 International](#)
- [Terminology, Ham](#)
- [Tesla, Nikola](#)
- [Test Equip, Antique](#)

- [Clocks](#)
- [CLOVER](#)
- [Clubs & Leagues](#)
- [Coax Loss](#)
- [Coax, Mfg](#)
- [Coax Types](#)
- [College Ham Clubs](#)
- [Commercial](#)
- [Commodore Pages](#)
- [Component Data](#)
- [Components,Dealers](#)
- [Computer RFI](#)
- [CONTEST PAGES](#)
- [Conventions, Ham](#)
- [County Hunting](#)
- [CQ Magazines](#)
- [CQ Mag Awards](#)
- [CQ, Origin Of](#)
- [CQ VHF Magazine](#)
- [CQ Zones](#)
- [Cryptography](#)
- [Crystal, Mfgs](#)
- [CW Abbreviations](#)
- [CW, Maritime](#)
- [CW Nets](#)
- [CW, Op Aids](#)
- [CW Pages](#)
- [CW Prosigns](#)
- [CW Tidbits](#)
- [CW Trainers](#)
- _____
- [Decibel Conversions](#)
- [Decibel Tutorial](#)
- [Dealers](#)
- [Dictionaries](#)
- [Digital, Modes](#)
- [Disabled Hams](#)
- [Distance/Bearing](#)
- [Districts, USA](#)
- [Districts, Countries](#)
- [DSP](#)
- [DX DX DX All DX Info Is On a Separate Page](#)
- _____
- [EchoLink](#)
- [E-Mail Addresses](#)
- [Microwave](#)
- [Military Radio](#)
- [MIR](#)
- [Mobile HF](#)
- [Modes, Ham](#)
- [Mods,Radio](#)
- [Modulation](#)
- [Morse Aids](#)
- [Morse Characters](#)
- [Morse Code, Learning](#)
- [Morse Mode](#)
- [Morse Pages](#)
- [Morse Software](#)
- [Morse Tidbits](#)
- [Morse Trainers](#)
- [Motorcycle,Ham](#)
- [MUF Charts Via ARRL](#)
- [MURS](#)
- _____
- [National Traffic Sys](#)
- [NAVTEX](#)
- [NCDXF Beacons](#)
- [Nets, On-The-Air](#)
- [News Groups](#)
- [Newsletters,Ham/DX](#)
- [NICAD/NIMH Batteries](#)
- _____
- [Operating Aids](#)
- [Operating Modes](#)
- [Operating Accessories](#)
- [ORIGINS OF:](#)
- [---CQ, DE, HAM, LID](#)
- [---US CALLSIGNS](#)
- [---73, Q-SIGNALS](#)
- [---SOS & MAYDAY](#)
- [---ROGER WILCO](#)
- [---RST Sys & S-Meter](#)
- [---More, More, More](#)
- [Oscilloscope FAQ](#)
- [OS/2 For Hams](#)
- _____
- [Packet Clusters](#)
- [Packet Directory](#)
- [Packet Links](#)
- [Packet Mfg](#)
- [Packet Software](#)
- [Test Equip, New](#)
- [Test Equip, Used](#)
- [Test Equip, Used, Prices](#)
- [3rd Party Agree](#)
- [Theory](#)
- [Time,UTC&Local](#)
- [Time Std Stations](#)
- [Top Band-160M](#)
- [Toroids](#)
- [Tower Installation](#)
- [Towers Mfg](#)
- [Transformers, Dealers](#)
- [Transistors, Dealers](#)
- [Translation, Language](#)
- [Trivia, Ham](#)
- [Troubleshooting](#)
- [Tubes & Testers](#)
- [Tuners, Antenna Projects](#)
- [Tuners, Dealers](#)
- [TVI](#)
- _____
- [UK Links, 850+](#)
- [Units of Measure](#)
- [Universal Licensing Sys](#)
- [USA/VE pages](#)
- [Use Groups](#)
- [Used Gear, Swap](#)
- [Used Gear, Prices](#)
- [Used Gear, Reviews](#)
- [Used Gear, Specs](#)
- [User Nets](#)
- [UTC/GMT/Time](#)
- _____
- [Vacuum Tubes/Theory](#)
- [Vacuum Tubes/Vendors](#)
- [Vanity Call Apply](#)
- [Vanity Calls Avail](#)
- [VEC's](#)
- [VHF Pages](#)
- [Visually Impaired](#)
- [VSWR](#)
- [VSWR, Meters](#)
- _____
- [Wattmeters, Mfgs](#)
- [Weather \(The WX\)](#)
- [Web Pages, Popular](#)

- [E-Mail via amsat.org](#)
- [E-Mail via arrl.net](#)
- [Earthquakes~..!!](#)
- [Electronic Theory](#)
- [Elmers](#)
- [EME](#)
- [Emergency Freq](#)
- [Emergency Nets](#)
- [Emergency News](#)
- [Emergency Pages](#)
- [Exams, Ham](#)
- [Exam Locations](#)
- _____
- [Family Radio Service](#)
- [Famous Hams](#)
- [FAQs](#)
- [FAX](#)
- [FCC Home Page](#)
- [FCC Forms](#)
- [FCC Rules](#)
- [FCC Search Engine](#)
- [Ferrites](#)
- [Field Day](#)
- [Forums, Ham & DX](#)
- [Fox Hunting](#)
- [Frequencies, BandPlans](#)
- [Frequencies, Calling](#)
- [Frequencies, DC - Daylight](#)
- [Frequencies, Emergency](#)
- [Frequencies, Maritime](#)
- [Frequency Modulation](#)
- [Frequencies, Shortwave](#)
- [Frequencies, Simplex](#)
- [FTP Sites](#)

[BACK TO TOP OF INDEX](#)

- [Packet Tutorial](#)
- [PACTOR](#)
- [Palm/Ham Software](#)
- [PARC ARC San Diego](#)
- [Part 97](#)
- [Parts, Dealers](#)
- [Phone Alphabets](#)
- [PL Freq & Codes](#)
- [Populations, Ham](#)
- [Postal Rates](#)
- [Postage, Return](#)
- [Power Supplies, Mfgs](#)
- [Prefixes](#)
- [Products, Reviews](#)
- [Propagation](#)
- [Propagation Software](#)
- [ProSigns](#)
- [PSK31](#)
- [Publications](#)
- _____
- [Q-Signals](#)
- [QuarterCenturyWirelessAsn](#)
- [QEX Files](#)
- [QRP Calling Freq](#)
- [QRP Contests](#)
- [QRP Kits](#)
- [QRP Operation](#)
- [QRP Projects](#)
- [QSL Bureaus](#)
- [QSL Card Creators](#)
- [QSL Card Management Sys](#)
- [QSL Card Printers](#)
- [QSL Gallery](#)
- [QSL Lookup](#)
- [QSLing, Tips & Advice](#)
- [QSO Parties, State](#)

[BACK TO TOP OF INDEX](#)

- [WEFAX](#)
- [WIRES II](#)
- [Wouff-Hong](#)
- [W1AW](#)
- [WWV Information](#)
- [WWVB Information](#)
- [WWV SFI, A/K](#)
- _____
- [Xtal Radios](#)
- _____
- [Yagi CAD](#)
- [Yaesu Links](#)
- [YL Clubs](#)
- [YL Nets](#)
- [Youth Radio](#)
- _____
- [Z-Signals](#)
- [Zip Codes](#)
- [Zones, Atlas](#)
- [Zones, CQ](#)
- [Zones, ITU](#)
- [Zulu Time](#)
- _____
- [1 X 1 Callsigns](#)
- [1X2 Vanity Avail](#)
- [2X1 Vanity Avail](#)
- [6 Meter Info](#)
- [10 Meter Rpts](#)
- [10-10 International](#)
- [10-Codes](#)
- [50KW AM Stations](#)
- [160M Band](#)

[BACK TO TOP OF INDEX](#)

Hark! I Have Hurl'd My Words To The Far Reaches Of The Earth! What King Of Old Could Do Thus? ---

© AC6V

One May Know Of The Whole World Without Leaving The Shelter Of Their Own Home -- Lao-Tse - 500

BC

73 THANKS FOR STOPPING BY
Counter Stats Thru December 2003 -- 7,865,249 Since 1997 -- Our 7th Year On The Web
Average 3,078 visitors per day
From Over 127 Countries



KUDOS FROM THE READERS

AC6V E-Mail Address

CLICK HERE



CLICK HERE

HELP SUPPORT



THE AC6V WEB SITE

BUY FROM AMAZON.COM - CLICK ON LOGO

AC6V's

Amateur Radio Links

Except where author credit is given, all rights are reserved including menus, files, web pages and HTML source code.

Copyright © 1998 by Rod Dinkins - AC6V



This Page Last Updated: September 06, 2004 All Links Checked - September 03, 2004

ALL LINKS ARE CHECKED MONTHLY

AC6V Amateur Radio And DX Reference Guide

The Gateway To Amateur Radio

The No Fluff, No Banner, Master Index



Check Here If You Want To Open Links In A New Window

 **CHOOSE YOUR AREA OF INTEREST** 

The Most Popular Pages

Check Here If You Want To Open Links In A New Window

| | | |
|--|---|--|
| 1. MASTER INDEX | 11. ANTENNA SOFTWARE | 21. KITS |
| 2. ANTENNA PROJECTS | 12. SWAP SITES | 22. PROPAGATION |
| 3. SOFTWARE | 13. LOGGING | 23. CALLING FREQS |
| 4. TECH REFERENCE | 14. HAM STORES | 24. HF NETS |
| 5. MANUALS | 15. OPERATING MODES | 25. HAM HISTORY |
| 6. FREQ/BAND PLANS | 16. REPEATER GUIDES ECHOLINK | 26. DEALERS,MFG,STORES |
| 7. SWL/SCANNER/BC | 17. PREFIXES | 27. HAM HELP |
| 8. ANTENNA DEALERS | 18. BOATANCHORS/ANTIQUE | 28. CONTEST PAGES |
| 9. HOMEBREW | 19. OPERATING AIDS | 29. DX PAGES & DXPEDITIONS |
| 10. MORSEAIDS * PROGRAMS | 20. CALLBOOKS & QSL | 30. PRODUCT REVIEWS |
| ▶ SAN DIEGO HAM GUIDE | ▶ UTC TIME ▶ PDT TIME | ▶ AC6V BRAG TAPE |

| | | |
|-------------------------------------|---------------------------------------|--|
| ▶ SAN DIEGO TOURISM | ▶ SFI A & K INDEX | ▶ AC6V HUMOR  |
| ▶ LATEST HAM NEWS | ▶ QUICK INDEX | ▶ AC6V BOOKS  |

SEARCH THE AC6V SITE
 IF YOU KNOW HOW – CLICK [HERE](#)
 FOR SEARCH INSTRUCTIONS - CLICK [HERE](#)

THE GATEWAY INDEX TO AMATEUR RADIO 
[A](#) [B](#) [C](#) [D](#) [E](#) [F](#) [G](#) [H](#) [I](#) [J](#) [K](#) [L](#) [M](#) [N](#) [O](#) [P](#) [Q](#) [R](#) [S](#) [T](#) [U](#) [V](#) [W](#) [X](#) [Y](#) [Z](#) [0-9](#)

[Check Here If You Want To Open Links In A New Window](#)

- | | | |
|--|--|--|
| <ul style="list-style-type: none"> ● Abbreviations, CW ● Abbreviations, Ham ● Accessories, TechRef ● Accessories, Manufacturers ● Acronyms ● Alias For E-Mail ● Alphabets/Phonetic ● Amateur's Code Of Conduct ● Amateur Web Sites ● AM Broadcast Stations ● AM'ers ● Amplifiers,Mfg ● Amplifier Reviews ● Amplifier,Theory ● AMSAT ● amsat.org e-mail ● AMTOR ● Antenna Analyzers ● Discussions ● Manufacturers | <ul style="list-style-type: none"> ● GeoClock ● Geography ● Glossaries, General ● Glossary, Ham ● Global Position Sys ● GMRS ● GMT Time ● Graphics, Ham ● Gray Line Mapping ● Great Circle Formula ● Great Circle Map ● Grid Squares ● Grounding ● GTOR ● Ham Chat Channel ● Ham Domain -Your Own ● HamFests ● Ham Help ● Hams on Internet ● Ham, Origin Of ● Ham,Populations | <ul style="list-style-type: none"> ● R - Codes ● RACES ● Reciprocal Licenses ● Radios, Antique ● Radio, Control ● Radio, Dealers ● Radio, Stores ● Radiograms, ARRL ● Radio,History ● Radio, Mfg ● Radio Mods ● Radios, On-Line ● Radios, Photos ● Radio, Repair ● Radios, Reviews ● Radio Schematics ● Radio Specs ● Radio Stores ● Radio Stores San Diego ● Radios, Web Controlled |
|--|--|--|

- [Antenna CC&Rs](#)
- [Antennas,Mfg](#)
- [Antennas,Projects](#)
- [Antenna Reviews](#)
- [Antenna Software](#)
- [Antennas, Stealth](#)
- [Antenna Theory](#)
- [Antique Radios](#)
- [Antique Wireless](#)
- [APRS](#)
- [Area Codes](#)
- [ARES](#)
- [ARRL Awards](#)
- [ARRL Home Page](#)
- [ARRL Index](#)
- [ARRL Logos](#)
- [ARRL Mail Lists](#)
- [ARRL E-Mail Alias](#)
- [ARRL Sections](#)
- [ARRL Sect, Abbrev](#)
- [Astronauts/Sarex Calls](#)
- [Astronomy, Radio](#)
- [Attenuator Design](#)
- [Atlas, Ham](#)
- [ATV](#)
- [Auctions, E-Bay](#)
- [Aurora](#)
- [Awards](#)
- [AX.25](#)
- _____
- [Bandpass Filters](#)
- [Band Plans](#)
- [Band Threats](#)
- [Batteries, Theory](#)
- [Batteries, Vendors](#)
- [BBS's](#)
- [Beacons](#)
- [Beacon Programs](#)
- [Beam Headings](#)
- [Ham Radios, Mfgs](#)
- [Ham Stores](#)
- [Ham Web Sites](#)
- [HandiHams 4 HandiCapped](#)
- [Hats, Ham](#)
- [Headphones, Dealers](#)
- [HF Nets, On-The-Air](#)
- [HF Packet](#)
- [History, BC Radio & TV](#)
- [History, Call Signs](#)
- [History, Ham Radio](#)
- [Home Brew](#)
- [Humor](#)
- [Hurricanes!!](#)
- _____
- [IARU](#)
- [IC Mfgs](#)
- [ICOM Links](#)
- [ILINK](#)
- [Insurance, Equipment](#)
- [Interference Book](#)
- [Intermodulation](#)
- [Internet Repeaters IRLP](#)
- [IOTA](#)
- [Islands](#)
- [IRC's](#)
- [ITU Zones](#)
- _____
- [Jamboree On The Air \(JOTA\)](#)
- [J Pole](#)
- [Japanese Morse](#)
- [Jargon](#)
- _____
- [Keplerian Data](#)
- [Keys Telegraph](#)
- [Keys, Mfgs](#)
- [Kits-Projects](#)
- _____
- [Language Translation](#)
- [Reflectors,Mail](#)
- [Repair, Radio,](#)
- [Repeater, Rotor](#)
- [Repeater Band Plans](#)
- [Repeater Guides - USA](#)
- [Repeater Guides - World](#)
- [Repeater Hardware](#)
- [Repeaters, Internet](#)
- [Repeater Tech Info](#)
- [Repeaters, 10M/FM](#)
- [Restoration, Radio](#)
- [Rettysnitch](#)
- [Reviews, Products](#)
- [RFI](#)
- [RF Safety](#)
- [Rotor, Repair](#)
- [RSGB Home Page](#)
- [RST System](#)
- [RTTY Operation](#)
- [RTTY, Press](#)
- _____
- [SAN DIEGO HAM GUIDE](#)
- [San Diego Boating](#)
- [San Diego Ham Clubs](#)
- [San Diego Radio Stores](#)
- [San Diego Tourism](#)
- [S - Codes](#)
- [SAREX](#)
- [Satellites](#)
- [Scanners & Freq's](#)
- [Schematics, Radio](#)
- [Scouts Radio](#)
- [SETI](#)
- [Shortwave](#)

- [Beverage Antennas](#)
- [Bicycle,Ham](#)
- [Blind Hams](#)
- [Boat Anchors](#)
- [Books & Pubs](#)
- [Bootleggers](#)
- [BuckMaster QSL](#)
- [Bulletins, ARRL](#)
- [Bulletins, Ham & DX](#)
- [Bureaus, ARRL](#)
- [Bureaus, QSL](#)
- [Bureaus,WW](#)
- _____
- [CAD Programs](#)
- [Callbooks, 4 Sale](#)
- [Callbooks, Web](#)
- [Calling Frequencies](#)
- [Call Sign, Funny](#)
- [Call Sign, History](#)
- [Call Sign, USA](#)
- [Call Sign, Vanity](#)
- [Call Sign, 1x1](#)
- [CAP, Civil Air Patrol](#)
- [CB Radio](#)
- [CC&R Restrictions](#)
- [CEPT Agreement](#)
- [Chat Channel, DX](#)
- [Chat Channel/Forums](#)
- [Circuit Boards](#)
- [Classifieds, Ham](#)
- [Clear Channel AM](#)
- [ClipArt, Ham](#)
- [Clocks](#)
- [CLOVER](#)
- [Clubs & Leagues](#)
- [Coax Loss](#)
- [Coax, Mfg](#)
- [Coax Types](#)
- [College Ham Clubs](#)
- [Laser,Projects](#)
- [Leagues & Clubs](#)
- [Licenses Abroad](#)
- [License, Obtaining](#)
- [License Plates, Auto](#)
- [License Preparation](#)
- [License Renewal - ARRL](#)
- [License Renewal - FCC](#)
- [Lightning Protect](#)
- [Linux 4 Hams](#)
- [Logging Prog](#)
- [Longitude & Latitude](#)
- _____
- [MAC SoftWare](#)
- [MAC HardWare](#)
- [Magazines, Ham](#)
- [Maidenhead Grid Sys](#)
- [Mailing Lists](#)
- [Manuals,Radio](#)
- [Manuals,Test Equip](#)
- [Manufacturers/Dealers](#)
- [Maps](#)
- [Maritime, CW](#)
- [Maritime Nets](#)
- [Maritime Operation](#)
- [MARS Freq & Pages](#)
- [Meteor Scatter](#)
- [Metric System](#)
- [Mexico Recip License](#)
- [Microphones, Dealers](#)
- [Microwave](#)
- [Military Radio](#)
- [MIR](#)
- [Mobile HF](#)
- [Modes, Ham](#)
- [Mods,Radio](#)
- [Modulation](#)
- [Morse Aids](#)
- [Morse Characters](#)
- [Shuttle Freq](#)
- [Simplex Freqs](#)
- [Slims](#)
- [Societies,Radio](#)
- [Software](#)
- [Solar Cycle 23](#)
- [Solar ~ History](#)
- [Solar Flux Info](#)
- [Solar Power](#)
- [Soldering Tips](#)
- [Special Event Sta](#)
- [Spread Spectrum](#)
- [SSTV](#)
- [Stamps, Ham](#)
- [Stealth Antennas](#)
- [Stores, Ham](#)
- [S-Units](#)
- [Sunrise/Sunset](#)
- [Swap Nets](#)
- [Swap Pages](#)
- [Short Wave Bands](#)
- [SWL \(100\) In English](#)
- [SWR](#)
- _____
- [TAPR](#)
- [T-Hunting](#)
- [Technical Data](#)
- [Tee Shirts](#)
- [Telegraph Keys](#)
- [Telephone RFI](#)
- [Teletype, History](#)
- [TelNet, DX Cluster](#)
- [Ten Meter Rpts](#)
- [Ten-Tec Links](#)
- [10/10 International](#)
- [Terminology, Ham](#)
- [Tesla, Nikola](#)

- [Commercial](#)
- [Commodore Pages](#)
- [Component Data](#)
- [Components,Dealers](#)
- [Computer RFI](#)
- [CONTEST PAGES](#)
- [Conventions, Ham](#)
- [County Hunting](#)
- [CQ Magazines](#)
- [CQ Mag Awards](#)
- [CQ, Origin Of](#)
- [CQ VHF Magazine](#)
- [CQ Zones](#)
- [Cryptography](#)
- [Crystal, Mfgs](#)
- [CW Abbreviations](#)
- [CW, Maritime](#)
- [CW Nets](#)
- [CW, Op Aids](#)
- [CW Pages](#)
- [CW Prosigns](#)
- [CW Tidbits](#)
- [CW Trainers](#)
- [_____](#)
- [Decibel Conversions](#)
- [Decibel Tutorial](#)
- [Dealers](#)
- [Dictionaries](#)
- [Digital, Modes](#)
- [Disabled Hams](#)
- [Distance/Bearing](#)
- [Districts, USA](#)
- [Districts, Countries](#)
- [DSP](#)
- [DX DX DX All DX
Info Is On a Separate
Page](#)
- [_____](#)
- [EchoLink](#)
- [Morse Code, Learning](#)
- [Morse Mode](#)
- [Morse Pages](#)
- [Morse Software](#)
- [Morse Tidbits](#)
- [Morse Trainers](#)
- [Motorcycle,Ham](#)
- [MUF Charts Via ARRL](#)
- [MURS](#)
- [_____](#)
- [National Traffic Sys](#)
- [NAVTEX](#)
- [NCDXF Beacons](#)
- [Nets, On-The-Air](#)
- [News Groups](#)
- [Newsletters,Ham/DX](#)
- [NICAD/NIMH Batteries](#)
- [_____](#)
- [Operating Aids](#)
- [Operating Modes](#)
- [Operating Accessories](#)
- [ORIGINS OF:
---CQ, DE, HAM, LID](#)
- [---US CALLSIGNS](#)
- [---73, Q-SIGNALS](#)
- [---SOS & MAYDAY](#)
- [---ROGER WILCO](#)
- [---RST Sys & S-Meter](#)
- [---More, More, More](#)
- [Oscilloscope FAQ](#)
- [OS/2 For Hams](#)
- [_____](#)
- [Packet Clusters](#)
- [Packet Directory](#)
- [Packet Links](#)
- [Packet Mfg](#)
- [Packet Software](#)
- [Packet Tutorial](#)
- [PACTOR](#)
- [_____](#)
- [Test Equip, Antique](#)
- [Test Equip, New](#)
- [Test Equip, Used](#)
- [Test Equip, Used,
Prices](#)
- [3rd Party Agree](#)
- [Theory](#)
- [Time,UTC&Local](#)
- [Time Std Stations](#)
- [Top Band-160M](#)
- [Toroids](#)
- [Tower Installation](#)
- [Towers Mfg](#)
- [Transformers,
Dealers](#)
- [Transistors, Dealers](#)
- [Translation,
Language](#)
- [Trivia, Ham](#)
- [Troubleshooting](#)
- [Tubes & Testers](#)
- [Tuners, Antenna
Projects](#)
- [Tuners, Dealers](#)
- [TVI](#)
- [_____](#)
- [UK Links, 850+](#)
- [Units of Measure](#)
- [Universal Licensing
Sys](#)
- [USA/VE pages](#)
- [Use Groups](#)
- [Used Gear, Swap](#)
- [Used Gear, Prices](#)
- [Used Gear, Reviews](#)
- [Used Gear, Specs](#)
- [User Nets](#)
- [UTC/GMT/Time](#)
- [_____](#)

- [E-Mail Addresses](#)
- [E-Mail via amsat.org](#)
- [E-Mail via arrl.net](#)
- [Earthquakes~~..!!](#)
- [Electronic Theory](#)
- [Elmers](#)
- [EME](#)
- [Emergency Freq](#)
- [Emergency Nets](#)
- [Emergency News](#)
- [Emergency Pages](#)
- [Exams, Ham](#)
- [Exam Locations](#)
- _____
- [Family Radio Service](#)
- [Famous Hams](#)
- [FAQs](#)
- [FAX](#)
- [FCC Home Page](#)
- [FCC Forms](#)
- [FCC Rules](#)
- [FCC Search Engine](#)
- [Ferrites](#)
- [Field Day](#)
- [Forums, Ham & DX](#)
- [Fox Hunting](#)
- [Frequencies, BandPlans](#)
- [Frequencies, Calling](#)
- [Frequencies, DC - Daylight](#)
- [Frequencies, Emergency](#)
- [Frequencies, Maritime](#)
- [Frequency Modulation](#)
- [Frequencies, Shortwave](#)
- [Frequencies, Simplex](#)
- [FTP Sites](#)
- [Palm/Ham Software](#)
- [PARC ARC San Diego](#)
- [Part 97](#)
- [Parts, Dealers](#)
- [Phone Alphabets](#)
- [PL Freq & Codes](#)
- [Populations, Ham](#)
- [Postal Rates](#)
- [Postage, Return](#)
- [Power Supplies, Mfgs](#)
- [Prefixes](#)
- [Products, Reviews](#)
- [Propagation](#)
- [Propagation Software](#)
- [ProSigns](#)
- [PSK31](#)
- [Publications](#)
- _____
- [Q-Signals](#)
- [QuarterCenturyWirelessAsn](#)
- [QEX Files](#)
- [QRP Calling Freq](#)
- [QRP Contests](#)
- [QRP Kits](#)
- [QRP Operation](#)
- [QRP Projects](#)
- [QSL Bureaus](#)
- [QSL Card Creators](#)
- [QSL Card Management Sys](#)
- [QSL Card Printers](#)
- [QSL Gallery](#)
- [QSL Lookup](#)
- [QSLing, Tips & Advice](#)
- [QSO Parties, State](#)
- _____
- [Vacuum Tubes/Theory](#)
- [Vacuum Tubes/Vendors](#)
- [Vanity Call Apply](#)
- [Vanity Calls Avail](#)
- [VEC's](#)
- [VHF Pages](#)
- [Visually Impaired](#)
- [VSWR](#)
- [VSWR, Meters](#)
- _____
- [Wattmeters, Mfgs](#)
- [Weather \(The WX\)](#)
- [Web Pages, Popular](#)
- [WEFAX](#)
- [WIRES II](#)
- [Wouff-Hong](#)
- [W1AW](#)
- [WWV Information](#)
- [WWVB Information](#)
- [WWV SFI, A/K](#)
- _____
- [Xtal Radios](#)
- _____
- [Yagi CAD](#)
- [Yaesu Links](#)
- [YL Clubs](#)
- [YL Nets](#)
- [Youth Radio](#)
- _____
- [Z-Signals](#)
- [Zip Codes](#)
- [Zones, Atlas](#)
- [Zones, CQ](#)
- [Zones, ITU](#)
- [Zulu Time](#)
- _____
- [1 X 1 Callsigns](#)

[BACK TO TOP OF INDEX](#)

[BACK TO TOP OF INDEX](#)

- [1X2 Vanity Avail](#)
- [2X1 Vanity Avail](#)
- [6 Meter Info](#)
- [10 Meter Rpts](#)
- [10-10 International](#)
- [10-Codes](#)
- [50KW AM Stations](#)
- [160M Band](#)

[BACK TO TOP OF INDEX](#)

**Hark! I Have Hurlled My Words To The Far Reaches Of The Earth! What King Of Old Could Do Thus? --- ©
AC6V**

One May Know Of The Whole World Without Leaving The Shelter Of Their Own Home -- Lao-Tse - 500 BC

**73 THANKS FOR STOPPING BY
Counter Stats Thru December 2003 -- 5,719,404 Since 1997 -- Our 7th Year On The Web
Average 3,078 visitors per day
From Over 127 Countries**

This Page Last Updated: August 23, 2004 All Links Checked - December 7, 2003

AC6V E-Mail Address

CLICK HERE



CLICK HERE

**Except where author credit is given, all rights are reserved including menus, files, web pages and
HTML source code.**

Copyright © 1998 by Rod Dinkins - AC6V

[GOTO THE AC6V MAIN PAGE](#)

Check Here If You Want To Open Links In A New Window

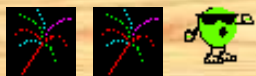

THE AC6V BRAG TAPE

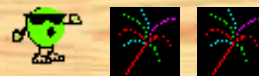

AC6V

Rod Dinkins

4982 Marin Drive

Oceanside, CA 92056-4973 USA, San Diego County

[Click Here For Map](#) Use Zoom Out For Nearby Cities

[E-Mail Address](#)

First Ham Ticket - April 2, 1977

10/10 Number 18029

Grid Square DM13ie, CQ Zone 3, ITU Zone 6

I QSL 100% -- Send Via [eQSL](#) Or [Snail Mail](#) Or [ARRL Bureau](#)

Hi I'm Rod Dinkins living in Oceanside, CA. I started in radio in the late 1940's as an SWL, AM, and Ham band Listener with a Knight Kit OceanHopper - later a Hallicrafters S-40A.

Electronics seemed to be my calling and I had 2 years of vocational electricity and electronics in High School. Four years in the US Navy during the Korean War as an Aviation Electronics Technician - AT1. Also taught electronics at NATTC Memphis, TN - one year.

Four years at Convair Pomona as an instructor of electronics and guided missiles. 2 years as a vocational electronics teacher at the Junior college level in Walnut CA. Achieved an AA degree in Electronics under the GI Bill. Over 30 years as an Electronics Technical Writer with aerospace and Hewlett Packard. Licensed in Amateur Radio since 1977.

Today I am Full Time DXing (retired), writing [Ham Books](#) and enjoy working on my web pages and being as good an Elmer as I can.



**Field Day 2002. 11 Year Old Bryce Kozlowski contacts Australia!
With Assist From AC6V and KG6HBF**



Photo By W6VR



AWARDS GIVEN TO THE AC6V SITE



Click On Award To Go To The Award Site



[CLICK HERE FOR DA SHACK AND DA BIRD](#)

Some Digital Photos with my Olympus D600L

WHY ANOTHER HAM RADIO PAGE???

Just My Way Of Giving Something Back To Ham Radio

73 Rod in San Diego



The Harmonics

[Son Jeff is Programming at Sun Microsystems](#)

[Son Steve Is A Video/Media Engineer At Apple Computers](#)

[Grandson Ewan \(6 years old\) -- Has hit the Big Time Music Scene](#)
[--The Doodle Song -- On line in MP3](#)

[Grand-Daughter Rory \(3-1/2 Years Old\)](#)

The XYL

[Karla is an ER Nurse Extraordinaire at the La Jolla VA Hospital](#)



[ROD AND KARLA COMMANDEER THE DAWN PRINCESS](#)



[K9TZU -- Our New Family Addition](#)



[Our Fine Feathered Friend -- VK1BRD](#)



[Civil War Re-enactment Photos](#)



[AC6V GENEALOGY PAGE](#)

[DINKINS GENEALOGY ON FTW](#)

MY HAM AWARDS -- BRAG BRAG

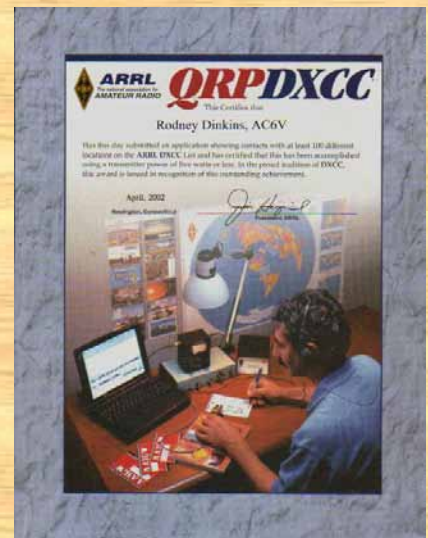
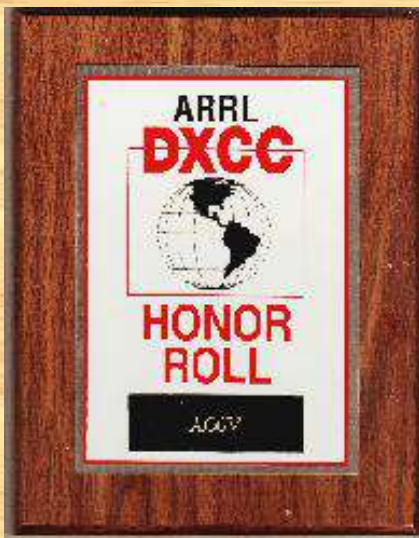

DXCC HONOR ROLL (326 MIXED) ► DXCC QRP (107 MIXED)

► 5Band WAS + WAS 17M + 49 STATES ON 12M (Need Utah)

**► Six Meters - Worked 48 US States and 6 DXCC Countries. 198 Grid Squares (VUCC)
States Needed For WAS 6M - AR and KY.**

► WAZ 10M, 15M, 20M

- DXCC MIXED #18222 ► DXCC PHONE #8758 ► DXCC CW #1682**
- DXCC HONOR ROLL MIXED SEPT 2001 ► DXCC QRP APR 2002**
- 5BAND WAS #421 ► WAS CW #27,120 ► WAS QRP**
- WAZ 10M SSB #118, 15M, 20M**
- WPX #888 ► WAC ► WAVE #985**

- ◆ Current ARRL DXCC Entities- 335**
- ◆ DXCC Mixed - All Time Confirmed + Deleted -- 336 (326 Current)**
- ◆ DXCC Phone - All Time Confirmed + Deleted -- 328 (319 Current)**
- ◆ DXCC CW - All Time Confirmed + Deleted -- 168 (165 Current)**
- ◆ DXCC QRP - All Time Confirmed + Deleted -- 107 (107 Current)**
- ◆ DXCC Band Countries - All Time Confirmed + Deleted -- 1085 (1075) Current)**

DXCC is copyright ARRL and its use here is printed with permission of the ARRL.

- ◆ 1,745 miles per Watt -- Mozambique C9 Wrked QRP**
- ◆ Ten/Ten Number 18029**
- ◆ Grid Square - DM13ie**
- WAN -- Worked All Neighbors**
- WANA -- Worked All Neighbors Again**
- WAB -- Worked All Beacons (-)**
- TORA Award -- Timed Out Repeater Again**

COUNTRIES STILL NEEDED FOR TOP OF THE ROLL (9)

- ◆ 3Y - Bouvet -- Not Even Captain Cook Could Find This One!!**
- ◆ 7O - Yemen - Missed Em**

- ◆ BS7 - Scarborough Grief
- ◆ P5 - No. Korea
- ◆ VK0 - Heard -- I've never even Herd Em
- ◆ VU - Nicobar
- ◆ VU - Laccadive -- Lack this one too!!
- ◆ YA - Afghanistan -- Been Hounding em
- ◆ ZD9 - Tristan da Cunha

COUNTRIES NEEDED FOR DXCC HONOR ROLL PHONE (7)

(Or Any Of The ◆ Above

- ▶ 9U - Burundi
- ▶ BV9P - Pratus Isle
- ▶ E4 - Palenstine
- ▶ FT5W - Crozet Isle
- ▶ FT5Z - Amsterdam Isle
- ▶ VK0 - Macquaire Isle
- ▶ ZC4 - UK Bases-Cyprus



But I am QRO!!!!

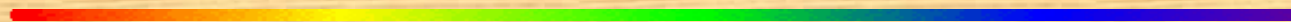

U.S. NAVY SERVICE
Rodney Roy Dinkins
USN 4287963



- **US Navy -AT1 - Aviation Electronics Technician 1951-1955.**
Radio Operator and Avionics Maintenance Technician.
Air Transport Squadrons - VR-8.
Aircraft were Douglas R5D and Lockheed R7V-1 Super Constellations.



US NAVY R7V-1 SUPER CONSTELLATION (Photo Credit - William Henry Davis, K1WD)
Aircraft Above Is A Restored Air Force C-121, Navy Version Is Very Similar

Click below to see more photos of the "Connie"

◆ [The Navy MATS Page](#) -- VR3, VR6, VR7, VR8, VR22 Squadrons

◆ [Lockheed Super Constellation](#) -- Navy R7V-1 -- VR8

◆ [United States Navy C-130 Squadrons - Including VR-8](#)

◆ [Lockheed Super Connie](#) -- The Constellation Group

◆ [The MATS Connie Page](#) -- Restoration Group in Arizona

◆ [Connie In Antarctica](#)

◆ [Blue Angels Super Connie \(C-121\)](#)

◆ [Lockheed Super Constellation Avionics](#) -- APS's, ARC's etc. (Compiled By R. Dinkins)

◆ [Air Force Constellation](#) -- EC-121 (551st and 552nd AEW&C WINGS)

◆ [Lockheed EC-121 Constellation](#)

◆ [The WILLIE VICTOR Roster](#)

▶ **Some Other Navy Aircraft I flew In**

- ◆ [Beech SNB](#) -- For Airborne Radar Training (APS-4 B-Scan Radar!)
- ◆ [Douglas Transport Aircraft](#) -- R4D
- ◆ [Douglas R5D](#) - A Navy MATS Photo Another [Douglas R5D VR-8](#)
- ◆ [Douglas AQ](#) -- Electronic Counter-Measures Variant of the Able Dog (Spad)
- ◆ [Martin Mars JRM-1 \(Mariana's Mars\) Flying Boat](#) -- Two are still flying as firebombers
- ◆ [Lots of History and Personal Accounts of the Martin Mars](#)
- ◆ [Photo Gallery](#) USN Planes & Ships I Worked On Or Flew/Sailed In

AMATEUR RADIO CLUBS



[San Diego DX Club](#)



[ARRL Member](#)



[Palomar ARC](#)



[Northern California DX Club](#) - Former DXer Newsletter Editor



AC6V HUMOR



[Not For The faint Hearted!!](#)

\$ MONEY_MAKIN & JOBS



Sheckle Generation --- Technical Writer - Electronics Instructor



▶ [Full Time DXing](#) -- Mar 1999/Present - May Write A Book or Two!



[See DX101X](#)



[FM101x](#)

▶ [Solar Turbine](#) -- 1998/1999 - Power Turbines - 18,000 Horse Power!!!!

▶ Palomar Products -- P3V Avionics -- 1997

▶ [Cubic](#) -- J-Stars -- 1996

▶ [Hewlett-Packard](#) Santa Clara (21 years) -- Freq & Time, Lasers -- 1969-1990

▶ Sylvania -- Reconnaissance Systems -- 1962-1969

▶ Philco -- AF Tracking Stations -- 1960-1962

▶ Convair -- Terrier, Tartar, Mauler, Redeye -- 1955-1960

▶ US Navy -- 1951 to 1955 Didn't make a lot of money there

▶ Republic Steel -- Electrician -- 1949-1951



RIGS & TOYS



HF/VHF/UHF STUFF

- ▶ Kenwood TS-870SAT ▶ Kenwood TS-570S(G) ▶ Kenwood SM-230
- ▶ Ameritron AL-80B ▶ Kenwood TS-790A ▶ Kenwood TM-261
- ▶ ADI-220 MHz ▶ Icom IC-T2H ▶ Kenwood TH-F6A
- ▶ Bencher Single Paddle Key ▶ LogicKey ▶ Rascal PSK31

ANTENNAS

- ▶ Cushcraft R-7000 ▶ Diamond U5000 ▶ Cushcraft AR6

BOATANCHORS

- ▶ Hallicrafters S-40B ▶ Hallicrafters S-38C ▶ Swan 350 (Three-Drifty!)
- ▶ Kenwood TS-830S ▶ Hallicrafters SX-100

SCANNER/SWL

- ▶ RadioShack Pro 2006 Scanner ▶ Radio Shack DX-398 SWL

FRS

- ▶ Kenwood FRS Radios UBZ-AL14

RAN OUT OF SHECKLES !

● Will think of more to brag on Later!!

   **THE AC6V BRAG PHOTOS**   

HONOR ROLL -- BRAG BRAG



Latest Shack Shot -- 160 Meters To 1.2 Gig (less 900 Mhz)



**Home Made QSL Card Using MS PowerPoint and Printed On Orange Card Stock.
Beam Is NOT Standard Equipment!!**

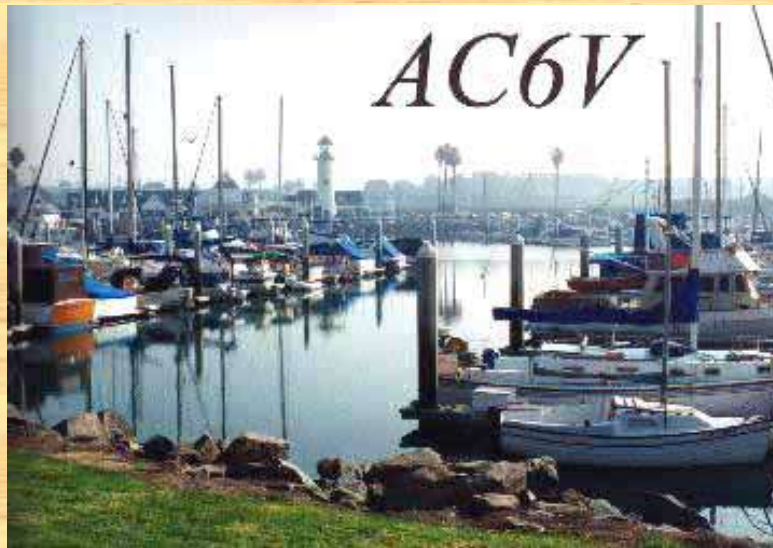

**Photo By AC6V With Pentax ZX-5 35mm Camera. At Oceanside Harbor.
Made With an Avery Transparent Label For AC6V Overlay.
Reverse Side Uses an Avery Label For QSL Info.**



Star Of India At San Diego Maritime Museum
Photo By AC6V With Pentax ZX-5 35mm Camera.
For callsign - made with an Avery Transparent Label #8660.
Reverse side uses an Avery White Label #5263 For QSL Info.
The world's oldest active iron-hull sailing ship, the Star of India was built in 1863.
[Star Of India History 2.](#)

AC6V
OCEANSIDE, CALIFORNIA USA
San Diego County

10-X 18029 DXCC Honor Roll DXCC-QRP 6Band WAS

Rod Dinkins
4982 Marin Drive
Oceanside, CA 92056

Grid Square: DM13ie

| CONFIRMING QSO WITH | | DAY | MONTH | YEAR |
|---------------------|-----|-----|-------|------|
| | | | | |
| UTC | MHz | RST | MODE | |
| | | | | |

PLS QSL ____
TNX QSL ____

www.cheapqsl.com

My Latest QSL Card From [CheapQSLs](#)

[AC6V's](#)
Amateur Radio Links

[GO BACK TO THE BIG INDEX](#)

[AC6V's](#)
Amateur Radio Links

[GO BACK TO THE QUICK INDEX](#)

Last Update: August 04, 2004

Balun and Transformer Core Selection

[[Home](#)] [[Up](#)]

Related articles at

[Balun Test](#) contains model of "perfect" dipole currents.

[Sleeve Balun](#) shows how a sleeve adds impedance, useful for VHF and higher baluns

Receiving [Common Mode Noise](#) shows how lack of a balun can contribute to system noise (it applies to transmitting antennas as well)

[Longwires, Verticals, and Baluns](#) shows how unbalanced antennas can have similar problems

[Transmitting baluns](#) on testing transmitting baluns

Occasionally errors are made regarding core selection. This especially includes baluns, where on occasion some very strange ideas surface. One rather odd but somewhat popular idea is that adding a mixture of core types will allow both high power operation and high choking impedance in baluns by slowly reducing current through a balun. Other misleading claims are that extreme values of core μ , such as values in the 10,000 or higher range, are necessary on 1.8 MHz and higher. Other ideas tend support use of excessively low permeability cores for the same application.

When I recommend a core, the material selection is always based on actual measurements with proper test equipment on a bench as well as in the actual end-application.

Core Material

I mainly use 73 material for receiving applications in **LOW POWER** applications between .1 and 30 MHz. 73 and similar core materials generally minimize the turns count required without inducing excessive loss. One of the best indicators of correct core selection is looking at the turns required. You'll notice most of the transformers I use have only one or two turns for every 100 ohms of impedance. My 75 to 450 ohm Beverage transformers, for example, only require two-turn primary and 5-turn secondary windings. *A low "turns count" is a good indicator the correct core size and*

core material is being used.

For high power applications at HF it is often necessary to use lower permeability cores. There are two reasons for this:

- Lower permeability cores generally are available with higher curie temperatures. They operate at high temperatures without losing their magnetic properties.
- Lower permeability cores have higher Q (lower loss tangent) at a given frequency. This means a larger part of the impedance is associated with *lossless* reactance rather *dissipative* resistance. They turn a smaller percentage of power into heat, and that is very important at high power levels.

Permeability changes with frequency. As frequency is increased from zero eventually core impedance peaks. Above the frequency where impedance peaks the impedance of the core (and the *effective* permeability) actually decreases.

A downward slope in permeability with increasing frequency is useful for controlling impedance in broadband transformers, but we should be careful to avoid excessive slope. Excessive initial permeability can easily move the operating area too far out on the downward slope of impedance.

A transformer or inductor operating on the downward slope of a high μ_i core requires extra turns to maintain critical impedance and often requires more turns than a lower μ_i core. The upper frequency limit will decrease, and this may reduce useful bandwidth in the desired frequency range.

Using excessive initial permeability means winding becomes more tedious (it takes more turns). The wire has to be smaller and more fragile to fit a given core window. Temperature stability is often reduced while losses increase over an optimum core material selection. In addition, stray capacitance increases needlessly, reducing bandwidth and increasing unwanted stray coupling.

Do **NOT** pick cores solely by considering initial μ , since that value is taken at dc. You should consider *characteristics measured at the operating frequency!*

Always remember this general guideline. Less wire length (as long as winding impedance is sufficient) results in better transformer bandwidth. The best designs place maximum conductor length **INSIDE** the magnetic core window, and minimum conductor length **OUTSIDE** the core window.

Heating

At higher power levels, it is necessary to move to lower loss tangent and higher curie

temperature materials like 65, 61, or (in extreme cases) 43 materials. Even a fraction of a dB loss produces significant heating in small cores when power level is in the kilowatt range. *The loss DIFFERENCE in non-resonant applications between lower and high ui ferrite cores isn't significantly different, but heating can be much less!*

We often assume heat means a core is very lossy or is "saturating", but this often isn't true. We must consider the power level, duty cycle, and ability of the core to dissipate heat and look at the full picture.

Very small cores, such as small thin .5 inch diameter cores used on bead-type choke baluns, can only dissipate a fraction of a watt in open air. It sometimes helps to put temperature in perspective by visualizing how hot a 60-watt light bulb runs in normal operation. When we consider the core's size, it usually has significantly less surface area than the bulb. The core also has poor thermal conductivity, and is often stuffed in a container preventing any type of air circulation.

Consider the construction of a typical bead balun, enclosed in PVC and heat shrink tubing. As little as 20 watts dissipated out of 1500 watts can produce damaging heat in tiny beads enclosed in a PVC tube. 20 watts out of 1500 is less than 0.1dB loss, yet it overheats the core!

The problem is almost always a heating problem, and not a core-loss problem. It is almost never core saturation, unless the core is subjected to very low average power and very high peak power levels. It is best that we worry about heat and the number of turns we use, not actual power loss, when selecting a core.

Core Style

Soft-iron cores (soft magnetically) increase inductance because they increase *flux density* near a conductor for a given current. With only a small amount of flux "concentration", there can not be a large increase in inductance or impedance. We need a significant increase in flux to have a significant increase in impedance.

The area outside the core window does NOT have a closed magnetic path surrounding the conductor. *The presence of the core has a minimal effect on impedance of any conductor area outside the core window.* Most of the flux from external wires is in air, rather the core. With only a portion of the flux surrounding the outer conductors cutting the outer layers of the core, the *useful* impedance contribution of wire outside the core window to system impedance is minimal. Conductor length outside the core window mostly adds unwanted stray reactance and leakage flux. If we MINIMIZE the wire length exposed outside the core, and we generally have a more effective inductor, choke, or transformer.

This effect can be easily conformed in a simple experiment using an antenna analyzer. Connect a short wire across the output of an analyzer, and measure the impedance. Lay a core against the wire,

and observe the very small impedance increase. Now pass the same wire through the core center, and observe the large impedance change. This illustrates why the winding's wire length on the outside of the core is wasted, mostly contributing to undesired effects.

Core Dimensions

The area inside the winding-window of a soft-iron (soft magnetically, not physically) core is cut by all of the flux lines, and this area has a very large effect on impedance. The core concentrates the magnetic flux surrounding a current-carrying conductor into a very small area, and the thickness of the core moving away from the area of the conductor very rapidly has less effect.

- The additional impedance caused by placing a core over a conductor or conductors is almost entirely proportional to the core's internal length (window depth) paralleling and surrounding the conductor or conductors.
- The core diameter or radial thickness only has a small effect on impedance.

Doubling the core area **parallel** with a conductor roughly doubles winding impedance. The same is NOT true for an increase in core wall thickness, core thickness barely affects impedance.

I prefer binocular cores for most low-power applications and side-by-side stacks of cores (making a large "binocular core") for high power broad-band applications. This type of core arrangement almost always minimizes the amount of conductor hanging "outside the window". With very little conductor hanging "outside" the core window, there is less "needless" wire adding undesired stray capacitance and series resistance. For a given core material and impedance, conductor length can often be reduced to about one-third of a similar impedance choke (or transformer) using a conventional single-hole core or single stack!

Low Power Measurements

Phase Inversion and Choke Baluns

Some of my receiving system designs use phase-inversion transformers. Phase-inversion transformers are identical to (and interchangeable with) choke baluns or line-isolation transformers. For HF receiving applications, 73-material binocular cores are wound with six passes of #26 twisted-pair enameled wire. I use Fair Rite Products 2873000202 cores (about 1/2 inch square and 1/3 inch thick 73 material).

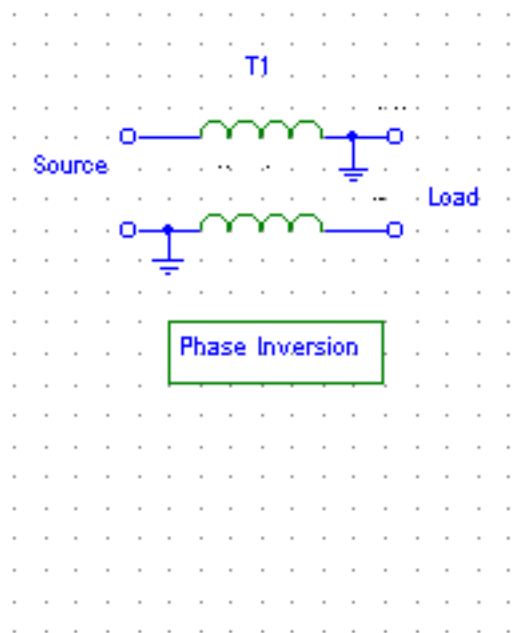

Here are measurements of a sample inversion transformer at 2.5MHz using accurate (and fairly new) commercial equipment:

| Load Value (ohms) | Loss (-dB) | Phase Error (degrees deviation from 180) |
|-------------------|------------|--|
| 100 | ~ 0 | <1 |
| 33 | ~ 0 | -1.2 |
| 10 | 0.2 | -2 |

This shows inverting transformer construction is good, since even a 10-ohm impedance load works well!

Beverage Matching Transformer

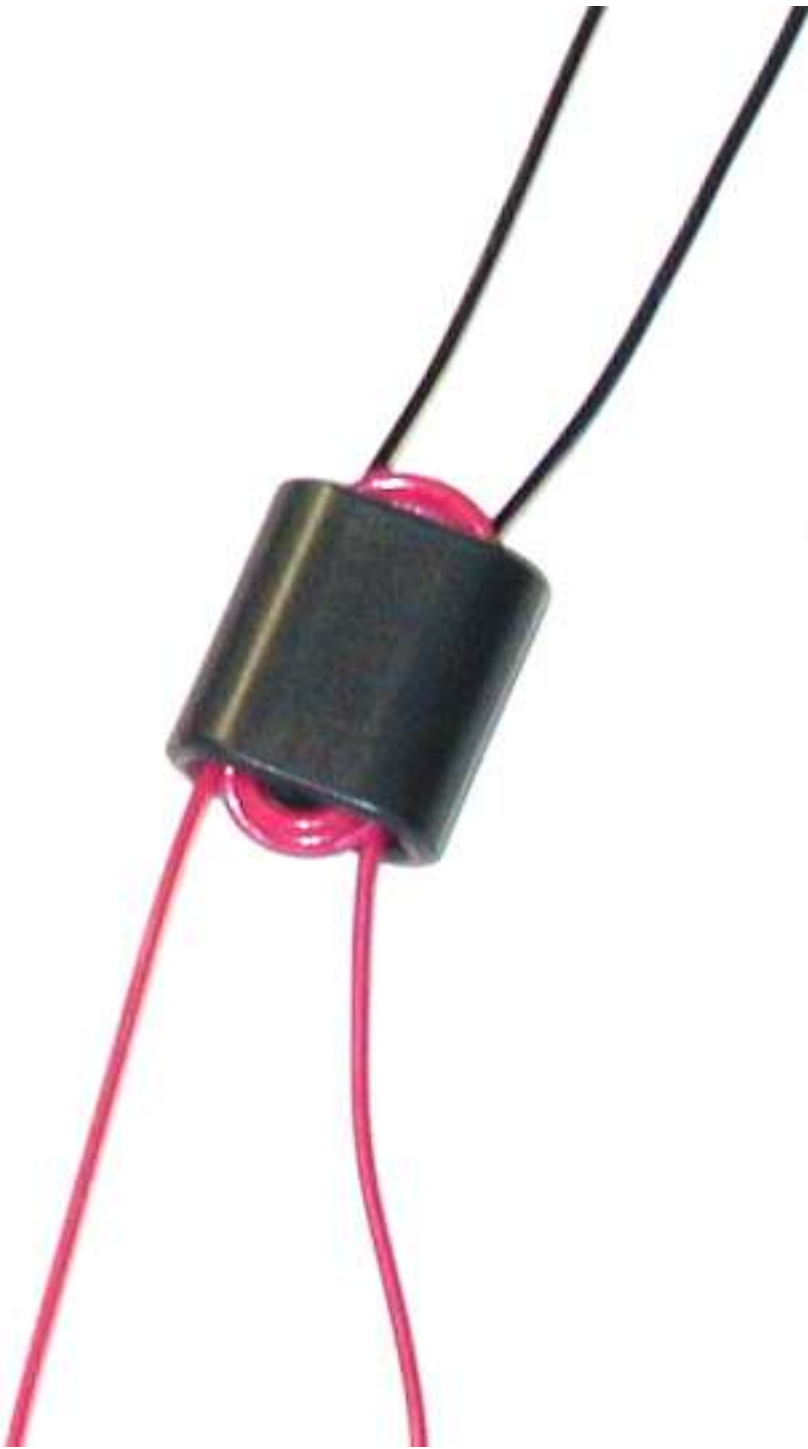

Sometimes I use designs for a long time, and forget how I decided they were OK. I recently received an e-mail questioning the number of turns in my Beverage transformer design, so it seemed like a good time to re-confirm the design.

I retested a 2:5 turn ratio transformer using a single FairRite Products 2873000202 core (about 1/2

inch square and 1/3 inch thick 73 material) two different ways on a generator/ network analyzer/vector impedance test set.

Total loss of two back-to-back transformers was .84dB at 1 MHz increasing, not decreasing, linearly to .98dB at 30MHz. The actual transformer loss would be .42dB at 1MHz increasing to .49dB at 30MHz.

Doubling turns increased the attenuation slope. While 1MHz loss decreased to .69dB per pair, 30MHz loss increased to 1.21dB. This was for a PAIR of transformers connected in series to make a 1:1 transformer. This of course removes mismatch losses, so it is twice the real transformer loss. Actual loss would be .35dB @ 1MHz increasing to .61dB at 30MHz.

Measuring a second way, I terminated the transformer in 470 ohms. Loss measured .65dB at 1MHz when mismatch loss was included. Since receivers have wide ranges of input impedance, any mismatch error might help OR hurt actual system loss. Factoring out mismatch loss the second measurement indicated about .53dB 1MHz loss with the original 2-to-5 turn transformer and .43dB with twice the turns.

Every measurement has tolerances, and the two different methods do provide different losses because measurement errors affect results differently. Still, it is safe to say doubling turns has a negligible effect on 1MHz loss (which is around .45dB).

HF Receiving Loop Antenna

An easy-to-make receiving loop antenna for HF

20m HF Receiving Loop Antenna



Receiving HF signals at my location is a compromise situation due to the antennas I use and the high noise environment in the city. Although my transceiver has good selectivity and excellent filters, I suffer from high noise conditions that at times make receiving a chore. This is true for both weak-signal DX as well as regional chats with friends in the Southwestern US.

I have often wondered whether a loop receiving antenna would be a good solution to my need for better reception but was hesitant to get involved with the typical preamplifiers and monstrous dimensions most of the designs I have seen require. This all changed when I came across a website that described an easy-to-build receiving loop that does not need a preamp. This design does require an external antenna tuner to provide some preselection gain and uses your transceiver's preamp. You simply connect the loop through the feeder to your antenna tuner and feed the tuner into your transceiver's auxiliary antenna input connector. You peak the external tuner for maximum signal strength.

Remember: this is a RECEIVE only antenna - it is not intended for transmitting! If your rig doesn't have an internal antenna switchover relay you will need to exercise caution doing it manually. I built my first loop for 40/80m in order to improve reception of signals in the Southwest and inadvertently transmitted once on 75m. I was heard weakly, 150 miles away -pumping 300 watts into the loop - it didn't damage anything but you don't want to operate this way for long!

I built this loop directly from the greertech.com website dimensions (see below) and added my own wooden

[Home](#)

[K7ZB QSL Card](#)

[A brief K7ZB history...](#)

[K7ZB activities...](#)

[160m DX Contests -
2001/2004](#)

[Jamboree On The Air
2000](#)

[A radio attempt on
Kathmandu...](#)

[An effective 10-20m DX
antenna for deed
restricted lots...](#)

[The 40 meter Stealth
Vertical](#)

[A Stealthy 75 meter
Antenna](#)

**HF Receiving Loop
Antenna**

[Other activities and
photos](#)

[Email K7ZB](#)

support design made from 1/2X3/4 inch stock from Home Depot. I first built the loops and supported them with a simple 1/2 inch PVC pipe mounting system to evaluate them. I liked this antenna so much that the final versions have a simple wood support built into my operating desk for hand rotation. I can remove the entire antenna system in a manner of minutes when I don't want to use the loop.

The photos here show the basic parts and how small the 20m loop really is - each wooden frame piece is 22 inches long. The feeder from the loop to the antenna tuner is 34 inches long, and the loop itself is 5.9 feet in length, per the greertech.com dimensions for RG-58/U coax. If you use a different coax type, make sure you use the appropriate dimensions in the referenced material.

Loop components



I pegged the pieces of the loop support together using dowels so as not to have any metal inside or close to the loop. I made the shorted end of the loop out of an old "blitz bug" lightning arrester which was in my junk box that conveniently has female '259 connectors and a screw hole in the barrel. Make sure you short only the braid to the center conductor to the braid and don't short out the center conductors! You could simplify things and skip the connector altogether - just solder the center conductor to the braid to the shield as greertech.com indicates on his website. My first 40m loop was built this way and it took about 15 minutes to construct.

Notice the very important gap in the shield braid on the side of the loop - this is one of the key features that makes this design work.

See the greertech.com website referenced below for the electrical details and principles of operation - this is an excellent source of information for these simple, constant-current magnetic loop antennas.

Completed 20m HF receiving loop

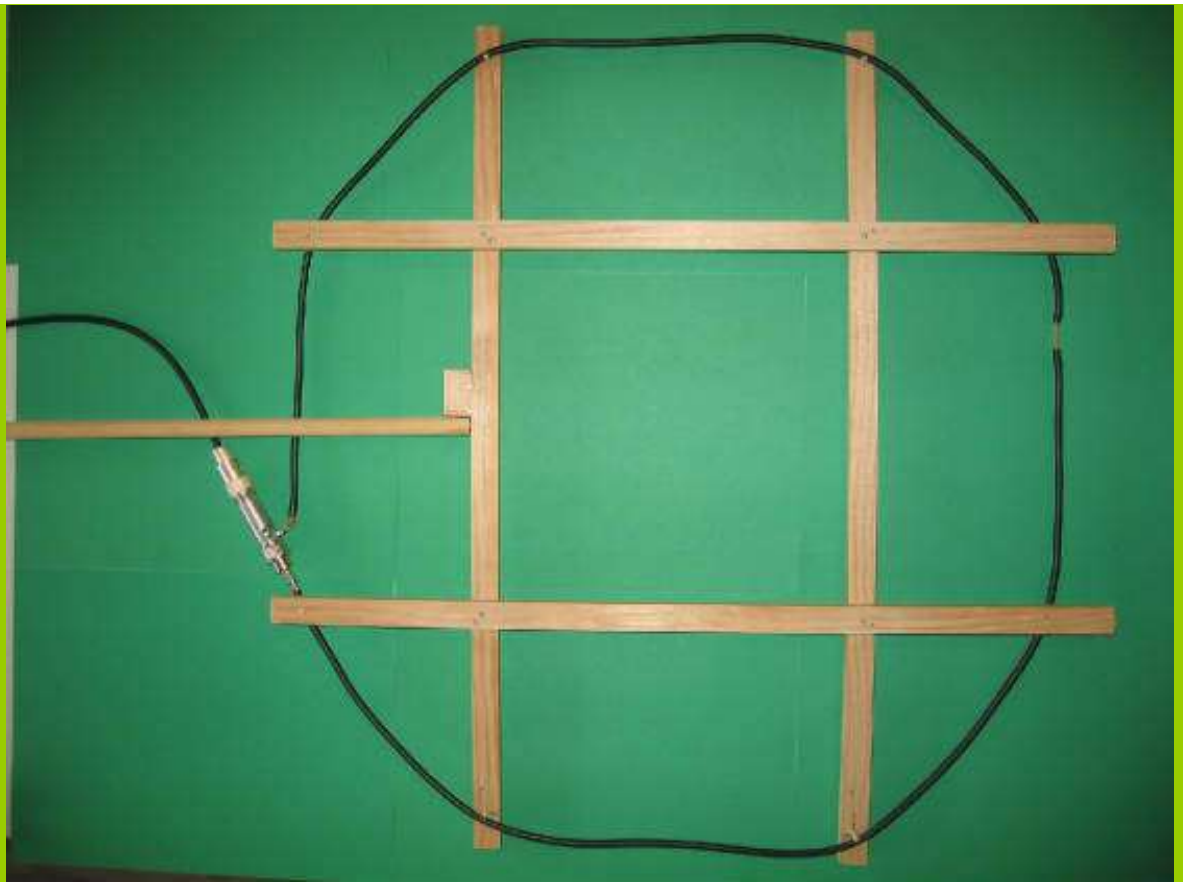

RESULTS

This simple and inexpensive loop works remarkably well for something so cheap and simple. It has given me enhanced receive performance in three areas:

1. Nulling noise sources and interference - Orienting the loop so that the plane of the loop is directly aimed at a noise source (and it works for noise sources either near or far, it doesn't matter) allows you to essentially remove the noise. The nulls are sharp, meaning a slight rotation of the loop will pass through it if you're not careful. Of course, if the noise source is in line with the bearing to the signal you want to receive this is not going to help - but in cases where the bearings are different it is a significant help. I am now able to eliminate some sources of noise that have plagued me for years.
2. Peaking desired signals - Aim the plane of the loop to maximize the desired signal and other signals are reduced in strength (unless they are on the same bearing). This loop receives a bi-directional figure-8 pattern, where the peak is in the plane of the loop and the null is broadside to the loop. This little antenna has excellent directivity - I have enjoyed orienting the loop for peak signal strength on both DX as well as US stations and for the majority of cases I can determine the Great Circle Bearing within 5 degrees of the actual bearing. If you enjoy RDF (Radio Direction Finding) pursuits on HF, this is a neat way to do it. There are instances where signals don't show much directivity - I have especially noticed this on Near Vertical Incidence Skywave signals.
3. Lower noise floor - The loop delivers a lower strength signal than a conventional antenna so you need to compensate for this with your transceiver's preamp (or use an external preamp after the antenna coupler and in to the receiver) to bring the signal back up. By doing this in combination with reducing your RF gain and using your AF gain to bring up the signal for comfortable listening you will have reduced the noise floor in your system and will enjoy quieter receive performance. Of course your S-meter won't read like it normally does, but that's a slight penalty to pay when you can hear signals without so much noise!

I am pleased with the improvement this loop has provided in my receive capability. I am able to copy some weak-signal DX I previously could not copy at all and I can now listen on the lower bands with the 40/80m loop and enjoy improved noise conditions.

Here is the greertech website on this loop design:

<http://www.greertech.com/hfloop/mymagloop.html>

Prototype 40m Loop - works great!



