

AT MICROFICHE
REFERENCE
LIBRARY

A project of Volunteers in Asia

Low Cost Country Home Building

by: Technical Assistance Group, Department of
Architecture, University of Sydney

Published by:

Department of Environment and Planning
175 Liverpool Street
Sydney, NSW
Australia

Available from:

Apac Rural Development Centre
Federal via Lismore
New South Wales 2480
Australia

Reproduction of this microfiche document in any
form is subject to the same restrictions as those
of the original document.

LOW COST COUNTRY HOME BUILDING

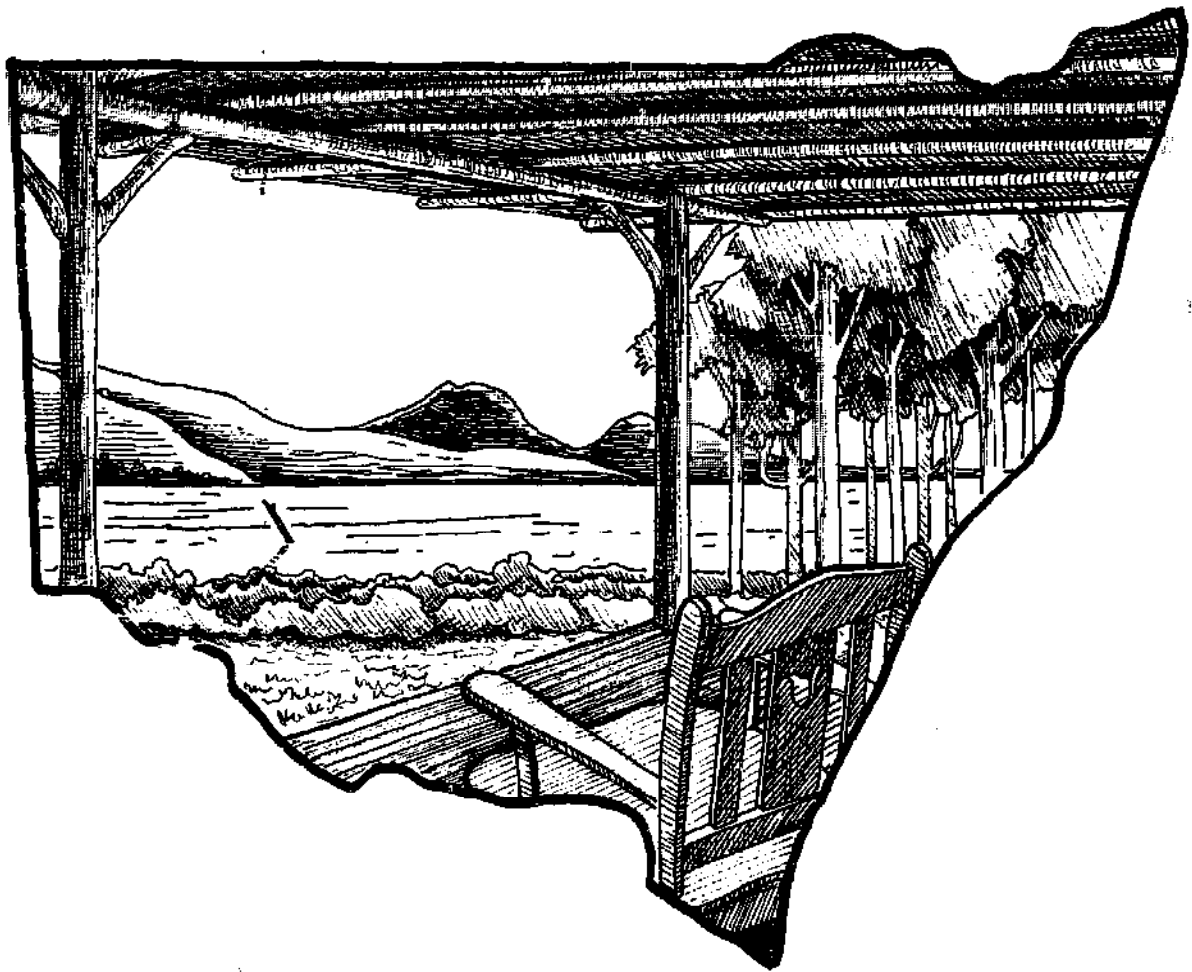

DEPARTMENT OF ENVIRONMENT & PLANNING

LOW COST COUNTRY HOME BUILDING

A handbook on the essentials of low cost construction
for the guidance of rural homebuilders

Prepared by The Technical Assistance Group,
Department of Architecture, University of Sydney

distributor:
APACE RURAL DEV. CENTRE
FEDERAL
via LISMORE
NSW 2480
AUSTRALIA

Department of Environment and Planning
175 Liverpool Street, Sydney.
May 1981
80/60 ISBN 7240 4556 2



FOREWORD

In December 1979 the former New South Wales Planning and Environment Commission organised a seminar to discuss Hamlet Development in New South Wales at which the then Minister for Planning and Environment, Mr Paul Landa, announced that experimental building areas would be set up to test new building forms and materials for residential development and to give a broader understanding of building and health regulations to Councils, their staff, new settlers and all home owner-builders.

This handbook, produced as a result of the Experimental Building Area program, has been published, not as a final document, but for public discussion.

I feel certain that it will help those with limited expertise in home building by providing information which is not otherwise easily available on low cost materials and forms of construction. All the methods of construction and the materials described in the handbook are within the framework of the State's building regulations.

The Department of Environment and Planning would be pleased to receive comments and suggestions until 31 December 1982.

A handwritten signature in cursive script that reads "Eric Bedford". The signature is written in dark ink on a white background.

ERIC BEDFORD
Minister for Planning and Environment

CONTENTS	FOREWORD	3
	ACKNOWLEDGEMENTS	6
	ORGANISATION OF THE HANDBOOK	7
	INTRODUCTION	9
PART ONE	DEFINITIONS	11
	CLASSIFICATIONS	11
	RESPONSIBILITY AND LIABILITY	12
PART TWO	PROCEDURES PRIOR TO CONSTRUCTION	13
	Movable dwelling licences. Development approvals. Building applications. Owner-builder's permits. Insurances. Appeals and objections.	
	PROCEDURES DURING CONSTRUCTION	16
	Inspections. Variations.	
	PROCEDURES AFTER CONSTRUCTION	16
	Occupancy.	
PART THREE	CONCEPTION	17
	Site requirements. Site selection. Landscaping for energy conservation. Room sizes, heights, light and ventilation. Workmanship. Choice and quality of materials. Thermal insulation.	
	STRUCTURE	28
	Factors influencing choice of structure. Structural principles. Unusual and innovative structures. Connection of a building to the earth. Massive construction. Timber construction.	
	ENVIRONMENT	49
	Enclosure and weather-proofing. Floors, walls, roofs, openings.	
	SERVICES	56
	Water supply. Hot water supply. Gas plumbing. Drainage and sanitary works. Electrical work. Fireplaces and stoves.	
APPENDIXES	1. Policy on multiple occupancy.	67
	2. Penalties.	
	3. Guide letters to Council.	
	4. Plant material.	
	5. Selection of timber species.	
	6. Chemical preservation of timber.	
	7. Knee braced frames: Round timber poles.	
	8. Proposed minimum house specification and plans.	
	9. Australian Standards.	
	10. Experimental Building Station publications.	
	11. Submissions received.	
	REFERENCES	115
	GLOSSARY OF BUILDING TERMS	116

ACKNOWLEDGEMENTS

This handbook was prepared under the guidance of the Liaison Committee for the Experimental Building Area program nominated by the Minister for Planning and Environment. The information contained herein does not necessarily reflect the views of the organisations with whom they are identified.

LIAISON COMMITTEE MEMBERS

Dr John Roseth
Head, Research and Services Division, Department of Environment and Planning

Mr Fergus Neilson
Central Policy Division, Department of Environment and Planning

Alderman W. G. Blair
Mayor, Council for the City of Lismore

Mr Warwick Sherring
Senior Building Inspector, Council for the City of Lismore

Mr Ron Short
Shire Health Surveyor, Principal Building Inspector and Town Planner, Bellingen Shire Council

Mr John Lyons
Health and Building Surveyor, Blacktown Council

Mr Phil Ansoul
Deputy Health and Building Surveyor, Parramatta Council

Mr Paul Taylor
Secretary, Australian Institute of Health Surveyors

Mr John Armstrong
Deputy Chief Building Inspector, Builders Licensing Board

Mr John Frawley
Senior Legal Officer, Builders Licensing Board

Mr Ted Charker
Chief Health Inspector, Health Commission of N.S.W.

Mr Barry Sagar
Principal Building Surveyor, Department of Local Government

Mr E. J. Daly
Building Advisory Officer, Department of Local Government

Mr Frank Fotea
Research Officer, Local Government and Shires Association

Ms Julie Walton
Project Officer, Local Government and Shires Association

This handbook was prepared by the Technical Assistance Group from the School of Architecture, University of Sydney, and nominated Research and Technical Assistants.

TECHNICAL ASSISTANCE GROUP MEMBERS

Richard Aynsley BArch (Hons), MS (Arch Eng), PhD
Patrick Healy, BE, DIC, MSc, MBA, MIE Aust.
Graham Holland, BArch, ARAIA, ARIBA
Colin James, ASTC (Arch), MArch, ARAIA, DipT&CP, MRAPI
Warren Julian, BSc, BE, MSc(Arch), DipBldgSc, MIES(Aust)
Brian Woodward

RESEARCH AND TECHNICAL ASSISTANTS

Toni Appleton, co-editor
Edwin Buivids, BArch(Hons)
Jane Dillon, BSc(Arch), BArch(Hons)
Denis Fulford, BE(Hons)
Peter Hamilton, BArch
Nicholas Hollo, BSc(Arch), BArch(Hons)
Stephen Lesiuk, BArch(Hons)
Helen Lochhead, BSc(Arch)Hons
Daniel McNamara, BSc(Arch), BArch, co-editor
Gary Mitchell, BSc(Arch), BArch
Diane Moon, typist
Stephen Stokes, BSc(Arch), BArch, co-editor
John Watson, BA, DipEd
Ian Gaillard, homebuilder
David Gittus, homebuilder

ORGANISATION OF THIS HANDBOOK

This book is divided into four main parts, each outlining the area of influence of the building regulations, or the ways in which that influence is exercised in relation to both the local council and the intending homebuilder.

Part One deals with the preliminary assumptions and definitions from Ordinance 70 (the regulations concerning building in the N.S.W. Local Government Act, 1919), confined to the essentials of domestic construction. It contains information on the classification of different building types, and gives a brief outline of the legal relationship between the local Council and the home builder, as regards their mutual responsibility and liability in the province of domestic construction.

Part Two outlines the procedures used by local authorities to administer the Ordinance to homebuilders. This section has been further subdivided into:

- 1) Procedures prior to construction. This explains the functions of movable dwelling, development and building applications, owner builders' permits, insurances and the means of redress via appeals and objections.
- 2) Procedures during construction. Inspections and variations to ensure the smooth execution of the job.
- 3) Procedures after construction, related to occupancy.

Part Three describes how the Ordinance influences design and construction, and is intended as a guide to those wishing to carry out this work personally. In general, descriptions of building techniques have been avoided, as these have been adequately covered in many other publications. However, where original material has been provided, and is not readily available elsewhere (for example siting and landscaping for energy conservation, and quantitative guides to earth and round timber construction) these have been included.

The principle underlying this section is that design is an input into every stage of a project, which becomes more and more concrete as steps are taken towards its realisation, from the initial considerations in the mind through the stages of drawings and model making, to, finally, the full-scale construction of the building. The construction details are intimately tied to the overall design, and hence any particular aspect of the building should be considered in its context as part of a larger system, itself composed of smaller parts.

Thus the following subsections have been loosely arranged to correspond with the steps normally taken in the realisation of a building project. However, it should not be taken to imply that, for example, building services such as water supply or drainage are an afterthought that can be patched in to an almost completed building. It may be that it is possible for construction to proceed out of sequence, but bad planning invariably results in wasted time, wasted materials, and decline in the overall job quality — factors which are as important to low cost owner-built work as to the most sophisticated construction. Thus a grasp of each subsection will assist the intending builder to make design decisions based on some knowledge, and in accordance with the Ordinance.

The first section is concerned with the initial considerations, such as siting, room planning, materials, and other resources.

Then follows a section on the structure of the building, those parts which go to make up the loadbearing skeleton, and the structural choices open to the intending builder.

The third section concerns those principles of enclosure and weatherproofing, the making of surfaces and openings so that the spaces of the building are suited to the lifestyle of the inhabitants.

The fourth section outlines those common services which a homebuilder may wish to provide in the dwelling — hot and cold water supply, gas supply, drainage and waste disposal, electrical work and heating devices such as stoves and fireplaces.

Part Four of the handbook, the Appendixes, provides detailed information on a number of matters treated more generally in the text.

This handbook is intended to be read in conjunction with the works listed in the References, which will help to inform the homebuilder of the background to many of the principles outlined.

Local building practice should further guide the homebuilder, as the intention of this handbook has not been to cover all materials and practices in use, but rather to outline the principles of building low cost, sound and environmentally responsible housing which reflects the values and aspirations of the inhabitants.

INTRODUCTION

The need for this handbook arose from the housing aspirations of new settlers in rural N.S.W., particularly within the North Coast region. An increased awareness of environmental values together with a desire to lead a simplified lifestyle has led to a re-evaluation of rural building practice. To meet these needs, many new settlers are building their own homes using local materials and both simple and traditional building methods. These techniques have been particularly useful in providing emergency and very low-cost accommodation.

Under these circumstances it has been found necessary to provide improved information for aspiring home builders, particularly with regard to siting and building healthy and safe housing within the State building regulations. At the same time, information has been provided to guide Council building officers in their interpretation of the building ordinance to allow them to provide a more effective service to homebuilders.

This has not been without difficulty. Homebuilders organisations have argued for less regulation and more personal responsibility, whereas Local Government representatives have been pressing for more stringent standards interpretations to reduce their liability. It is hoped that this document will show how homebuilders could realise most of their aspirations within the scope of the regulations. At the same time, it may promote a better understanding between homebuilders and their Councils, where both may co-operate to provide a healthy and safe environment for living.

A work of this magnitude has only been possible through the co-operative effort of many people. The assistance provided by the Department of Environment and Planning (formerly Planning and Environment Commission) has been central to every aspect of the work, in particular the setting up and work of the Liaison Committee for the Experimental Building Area programme, who supervised the preparation of the handbook in all its stages. This committee was widely representative of all Government bodies involved in health and building and was invaluable for the guidance given and assistance with interpretation of the various regulations.

A complementary role was played by the Homebuilders Association from the Lismore region who effectively represent new settlers. Their contribution as a group and as various contributors has provided the inspiration and stimulus to engage in such a task. Their submissions and counsel has ensured that the work will be of practical use to inexperienced people building their own home.

The handbook was widely circulated in Government and Technical circles in a draft form prior to final editing. The submissions received are identified elsewhere in the handbook and provided a very useful check as well as new material for incorporation.

The Technical Assistance Group from the Department of Architecture, University of Sydney, take responsibility for work in the handbook, and acknowledge the major role of numerous research assistants. The T.A.G. took advantage of many skilful and experienced homebuilders, architects and engineers from the North Coast region who provided a practical balance with advanced research workers and sophisticated resources from the University of Sydney.

The Group is confident that within the terms of

reference working within the scope of the existing building regulations that this handbook will provide significant guidelines for Low Cost Country Home Building in New South Wales.

Colin James
Sydney, 1981

PART ONE

Part One contains definitions used in this handbook, most of which are selected from Ordinance 70 for their relevance to domestic construction. A wider list of terms appropriate to design and construction is contained in the Glossary, which is by no means exhaustive, but should help to clarify most sections of this handbook for the non-technical reader.

Part One also contains information on the classification of building types likely to be used in rural areas for domestic construction.

The final section of Part One is an opinion on the responsibility and liability of both Councils and homebuilders prepared by an eminent barrister experienced in N.S.W. Local Government law.

DEFINITIONS (see also the Glossary of Building Terms)

ACT means the Local Government Act, 1919.

AUSTRALIAN STANDARD means a publication, including an Australian Interim Standard, published by the Standards Association of Australia.

BUILDERS LICENSING ACT means the Builders Licensing Act, 1971, as amended.

COURT means the Land and Environment Court.

DWELLING HOUSE means a building intended for use as a dwelling by members of a household.

EXPANDED HOUSE means a group or cluster of buildings which together function as a dwelling house or Class I building. [An expanded house is *NOT* a multiple occupancy, which is a group of dwelling houses, expanded or otherwise, on one allotment of land.]

FOOTING means that part of the structure in immediate contact with the foundation, transferring the loads from the building to the foundation.

FOUNDATION means the ground which supports the building.

HABITABLE ROOM means a room (other than a bathroom, laundry, water closet, or the like) that is designed, constructed, or adapted for the activities normally associated with domestic living, and for this purpose — (a) includes a bedroom, living room, lounge room, music room, television room, kitchen, dining room, sewing room, study, playroom, sunroom, and the like; and (b) excludes in addition to bathrooms, laundries, water closets, and the like, such rooms or spaces as food storage pantries, walk-in wardrobes, corridors, hallways, lobbies, photographic darkrooms, clothes-drying rooms and other spaces of a specialised nature occupied neither frequently nor for extended periods.

KITCHEN means a habitable room, alcove or other space provided for the purpose of preparing and cooking of food for the exclusive use of domestic living.

LOADBEARING, applied to a wall, a part of a wall, a shaft, or any similar member, means intended to support a vertical load additional to its own weight.

MASONRY means stone, brick, concrete block, or other similar building unit, or a combination thereof, assembled together unit by unit to form a wall, pier, chimney, or other part of a building.

MEZZANINE means a space within a room which is not fully enclosed nor encloses the space below it and is situated between — "(a) an intermediate floor constructed within a room, and (b) the floor level, ceiling or roof above, as the case may be; and in which the intermediate floor does not extend across the full area of the room." (ORDINANCE 70) (This definition is under review by the Local Government Department)

MOVABLE DWELLING means any tent, van, or other conveyance whether on wheels or not, and any shed or similar structure or conveyance which is used either regularly or intermittently for human habitation.

MULTIPLE OCCUPANCY, for the purposes of this handbook, means a group or groups of Class I and Class X buildings on one allotment of land, and does not include any Class II or Class III buildings.

ORDINANCE means Ordinance 70, 1972, under the Local Government Act, 1919.

OWNER, in relation to land, includes every person who, jointly or severally, whether at law or in equity — (a) is entitled to an estate of freehold in possession in the land; (b) where the land is Crown lands under a prescribed tenure, is entitled to any prescribed estate or interest in the land as prescribed by the Building Licensing Regulations; (c) where the land is not Crown lands, is entitled to any prescribed estate or interest in the land as prescribed by the Building Licensing Regulations.

OWNER-BUILDER, in relation to any building work, means a person who carries out that building work pursuant to an owner-builder's permit, issued under the Builders Licensing Act, 1979.

PUBLIC HEALTH ACT means the Public Health Act, 1902.

STRUCTURAL MEMBER means a part of the structure of a building, and includes a footing, column, pier, wall, parapet, partition wall, shaft, floor, roof, ceiling, stair, landing, ramp, or balcony, and any supporting part incorporated therewith.

CLASSIFICATIONS

It is important to establish clearly the classification of any building, as some provisions of the Ordinance apply to certain classes of buildings and not to others.

The following classifications of buildings are found in the Ordinance:

(a) Class I: Single dwelling-houses.

(b) Class II: Buildings containing two or more flats.

(c) Class III: Residential buildings, being common places of abode for a number of unrelated persons, including —

- (i) boarding houses, guest houses, hostels, and lodging houses;
- (ii) the residential portion of hotels and motels;
- (iii) the residential portions of schools;
- (iv) the residential portions of institutional buildings accommodating members of the staff of the institution; and
- (v) flats not included in paragraph (b).

(d) Class X: Outbuildings. These may include greenhouses, conservatory, summer-house, boat-house, fuel shed, tool-house, aviary, milking-bail, hay shed, stable, fowl-house, pigsty, barn or the like.

RESPONSIBILITY AND LIABILITY

Section 311 of the Local Government Act provides that a building shall not be erected or altered unless the approval of the local Council is obtained *beforehand*. This is the responsibility of the homebuilder. Part Two of the handbook sets out the relevant procedures.

Apart from statutory responsibilities, an owner of a building has a general common law responsibility in relation to building work. The work must be undertaken carefully, with due regard to the safety of the future occupants of the building and the interests of owners and occupiers of other properties in the neighbourhood. This does not preclude low cost building and the use of second-hand materials. It does mean that care should be taken to ensure that appropriate, sound materials are chosen and that proper building techniques are used. The advice set out in Part Three should materially assist homebuilders in meeting those requirements. However, no book can foresee all problems. If the homebuilder is in doubt, in relation to any matter which might involve the safety of persons or property, he should obtain advice on the problem from a suitably experienced person.

The Local Government Act places upon Councils the responsibility of ensuring that buildings erected within their areas are erected in accordance with ordinance requirements. Under some circumstances, Councils (and their officers) may be held liable to pay damages to persons who suffer loss or damage as a result of a neglect of that duty. The responsibility is not an absolute one; the Council must be shown to have failed to take reasonable care in some material respect e.g. consideration of the building plans, inspection of the site or of foundations. Council's responsibility is well understood. It applies to all buildings. In principle there is no reason why new or additional problems should arise out of the increasing popularity of low cost country home building. Perhaps, however, there have been practical difficulties; building inspectors, inexperienced in this type of construction, may have felt uncertain as to appropriately acceptable standards. This handbook attempts to specify those standards. Generally speaking, adherence to the requirements of the handbook should obviate any legal difficulties for both builder and Council.

Murray Wilcox Q.C.

PART TWO

Part Two outlines the procedures by which the Local Government Act and Ordinance 70 interact with the homebuilder. These procedures take the form of applications, permits and approvals which must be sought from Local Councils or other authorities, and the avenues of appeal by homebuilders against the decisions of those bodies.

Part Two has been subdivided according to the place that these procedures occupy in relation to the construction process, namely:

Procedures prior to construction:

- *Movable Dwelling licenses* for shelter prior to and during construction.
- *Development Approval* to ensure that the proposed land use is in accordance with local zoning and planning regulations.
- *Building Application* showing details of intended building/s.
- *Owner-builder's permits*
- *Insurances*
- *Appeals* against the decisions of Councils or other bodies on any of these matters.

Procedures during construction:

- *Inspections* made by Council officers at stages during building.
- *Variation* procedures for altering or amending Building Applications to accord with changes desired by the homebuilder.

Procedures after construction:

- *Occupancy* approval at an appropriate later stage in construction.

PROCEDURES PRIOR TO CONSTRUCTION

Movable dwellings

Persons wishing to camp on land, either temporarily or while building a permanent dwelling, should apply to the Council for a Movable Dwelling licence. Where such an application has been made to the Council "... the council shall be deemed to have granted it unconditionally, unless, within four weeks from the receipt thereof, the council or its authorized servant gives notice to the applicant stating that his application is refused, or stating the conditions subject to which the licence is granted" (Section 288A(6) of the Act).

Some Councils have application forms for Movable Dwelling licences. If not, homebuilders may use the form of letter included here as a guide for an application for a licence. The Council may, within the period stated above, impose conditions such as a fee and/or a period for the licence, after which extensions as necessary should be sought.

Under Section 288A(7) of the Act, a Movable Dwelling licence is not required for a movable dwelling which:

- (a) is kept by its owner on land occupied by him in connection with his dwelling house and is used for habitation only by him or by members of his household; or
- (b) is kept by its owner on pastoral or agricultural land

occupied by him and is used for habitation only in certain seasons and only by persons employed in pastoral or farming operations on that land.

In all other cases a licence is necessary. See Appendix 3 for guide letter to Council.

Development Applications

The following situations may arise where it is necessary to obtain Council's consent to the proposed use of land (Development Approval):

- (a) Where it is proposed to build a single dwelling on an allotment which is less than the required area for its zoning;
- (b) where it is proposed to build in an area of high landscape significance;
- (c) where it is proposed to build more than one dwelling on an allotment that is, a "multiple occupancy";
- (d) where it is proposed to build extra dwellings on an allotment where a dwelling already exists, e.g. a farm-worker's cottage.

Homebuilders should consult the Council's planning officer as to whether an application for Council's consent to the proposed use of land (a Development Application) needs to be submitted. It is strongly advised that you do this *before* completing the purchase of an allotment, and that you or the vendor obtain the appropriate consent before the settlement if possible. If necessary, make the contract conditional upon consent being obtained.

In some areas, planning instruments are currently being amended to permit multiple occupancy with the consent of Council. If this is the case in the area in which it is proposed to build, homebuilders may wish to seek an understanding from the Council that it will permit the total proposal once the necessary amendments have been made, so that work may proceed on as much of the development as is currently permissible (e.g. construction of a single dwelling and farm buildings).

If there are significant delays in introducing amendments, the Council may be willing after discussion to arrange for a special zoning for that particular allotment.

Councils are expected to base their policies for multiple occupancy on the policy of the Department of Environment and Planning as set out in Circulars 44 (see Appendix 1).

In considering the case of single dwellings, the following basic information is required:

- 1) A description of the land giving lot, portion or deposited plan numbers;

- 2) the dimensions and area of the allotment;
- 3) the signature of the landowner authorising the making of the application;
- 4) a description of the present use of the land and the use of any buildings on it;
- 5) a description of the proposed use of the land and proposed buildings.

In addition, the homebuilder should provide adequate information on the following points which may be considered by the Council when making a decision concerning a Multiple Occupancy Application:

- 1) adequacy of access;
- 2) adequacy of water supply and drainage;
- 3) adequacy of waste disposal facilities;
- 4) relationship to neighbouring land uses;
- 5) relationship to existing facilities and services;
- 6) bushfire risk,
- 7) potential erosion hazard;
- 8) site vegetation coverage;
- 9) agricultural suitability;
- 10) siting of proposed buildings.

Homebuilders proposing multiple occupancy developments should consult the Council's planning officer to ascertain exactly what will be required.

A fee will be charged by the Council for a Development Application.

Building Applications

It is necessary to obtain Council's consent to the details of any proposed buildings (Building Approval) and the first stage in this process is to submit a Building Application.

FORMS

Forms for Building Applications are available from Council. A typical form is shown opposite.

Councils have 40 days in which to make a decision in relation to a Building Application.

DRAWINGS

Drawings of the proposed building should accompany the Building Application form. Two or three copies are required, so drawings should either be done on tracing paper for dyeline printing or on opaque or tracing papers for photocopying.

Part 8 of the Ordinance requires that the drawings include:

- 1) Plans of floors of the building showing all linear dimensions and the positions of any sink, tub, bath, etc. Mezzanines should not be shown as separate floors unless they are designed to have regulation ceilings. Scale should be 1:50 or 1:100.
- 2) Elevations of at least two sides of the building showing the levels of the ground around the building and any relevant vertical dimensions, the positions and size of any openings and the type of wall cladding or finish. Scale should be 1:50 or 1:100.
- 3) A location plan or block plan showing the position of the building, access roads, boundaries, drains from waste water fittings to absorption trenches and the

position of the cesspit or whichever system is used. Scale can be that used on surveys for titles, but in most cases this would have to be enlarged to show the information adequately.

- 4) In the case of unusual and innovative buildings, a drawing of a section through the building, showing details which cannot be shown on plans and elevations. Scale should be 1:50, 1:20, 1:10 or 1:100.

SPECIFICATIONS

Some Councils have a standard form of specification which the applicant should complete. Parts of it will be irrelevant to most applications, in which case these clauses should be deleted. Where the local Council does not have a standard specification, the relevant information can be shown by the inclusion in the Building Application of a drawing of a section through the building drawn at 1:50, 1:20 or 1:10 scale with more detailed descriptions of the construction and materials to be used than can be shown on the plans and elevations. The Ordinance also requires secondhand materials or components to be specified. Specification notes for the Minimum House Plans have been included in Appendix 8.

FEES

A standard fee should be lodged with the local Council at the time the applicant submits a Building Application for approval. This fee is calculated as a percentage of the estimated cost of the building where there is no contract price as in the case of owner-builders. The likely cost of the building project should be discussed with the building inspector. Any receipts for materials already purchased should be produced at this time to support the homebuilder's estimate of the cost.

One-half of this fee is refunded if the application is not approved and the owner applies for the money back. If the applicant withdraws an application before the drawings have been checked by the Council, while waiting on a structural engineer's certificate, three-quarters of the fee is returned.

A further \$75 may be payable to the Council towards meeting the costs of the services of a structural engineer in the case of unusual forms of construction.

Fees may not be applied to certain out-buildings or for minor alterations to existing buildings (Ord.70 Clause 8.4(C)).

Some Councils charge extra set fees for all the forms required to be submitted.

Owner-builder's Permits

An Owner-builder's permit from the Builders Licensing Board is not required if:

- 1) the building costs less than \$1000 (at the time of this publication);
- 2) the work is carried out under the Rural Workers' Accommodation Act, 1969.

If a permit is necessary, the Council will not release an approved Building Application until the Owner-builder's permit has been sighted.

Application forms for permits are available from the Council, State Government offices, or the Builders Licensing Board which has offices at Sydney, Coffs

TYPICAL BUILDING APPLICATION

Local Government Act, Ordinance 70

N.B.: Failure to complete this form in its entirety may result in the application being returned for completion.

1. — **PLANS AND SPECIFICATIONS:** Plans and Specifications shall be submitted in at least duplicate. A General Plan, drawn to a min. scale of 1:100, shall show all floor plans, elevations, sections, related ground levels, height, design, construction, provision of fire safety, figured dimensions of all rooms and a drainage diagram showing the proposed treatment of household wastes and roof water. A Site Plan, drawn to a min. scale of 1:200, shall show the relation of the proposed building and any existing buildings to all boundaries of the allotment and the street to which it fronts and/or is bounded. Indicate on block plan the position of any allotment drainage easement, natural water course, existing buildings and drainage associated therewith. Where alterations or rebuilding is proposed two copies of plans shall be coloured to distinguish the alterations or rebuilding. All plans must be drawn on opaque paper. Plans drawn in pencil will not be accepted.

2. — The Shire Clerk.

Sir, —

Application is hereby made to Council for the approval of attached Plans and Specifications for the erection of a building.

3. — PARTICULARS OF LAND:

LOT No.
 SEC. No.
 D.P. No.
 STREET
 LOCALITY
 HOUSE NAME/No.
 FRONTAGE
 DEPTH
 Between cross streets
 and

4. — PARTICULARS OF BUILDING:

CLASS OF BUILDING
 (State Class I, II, etc., or combination of Classes — See Cl. 6.1.)
 ESTIMATED COST
 OF BUILDING / S
 DESCRIPTION OF BUILDING
 (e.g., Dwelling, res. flats, shop and dwelling combined, garage, additions, pools, etc.)

EXTERNAL MATERIALS

Walls:
 Fences to Public Place: Height
 Roof:
 Materials
 (Note: Footing levels of fences are to relate to finished levels of footway.)
 Has Development Application been submitted? YES/NO. Land Use Consent No.
 Has any previous correspondence been submitted to Council: YES/NO. Reference No.

5. — FULL NAME OF OWNER (BLOCK LETTERS) FULL NAME OF BUILDER (BLOCK LETTERS)
 (or Company) (or Company)

(First Names) (Surname) (First Names) (Surname)

ADDRESS ADDRESS

'PHONE No. 'PHONE No.

6. — I undertake to comply with the provisions of the Local Government Act 1919 & Ordinances, especially Ordinances Nos. 70, 30, 39 and 44 and all amendments thereto, and the Rules and Conditions of the Council of the Shire of

State whether applicant is Owner/Builder/
 Architect/Structural Engineer or Managing
 Director/Manager/secretary. Where a company is ap-
 plicant company stamp or seal to be affixed. Signature of Applicant.....
 Date.....

Inspectors may be interviewed between 8.30 a.m. and 10 a.m. daily, or by appointment.

LOCATION SKETCH
 (Show nearest cross street and compass north.)

Harbour, Orange, Newcastle, Wollongong and
 Armidale.

The Builders Licensing Board does not require drawings to accompany the application for a permit, only a description of the type of building to be constructed — for example, "A single dwelling house constructed with round hardwood poles, clad with treated hardwood flitches and with a recycled galvanised iron roof, including outbuildings."

The Board charges a \$20 fee for a permit.

Each single dwelling house (Class 1 building) on a communally owned rural property is required to have a separate permit. No separate permit is required for outbuildings and joint owners may apply for a single permit for any communally occupied buildings.

The Board advises that any owner-builder intending to use trade contractors for work worth more than \$200 should make sure that they are licensed.

Insurances

Homebuilders are advised to ensure that they are adequately covered for Third Party/Public Risk by an appropriate insurance policy, which would cover visitors and helpers on the site against accident.

Worker's compensation insurance would be necessary if the owner employs any contract or casual labour. Licensed trade contractors are covered by their own insurance.

Homebuilders may wish to insure themselves against any risks normally incurred during construction work with a personal accident policy.



Appeals and Objections

Appeals and objections are the homebuilder's means of redressing grievances against the law or its interpretation.

An appeal may be directed against a Council's interpretation of the Local Government Act and Ordinances, or its use of its discretionary powers in relation to a particular case. An objection is directed against a particular provision of the Act or Ordinances, which only the Courts have power to modify.

Appeals against decisions are far more common, and less complex, than objections to the Act.

A right to appeal arises when an applicant is aggrieved by any decision, neglect or delay by a Council in relation to Development Applications, Building Applications, Movable Dwelling licences, or Occupation before completion.

Before a homebuilder takes the step of appealing to the Courts, it may be possible to ask the Council, through its Town or Shire Clerk, to reconsider its decision in the light of extra information and discussion, or to reach some form of compromise.

Appeals against decisions or conditions relating to movable dwellings must be lodged with the District Court within 90 days. Appeals relating to other matters as above are lodged with the Land and Environment Court within 12 months; a fee of \$25 applies. Forms and information about procedure are available from the Court and at local Courts of Petty Sessions.

Councils and responsible authorities are obliged to advise applicants served with notices or directions of the reasons for decisions made in relation to applications, and of the rights of applicants to appeal to the Courts.

Under normal circumstances a preliminary conference will be arranged with an assessor. If no agreement is reached the matter will proceed to a hearing. The hearing should be conducted with little formality and technicality and the owner-builder may represent his/her case without legal assistance.

If contemplating an appeal, owner-builders should witness other cases to become familiar with the procedures and to decide whether legal assistance should be obtained. Legal aid may be available in cases of genuine hardship.



PROCEDURES DURING CONSTRUCTION

Inspections

When the applicant receives approval for a Building Application the local council will indicate what inspections it may wish to make. The applicant must give 48 hours' notice in writing that the work is ready to be inspected, after which time the work may proceed. Some Councils provide cards which should be submitted at the appropriate time.

The building must be "substantially commenced" within 12 months after approval of a Building Application or the approval lapses and an extension has to be sought or another application made. There is no time limit for completion of a building project.

However, if the owner applies for permission to occupy the building before completion, the Council may impose a time limit for completion of the work.

Variations

The positions of proposed openings, doors, windows, fixed glazing, etc. shown on the elevations must be adhered to, but approval for alterations should be forthcoming provided they remain adequate in area according to the Ordinance (Part 50).

Alterations and/or additions to the drawings and specification may take place during construction. Councils require notification of major changes either in writing or as an amended drawing, whichever is appropriate. Variations should be discussed with the Inspector on site or at the Council Offices before they are carried out.

PROCEDURES AFTER CONSTRUCTION

Occupancy

An owner must make an application in writing to the Council for approval to occupy a building which has not yet been completed (Ordinance 70 Part 3.4(1)).

The homebuilder or owner should use the form of letter included in Appendix 2 as a guide for an application to occupy a building before completion. The Council may permit occupation subject to any conditions appropriate to the particular case, after discussion with the owner. If this permission is revoked by the Council, it must give at least six months' notice to the occupier of its intention to do so.

PART THREE

The third part of this handbook describes how the technical provisions of the Ordinance influence design and construction of dwellings, and is intended as a guide to those wishing to carry out this work personally.

It has been broken up into four main areas, each corresponding loosely to the stage at which it may be considered during the design process. The scope of each section is set out below.

Conception

— The way the site and landscape should influence and be influenced by the building design. Information is also included on basic thermal design concepts.

— Minimum requirements of the Ordinance concerning room sizes, ceiling heights, light and ventilation, workmanship and materials, which should be considered at the planning stage.

Structure

- Factors affecting choice of a structural system.
- The principles of designing stable structural systems.
- Provisions for unusual and innovative structures.
- The connection of the building to the earth.
- Masonry (principally earth) construction.
- Timber (principally round bush pole) construction.

Environment

- Principles of weatherproofing and enclosure.
- Flooring, cladding, roofing, openings.

Services

- Principles of cold and hot water supply, gas supply.
- Drainage and sanitary works.
- Electrical work.
- The provision of fireplaces and stoves.

CONCEPTION

Site Requirements

The site generates many problems and opportunities for the home builder, influencing the planning, structure, choice of materials and ultimate enjoyment of the dwelling. Hence careful consideration of site limitations and potential (most easily done on the site itself) brings its own benefit.

Following are some important site considerations.

CLIMATE AND MICROCLIMATE

New South Wales has vast variations in climatic regions ranging from hot humid zones, through to temperate areas and to predominantly cold regions. The design and construction of buildings in different areas should respond to these variations. Failure to do so may produce environments where habitation is made difficult, if not unpleasant.

Regional climatic design, however, goes only part of the way to producing desirable building forms. The local climate, or micro-climate, of an area may be of more fundamental importance to the design and therefore an understanding of the specific building site is necessary. Unlike regional climates, the micro-climate of a site can be manipulated, either by buildings

and structures or by the judicious siting and selection of vegetation.

LANDFORM

Local topography is an important consideration for the intending homebuilder in that it will determine much of the local micro-climate, the landscape and general gardening potential, and the ease with which a building can be constructed.

The slope of the land is also a good indicator of the amount of rainfall runoff that may occur and will determine the extent of clearing that could be carried out without causing erosion problems.

ORIENTATION

Again, the orientation of the slope is fundamental to both building and landscape considerations. Generally north and north-eastern orientations are most desirable, being less susceptible to frost and overheating.

Southern and westerly slopes should generally be avoided as these orientations are most likely to have extreme micro-climatic conditions, that is colder in winter and hotter in summer respectively.

EXPOSURE TO WINDS

Winds will vary from region to region. More significantly, however, local landforms and topography will vary the regional wind patterns. When a site is being considered, its exposure to winds from different directions should be assessed. It should be noted that not all winds are undesirable: rather, some summer breezes may be most welcome. In assessing a site, consideration should also be given to the future establishment of wind breaks and other structures which may be used to deflect or redirect winds around the building site.

VEGETATION

All vegetation, both existing and proposed, should be considered at the same time as the building is planned. The value of vegetation should be seen in terms of:

- 1) site micro-climate modification (shade and shelter);
- 2) soil erosion control;
- 3) bushfire control;
- 4) renewable building materials;
- 5) food crops;
- 6) the natural ecology of the site.

IMPACT ON SURROUNDINGS

The impact of a development on a site can take two forms: visual and ecological.

Visual. Homebuilders should carefully consider the

INFLUENCE OF SLOPE ON SITE SELECTION

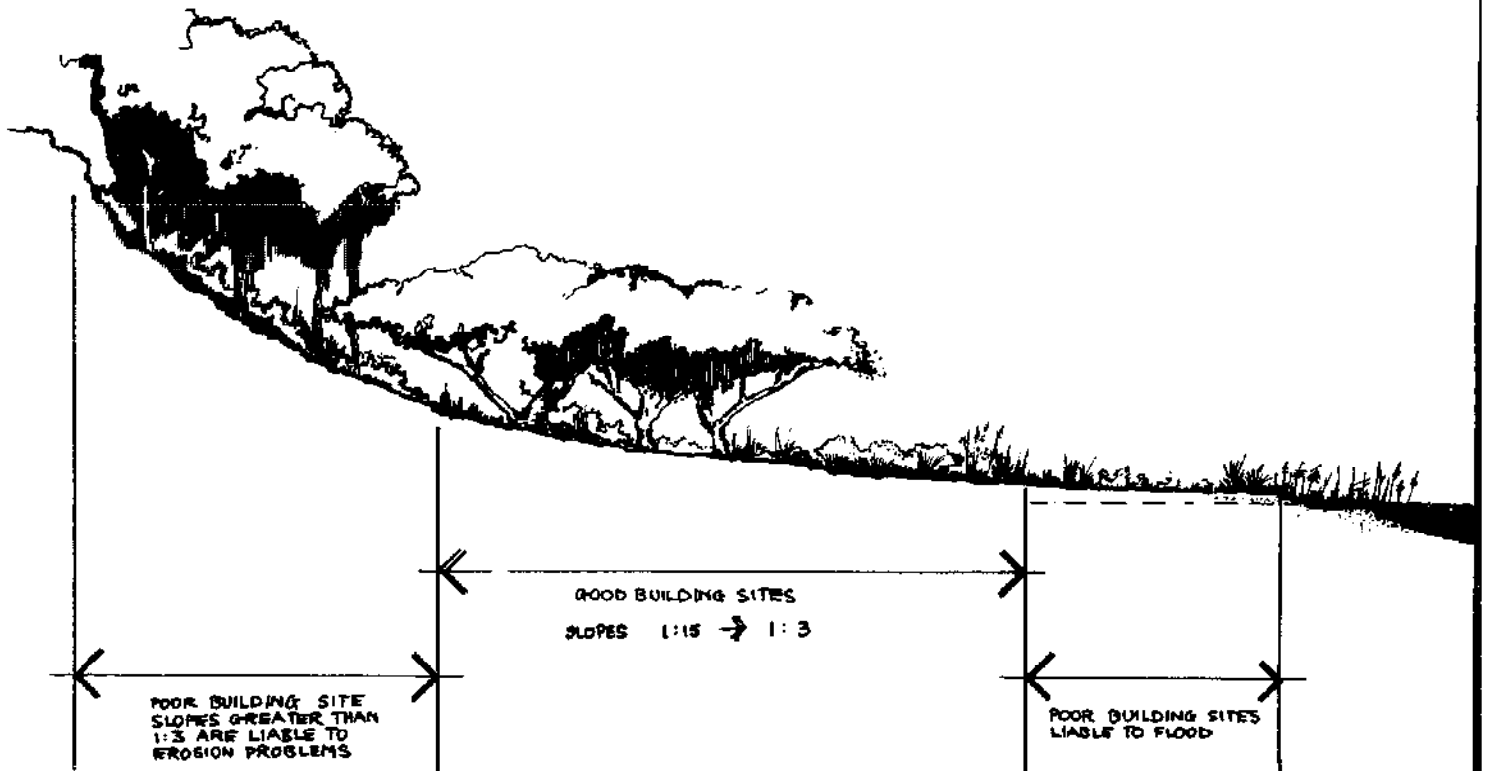

Generally buildings should be sited in areas where clearing will not cause excessive erosion, or in areas where they are not subject to flooding.

scale, size, colour and siting of any building in respect of its surroundings.

Ecological. Sites are frequently chosen for their visual appeal. However, sites which display the greatest diversity of animal and plant life are potentially the most vulnerable to building development. The simple processes of building and living may be enough to upset, if not destroy, the ecology of a site, remembering that:

- some trees may have to be cleared, thereby destroying the upper protective canopy;
- drainage and waste may upset the local water conditions and pollute runoff;
- increased traffic (even pedestrian) may damage the ground cover sufficiently to cause erosion;
- domestic gardens produce seeds which can be carried by winds or birds.

As a rule of thumb, if a site appears “beautiful” because of its diversity, *build elsewhere*. With a little hard work, the homebuilder can develop a less vulnerable site and make it beautiful. Remember also that a site chosen for its beauty initially may degenerate quickly once the building is up.

DRAINAGE

Drainage generally influences the supply and disposal of water (see section on Drainage and Plumbing).

OTHER CONSIDERATIONS

Electricity and access easements, wildlife, sacred sites, privacy and community, noise, future zonings and so on should be considered.

Site Selection

Selection of a site should be made with due regard to local topography, the orientation and angle of slope, existing vegetation, and protected or sheltered areas, as opposed to exposed areas.

LOCAL TOPOGRAPHY

Ideally, buildings should be sited approximately half to two-thirds of the way up the side of slopes, so that they are not exposed to the high winds over the ridges nor in areas susceptible to damp and frost as found in valleys.

INFLUENCE OF TOPOGRAPHY ON SITE SELECTION

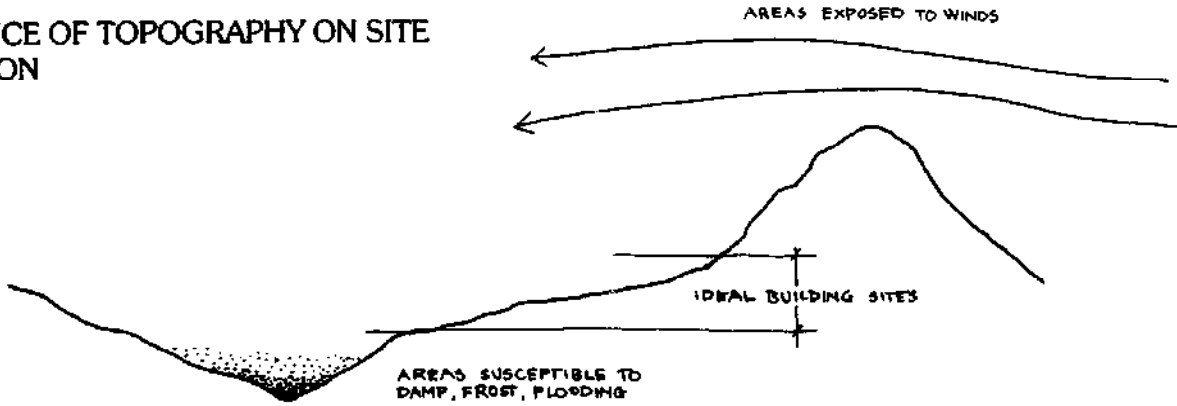

ORIENTATION AND ANGLE OF SLOPE

Because of the apparent motion of the sun with respect to any particular point, the aspect or orientation of a site as well as its angle of slope will significantly influence the site micro-climate, which will, in turn, affect both building and landscape performance.

Sites receiving more direct sunlight in winter tend to be warmer and less prone to frosts, while sites receiving more radiation in summer tend to overheat.

The amount of sunlight received on a site will also influence soil temperature and consequently will alter the growth rates and patterns of plant material, e.g. deciduous trees on northerly slopes will lose their leaves later and regenerate new leaves earlier than similar plants grown on southern slopes.

EXISTING VEGETATION

The value of existing vegetation can be threefold: deflection of winds over the site, provision of sheltered micro-climate, and control of possible erosion on the site.

These elements will be discussed in a later section, but it should be stressed that any clearing which occurs should be carried out judiciously so as not to upset the local ecology. The felling of trees for building purposes should be carried out in such a way as to minimise physical damage to other vegetation and loss of canopy shade. The probability of exotic weeds becoming established in an area increases when the upper crown is disturbed since competition between plant species in the early regeneration stage is fierce.

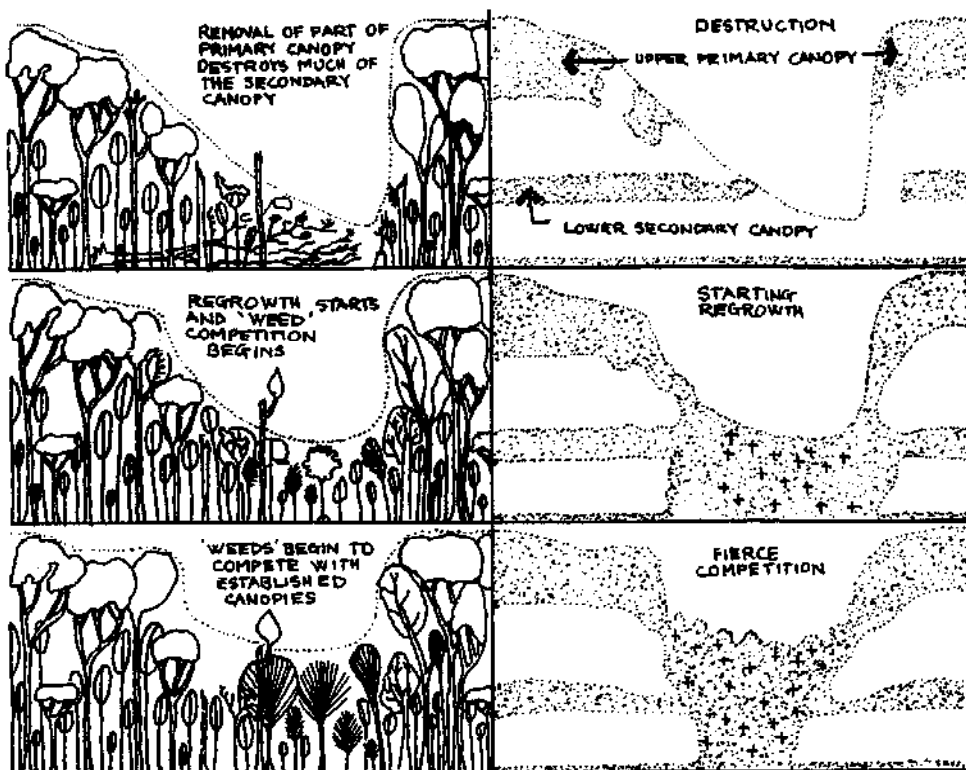

IMPACT OF TIMBER SELECTION FROM NATURAL FORESTS
ALL BUILDING TIMBERS SHOULD BE TAKEN FROM TREES IN THE LOWER SECONDARY CANOPY.

PROTECTED OR SHELTERED VERSUS EXPOSED AREAS

Two aspects to be considered at this stage are protection from winds, and protection from convective air currents which may bring frosts and fog.

Areas exposed to high winds should be avoided since they will cause any building to lose heat rapidly in winter. Areas receiving cooling summer winds, however, are most desirable.

Another feature to be considered in this section is the vulnerability of a site to wind-blown bushfires (Foster, 1976). Serious bushfires are invariably driven by winds from predictable wind directions. Consequently, some sites will be found to be fully exposed to such winds, while others lie in wind shadows.

A suitable method for examining the effects of winds and bushfires on a site is, once again, to examine the existing vegetation. Areas that are exposed to high winds will frequently have vegetation that is either stunted, with hard leathery leaves, or displaying a large number of broken branches and limbs. The soil in these areas will generally be dryer. Areas receiving less violent winds or those which lie in wind shadows will have soil with a higher moisture content and will be colonised with plants having softer, more delicate leaves. Areas more likely to be affected by bushfires invariably show scars of previous bushfires or will be dominated by pioneer species.

Convective air currents, while not of great importance in warmer areas, will again affect both building and landscape development. Since cold air is heavier, it settles into the lower areas and flows down the valleys unless impeded by land forms or massive blocks of vegetation. Sites in the direct path of this colder air, or located in the valleys themselves, are obviously less suitable for both energy conservation and solar energy utilisation.

1. See FOSTER, Ted: "BUSHFIRE: History, Prevention, Control" SYDNEY, REED: 1976

Landscaping for Energy Conservation

Landscaping can form an important, if not integral, element of any energy conservation system and should be considered at the outset of the building project.

Through the judicious siting and selection of plants, the immediate micro-climate around the building can be significantly altered. Plants are able to modify the micro-climate by sheltering the building from undesirable winds, while deflecting desirable winds through the building, and by controlling the amount of solar radiation striking the building. Plants both intercept and absorb solar radiation, then use the absorbed energy in growth and temperature control. The plants affect temperature by transpiration of water which can cool the surrounding environment.

For vegetation to be successful, plant material should be chosen according to the following criteria:

- deciduous or evergreen
- complete or incomplete canopies
- leaf distribution — vertically hanging leaves through to horizontal leaves
- transpiration capabilities — high transpiring plants or low transpiring plants.

The first three points can be ascertained by inspecting the mature plant material, while a rule of thumb can be used for the fourth. Plant materials with a low transpiration rate are generally considered as drought tolerant plants and are usually characterised by some modification to the leaf structure: for example the leaves may be small, leathery, have fine hairs or have a waxy quality.

Landscape integrated design can take many forms, but its simplest application can be considered in four main areas:

- windbreaks and shelterbelts
- the use of plants near buildings
- the use of vines
- sod or turf roofs, and earth sheltered designs.

WINDBREAKS AND SHELTERBELTS

These can be used to deflect and direct winds to the advantage of a dwelling. The wind shadow effect of a vegetation barrier extends some 10 to 15 times its height to the lee of the windbreak, and hence this protected zone makes a good building area in places where wind effects are undesirable.

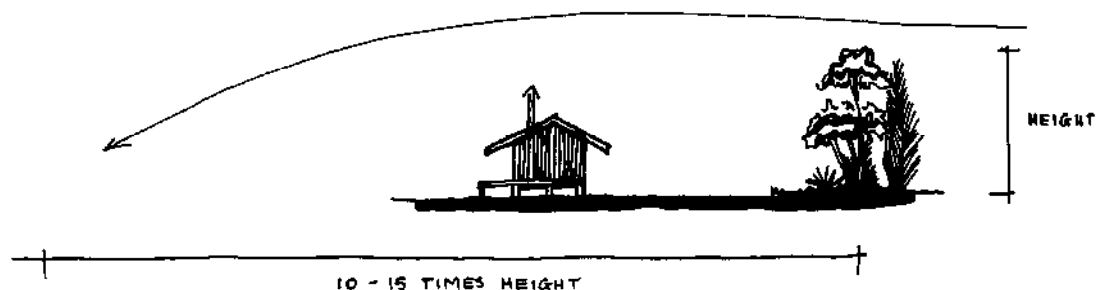

POSITIONING OF BUILDINGS IN RELATION TO SHELTERBELTS

SHELTERBELTS FOR HOT CLIMATES

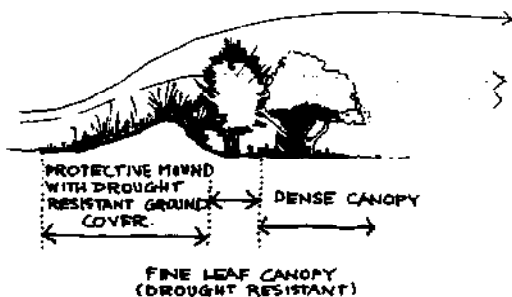
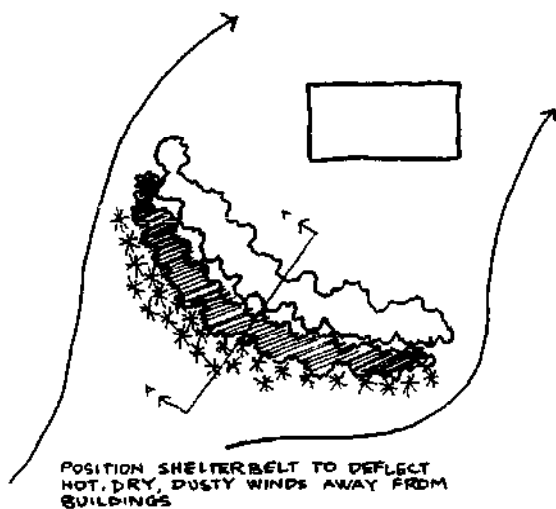

Shelterbelts in hot climates should incorporate the following points:

- The outer vegetation should be drought resistant and grown on a earth mound.
- The canopy should extend close to the ground; therefore use shrubs and ground covers.
- The canopy should be porous - do not use dense canopies.
- Avoid openings in the canopy.
- Vegetation on the house and lee side of the shelterbelt should be broad leaved and well sheltered. (Link in with absorption trench.)

SHELTERBELTS FOR COLD CLIMATES

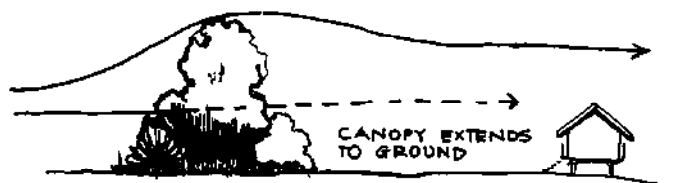
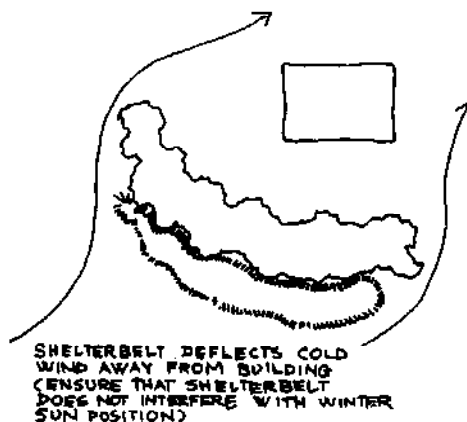

Shelterbelts in cold climates should be positioned so that they deflect cold winds around and over the building. Trees used for such purposes should be evergreen.

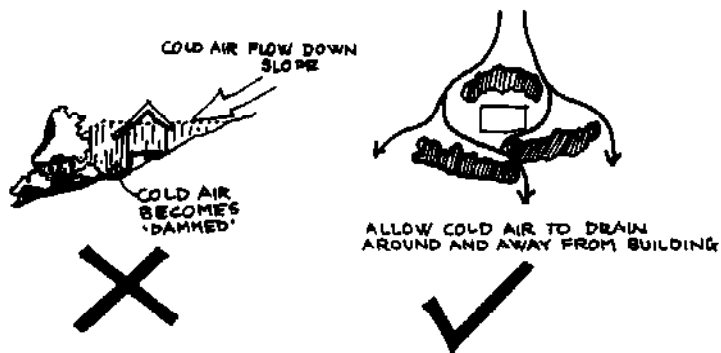

Care should be taken when using shelter belts on sloping sites where they may also act as a dam to the movement of cold air. In such situations, the shelterbelt should be staggered to allow cold air to drain away from the building.

THE USE OF PLANTS NEAR BUILDINGS

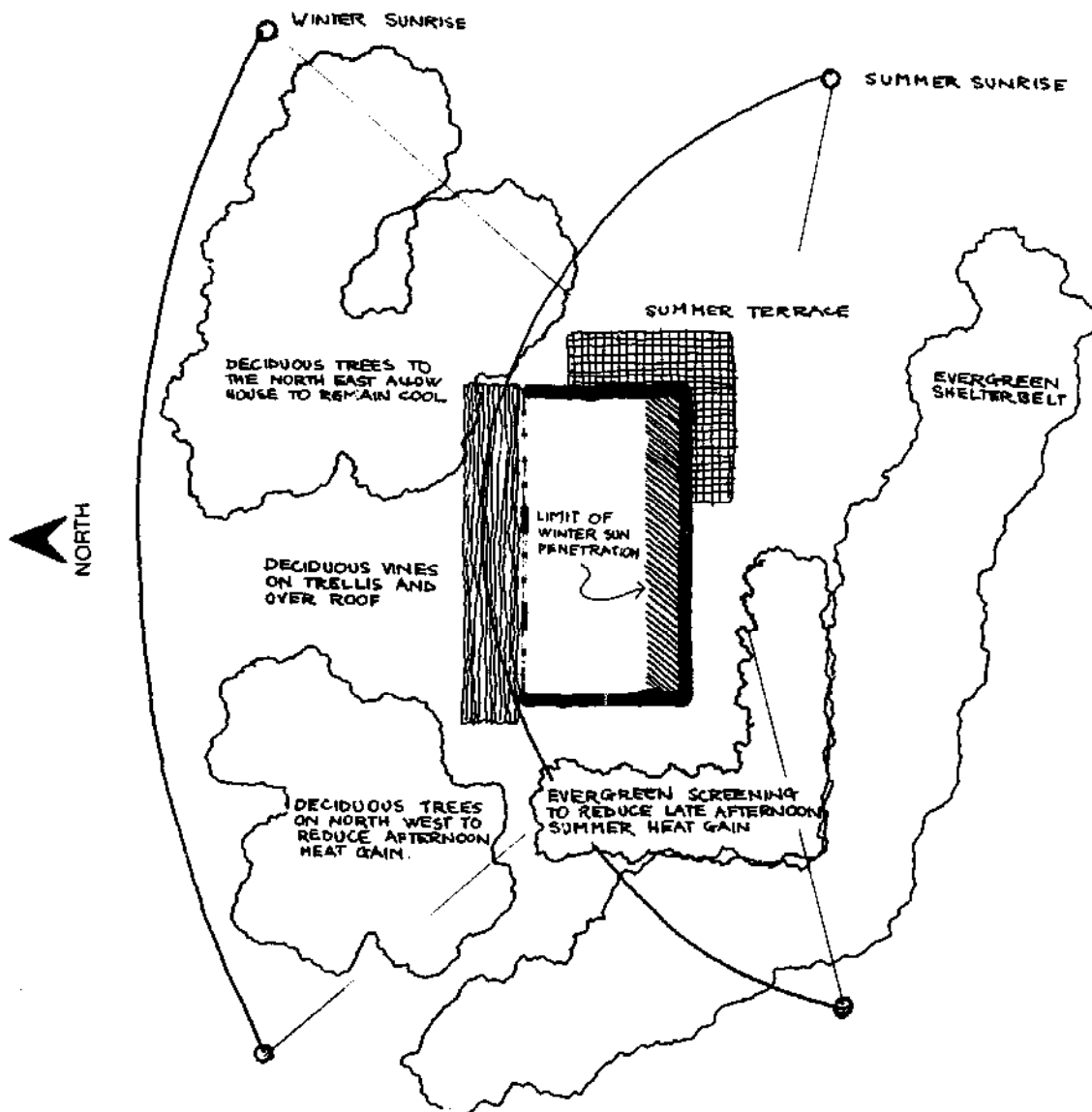

LOCATION OF PLANTS FOR SUN CONTROL

The illustration shows how deciduous and evergreen planting can be used around a building to admit or screen solar radiation from season to season.

Generally, the zone of planting between the north-eastern and north-western sectors (corresponding to the winter sunrise and sunset), should be deciduous, to allow sun penetration in winter while excluding hot summer sun. The zones corresponding to the summer sunrise and sunset (south-east and south-west) should be planted with evergreen species to screen the building from the early and late hours of summer sunshine.

The high altitude of the summer sun means that deciduous trees and sunshades can screen a building in the hotter months, while allowing the lower angle radiation in winter to enter the dwelling.

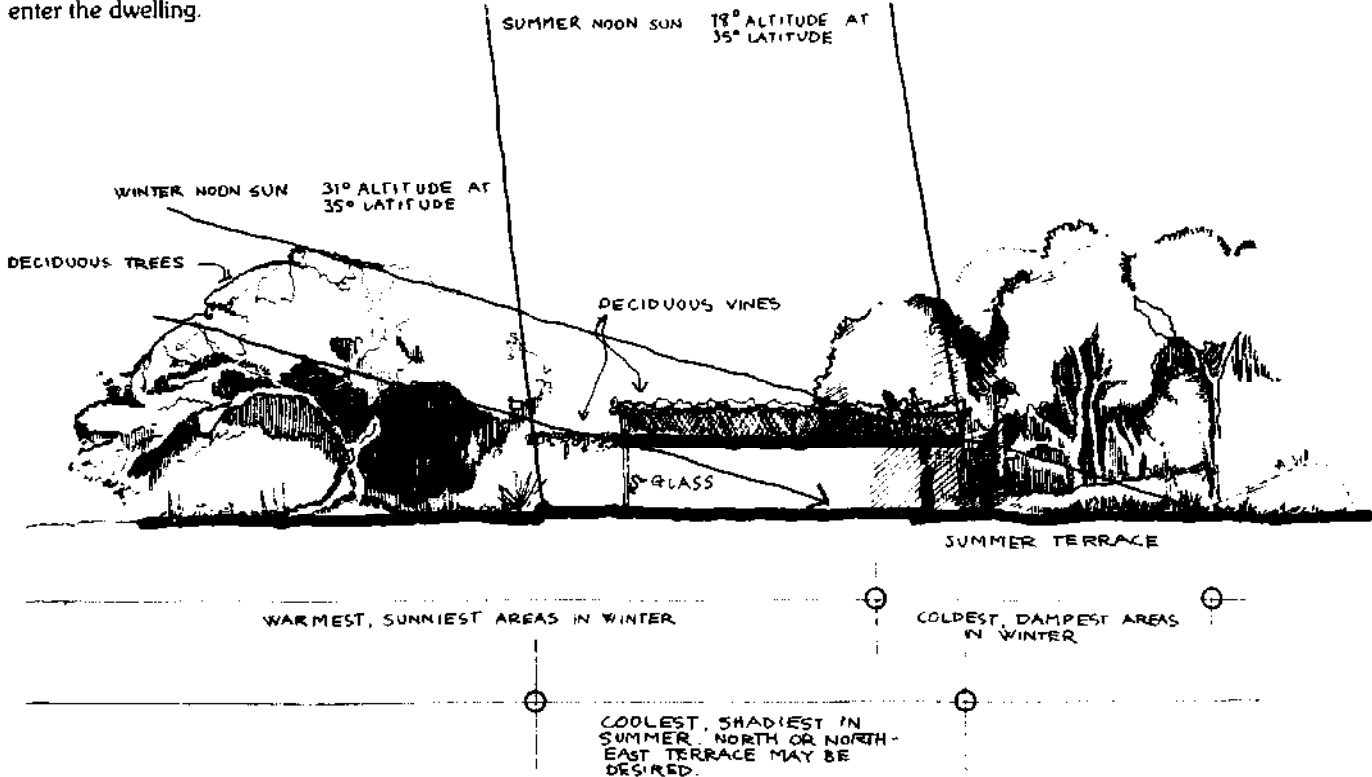

THE RANGE OF SUMMER TO WINTER SUN PENETRATION

Landscaping can be used to cool buildings in summer by setting up cool zones around a building

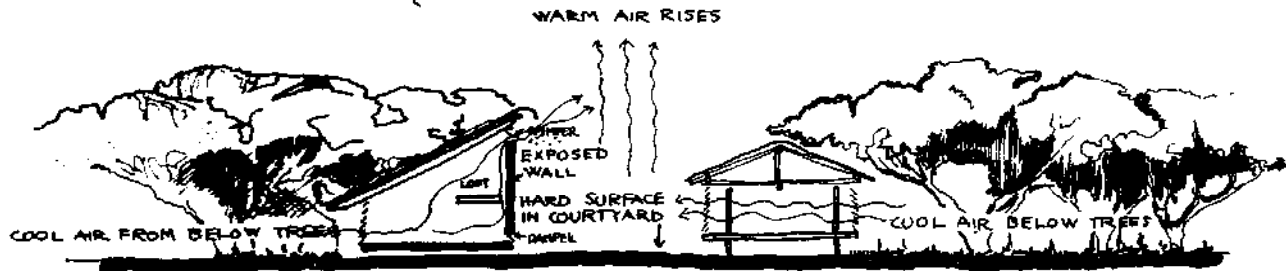

THE HOT AIR IN THE CENTRAL COURTYARD RISES BRINGING COOL AIR FROM BENEATH THE TREES INTO THE BUILDINGS.

WARM AIR ESCAPES FROM BUILDING AND GLASSHOUSE STRUCTURE

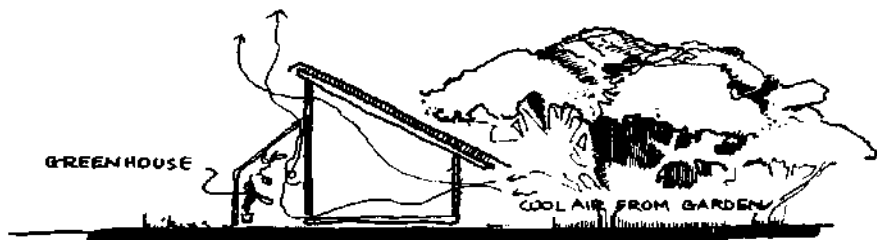

THE HARD SURFACE OF THE COURTYARD IS REPLACED BY A GREEN HOUSE WHICH CAN BE USED FOR WINTER HEATING OF THE BUILDING.

LANDSCAPING FOR SUMMER COOLING

THE USE OF VINES

Vines growing on or near a wall can reduce heat gain into a building by as much as 70 per cent, as well as reducing heat loss by 30 per cent. It can therefore be considered as an option to insulation.

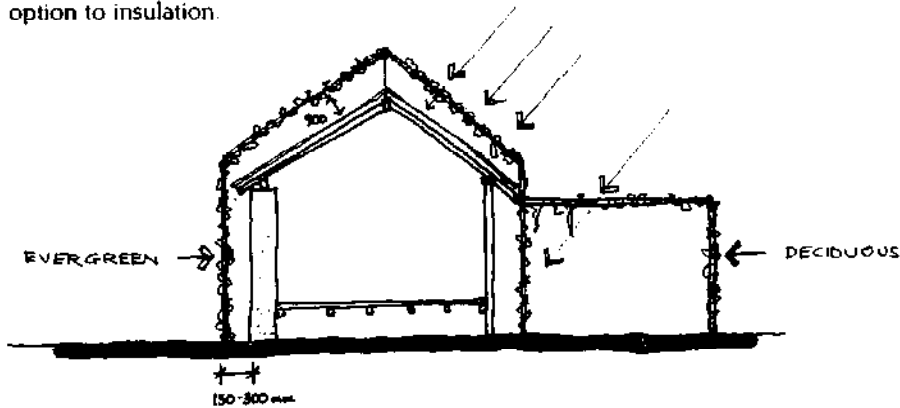

VINES CAN BE EXTENDED FROM A PERGOLA TO GROW OVER A BUILDING

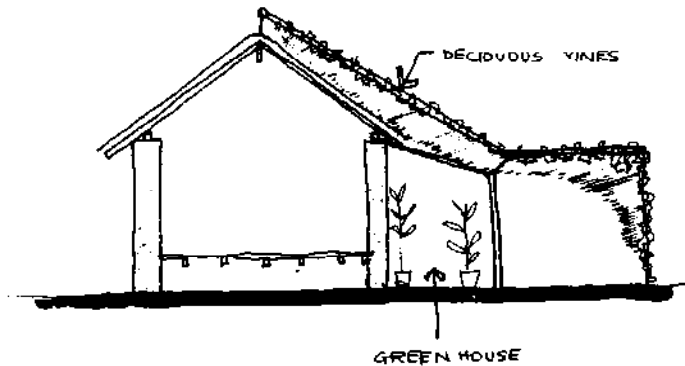

GREEN HOUSES USED TO HEAT THE BUILDING IN WINTER CAN BE MADE COOL BY USING A DECIDUOUS VINE

THE USE OF VINES FOR INSULATION

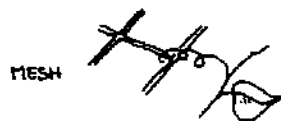

SOLID SUPPORT e.g. TIMBER



NOTE: If vines are to be grown directly on a wall, choose both plant and materials carefully, e.g. do not use vines directly on earth walls (use a supporting structure away from such walls). Provide support structure consistent with the plant's climbing mechanism.

Climbing mechanism	Support structure	Examples
Tendrill	mesh	Grape (vitis species)
Twiner	timber struts	Honeysuckle (lonicera species)
Scrambler	solid support e.g. timber	Bougainvillea species
Climbing	sucker pads	Parthenocissus species

Note: Vines should be planted at small intervals to promote vertical growth. Walls and roof not facing north should use evergreen vines.

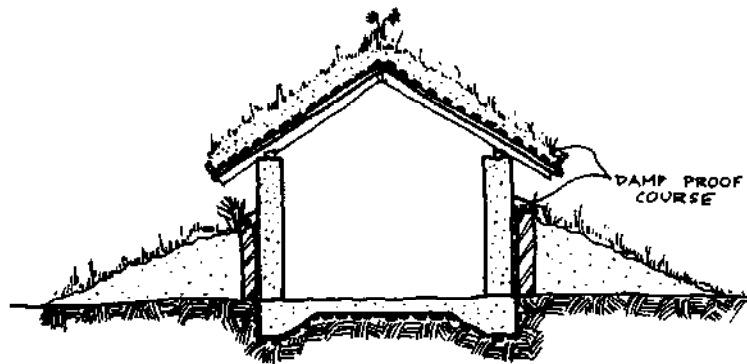

USE OF SOD CONSTRUCTION FOR INSULATION

SOD OR TURF ROOFS

A sod roof should have a minimum depth of 150 mm, with 200-300 mm being the optimum for roof constructions. The shallower the soil, the more water will be required for healthy plants. Greater depth of soil will require substantially more support, and an engineer's advice on the roof structure may be necessary.

Local soils are generally suitable unless they have a very high clay content. Sandy clay loams mixed with at least 20 per cent organic matter are ideal, as the compost will improve the water holding properties of the soil.

Roof slopes should be in the range of 5° to 27°, as greater slopes tend to cause soil slippage. If seed is to be sown on the soil, the roof should slope no more than 16°, and a soil binding grass (e.g. sub-clover) should be mixed with the desired cover seed. Cut turf may also be laid directly on the roof and then watered thoroughly. Local drought-resistant field grasses make good cover, while domestic turf grasses should be avoided as they require too much water. If shrubs are to be included, plant them at the base of the roof, where there will be more moisture available.

The roof should be carefully waterproofed with a membrane. Butyl rubber is ideal but costly. Another membrane available is Sarlon-Polyfabric.

Thermal Design Concepts

This section is a companion to the previous outline on the way landscaping can modify environment, and aims to give the homebuilder some idea of the way different materials and construction techniques work together to keep buildings comfortable throughout the seasons.

Lightweight building materials such as corrugated iron respond very quickly to temperature fluctuations, heating very quickly by day and cooling quickly by night. Massive building materials, like earth walls on sod roof forms, will heat up comparatively slowly and lose heat less rapidly at night.

In areas that experience a wide range in day to night temperatures, the use of lightweight materials could result in overheating by day and excessive cold by night. In such areas, it would be more reasonable to use more massive components which would cause a levelling of night and day temperatures.

Hot, humid areas, however, generally only require massive elements on the floor, e.g. a concrete slab in contact with the ground. Further detailed information on the thermal performance of building materials is covered in *Designing Houses for Australian Climates*. (Bulletin No. 6, Experimental Building Station).

THERMAL INSULATION

Insulation slows the transfer of heat from a source to its surroundings, and hence has value in preventing heat loss in winter, and heat gain in summer, from a building, thus rendering interior temperatures more comfortable to the occupants.

Significant heat loss and gain occurs through the roof, and it is generally considered good practice in all of New South Wales to insulate the ceiling space. The effectiveness of wall or floor insulation depends on the climatic region, type of construction and other factors, and is not necessarily justified in warmer areas though it may assist in the weatherproofing of "windy" constructions.

Insulating materials fall into two broad categories — reflective (e.g. aluminium foil) and bulk (e.g. fibreglass batts). Reflective insulation is slightly superior for minimising summer heat gain, while bulk insulation is more effective in preventing winter heat loss.

The positioning of insulation within wall and roof cavities requires care, as incorrect placement can be less effective and cause problems with rot, condensation, etc. Reflective insulation should be applied close to the warm or indoor side of the construction to minimise condensation in areas where frosts occur. The foil gains efficiency by having a layer of still air on either side, and hence construction where this is provided will perform more effectively to limit heat transfer — for example, slightly draping foil that is fixed over battens, but directly under sheet roofing.

Depending on the insulator used, about 50 mm of bulk insulation is considered adequate in most parts of New South Wales. Fibreglass batts are commonly available, though a variety of other materials can be used, such as natural wool, cane products, straw and thatch, kapok, cork, dried seaweed, etc. Insulation need only be as fire-resistant as the rest of the structure, except around flue pipes and other heat sources where fire resistant materials should be used.

Room Sizes

The Ordinance requires that Class I buildings should be provided with:

- 1) A kitchen or facilities in another room for the preparation and cooking of food;
- 2) a bath or shower;
- 3) clothes washing facilities;
- 4) toilet facilities.

A single dwelling house having only one habitable room not counting any fully enclosed kitchen should have a minimum floor area of 18.5 square metres.

If space for the preparation of food is included in this room the area must be increased to 21.5 square metres. If a bathroom, shower room, clothes washing facilities and/or a toilet are provided in rooms they may be either attached to or detached from a single dwelling house and should have the following minimum areas:

- Bathroom 2.2 square metres
- Shower room 1.1 square metres
- Clothes washing 1.1 square metres
- Toilets 0.7 square metres

Clothes washing facilities may not be in a kitchen or food preparation area.

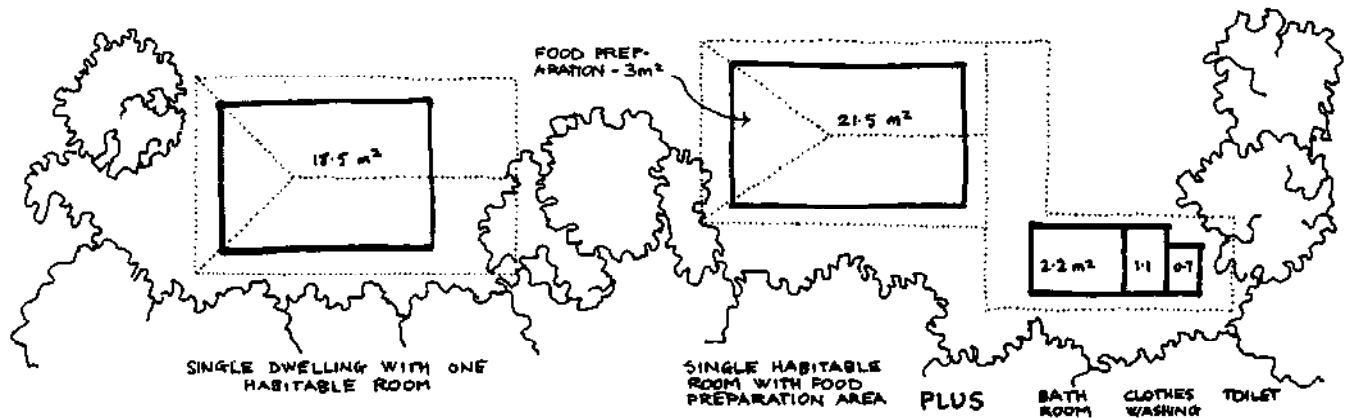

MINIMUM ROOM SIZES

In a single dwelling house having more than one habitable room, at least one room should have a minimum floor area of 14 square metres, a second room should have a minimum area of 11 square metres and any other rooms should have a minimum area of 7.5 square metres.

If a space exclusively set aside for the preparation of food is included in any of these rooms, the area must be increased by 3 square metres. No restrictions in floor area apply to fully enclosed kitchens.

The sizes of attached or detached bathrooms etc. provided in rooms are referred to above.

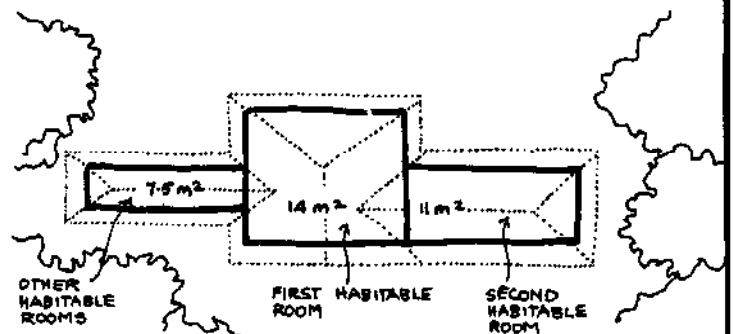

(SIZES OF NON HABITABLE ROOMS AS PER PREVIOUS SECTION)

ROOM SIZES FOR SINGLE DWELLING WITH MORE THAN ONE ROOM

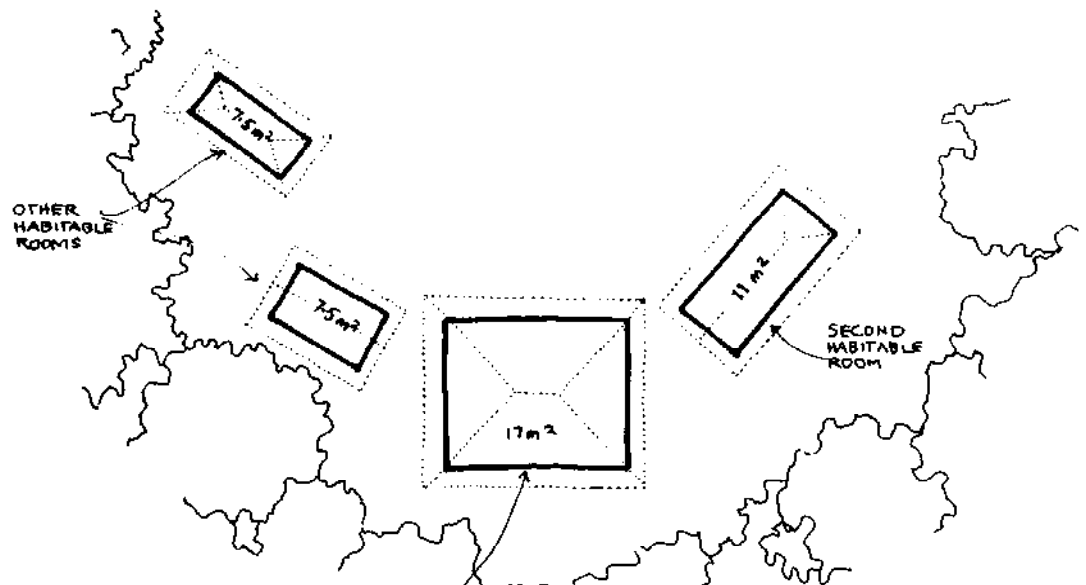

FIRST HABITABLE ROOM 14m²
 PLUS FOOD PREPARATION + 3m²
 17m²

ROOM SIZES FOR AN EXPANDED HOUSE

In an expanded house having shared facilities the same minimum floor area requirements as set out above apply. Where space exclusively set aside for the preparation of food is provided in any of these rooms the resulting minimum areas would be either 17, 14 or 10.5 square metres.

Heights of Rooms

Habitable rooms should have, over two-thirds the floor area, a ceiling height of at least 2400 mm. Non-habitable rooms should have a ceiling height of at least 2100 mm over two-thirds the floor area. In neither case should the ceiling height be less than 1500 mm except where a wall of the room is not perpendicular to the floor. In this case the floor area with a ceiling less than 1500 mm is not taken into account for the two-thirds calculation.

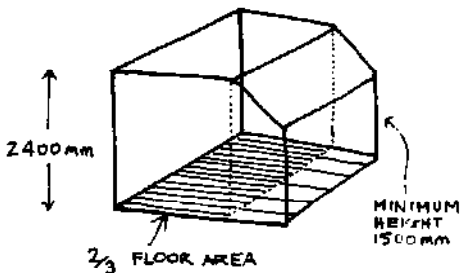

HABITABLE ROOMS

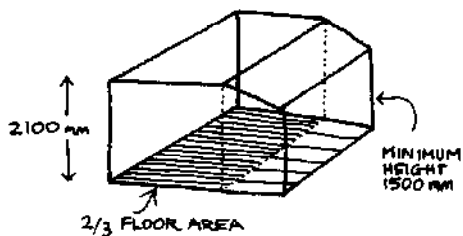

NON-HABITABLE ROOMS

MINIMUM CEILING HEIGHTS

MEZZANINE FLOORS

Where a mezzanine floor is provided (Part Two, Definitions) the ceiling height above and below the mezzanine is not included in the restrictions set out in 16.3. The maximum area of a mezzanine as a proportion of the floor below it is not specified, but this publication recommends that it not exceed two-thirds of the lower floor. Regulation 41 of the Public Health Act requires sleeping areas to have a minimum available air space of 14 cubic metres per person.

In addition, a means of escape should be provided from mezzanines or second floor areas, directly to the outside of the building — for example, through a window to a lower roof, thence to the ground.

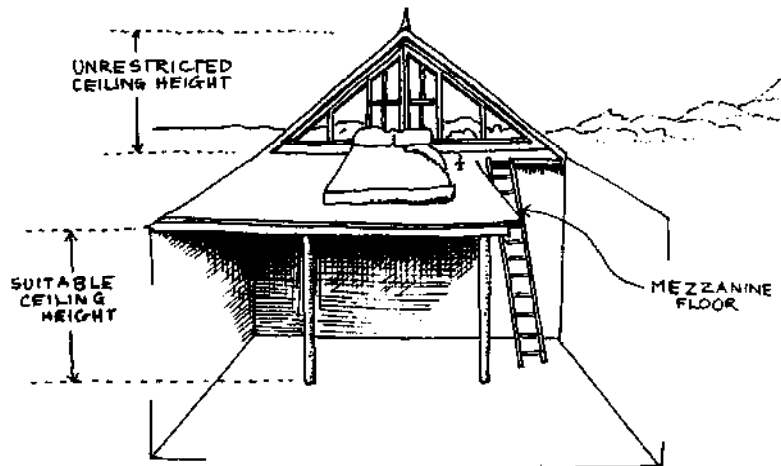

CEILING HEIGHTS WITH MEZZANINE FLOOR

Light and Ventilation

The Ordinance requires that habitable rooms be provided with windows "having an aggregate light transmitting area of not less than one-tenth the floor area of the room concerned" (Part 50.2(2)) and with "permanent openings, windows, doors or other devices which are capable of being opened, having an aggregate opening or operable size of not less than one-twentieth the floor area of the room concerned" (Part 50.8(1)). Where a room has no openings to the exterior, but opens into another room or enclosed verandah, it must have the same openings as above, and the adjoining room must have openings providing for one-tenth of the combined floor areas for light transmission, and one-twentieth of the combined floor areas for ventilation.

Workmanship

There is little guidance in the Ordinance concerning the very important aspect of workmanship. Clause 10.1 states: "Every part of a building shall be erected in a good and workmanlike manner."

This handbook assumes that the owner-builder, while perhaps lacking the specialised training and experience of many builders and tradespeople, will make up for any deficiency through the caution and care which will be exercised by those who have to live with the consequences of their own design decisions and handiwork.

Well-executed work is obviously desirable, be it sophisticated and expensive, or low cost using sound recycled materials. Principles such as anticapping, water shedding, subfloor ventilation, adequate bracing and maintenance are fundamental to the furthering of a building's natural life, which makes sense in an era of growing resource scarcity and pressure.

Do it once, and do it well!

Materials

CHOICE OF MATERIALS

The choice of materials is intimately bound up with the task required to be performed, over what period of time, and the manner in which they can be put together so that "a good and workmanlike" job can be executed, for the reasons previously mentioned.

Information concerning the properties and detailing of building materials is widely available, though the use of different materials and techniques varies from region to region.

In general, homebuilders should try to maximise the use of local building resources, to the extent of retrieving materials from their own sites, such as earth or round timber poles.

QUALITY OF MATERIALS

Materials, either new or second hand, which are dangerous to health, faulty or unsuitable (Ord. 70 Part 10.2) should not be used in the construction of a building, e.g. hazardous materials containing toxic substances, timbers from disused mines, or materials that have been used in the construction of a cesspit, drain or sewer.

The Council itself may test any material used or proposed to be used, or may require documentary

evidence in the form of a report from a competent testing authority such as the Commonwealth Scientific and Industrial Research Organisation, an Accreditation Certificate from the Director of the Experimental Building Station, or any other form of documentary evidence which in the opinion of the Council is satisfactory.

Many materials are required to conform with Australian Standards — see Appendix 9 for the appropriate Standards and Codes of Practice.

RECYCLED MATERIALS

Homebuilders may consider using sound secondhand and recycled materials and components. Demolition sites may provide structural members, cladding, roofing, doors, windows, flooring and other joinery. These should be repaired, made good and trimmed as necessary.

OTHER MATERIALS

Certain materials may be used to provide short term waterproofing or as temporary enclosure in staged construction. Any long term use of these materials, with replacement as necessary should be negotiated with the building inspector.

STRUCTURE

This section deals with some of the factors homebuilders should consider regarding the choice of structure for any dwelling. It is not intended as a design guide to the characteristics of different structural systems as such a guide is beyond the scope of this handbook, but rather as an indication of the factors influencing the choice of structure, and the structural principles involved in making a building sound.

Factors Influencing Choice of Structure

- 1) Appropriateness of a structural system in providing roof, floor or wall spans consistent with the desired room layout.
- 2) The local availability of structural materials, or the logistics involved in transporting different materials to remote sites.
- 3) Initial costs of different structural materials, and the amount of skilled or unskilled labour and plant required to erect or fix them.
- 4) Ability of a structural system to provide shelter before the completion of all construction up to the roof level (e.g. load-bearing masonry needs to be completed before roofing can be commenced).
- 5) Environmental considerations regarding the ethics of materials production; energy content, durability and maintenance requirements; recyclability; local vernacular; ease of adaptation to changing living patterns; and so on.

Structural Principles

The homebuilder should answer two basic questions in relation to the structural soundness of a building:

Is the arrangement of structural members a stable arrangement?

What is the required size of each structural member?

Structural members include beams, columns, bearers,

joists, stumps, and wall studs.

(a) Beam

A beam is a structural member which is much longer in one direction than in the other two directions and is usually placed so that its long dimension is close to the horizontal. Floor bearers, floor joists and rafters are examples of beams.

(b) Column

A column is a structural member which is much longer in one direction than in the other two directions and is usually placed so that its long dimension is close to the vertical. Footing stumps, wall studs, poles in vertical positions are examples of columns.

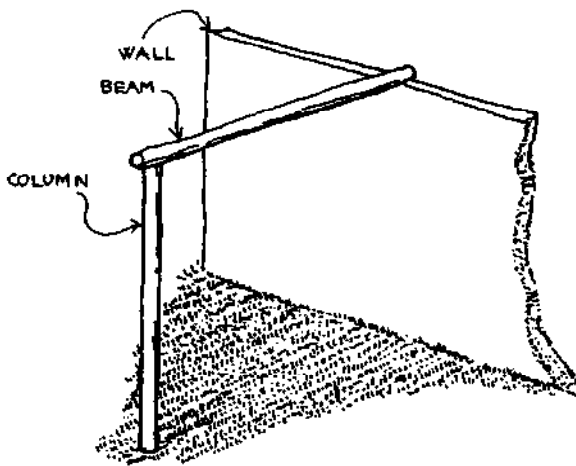
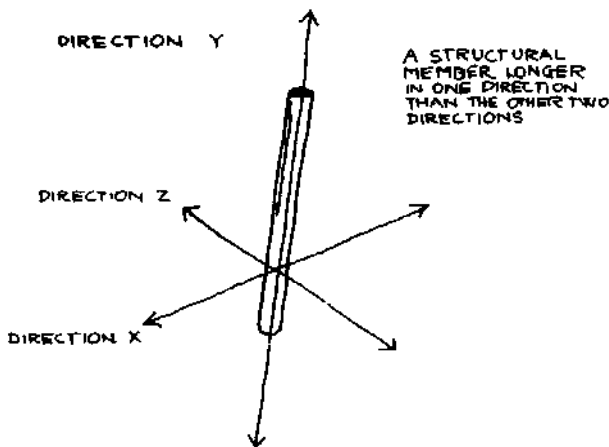

Before the size of structural members can be chosen the structural members must first be arranged together to form a stable structural arrangement. The structural arrangement can influence and be influenced by the planning of the building.

STABILITY

Fixed joints (see definition below) are often difficult to achieve. Pinned joints (see definition below) are easier. The technique outlined below for achieving stable arrangements relies mainly on pinned joints but also works with fixed joints.

The process of achieving a stable structural arrangement is in two parts. First, stable planes are made from which stable structural arrangements are then made.

Definitions:

A *pinned joint* joins two or more structural members together at one point but allows rotation of the structural members relative to one another.

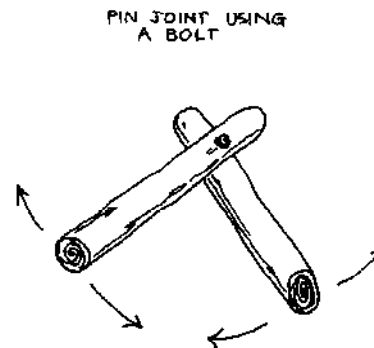

A *fixed joint* joins two or more structural members together at one point but does *not* allow rotation of the structural members relative to one another.

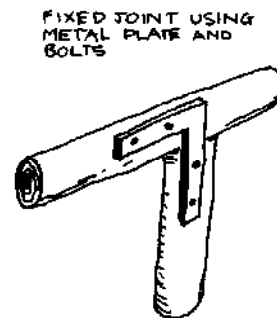

A *stable plane* is an arrangement of structural members in one plane such that the arrangement will retain its own shape. Examples of stable planes are given below. An example of an arrangement which is *not* stable is four pieces of timber arranged in a rectangular shape with one bolt at each joint — it will not resist being pushed into another shape. (It can be useful to test the stability of structural arrangements by modelling them with drinking straws and pins.)

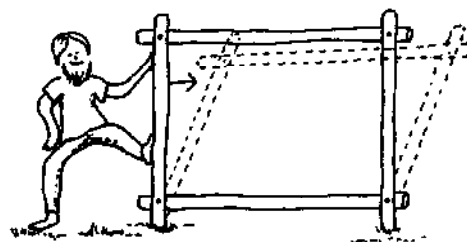

STABLE PLANES

There are many possible arrangements of structural members which will produce stable planes. The following examples are stable planes:

(a) A triangle with pinned joints.

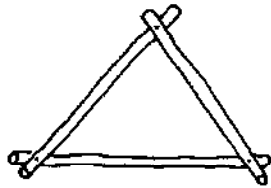

(b) Any plane which is made up of triangles — all joints being pinned.

The diagonal members are often called "bracing".

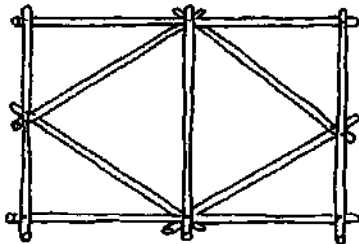
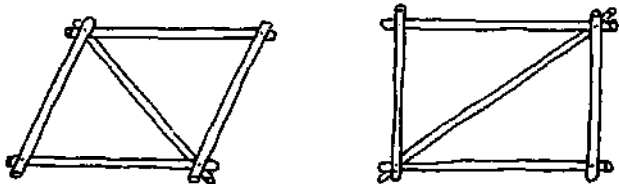

(c) A rectangle with at least one fixed joint, all other joints pinned.

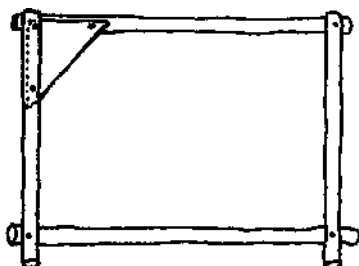

(d) Any shaped polygon with at most three pinned joints.

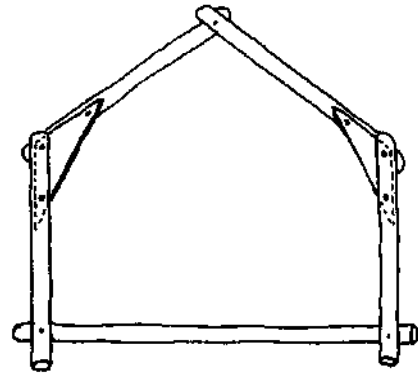

(e) A knee brace has a similar effect to a fixed joint. Therefore any rectangle with at least one knee brace is stable. Any polygon with at most three pinned joints with all other joints having knee braces is stable.

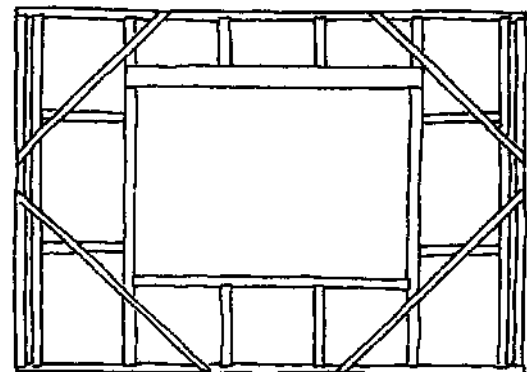
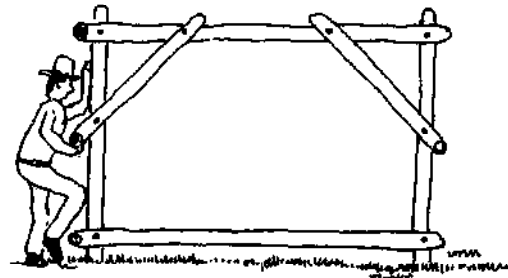

(f) Walls of brick, mud brick, stone masonry and plywood panels are stable planes.

(g) Use of infill panels of brick, mud brick, stonemasonry, plywood panels, tongue and groove boards on timber frames make stable planes.

(h) Poles set in the ground are stable in all directions. The connection to the ground is a fixed joint and rules (c) and (d) above can be applied.

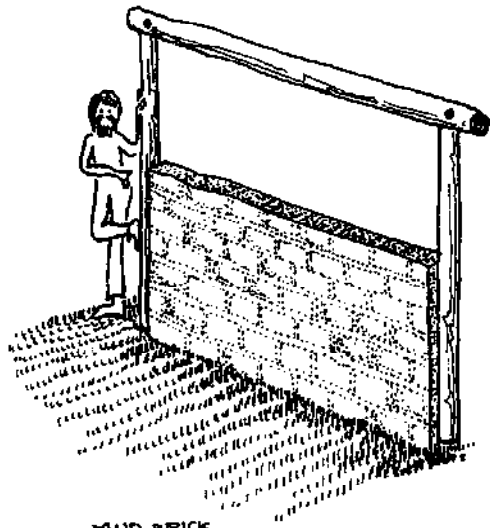

MUD BRICK
WALL INFILL

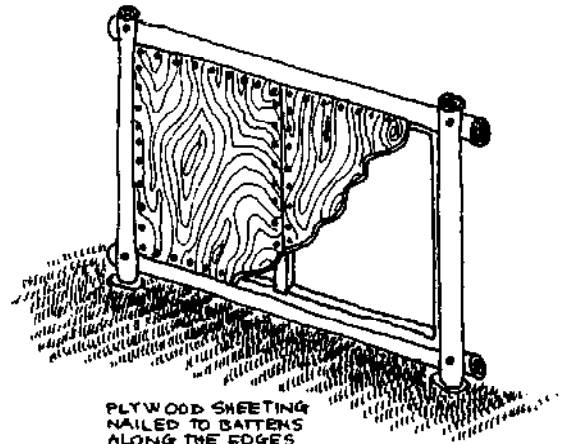

PLYWOOD SHEETING
NAILED TO BATTERS
ALONG THE EDGES

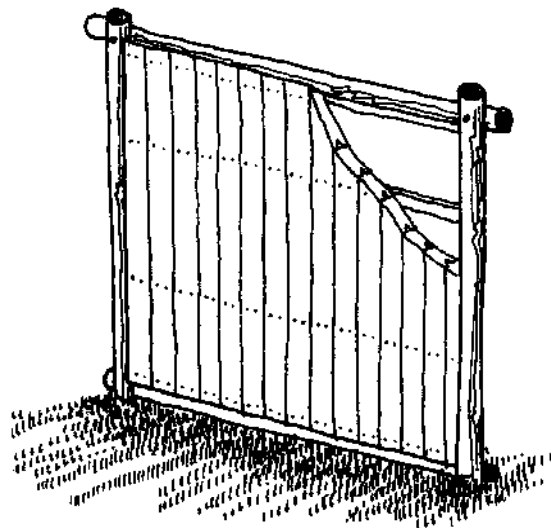

TONGUE AND GROOVE
BOARDING INFILL

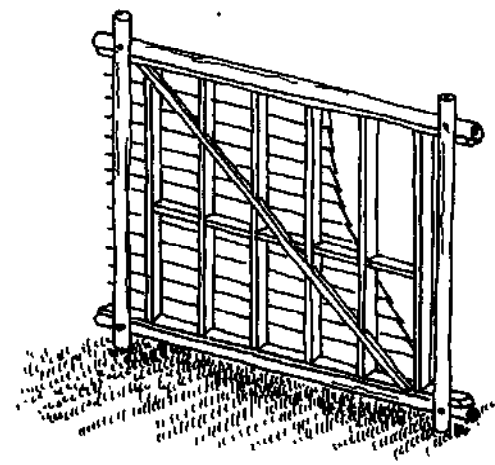

STUD FRAME

STABILITY RULES

How to make a stable building using stable planes:

Rule 1. A building of rectangular plan with flat roof (not necessarily horizontal), where the ground is the floor, is like a box which has six planes defining its volume. One of the planes is the ground which is a stable plane. There are five remaining planes.

Four of the five remaining planes must be stable planes.

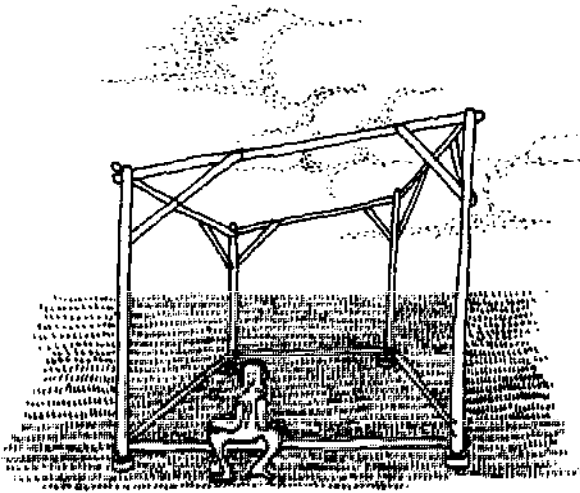
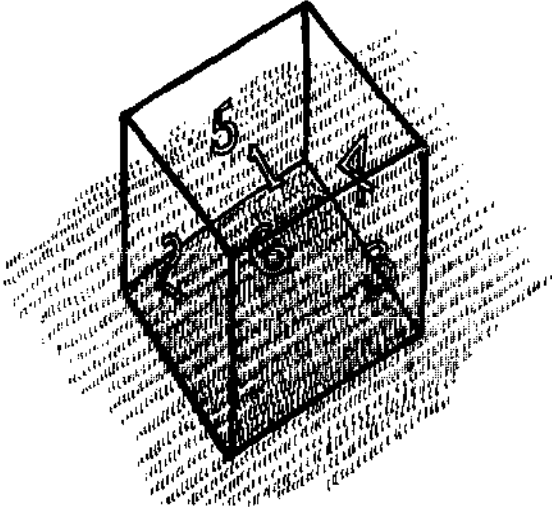

STABLE

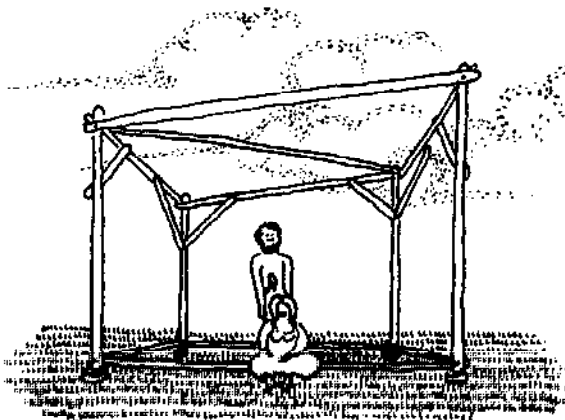

STABLE

Rule 2. For a building of rectangular plan with a flat roof (not necessarily horizontal) where the ground is the floor and where internal and/or external walls provide stable planes:

The roof plus three of the non-intersecting walls must be stable.

(“Non-intersecting walls” means the three walls do not have a common line of intersection.)

NOT ACCEPTABLE

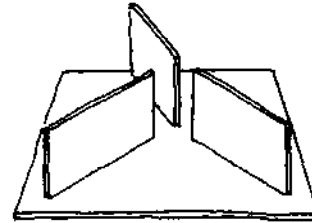

INTERSECTING WALLS

ACCEPTABLE

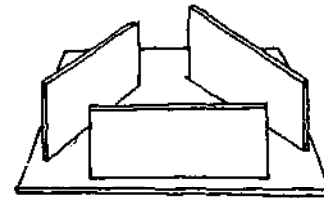

NON INTERSECTING WALLS

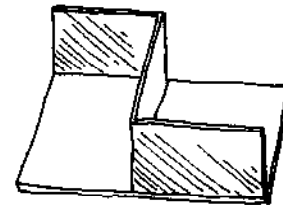

AERIAL VIEW OF
STRUCTURE BELOW

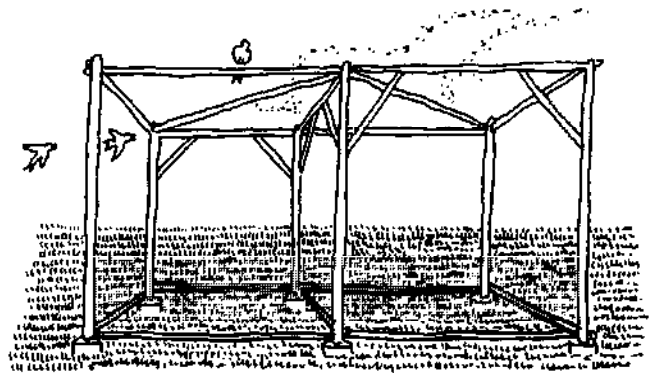

Rule 3. For a building of any plan shape with a flat roof (not necessarily horizontal) where the ground is the floor:

- either *The roof plus any three non-intersecting walls are stable planes*
- or *The roof is not a stable plane and all the external walls are stable planes.*

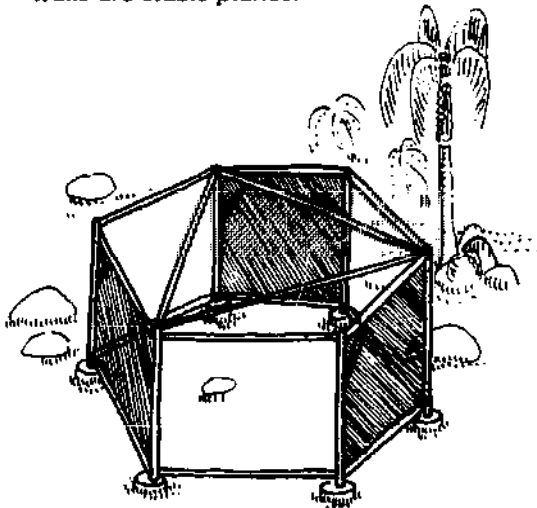

3 WALLS STABLE AND ROOF STABLE

Rule 4. Additions to a stable building may be made by means of:

- either *A stable roof plane plus columns pin jointed top and bottom*
- or *A stable vertical plane placed so that it is not at right angles to the stable portion plus beams connecting it to the stable building.*

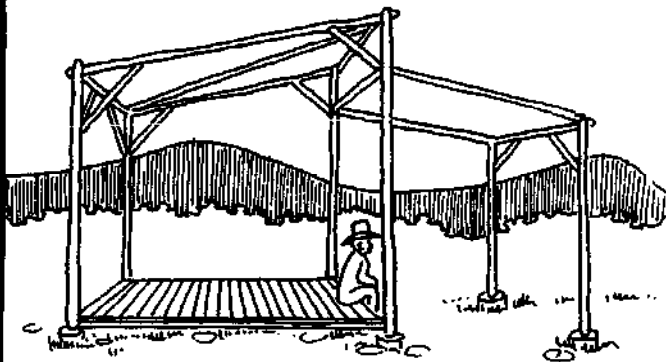
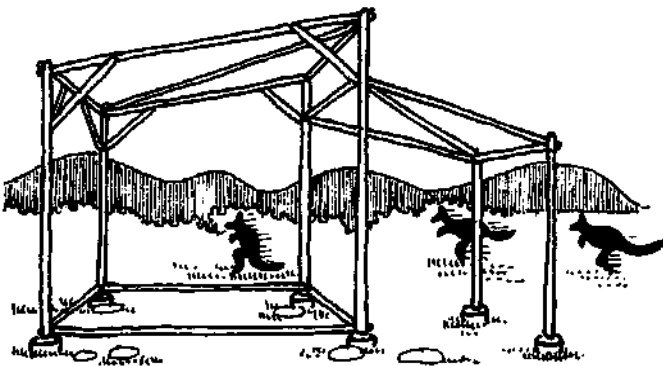

APPLICATION OF STABILITY RULES

(a) To a typical single storey building with suspended floor:

This type of building is treated by the rules as a two storey building. The "first storey" exists between the ground and the suspended floor. The "second storey" exists between the suspended floor and the roof.

Apply rules 1 to 3 (as appropriate) to the "first storey" considering the suspended floor as the roof. This process leads to stability between the ground and the suspended floor.

Now the suspended floor can be considered to be the ground and apply rules 1 to 3 as appropriate to the "second storey".

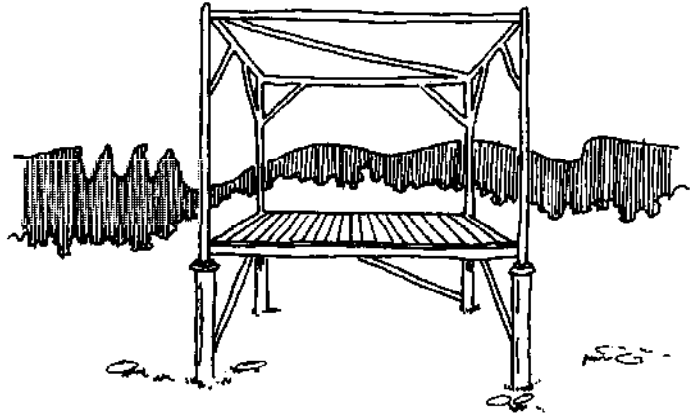

(b) Special single storey case:

Where the columns are connected to the ground by **FIXED** joints and pass without interruption, for example by ant caps, to the roof then the building is a stable arrangement.

(c) To a typical two-storey building:

This building can be treated by the rules as a three-storey building. The "first storey" exists between the ground and the first floor. The "second storey" exists between the first and second floors. The "third storey" exists between the second floor and the roof. The process outlined in (a) above is simply continued one step further by applying rules 1 to 3 as appropriate to the "third storey".

(d) To a building with pitched roof:

All external surfaces must be arranged as stable planes unless a portion of the building is arranged to be stable so that the remainder can be accommodated by Rule 4.

In this example the area below the roof is stable by Rule 3. The roof is made stable by Rule 4.

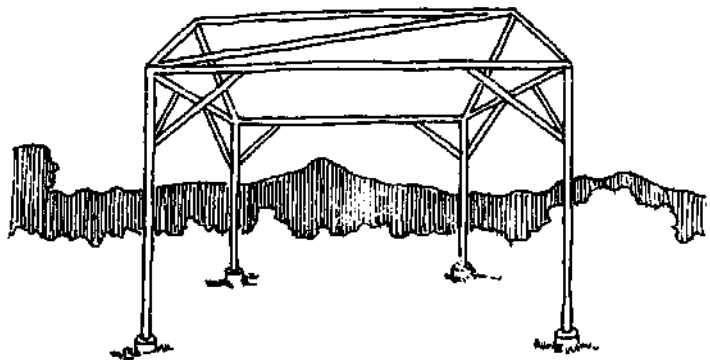

In this example the portion of the building to the left or to the right of plane ABCD may be made stable by Rule 1 and the other side made stable by application of Rule 4. It is not a stable arrangement as shown.

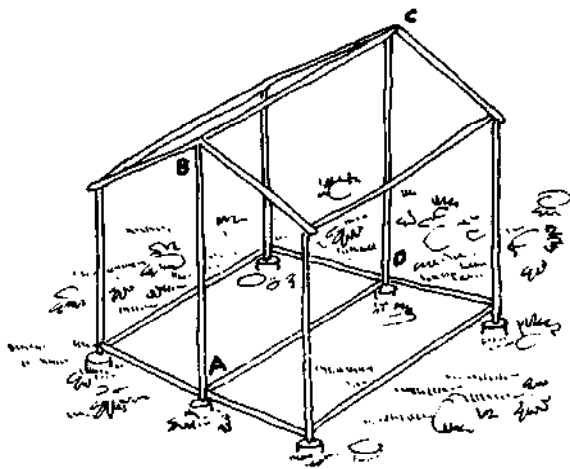

Unusual and Innovative Structures

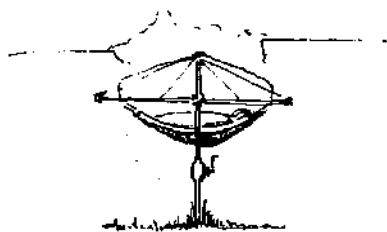

DOCUMENTATION

In some cases, homebuilders may propose to erect a dwelling over a lengthy period without a fully predicted plan. A guide letter to the Council for a proposal of this kind is included in Appendix 3.

The Council will require the submission of a minimum plan and outline specification. As ideas, site influences and available resources affect the building program, discuss progress with the building inspector. Variation plans and eventually a final plan will have to be submitted.

Some innovative buildings may be so complex that an opinion on structural adequacy may be difficult to obtain from the Council or a practising structural engineer. Under these circumstances, the owner-builder should apply to the Council for permission to test the structure after completion but prior to occupation.

Suitable tests for unusual timber structures are described at the end of the section on Timber Construction.

Models, photographs, research materials, etc. should be useful when seeking Council's assistance for these proposals. Homebuilders considering building structures of unusual geometry should familiarise themselves with the techniques of jointing and weatherproofing such buildings.

FERROCEMENT STRUCTURES

Ferrocement structures are usually constructed by plastering a sand/cement mortar onto a reinforcement framework of chicken wire combined with steel bars or welded steel mesh.

The reinforcement framework may be supported by a permanent wooden framework, which is either fully or partially loadbearing, or by removable temporary supports, or it may be freestanding. Prospective builders should take care with the waterproofing of ferrocement. Factors that improve impermeability are:

- Rich mortar mix – boatbuilders typically use sand/cement ratios of less than 2:1.
- Tightly packed reinforcement mesh preventing the mortar from cracking due to the action of curing, temperature changes and load carrying.
- Mortar waterproofing additives.
- Curing of ferrocement in a humid atmosphere which minimises cracking during curing.
- Surface treatments.

In the case of dome-shaped structures totally constructed from ferrocement and tied down to reinforced concrete footings, the following guidelines apply:

1) The weight of the whole structure is usually sufficient to prevent wind uplift. If the builder can show that the weight of the structure, including the footings, divided by the floor area is greater than 0.5 kPa (10 lb/sq. ft.) then wind uplift may be considered to be prevented.

2) If the structure is totally plastered in one day's work on the freestanding reinforcement without temporary supports, then the reinforcement alone is carrying the weight of the wet mortar which, in any shell over 12 mm thick, is greater than the design load for untrafficable roofs, i.e. 0.25 kPa, and the final strength of the cured ferrocement is significantly greater than the reinforcement strength. Ferrocement structures constructed in this way are therefore adequate for domestic shelters without further structural calculations or testing, except where subject to snow loading. In the case of snow loading a load test may be used. Note that the critical cases are:

- a) loaded over whole surface;
- b) loaded over half surface.

Connection of a Building to the Earth

The relationship of a building to the ground represents one of the more difficult areas for the homebuilder, in that there is often a degree of uncertainty as to the exact nature of subsoil conditions. In addition the penetration of termites from the ground into the timber structures requires further mechanical or chemical barriers. The chemical preservation of timber is outlined in Appendix 6, while a mechanical means of termite control (ant-capping) is dealt with in this section.

This section also provides tables for the selection of timber, concrete, and masonry pier footings for lightweight buildings, and strip footings of masonry and reinforced concrete. However, the owner-builder is advised to consult other references, such as the Notes on the Science of Building (see Appendix 10) for further guidance.

FOUNDATION MATERIAL

Foundations may consist of soft clay or loam, confined sand, medium or sandy clay, dry clay or dense sand, soft shale, weathered rock or medium shale, shale rock or solid rock (Ordinance 70, 32.3 (1)). All these materials have an allowable bearing pressure greater than 100 kilopascals (kPa). Adequacy of foundation material to support proposed structures can be assessed from local knowledge or testing. Foundations should not consist of excavated fill unless it is properly retained and compacted; where it is proposed to build over fill, footings should be deep enough to reach natural ground below.

EXCAVATIONS

Excavated ground should either be retained by a suitable retaining structure of stone, waterproofed mudblock, durable timber, etc., or allowed to fall in its natural angle of repose and replanted. Temporary deep excavations should be properly shored up where any danger of collapse exists. Provision should be made for drainage, under the soil and/or above ground (Ordinance 70, Part 31).

Areas prone to slip (which often can be identified by trees leaning downhill) should be avoided if possible, or building confined to lightweight structures, with the minimum amount of excavation back into the slope.

TYPES OF FOOTINGS

For domestic construction, footings are generally of three types: continuous, strip and pier footings.

CONTINUOUS is where the floor is a concrete slab-on-ground, with thickening and reinforcing in areas which carry the extra load of the walls and roof.

STRIP FOOTINGS run under the walls of a building and often carry some of the weight of suspended floors. These are used for heavy construction such as masonry and pise.

In single-storey construction, *earth or brick strip footings* laid under 75 to 110 mm masonry walls should have two courses of work at least 300 mm wide. Under 190 to 300 mm thick walls, use two courses at least 450 mm wide.

In two-storey construction, add a further course 150 mm wider than the above dimensions underneath the single-storey footings.

Earth blocks should be used as footings only if made waterproof by the addition of a stabiliser such as cement or slow-breaking anionic bituminous emulsion. The graph shows the percentage of additives needed for earths with clay contents indicated:

Stone strip footings should consist of all through stones 600 mm wide x 250 mm thick under stone walling or earth block walls 190 mm to 300 mm thick, and 450 mm wide x 250 mm thick under earth block walls between 75 mm and 110 mm thick.

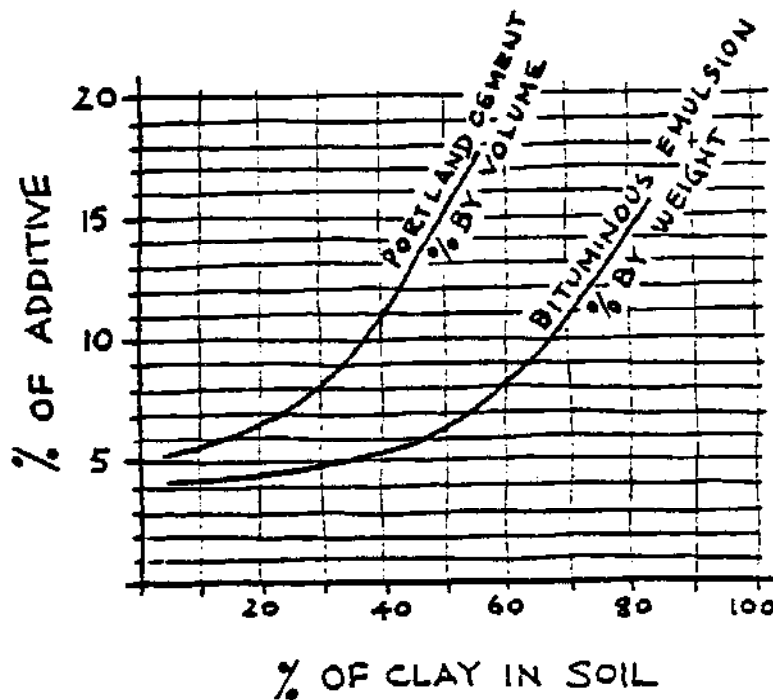

Reinforced concrete strip footings should be of 4:2:1 mix concrete to the dimensions shown in the table below:

CROSS-SECTIONAL DIMENSIONS OF REINFORCED CONCRETE STRIP FOOTINGS

Construction of Wall	Nominal Thickness of wall to be supported — not more than:	Size of concrete (width x depth)	
		For stable soil foundations such as retained sand or gravel	Other foundations not subject to significant movement or loss of stability with climatic changes
	(mm)	(mm)	(mm)
Earth block and stone single-storey with wall height not exceeding 4200 mm excluding any gable	300	450 x 250	450 x 300
Earth block and stone two storeys with — External wall height not exceeding 7200 mm excluding any gable	300	550 x 250	550 x 300
Internal wall height not exceeding 3600 mm	110	300 x 250	300 x 300

REINFORCEMENT FOR STRIP FOOTINGS

Width of strip footing	Minimum number of main wires per layer using F 8TM or F 818 fabric	Minimum number of 10 mm diameter bars per layer	Minimum number of 12 mm diameter bars per layer
(mm)			
230	2	2	2
300	3	3	2
380	3	3	2
450	4	4	3
550	5	5	3

NOTE: In the case of known highly swelling soils or other unstable soils special precautions may have to be taken in the design and construction of concrete footings.

(Based on 'Acceptable Standards of Construction,' Registry of Co-Operative Societies)

Footings should give full support to walls and engaged piers and overlap not less than 600 mm where steps occur. Steel reinforcement should be equally distributed in two layers with a minimum cover of 60 mm all round, and be laid continuously with 450 mm laps at all joints, and full width overlaps at all corners. All overlaps should be tied up with steel wire.

PIER FOOTINGS. There are many varieties of pier footings to cope with a range of soil conditions, and they may be built of masonry, concrete or timber stumps. They generally carry lightweight structures and suspended floors.

Masonry piers are generally designed on the basis of height to thickness (known as the slenderness ratio), as the compression strength and bearing area are usually adequate for domestic construction. Earth blocks should be waterproofed as for earth strip footings, and the following sizes should be used:

- (a) Earth block or brick bearer piers up to 1800 mm high — two courses of work at least 450 mm square under earth block piers 300 x 300 mm and concrete block or brick piers at least 200 x 200 mm. If piers exceed 1800 mm in height a course at least 50 mm wide all round should be added to the lower portion.
- (b) Stone bearer piers up to 1800 mm high — 450 x 450 x 250 mm at the base with piers of minimum 250 x

250 mm increased to 300 x 300 mm for piers over 1800 mm.

(c) Engaged piers in earth block — at least 150 x 300 mm.

(d) Engaged piers in brick or stone at least 200 x 90 mm.

Timber Piers or stumps require more comprehensive design consideration, and the use of a timber or masonry sole plate in the smaller section stumps, to spread loads over a wider area.

The footing type (A, B, C — see table) to be used is determined from the spacing between piers in the direction of bearers, and the spacing between bearers. The footing type can then be used to select timber stump and soleplate sizes (from the Light Timber Framing Code AS1684 — 1975) and unreinforced concrete pad footings.

SPACING OF STUMPS ALONG DIRECTION OF BEARERS

Bearer spacing (metres)	Under loadbearing walls Supporting sheet roofing (metres)	Not under loadbearing wall (metres)
	1.8	up to 1.6 Type A 1.7 to 3.2 Type B 3.3 to 4.2 Type C
2.4	up to 1.5 Type A 1.6 to 2.9 Type B 3.0 to 3.8 Type C	up to 1.7 Type A 1.8 to 3.4 Type B 3.5 to 4.3 Type C
3.0	up to 1.3 Type A 1.4 to 2.7 Type B 2.8 to 3.5 Type C	up to 1.4 Type A 1.5 to 2.9 Type B 3.0 to 3.7 Type C

FOOTINGS TO TIMBER BUILDING STUMPS

Type	Minimum bearing area (square metres)	Minimum stump section (mm)	Recommended sizes for timber soleplates:		
			Length (mm)	Width (mm)	Thickness (mm)
A	0.045	90 x 90 or 110 round	450	100	75 or over
			300	150	38 or over
			250	200	50 or over
		120 x 120 or 140 round	300	150	38 or over
			250	200	38 or over
			300	150	38 or over
		140 x 140 or 160 round	300	150	38 or over
			225	200	38 or over
			200	250	50 or over
190 x 190 or 210 round	Timber soleplate not recommended				
B	0.090	90 x 90 or 110 round	450	200	50 or over
			380	250	75 or over
			600	150	50 or over
		140 x 140 or 160 round	380	250	50 or over
			300	300	75 or over
		190 x 190 or 215 round	Timber soleplate not recommended		
C	0.120	90 x 90 or 110 round	480	250	75 or over
			600	200	75 or over
		120 x 120 or 140 round	600	200	75 or over
			Timber soleplate not recommended		

Recommended sizes for unreinforced concrete footings (mm)

Type A — 230 x 230 x 100 deep or 250 dia. x 100 deep

Type B — 300 x 300 x 150 deep or 350 dia. x 150 deep

Type C — 350 x 350 x 200 deep or 400 dia. x 200 deep

ANT CAPPING

Galvanised ant caps should be provided on all bearer piers, engaged piers and dwarf walls in masonry construction, and on all timber stumps. Care should be taken in detailing to avoid fixing bearers through the ant caps (see diagram). All avenues of connection to the ground, such as drainage pipes, should also be shielded.

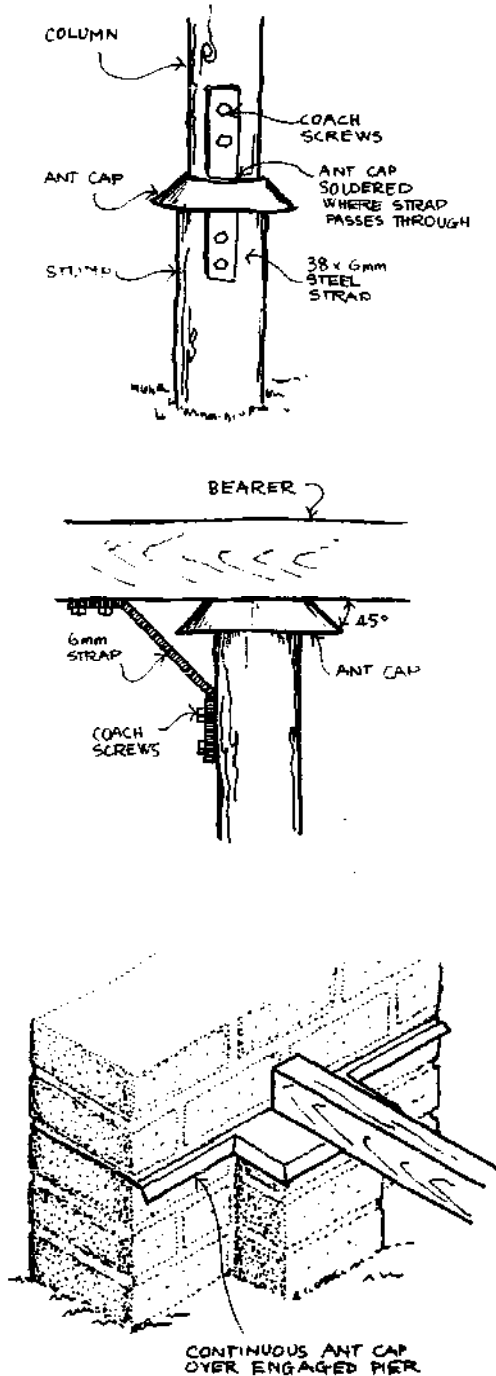

Sufficient space should be left between the ground and bearers of a suspended timber floor to provide crawl space for inspection and maintenance of sub-floor timbers. This space should be adequately cross-ventilated to prevent the damp conditions conducive to fungal decay.

Massive Construction

EARTH CONSTRUCTION

There are several different techniques of earth construction:

- Adobe — mudbricks
- Pressed earth blocks (e.g. Cinva Ram)
- Pise blocks
- Pise — monolithic walling of rammed earth.

The first three are considered together as earth masonry. Each construction technique has a special character, with its own advantages and disadvantages. The homebuilder is advised to consult the wide range of literature available (see References) and check with any local precedent or practice when deciding on earth construction techniques.

EARTH MASONRY

External walls of earth masonry should be a single leaf (no cavity) with a recommended minimum thickness of 300 mm, which allows for optimum structural and thermal performance. Internal non-loadbearing walls may be constructed of "blocks on edge" having a minimum thickness of 125 mm. For stability, all earth masonry walls should include engaged piers or crosswalls at 2400 mm centres for work up to 1800 mm high. Freestanding sections of earth walling should be supported by engaged piers at each end. Earth masonry used in the construction of footings or around wet areas in the building should be stabilised with cement or slow breaking anionic bitumen emulsion added to the mix.

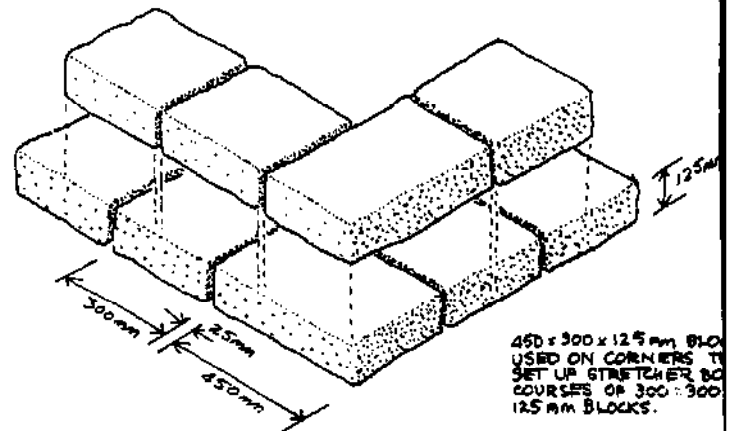

Care should be taken to allow for adequate overhangs or verandahs on earth walls in positions exposed to wind-driven rain. If walling is found to be excessively erodable, a surface treatment may be used.

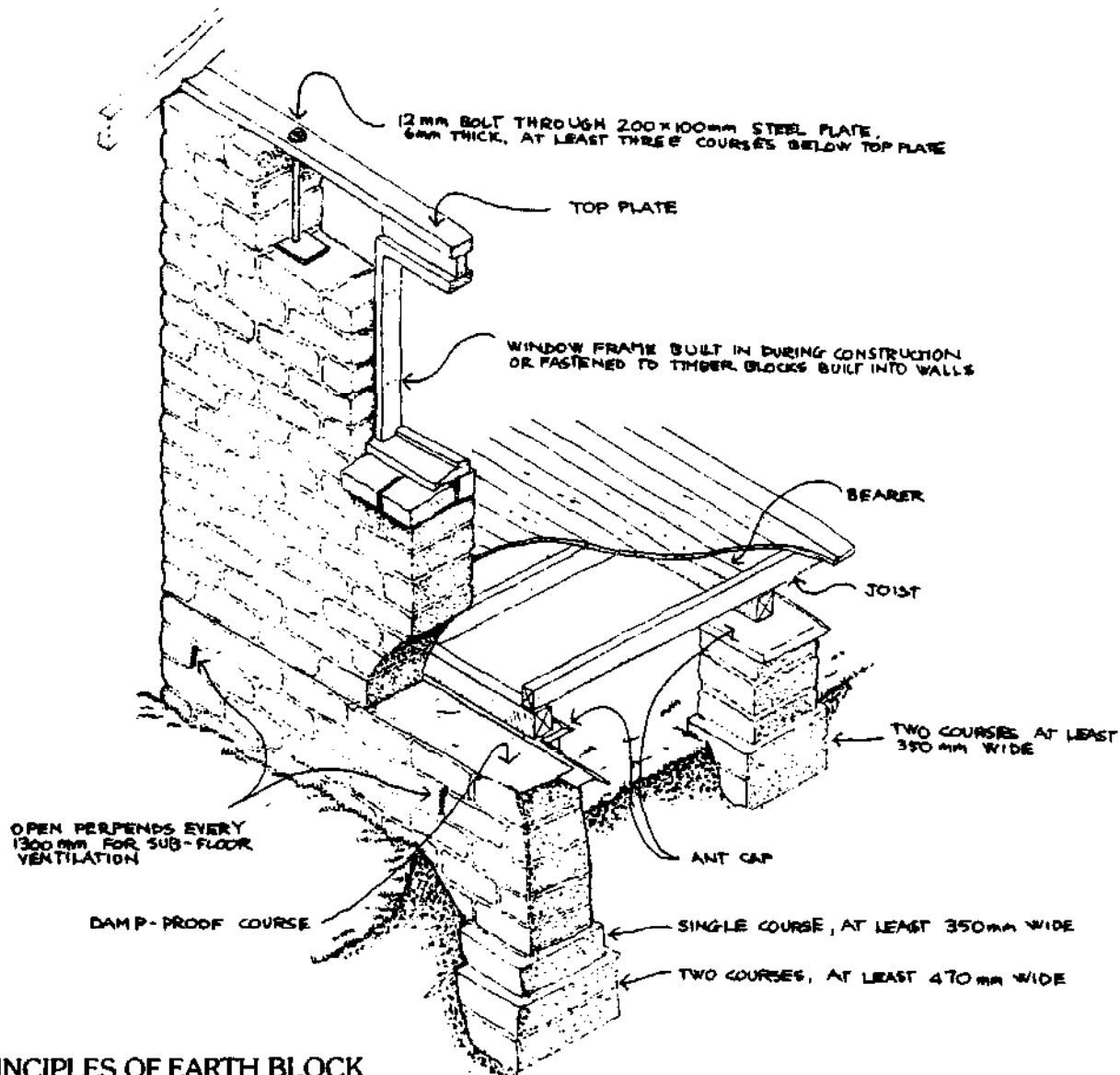

PRINCIPLES OF EARTH BLOCK CONSTRUCTION

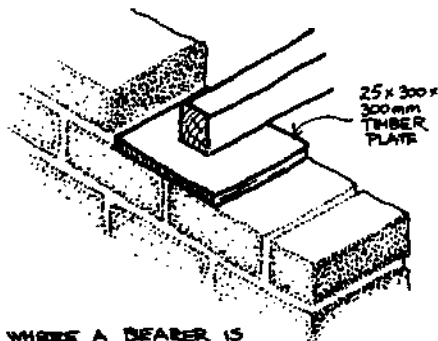

WHERE A BEARER IS SUPPORTED BY AN EARTH WALL, THE LOAD SHOULD BE SPREAD BY A TIMBER OR METAL PLATE

Suitable finishes for earth walling in conditions of high exposure to weathering (including bathroom and laundry walls) are listed in order of excellence (i.e. high to low impermeability, and low to high maintenance).

- Solpah oil (the most resistant and durable finish)
- Bituminous paint
- Cement render
- Silicone sealer
- Whitewash (latex based)
- Linseed oil
- Waterproofing additive to concrete (used as surface treatment)
- Cowdung and mud render
- Mud render
- Latex-based paint
- Whitewash or limewash
- Wallpaper size
- Mud bagging

PRINCIPLES OF PISE CONSTRUCTION

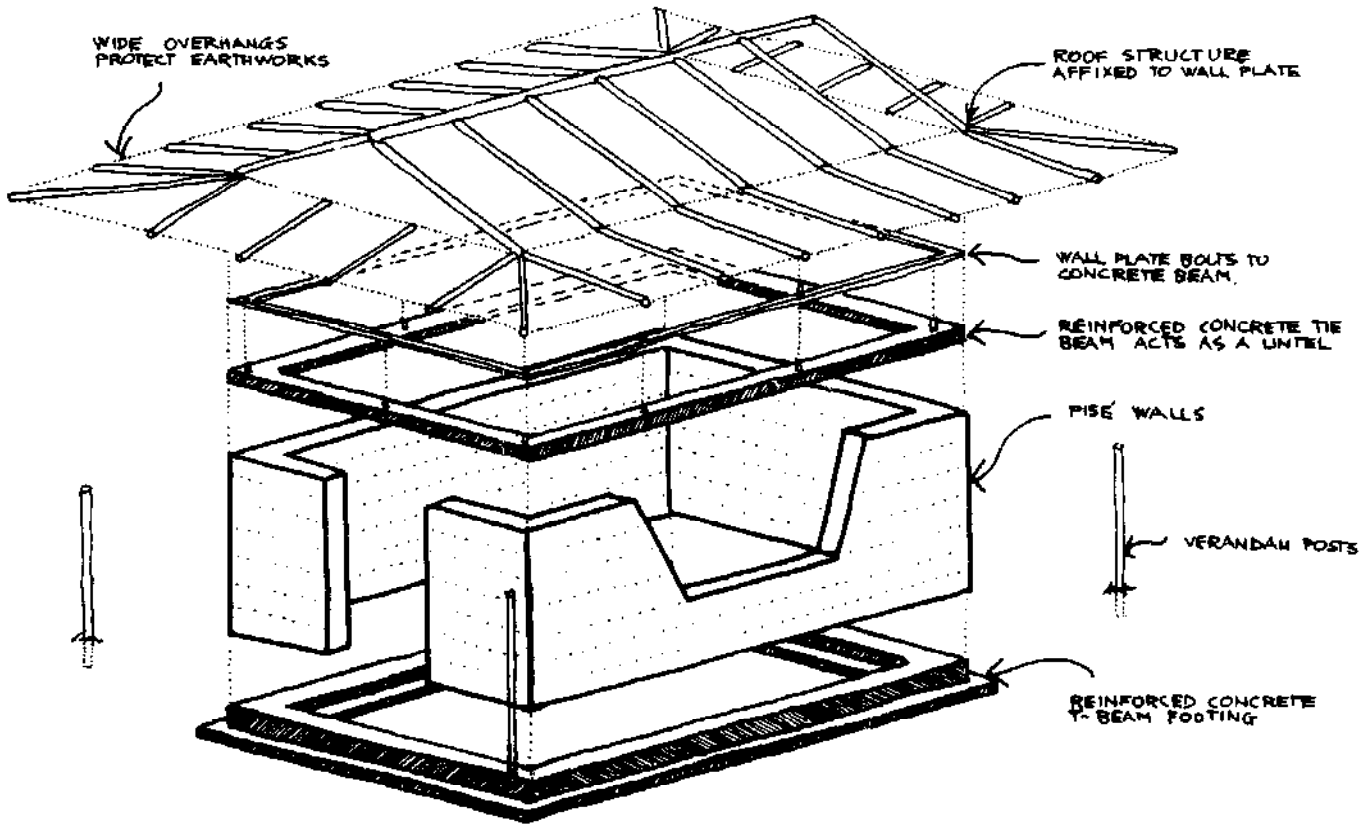

STONE MASONRY

Stone masonry should be laid with each stone distributing its weight evenly on those below it on a horizontal bedding plane and with careful attention to the avoidance of continuous vertical joints.¹

In single storey buildings external and load bearing walls of stone masonry should be laid in mortar with joints having a nominal thickness between 15 mm and 30 mm in walls not less than 200 mm thick. In taller structures stone-walling is required to be thickened at its base or through its entire height.

Dry stone-walling should be constructed with even greater attention to good practice and should conform in height and thickness to the following table. (Thicknesses refer to freestanding walls. Where crosswalls are used, reductions may be permitted.)

Height (m)	1.0	1.2	1.5	1.8	2.1	2.4	2.7	3.0
Thickness (mm)	340	370	410	450	490	520	550	580

NOTE: These walls require substantial foundations as loads are quite considerable.

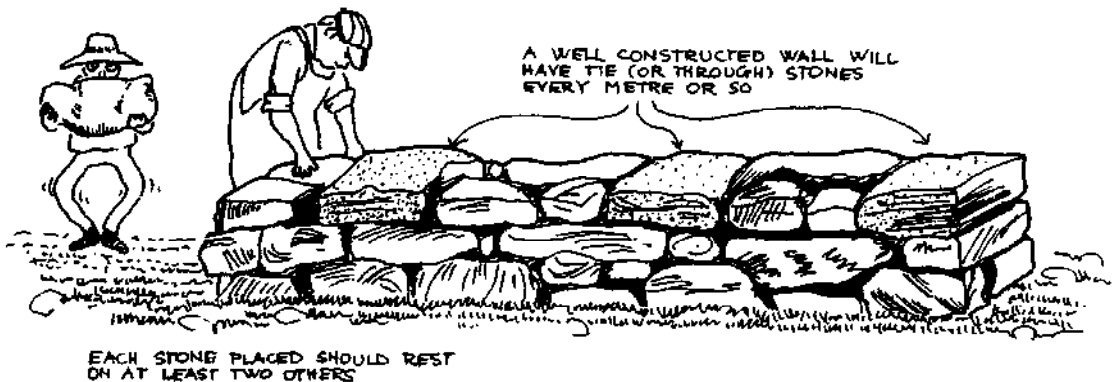

PRINCIPLES OF STONE WALL CONSTRUCTION

BOTTLE MASONRY

Glass bottles may be used as a translucent, non-loadbearing infill wall. Bottles should be clean, and laid with the necks pointing outwards, bedded in a 5:1 sand/cement mix. A minimum of mortar should be used, and excess should be cleaned off the bases as they are laid. Wire reinforcement is used every six courses to tie the wall into surrounding load-bearing structures.

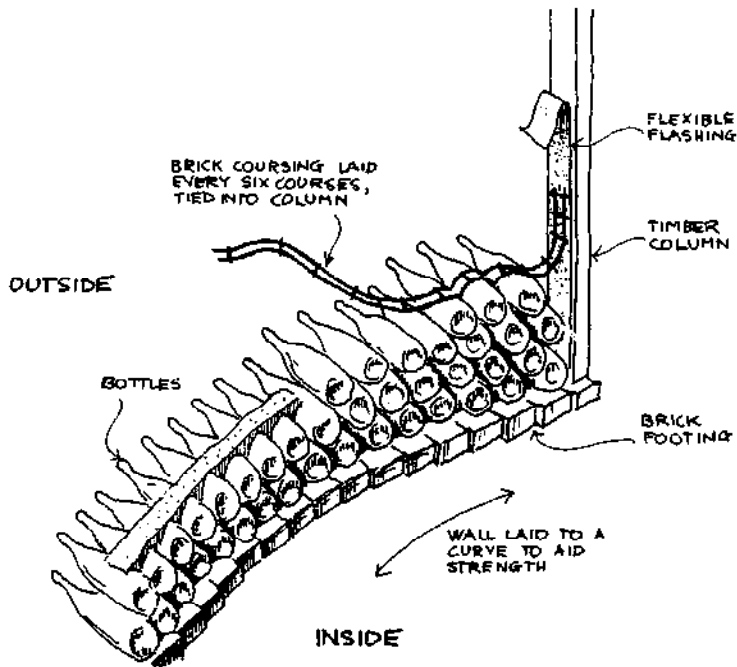

PRINCIPLES OF BOTTLE WALL CONSTRUCTION

MORTARS IN MASONRY CONSTRUCTION

The following mortars may be used:

- 1) Mud mortar for earth block construction consisting of earth mixed with water, free from organic matter and sieved to remove stones, can be used above damp-proof course level. For work below damp proof course level add one part Portland cement to nine parts earth. Earth used in mortar should have a clay content between 25 per cent and 50 per cent; sand may be added to reduce clay content. Mortar joints in earth masonry should have a minimum thickness of 25 mm.
- 2) Cement mortar for stone and brick masonry below damp proof course level should consist of one part cement to six parts sand. Above this level use a mix of two parts cement to nine parts sand.
- 3) Compo mortar for stone and brick masonry: add one part hydrated lime to the cement mortar mixtures above.

DAMP-PROOFING OF MASONRY WALLS

Damp-proofing of lead, bituminous coated non-ferrous metals, polythene or other suitable material (refer to Ordinance 70, Specification 5, part 47,10(a)) should be built into all earth and stone masonry at a height not less than 150 mm above the finished ground level. Sheet materials should be lapped 100 mm at joints.

To earth or stone masonry walls surrounding solid floors, bathrooms, shower rooms, laundries, etc., an additional damp proof course should be built in one course above floor level and be dressed down to cover the edges of the damp proof membrane under the solid floor.

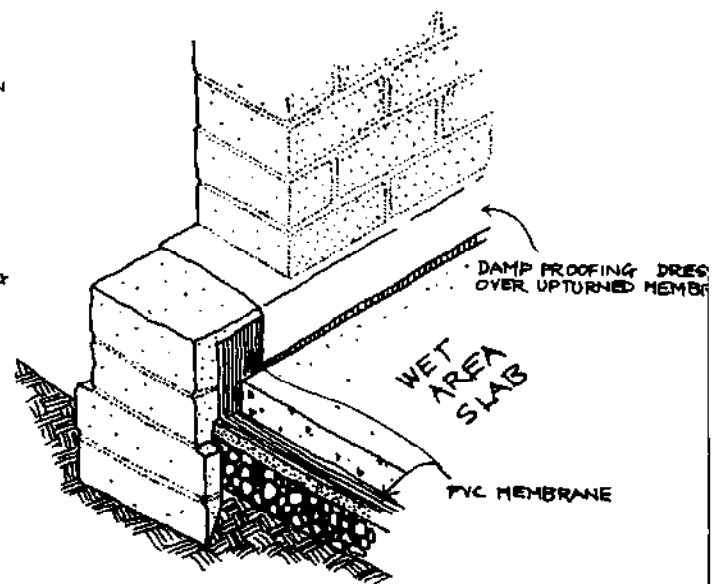

DAMP PROOFING OF WET-AREA FLOORS

Timber Construction

This section deals mainly with round hardwood pole construction with some attention given to sawn timber construction for those situations where round poles are inappropriate, e.g. floor joists.

Conventional timber construction is adequately covered in other publications; sawn timber member sizes can be found in AS 1684 "Light Timber Framing Code" which has supplements for specific timber strength groups.¹

SELECTION OF TIMBER

The selection of timber species will be dependent on local availability and the qualities required for different components of the structure, e.g. stumps will need to be more durable than, say, rafters. A list of building timbers and their properties is contained in Appendix 5 (for species identification see Hall et al., 1970).

An important consideration is that of decay and insect attack arising from contact between timber structural members and the ground. While it is possible to achieve satisfactory performance in ground contact with highly durable and termite resistant timbers, this may not represent an efficient use of resources where pole-in-ground construction is used, as high durability is unnecessary in the upper, more protected parts of the structure. A wide range of less durable non-resistant timbers may perform equally well for these parts of the structure provided they are suitably detailed to prevent termite penetration.

In areas where no durable timbers are available and chemical preservation is felt to be undesirable, then slab on ground construction or the use of masonry footings and piers may be the most appropriate solution.

PROTECTION OF TIMBER

The three main agents of timber deterioration are:

1) Rot and decay due to fungal attack in the sapwood of all species and the heartwood of certain timbers. This form of attack is promoted by warm, damp, dark and/or poorly ventilated spaces.

2) Insect attack which is most commonly due to the Lyctus beetle (powder post beetle) and termites. The Lyctus beetle attacks sapwood of some hardwoods and can therefore reduce the strength of a structural member containing sapwood. Lyctus attack commences immediately the tree is felled. Generally an infestation is complete in 12 to 18 months and does not recur since consumption of the food component (starch) by the larvae is completed.

Termites attack both sapwood and heartwood of non-resistant species of timber from underground nests. Termites must maintain contact with the nest and do so by building earth galleries, which can be easily identified, across metal barriers such as ant caps.

3) The action of water and sunlight on exposed end-grain and sapwood.

The protection of timber can be approached in two ways:

Chemical preservation. This involves the treatment of timber members prior to construction, and soil poisoning. See Appendix 6.

1. A more convenient and cheaper reference is produced by the N.S.W. Timber Industry Organizations.

Mechanical protection. This involves the use of ant caps for the prevention of termite attack, durable footing materials, and replaceable timber stumps. See Ant capping.

Note: Unless the home builder is prepared to use preservative treatments and to poison the soil around footings, then the use of pole-in-ground construction is not recommended for habitable buildings.

SAWN TIMBER CONSTRUCTION

Homebuilders using predominantly round pole construction are advised to use sawn hardwood floor joists to avoid problems when fixing flooring. Sizes may be selected from the following table.

SAWN HARDWOOD FLOOR JOISTS

SPACING	SPAN (m)	JOISTS (mm)
450 mm	1.5	75 x 38
for softwood flooring	1.8	100 x 38
	2.1	100 x 50
OR		
600 mm for hardwood flooring	2.4	125 x 38
	2.7	125 x 50
	3.0	150 x 50

Where two sections of sawn timber are to be used together to provide the strength of a single section, the following rules apply:

RIGHT

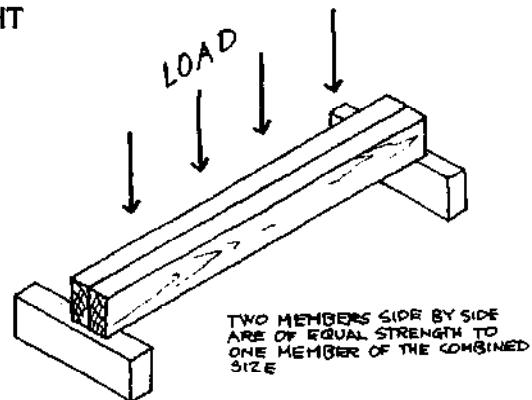

WRONG

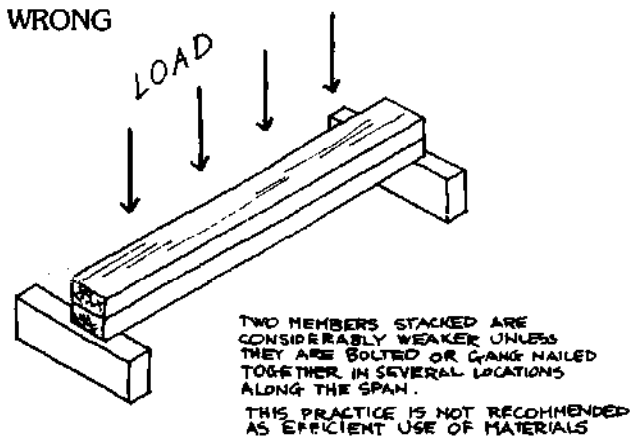

USE OF COMPOSITE SECTIONS

DIRECT REPLACEMENT OF SAWN TIMBERS BY ROUND POLES
(This table does not cover the replacement of round poles by rectangular sections)

Rectangular section	75	75	75	100	100	100	100	125	125
	x	x	x	x	x	x	x	x	x
	38	50	75	38	50	75	100	38	50
Diameter of round pole	75	80	85	90	95	110	120	105	115
Rectangular section	125	150	150	150	175	175	200	200	
	x	x	x	x	x	x	x	x	
	75	38	50	75	50	75	50	75	
Diameter of round pole	125	120	130	145	145	165	165	180	

ROUND POLE CONSTRUCTION

The member sizes given in this section are intended to ensure a safe, rigid structure erected in areas exposed to wind forces. In many instances, such as in well-wooded areas, or where protective landforms exist or reliable windbreaks have been planted, it may be possible to show that smaller members are adequate, but detailed analysis of these cases is beyond the scope of this handbook.

IMPORTANT NOTE: The diameters in these tables apply to species with Lyctus-resistant sapwood, or with sapwood adequately treated in accordance with Appendix 6 of this document. If untreated Lyctus-susceptible sapwood is used the diameters in these tables should refer to the heartwood only.

If a round pole is used as a direct replacement for a rectangular sawn section in traditional construction, its diameter at its midlength should be as given in the following table, with special attention to the important note above.

A) UNBRACED POLE-IN-GROUND CONSTRUCTION

Pole butt diameters given in this table apply to poles embedded in the ground or in concrete, which are required to provide sufficient building stability without further bracing. The diameters apply to the heartwood of durable species, or to the overall diameter of poles preservative-treated in accordance with Appendix 6. The sapwood of untreated poles should be removed to 300 mm above ground as it decays quickly allowing the pole to loosen. Durable species and expected life-in-ground are indicated in Appendix 5.

Notes

1) If species of durability class 3 are to be used without preservative treatment the diameters of heartwood should be increased 25 per cent to allow for decay during the building's expected useful life.

2) Poles in this type of construction should not be notched at floor level.

UNBRACED POLE-IN-GROUND CONSTRUCTION

HEIGHT (m)	POLE BUTT DIAMETERS (mm) SPACING (m)	POLE BUTT DIAMETERS (mm)				EMBEDMENT			POLE BUTT DIAMETER FOR CASE OF NO WALLS (e.g. verandahs)
		F11	F14	F17	F22	Soft soil	Hard soil	Concrete	
3.00	2.40	180	165	155	145				
	3.00	190	175	165	155				
	3.60	205	190	175	165	1300	900	600	145
	4.20	215	195	185	170				
	4.80	220	205	195	180				
3.60	2.40	200	185	175	160				
	3.00	215	200	190	175				
	3.60	230	210	200	185	1400	1000	700	160
	4.20	240	220	210	195				
	4.80	250	230	220	200				
4.20	2.40	220	205	195	180				
	3.00	240	220	205	190				
	3.60	250	235	220	205	1500	1100	700	180
	4.20	265	245	230	215				
	4.80	270	255	240	220				
4.30	2.40	240	225	210	195				
	3.00	260	240	225	210				
	3.60	275	255	240	220	1600	1200	800	195
	4.20	290	270	250	230				
	4.80	300	280	265	240				
5.40	2.40	260	240	225	210				
	3.00	280	260	245	225				
	3.60	295	275	260	240	1700	1300	900	210
	4.20	310	290	270	250				
	4.80	325	300	285	260				

B) POLES USED AS COLUMNS IN FULLY-BRACED CONSTRUCTION

Where the building faces are braced by full-length diagonal bracing, as in diagram below for example, the vertical pole diameters may be selected from the following table. Sizes for poles used as beams in this structural system should be selected from the tables for floor bearers, lintel beams or rafters as appropriate.

COLUMNS IN FULLY BRACED CONSTRUCTION

HEIGHT (m)	SPACING (m)	POLE DIAMETERS AT MIDLENGTH (mm)			
		F11	F14	F17	F22
3.0	2.4	115	105	100	95
	3.0	125	115	105	100
	3.6	130	120	115	105
	4.2	135	125	120	110
3.6	4.8	140	130	125	115
	2.4	130	120	110	105
	3.0	140	130	120	110
	3.6	145	135	130	120
4.2	4.2	155	140	135	125
	4.8	160	150	140	130
	2.4	140	130	125	115
	3.0	150	140	135	125
4.8	3.6	160	150	140	130
	4.2	170	155	150	135
	4.8	175	165	155	140
	2.4	155	145	135	125
5.4	3.0	165	155	145	135
	3.6	180	165	155	145
	4.2	190	175	165	155
	4.8	200	185	175	160
	4.8	210	190	180	165

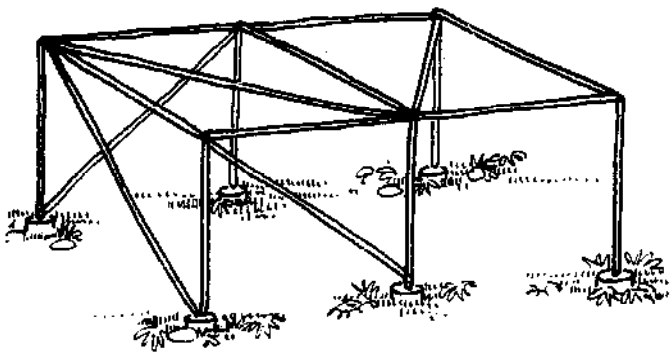

FULLY BRACED COLUMNS

C) POLES USED AS COLUMNS IN KNEE-BRACED CONSTRUCTION

Storm damage evidence indicates that knee-braced construction is a very sturdy structural system. This form of construction is recommended, and detailed information on pole and bolt sizes is contained in Appendix 7.

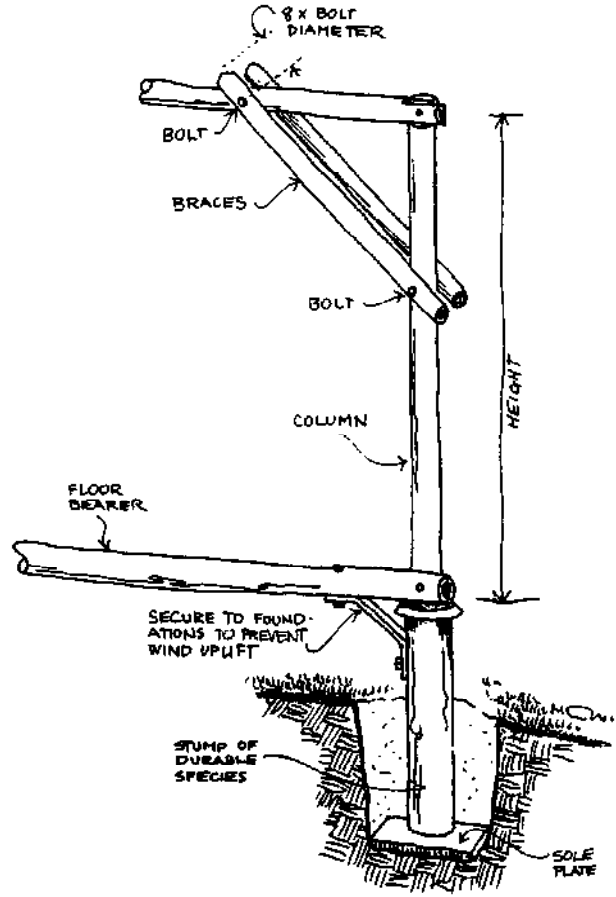

DETAILS FOR KNEE-BRACED FRAMES

D) POLES USED AS EAVES BEAMS AND RIDGE BEAMS

If an eaves beam or ridge beam is used in a structure supported at each end and not knee-braced as in section C, its size should be selected from the following table:

EAVES, BEAMS AND RIDGE BEAMS			
SPAN (m)	Pole diameters at midspan (mm)		
	Up to 3.0	Spacings (m) 3.6	4.2
3.0	125	135	145
3.6	145	155	165
4.2	160	170	180
4.8	175	190	200
5.4	195	205	215
6.0	210	220	230

E) POLES USED AS FLOOR BEARERS

The sizes for round poles used as floor bearers may be selected from the following table.

FLOOR BEARERS										
Spacing of Bearers	Bearer diameter at midspan									
	Spans (metres)									
	1.8	2.1	2.4	2.7	3.0	3.3	3.6	3.9	4.2	
1.8	105	115	125	135	150	160	170	185	200	
2.4	110	120	140	150	165	175	190	200	210	
3.0	120	130	150	155	175	185	200	215	225	

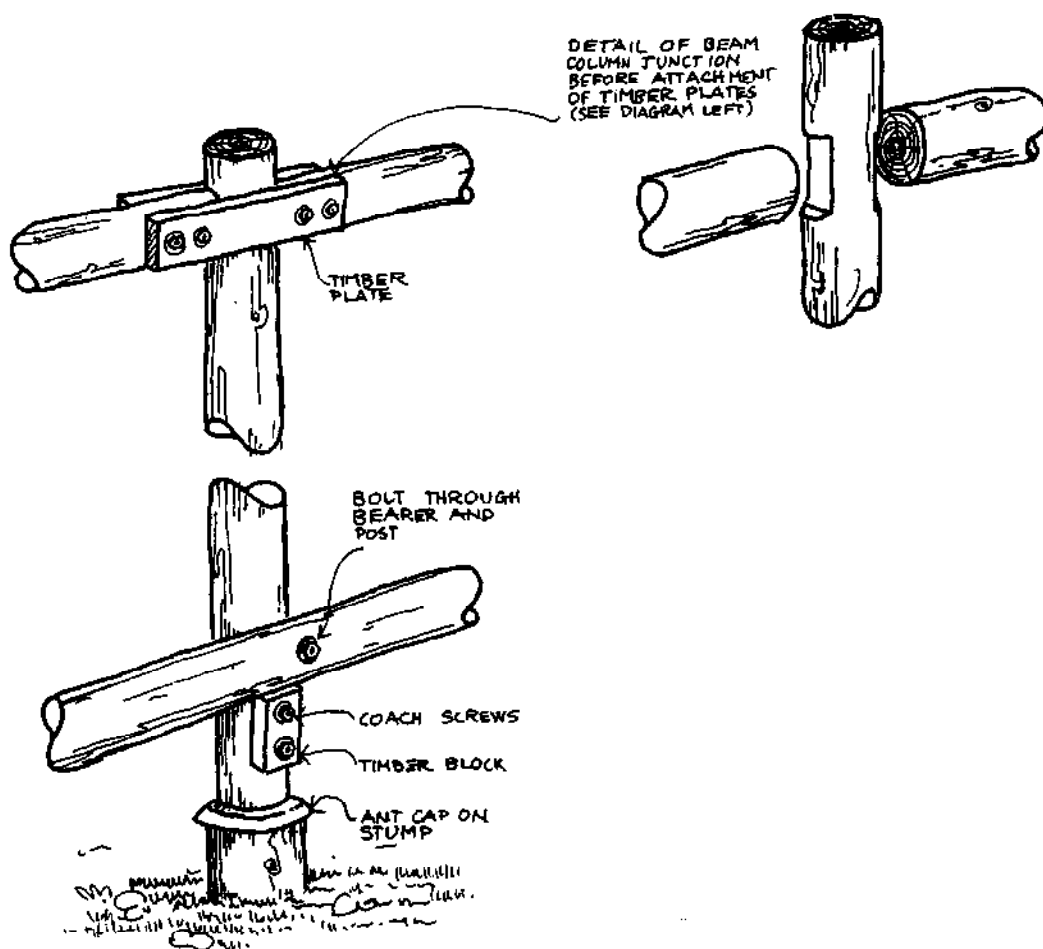

JOINT DETAILS FOR ROUND POLE BEARERS

F) POLES USED AS RAFTERS OR PURLINS

Pole diameters at midlength for use as rafters or purlins may be selected from the following table. These member sizes are suitable for sheet galvanised steel roofing with or without timber lining. Particular attention must be paid to ensure that the roof is held down against wind uplift. Strapping is recommended.

RAFTER & PURLIN SIZES

Spacing of rafters or purlins (mm)	Pole diameters at midspan (mm)					
	Spans (m)					
	Up to 2.1	2.4	3.0	3.6	4.2	4.8
450 or 600	75	80	90	105	120	130
900	75	85	95	110	125	135
1200	80	85	100	115	130	140
1500	80	90	105	120	135	150
1800	85	95	110	125	140	155
2100	90	95	115	130	145	160

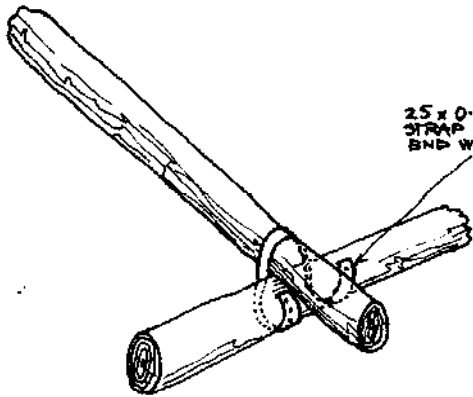

25 x 0.8mm GALVANIZED STRAP SECURED AT EACH END WITH THREE CLOUTS

FIXING OF RAFTERS TO BEAM

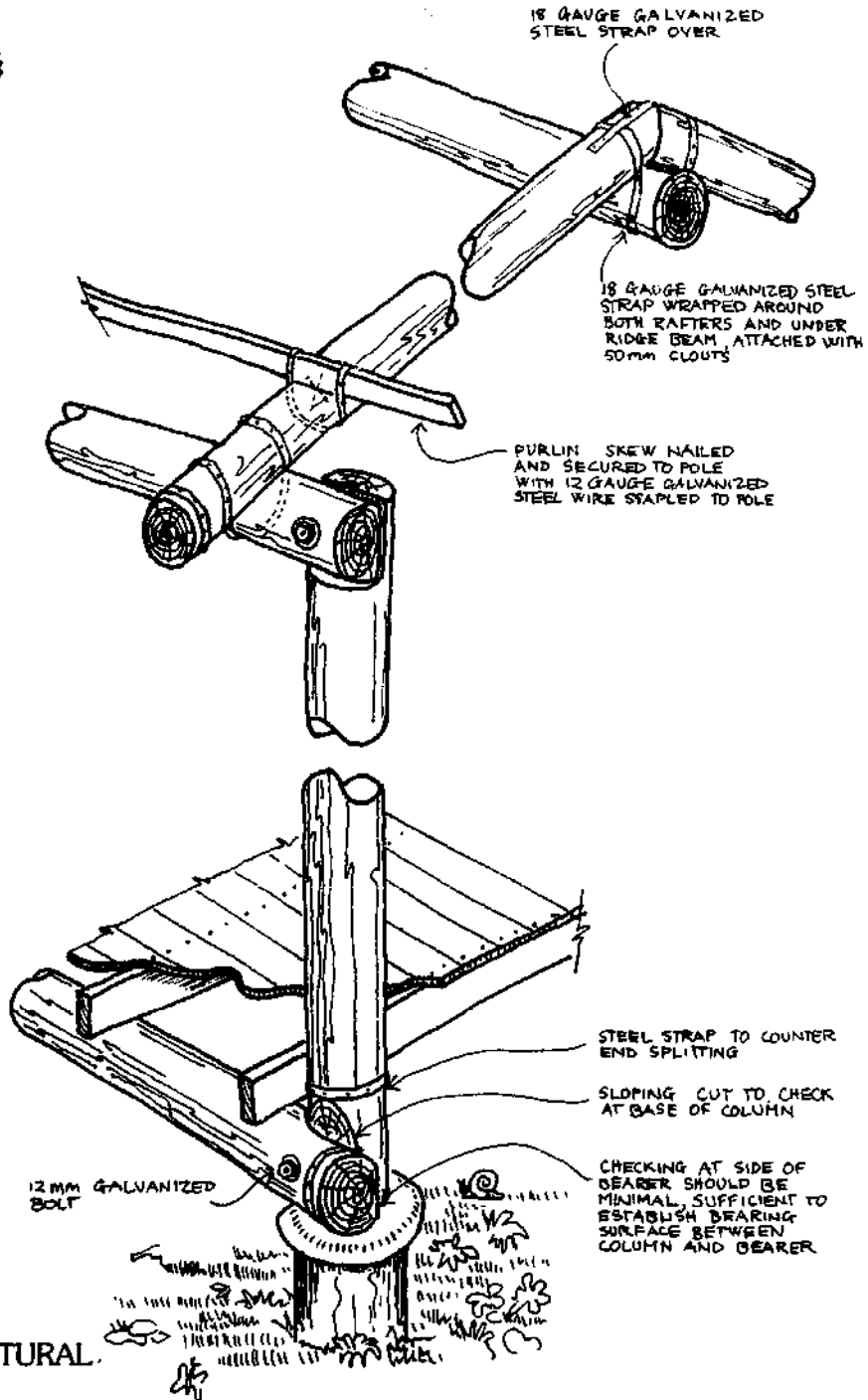

18 GAUGE GALVANIZED STEEL STRAP OVER

18 GAUGE GALVANIZED STEEL STRAP WRAPPED AROUND BOTH RAFTERS AND UNDER RIDGE BEAM, ATTACHED WITH 50mm CLOUTS

PURLIN SKEW NAILED AND SECURED TO POLE WITH 12 GAUGE GALVANIZED STEEL WIRE STAPLED TO POLE

STEEL STRAP TO COUNTER END SPLITTING

SLOPING CUT TO CHECK AT BASE OF COLUMN

CHECKING AT SIDE OF BEARER SHOULD BE MINIMAL, SUFFICIENT TO ESTABLISH BEARING SURFACE BETWEEN COLUMN AND BEARER

12mm GALVANIZED BOLT

ROUND POLES USED AS STRUCTURAL MEMBERS

G) POLES USED AS ROOFING BATTENS

Pole diameters at midlength for use as battens may be selected from the following table. These sizes are suitable for use with sheet roofing with or without timber lining. Particular attention must be paid to ensuring the battens are held down against wind uplift.

ROOFING BATTENS

spacing of battens (mm)	Batten diameter			
	Span of batten (rafter spacing)			
	450	600	900	1200
330 (for tiled roof)	30	30	35	45
450	30	30	35	45
600	30	35	35	45
900	35	35	40	45
1200	35	35	45	50

Strapping as shown for rafters is recommended.

If spans for battens are required to be greater than 1200 mm, use diameter given in table above for purlins.

TESTING FOR STRUCTURAL ADEQUACY OF UNUSUAL TIMBER STRUCTURES

There are three main types of loading which may be applied to a structure.

These load types are:

- The self weight of the building, called dead load
- Applied loads due to the use of the building, e.g. people and furniture, called live load
- Applied loads due to wind, called wind load

The load types can act in combination with each other. The following are the usual combinations:

- Dead load
- Dead load and live load
- Dead load and wind load
- Dead load and live load and wind load

Each of the load combinations is called a load case,

For most practical situations the following load cases are sufficient:

- 1) Dead load and live load on floors
- 2) Dead load and wind load on roof
- 3) Wind load on walls

Test load magnitudes for these cases are as follows.

DEAD LOAD PLUS LIVE LOAD ON FLOORS

The magnitude of the test loading is 5.5 kN/m^2 (five and a half kilonewtons per square metre). This load should be applied for 15 minutes. Note that it must be removed quickly after the 15 minutes have elapsed.

DEAD LOAD PLUS WIND LOAD ON ROOF

In most cases this loading combination gives a suction or lifting effect. It will be satisfactory to test it as with a downward load plus a careful check on joints holding down the roof to the building. In practically all cases it will be impossible to apply the load upwards — the upward load would lift most buildings.

The magnitude of the test loading is 1.75 kN/m^2 measured on horizontal surface. The load should be applied for 15 minutes.

Note that it must be removed quickly after the 15 minutes have elapsed.

WIND LOAD ON WALLS

The magnitude of the test loading is 2.5 kN/m^2 . The load should be applied for 15 minutes.

Note that it must be removed quickly after 15 minutes have elapsed.

COMMENTS

1) The test loadings involved are very large. When setting up a load test the ability to remove the load quickly from the structure (say within 30 minutes) should be considered. As a rough guide the material concrete weighs 24 kN/m^3 , water weighs 9.7 kN/m^3 , dry sand weighs 15 kN/m^3 , clay bricks weigh 18 kN/m^3 , clay weighs 15 kN/m^3 . (A 17 stone person weighs approximately 1 kN.) These weights are approximate.

2) Load cases 2 and 3 (Dead load and wind load on roof; Wind load on walls) occur together when the wind blows. However, it is very difficult to achieve this in a test.

3) In the case of roof tests the load of 1.75 kN/m^2 should be applied over the whole roof and then the structure tested again with 1.75 kN/m^2 applied to half the roof.

4) Under severe wind load conditions it is possible for light timber structures to be lifted off their supports. This problem is best avoided by ensuring that the roof structure is adequately anchored down through the walls to the ground.

ENVIRONMENT

Enclosure and Weather Proofing

This section concerns those principles of enclosure and weatherproofing, and the making of surfaces and openings such that the spaces of the building work in the manner appropriate to the lifestyle of the inhabitants.

It begins with the principles for keeping water from the inside of the building and then deals more fully with the elements of the building — the floors, walls, roofs and openings.

THE PRINCIPLE OF WATERSHEDDING

All materials and components used for the external surfaces of a building should stop rainwater and groundwater from penetrating to the inside.

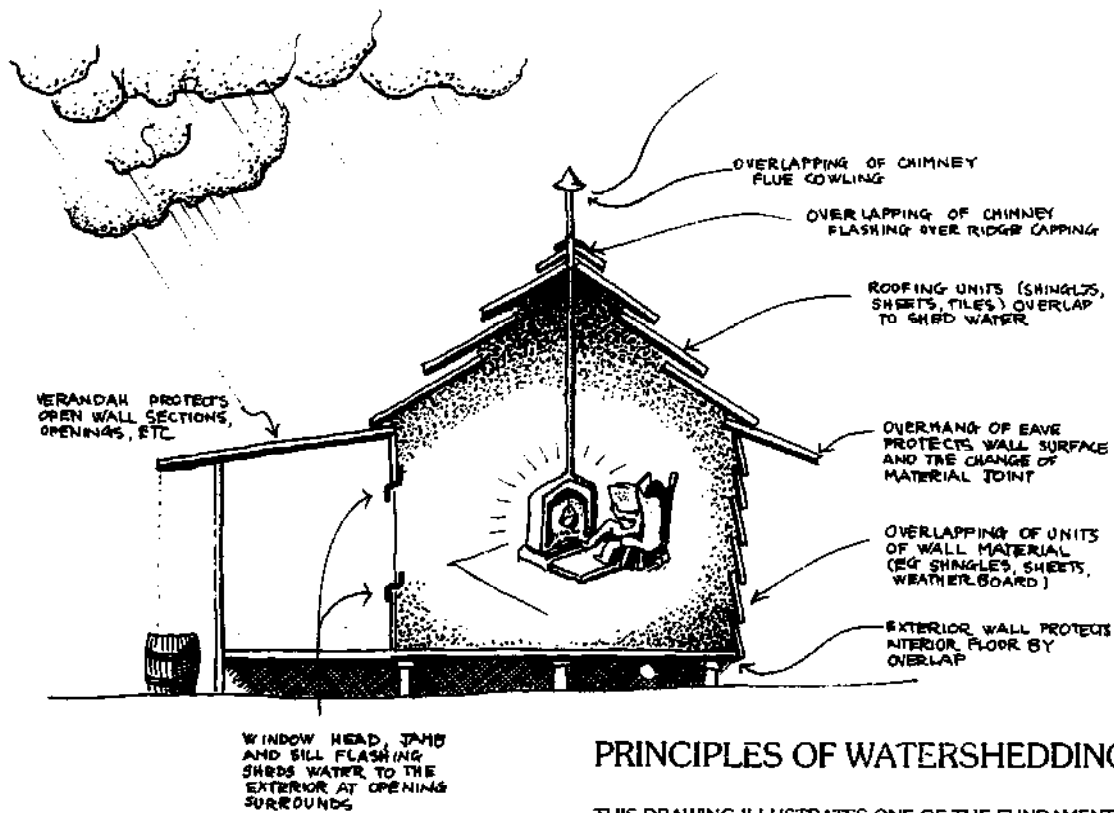

PRINCIPLES OF WATERSHEDDING

THIS DRAWING ILLUSTRATES ONE OF THE FUNDAMENTAL PRINCIPLES OF BUILDING — THE WAY THE STRUCTURE AND CLADDING CO-OPERATE WITH GRAVITY TO SHED RAINWATER FROM THE BUILDING AND KEEP THE INTERIOR DRY FOR HUMAN HABITATION

The diagram shows a building made of overlapping components. The principle still holds for masonry structure (e.g. the outer leaf of double skin brickwork “overlaps” the interior leaf) though in the case of single skin earth walls or concrete block, other means may be required to prevent the passage of water from outside to inside (e.g. protective eaves, waterproof renders, etc.).

Floors

There are two main types of floors — those built directly on the ground (such as concrete slab) and those built above the ground (such as suspended timber floors).

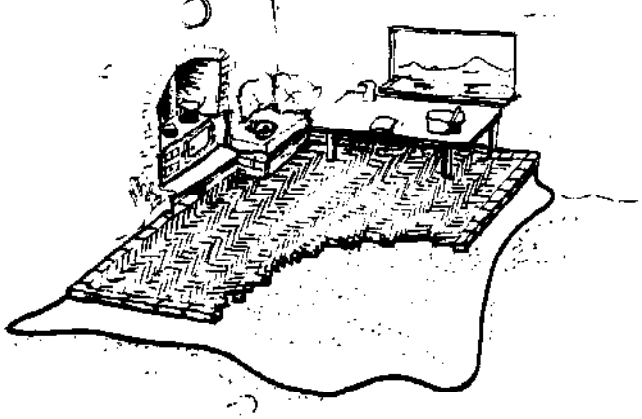

Timber block floor using “billets” — 75 to 125 mm diameter sections sawn into 150-200 mm lengths. These are set in a bed of sand over a damp-proof membrane on a further 25 mm of sand.

Sapwood should be removed and billets reshaped to fit together, e.g. hexagonally.



Monolithic earth floors, either poured adobe or pisé, should be laid 75-100 mm thick on 75-100 mm sand fill over a damp-proof membrane on a further 25-50 mm sand.

FLOORS ON THE GROUND

Because groundwater can exert pressure against those parts of a building in contact with the ground (particularly if they are below natural ground level), it should be collected and diverted away from the building using subsoil and/or above ground drainage. (See section on Drainage & Sanitary works). In addition, floors on the ground should be protected by provision of a damp-proof membrane from those materials listed.

- 1) Flexible materials — bitumen coated fabrics or polythene sheeting.
- 2) Semi-rigid types — asphalt, bituminous materials or tar, mixed with sand.
- 3) Rigid types — no-fines concrete.

The following are finishes and techniques suitable for floors on the ground.

Bricks or earth blocks (either adobe or pressed earth) laid on sand over a damp-proof membrane bedded on a further sand layer. Sand beds should be a minimum 25 mm thick.

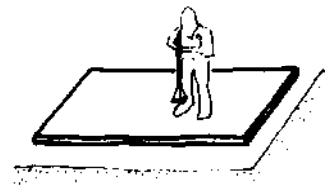
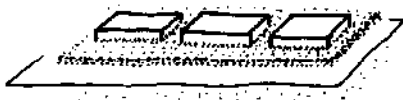

Reinforced concrete slab, laid over a damp-proof membrane on a 25 mm thick sand bed — refer to Experimental Building Station's *Notes on the Science of Building* No. 36 or consult the Building Inspector for sizing of reinforcing.

Notes

- 1) Stabilisers should be used in earth block or monolithic floors in areas subject to heavy traffic or dampness (such as kitchens, hallways, laundries). See *Earth Construction — an Advisory Document*
- 2) Cracks in earth floors should be filled with earth slurry, and finished with coats of linseed oil and turpentine mixture.

SUSPENDED FLOORS

Lightweight suspended floors are usually built up on the familiar timber structure of stumps (and ant caps), bearers and joists. See section on Sawn Timber Construction for sizing and spacing of this structure.

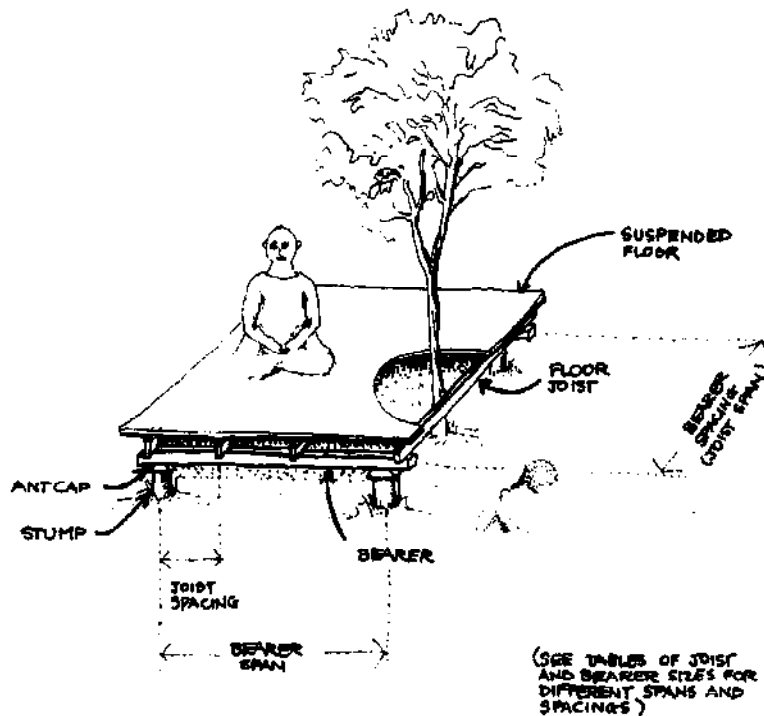

ELEMENTS OF A SUSPENDED FLOOR

The following finishes are suitable for suspended floors. New or recycled tongue and groove flooring. Support 19 mm softwood boards with joists at 450 mm centres, and 19 mm hardwood at 600 mm centres.



Processed timber sheeting ('pyneboard' or 'chipboard'). Support 19 mm sheet at 450 mm spacings, and 25 mm sheet at 600 mm spacings.



New or recycled plywood 19 mm thick. Support at 600 mm centres.



19 mm finished boards supported at 600 mm centres, fixed with 5-6 mm gaps are suitable for verandahs or bathroom floors if class 1 durability timbers are used (e.g. tallowwood).



19 mm or 25 mm boards dressed one side are suitable for internal and mezzanine floors.



SUBFLOOR VENTILATION

The space between the ground and the underside of a suspended floor should be thoroughly cross-ventilated by means of suitable air bricks set in the external walls to provide an unobstructed area of not less than 2100 square millimetres per 1000 mm run of wall.

In earth masonry and stone masonry, a hand-size hole should be provided every 1500 mm and where possible even larger openings left for ventilation and access to the subfloor area.

Subfloor ventilation openings should be screened to prevent entry of rats, snakes and other wildlife.

Walls

Walls are generally of two types, massive (e.g. masonry) and lightweight (e.g. timber clad frames). The construction and damp proofing of massive walls is detailed earlier.

In lightweight walls, materials and components may be joined to each other using any of the following methods so that they co-operate to make joints impervious to rainwater:

- Overlapping ends and/or sides
- using cover battens, sheet metal cover strips and cappings
- using flexible sheet material (sarking) behind the cladding, especially where it is required to protect the wall from wind-driven rain
- providing flashings of metal, bitumen coated fabric, metal coated with bitumen, or polythene, to the heads, sills and sides of openings.

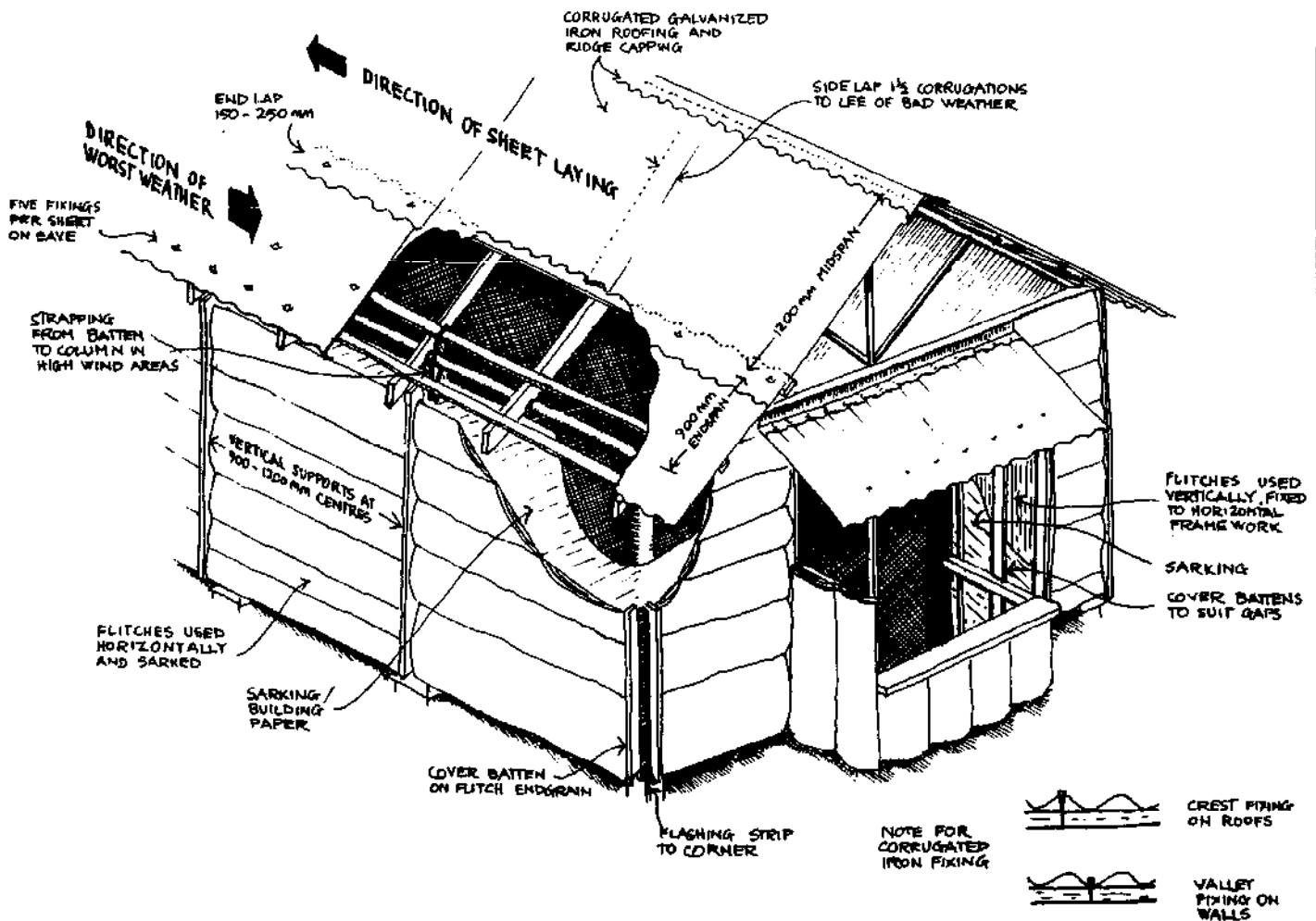

SOME CLADDING PRINCIPLES

THIS DRAWING ILLUSTRATES SOME GENERAL PRINCIPLES IN GALVANISED IRON ROOFING AND CLADDING USING FLITCHES. IT IS NOT MEANT TO DFFINE ALL POSSIBILITIES IN THEIR USE, BUT MERELY INDICATE SOME COMMON ARRANGEMENTS

Roofing

Roofs can provide protection for walls, windows, doors and open wall sections with wide projecting eaves and/or verandahs.

Roofing materials and components should protect the interior of the building by being joined to each other in such a way as to create an impervious joint. For example:

- end laps and/or side laps to sheet materials, tiles, shingles, etc. (see previous illustration)
- provision of flashings around all openings through roofs
- provision of sheet metal cover strips, mouldings and cappings at hips, ridges, edges, etc.
- provision of cowls or chimney trays to flues and chimneys
- provision of a damp proof membrane in the case of sod roofs
- provision of eaves gutters to collect rainwater and direct it away from the building.

Different roofing materials need to be laid at different minimum pitches depending on the size of each impervious unit. For example, shingles need a large overlap and a steep pitch to shed water effectively; single sheet steel roofing can be laid just sufficiently pitched to drain water away.

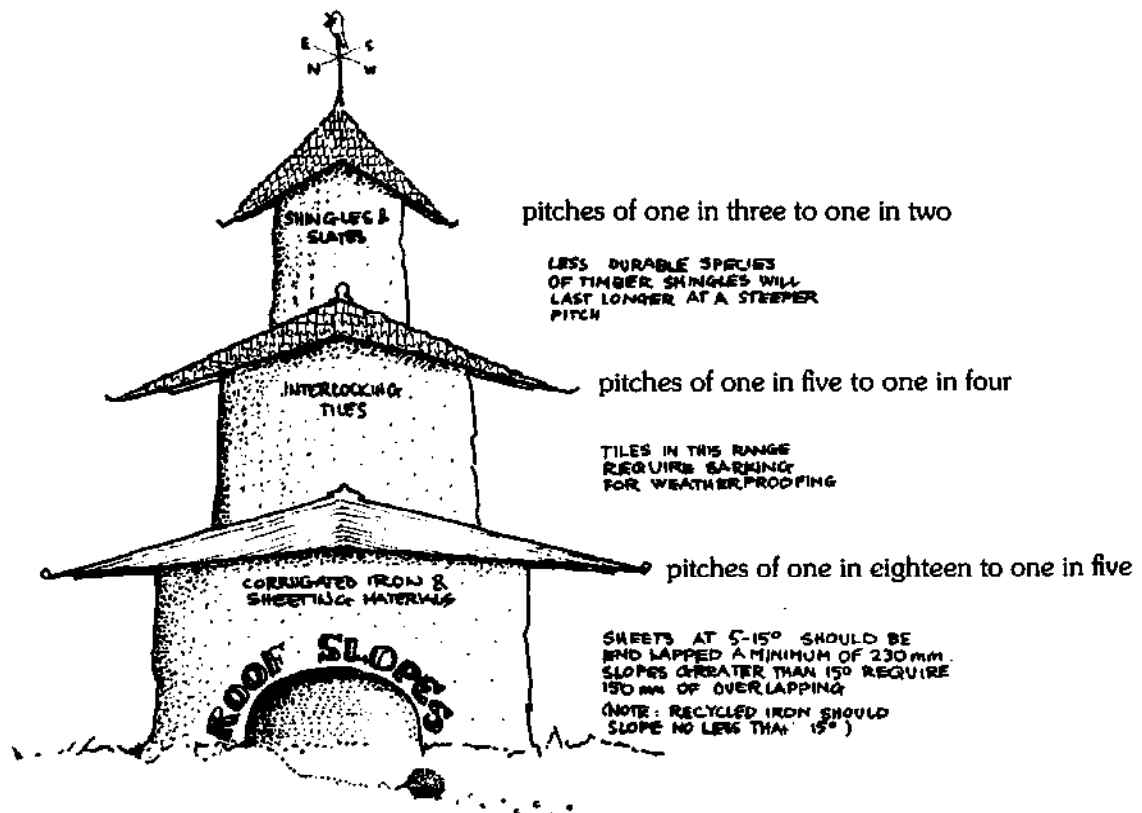

RECOMMENDED PITCHES FOR DIFFERENT ROOFING MATERIALS

Some small component roofing materials need a further impervious barrier such as building paper directly underneath them to assist in weatherproofing.

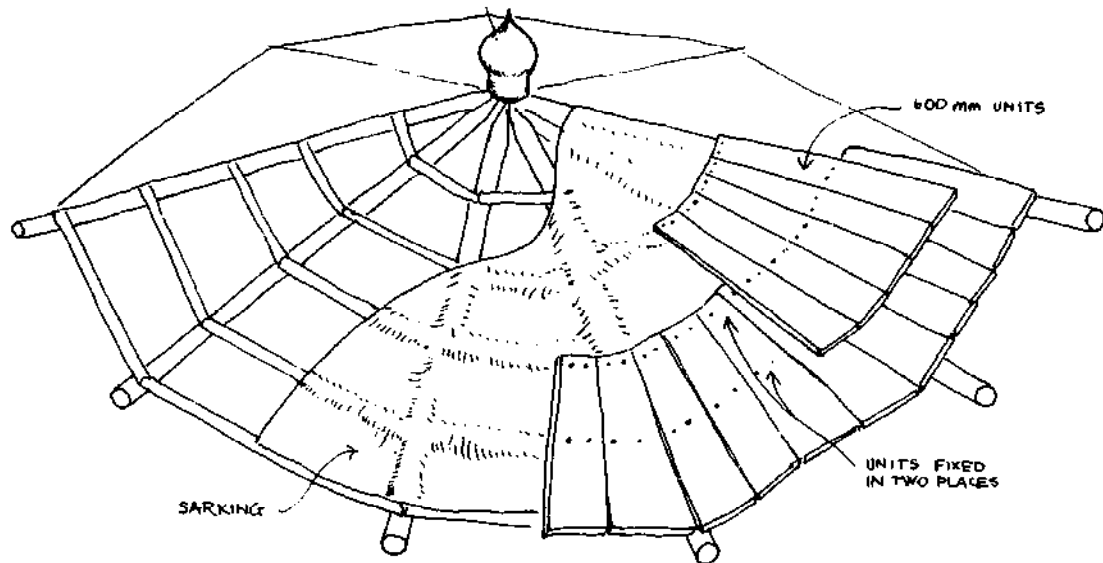

WEATHERPROOFING A SHINGLE ROOF

This diagram shows an example of a roof construction using small overlapping units such as shingles. The spacings shown are suitable for 600 mm long units, fixed on battens at 250 mm centres in two places, giving an overlap of 350 mm.

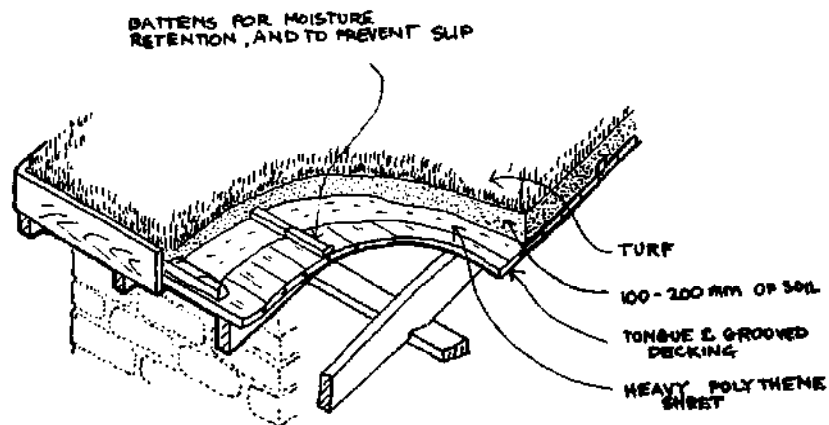

CONSTRUCTION DETAILS OF A SOD ROOF

Sod may be used to provide insulation while being in sympathy with a bushland environment. The drawing below indicates the principles of sod roof construction. Rafters should be sufficient to take the weight of wet sod (sizes used for floor structures should be adequate) and pitched less than 27° to prevent slippage of turf. Special care should be taken in detailing and laying the waterproofing membrane, to ensure that it is not punctured or exposed to sunlight, which will degrade most plastics.

Openings

Opening components are usually regular and square to enable easy action and good weathersealing. This generally means dressed timber should be used for door and window frames and the like.

Frames should have a reasonable degree of stiffness, inherent in their size or utilising the rigidity of the frame or wall they are anchored into. A common size of door and window frame in timber construction is 30 mm thick, allowing for a 12 mm rebate for a door stop. Sills require greater durability than jambs and heads, due to

their exposure, and are commonly made of 75 mm thick seasoned hardwood stock (generally tallowwood). The same applies to timber thresholds.

Included in the weather sealing of any opening is the use of flashings or strips of impervious material fixed in such a way as to aid weathersealing of joints.

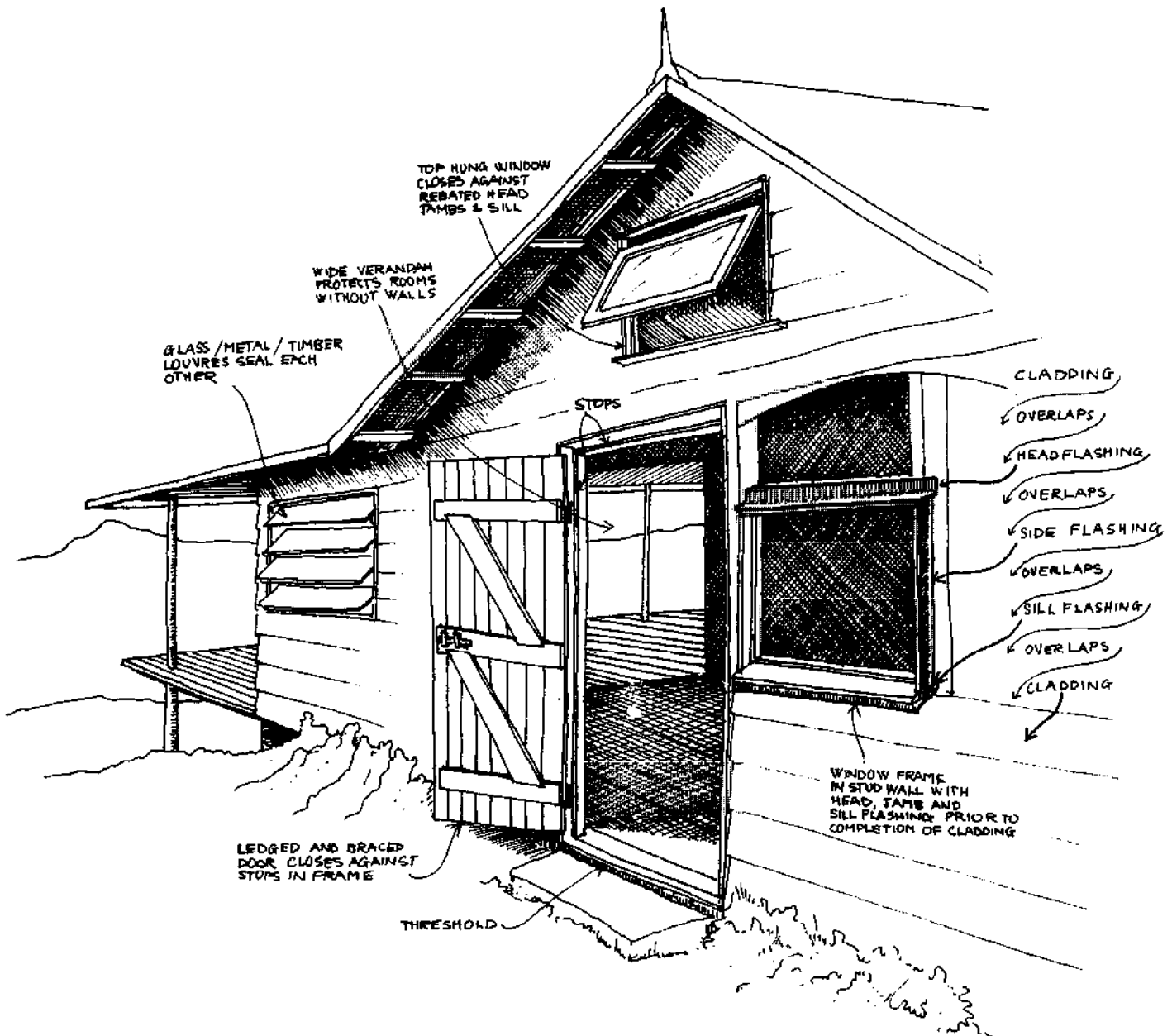

PRINCIPLES OF WEATHERPROOFING OPENINGS

THIS DRAWING ILLUSTRATES SOME OF THE PRINCIPLES INVOLVED IN MAKING AN OPENING IN A WALL, NAMELY, SEALING AN OPENING COMPONENT AGAINST A WEATHERSTOP, AND USING THE PRINCIPLE OF OVERLAPPING IN FLASHINGS, COMPONENTS AND DESIGN (VERANDAHS AND EAVES).

In masonry walls, frames should be plugged or nailed into timber blocks built into the wall. Barbed wire can be stapled to frames which have been positioned and be carried through the mortar joints in the blockwork or stonework as it is constructed.

Recycled bricks may be used as sills in earth masonry construction.

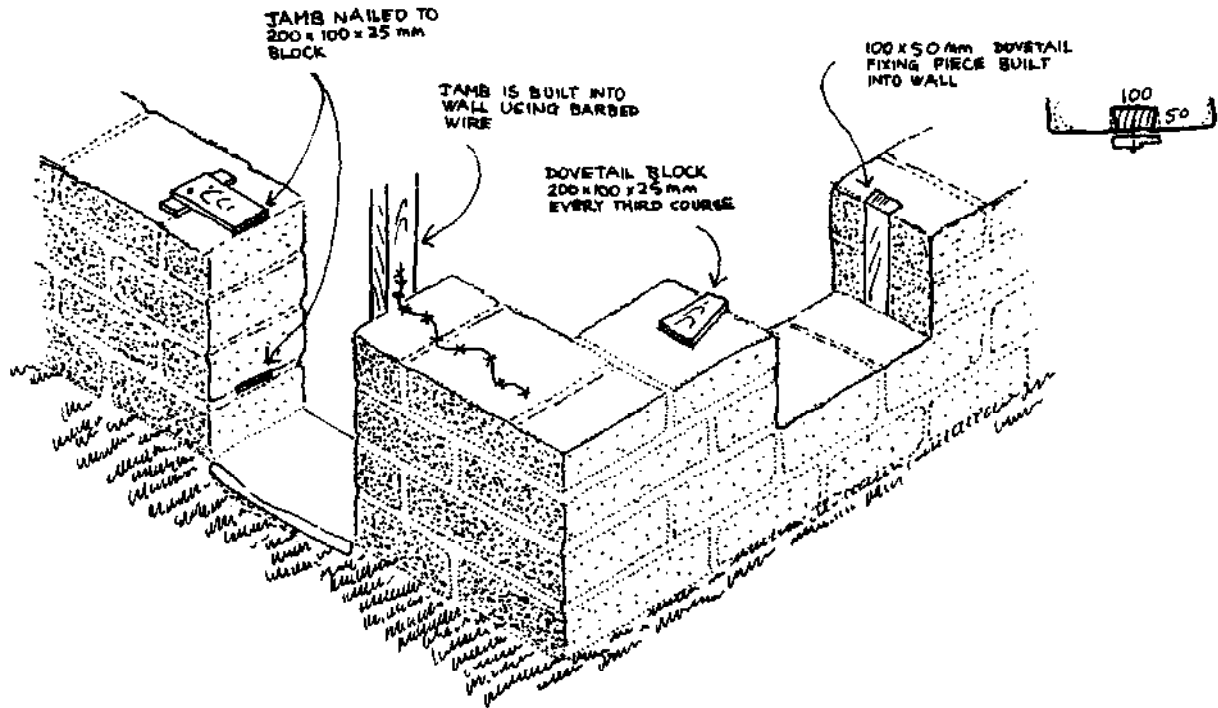

TIMBER FIXINGS TO EARTH BLOCKWORK

SERVICES Water Supply

Generally, the most important consideration for any water source is purity. The homebuilder is strongly advised to check with the local Health Surveyor for evidence or possibility of contamination in any ground water source to be used for drinking. If there is any doubt as to the bacteriological quality of the water it should be boiled prior to use for drinking.

In addition it is useful to know the dissolved mineral content of any supply, as hard water will eventually choke hot water cylinders and lines with scale deposits.

The following sources of supply may be available, and all could be subject to contamination depending on pollution factors.

SPRING WATER, which is usually of good quality but invariably contains dissolved minerals. It is generally safe for drinking.

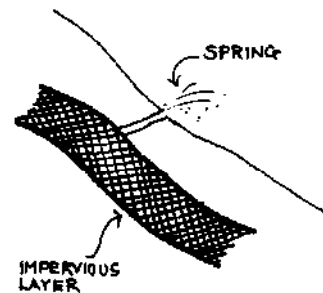

DEEP WELL WATER,

which is similar to spring water, being protected from contaminants by the impervious layer above it (if there are no faults or fissures in the impervious layer). This type of well may be quite shallow provided it still penetrates an impervious layer.

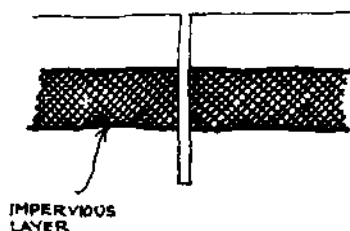

SHALLOW WELL WATER,

which comes from soil having no overlying impervious layer, no matter what its depth. Water from these wells has a high risk of contamination.

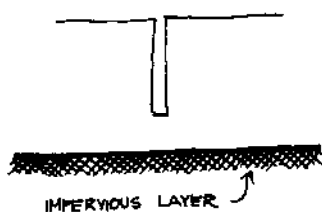

DAM WATER,

which should be tested for purity before use.

STREAMS AND CREEKS,

which should also be tested for purity before use, especially if there is human habitation in the watershed.

ROOFWATER CATCHMENT,

which is an excellent source of water for all purposes. If debris contaminates the first flush of roof water after a long period without rain, use a diverter to shed the first five minutes of rainfall. Eaves gutters should never fall less than 1:480, and should slope 1:50 where leaves and debris build up between rainfall periods. Standard domestic sizes are 115 mm gutters and 75 mm downpipes.

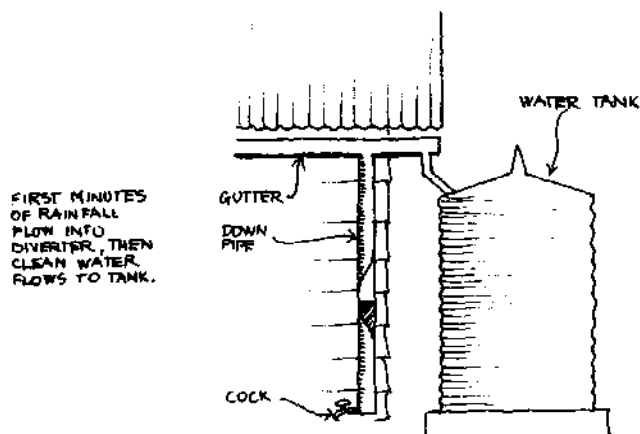

RAINFALL DIVERTER

Tanks should be covered to protect water from contamination.

Inquiries should be made locally to determine the minimum water storage capacity needed.

To maintain water purity, it is important that no potential contaminants be allowed to enter the catchment. Wells and springs should be located at least 30 metres from all sources of pollution. This includes cesspits, sullage water, roadways, livestock, gardens receiving organic or chemical fertiliser, and swamps. Removal of vegetation over catchment areas can also contribute to surface run-off, which may contaminate water supply.

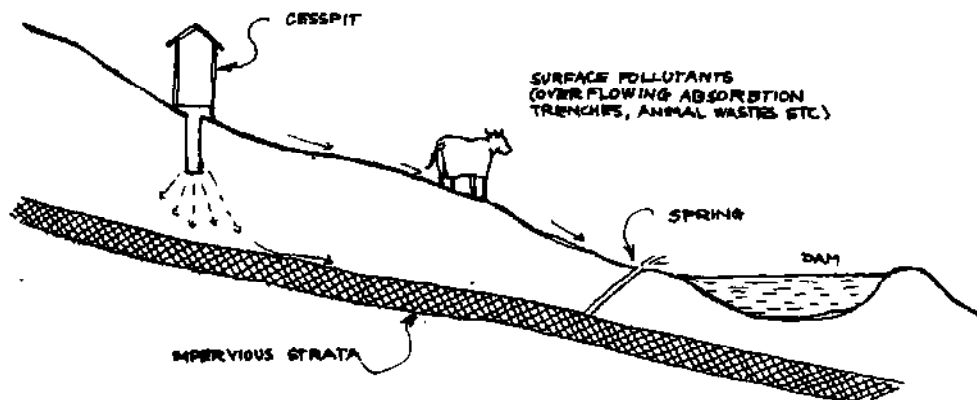

TYPICAL POLLUTANT SOURCES

NOTES

- 1) Plumbing connected to onsite water sources may be done by the homebuilder.
- 2) Plumbing connected to town water supply should be done by a licensed plumber in accordance with Ordinance 46.
- 3) Soil conservation officers will advise on damsites without charge if you are a primary producer.
- 4) The Water Resources Commission will advise on damsites for a \$20 to \$30 fee.
- 5) Subsidies from the Water Resources Commission are available to primary producers for the construction of water supply and storage equipment, and are usually 25 per cent of the cost incurred, to a maximum of \$1000.

Hot Water Supply

Apart from the normal gas or electric systems available for water heating, the homebuilder has the option of utilising renewable forms of energy such as sunshine and firewood. The illustration shows a combined solar/fuel stove boosted hot water system, each source complementing the other over the yearly seasonal cycle.

HOT WATER STORAGE

Central to both systems is a well-insulated hot water storage tank, shown mounted in the roofspace. It should be sized to suit the numbers of occupants and, if solar energy is the only input, storage for cloudy days.

A 300 litre storage tank is common in domestic solar installations, though less storage capacity can be tolerated where hot water use is lower or where fuel stove boosting is normal on cloudy days.

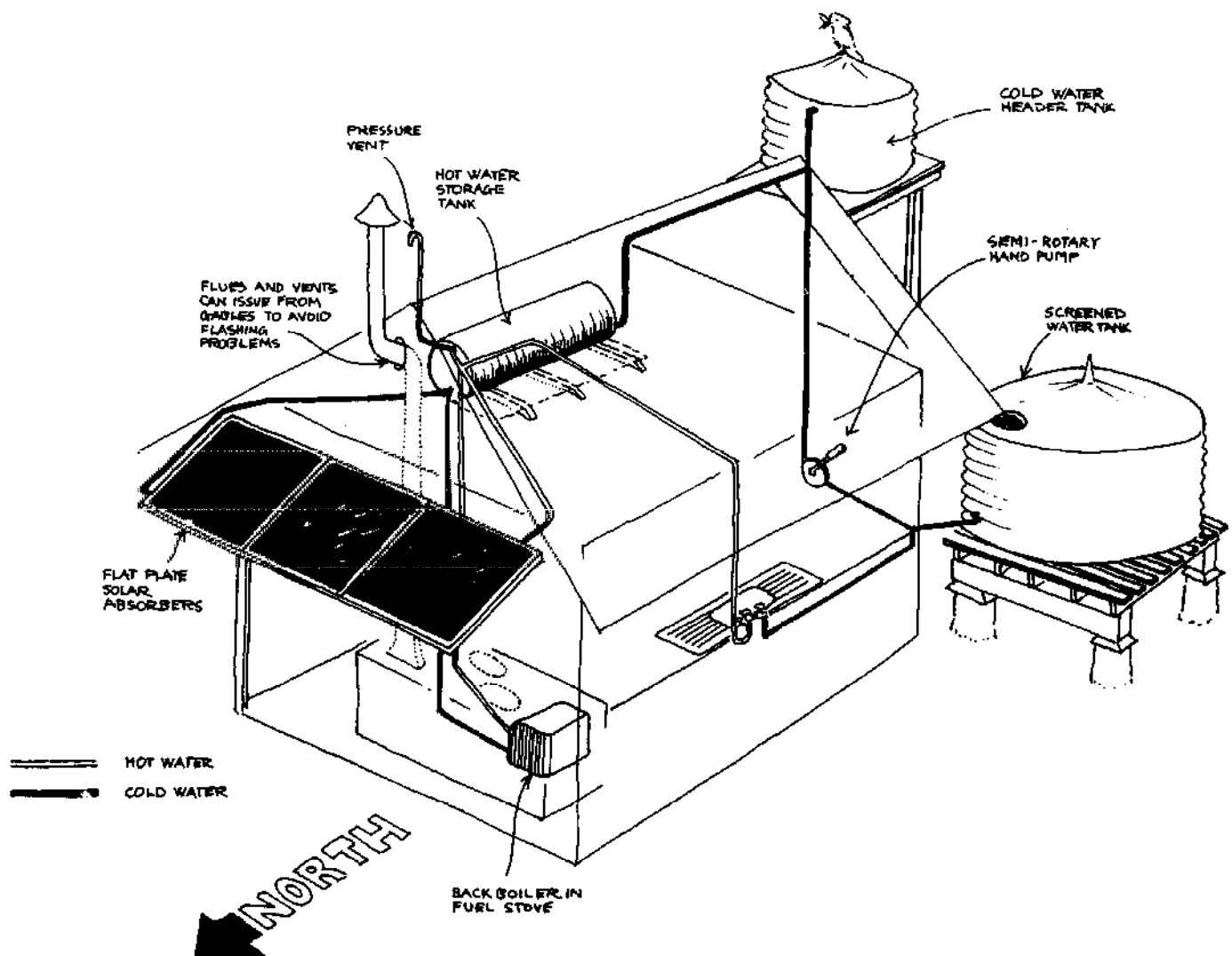

HOT WATER SYSTEM

A COMBINED SOLAR/FUEL STOVE HOT WATER INSTALLATION OPERATING ON THE THERMOSYPHON PRINCIPLE.

i.e.

$$\text{Capacity (litres)} = N \times \text{AHW} \times \text{NS}$$

where N = number of users
 AHW = average hot water use per person per day (litres)
 NS = number of days in a row without sun.

Both solar and fuel stove systems rely on the thermosyphon effect to function: hot water rises from a heat source to a storage tank. Thus it is important that the base of the storage tank be mounted higher than either the top of the solar collectors or fuel stove booster, to eliminate back flow, and that hot water pipes rise continuously from source to storage to assist circulation.

Hot water lines should be insulated and as short as possible between source and storage to minimise heat loss. In addition, the storage tank should be vented to allow pressure relief, with an open-ended 12 mm standpipe raised 600 mm above the level of any header tank.

Generally soft water should be used in hot water systems (e.g. rainwater) to minimise deposits of scale in pipes and tanks.

Plastics should not be used for hot water pipes as expansion and contraction of the lines may cause problems.

SOLAR HEAT SOURCE

The most common type of collector is the black flat plate, consisting of a glazed and insulated box containing blackened pipes through which water flows to a storage tank. There are many variations of such apparatus available commercially and for home construction, all working on roughly the same principle, though efficiencies can vary considerably. The collector should be unshaded for most of the day, and facing due north, though slight deviations will not seriously affect the performance. The panels should be mounted on a slope of 30° to 34° throughout New South Wales, though this can be varied depending on the season (and solar altitude) that most input is required (summer or winter maximum) and the available roof pitch. A minimum of 10° is needed to operate the thermosyphon.

Allow one square metre of collector per person, and ensure the panels are adequately anchored to the roof or supports. Minimally sized roof structures may require additional support to cope with the weight of storage tanks and/or absorbers.

FUEL STOVE HEAT SOURCE

Fuel stove heat sources generally utilise a water filled jacket or a pipe coil surrounding the firebox to supply hot water. The homebuilder should ensure that the water pressure from any header tank does not exceed that recommended by the manufacturer. The same thermosyphon principles which apply to solar systems apply to fuel stove installations, from firebox to hot water storage tank.

Circulation pipes should be insulated, and the system must be filled with water before lighting the fire.

LP Gas Plumbing

LP gas can be used for lighting, cooking, space and water heating. Because of its high flammability certain guidelines should be followed:

(a) Cylinders up to 4.5 kg can be stored inside and connected with flexible rubber hose to the appliance. It is best to keep the rubber hose as short as practicable to minimise the chance of it being damaged by animals or people walking across it. For every appliance a

separate cylinder and low pressure regulator is needed. Initial connections should be made by a licensed person but refilling of cylinders can be done by the owner-builder at a suitable LP Gas supply centre.

(b) Cylinders greater than 9 kg should be located outside at least one metre away from any opening into a building on a well-ventilated firm foundation and protected from excessive rises in temperature or possible physical damage. They should be fitted with a low pressure regulator and be fitted by a licensed LP gasfitter. Only when a licence has been issued will the gas be delivered. Cylinders greater than 9 kg connected with copper tube will service several fixed appliances.

Drainage and Sanitary Works

SULLAGE DISPOSAL

Sullage is considered to be all waste water from fittings EXCLUDING effluent from W.C.s, septic tanks and stormwater. It includes water from baths, sinks, tubs and floor wastes, which is generally directed into sewers where available, or a variety of absorption treatments. As with water from town supply, sullage drains connected to town sewers require the services of a licensed drainer, while onsite sullage works may be done by the home builder.

In the siting of disposal systems certain features need to be avoided, such as steep slopes, waterlogged or "wet" areas, proximity to natural drainage lines and proximity to water supply.

Approved methods of sullage disposal are:

(a) Soil absorption. This is suitable for soils having moderate to highly absorbent properties.

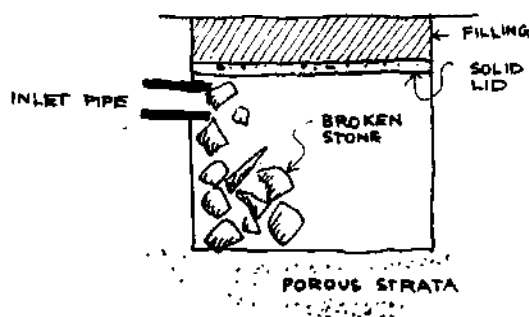

AN ABSORPTION WELL

(b) Transpiration beds. These are generally used in heavy-clay areas and unless the land is reasonably level, excavation may have to be quite deep to obtain a level transpiration area. The alternative to deep excavation is to provide a retaining wall around the perimeter. In these situations, longer absorption trenches constructed parallel with the land contour to achieve the level surface would be more practical.

Transpiration beds perform best in areas of low rainfall and high evaporation. They should have maximum exposure to wind and sun.

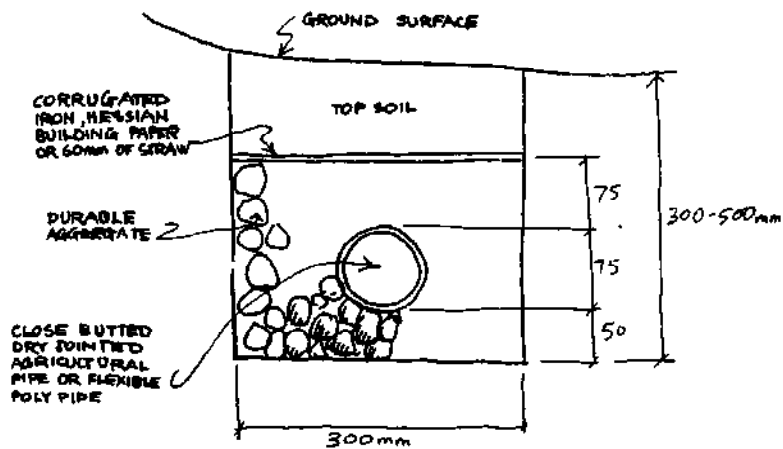

AN ABSORPTION TRENCH

The steps for design and construction of sullage works are:

- 1) Determine absorptive capacity of soil in drainage area (see test).
- 2) Estimate numbers of people using facilities.
- 3) Calculate absorption area required.
- 4) Choose manner and method of works.
- 5) Discuss the plan of the drainage layout with the local health surveyor before construction.

This test is merely an indication of the absorptive capacity of the soil. Seasonal moisture content of the soil at the time of testing must be taken into account in assessing test results for the determination of absorption trench lengths and the general means of disposal. First-hand knowledge of local conditions, problems and solutions is essential in assessing the soil absorption qualities of a site.

For the length of trench required, the following calculation is used:

SOIL ABSORPTIVE CAPACITY TEST.

- 1) Dig a hole 300 mm square to the depth of the proposed drain. Allow for a fall of 1:40 from the house fittings.
- 2) Fill the hole with 150 mm of water and allow to soak away.
- 3) Repeat 2 and note the time taken for water level to drop 25 mm.

From the graph, estimate recommended maximum absorption per 300 mm of trench per day.

$$L = \frac{S \times N}{M}$$

where L = length of trench
 S = amount of sullage water per person per day (20 litres is a common figure)
 N = number of occupants
 M = maximum absorption (from graph)

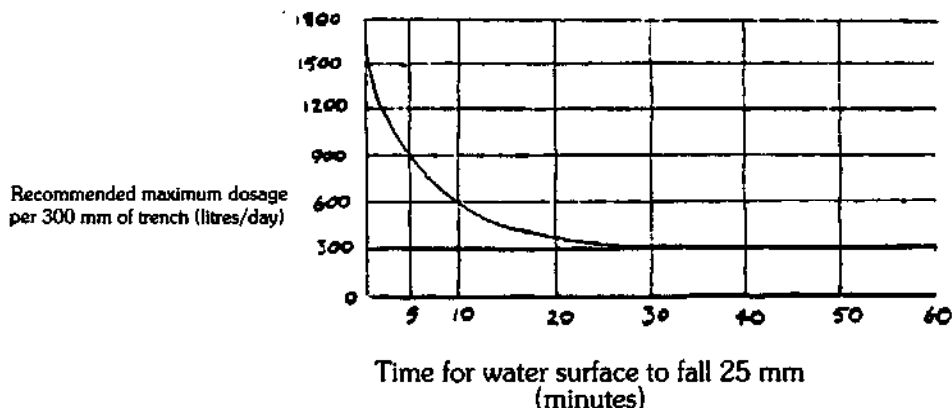

From the follow table choose the best method of disposal of your soil type, based on the results of the previous absorption test.

time for water surface to fall 30 mm	Type of soil	Recommended method of disposal
more than 10 mins	non-absorbent	transpiration area and evaporation
15-30 mins	poorly absorbent	absorption trench & transpiration area
5-15 mins	moderately absorbent	absorption trench & transpiration area or absorption well, or both
less than 5 mins	absorbent	absorption trench with or without transpiration area or absorption well, or surface irrigation

NOTES

- 1) Discharge kitchen wastes through a grease trap, which should be cleaned regularly, as grease will ultimately block the soil pores and destroy its absorptive capacity.
- 2) Multiple absorption trenches should be spaced two metres apart and run with the contours of the site.
- 3) Plants help in the removal of ground water by evapotranspiration. Vegetables grow well in absorption areas, and water tolerant vegetation such as Prairie Grass, Clover and Boobiala can be used for overwet soils. (See Appendix 4 for suitable native tree species).

CESSPITS

It is important that human wastes be disposed of without risk of contamination to either the homebuilder or the community, and there are some basic principles to observe.

Seepage into drinking water supplies, either for household or stock consumption, and airborne insect vectors are the two major possible causes of contamination. Thus cesspits must not be built where they can pollute water supplies or where the level of ground water is above the level of the bottom of the cesspit. Homebuilders should discuss with their Health Surveyor the most suitable location. Surface runoff can cause a cesspit to overflow, and hence a bank 150 mm high should be formed around the opening to prevent water entry. In heavy rainfall areas, the high side of the cesspit should be drained by means of a trench, and water dispersed away from the opening.

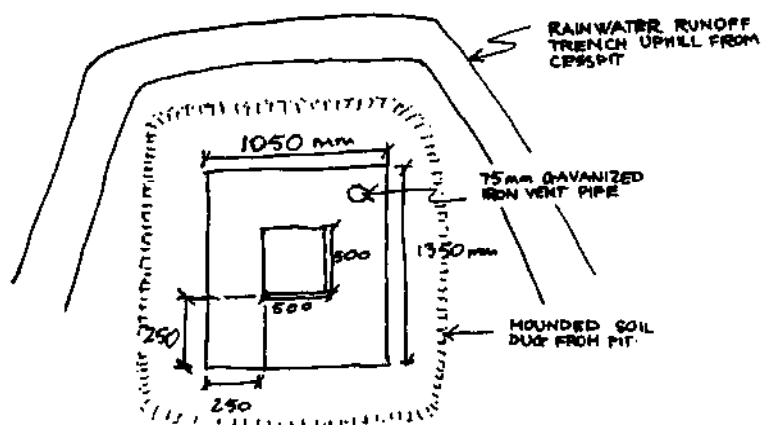

BASIC PLAN OF TYPICAL CESSPIT

In addition, the cesspit should be deep, dark and flyproof. Tongue and grooved boards make a good light proof flooring, which should be sloped downhill to facilitate runoff. The opening should always be covered properly when not in use by means of a closely fitting lid. Good practice is to provide a flyscreened, weatherproofed vent to dissipate odours and aerate the contents.

When the pit is filled to within 450 mm of ground level, cover the contents with lime or sawdust, followed by clean earth 300 mm above the ground. Wait for the contents to break down, then plant a tree on the site.

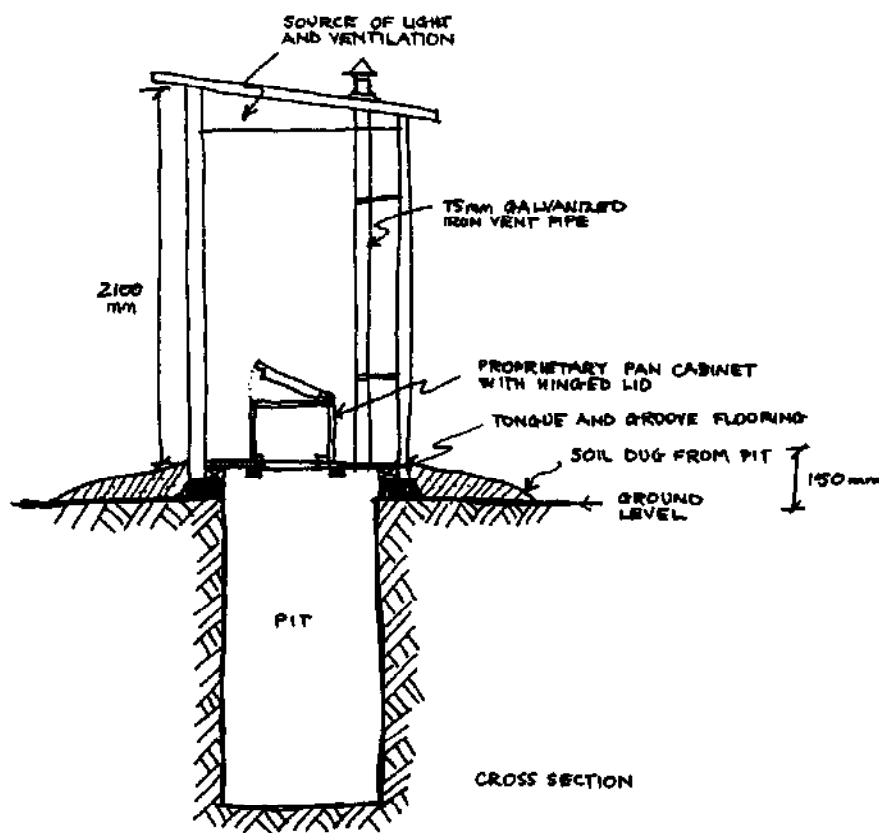

CESSPIT WITH CABINET ON LEVEL SITE

NOTE

Cesspits are prohibited on any premises within a sanitary scavenging district. In these districts the Council must provide for the removal and disposal of night soil.

COMPOSTING TOILETS. With the exception of electrically and chemically operated proprietary models, composting toilets are not yet approved for use. Home builders wishing to construct a composting toilet should choose a well-documented design and consult the Council health surveyor, who will arrange for the toilet to be tested in use over a specified period by the Health Commission.

Electrical Work

CONNECTION TO 240 VOLT AC PUBLIC SUPPLY

Where a public supply is available and the homebuilder wishes to connect to it, wiring must be carried out by a licensed electrician according to the Australian Standard Wiring Rules (AS3000 — Part 1).

POSSIBLE FUTURE CONNECTION TO PUBLIC SUPPLY

Where a public supply is available and connection to it may be desired in the future then it is recommended that wiring be installed in accordance with the AS Wiring Rules (AS 3000 — Part 1) for medium voltage AC supply.

EXTRA LOW VOLTAGE ELECTRICAL INSTALLATION

Where a 240-volt mains supply is not available or not required, an extra low voltage (commonly 12-volt) supply can be installed by the home builder. While the 12-volt electrical system is relatively simple and safe to install, it is important that care is taken as faulty connections and fittings can cause poor performance and rapid deterioration of relatively expensive supply and storage components.

The following is an outline of the principles of extra low voltage installation design:

1. *Maximum current demand* is estimated. This determines cable and fuse sizes.
2. *Maximum energy demand* is calculated (current per hour). This determines battery capacity required (in amp hours) and the appropriate charging system (solar cells, wind or water sources, internal combustion generator, etc.).

ESTIMATING DEMAND

In most electrical installations, every appliance will not be working simultaneously, and hence the system should be designed to meet the most probable maximum demand rather than the potential total load.

In a mains supplied system it is necessary only to consider the load connected in terms of the current that will flow through the cables. However, in a battery system, time is a vital factor since the battery stores a certain amount of energy which can be dissipated by a low load over a long period as well as by a high load over a short period.

The *maximum current demand* is the sum of the current drawn by each appliance likely to be operated simultaneously, and is expressed in amperes (amps). Alternatively, the individual wattages or voltamps can be summed, and divided by the voltage (12) to give amps. Some loads draw a higher current than their watt ratings indicate (e.g. fluorescent lamps and refrigerators) so it is preferable to use the current rating of the appliance rather than the watt rating.

The *maximum energy demand* is the energy that is expected to be called upon from the battery system between charges. It is calculated by adding the load (in amps) multiplied by the operating time (in hours) of each appliance that will be used during the discharge period. This is the required capacity (in amp-hours) of the battery. A suitably sized charging system should be

matched with this demand to avoid flat batteries, and consequent cell damage.

INSTALLATION

The plague of all electrical systems is that the cables through which the current flows are not perfect conductors, and have a low but significant resistance. (This same resistance produces heat in an electric radiator and light and heat in a filament lamp.) Cable resistance causes a loss in power (given off as heat in the cable) and a drop in voltage to the appliance, which is especially significant in a 12-volt battery system.

Consider a 40-watt incandescent lamp. The current drawn on a 240-volt system is 40 divided by 240 = 0.17 amps with a cable loss of 0.03 watts for a given length. The current drawn on a 12-volt system will be 40 divided by 12 = 3.3 amps, the cable losses being 11.1 watts for the same length.

These power losses may be minimised, but not eliminated, by the followed procedures:

- 1) Keep cables as short and direct as possible. Locate the battery at the geographical centre of the installation, but in such a way that the safety of the battery storage is maintained.
- 2) Use conservative (i.e. larger) rated cables to keep temperatures low and hence voltage loss minimal. Ventilation around cables helps.
- 3) Observe good connection practice. Joints should be free of dirt and oxide coatings. Screwed connections should be tight and defective switches and sockets should be replaced.

Once, the maximum demand for each circuit has been determined, suitable cable sizes should be selected. It is usually more practical to use one cable size (e.g. 20-amp) and arrange the number of circuits so that the cable is not overloaded, and is preferably underloaded. Although 12-volt automotive cable can be used, it may be preferable to use 240-volt cable (say, 20 amp) as it has superior mechanical protection and lends itself to more secure connection to switches and outlets which will probably be 240-volt equipment (i.e. normal switches, outlets and plugs).

PROTECTION AND SAFETY

The electrical system must be protected from damage in a manner which minimises disruption if a fault occurs.

Wiring should be located so as to avoid accidental damage, and should be secured so that it is supported by the structure without strain. Do not nail through concealed wiring! Cables should not be joined between outlets, switches and so on, but should be looped from outlet to outlet. This minimises joints, increases reliability, and also allows damaged cable to be replaced if needed by using the old cable to draw a new one into position.

Electrical protection is necessary to prevent damage to the wiring in the event of, say, a short circuit. The same applies to the battery system. In order to minimise disruption, the protection should isolate only the fault area from the supply. This is achieved by using fuses to protect cables, and by using a number of circuits (cables) to supply the installation. Two or more circuits should be used, depending on the size of the

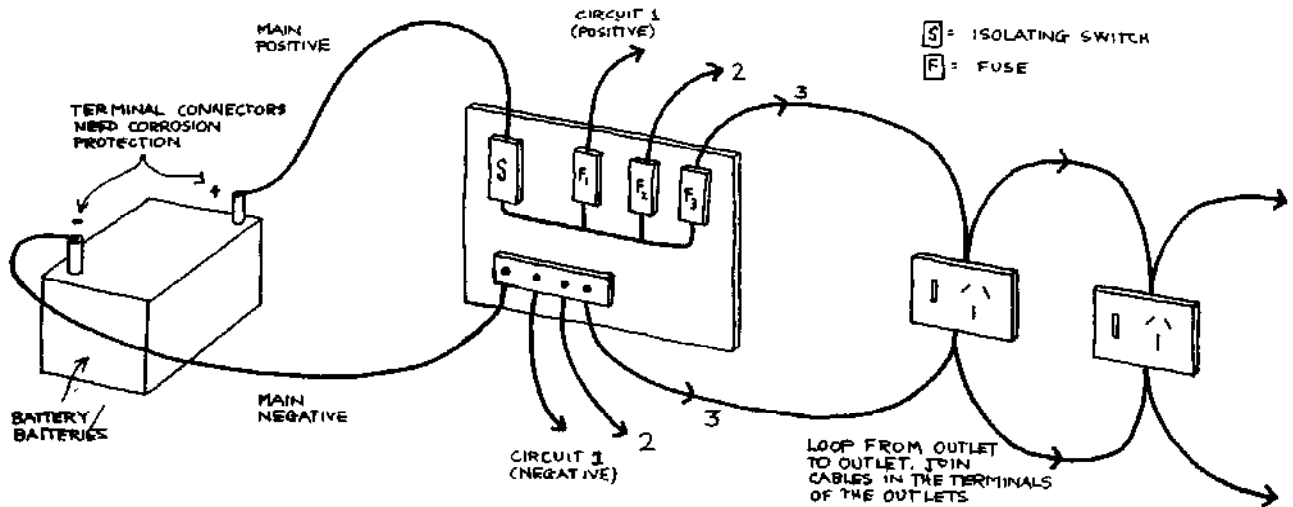

CIRCUIT DIAGRAM

installation. One circuit could be used for fixed lighting, and another (or others) for power outlets. Each circuit should be protected at its source (near the battery) by a fuse rated to the smaller of either the maximum load to be accepted on the circuit or the current rating of the cable.

The fuse should be located in a convenient position as close to the battery as possible. An automotive or 240-volt fuse can be used, and fuses or fuse wire of the correct rating must be used. **DO NOT USE NAILS.** The fuse board should be close to the battery, as the cable from the battery to the fuse board may not be protected by a fuse.

The cable from the battery to the fuse board should be rated for the maximum demand of the installation, and an isolating switch should be included on the fuse panel for circuit maintenance.

WIRING

Conventionally, red or brown insulated wire is used for the active or positive link, and black or blue is used for the neutral or negative (in 240-volt installations, a green, or green/yellow striped earth wire is also used). It is necessary to break only one cable in order to operate or isolate an appliance, and again, conventionally, it is the red or positive link that is switched. All negative conductors will then return to a common point which is directly connected to the battery system negative terminal. The negative link could be easily incorporated into a 240-volt fuse panel, or can be fabricated from a brass bolt, nut and washers, or a brass bar with holes and cable clamping screws. If three circuits are used, then the three negative cables will return to the negative link.

Each positive cable will commence from its fuse and run to each switch/outlet by looping. The negative will run parallel and outlets will be in parallel to each other (see diagram). Cable savings can be achieved if switches are integral to the equipment.

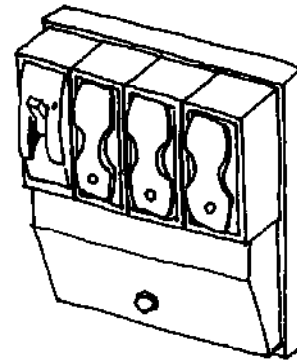

TYPICAL PROPRIETARY SWITCHBOARD INCORPORATING A NEGATIVE LINK

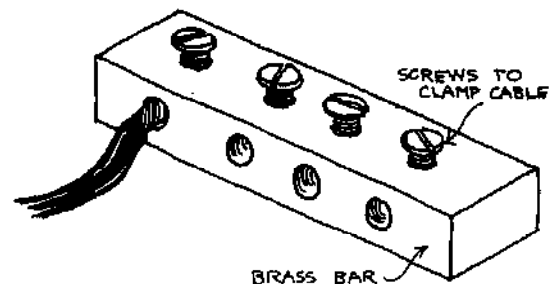

A NEGATIVE LINK

Fireplaces, Stoves, Chimneys and Flues

A prime consideration of fireplace design and construction is that combustible parts of the building are protected from the heat of the fire, and damage from dislodged fuel. This section describes the principles of fireplace, hearth and flue design, and the installation of solid fuel stoves. More complete information is contained in *Domestic Fireplaces and Chimneys*, Notes on the Science of Building No. 31 from the Experimental Building Station.

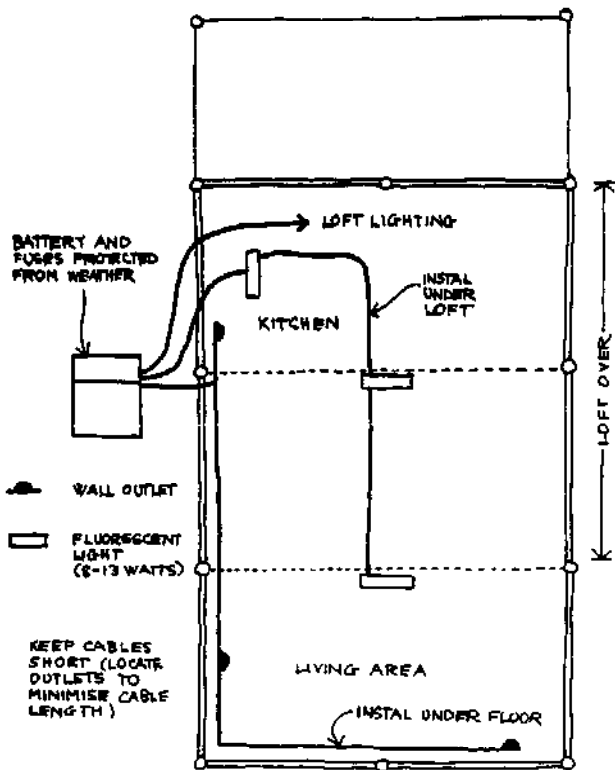

SCHEMATIC WIRING DIAGRAM

USE

Any electrical system where the supply is intermittent should be used conservatively. Obviously the current and energy demands will be reduced by high efficiency equipment. Fluorescent lighting (with self-contained inverters) is much more efficient than incandescent lighting — more light is produced for less energy — and should be used in preference to incandescent lighting.

Fittings should be placed close to the task area to ensure adequate visibility, but should not be used in isolation — there should be some background lighting to reduce contrast fatigue.

Batteries should not be abused, by either allowing them to become fully discharged, or recharging too rapidly. Manufacturers' instructions for installation and maintenance should be strictly observed.

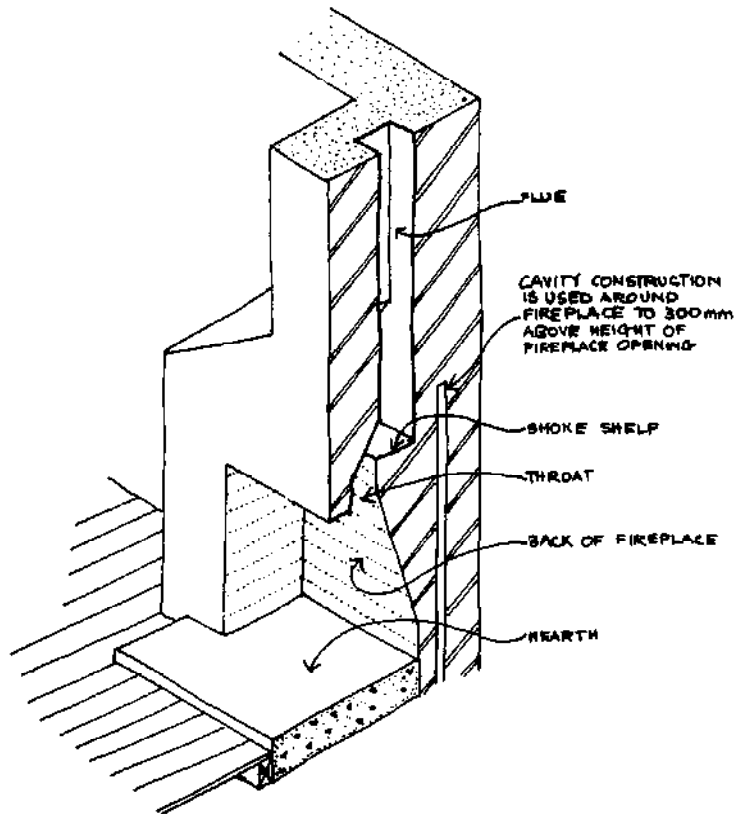

ELEMENTS OF A FIREPLACE

MASONRY FIREPLACES AND STOVES

Fireplaces and chimneys within the house should have a high degree of permanence and fire resistance. Bricks, stone, no-fines concrete or cement stabilised earth can be used, but in all cases should be lined with brickwork (preferably firebricks) or fire-resistant mortar. Chimneys should also be lined with rendered brickwork or with some other heat-resisting mortar. (Failure to use an adequate lining will cause premature deterioration of the fireplace structure. However, if fire-resistant linings are unavailable it would be wise to limit the intensity of fires in the grate.)

SUITABLE MORTARS FOR MASONRY FIREPLACES (Kearn & Magers, 1978)

	Cement	:	Sand	:	Lime
Stone laying	1	:	3	:	-
	1	:	½	:	4½
Brick and concrete block	1	:	6	:	1
Chimney render (or parging)	1	:	4	:	1
Mud block	1	:	9earth (add sand to reduce clay content to between 25 and 50 per cent)		

EXTERNAL FIREPLACES

Some simplification is possible if the fireplace and chimney are located externally. The fire may be contained in a wide range of incombustible constructions, including sheet metal (corrugated iron is used for the traditional bush chimney), provided that surrounding timber work is not subject to high temperatures, and long service life is not required.

The hearth should have a minimum thickness of 155 mm under the fireplace opening and extend at least 300 mm beyond the front of the fireplace opening and 150 mm beyond the side of that opening. The upper surface should not slope away from the grate of the fire. Where the fireplace is free standing a suitable extension would be 300 mm all round.

The fireplace should be constructed with a sloping back and should function properly if built to the following dimensions for fireplaces up to 1090 mm wide (see illustration):

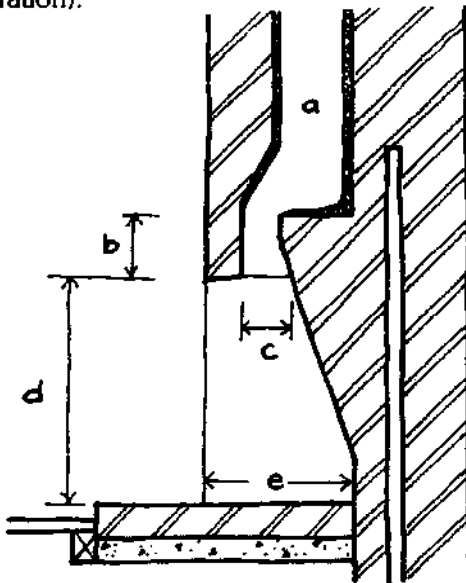

PROPORTIONS OF FIREPLACE ELEMENTS

- a = Area of flue: 1/8 to 1/10 area of fireplace opening for unlined flues
- b = height of throat: 150 to 200 mm
- c = depth of throat: approx. 100 mm
- d = height of opening: 685 to 770 mm
- e = depth of fireplace: 400 to 450 mm

FLUES

Customarily, the flue is 250 x 250 mm or 10% of the area of the fireplace opening, whichever is the greater, and is lined internally to a thickness of 12mm if constructed of masonry (see table of suitable renders). For effective operation, chimney stacks should extend 300 to 600 mm above any roof ridge lines within 6 metres.

INSTALLATION OF A SOLID FUEL STOVE

Solid fuel stoves are commonly used in rural areas for cooking, hot water and space heating. The following notes should be read in conjunction with the section on Hot Water Supply if the stove is to be used as a water heater.

The stove should be placed on a firm foundation of bricks, stone or concrete, leaving access for hot water connections and a wall vent, if the range is to be built in.

Flues are commonly of galvanised steel, 100 to 125 mm in diameter and often sleeved with a wider pipe where they pass through roof or ceiling spaces, to prevent contact between the structure and the hot flue. Flues should stand at least 300 mm away from combustible wall linings.

Where possible, flue pipes should issue from walls or gables to avoid flashing problems with the roofing material, and spark arrestors should be fitted if surrounding vegetation poses a fire risk.

In addition to these design considerations, care should be exercised in the use of fireplaces and stoves. Storage areas for combustible materials should be provided away from sources of flame, and outside any habitable room. Light sources involving naked flames should be in a fixed, safe position.

APPENDIX 1

Policy on Multiple Occupancy

The Department of Environment and Planning's Circular 44 is intended to give guidance to Council when formulating their policies on Multiple Occupancy of Farms.

To: All Councils outside Sydney Region and Blue Mountains, Camden, Campbelltown, Colo, Gosford, Wollondilly and Wyong Councils.

CIRCULAR NO. 44

Dear Sir,

POLICY — MULTIPLE OCCUPANCY ON FARMS

On 7th November, 1979, Circular No. 35 (Interim Policy — Multiple Occupancy on Farms) was circulated to the above listed Councils. Since that time there has been considerable response to the Interim Policy from Councils and the Local Government and Shires Associations Committee on Local Government Regulations and Alternative Lifestyle Developments.

2. Full background details to the multiple occupancy issue and reasons for adoption of the Interim Policy are included in Circular No. 35.

3. On the basis of response to the Interim Policy a formal Policy for Multiple Occupancy on Farms, together with a standard enabling Clause, has been prepared and is presented in this Circular.

4. Listed below are the policy statements on which the standard enabling Clause was based and which are now adopted as Planning and Environment Commission policy for multiple occupancy. In each case the policy statement is followed by a suggested subclause and/or explanatory notes.

POLICY ONE: THE NEW SOUTH WALES PLANNING AND ENVIRONMENT COMMISSION SUPPORTS THE MULTIPLE OCCUPANCY, ON A CLUSTERED OR DISPERSED BASIS, OF RURAL PROPERTIES IN COMMON OWNERSHIP AS AN APPROPRIATE LAND USE FOR RURAL AREAS SUBJECT TO A NUMBER OF ENVIRONMENTAL AND LOCATIONAL GUIDELINES.

1. STANDARD I.D.O. SUBCLAUSE:

Notwithstanding Clause . . . (forty hectares policy) development for residential purposes comprising permanent dwelling or living accommodation may be carried out on land to which this clause applies with the consent of Council subject to compliance with conditions listed in the following subclauses.

POLICY TWO: A COUNCIL MAY ADOPT, AS IS LOCALLY APPROPRIATE, ONE OF THE FOLLOWING ALTERNATIVES FOR THAT AREA WITHIN WHICH MULTIPLE OCCUPANCY ON FARMS CAN BE APPROVED.

A. AREA ZONED RURAL 1(A);

B. DEFINED PORTION OF AREA ZONED RURAL 1(A); OR

C. AREA ZONED RURAL (SMALL HOLDING) 1(C).

2. STANDARD I.D.O. SUBCLAUSE

ALTERNATIVE B: This clause applies to those parts of land in the Parishes of A, B, C, D and E as are situated:

- within the Shire of Farmland; and
- within land zoned Rural 1(a).

Note: Application for multiple occupancy within the designated area should be made through the Council's normal development application process.

POLICY THREE: HOLDINGS TO WHICH MULTIPLE OCCUPANCY STATUS IS GRANTED SHOULD GENERALLY HAVE A MINIMUM AREA OF FORTY HECTARES, WITH AN ABSOLUTE MINIMUM OF TWENTY HECTARES WHERE SUCH IS THE PREVAILING SUBDIVISION LOT SIZE IN THE LOCALITY.

3. STANDARD I.D.O. SUBCLAUSE: The land upon which the development is carried out has an area of not less than the minimum for subdivision prescribed by clause . . . (e.g. Forty Hectares).

POLICY FOUR: FUTURE SUBDIVISION OF ANY HOLDING GRANTED MULTIPLE OCCUPANCY STATUS IS PROHIBITED AS LONG AS IT RETAINS THAT STATUS.

4. STANDARD I.D.O. SUBCLAUSE: Whenever land is developed in accordance with this clause it is and remains unsubdivided either under the Local Government Act, 1919, or the Strata Title Act, 1973, so as to comprise a single parcel.

POLICY FIVE: ANY APPLICANT FOR MULTIPLE OCCUPANCY STATUS ON A HOLDING MADE UP OF MORE THAN ONE PARCEL, PORTION OR PART PORTION SHALL AT THE TIME OF APPLICATION ALSO MAKE APPLICATION FOR CONSOLIDATION OF TITLE.

5. STANDARD I.D.O. SUBCLAUSE: Nothing in subclause 4 shall prevent the Council from determining an application for consent under this clause in respect of land in more than one parcel but any consent granted hereunder shall be subject to the requirement that the land be consolidated into a single parcel prior to the development being carried out.

POLICY SIX: ANY HOLDING SUBJECT TO AN APPLICATION FOR MULTIPLE OCCUPANCY STATUS MUST BE OWNED IN ITS ENTIRETY IN COMMON BY AT LEAST TWO-THIRDS OF ALL ADULTS RESIDING ON THE LAND, OR MUST BE OTHERWISE OWNED ON BEHALF OF THOSE PERSONS.

6. STANDARD I.D.O. SUBCLAUSE: The land upon which the development is carried out is owned in its entirety in common by at least two-thirds of all adults residing on the land or is otherwise owned on behalf of those persons.

Note: "Otherwise owned on behalf of" means equal ownership through a trust-in-common, trust membership, co-operative shareholding, company shareholding, etc.

POLICY SEVEN: APPROVAL FOR MULTIPLE OCCUPANCY STATUS SHALL ONLY BE GRANTED TO THOSE COMMUNITIES ON WHICH EXISTING OR PROPOSED BUILDING DENSITIES DO NOT EXCEED THAT REASONABLY REQUIRED TO HOUSE ONE PERSON FOR EACH HECTARE OF THE HOLDING IN QUESTION.

7. STANDARD I.D.O. SUBCLAUSE: The residential accommodation shall not exceed that reasonably required to house one person for each hectare of the land.

Note: Person refers to both adults and children, permanent residents and temporary guests (short & long term).

POLICY EIGHT: IN CONSIDERING AN APPLICATION FOR MULTIPLE OCCUPANCY, THE COUNCIL SHOULD TAKE ACCOUNT OF ENVIRONMENTAL AND LOCATIONAL MATTERS, INCLUDING:

- ADEQUACY OF ACCESS
- ADEQUACY OF WATER SUPPLY AND DRAINAGE
- ADEQUACY OF WASTE DISPOSAL FACILITIES
- RELATIONSHIP TO NEIGHBOURING LAND USES
- RELATIONSHIP TO EXISTING FACILITIES & SERVICES
- BUSH FIRE RISK
- POTENTIAL EROSION HAZARD
- SITE VEGETATION COVERAGE
- AGRICULTURAL SUITABILITY
- SITING OF PROPOSED BUILDINGS.

8. STANDARD I.D.O. SUBCLAUSE: In considering an application under this clause the Council shall have particular regard to the environmental and locational suitability of the land for the proposed development.

Note: No specific standards on these matters are defined because in each local government area conditions will vary. Councils can choose either to specify standards and include them in an enabling clause, or evaluate each application on its merits and recommend changes to site and development plans where appropriate.

POLICY NINE: HOLDINGS GRANTED MULTIPLE OCCUPANCY STATUS SHOULD BE USED ONLY FOR PERMANENT RESIDENTIAL PURPOSES AND SHOULD NOT BE USED FOR HOTEL, MOTEL, CARAVAN PARK OR ANY OTHER TYPE OF HOLIDAY, TOURIST OR WEEKEND RESIDENTIAL ACCOMMODATION.

9. STANDARD I.D.O. SUBCLAUSE. Whenever land is developed in accordance with this clause, any development for the purpose of a hotel, motel, caravan park, or any other type of holiday, tourist or weekend residential accommodation is prohibited.

Note: This policy should not be used to prohibit temporary accommodation associated with teaching or workshop activities proposed for bona fide new settler communities. This clause is designed to prevent exploitation of the policy for commercial purposes not associated with the alternative lifestyles of new settlers.

POLICY TEN: MULTIPLE OCCUPANCY HOLDINGS IN EXISTENCE PRIOR TO GAZETAL OF AN ENABLING CLAUSE THAT WERE DEVELOPED WITHOUT COUNCIL APPROVAL, SHOULD BE LEGALISED UNDER THE ENABLING CLAUSE IF THEY MEET THE REQUIREMENTS OF THE CLAUSE.

10. STANDARD I.D.O. SUBCLAUSES: (A) Permission is hereby granted in respect of each of the parcels of land described in Schedule . . . (of the gazettal notice) for the following development:

- a) development of the land for residential purposes comprising permanent dwelling or living accommodation; and

b) the use of the buildings in existence on the aforesaid land at the date upon which this clause takes effect for the purposes referred to in paragraph (a).

(B) Permission granted by subclause (A) in respect of any development referred to in subclause (A) shall:

a) operate in relation to the erection of any buildings, so as to permit only the erection of those buildings in existence on the aforesaid land, at the date upon which this clause takes effect; and

b) in addition to its taking effect in accordance with subclause (A) and without prejudice to that subclause, be deemed to have been granted by this order as in force immediately before the day upon which that development was commenced on that day.

Note: Subclause (B)a limits approval to those buildings complete, or substantially complete, at the day of gazettal. Subclause (B)b retroactively legalises the action of building and the use of buildings completed prior to the gazettal date.

(C) Nothing in this subclause shall prevent the application of subclauses 1 to 9 (mentioned in this Circular Letter) in respect of any land the subject of this clause, but in any such application the development permitted by this clause shall be taken into account for the purposes of subclause 7.

POLICY ELEVEN: RESIDENTS OF EXISTING BUILDINGS ON MULTIPLE OCCUPANCY HOLDINGS WHICH HAVE BEEN LEGALISED UNDER THE ENABLING CLAUSE MUST SUBMIT BUILDING APPLICATION TO THE COUNCIL. THE COUNCIL SHOULD ALLOW AT LEAST ONE YEAR SUBSEQUENT TO GAZETAL FOR EXISTING BUILDINGS TO CONFORM WITH REQUIREMENTS.

POLICY TWELVE: ALL BUILDING PROPOSED FOR MULTIPLE OCCUPANCY HOLDINGS APPROVED SUBSEQUENT TO, OR AT THE TIME OF, GAZETAL OF THE ENABLING CLAUSE MUST BE SUBJECT TO THE BUILDING APPLICATION PROCESS AND CONFORM WITH BUILDING REQUIREMENTS.

Note: A Technical Advisory Group (Department of Architecture, Sydney University) has been retained by the N.S.W. Planning and Environment Commission to carry out the Experimental Building Area Programme and produce a series of advisory documents on low cost alternative building technologies and materials. The work is being assessed by representatives of the Department of Local Government, the Health Commission of N.S.W., the Lismore City Council, the Local Government Association, the Australian Institute of Health Surveyors, the Builders Licensing Board and the Building Surveyors Institute. The final report of the group is due after July, 1980 and will be circulated thereafter.

Note: The findings of the Technical Advisory Group are aimed, not at changing existing building regulations, but at assisting in their flexible administration and increasing the acceptability of non-traditional low cost housing by Council Health and Building Inspectors.

POLICY THIRTEEN: ALL APPLICANTS FOR MULTIPLE OCCUPANCY STATUS MUST PRESENT

WITH THEIR DEVELOPMENT APPLICATION A SITE AND DEVELOPMENT PLAN OF EXISTING AND PROPOSED CONDITIONS ON THE HOLDING IN QUESTION.

Note: Development application fees have been raised as an issue of concern to both New Settlers and Council Officers. It is open to the Council to determine under section 167 of the Local Government Act the appropriate level of development application fees for multiple occupancy holdings. Provisions relating to development application fees are also included in the Environmental Planning and Assessment Act.

POLICY FOURTEEN: THE ISSUE OF RATING MULTIPLE OCCUPANCY HOLDINGS IS A LOCAL MATTER AND SHOULD BE DEALT WITH AT THE LOCAL LEVEL.

Note: The provisions of section 118 of the Local Government Act already confer a wide discretion upon councils in the determination of their rating policies for rural lands. With the flexibility possible under that section in respect of the general rate and the various forms of differential general rates, most councils should find it possible to accommodate their policies.

IMPLEMENTATION

5. The policy requirements are designed to ensure that only bona fide multiple occupancy holdings are approved.

6. It is proposed that the policy be implemented by way of an enabling clause in planning instruments. Preparation and gazettal of an enabling clause would be carried out by the Planning and Environment Commission at the request of the Council concerned.

7. The enabling clause procedure has been selected because of the dispersed nature of multiple occupancy cases, both in a Statewide and local government context, and its general ease of administration. The enabling clause will, however, empower Councils to exercise sufficient control over applications.

8. Councils will be able to take into account specific local conditions, particularly environmental and locational matters, and request that these conditions be considered by the N.S.W. Planning and Environment Commission in the preparation of a locally appropriate enabling clause.

9. If implementation is to take place under the Environmental Planning and Assessment Act, 1979, it could be effected either by a Council taking action to amend its planning instrument by way of the local planning process, or by the Department of Environment and Planning taking similar action under the State planning policy process.

MONITORING OF THE POLICY

10. In order to assess the workings of the policy over the next few years, the Commission would appreciate receiving brief details of all multiple occupancy applications, whether approved or not. These should be sent to the regional offices of the Planning and Environment Commission.

FURTHER INFORMATION

11. Should you require further advice on the policy please contact the Regional Manager concerned:

Northern, Mr. Rod Nichols, Grafton (066) 42 0622.

Hunter, Mr. Ken Short, Newcastle (049) 2 3818.

Gosford/Wyong, Mr. David Kettle, Gosford (043) 24 7766.

Illawarra, Mr. Percy Wyles, Wollongong (042) 28 4644.

South-East, Mr. Ted Schultheis, Queanbeyan, (062) 97 6911.

Western, Mr. Adrian Boss, Sydney (02) 266 7111.

Sydney Outer Western, Mr. Geoff Goodwin, Sydney (02) 266 7111.

South, Mr. Charles Hill, Sydney (02) 597 1233.

Yours faithfully,

R.L. PINCINI
SECRETARY
3rd July, 1980

APPENDIX 2

Penalties

The Act and the Ordinance provide for the following penalties:

- 1) A penalty of not more than \$10 a day for occupation of "a building which has not been completed in accordance with the approved plans and specifications" every day during which the occupation continues after notice from the Council.
- 2) A penalty of not more than \$100 for the erection of a building in contravention of the Ordinance, and a daily penalty of not more than \$10 for any continuation of the offence.
- 3) Ten dollars for a first offence, \$20 for a second offence and a daily penalty of not more than \$1 a day after being found guilty of an offence under the Ordinance where a penalty is not elsewhere prescribed.
- 4) The same penalty as in (1) above for erecting a tent in contravention of the Ordinance or for failing to comply with any conditions attached to the approval for erecting a tent.

APPENDIX 3
Guide Letters to Council

**LETTER TO COUNCIL, SEEKING MOVABLE
DWELLING LICENCE**

(ADDRESS)

The Shire/Town Clerk
Shire/Municipality of ...
(Address)

Date:

Dear Shire/Town Clerk,

I wish to apply for a "movable dwelling licence" to occupy my land at (describe location) from (date).

I intend to (describe intention and reasons, e.g. to erect a tent and live on the property to evaluate site and environmental conditions prior to submitting a building application for a permanent dwelling ...).

I undertake to dispose of household waste and nightsoil and to comply with other Council requirements.

Yours faithfully,

(NAME)

**LETTER TO COUNCIL, SEEKING APPROVAL
FOR OCCUPATION BEFORE COMPLETION**

(ADDRESS)

The Shire/Town Clerk
Shire/Municipality of ...
(Address)

Date:

Dear Shire/Town Clerk,

Re: New house at (location)

Following approval of my Building Application dated, your reference (if any), I now advise that the building has reached a habitable stage and I wish to occupy it prior to practical completion because (state reasons, e.g. nowhere else to live).

In my opinion the building is safe, healthy and weatherproof.

Yours faithfully,

(NAME)

LETTER PROPOSING TO BUILD AN UNUSUAL
OR INNOVATIVE STRUCTURE

(ADDRESS)

The Shire/Town Clerk,
Shire/Municipality of ...
(Address)

Date:

Dear Shire/Town Clerk,

Re: Building Application
Lot ..., (location description)

In support of my building application dated,
I submit the following statement and request for your
further consideration.

I seek to erect a (complex, innovative, unusual, etc.)
dwelling which is illustrated on the accompanying plans.

There is ample precedent for this structure and I enclose
articles/photographs/other evidence for your further information.

Due to the complex nature of the structure, I am unable
to supply structural analysis and calculations. Instead,
I propose that the structural adequacy of the building
be demonstrated on site after completion and before occupation.
I believe that the complete structure with dead loads
imposed, demonstrated live loading where applicable, and
simulated wind loading should be adequate proof of structural
safety. (I attach details of loading simulations.)* Under
these circumstances, I undertake full responsibility for
any failure of the structure and for the costs of any
tests.

I understand that Council may grant conditional approval
for such structures under Part 43.1(1) of Ordinance 70
and now seek conditional approval for this application.

Yours faithfully,

(NAME)

* If available.

APPENDIX 4

Plant Material

SHELTER BELTS; WINDBREAKS (UNDER 6m)

Origin: A — Australia
 NZ — New Zealand
 Nature: E — evergreen
 D — deciduous

Species	Origin	Common Name	Nature
<i>Acacia armata</i>	A	Hedge wattle	E
<i>Acacia falciformis</i>	A	Hickory wattle	E
<i>Acacia nowitti</i>	A	Sticky wattle	E
<i>Acacia longifolia</i>	A	Sallow wattle	E
<i>Acacia provissima</i>	A	Orens wattle	E
<i>Acacia salicina</i>	A	Willow wattle	E
<i>Acacia saligna</i>	A	Golden wreath wattle	E
<i>Arisototelia serrata</i>	NZ	N.Z. wine berry	E
<i>Banksia serrata</i>	A	Saw banksia	E
<i>Callitris columellaris</i>	A	White cypress pine	E
<i>Callitris preissii (robusta)</i>	A	Slender cypress pine	E
<i>Callitris rhomboidea</i>	A	Oyster Bay Cypress pine	E
<i>Casuarina glauca</i>	A	Grey bull-oak	E
<i>Casuarina torulosa</i>	A	Rose she-oak	E
<i>Corynocarpus laevigata</i>	NZ	N.Z. laurel	E
<i>Eugenia smithii (Acmena)</i>	A	Lilly-pilly	E
<i>Eugenia australis (myrtifolia)</i>	A	Brush cherry	E
<i>Eugenia luehmanni</i>	A	Small leaf lilly-pilly	E
<i>Eucalyptus cladocalyx 'Nana'</i>	A	Dwarf sugar gum	E
<i>Eucalyptus comuta</i>	A	Yate	E
<i>Eucalyptus luehmanniana</i>	A	Bushy yate	E
<i>Eucalyptus nutans</i>	A	Nodding gum	E
<i>Eucalyptus steedmani</i>	A	Steedman gum	E
<i>Hakea elliptica</i>	A	Oval leaf hakea	E
<i>Hakea saligna</i>	A	Willow hakea	E
<i>Hakea laurina</i>	A	Pincushion hakea	E
<i>Hibiscus filiaceus</i>	A	Cotton tree hibiscus	E
<i>Hoheria populnea</i>	NZ	N.Z. lacebark	E
<i>Leptospermum laevigatum</i>	A	Coast Tea-tree	E
<i>Leptospermum pubescens</i>	A	Silky Tea-tree	E
<i>Lagunaria patersoni</i>	A	Pyramid tree	E
<i>Melaleuca squarrosa</i>	A	Scented paperback	E
<i>Melaleuca nesophila</i>	A	Western tea myrtle	E
<i>Melaleuca pubescens</i>	A	Moonah	E
<i>Macadamia ternifolia</i>	A	Queensland nut	E
<i>Myrsine orvillei</i>	NZ	Red matipo	E
<i>Myrtus bullata</i>	NZ	Ramarama	E
<i>Metrosideros excelsa (Tomentosa)</i>	NZ	N.Z. Christmas tree	E
<i>Myporum insulare</i>	A	Boobiella	E
<i>Olearia paniculata</i>	NZ	Golden ake-ake	E
<i>Pittosporum rhombifolium</i>	A	Queensland pittosporum	E
<i>Pittosporum undulatum</i>	A	Sweet pittosporum	E
<i>Pittosporum crassifolium</i>	NZ	Karo	E
<i>Pittosporum tenuifolium</i>	NZ	Kohuhu	E
<i>Tristania laurina</i>	A	Kanuka or water gum	E

SHELTER BELTS & WIND BREAKS (6m AND OVER)

<i>Acacia dealbata</i>	A	Silver wattle	E
<i>Acacia terminalis (elata)</i>	A	Cedar wattle	E
<i>Acacia mearinsi (mollissima)</i>	A	Black wattle	E
<i>Acacia melanoxylon</i>	A	Blackwood	E
<i>Acacia decurrens</i>	A	Queena black wattle	E
<i>Callitris preissii (robusta)</i>	A	Slender cypress pine	E

<i>Callitris columellaris (glauca)</i>	A	White cypress pine	E
<i>Callitris endlicheri (calcarata)</i>	A	Black cypress pine	E
<i>Casuarina glauca</i>	A	Grey bull-oak	E
<i>Casuarina luehmanni</i>	A	Bull-oak	E
<i>Eucalyptus botryoides</i>	A	Mahogany gum	E
<i>Eucalyptus globulus</i>	A	Tasmanian blue gum	E
<i>Eucalyptus gomphocephala</i>	A	Tuart	E
<i>Eucalyptus racemosa</i>	A	Narrow leaf ironbark	E
<i>Ficus lacor</i>	A	Cunningham fig	E
<i>Melaleuca styphelioides</i>	A	Prickly paperbark	E
<i>Tristania conferta</i>	A	Brush box	E

FAST GROWING DECIDUOUS VINES

<i>Actinidia chinensis</i>	Chinese gooseberry (Kiwi fruit)
<i>Campsis grandiflora</i>	Chinese trumpet-creeper
<i>Campsis 'Madam-Galen'</i>	
<i>Louicera caprifolium</i>	Sweet woodbine
<i>Mandevilla laxa (suav)</i>	Chile-jasmine
<i>Parthenocissus quinquefolia</i>	Virginia creeper
<i>Parthenocissus tricuspidata</i>	
<i>Vitis spp.</i>	Grape
<i>Wistaria floribunda</i>	Long cluster wistaria
<i>Wistaria sinensis</i>	Chinese wistaria
<i>Wistaria venusta</i>	

SELF-CLINGING CLIMBERS FOR STONE & BRICK SURFACES

<i>Bignonia capreolata</i>	Cross vine
<i>Dexantha unguis-cati</i>	Cat's claw creeper
<i>Euonymus fortunei 'Reticulata'</i>	Vined spindle creeper
<i>Ficus pumila</i>	Climbing fig
<i>Ficus pumila 'Minima'</i>	Dwarf climbing fig
<i>Hedera helix</i>	English ivy
<i>Hedera corymbosa</i>	Ivy (variegated)
<i>Metrosideros diffusa</i>	Small Rata vine
<i>Parthenocissus quinquefolia</i>	Virginia creeper
<i>Parthenocissus tricuspidata</i>	Virginia creeper
<i>Phaedranthus buccinatorius</i>	Mexican blood-trumpet

EDIBLE FRUIT CLIMBERS

<i>Actinidia chinensis</i>	E	Chinese gooseberry or Kiwi fruit
<i>Monstera deliciosa</i>	E	Fruit salad plant
<i>Passiflora edulis</i>	E	Purple passion fruit
<i>Passiflora mollissima</i>	E	Banana passion fruit
<i>Passiflora quadrangularis</i>	E	Giant granadilla

DROUGHT RESISTANT CLIMBERS

<i>Bougainvillea 'Magnifica'</i>	Purple bougainvillea
<i>Bougainvillea spp.</i>	
<i>Clematis microphylla</i>	
<i>Hardenbergia violacea</i>	Purple coral pea
<i>Jasminum mesnyi</i>	Primrose jasmine
<i>Kennedia nigricans</i>	Black coral pea
<i>Kennedia rubicunda</i>	Dusky coral pea
<i>Lonicera japonica</i>	Honeysuckle
<i>Muehlenbeckia complexa</i>	Maidenhair creeper
<i>Pandorea pandorana</i>	Wonga-vine
<i>Pandorea jasminoides</i>	Bower of Beauty
<i>Pandorea ricasoliana</i>	Pink tecoma

TREES FOR OVER-WET SITES
— NATIVE SPECIES

<i>Acacia decurrens</i>	Black wattle
<i>Acacia floribunda</i>	White sallow wattle
<i>Acacia longifolia</i>	Sydney golden wattle
<i>Angophora costata</i>	Smooth-barked apple
<i>Angophora intermedia</i>	Rough-barked apple (fast growing)
<i>Callicoma serratifolia</i>	Black wattle
<i>Callistemon paludosus</i>	Swamp bottle brush
<i>Callistemon pinifolius</i>	Green-flowering bottle brush
<i>Callistemon rugulosus</i>	
<i>Callistemon salignus</i>	White bottle brush
<i>Callistemon viminalis</i>	Drooping bottle brush
<i>Castanospermum australe</i>	Black bean
<i>Casuarina cunninghamiana</i>	River she-oak
<i>Casuarina glauca</i>	Swamp oak
<i>Eucalyptus botryoides</i>	Bangalay or southern mahogany
<i>Eucalyptus camaldulensis</i>	River red gum
<i>Eucalyptus deanei</i>	Round-leaved gum
<i>Eucalyptus globulus</i>	Tasmanian blue gum
<i>Eucalyptus grandis</i>	Flooded gum
<i>Eucalyptus oreades</i>	Blue Mountains ash
<i>Eucalyptus robusta</i>	Swamp mahogany
<i>Eucalyptus saligna</i>	Sydney blue gum
<i>Hymenosporum flavum</i>	Native frangipanni
<i>Melaleuca quinquenervia</i>	Broad-leaved paperbark
<i>Melaleuca styphelioides</i>	Prickly-leaved paperbark
<i>Melia azedarach</i>	White cedar
<i>Tristania laurina</i>	Water gum

APPENDIX 5.

Selection of Timber Species

Timber	Durability class*	Lyctus susceptibility**	Stress grade***
Grey ironbark <i>E. paniculata</i>	1	R.S.	F27
Turpentine <i>Syncarpia glomulifera</i>	1	N.S.	F17
White mahogany <i>E. acmenoides</i>	1	N.S.	F22
White cypress pine <i>Callitris columellaris</i>	1	N.S.	F4
Grey gum <i>E. propinqua, E. punctata</i>	1	N.S.	F22
Red ironbark <i>E. sideroxylon</i>	1	R.S.	F22
Red or broadleaved ironbark <i>E. fibrosa</i>	1	R.S.	F22
Narrowleaved red ironbark <i>E. crebra</i>	1	N.S.	F22
Tallowwood <i>E. microcorys</i>	1	S	F22
Red bloodwood <i>E. gummifera</i>	1	S	F17
Grey box <i>E. moluccana</i>	1	R.S.	F22
Yellow box <i>E. melliodora</i>	1	N.S.	F17
Yellow stringybark <i>E. muellerana</i>	2	N.S.	F17
River red gum <i>E. camaldulensis</i>	2	S.	F11
Forest red gum <i>E. tereticornis</i>	2	S.	F17
Red mahogany <i>E. resinifera</i>	2	S.	F22
Blackbutt <i>E. pilularis</i>	2-3	N.S.	F22
Spotted gum <i>E. maculata</i>	2-3	S.	F22
New England blackbutt <i>E. andrewsii</i> <i>E. campanulata</i>	2-3	S.	F17
White stringy bark <i>E. eugenoides</i>	2-3	N.S.	F17
Silvertop stringy bark <i>E. laevopinea</i>	2-3	R.S.	F14
Flooded gum (Rose gum) <i>E. grandis</i>	3	N.S.	F17
Sydney blue gum <i>E. saligna</i>	3	S.	F17
Woollybutt <i>E. longifolia</i>	3	S.	F17
Brown stringybark <i>E. capitellata</i>	3	N.S.	F14
Messmate stringybark <i>E. obliqua</i>	3	S.	F17

Brushbox <i>Tristania conferta</i>	33	R.	F17
Silvertop ash <i>E. sieberi</i>	4	S.	F17
Brown barrel <i>E. fastigata</i>	4	S.	F14
Radiata pine <i>Pinus radiata</i>	4	N.S.	F5 (seasoned)
Oregon (Douglas fir)	4	N.S.	F5
<i>Pseudotsuga menziesii</i>	4	N.S.	F5

*Durability Class means resistance of the heartwood to attack by fungi and insects —

Class 1 gives 25-50 years service in the ground

Class 2 gives 15-25 years service in the ground

Class 3 gives 8-15 years service in the ground

Class 4 should not be used in the ground.

**Lyctus Susceptibility

N.S. — not susceptible

R.S. — rarely susceptible

S. — susceptible

***The Standards Association of Australia grades timber according to the stresses which it is able to sustain. These gradings are given as 'F' values and range from F37 (the strongest) to F4.

TERMITE RESISTANCE

This means the ability of the heartwood to resist termite attack. Generally, the class 1 durability timbers i.e. the denser eucalypt timbers, turpentine, and white cypress pine show considerable resistance to termite attack, unlike most of the lightweight, light-coloured hardwoods which do not. This resistance may vary according to locality and so local experience will be invaluable in determining suitable species.

Homebuilders should take care in the identification of timber species. Local knowledge may be most helpful, or the following publications can be consulted.

"Forest Trees of Australia" — Australian Govt. Publishing Service (out of print)

"Commercial Timbers of N.S.W. and their Use" — K. R. Bootle

"A Field Guide to Australian Trees" — Ivan Holliday, Ron Hill — Rigby

"Australian Native Plants" — John Wrigley, Murray Fagg — Collins

Leaflets available from University of New England
Dept. of Continuing Education, North Coast Regional
Office, P.O. Box 200, Coffs Harbour Jetty, N.S.W.

APPENDIX 6

Chemical Preservation of Timber

Home treatments will only treat sapwood (but not cypress pine which is untreatable). There are no treatments for heartwoods of most high durability species.

The following situations arise where preservative treatment of sapwood is necessary:

- 1) Where lyctus-susceptible sapwood is to be used in any part of the building and the owner wishes to include it in the structural calculations;
- 2) Where sapwood of any species is used in structural calculations and there is risk of termite attack or fungal decay; and
- 3) where sapwood is used in external cladding.

Where an existing building has already begun to deteriorate the only effective treatment is to replace the affected member.

The following chemicals may be used in home treatments for the preservation of sapwood.

Chemical	Advantages	Disadvantages
Creosote	Effective fungicide. Toxic to insects if applied by hot/cold treatment.	Toxicity Colour Oily finish Strong odour
Copper chrome arsenic salts (C.C.A. salts)	Effective fungicide, insecticide and preservative. No leaching.	High toxicity, irritates skin, eyes Disposal problem Copper colouring
Boron salts (water soluble)	Effective fungicide, insecticide and preservative if properly impregnated. No colour. Suitable for cold treatment.	Toxic. Liable to leaching
Naphthanates of copper, zinc	Soluble in kerosene, mineral turpentine, solvent naphtha.	Accumulative poison Copper colouring

Note: Sump oil is generally regarded as useless in providing any kind of protection.

Note: Penta-chloro-phenol is omitted from list as its toxicity makes it unsuitable for home use.

CAUTION: Hot treatment with creosote presents a fire hazard. Any moisture is likely to make creosote foam and boil over.

Total immersion in cold creosote to soak for 10 days or so would appear to be a more reasonable home treatment.

CAUTION: The usual recommendation for the disposal of C.C.A. treated timber is that it be buried or burnt in small quantities in the open.

C.C.A. treated timber should never be burnt in a domestic fireplace or stove. Timber treated with these salts can usually be distinguished by its green colouring.

The following treatment techniques may be used for sapwood:

a) Surface application by brush to maintain weathering surface in cladding to exposed sapwood using creosote or proprietary timber finishes.

b) Dip diffusion is a process suited to the use of boron salts. Newly felled and de-barked timber is dipped for a few seconds or surface treated over a plastic sheet in a 20 per cent solution of boron salts. It is then block stacked inside sealed plastic sheeting to prevent drying while the preservative diffuses into the sapwood.

Timber treated in this way cannot be used in the ground and is suitable only for dry use.

Poles up to 150 mm diameter take two weeks, 150 to 200 mm diameter poles need two treatments spaced a week apart, and larger poles may need more treatments for the diffusion to be effective.

c) Sap replacement. This treatment can be used with C.C.A. salts in a 4 per cent solution in water. The solution is drawn up through the sapwood of freshly cut and de-barked hardwood provided the sapwood band is at least 12 mm thick. Best results are obtained when dry, sunny conditions prevail; the poles should be turned daily and the changes in levels of preservative should be noted and topped up as necessary. Three-metre poles should take about seven days.

Protective clothing must be worn when handling C.C.A. salts — any solution on the skin or eyes should be thoroughly washed off immediately.

The solution can be stored indefinitely or disposed of by soaking into other timber which should never be burnt, but buried far from any edible vegetation or water course.

TREATMENT FOR A 3 METRE LENGTH POLE:

Pole diameter	100	125	150	175	200	millimetres
C.C.A. salts	.45	.75	.9	1.35	2.1	kilograms

d) Cold soaking in Creosote. Seasoned posts can be fully immersed in the preservative for about 10 days. Test by cutting a sample post and observing the degree of penetration.

Treatment of most of, if not all, the sapwood layer would be considered satisfactory.

APPENDIX 7 Knee Braced Frames – Round Timber Poles

A knee braced frame has been arranged in the following manner:

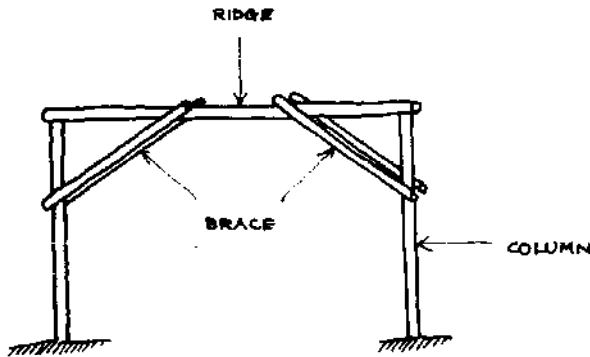

The tables provide diameters of columns, diameters of ridges, diameters of braces and bolt diameters required for a range of knee braced frames.

The following is the layout of the tables:

FRAME TYPE NUMBERS			TABLE NUMBER		TIMBER STRENGTH		
Height	Span	Spacing	Col Diam	Ridge Diam	Brace Diam	Bolt 1	Bolt 2

THE FRAMES ARE SYMMETRICAL

NOTE: Each frame has FOUR poles acting as braces. Each brace number consists of two poles. The brace poles are placed opposite one another.

The spacing is the distance between parallel frames:

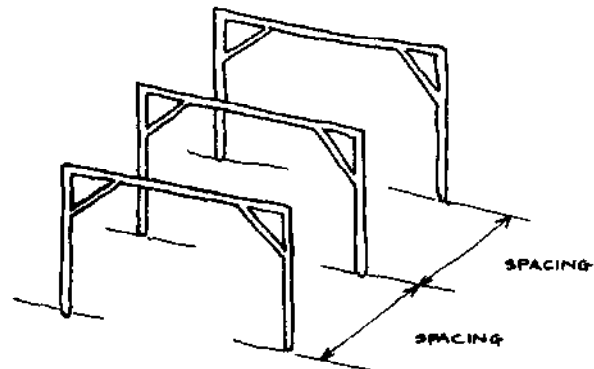

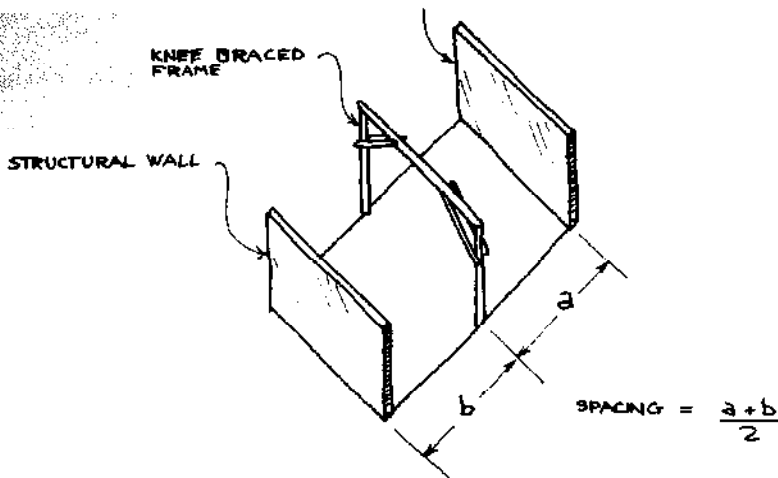

Where one frame only is used the spacing is defined by the above diagram:

There are 24 tables, two for combinations which are not recommended.

The tables cover four timber strengths and six frame types, accounting for the 24 tables.

Timber Species defines timber strengths. For each timber strength there are six tables corresponding to the six frame types. Frame types define the detail geometry once the height and span are chosen. The height and span are usually defined by the building arrangement. The heights range from 3.0 m to 4.8 m in steps of 0.6 m. The spans range from 4.2 m to 6.0 m in steps of 0.6 m. The spacings range from 3.0 m to 4.2 m in steps of 0.6 m.

The steps in reading the tables are:

- 1) Choose timber species.
- 2) From list given under timber strength below obtain the F rating (F11, F14, F17, or F22).
- 3) From list given under Frame Type Number below choose a FRAME TYPE.
- 4) Choose the particular table number:

FRAME TYPE	1	F11	F14	F12	F22	Table numbers
	1	1	7	13	19	
	2	2	8	14	20	
	3	3	9	15	21	
	4	4	10	16	22	
	5	5	11	17	23	
	6	6	12	18	24	

5) From the geometry of the building define the height of the frame.

6) From the geometry of the building define the span of the frame.

7) From the geometry of the building define the spacing of the frames.

8) Now read off:

diameter of the columns

diameter of the ridge

diameter of each of the four members to be used as brace poles (all the brace poles have the same diameter)

diameter of the bolt connecting the braces

diameter of the bolt connecting the column and ridge

9) If in going through the process you have changed your mind about a particular dimension or species go back to the step where that dimension or species was introduced. Designing buildings involves the constant refining of one's ideas.

Frame Type Number

The frame type numbers give the position of the brace once the height and span have been chosen. Each table has a frame type number. There are six frame types numbered 1 to 6. All frames are symmetrical. The following is the definition of each frame type:

FRAME TYPE 1

Tables 1, 7, 13, 19

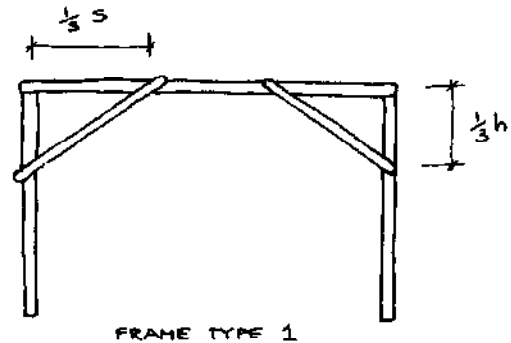

FRAME TYPE 2

Tables 2, 8, 14, 20

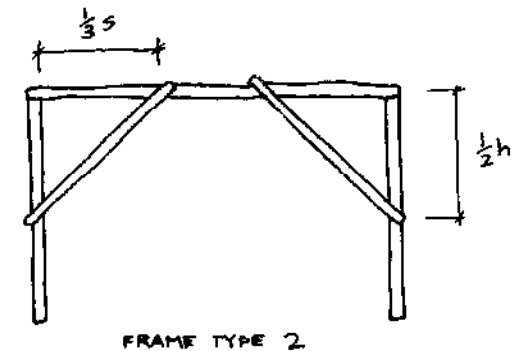

FRAME TYPE 3

Tables 3, 9, 15, 21

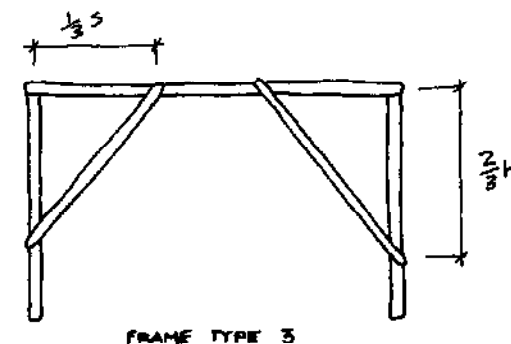

FRAME TYPE 4
Tables 4, 10, 16,
22

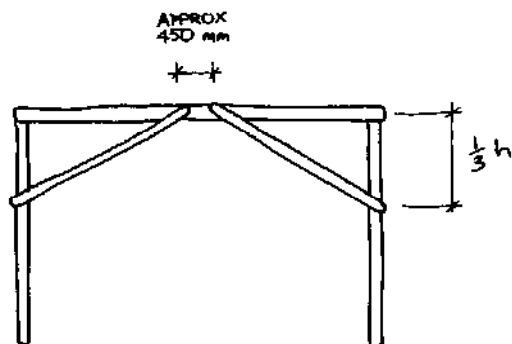

FRAME TYPE 4

FRAME TYPE 5
Tables 5, 11, 17,
23

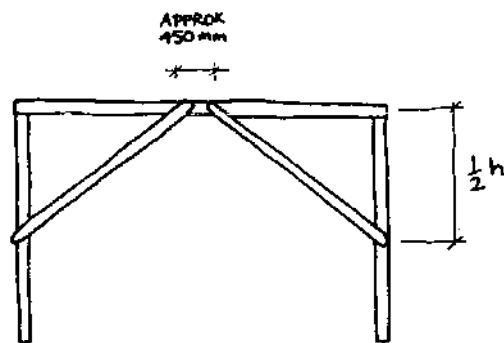

FRAME TYPE 5

FRAME TYPE 6
Tables 6, 12, 18,
24

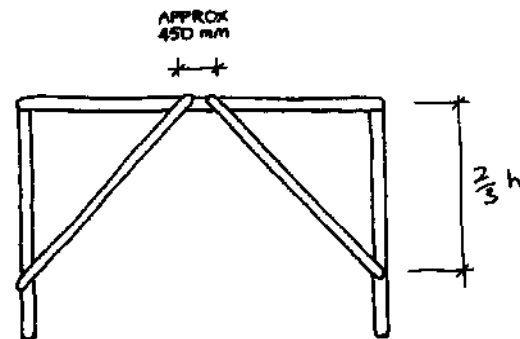

FRAME TYPE 6

S = SPAN h = HEIGHT OF COLUMN

Timber Strength

The timber strength influences two items — the diameter of members and bolt sizes. There are four timber strengths nominated by the titles F11, F14, F17, F22. F11 is the weakest timber and F22 is the strongest timber. For each timber strength there are six tables:

- F11 Tables 1, 2, 3, 4, 5 and 6
- F14 Tables 7, 8, 9, 10, 11 and 12
- F17 Tables 13, 14, 15, 16, 17 and 18
- F22 Tables 19, 20, 21, 22, 23 and 24

(The Timber Engineering Code treats timber strength as it affects member diameters quite differently from timber strength as it affects bolt diameters. For the purposes of these tables the F rating of particular timbers takes account of both aspects of timber strength.)

The timber strength is chosen when the species of wood to be used is identified. The following list gives the F rating to be used with each particular species:

Grey ironbark	F22
Turpentine	F22
White Mahogany	F22
White Cypress Pine	F11
Grey Gum	F22
Red Ironbark	F22
Narrow leaved Red Iron Bark	F22
Tallow wood	F22
Red Bloodwood	F22
Grey Box	F22
Yellow Box	F22
Yellow Stringybark	F22
River Red Gum	F14
Red Mahogany	F22
Blackbutt	F22
Spotted Gum	F22
White Stringy Bark	F22
Flooded Gum (Rose Gum)	F17
Sydney Blue Gum	F22
Woolly Butt	F22
Brown Stringy Bark	F17
Messmate	F17
Brush box	F22
Silvertop Ash	F22
Brown Barrel	F17
Radata Pine	F11*
Oregon (Douglas Fir)	F11
Unidentified Hardwoods	F17

* Preliminary recommendation

Height

The height is the length of the column above the support:

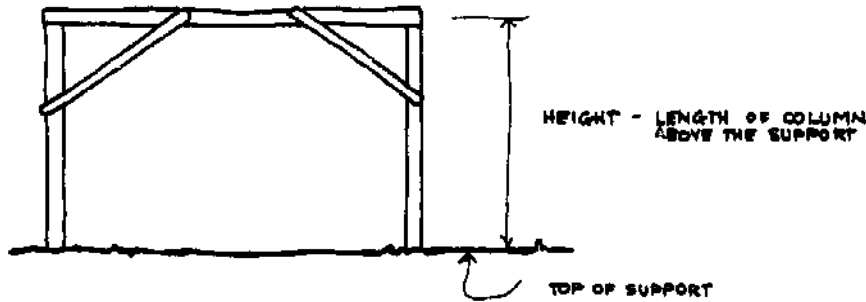

Support

Supports are usually separated into two types — fixed and pinned. For all tables the pinned support condition is assumed.

Example of pinned support:

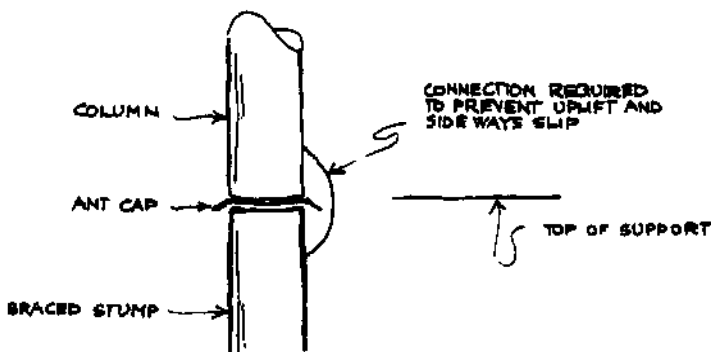

If a fixed support is chosen then the tables can be used just as if the support was pinned — the building is stronger than would normally be required.

NOTE.

All supports must be provided with a connection to the ground sufficient to prevent uplift of the building. Uplift of the building is often the most critical case.

Span

The span is the length defined in the following diagram:

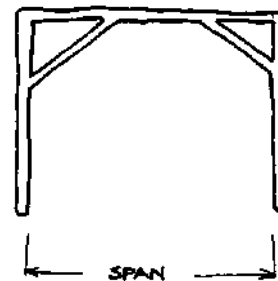

Example of fixed support:

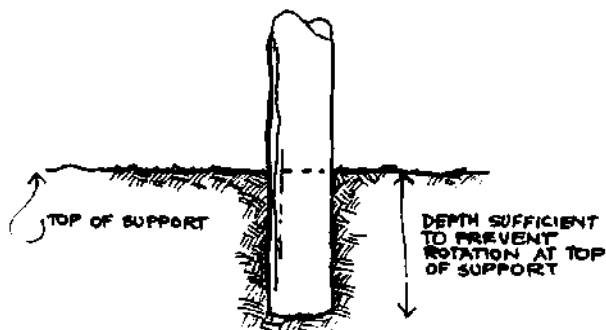

Column, Ridge and Brace Diameters.

Column, ridge and brace diameters are measured mid length. Where the column is not a perfect circle the diameter is measured in the vertical direction in the plane of the frame. Where the brace is not a perfect circle the diameter is the least diameter of the brace.

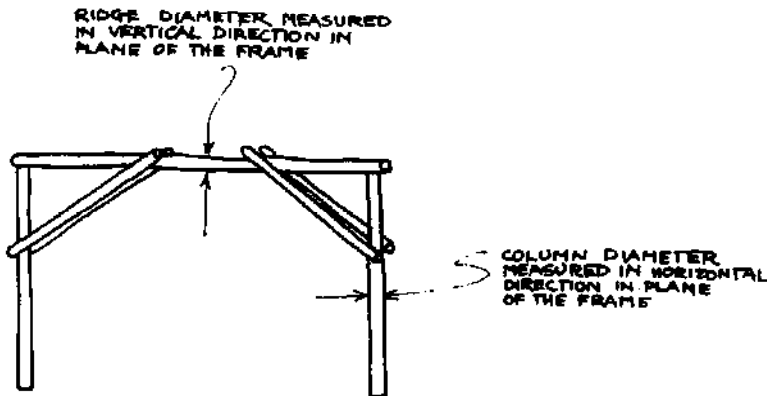

Where the ridge is not a perfect circle the diameter is measured in the vertical direction in the plane of the frame. Where the brace is not a perfect circle the diameter is the least diameter of the brace.

Bolts

Two bolt types are used and nominated as BOLT 1 and BOLT 2. BOLT 1 occurs in 4 positions on a frame and is the bolt used in connecting the brace. BOLT 2 occurs in 2 positions on a frame and is used to connect the columns to the ridge. All bolts are mild steel.

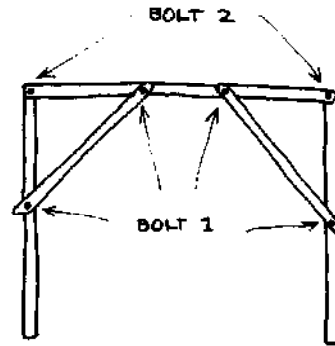

NOTE: When buying bolts note that they are quite long! Binding the ends of members to prevent splitting is recommended.

Brace

Each frame has FOUR pieces of timber acting as braces:

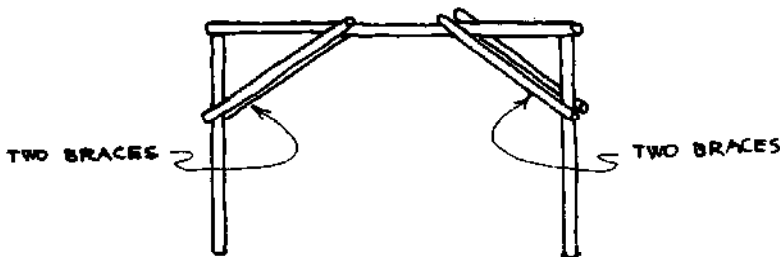

Therefore all bolts nominated BOLT 1 must be long enough to go through two brace diameters plus the diameter of the column ridge.

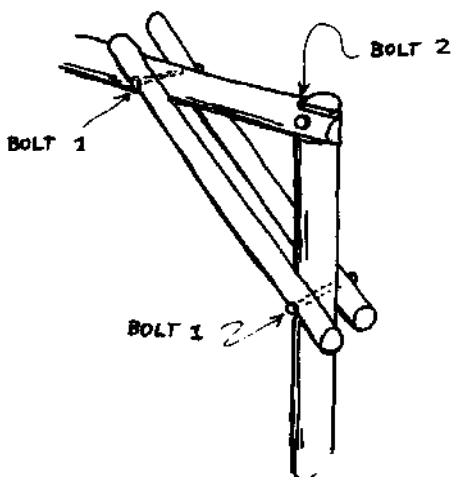

Deflection of Structures under Windload

The deflections of the recommended frames sideways under windload are large by conventional standards. These large side sways have been accepted for the following reasons:

- 1) Most buildings constructed from round poles will not have delicate or brittle finishes which will damage easily due to movement. The frames detailed in the tables are not recommended for such structures.
- 2) By the very nature of the material, high tensile strength combined with low modulus of elasticity, timber must deflect a significant amount in order to activate stress levels.

TABLE No. 1

FRAME TYPE No. 1				TIMBER STRENGTH: F11			
HEIGHT (m)	SPAN (m)	SPACING (m)	COL DIA (mm)	RIDGE DIA (mm)	BRACE DIA (mm)	BOLT1 (mm)	BOLT2 (mm)
FRAMES OF THIS TYPE IN THIS TIMBER STRENGTH ARE NOT RECOMMENDED DUE TO THE LARGE BOLT SIZES REQUIRED							

TABLE No. 2

FRAME TYPE No. 2				TIMBER STRENGTH: F11				
HEIGHT (m)	SPAN (m)	SPACING (m)	COL DIA (mm)	RIDGE DIA (mm)	BRACE DIA (mm)	BOLT1 (mm)	BOLT2 (mm)	
3.0	4.2	3.0	145	115	75	16	16	
		3.6	155	135	80	20	20	
		4.2	160	140	80	20	20	
	4.8	3.0	3.6	155	115	75	16	16
			3.6	160	135	80	20	20
			4.2	170	140	80	20	20
	5.4	3.0	3.6	160	130	80	20	20
			3.6	170	135	80	20	20
			4.2	175	155	80	20	20
	6.0	3.0	3.6	165	130	80	20	20
			3.6	175	135	80	20	20
			4.2	185	155	95	24	24
3.6	4.2	3.0	155	135	80	20	20	
		3.6	165	140	80	20	20	
		4.2	175	150	80	20	20	
	4.8	3.0	3.6	160	135	80	20	20
			3.6	170	140	80	20	20
			4.2	180	150	80	20	20
	5.4	3.0	3.6	170	135	80	20	20
			3.6	180	140	80	20	20
			4.2	185	160	80	20	20
	6.0	3.0	3.6	175	135	80	20	20
			3.6	185	140	80	20	20
			4.2	195	160	95	24	24
4.2	4.2	3.0	165	140	80	20	20	
		3.6	175	165	95	24	24	
		4.2	185	170	95	24	24	
	4.8	3.0	3.6	170	140	80	20	20
			3.6	180	155	80	20	20
			4.2	190	170	95	24	24
	5.4	3.0	3.6	175	140	80	20	20
			3.6	190	150	80	20	20
			4.2	195	165	95	24	24
	6.0	3.0	3.6	185	140	80	20	20
			3.6	195	160	80	20	20
			4.2	205	165	95	24	24
4.8	4.2	3.0	175	160	95	24	24	
		3.6	185	170	95	24	24	
		4.2		Not recommended, use closer spacing				
	4.8	3.0	3.6	180	150	80	20	20
			3.6	190	170	95	24	24
			4.2		Not recommended, use closer spacing			
	5.4	3.0	3.6	185	145	80	20	20
			3.6	195	165	95	24	24
			4.2		Not recommended, use closer spacing			
	6.0	3.0	3.6	190	145	80	20	20
			3.6	205	165	95	24	24
			4.2		Not recommended, use closer spacing			

TABLE No. 3

FRAME TYPE No. 3			TIMBER STRENGTH: F11					
HEIGHT (m)	SPAN (m)	SPACING (m)	COL DIA (mm)	RIDGE DIA (mm)	BRACE DIA (mm)	BOLT1 (mm)	BOLT2 (mm)	
3.0	4.2	3.0	130	115	75	16	16	
		3.6	135	135	75	16	16	
		4.2	140	140	80	20	20	
	4.8	3.0	135	115	75	16	16	
			3.6	140	135	80	20	20
			4.2	150	140	80	20	20
	5.4	3.0	140	115	75	16	16	
			3.6	150	135	80	20	20
			4.2	155	140	80	20	20
6.0	3.0	145	125	75	16	16		
		3.6	155	135	80	20	20	
		4.2	165	140	80	20	20	
3.6	4.2	3.0	135	135	75	16	16	
		3.6	145	140	80	20	20	
		4.2	150	150	80	20	20	
	4.8	3.0	140	135	75	16	16	
			3.6	150	140	80	20	20
			4.2	160	150	80	20	20
	5.4	3.0	145	135	80	20	20	
			3.6	155	140	80	20	20
			4.2	165	150	80	20	20
	6.0	3.0	155	135	80	20	20	
			3.6	165	140	80	20	20
			4.2	170	160	95	24	24
	4.2	4.2	3.0	145	140	80	20	20
			3.6	155	160	95	24	24
			4.2	160	170	95	24	24
4.8		3.0	150	140	80	20	20	
			3.6	160	155	80	20	20
			4.2	170	165	95	24	24
5.4		3.0	155	140	80	20	20	
			3.6	165	150	80	20	20
			4.2	175	165	95	24	24
6.0		3.0	160	140	80	20	20	
			3.6	170	150	80	20	20
			4.2	180	165	95	24	24
4.8		4.2	3.0	160	160	95	24	24
			3.6	165	170	95	24	24
			4.2		Not recommended, use closer spacing			
	4.8	3.0	160	150	85	20	20	
			3.6	170	165	95	24	24
			4.2		Not recommended, use closer spacing			
	5.4	3.0	165	145	85	20	20	
			3.6	175	165	95	24	24
			4.2	180	175	95	24	24
	6.0	3.0	170	145	90	20	20	
			3.6	180	165	95	24	24
			4.2	190	170	95	24	24

TABLE No. 4

FRAME TYPE No. 4				TIMBER STRENGTH: F11			
HEIGHT (m)	SPAN (m)	SPACING (m)	COL DIA (mm)	RIDGE DIA (mm)	BRACE DIA (mm)	BOLT1 (mm)	BOLT2 (mm)

FRAMES OF THIS TYPE IN THIS TIMBER STRENGTH ARE NOT RECOMMENDED DUE TO THE LARGE BOLT SIZES REQUIRED

TABLE No. 5

FRAME TYPE No. 5				TIMBER STRENGTH: F11			
HEIGHT (m)	SPAN (m)	SPACING (m)	COL DIA (mm)	RIDGE DIA (mm)	BRACE DIA (mm)	BOLT1 (mm)	BOLT2 (mm)
3.0	4.2	3.0	150	110	75	16	16
		3.6	160	125	75	16	16
		4.2	165	135	80	20	20
	4.8	3.0	155	110	75	16	16
			165	130	80	20	20
			175	135	80	20	20
	5.4	3.0	165	125	80	20	20
			175	130	80	20	20
			185	150	95	24	24
	6.0	3.0	175	130	80	20	20
			185	150	95	24	24
			Not recommended, use closer spacing				
3.6	4.2	3.0	160	110	75	16	16
		3.6	170	130	80	20	20
		4.2	175	135	80	20	20
	4.8	3.0	165	115	75	16	16
			175	130	80	20	20
			185	135	80	20	20
	5.4	3.0	175	125	80	20	20
			185	135	80	20	20
			190	155	95	24	24
	6.0	3.0	185	130	80	20	20
			190	150	95	24	24
			200	155	95	24	24
4.2	4.2	3.0	170	125	80	20	20
		3.6	180	130	80	20	20
		4.2	190	145	80	20	20
	4.8	3.0	175	125	80	20	20
			185	135	80	20	20
			195	140	80	20	20
	5.4	3.0	180	130	80	20	20
			195	135	80	20	20
			200	155	95	24	24
	6.0	3.0	190	130	85	20	20
			200	150	95	24	24
			210	155	95	24	24
4.8	4.2	3.0	180	125	80	20	20
		3.6	190	145	95	24	24
		4.2	200	150	95	24	24
	4.8	3.0	185	130	80	20	20
			195	140	80	20	20
			205	155	95	24	24
	5.4	3.0	190	130	80	20	20
			205	140	80	20	20
			215	155	95	24	24
	6.0	3.0	195	130	85	20	20
			210	150	95	24	24
			220	155	95	24	24

TABLE No. 6

FRAME TYPE No. 6			TIMBER STRENGTH: F11				
HEIGHT (m)	SPAN (m)	SPACING (m)	COL DIA (mm)	RIDGE DIA (mm)	BRACE DIA (mm)	BOLT1 (mm)	BOLT2 (mm)
3.0	4.2	3.0	130	110	75	16	16
		3.6	140	115	75	16	16
		4.2	145	130	75	16	16
	4.8	3.0	140	110	75	16	16
			145	115	75	16	16
			155	135	80	20	20
	5.4	3.0	145	115	75	16	16
			155	130	80	20	20
			160	135	80	20	20
	6.0	3.0	155	120	80	16	16
			160	135	80	20	20
			170	140	80	20	20
3.6	4.2	3.0	140	110	75	16	16
		3.6	150	130	80	20	20
		4.2	155	135	80	20	20
	4.8	3.0	145	110	75	16	16
			155	130	80	20	20
			165	135	80	20	20
	5.4	3.0	150	115	80	16	16
			160	135	80	20	20
			170	140	80	20	20
	6.0	3.0	160	115	85	16	16
			170	135	85	20	20
			175	140	85	20	20
4.2	4.2	3.0	150	125	80	20	20
		3.6	160	130	80	20	20
		4.2	165	145	80	20	20
	4.8	3.0	155	125	85	20	20
			165	130	85	20	20
			170	140	85	20	20
	5.4	3.0	160	130	90	16	16
			170	135	90	20	20
			180	140	90	20	20
	6.0	3.0	165	130	95	16	16
			175	135	95	20	20
			185	140	95	20	20
4.8	4.2	3.0	160	125	90	20	20
		3.6	165	145	95	24	24
		4.2	175	150	95	24	24
	4.8	3.0	165	125	90	20	20
			170	140	90	20	20
			180	150	95	24	24
	5.4	3.0	170	130	95	20	20
			180	135	95	20	20
			185	155	95	24	24
	6.0	3.0	175	130	100	20	20
			185	135	100	20	20
			195	155	100	24	24

TABLE No. 7

FRAME TYPE No. 1			TIMBER STRENGTH: F14					
HEIGHT (m)	SPAN (m)	SPACING (m)	COL DIA (mm)	RIDGE DIA (mm)	BRACE DIA (mm)	BOLT1 (mm)	BOLT2 (mm)	
3.0	4.2	3.0	150	115	75	16	20	
		3.6	155	120	80	16	20	
		4.2	175	135	80	20	24	
	4.8	3.0	160	115	75	16	20	
		3.6	175	135	80	20	24	
		4.2	190	135	80	20	24	
	5.4	3.0	175	130	80	20	20	
		3.6	190	130	80	20	24	
		4.2	Not recommended, use closer spacing					
	6.0	3.0	185	130	80	20	24	
		3.6	Not recommended, use closer spacing					
		4.2	Not recommended, use closer spacing					
3.6	4.2	3.0	155	120	75	16	20	
		3.6	165	125	80	20	20	
		4.2	180	145	80	20	24	
	4.8	3.0	165	120	75	16	20	
		3.6	175	140	80	20	24	
		4.2	190	140	80	20	24	
	5.4	3.0	175	120	80	20	20	
		3.6	185	135	80	20	24	
		4.2	Not recommended, use closer spacing					
	6.0	3.0	185	130	80	20	24	
		3.6	210	155	95	24	24	
		4.2	Not recommended, use closer spacing					
4.2	4.2	3.0	170	125	75	16	20	
		3.6	180	130	80	20	20	
		4.2	185	150	80	20	24	
	4.8	3.0	175	125	80	20	20	
		3.6	185	145	80	20	24	
		4.2	195	150	80	20	24	
	5.4	3.0	180	125	80	20	20	
		3.6	190	140	80	20	24	
		4.2	Not recommended, use closer spacing					
	6.0	3.0	195	135	80	20	24	
		3.6	210	145	95	24	24	
		4.2	Not recommended, use closer spacing					
4.8	4.2	3.0	180	135	80	20	20	
		3.6	190	150	80	20	24	
		4.2	200	160	95	24	24	
	4.8	3.0	185	135	80	20	20	
		3.6	195	150	80	20	24	
		4.2	205	155	95	24	24	
	5.4	3.0	190	140	80	20	24	
		3.6	200	145	80	20	24	
		4.2	Not recommended, use closer spacing					
	6.0	3.0	200	140	80	20	24	
		3.6	210	155	95	24	24	
		4.2	Not recommended, use closer spacing					

TABLE No. 8

FRAME TYPE No. 2			TIMBER STRENGTH: F14				
HEIGHT (m)	SPAN (m)	SPACING (m)	COL DIA (mm)	RIDGE DIA (mm)	BRACE DIA (mm)	BOLT1 (mm)	BOLT2 (mm)
3.0	4.2	3.0	135	100	75	16	16
		3.6	145	105	75	16	16
		4.2	150	110	75	16	16
	4.8	3.0	140	100	75	16	16
		3.6	150	110	75	16	16
		4.2	160	115	75	16	16
	5.4	3.0	150	105	75	16	16
		3.6	160	110	75	16	16
		4.2	165	125	80	20	20
	6.0	3.0	155	105	75	16	16
		3.6	165	120	80	20	20
		4.2	175	125	80	20	20
3.6	4.2	3.0	145	110	75	16	16
		3.6	155	115	75	16	16
		4.2	160	130	80	20	20
	4.8	3.0	150	110	75	16	16
		3.6	160	120	75	16	16
		4.2	165	130	80	20	20
	5.4	3.0	155	115	75	16	16
		3.6	165	120	75	16	16
		4.2	175	130	80	20	20
	6.0	3.0	160	115	75	16	16
		3.6	170	125	80	20	20
		4.2	180	130	80	20	20
4.2	4.2	3.0	155	120	75	16	16
		3.6	165	130	80	20	20
		4.2	170	135	80	20	20
	4.8	3.0	160	120	75	16	16
		3.6	170	130	80	20	20
		4.2	175	135	80	20	20
	5.4	3.0	165	120	75	16	16
		3.6	175	130	80	20	20
		4.2	185	135	80	20	20
	6.0	3.0	170	125	75	16	16
		3.6	180	130	80	20	20
		4.2	190	140	80	20	20
4.8	4.2	3.0	165	130	80	20	20
		3.6	175	140	80	20	20
		4.2	180	160	95	24	24
	4.8	3.0	170	130	80	20	20
		3.6	180	140	80	20	20
		4.2	185	155	95	24	24
	5.4	3.0	175	130	80	20	20
		3.6	185	140	80	20	20
		4.2	195	145	80	20	20
	6.0	3.0	180	135	80	20	20
		3.6	190	140	80	20	20
		4.2	200	150	80	20	20

TABLE No. 9

FRAME TYPE No. 3			TIMBER STRENGTH: F14				
HEIGHT (m)	SPAN (m)	SPACING (m)	COL DIA (mm)	RIDGE DIA (mm)	BRACE DIA (mm)	BOLT1 (mm)	BOLT2 (mm)
3.0	4.2	3.0	120	100	75	16	16
		3.6	125	105	75	16	16
		4.2	130	110	75	16	16
	4.8	3.0	125	100	75	16	16
		3.6	130	110	75	16	16
		4.2	140	115	75	16	16
	5.4	3.0	130	105	75	16	16
		3.6	140	110	75	16	16
		4.2	145	115	75	16	16
6.0	3.0	135	105	75	16	16	
	3.6	145	115	75	16	16	
	4.2	150	120	75	16	16	
3.6	4.2	3.0	125	110	75	16	16
		3.6	135	115	75	16	16
		4.2	140	130	80	20	20
	4.8	3.0	130	110	75	16	16
		3.6	140	120	75	16	16
		4.2	145	130	80	20	20
	5.4	3.0	135	115	75	16	16
		3.6	145	120	75	16	16
		4.2	155	130	80	20	20
	6.0	3.0	140	115	75	16	16
		3.6	150	125	75	16	16
		4.2	160	130	80	20	20
4.2	4.2	3.0	140	120	75	16	16
		3.6	145	130	80	20	20
		4.2	150	135	80	20	20
	4.8	3.0	140	120	75	16	16
		3.6	150	130	80	20	20
		4.2	155	135	80	20	20
	5.4	3.0	145	125	80	16	16
		3.6	155	130	80	20	20
		4.2	160	140	80	20	20
	6.0	3.0	150	125	85	16	16
		3.6	160	135	85	20	20
		4.2	165	140	85	20	20
4.8	4.2	3.0	160	130	85	20	20
		3.6	160	140	85	20	20
		4.2	160	155	95	24	24
	4.8	3.0	160	135	85	20	20
		3.6	160	140	85	20	20
		4.2	165	155	85	20	20
	5.4	3.0	160	135	90	16	16
		3.6	160	140	90	20	20
		4.2	170	150	90	20	20
	6.0	3.0	160	135	90	16	16
		3.6	165	140	90	20	20
		4.2	175	150	90	20	20

TABLE No. 10

FRAME TYPE No. 4			TIMBER STRENGTH: F14				
HEIGHT (m)	SPAN (m)	SPACING (m)	COL DIA (mm)	RIDGE DIA (mm)	BRACE DIA (mm)	BOLT1 (mm)	BOLT2 (mm)
3.0	4.2	3.0	160	110	75	16	20
		3.6	170	115	80	20	20
		4.2	185	130	80	20	24
	4.8	3.0	170	110	80	20	20
		3.6	185	130	80	20	24
		4.2	210	155	80	20	24
	5.4	3.0	185	125	80	20	24
		3.6	210	150	80	20	24
		4.2	Not recommended, use closer spacing				
	6.0	3.0	210	130	80	20	24
		3.6	Not recommended, use closer spacing				
		4.2	Not recommended, use closer spacing				
3.6	4.2	3.0	165	110	75	16	20
		3.6	175	115	80	20	20
		4.2	185	135	80	20	24
	4.8	3.0	180	110	80	20	20
		3.6	190	130	80	20	24
		4.2	210	140	80	20	24
	5.4	3.0	190	130	80	20	24
		3.6	210	130	80	20	24
		4.2	Not recommended, use closer spacing				
	6.0	3.0	205	130	80	20	24
		3.6	Not recommended, use closer spacing				
		4.2	Not recommended, use closer spacing				
4.2	4.2	3.0	175	115	75	16	20
		3.6	180	130	80	20	24
		4.2	190	135	80	20	24
	4.8	3.0	185	115	80	20	20
		3.6	195	130	80	20	24
		4.2	210	150	95	24	24
	5.4	3.0	200	130	80	20	24
		3.6	210	135	80	20	24
		4.2	Not recommended, use closer spacing				
	6.0	3.0	210	130	80	20	24
		3.6	Not recommended, use closer spacing				
		4.2	Not recommended, use closer spacing				
4.8	4.2	3.0	180	115	80	20	20
		3.6	190	135	80	20	24
		4.2	205	135	80	20	24
	4.8	3.0	195	115	80	20	20
		3.6	200	135	80	20	24
		4.2	Not recommended, use closer spacing				
	5.4	3.0	205	130	80	20	24
		3.6	215	135	80	20	24
		4.2	Not recommended, use closer spacing				
	6.0	3.0	220	130	80	20	24
		3.6	Not recommended, use closer spacing				
		4.2	Not recommended, use closer spacing				

TABLE No. 11

FRAME TYPE No. 5			TIMBER STRENGTH: F14				
HEIGHT (m)	SPAN (m)	SPACING (m)	COL DIA (mm)	RIDGE DIA (mm)	BRACE DIA (mm)	BOLT1 (mm)	BOLT2 (mm)
3.0	4.2	3.0	140	95	75	16	16
		3.6	145	100	75	16	16
		4.2	155	105	75	16	16
	4.8	3.0	150	100	75	16	16
		3.6	155	105	75	16	16
		4.2	160	115	75	16	16
	5.4	3.0	160	100	75	16	16
		3.6	165	105	75	16	16
		4.2	175	120	80	20	20
6.0	3.0	170	100	75	16	16	
	3.6	175	120	80	20	20	
	4.2	185	125	80	20	20	
3.6	4.2	3.0	145	100	75	16	16
		3.6	155	100	75	16	16
		4.2	165	105	75	16	16
	4.8	3.0	155	100	75	16	16
		3.6	165	105	75	16	16
		4.2	170	120	80	20	20
	5.4	3.0	165	100	75	16	16
		3.6	175	105	75	16	16
		4.2	180	125	80	20	20
	6.0	3.0	175	105	80	16	16
		3.6	185	120	80	20	20
		4.2	190	125	80	20	20
4.2	4.2	3.0	155	100	75	16	16
		3.6	165	105	75	16	16
		4.2	175	120	80	20	20
	4.8	3.0	165	100	75	16	16
		3.6	175	105	75	16	16
		4.2	180	120	80	20	20
	5.4	3.0	175	100	75	16	16
		3.6	180	105	75	16	16
		4.2	190	125	80	20	20
	6.0	3.0	185	105	85	16	16
		3.6	190	120	85	20	20
		4.2	200	125	85	20	20
4.8	4.2	3.0	165	105	75	16	16
		3.6	175	120	80	20	20
		4.2	185	125	80	20	20
	4.8	3.0	170	100	75	16	16
		3.6	180	120	80	20	20
		4.2	190	125	80	20	20
	5.4	3.0	180	105	85	16	16
		3.6	190	120	85	20	20
		4.2	200	125	85	20	20
	6.0	3.0	190	105	90	16	16
		3.6	200	120	90	20	20
		4.2	205	125	90	20	20

TABLE No. 12

FRAME TYPE No. 6			TIMBER STRENGTH: F14				
HEIGHT (m)	SPAN (m)	SPACING (m)	COL DIA (mm)	RIDGE DIA (mm)	BRACE DIA (mm)	BOLT1 (mm)	BOLT2 (mm)
3.0	4.2	3.0	120	85	75	12	12
		3.6	130	100	75	16	16
		4.2	135	105	75	16	16
	4.8	3.0	130	90	75	12	12
		3.6	135	100	75	16	16
		4.2	145	105	75	16	16
	5.4	3.0	135	100	75	16	16
		3.6	145	105	75	16	16
		4.2	150	110	75	16	16
	6.0	3.0	140	100	85	16	16
		3.6	150	105	85	16	16
		4.2	155	125	85	20	20
3.6	4.2	3.0	130	100	75	16	16
		3.6	135	100	75	16	16
		4.2	145	105	75	16	16
	4.8	3.0	135	100	75	16	16
		3.6	145	105	75	16	16
		4.2	150	110	75	16	16
	5.4	3.0	140	100	85	16	16
		3.6	150	105	85	16	16
		4.2	160	110	85	16	16
	6.0	3.0	145	105	90	16	16
		3.6	155	110	90	16	16
		4.2	165	125	90	16	16
4.2	4.2	3.0	140	100	85	16	16
		3.6	145	105	85	16	16
		4.2	155	120	85	20	20
	4.8	3.0	145	100	85	16	16
		3.6	150	105	85	16	16
		4.2	160	120	85	16	16
	5.4	3.0	150	100	90	16	16
		3.6	155	105	90	16	16
		4.2	165	120	90	16	16
	6.0	3.0	155	105	95	16	16
		3.6	165	110	95	16	16
		4.2	170	125	95	20	20
4.8	4.2	3.0	160	105	90	16	16
		3.6	160	120	90	20	20
		4.2	165	120	90	20	20
	4.8	3.0	160	100	95	16	16
		3.6	160	120	95	16	16
		4.2	170	125	95	20	20
	5.4	3.0	160	105	100	16	16
		3.6	165	115	100	16	16
		4.2	175	125	100	20	20
	6.0	3.0	160	100	100	16	16
		3.6	170	115	100	16	16
		4.2	180	125	100	20	20

TABLE No. 13

FRAME TYPE No. 1			TIMBER STRENGTH: F17					
HEIGHT (m)	SPAN (m)	SPACING (m)	COL DIA (mm)	RIDGE DIA (mm)	BRACE DIA (mm)	BOLT1 (mm)	BOLT2 (mm)	
3.0	4.2	3.0	145	95	75	16	16	
		3.6	150	110	75	16	20	
		4.2	155	110	75	16	20	
	4.8	3.0	3.0	155	95	75	16	16
			3.6	165	110	75	16	20
			4.2	170	110	80	20	20
	5.4	3.0	3.0	165	105	75	16	20
			3.6	175	110	80	20	20
			4.2	180	125	80	20	24
6.0	3.0	3.0	175	105	80	20	20	
		3.6	185	125	80	20	24	
		4.2	195	125	95	24	24	
3.6	4.2	3.0	150	100	75	16	16	
		3.6	155	115	75	16	20	
		4.2	165	120	80	20	20	
	4.8	3.0	3.0	160	105	75	16	16
			3.6	170	110	75	16	20
			4.2	175	115	80	20	20
	5.4	3.0	3.0	170	105	75	16	20
			3.6	180	115	80	20	20
			4.2	185	130	80	20	24
6.0	3.0	3.0	180	110	75	16	20	
		3.6	190	125	80	20	24	
		4.2	200	130	80	20	24	
4.2	4.2	3.0	160	115	75	16	16	
		3.6	170	120	75	16	20	
		4.2	175	125	80	20	20	
	4.8	3.0	3.0	165	115	75	16	16
			3.6	175	120	80	20	20
			4.2	180	125	80	20	20
	5.4	3.0	3.0	180	115	75	16	20
			3.6	185	120	80	20	20
			4.2	195	135	80	20	24
6.0	3.0	3.0	190	115	80	20	20	
		3.6	195	130	80	20	24	
		4.2	205	135	80	20	24	
4.8	4.2	3.0	170	125	75	16	16	
		3.6	180	135	80	20	20	
		4.2	190	140	80	20	20	
	4.8	3.0	3.0	175	125	75	16	20
			3.6	185	130	80	20	20
			4.2	190	145	80	20	24
	5.4	3.0	3.0	185	125	75	16	20
			3.6	190	130	80	20	20
			4.2	200	140	80	20	24
6.0	3.0	3.0	195	125	80	20	20	
		3.6	200	135	80	20	24	
		4.2	210	140	95	24	24	

TABLE No. 14

FRAME TYPE No. 2			TIMBER STRENGTH: F17				
HEIGHT (m)	SPAN (m)	SPACING (m)	COL DIA (mm)	RIDGE DIA (mm)	BRACE DIA (mm)	BOLT1 (mm)	BOLT2 (mm)
3.0	4.2	3.0	125	95	75	12	12
		3.6	135	100	75	16	16
		4.2	140	105	75	16	16
	4.8	3.0	135	95	75	12	12
		3.6	140	100	75	16	16
		4.2	150	105	75	16	16
	5.4	3.0	145	100	75	16	16
		3.6	150	105	75	16	16
		4.2	155	110	75	16	16
	6.0	3.0	150	100	75	16	16
		3.6	160	105	75	16	16
		4.2	165	110	80	20	20
3.6	4.2	3.0	135	105	75	16	16
		3.6	145	110	75	16	16
		4.2	150	115	75	16	16
	4.8	3.0	140	105	75	16	16
		3.6	150	110	75	16	16
		4.2	155	115	75	16	16
	5.4	3.0	150	105	75	16	16
		3.6	155	110	75	16	16
		4.2	165	120	75	16	16
	6.0	3.0	160	110	75	16	16
		3.6	165	115	75	16	16
		4.2	170	120	80	20	20
4.2	4.2	3.0	145	115	75	16	16
		3.6	155	120	75	16	16
		4.2	160	125	80	20	20
	4.8	3.0	150	115	75	16	16
		3.6	160	120	75	16	16
		4.2	165	125	80	20	20
	5.4	3.0	155	115	75	16	16
		3.6	165	120	75	16	16
		4.2	170	130	80	20	20
	6.0	3.0	165	115	75	16	16
		3.6	170	125	75	16	16
		4.2	180	130	80	20	20
4.8	4.2	3.0	160	125	75	16	16
		3.6	165	130	80	20	20
		4.2	170	140	80	20	20
	4.8	3.0	160	125	75	16	16
		3.6	165	130	80	20	20
		4.2	175	135	80	20	20
	5.4	3.0	160	125	75	16	16
		3.6	170	130	80	20	20
		4.2	180	140	80	20	20
	6.0	3.0	170	125	75	16	16
		3.6	175	130	80	20	20
		4.2	185	140	80	20	20

TABLE No. 15

FRAME TYPE No. 3			TIMBER STRENGTH: F17					
HEIGHT (m)	SPAN (m)	SPACING (m)	COL DIA (mm)	RIDGE DIA (mm)	BRACE DIA (mm)	BOLT1 (mm)	BOLT2 (mm)	
3.0	4.2	3.0	110	95	75	12	12	
		3.6	120	100	75	12	12	
		4.2	125	105	75	16	16	
	4.8	3.0	115	95	75	12	12	
		3.6	125	100	75	16	16	
		4.2	130	105	75	16	16	
	5.4	3.0	120	100	75	12	12	
		3.6	130	105	75	16	16	
		4.2	135	110	75	16	16	
	6.0	3.0	130	100	75	12	12	
		3.6	135	105	75	16	16	
		4.2	140	110	75	16	16	
	3.6	4.2	3.0	120	105	75	12	12
			3.6	125	110	75	16	16
			4.2	135	115	75	16	16
4.8		3.0	125	105	75	12	12	
		3.6	130	110	75	16	16	
		4.2	140	120	75	16	16	
5.4		3.0	130	105	75	12	12	
		3.6	135	115	75	16	16	
		4.2	145	120	75	16	16	
6.0		3.0	135	110	75	16	16	
		3.6	140	115	75	16	16	
		4.2	150	120	75	16	16	
4.2		4.2	3.0	140	115	75	16	16
			3.6	140	120	75	16	16
			4.2	140	125	80	20	20
	4.8	3.0	140	115	80	16	16	
		3.6	140	120	80	16	16	
		4.2	145	130	80	16	16	
	5.4	3.0	140	115	85	16	16	
		3.6	145	125	85	16	16	
		4.2	150	130	85	16	16	
	6.0	3.0	140	115	85	16	16	
		3.6	150	125	85	16	16	
		4.2	155	130	85	16	16	
	4.8	4.2	3.0	160	125	85	16	16
			3.6	160	130	85	20	20
			4.2	160	140	85	20	20
4.8		3.0	160	125	90	16	16	
		3.6	160	130	90	16	16	
		4.2	160	140	90	20	20	
5.4		3.0	160	125	90	16	16	
		3.6	160	135	90	16	16	
		4.2	160	140	90	20	20	
6.0		3.0	160	125	95	16	16	
		3.6	160	135	95	16	16	
		4.2	165	140	95	20	20	

TABLE No. 16

FRAME TYPE No. 4			TIMBER STRENGTH: F17				
HEIGHT (m)	SPAN (m)	SPACING (m)	COL DIA (mm)	RIDGE DIA (mm)	BRACE DIA (mm)	BOLT1 (mm)	BOLT2 (mm)
3.0	4.2	3.0	155	85	75	16	16
		3.6	160	105	75	16	20
		4.2	170	105	80	20	20
	4.8	3.0	165	100	75	16	20
		3.6	175	105	80	20	20
		4.2	180	125	80	20	24
	5.4	3.0	180	105	75	16	20
		3.6	185	120	80	20	24
		4.2	195	125	80	20	24
	6.0	3.0	190	120	80	20	24
		3.6	195	120	80	20	24
		4.2	Not recommended, use closer spacing				
3.6	4.2	3.0	160	90	75	16	16
		3.6	170	105	75	16	20
		4.2	175	110	80	20	20
	4.8	3.0	175	105	75	16	20
		3.6	185	105	80	20	20
		4.2	190	125	80	20	24
	5.4	3.0	185	105	75	16	20
		3.6	195	120	80	20	24
		4.2	200	125	80	20	24
	6.0	3.0	195	105	80	20	20
		3.6	205	125	80	20	24
		4.2	Not recommended, use closer spacing				
4.2	4.2	3.0	170	90	75	16	16
		3.6	175	105	75	16	20
		4.2	185	110	80	20	20
	4.8	3.0	180	105	75	16	20
		3.6	190	105	80	20	20
		4.2	195	125	80	20	24
	5.4	3.0	195	105	75	16	20
		3.6	200	120	80	20	24
		4.2	210	125	80	20	24
	6.0	3.0	205	105	80	20	20
		3.6	215	125	80	20	24
		4.2	225	150	95	24	24
4.8	4.2	3.0	175	105	75	16	20
		3.6	180	110	80	20	20
		4.2	190	120	80	20	20
	4.8	3.0	190	105	75	16	20
		3.6	195	110	80	20	20
		4.2	205	125	80	20	24
	5.4	3.0	200	105	75	16	20
		3.6	210	125	80	20	24
		4.2	215	125	80	20	24
	6.0	3.0	210	105	80	20	20
		3.6	220	125	80	20	24
		4.2	Not recommended, use closer spacing				

TABLE No. 17

FRAME TYPE No. 5			TIMBER STRENGTH: F17				
HEIGHT (m)	SPAN (m)	SPACING (m)	COL DIA (mm)	RIDGE DIA (mm)	BRACE DIA (mm)	BOLT1 (mm)	BOLT2 (mm)
3.0	4.2	3.0	135	80	75	12	12
		3.6	140	90	75	16	16
		4.2	145	95	75	16	16
	4.8	3.0	145	85	75	12	12
		3.6	150	90	75	16	16
		4.2	155	95	75	16	16
	5.4	3.0	155	90	75	16	16
		3.6	160	95	75	16	16
		4.2	170	100	75	16	16
6.0	3.0	165	95	75	16	16	
	3.6	170	100	75	16	16	
	4.2	175	110	80	20	20	
3.6	4.2	3.0	140	85	75	12	12
		3.6	145	90	75	16	16
		4.2	155	95	75	16	16
	4.8	3.0	150	85	75	12	12
		3.6	160	95	75	16	16
		4.2	165	95	75	16	16
	5.4	3.0	160	90	75	16	16
		3.6	170	95	75	16	16
		4.2	175	100	75	16	16
	6.0	3.0	170	95	85	16	16
		3.6	180	100	85	16	16
		4.2	185	115	85	20	20
4.2	4.2	3.0	145	90	75	16	16
		3.6	155	95	75	16	16
		4.2	165	100	75	16	16
	4.8	3.0	155	90	75	16	16
		3.6	165	95	75	16	16
		4.2	170	100	75	16	16
	5.4	3.0	170	95	80	16	16
		3.6	175	100	80	16	16
		4.2	180	105	80	16	16
	6.0	3.0	180	100	85	16	16
		3.6	185	105	85	16	16
		4.2	195	115	85	20	20
4.8	4.2	3.0	160	95	75	16	16
		3.6	165	100	75	16	16
		4.2	175	110	80	20	20
	4.8	3.0	165	95	80	16	16
		3.6	170	100	80	16	16
		4.2	180	105	80	16	16
	5.4	3.0	175	95	85	16	16
		3.6	180	105	85	16	16
		4.2	190	115	85	20	20
	6.0	3.0	185	100	90	16	16
		3.6	190	105	90	16	16
		4.2	200	115	90	20	20

TABLE No. 18

FRAME TYPE No. 6			TIMBER STRENGTH: F17				
HEIGHT (m)	SPAN (m)	SPACING (m)	COL DIA (mm)	RIDGE DIA (mm)	BRACE DIA (mm)	BOLT1 (mm)	BOLT2 (mm)
3.0	4.2	3.0	115	80	75	10	10
		3.6	120	85	75	12	12
		4.2	130	95	75	12	12
	4.8	3.0	120	85	75	12	12
		3.6	130	90	75	12	12
		4.2	135	95	75	16	16
	5.4	3.0	125	90	75	12	12
		3.6	135	95	75	16	16
		4.2	140	100	75	16	16
6.0	3.0	135	95	85	12	12	
	3.6	140	100	85	16	16	
	4.2	150	105	85	16	16	
3.6	4.2	3.0	120	85	75	12	12
		3.6	130	90	75	12	12
		4.2	135	95	75	16	16
	4.8	3.0	125	85	80	12	12
		3.6	135	95	80	16	16
		4.2	140	95	80	16	16
	5.4	3.0	135	90	85	12	12
		3.6	140	95	85	16	16
		4.2	150	100	85	16	16
	6.0	3.0	140	95	90	12	12
		3.6	145	100	90	16	16
		4.2	155	105	90	16	16
4.2	4.2	3.0	140	90	85	12	12
		3.6	140	95	85	16	16
		4.2	145	100	85	16	16
	4.8	3.0	140	90	90	12	12
		3.6	140	95	90	16	16
		4.2	150	100	90	16	16
	5.4	3.0	140	95	95	12	12
		3.6	150	100	95	16	16
		4.2	155	105	95	16	16
	6.0	3.0	145	100	100	16	16
		3.6	155	105	100	16	16
		4.2	160	110	100	16	16
4.8	4.2	3.0	160	95	90	16	16
		3.6	160	100	90	16	16
		4.2	160	105	90	16	16
	4.8	3.0	160	95	95	16	16
		3.6	160	100	95	16	16
		4.2	160	105	95	16	16
	5.4	3.0	160	100	100	16	16
		3.6	160	105	100	16	16
		4.2	165	110	100	16	16
	6.0	3.0	160	100	105	16	16
		3.6	160	105	105	16	16
		4.2	170	115	105	16	16

TABLE No. 19

FRAME TYPE No. 1			TIMBER STRENGTH: F22				
HEIGHT (m)	SPAN (m)	SPACING (m)	COL DIA (mm)	RIDGE DIA (mm)	BRACE DIA (mm)	BOLT1 (mm)	BOLT2 (mm)
3.0	4.2	3.0	140	90	75	16	16
		3.6	145	110	75	16	20
		4.2	155	110	75	16	20
	4.8	3.0	150	90	75	16	16
		3.6	160	110	75	16	20
		4.2	165	110	80	20	20
	5.4	3.0	160	105	75	16	20
		3.6	170	110	80	20	20
		4.2	180	125	80	20	24
6.0	3.0	170	105	80	20	20	
	3.6	180	125	80	20	24	
	4.2	195	125	95	24	24	
3.6	4.2	3.0	145	95	75	16	16
		3.6	155	115	75	16	20
		4.2	160	120	80	20	20
	4.8	3.0	155	95	75	16	16
		3.6	165	110	75	16	20
		4.2	170	115	80	20	20
	5.4	3.0	165	110	75	16	20
		3.6	175	110	80	20	20
		4.2	180	130	80	20	24
	6.0	3.0	175	110	75	16	20
		3.6	185	125	80	20	24
		4.2	190	130	80	20	24
4.2	4.2	3.0	150	105	75	16	16
		3.6	155	120	75	16	20
		4.2	160	125	80	20	20
	4.8	3.0	160	110	75	16	16
		3.6	170	120	80	20	20
		4.2	175	125	80	20	20
	5.4	3.0	175	110	75	16	20
		3.6	180	115	80	20	20
		4.2	185	135	80	20	24
	6.0	3.0	185	110	80	20	20
		3.6	190	130	80	20	24
		4.2	200	135	80	20	24
4.8	4.2	3.0	160	115	75	16	16
		3.6	165	130	80	20	20
		4.2	170	135	80	20	20
	4.8	3.0	165	120	75	16	20
		3.6	175	125	80	20	20
		4.2	180	145	80	20	24
	5.4	3.0	180	115	75	16	20
		3.6	185	125	80	20	20
		4.2	190	145	80	20	24
	6.0	3.0	190	115	80	20	20
		3.6	195	135	80	20	24
		4.2	205	140	95	24	24

TABLE No. 20

FRAME TYPE No. 2			TIMBER STRENGTH: F22				
HEIGHT (m)	SPAN (m)	SPACING (m)	COL DIA (mm)	RIDGE DIA (mm)	BRACE DIA (mm)	BOLT1 (mm)	BOLT2 (mm)
3.0	4.2	3.0	120	85	75	12	12
		3.6	125	95	75	16	16
		4.2	130	100	75	16	16
	4.8	3.0	130	90	75	12	12
		3.6	135	95	75	16	16
		4.2	140	100	75	16	16
	5.4	3.0	140	90	75	16	16
		3.6	145	95	75	16	16
		4.2	150	100	75	16	16
6.0	3.0	145	95	75	16	16	
	3.6	155	100	75	16	16	
	4.2	160	115	80	20	20	
3.6	4.2	3.0	125	95	75	16	16
		3.6	130	100	75	16	16
		4.2	140	105	75	16	16
	4.8	3.0	135	95	75	16	16
		3.6	140	100	75	16	16
		4.2	150	110	75	16	16
	5.4	3.0	145	100	75	16	16
		3.6	150	105	75	16	16
		4.2	155	110	75	16	16
	6.0	3.0	155	100	75	16	16
		3.6	160	105	75	16	16
		4.2	165	115	80	20	20
4.2	4.2	3.0	140	105	75	16	16
		3.6	140	110	75	16	16
		4.2	145	125	80	20	20
	4.8	3.0	140	105	75	16	16
		3.6	145	110	75	16	16
		4.2	150	125	80	20	20
	5.4	3.0	150	105	75	16	16
		3.6	155	110	75	16	16
		4.2	165	120	80	20	20
	6.0	3.0	160	110	75	16	16
		3.6	165	115	75	16	16
		4.2	170	120	80	20	20
4.8	4.2	3.0	160	115	75	16	16
		3.6	160	125	80	20	20
		4.2	160	135	80	20	20
	4.8	3.0	160	115	75	16	16
		3.6	160	125	80	20	20
		4.2	160	130	80	20	20
	5.4	3.0	160	115	75	16	16
		3.6	160	125	80	20	20
		4.2	165	130	80	20	20
	6.0	3.0	165	115	80	16	16
		3.6	170	120	80	20	20
		4.2	175	130	80	20	20

TABLE No. 21

FRAME TYPE No. 3			TIMBER STRENGTH: F22					
HEIGHT (m)	SPAN (m)	SPACING (m)	COL DIA (mm)	RIDGE DIA (mm)	BRACE DIA (mm)	BOLT1 (mm)	BOLT2 (mm)	
3.0	4.2	3.0	100	85	75	12	12	
		3.6	110	90	75	12	12	
		4.2	115	100	75	16	16	
	4.8	4.2	3.0	105	90	75	12	12
			3.6	115	95	75	16	16
			4.2	120	100	75	16	16
	5.4	4.2	3.0	115	90	75	12	12
			3.6	120	95	75	16	16
			4.2	125	100	75	16	16
6.0	4.2	3.0	120	95	75	12	12	
		3.6	125	100	75	16	16	
		4.2	130	105	75	16	16	
3.6	4.2	3.0	120	95	75	12	12	
		3.6	120	100	75	16	16	
		4.2	120	105	75	16	16	
	4.8	4.2	3.0	120	95	75	12	12
			3.6	120	105	75	16	16
			4.2	125	110	75	16	16
	5.4	4.2	3.0	120	100	75	12	12
			3.6	125	105	75	16	16
			4.2	130	110	75	16	16
	6.0	4.2	3.0	125	100	80	16	16
			3.6	130	105	80	16	16
			4.2	135	110	80	16	16
4.2	4.2	3.0	140	105	80	16	16	
		3.6	140	110	80	16	16	
		4.2	140	125	80	20	20	
	4.8	4.2	3.0	140	105	85	16	16
			3.6	140	115	85	16	16
			4.2	140	120	85	16	16
	5.4	4.2	3.0	140	110	85	16	16
			3.6	140	115	85	16	16
			4.2	140	120	85	16	16
	6.0	4.2	3.0	140	110	90	16	16
			3.6	140	115	90	16	16
			4.2	145	120	90	16	16
4.8	4.2	3.0	160	115	90	16	16	
		3.6	160	125	90	20	20	
		4.2	160	130	90	20	20	
	4.8	4.2	3.0	160	115	90	16	16
			3.6	160	120	90	16	16
			4.2	160	130	90	20	20
	5.4	4.2	3.0	160	115	95	16	16
			3.6	160	125	95	16	16
			4.2	160	130	95	20	20
	6.0	4.2	3.0	160	120	95	16	16
			3.6	160	125	95	16	16
			4.2	160	130	95	20	20

TABLE No. 22

FRAME TYPE No. 4			TIMBER STRENGTH: F22					
HEIGHT (m)	SPAN (m)	SPACING (m)	COL DIA (mm)	RIDGE DIA (mm)	BRACE DIA (mm)	BOLT1 (mm)	BOLT2 (mm)	
3.0	4.2	3.0	150	85	75	16	16	
		3.6	155	105	75	16	20	
		4.2	165	105	80	20	20	
	4.8	3.0	160	100	75	16	20	
		3.6	170	105	80	20	20	
		4.2	180	125	80	20	24	
	5.4	3.0	170	105	75	16	20	
		3.6	180	120	80	20	24	
		4.2	190	125	80	20	24	
	6.0	3.0	180	120	80	20	24	
		3.6	190	125	80	20	24	
		4.2	Not recommended, use closer spacing					
	3.6	4.2	3.0	155	90	75	16	16
			3.6	165	105	75	16	20
			4.2	170	110	80	20	20
4.8		3.0	170	105	75	16	20	
		3.6	175	105	80	20	20	
		4.2	185	125	80	20	24	
5.4		3.0	180	105	75	16	20	
		3.6	190	120	80	20	24	
		4.2	195	125	80	20	24	
6.0		3.0	190	105	80	20	20	
		3.6	200	125	80	20	24	
		4.2	Not recommended, use closer spacing					
4.2		4.2	3.0	165	90	75	16	16
			3.6	170	105	75	16	20
			4.2	175	110	80	20	20
	4.8	3.0	175	105	75	16	20	
		3.6	185	105	80	20	20	
		4.2	190	125	80	20	24	
	5.4	3.0	185	105	75	16	20	
		3.6	195	125	80	20	24	
		4.2	205	125	80	20	24	
	6.0	3.0	200	105	80	20	20	
		3.6	205	125	80	20	24	
		4.2	215	145	95	24	24	
	4.8	4.2	3.0	170	105	75	16	20
			3.6	175	110	80	20	20
			4.2	185	120	80	20	20
4.8		3.0	180	105	75	16	20	
		3.6	190	110	80	20	20	
		4.2	195	125	80	20	24	
5.4		3.0	195	105	75	16	20	
		3.6	200	125	80	20	24	
		4.2	210	130	80	20	24	
6.0		3.0	205	105	85	20	20	
		3.6	215	125	85	20	24	
		4.2	220	145	95	24	24	

TABLE No. 23

FRAME TYPE No. 5			TIMBER STRENGTH: F22				
HEIGHT (m)	SPAN (m)	SPACING (m)	COL DIA (mm)	RIDGE DIA (mm)	BRACE DIA (mm)	BOLT1 (mm)	BOLT2 (mm)
3.0	4.2	3.0	130	75	75	12	12
		3.6	135	90	75	16	16
		4.2	140	95	75	16	16
	4.8	3.0	140	75	75	12	12
		3.6	145	90	75	16	16
		4.2	150	95	75	16	16
	5.4	3.0	150	90	75	16	16
		3.6	155	95	75	16	16
		4.2	160	95	75	16	16
6.0	3.0	155	90	80	16	16	
	3.6	155	95	80	16	16	
	4.2	170	110	80	20	20	
3.6	4.2	3.0	135	75	75	12	12
		3.6	145	90	75	16	16
		4.2	150	95	75	16	16
	4.8	3.0	145	80	75	12	12
		3.6	155	95	75	16	16
		4.2	160	95	75	16	16
	5.4	3.0	155	90	75	16	16
		3.6	165	95	75	16	16
		4.2	170	100	75	16	16
	6.0	3.0	165	90	85	16	16
		3.6	175	95	85	16	16
		4.2	180	115	85	20	20
4.2	4.2	3.0	140	90	75	16	16
		3.6	150	95	75	16	16
		4.2	155	95	75	16	16
	4.8	3.0	150	90	75	16	16
		3.6	160	95	75	16	16
		4.2	165	95	75	16	16
	5.4	3.0	160	90	85	16	16
		3.6	170	95	85	16	16
		4.2	175	100	85	16	16
	6.0	3.0	170	95	90	16	16
		3.6	180	95	90	16	16
		4.2	185	115	90	20	20
4.8	4.2	3.0	160	90	75	16	16
		3.6	160	95	75	16	16
		4.2	160	110	80	20	20
	4.8	3.0	160	90	85	16	16
		3.6	165	95	85	16	16
		4.2	170	100	85	16	16
	5.4	3.0	170	90	90	16	16
		3.6	175	95	90	16	16
		4.2	180	115	90	20	20
	6.0	3.0	180	95	95	16	16
		3.6	185	100	95	16	16
		4.2	195	115	95	20	20

TABLE No. 24

FRAME TYPE No. 6			TIMBER STRENGTH: F22				
HEIGHT (m)	SPAN (m)	SPACING (m)	COL DIA (mm)	RIDGE DIA (mm)	BRACE DIA (mm)	BOLT1 (mm)	BOLT2 (mm)
3.0	4.2	3.0	105	75	75	10	10
		3.6	110	80	75	12	12
		4.2	115	85	75	12	12
	4.8	3.0	115	75	75	12	12
		3.6	120	80	75	12	12
		4.2	125	95	75	16	16
	5.4	3.0	120	80	80	12	12
		3.6	130	95	80	16	16
		4.2	135	95	80	16	16
6.0	3.0	130	85	90	12	12	
	3.6	135	95	90	16	16	
	4.2	140	100	90	16	16	
3.6	4.2	3.0	120	80	75	12	12
		3.6	125	85	75	12	12
		4.2	125	95	75	16	16
	4.8	3.0	120	80	85	12	12
		3.6	125	95	85	12	12
		4.2	130	95	85	16	16
	5.4	3.0	130	85	90	12	12
		3.6	135	95	90	16	16
		4.2	140	100	90	16	16
	6.0	3.0	135	90	95	12	12
		3.6	140	95	95	16	16
		4.2	145	100	95	16	16
4.2	4.2	3.0	140	85	85	12	12
		3.6	140	90	85	16	16
		4.2	140	95	85	16	16
	4.8	3.0	140	85	90	12	12
		3.6	140	95	90	16	16
		4.2	140	95	90	16	16
	5.4	3.0	140	90	95	12	12
		3.6	140	95	95	16	16
		4.2	145	100	95	16	16
	6.0	3.0	140	95	100	16	16
		3.6	145	95	100	16	16
		4.2	155	100	100	16	16
4.8	4.2	3.0	160	90	95	16	16
		3.6	160	95	95	16	16
		4.2	160	95	95	16	16
	4.8	3.0	160	90	100	16	16
		3.6	160	95	100	16	16
		4.2	160	100	100	16	16
	5.4	3.0	160	90	105	16	16
		3.6	160	95	105	16	16
		4.2	160	100	105	16	16
	6.0	3.0	160	95	110	16	16
		3.6	160	100	110	16	16
		4.2	160	105	110	16	16

**APPENDIX 8
PROPOSED MINIMUM HOUSE
SPECIFICATION AND PLANS
SPECIFICATION NOTES
MINIMUM HOUSE FOR POLE**

CONSTRUCTION

To be read in conjunction with plans.

GENERALLY

All work is to be carried out in accordance with Ordinance 70 and as directed by responsible authorities.

EXCAVATION (& CONCRETE)

Clear actual building site of all vegetation and obstructions.

Set out centres of stumps and excavate holes to depth indicated. Pour unreinforced concrete footing 250 mm diam. x 100 mm deep. Excavate for the grease trap and absorption trenches as directed and cess pit as necessary.

CARPENTRY

All stumps are to be Class 1 durability hardwood with sap wood removed. Provide galvanised iron ant caps and bent 6 mm straps to secure bearers to stumps. All floor, wall and roof framing to be local unsawn hardwood. Poles are to be shaved at supports to provide jointing face. Column poles are to be halved, and all beams notched at supports are to be banded with 1 mm galvanised steel traps.

Sawn hardwood joists are to be packed as necessary for a level floor and laid with selected seasoned tongued and grooved flooring. Verandah flooring is to be seasoned, chamfered hardwood boards with 6 mm spaces.

JOINERY

Infill walling is to be constructed with 75 mm diameter studs and plates and galvanised 1 mm strap bracing and clad externally with local hardwood flitches, lapped minimum of 18 mm. Build in frames ex 38 mm hardwood with 12 mm rebates to suit approved secondhand doors and windows.

Securely fix stock ladder to both floor and ceiling joists with 1 mm galvanised straps.

ROOFING

Roof with standard corrugated galvanised steel laid with 1½ convolutions side lap and minimum 150 mm end lap. Paint laps with metal primer. Fix according to manufacturer's recommendations. Ensure entire roof structure is adequately strapped and bolted to wall framing to resist uplift.

PLUMBING

Line section of floor and surrounds under stove and wall behind stove with 0.5 mm galvanised steel sheet fixed with galvanised clouts.

Position fuel stove and fit 100 mm diameter galvanised flue pipe complete with bends and straps, wall junction piece and chinamans hat.

Fix stainless steel sink and drainer and connect to site water supply with standard black PVC hose and fittings for cold water only.

DRAINAGE

Install grease trap and absorption trenches as directed. Connect bathing facility as necessary.

Construct cess pit and enclosure all as directed.

COMPLETION:

Ensure building is weatherproof.

(This appendix is not subject to copyright)

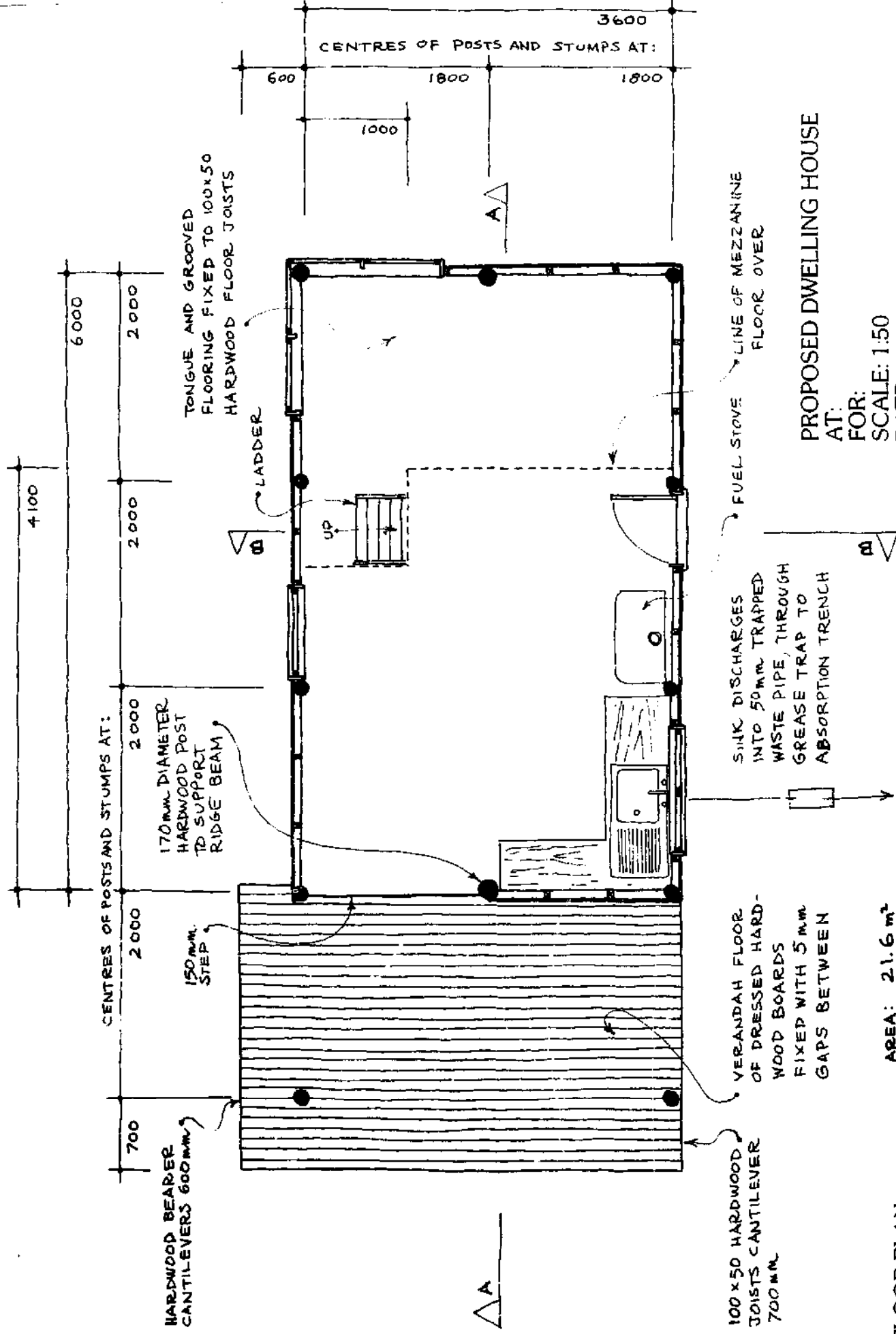

PROPOSED DWELLING HOUSE
AT:
FOR:
SCALE: 1:50
DATE:

AREA: 21.6 m²
MEZZANINE: 14 m²
VERANDAH: 11 m²

FLOOR PLAN

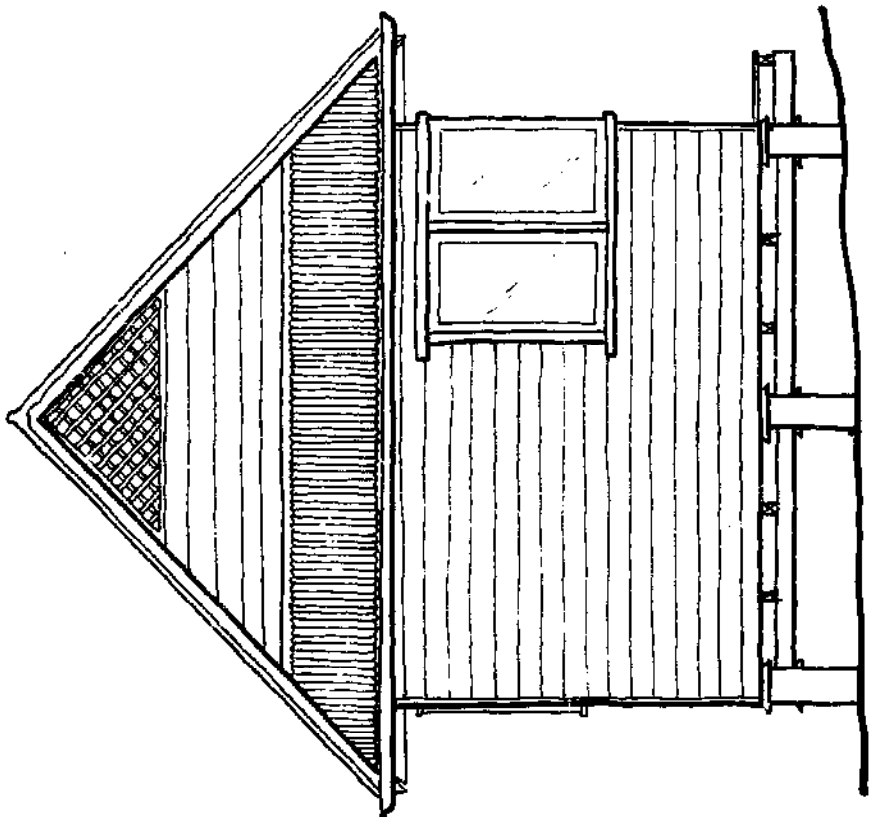

END ELEVATION

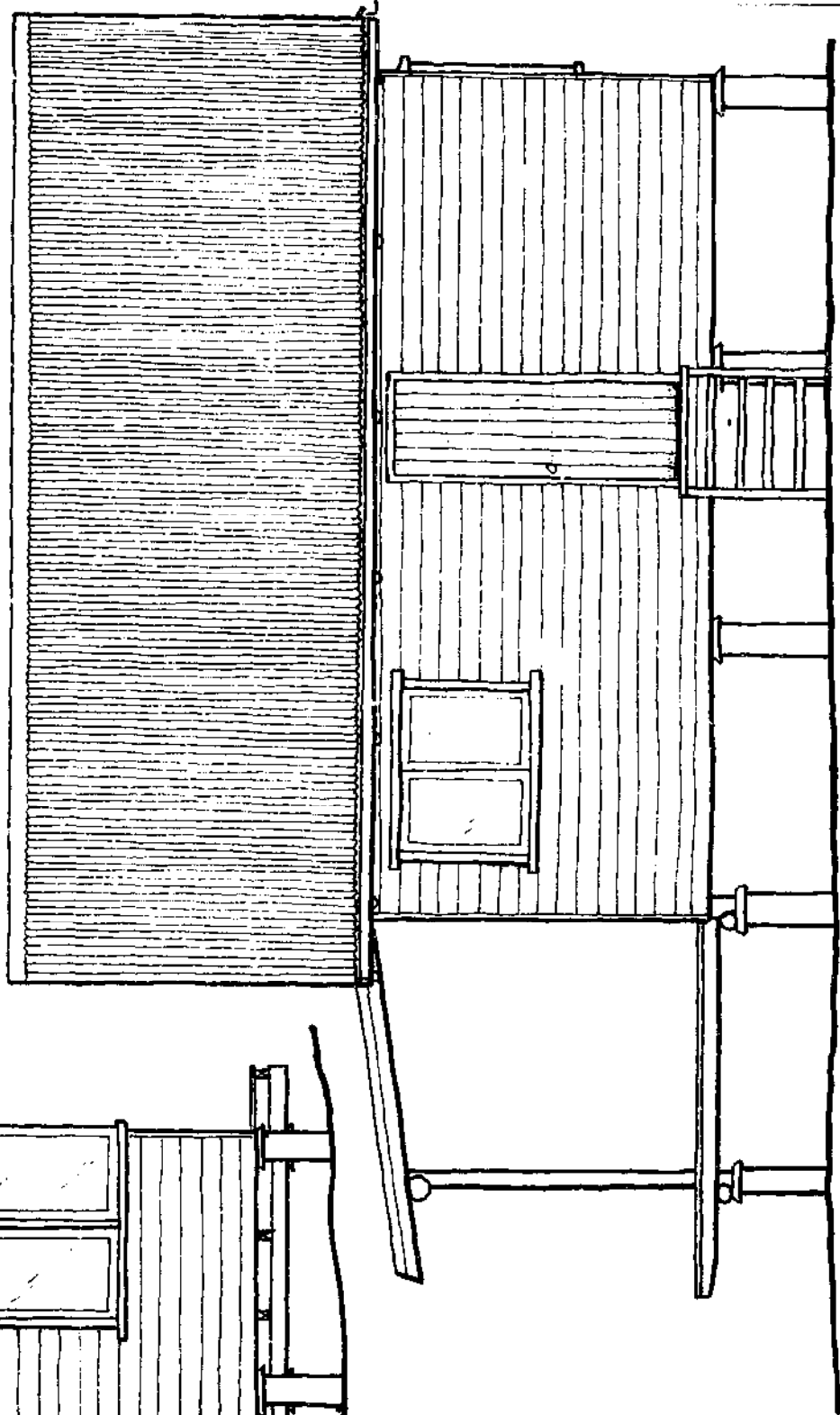

SIDE ELEVATION

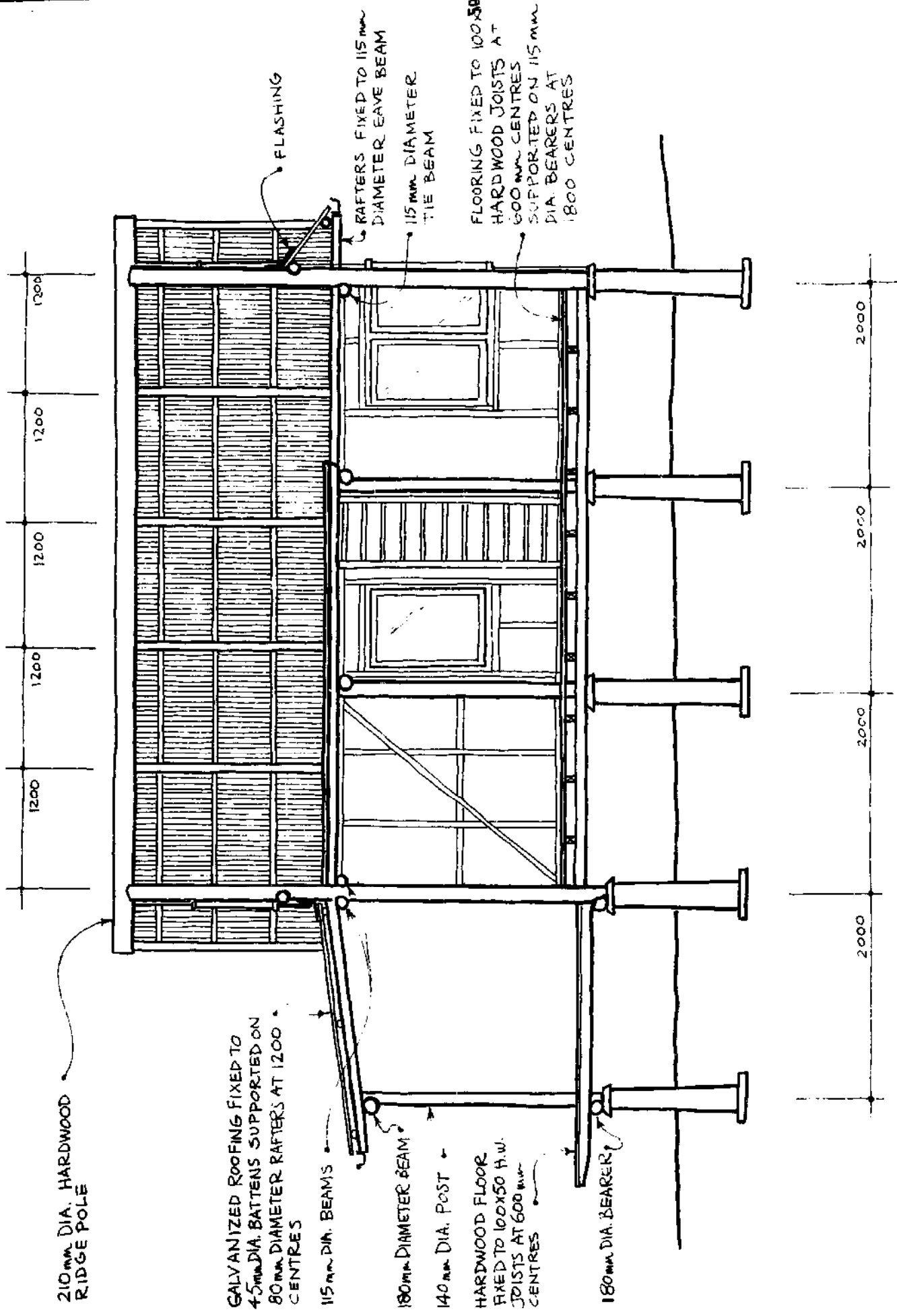

210 mm DIA. HARDWOOD RIDGE POLE

GALVANIZED ROOFING FIXED TO 45 mm DIA. BATTENS SUPPORTED ON 80 mm DIA. RAFTERS AT 1200 mm CENTRES

115 mm DIA. BEAMS

180 mm DIA. BEAM

140 mm DIA. POST

HARDWOOD FLOOR FIXED TO 100x50 H.W. JOISTS AT 600 mm CENTRES

180 mm DIA. BEARER

FLASHING

RAFTERS FIXED TO 115 mm DIA. EAVE BEAM

115 mm DIA. TIE BEAM

FLOORING FIXED TO 100x50 H.W. JOISTS AT 600 mm CENTRES SUPPORTED ON 115 mm DIA. BEARERS AT 1800 mm CENTRES

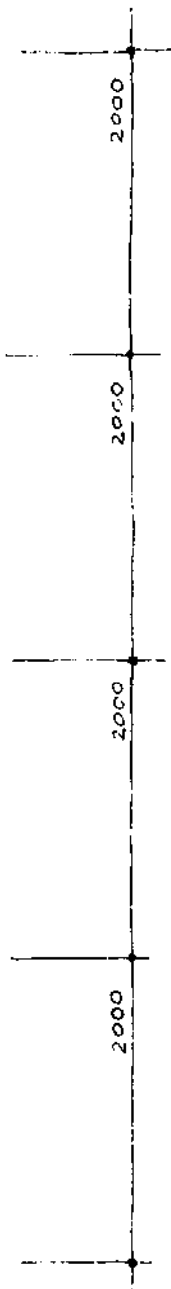
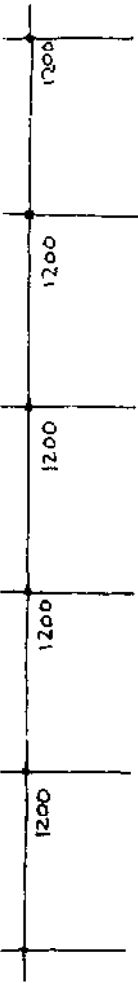

SECTION A-A

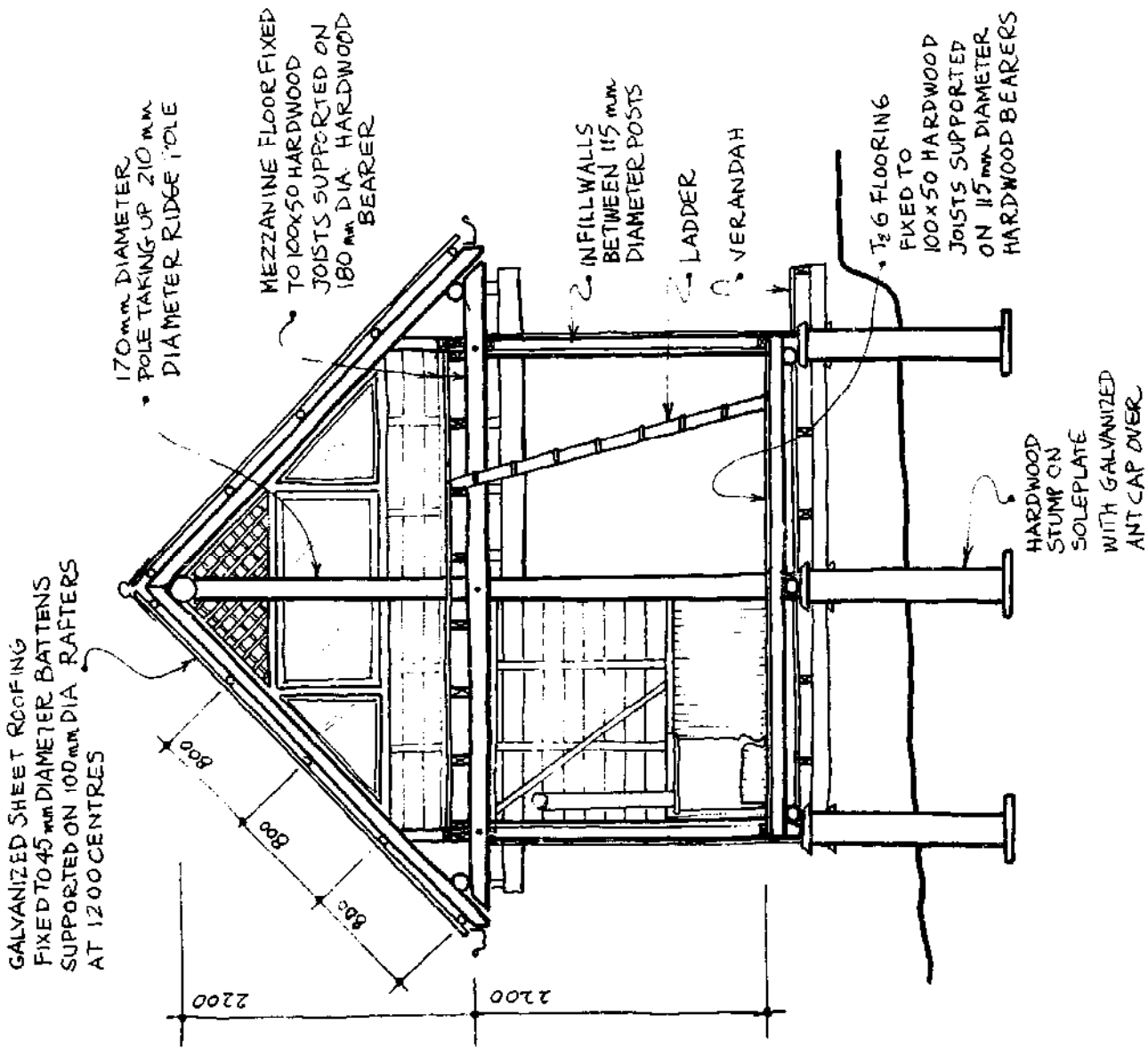

APPENDIX 9

Australian Standards

The following Australian Standards should be of use to the owner-builder. Up-to-date lists of standards and their prices are available from the Standards Association of Australia, at:

80 Arthur Street, North Sydney, N.S.W. 2060

51 King Street, Newcastle, N.S.W. 2300

447 Upper Edward Street, Brisbane, Qld. 4000

AS 1170	SAA Loading Codes. Part 1: Dead and Live Loads, Part 2: Wind Loads.	AS 1903-1976	Reflective foil laminate (bound with AS 1904)
AS 1684-1979	SAA Timber Framing Code (Tables of sizes and spans issued as Supplements)	AS A98-1959	Bituminous felt roofing, Type 1(a) — Saturated organic fibre felt roofing
AS 1720-1975	SAA Timber Engineering Code	AS A99-1959	Bituminous felt roofing, Type 1(c) — Coated organic fibre felt roofing
AS CC12-1968	Adequate electrical installations in single and multiple domestic dwellings	AS 1859-1976	Flat pressed particleboard
AS 1606-1974	Water-repellent treatment of timber, joinery and other timber products	AS 2269-1979	Structural plywood
AS 1694-1974	Physical barriers used in the protection of buildings against subterranean termites.	AS 2270-1979	Plywood and blockboard for interior use
AS 1736-1975	Roof sarking	AS 2271-1979	Plywood and blockboard for exterior use
AS 1860-1976	Installation of particleboard flooring	AS 2272-1979	Marine plywood
AS 1904-1976	Installation of reflective foil laminate in buildings (bound with AS 1903)	AS 2324-1979	PVC film and sheeting
AS 2002-1979	Installation of household type solar hot water supply systems	AS 0114-1968	Hardboard
AS 2032-1979	Installation of UPVC pipe systems	AS 0116-1968	Organic fibre and insulating board
AS 2033-1979	Installation of polyethylene pipe systems	AS 1540-1974	Timber frames and sashes for windows
AS 2057-1977	Soil treatment for protection of buildings against subterranean termites	AS 1641	Milled products from Australian rainforest timber
AS 2147-1978	Installation of timber windows in buildings (bound with AS 2146)	AS 1702	Milled products from south-eastern Australian hardwoods
AS 2178-1978	Treatment of subterranean termite infestation in existing buildings	AS 1706 to 1709-1974	Milled products from north-eastern Australian eucalypt hardwoods
AS 2180-1978	Selection and installation of metal rainwater goods (bound with AS 2179)	AS 1728-1975	Types of timber surfaces
AS CA39-1963	The sanding of interior wooden floors	AS 1782 to 1787-1975	Milled products from Australian grown conifers (softwoods) (excluding radiata pine and cypress pine)
AS CA55-1970	Design and installation of bituminous fabric roofing	AS 1810-1975	Flooring milled from cypress pine
AS CA56-1968	Construction of vitrified clay pipelines (up to and including 12-in diameter with flexible or rigid joint systems)	AS 091 to 094-1964	Unseasoned cypress pine sawn boards and milled products
SAA MH2-1975	Metric data for building designers	AS 1328-1972	Glued-laminated structural timber
AS 02-1970	Nomenclature of Australian timbers	AS 1489-1973	Sawn boards from radiata pine
AS 1445-1977	76 mm pitch corrugated hot-dipped zinc-coated or aluminium zinc-	AS 070-1958	Sawn house stumps, sole plates, fence posts and struts from south-eastern Australia hardwoods
		AS 1218-1972	Flushing cisterns
		AS 1229-1972	Laundry troughs
		AS 1546-1976	Small septic tanks
		AS 1589-1979	Copper and copper based alloy fittings for use in sanitary plumbing installations
		AS 1646-1977	Rubber joint rings for water supply, sewerage and drainage purposes
		AS 1718-1975	Copper alloy draw-off taps, stop taps and ferrule or main taps for use in water supply and hot water services
		AS 1730-1975	Washbasins

AS 1756-1975	Stainless steel sinks
AS 2023-1977	Baths for domestic purposes
AS A162-1969	Plastics waste traps
AS 1159-1979	Polyethylene (polythene) pipe for pressure applications
AS 1254-1973	Unplasticized PVC (UPVC) pipes and fittings for storm or surface water applications
AS 1260, Parts 1 to 5-1974	Unplasticized PVC (UPVC) pipes and fittings for sewerage applications
AS 1273 Parts 1 and 2-1974	Unplasticized PVC (UPVC) downpipe and fittings for rainwater
AS 1342-1973	Precast concrete drainage pipes
AS 1415, Parts 1 to 5-1974	Unplasticized PVC (UPVC) pipes and fittings for soil, waste and vent (SWV) applications
AS 1432-1973	Copper tubes for water, gas and sanitation
AS 1464, Parts 1 to 3-1974	Unplasticized PVC (UPVC) pipes and fittings for gas reticulation
AS 1477, Parts 1 to 6-1973	Unplasticized PVC (UPVC) pipes and fittings for pressure applications
AS 1585-1976	Capillary and brazing fittings of copper and copper alloy
AS 1610-1974	Threaded brass hose couplings for use with taps and watering devices
AS 1628-1977	Copper alloy gate valves and non-return valves for use in water supply and hot water services.
AS 1645-1974	Copper and copper alloy compression fittings for use in water supply and hot water services
AS 1693	Rubber ring joints for vitrified clay pipes
Part 1-1975	100 mm diameter
Part 2-1977	150 mm diameter
AS 1741-1975	Vitrified clay pipe
AS 2179-1978	Metal rainwater goods (bound with AS 2180)
AS 1700-1974	Mineral turpentine
AS K2 to K6-1928	Linseed oil
AS 1143-1973	High temperature creosote for the preservation of timber
AS 1144-1973	Arsenical creosote for the preservation of timber
AS 1607-1974	Water-repellent solutions for the treatment of timber, joinery and other timber products
AS 1650-1974	Galvanized coatings on ferrous articles
AS 1547-1973	Disposal of effluent from small septic tanks
AS Interim Code 320	The disposal of domestic sullage

APPENDIX 10

Experimental Building Station Publications

NOTES ON THE SCIENCE OF BUILDING

No.	
2	Footings for Small Masonry Buildings on Sand, Gravel or Rock
6	Footings for Small Masonry Buildings on Plastic Soil : General Considerations
9	The Design of Footings for Small Masonry Buildings on Plastic Soil
11	White Ants
13	Earth-wall Construction
18	Pise Construction
21	House Design for Temperate Climates
26	Wood Borers
27	Arch Bars and Angle Lintels for Brick Walls
28	Concrete
30	Behaviour of Building Materials in Tropical Regions
31	Domestic Fireplaces and Chimneys
32	House Design for Australian Cold-winter Climates
33	Small Retaining Walls
34	Timber in Domestic Buildings
35	Thermal Considerations in House Design
36	Concrete Floors on the Ground in Domestic Construction
38	Fire in Buildings
39	Damp-proof Courses and Flashings
40	Suspended Concrete Floors for Minor Uses
41	Pier-and-beam Construction
42	Claddings for Framed Buildings
43	Natural Ventilation of Buildings
44	Traditional Roof Framing for Tiled Roofs
45	Timber Floors in Dwellings
48	Noise in Buildings
51	Domestic Hot Water
52	Dampness in Buildings
54	Small Basements and Cellars
55	Domestic Construction
56	Daylighting of Buildings
57	Movement-control Joints in Masonry Walls
58	Concrete Floors on the Ground for Commercial Buildings
59	Cleaning of Brickwork
61	Condensation in Dwellings
62	Brick-veneer Construction
63	House Design for Hot Climates
64	Wall Linings for Timber-frame Buildings
65	Structural Application of Masonry Units
66	Fire Aspects of Combustible Wallboards and Finishes
67	Concrete Shell and Folded-plate Roofs
68	Some Common Oversights in Building
69	Minimising Heat Gain in Buildings
70	Mortars for Unit Masonry Construction
71	Plaster Mixes
72	Steel Lintels for Garage Door Openings
73	Epoxy Resins
74	Constructing Pier-and-beam Footings
75	Cooling the Home
76	Silicone Water-repellents for Masonry
77	Toppings for Concrete Floors
78	Some Condensation Problems
79	Corrosion of Metals in Building
80	Some Common Noise Problems
81	Cracking in Concrete Slabs

82 Curtain Walls
 83 Summer Comfort in Industry
 84 The Weatherproofing of Buildings
 85 Hollow Concrete Blocks
 86 Insulating a House
 87 Fire-resisting Construction
 88 Wind damage to Buildings
 89 Sub-surface Drainage
 90 Materials for Fire-resisting Construction
 91 Floor Finishes for Commercial Buildings
 92 Concrete Lintels for Garage Door Openings
 93 Artificial Lighting of Offices
 94 Weatherproofing of Movement Joints in Walls
 95 Physiological Aspects of Space Heating
 96 Septic Tanks and Grease Traps for Domestic Use
 97 Stabilisation of Building Sites and Access Roads with Lime
 98 Lightweight Fire-resisting Construction
 99 Colour Treatment of Work Spaces
 100 The Use of Admixtures in Concrete
 101 Roofing Materials
 102 Concrete Surface Finishes
 103 Industrial Timber Floors
 104 Approval of Building Materials
 105 The Design and Control of Concrete Mixes
 106 Artificial Lighting of Factories
 107 Fire in Multi-storey Buildings
 108 Off-The-Form Concrete Finishes
 109 Terrazzo in Domestic Construction
 110 Site Investigation of Foundations
 111 Fixing of Stone Veneer Cladding
 112 Joints in Suspended Concrete Floor Slabs
 113 Foundation Movement — Its Causes and Its Effects on Buildings on Shallow Footings
 114 Windows and the Indoor Environment
 115 Curing Compounds for Concrete
 116 Noise Problems in Buildings
 117 Magnesite Flooring
 118 Fire Safety in Apartment Buildings
 119 Testing Bricks
 120 Shadow Angles
 121 Timber Fasteners
 122 Fire Protection of Electronic Equipment
 123 Cements
 124 Internal Ceramic Tiling
 125 Prestressed Concrete
 126 Manufacture of Clay Bricks
 127 Carpets
 128 Manufacture of Concrete Bricks and Blocks
 129 Unit Paving
 130 Performance Standards
 Index to NSB numbers 1 to 130 inclusive
 131 Bituminous Driveways
 132 Sound Absorption
 133 Aggregate for Concrete
 134 Differential Movement in Buildings Clad with Clay Bricks: Magnitude of Differential Movements
 135 Differential Movement in Buildings Clad with Clay Bricks: Design of Expansion Gaps
 136 Fire Doors, Fire Shutters and Fire Windows
 137 Fire Hazards of Furniture and Furnishings
 138 Explosives in Building: Types of Explosive
 139 Explosives in Building: Use in Building Excavation
 140 In-situ Concrete Driveways
 141 Pond Strength of Masonry
 142 Fire Hazards in the Home
 143 Domestic Solar Water Heating
 144 Unscheduled Pouring Breaks

145 Project Network Techniques: Network Diagram Construction
 146 Project Network Techniques: Time Scheduling

NOTES ON THE SCIENCE OF BUILDING CLASSIFIED INDEX

ACOUSTICS
 48 80 116
 CLIMATE AND BUILDING DESIGN
 21 30 32 35 63 69 75 83 86 95 114 120
 CONCRETE
 28 100 102 105 108 115 123 125 128 133 144
 DAMP, CORROSION, WIND
 52 61 76 78 79 84 88 94
 DRIVEWAYS AND PATHS
 129 131 140
 EARTH-WALL CONSTRUCTION
 13 18
 FIRE
 38 66 87 90 98 107 118 122 136 137 142
 FLOORS
 36 40 45 58 77 81 91 103 109 112 117 127
 FOOTINGS AND EXCAVATION
 2 6 9 41 54 74 97 110 113 138 139
 HEAT, VENTILATION, PLUMBING
 31 43 51 89 96 143
 LIGHTING, COLOUR
 56 93 99 106
 MASONRY
 39 57 59 62 65 70 85 119 126 134 135 141
 PLANNING AND APPROVALS
 104 130 145 146
 ROOFS
 67 101
 TIMBER
 11 26 34 44 121
 WALLS
 27 33 42 64 71 72 82 92 111 124
 MISCELLANEOUS
 55 68 73

BULLETINS

No.
 1 The Structural Sufficiency of Domestic Buildings
 5 Earth-wall Construction — Pise, or Rammed Earth; Adobe, or Puddled Earth; Stabilised Earth
 6 Designing Houses for Australian Climates
 7 The Design of Buildings for Daylighting
 8 Sunshine and Shade in Australasia
 9 Fire Protection in Buildings

TECHNICAL STUDIES

- No.
13 Report on Simulated Wind Pressure Tests
20 Recommended Interim Code of Practice for Concrete Walls, Type IV
31 Foundation Soils in Australia
33 Climate and Design of Buildings
34 Climate and Design of Buildings — The Thermal Behaviour of Dwellings
42 Pier-and-beam Footings for Single-storey Domestic Construction
43 Cracking in Brick and Block Masonry
44 Footings on Problem Soils
45 The Use of Admixtures in Concrete
46 Stone Veneer Cladding
47 The Weathering of City Buildings
48 Airborne Sound Transmission Through Elements of Buildings

SPECIAL REPORTS

- No.
19 Air Movement in Industrial Buildings — Effects of Nearby Buildings
20 Gypsum-plaster Wall Panels
22 Circumferential Stresses in a Joint between Structural Tubes
23 Shear in Flat-slab Construction under Uniform Loading
24 Small Specimens of Brickwork as Design and Construction Criteria

These publications are available from the Experimental Building Station, Department of Housing & Construction, P.O. Box 30, Chatswood, 2067.

APPENDIX 11

Submissions Received

Submissions were received from the following individuals and organisations. Most contributions have been incorporated into the handbook and amendments made where appropriate. However, some material was rejected if it was already covered by commonly available reference material, was more appropriate in a practical building manual, in conflict with Ordinance 70, or not very low cost building standards.

The editors of the handbook gratefully acknowledge the submissions received and the care and effort that went into their preparation.

John Archer, author

Roger Bartlett, Department of Environment and Planning

Doug Crawford, Department of Environment and Planning

Simon Clough, homebuilder, Tweed

Jack Dalgarno, architect/homebuilder

Richard Downes, builder, Sydney

J. Gooch, Forestry Commission of N.S.W.

M. Gormly, A. Hopkins, D. Pont, homebuilders, Moruya

Peter Hamilton, Homebuilders' Association

Harry Harris, engineer/homebuilder, Uki

David Kanaley, Department of Environment and Planning

Richard le Plastrier, architect, Lovetts Bay

J.F. Lyons, Blacktown City Council

Margaret Munro-Clark, University of Sydney

Peter Middleton, University of Sydney

Dennis McManus, architect, Department of Environment and Planning

Fergus Neilson, Department of Environment and Planning

Chris Nash, builder, Stroud

John Paynter, Department of Environment and Planning

Lester Prowse, electrician, Mullumbimby

Ron Short, Bellingen Shire Council

R.D. Spence, Tweed Shire Council

John Watson, homebuilder, Nimbin

Stafford Watts, Department of Environment and Planning

Neil Wilson, Department of Environment and Planning
Health Commission of N.S.W.

Homebuilders' Association, Rainbow Region

Royal Australian Institute of Architects, Housing Committee, Building Regulation and Standards Committee

REFERENCES

Acts and Ordinances:

- Local Government Act N.S.W. 1919;
Public Health Act N.S.W.;
Builders' Licensing Act N.S.W. 1979;
Ordinances 44, 45, 70 and 71;
Draft Appendix 4 to the Queensland Building Act.
Commonwealth Department of Housing and
Construction Experimental Building Station. "Notes on
the Science of Building" series.
Commonwealth Scientific and Industrial Research
Organisation. *The importance of Preservation
Treatments in Hardwood Utilization*, N. Tamblyn.
Division of Forest Products Leaflets.
Division of Mechanical Engineering Bulletins.
Papua and New Guinea Forest Products Research
Centre. *Manual of Rural Wood Preservation; Pole
Buildings in Papua and New Guinea*.
Forestry Commission of N.S.W., "Technical
Publications".
Standards Association of Australia, "Australian
Standards".
"British Standard Code of Practice for the Structural
Use of Masonry."
Timber Development Association. *Technical Timber
Guides; Australian Timber Handbook*, N.K. Wallis;
Span Tables.
Commonwealth Savings Bank, *Housing Loans —
Acceptable Standards of Construction*.
The Ross Institute Information Advisory Service —
Bulletin No. 8, *Small Excreta Disposal Systems*.
Department of Environment and Planning.
"Guidelines for Siting Rural Dwellings in Coastal
Areas". Technical Bulletin No. 11.
Uni. N.S.W. Graduate School of the Built Environment.
Earth Construction, An Advisory Document.
The International Development Research Centre,
Low Cost Technology Options for Sanitation.

Bootle, Keith R., 1971. *The Commercial Timbers of
N.S.W. and Their Use* Sydney. Angus and Robertson.
Forestry Commission of N.S.W., 1974. *Preservation of
Natural Round Fence Posts*. W.T.6.
Forestry Commission of N.S.W., 1975. *The
Immunisation of Timber against attack by Powder Post
Beetle (Ilyctus brunneus) with Borates*. R.S. Johnstone.
WT 14.
Hall, Norman, R.D. Johnston and G.M. Chippendale.
1970. *Forest Trees of Australia*, 3rd edition. Canberra,
AGPS. (Now out of print)
Holliday, Ivan, and Ron Hill. 1974. *A Field Guide to
Australian Trees*. Revised edition. Adelaide, Rigby.
Kearn & Magers, 1978. *Fireplaces*. Oakhurst, Calif.,
Owner Builder Publications.
Vivian, John, 1976. *Building Stone Walls*. Charlotte,
Ver., Garden Way Publications.
Wrigley, John W., 1979. *Australian Native Plants: A
Manual for their Propagation, Cultivation and Use in
Landscaping*. Sydney, Collins.

GLOSSARY OF BUILDING TERMS

Adobe

Puddled (*q.v.*) earth blocks usually reinforced with straw or other fibrous binders. Earth material is kneaded into portable moulds used for shaping the blocks. (See also *pise, stabilised earth*).

Ant capping

A system of sheet metal shields, usually galvanised iron, whose purpose is to prevent the passage of termites (white ants) from the soil to the timber portions of a building. In the case of isolated piers or stumps supporting timber floors, the top of each pier or stump is covered with metal which extends on all sides and is turned down at 45°. In the case of continuous masonry walls, continuous metal strips are built into the wall below the lowest timbers and are extended beyond the wall face and turned down at 45°. All joints or mitres in the metal should be soldered.

Architrave

A moulding surrounding a door or window opening.

Bagging

A masonry process in which thin mortar is applied to the face of the work with some coarse material.

Barge board

The board covering the face of the roof timbers on the gable or skillion end of a building.

Battens, roof

Small timbers fixed to the tops of rafters to which the roof coverings may then be secured.

Beam, cantilever

A beam projecting with one end unsupported.

Bearer

A sub-floor timber supporting the floor joists.

Birdsmouth

A notch cut in a rafter to fit over the wall plate or beam.

Bonding

The method of laying bricks whereby the over-lapping or bond is provided for by arranging the bricks so that in any one course there shall be none of the vertical joints directly over the vertical joints in the course next underneath. The type most commonly used in Australia is stretcher bond which comprises bricks placed with their lengths in the direction of the length of the wall.

Brace

A length of timber placed at an angle across other timbers to make them rigid.

Cement, Portland

The product obtained by crushing and burning limestone in kilns, the resulting clinker being finely ground with gypsum. It is the principal building cement in use, and with the addition of various aggregates is used for many purposes in building, e.g. concrete, brickwork mortar, plasterers' "compo".

Cladding

A term applied to relatively thin sheets or slabs used to enclose a framework.

Clout

A nail, usually galvanised, with a flat circular head.

Compo-mortar

Mortar made of cement, lime and sand. In some States the term is now applied also to cement mortar.

Concrete, no fines

Concrete composed of coarse aggregate, cement and water (no sand).

Concrete, reinforced

Concrete reinforced or strengthened by the inclusion of steel mesh, bars, rods, etc.

Contour

The outline revealed by a cross-section. In land surveying, a plan of lines joining all points of the same height above or below a predetermined datum level is called a contour plan.

Course

A continuous layer of bricks, stones or other building units in a wall.

Cover mould

A flat mould of fibrous plaster, asbestos cement or other material, used to cover the joints of sheets.

Creosote

By-product obtained by distillation of tar; an effective wood preservative.

Damp-course

A waterproof membrane laid between courses of brickwork or masonry. Various types of material are used among which are an approved admixture of liquid damp-proofing with ordinary mortar; lead-cored bituminous damp-course; asphaltic damp-course; polythene and sheet copper.

Details

In architecture, the smaller parts into which a composition may be divided, which may require special treatment.

Door frame

A frame into which a door is fitted.

Door jambs

The two vertical members of a door frame; the term is generally applied to the linings of internal doorways.

Door, ledged and braced

A ledged door with diagonal braces inserted between ledges.

Door stops

Fillets fixed to door jambs to form a stop and rebate for the door.

Downpipes

Pipes generally fixed to walls, to carry roof water from eaves gutters to storm-water drains at ground level.

Dressing

The smoothing of timber or forming into a desired shape of other material, e.g. lead.

Earthed

Connected to the general mass of earth in a manner that will ensure at all times an immediate and safe discharge of electricity.

Eaves

The lower part of a roof that overhangs the wall.

Elevation

(1) A geometrical drawing of a facade of a building; (2) the facade itself.

Firebrick

A brick specially manufactured to resist high temperatures; used in fireplaces, furnaces, etc.

Flashings

Pieces of galvanised iron, lead or other impervious material used in many parts of a house to prevent the

penetration of moisture.

Flashing, stepped

Shaped pieces of material used for flashings where a sloping roof abuts a wall or chimney. Each piece of material is inserted into the wall joints and dressed over the roofing material.

Footing

The construction whereby the weight of the structure is transferred from the base structure to the foundation (*q.v.*).

Formwork

Prepared forms of timber or other material for the casting of concrete work.

Foundation

The ground upon which the footings of a building are constructed.

Frame

(1) In joinery, the name given to the frame around a door or window opening; (2) in carpentry, the main timbers of a structure when fitted and joined together.

Gable

The triangular end of a house formed at the end of a pitched roof, from eaves line to apex.

Glazing, bead

Small moulding for holding glass in place.

Grout

Mortar made thin by the addition of water so that it will run into open joints, for the purpose of ensuring the structural solidity of brickwork.

Halving

A joint made by cutting the opposite halves of the thicknesses out of two pieces of timber, to the full width of the timber.

Head

The upper horizontal member of a door or window frame, or the top of an opening.

Hearth

The floor of a fireplace, including a small area in front of the fireplace specially paved with incombustible materials.

Height, ceiling

The height of a room measured from floor surface to ceiling or, where there is no ceiling, to the underside of the rafters.

Hip

A slanting ridge formed by the intersection of two sloping roof surfaces.

Hip roof

A roof roughly pyramidal in shape, with surfaces sloping upwards from all the eaves.

House (v.)

To recess the end of one piece of timber into another without reducing the thickness of the former piece.

Inspection opening

(Plumbing), an opening, sealed with a removable disc, provided in a pipe or fitting for inspection or cleaning purposes.

Jambs

Side surfaces of an opening in a wall. (See also *reveal*).

Jamb linings

Linings of internal door or window openings.

Joists, ceiling

Timber members spanning walls or other supports, to which the ceiling is attached.

Joists, floor

Timber members to which the flooring is fixed.

Lap, end

In roofing, the amount by which the upper sheet or unit of roofing overlaps the sheet or unit immediately below it.

Lap, side

In roofing, the amount by which sheets or units of roofing materials overlap each other at the side joints. In plain sheeting, tiles, etc. the side lap is stated in mm, but in corrugated sheeting it is generally quoted in corrugations, e.g. half, one, one and a half, etc.

Linear (running)

A measurement of length.

Lintel

A horizontal load-bearing member spanning an opening.

Load, dead

The actual weight of all permanent structural and finishing work in a building, including partition walls.

Load, live

All load other than dead load, including wind load (*q.v.*) and designed floor and roof loadings.

Load, wind

Loading on a roof, wall, etc., due to wind pressure only.

Mortar

A composition of lime and/or cement and sand mixed with water in various proportions.

Mullion

A vertical member dividing a window frame.

Nails, roofing

A galvanised nail with a mushroom-shaped head used to fix corrugated iron sheets.

Nogging

A horizontal piece of timber fixed between studs in a framed wall.

Orientation

The siting of a house in relation to prevailing weather, air movement, sun exposure and outlook.

Palings

Pieces of rough sawn or split timber, usually about 1 cm thick, used for sheeting, fencing, etc.

Parging

The mortar coating of the internal surfaces of a chimney flue.

Perpends

The vertical joints in a masonry wall.

Pier

A column or post supporting a superstructure such as floor bearers, verandahs, beams, etc.

Pier, engaged

A pier bonded into a wall.

Pier, sleeper

Independent brick, concrete or wooden supports for floor bearers. (See also *stump*).

Pise

Prepared earth rammed between formwork similar to that used for poured concrete walls. This provides monolithic walling. See also *adobe* and *stabilised earth*.

Pitch

The angle of inclination to the horizontal of a roof or stair.

Plate, floor

In brick construction, a timber member continuously supported on brickwork and used to carry floor joists.

Plate, sole

A piece of timber or other material placed on or in the ground to distribute the weight of a vertical load-bearing member.

Plates, wall

In brick construction, timber members placed on brick or other supports to carry the floor joists, and on tops of walls to carry ceiling joists and rafters; in timber framing there are top and bottom plates, which are the top and bottom members of the framed walls.

Plug

A small piece of timber driven into the joints of brickwork or into concrete to form a fixing point for finishing timbers. Many types of metal plugs are also in use in connection with other types of fitting.

Plumb (adj.)

Vertical or perpendicular.

Ply

One layer of a laminated sheet.

Pointing

In bricklaying, the process of filling mortar joints after the construction of the wall.

Puddle (v.)

To consolidate earth by adding water and ramming.

Purlins

In simple roof construction, longitudinal roof timbers giving intermediate support for rafters, supported at intervals longitudinally by struts.

Rafter, common

In roof construction, a timber framing member providing the principal support for the roofing material.

Rail

A piece of timber or metal extending from one post to another, as in fences, balustrades, staircases, etc.; in joinery, framing.

Ram

To compact or consolidate, e.g. the consolidation of earth around fence posts, foundations, etc. See also *puddle*.

Rebate (rabbet)

A step-shaped reduction cut along an edge or face or projecting angle of wood, etc.

Rendering, cement

The covering of a wall surface with one or more coats of cement mortar.

Reveal

The thickness of wall from the wall face to the door or window frame. The remainder of the thickness of wall is known as the jamb.

Ridge

The highest part of the roof of a building at the meeting of the upper end of the common rafters.

Roof, lean-to

See *skillion*.

Sarking

A covering of water-proof building paper or boarding fixed on the top of the rafters, beneath the external roof covering.

Scarfiging

The joining of two pieces of timber together in length by which the two ends are cut to lap over and fit each other.

Screed (n.)

A narrow band of timber or other material applied to a surface as a guide to indicate the correct height or level of the finished work.

Screed (v.)

To bring materials to a true surface by means of a straight edge, using the screeds as a guide.

Section

A drawing showing interior details of a structure, presupposing the building is cut through vertically, so as to exhibit the walls, the heights of ceilings, internal doors and other apertures, the thickness of floors, etc.

Septic tank

Tank used to dispose of sewage when a building is isolated from or cannot be connected to a sewerage system, the sewage being liquefied and purified by bacteria. The excess or overflowing liquid is known as the effluent.

Sill

The horizontal member at the bottom of a door or window frame, etc.

Skillion or lean-to roof

A roof sloping in one direction only with the rafters pitching or leaning against a wall.

Square

Term used to indicate that the surfaces of two faces are at right angles.

Stabilised earth

Prepared earth, to which is added a stabilising agent such as Portland cement or bituminous cold emulsion. Used either in "rammed in situ" or in block construction. See also *adobe* and *pise*.

Stile

The outer vertical member of a framing or panelling, door or window.

Strap

A metal strap such as is used to support a ceiling joist from a hanging beam.

Stretcher

A brick laid with its length along the wall. See *bonding*.

Studs or studding

The vertical members in the wall framework of a timber building.

Stump (pier)

A vertical member of timber or precast concrete sunk into the ground and used to support a floor or wall framework.

Sullage

The waste liquids discharged from all plumbing fixtures excluding water closets and urinals. See *tank*, *septic*.

Termite shield

See *ant capping*.

Threshold

The step or sill of an external door.

Tie

A horizontal member in tension, usually a timber or steel rod binding two members or sections of a building together to prevent spreading. See *tie, collar*.

Tie, collar

A timber member tying a pair of rafters, usually placed midway between the wall plate and ridge (*q.v.*).

Ties, wall

Suitably shaped galvanised wire or galvanised iron straps built into cavity walls to bind the inner and outer leaves; also used in brick veneer construction to bind timbers to the brickwork.

Tongue and groove

A method by which one board is grooved along the edge and the other tongued, so that one fits into the other.

Trap, grease

A trap designed to prevent grease from entering the drainage system.

Trim (v.)

To construct a framed opening in any part of a timber framework.

Trimmer

The timber cross-member inserted when an opening is formed in framework to which the ends of the cut members are fixed. The trimmer itself is fixed between uncut members.

Weatherboards

External wall sheeting formed with overlapping or rebated boards.

Weathering

The sloping surface, e.g. of a sill coping, designed to permit rapid shedding of water.

Weep holes

Openings left in perpendicular joints of a brickwork course over flashings and at the bottom of cavities for drainage purposes.

