

AT MICROFICHE
REFERENCE
LIBRARY

A project of Volunteers in Asia

Simple Solar Still for the Production of Distilled
Water Technical Report No. T17

by: T.A. Lawland

Published by:
Brace Research Institute
MacDonald College
McGill University
Ste. Anne de Bellevue 800
Quebec, Canada H9X 1C0

Paper copies are \$ 1.50. Available in English,
French and Arabic.

Available from:
Brace Research Institute
MacDonald College
McGill University
Ste. Anne de Bellevue 800
Quebec, Canada H9X 1C0

Reproduced by permission of the Brace Research
Institute, McGill University.

Reproduction of this microfiche document in any
form is subject to the same restrictions as those
of the original document.

MCGILL UNIVERSITY

BRACE RESEARCH INSTITUTE

SIMPLE SOLAR STILL FOR THE PRODUCTION
OF DISTILLED WATER

Technical Report No. T. 17

October 1965

Revised September 1967

by

T.A. Lawand

Brace Research Institute
Macdonald College of McGill University
Ste. Anne de Bellevue
Québec, Canada
H9X 3M1

SIMPLE SOLAR STILL FOR THE PRODUCTION OF DISTILLED WATER

by

T.A. Lawand

This is a description of a simple solar distillation unit designed primarily for use in service stations with the object of providing distilled water for automobile batteries. Distilled water is very necessary for battery maintenance, especially in warm and arid regions. The still should produce under normal operating conditions an average of three litres of distilled water per day.

Installation and Operating Procedures

1. Select a site which will assure that the still receives unobstructed sunshine from at least 0800 hours to 1600 hours.
2. Set the still up with the length lined on an east-west axis. As near as possible, the south facing glass should be pointed due south.
3. Level the still as best as possible.
4. The glass need only be cleaned as often as cleaning windows etc., at station, i.e., once every few days. It is recommended that a rubber-stripped type of hand window cleaner be used, with water, to properly clean the glass surface.
5. The still should be filled with clean, fresh water, to a height of approximately 2 cm. Early every morning, about 0700 hours to 0800 hours, the still must be drained of the remaining water, and fresh water added in its place to the specified height.
6. It will be advisable to store the distilled water in a 20 to 30 litre container so that there will be a reservoir for emergencies, etc. Thus surplus distilled water will not go to waste. The area around the reservoir bottle must be kept as clean as possible.
7. During the rainy season, the glass should be properly cleaned before rain storms and the clean rain water collected and added to the reserve stocks. Consequently a constant supply of distilled water will be on hand.
8. When initially starting up the still, reject the first few days of production to avoid contamination.

Always wash out collecting bottles in fresh water and then in distilled water. The collecting bottles must be of sufficient size to hold from 1 to 2 litres.

The tops should be loosely stoppered to prevent contamination.

9. It is essential that cleanliness of the distiller area be maintained at all times to maintain quality distilled water for batteries.
10. Reasonable substitutions in the materials list recommended can be effected to suit the budget and convenience of your particular case.

For inquiries and assistance, please contact:
Mr. T.A. Lawand - Director, Field Operations
Brace Research Institute, Macdonald College
Ste. Anne de Bellevue 800
Québec, Canada

Suggested Method of Assembly of Solar Still

1. Prepare the water tray, solder the joints, and preferably rivet the corners. Paint the tray with a suitable primer and then with a good plastic flat black paint. The paint should be able to withstand continuous immersion and temperatures of 65 to 70 degrees Centigrade, and should not fade or discolour under the influence of the sun's rays.
2. Prior to completion of the painting, the drain pipe should be installed in the indicated location and should extend at least 5 cm. below the bottom of the framework to permit easy installation of the plastic tubing. An eye can be screwed into the frame side above the highest level of the water in the tray and the tubing looped through for easy manipulation.
3. The grooves can be cut in the two side members, for the distillate and rain water troughs and the glass rest. Holes should be drilled for the outlet pipes, the pipes inserted and the edges sealed with caulking. The members should be primed and painted with a good white plastic paint. Care should be taken that the upper face containing the grooves is thoroughly painted to prevent leakage.
4. Assemble the side members, tray support ribs, legs and braces into a framework. The latter two can be pre-painted with white paint.
5. Prepare the angular side pieces, cutting a door in one of them, and the glass support. Both can be primed and then painted with white plastic paint; special care being taken on the inner faces which will be exposed to the still interior. The door must fit tightly.
6. Nail the hardboard insulation retaining sheet in place beneath the tray ribs. The hardboard should be soaked in water for at least twenty-four hours, allowed to dry and then nailed in place. This prevents undulations in the finished assembly. Nail the edges closely to prevent bulging at the seams. Paint the outside bottom face of the hardboard with some aluminum paint.
7. Install the insulation in place, do not pack too firmly but pack evenly and fully. Install the tray in its place, notching out the hardboard to permit passage of the drain pipe. Nail the tray into the framework at about 4 cm. intervals, at the top edges only. Do not nail the tray into the ribs, but only into the side members.
8. Install the angular side pieces and the glass support into the framework. Nail the tray into the side pieces as above.
9. Clean the glass panes extremely well, and install them in place. Care must be taken to avoid finger marks, putty or paint marks on the glass. Caulk the glass well with non-hardening putty (a silicone rubber similar to Dow Corning No. 780 building sealant, is best).
10. Fit several metal or wooden clamps to secure the glass panes to the framework, to avoid their lifting and possible damage during periods of high wind velocity.
11. Install plastic tubing to the trough pipes and be sure to allow sufficient tubing to enter well into the collection bottles. Only thin-necked collection bottles should be used, and the tops should be loosely stoppered around the tubing to prevent contamination of the distilled water.

NOTE: The total materials cost should be about \$8.00 to \$10.00 U.S., and a similar amount should be allowed for labour.

LIST OF MATERIALS REQUIRED

Item	Purpose	No.	Req'd Size	Specifications
A) Galvanized Steel Sheet	Water Tray	1	58 cm x 128 cm	0.3 mm. thick
B) Hardboard Sheet	Insulation Backing	1	60 cm x 122 cm	3 mm. thick
C) Wood Shavings	Insulation		To fill volume 0.3 cubic meters	
D) Glass Panes	Transparent Cover	2	27.5 cm x 122 cm	3 mm. thick, water white
E) Wooden Member	Legs	4	3 cm x 3 cm x 25 cm	Whitewood, or equivalent, finished
F) Wooden Member	Braces	2	2 cm x 4 cm x 60 cm	Whitewood, or equivalent, finished
G) Wooden Member	Braces	2	2 cm x 4cm x 120 cm	Whitewood, or equivalent, finished
H) Wooden Member	Side Members	2	5 cm x 10cm x 120cm	Whitewood, or equivalent, finished
I) Wooden Member	Tray Ribs	3	4 cm x 5 cm x 50 cm	Whitewood, or equivalent, finished
J) Wooden Member	End Pieces	2	17.5 cm x 54.5 cm x 2 cm thick	Cut angular as shown or equivalent
K) Wooden Member	Glass Support	1	2.25 cm x 2.5 cm x 120 cm	Whitewood, or equivalent, finished
L) Copper Tube	Drain Pipe	1	10cm, 1/4 inch tube	
M) Copper Tube	Distillate and Rain water pipes	4	6 cm, 1/4 inch tube	
N) Plastic Tubing	To fit snugly over copper tube		Length variable	Depending on Collection bottles, etc.
O) Non-Hardening Caulking				Similar to that used for steel windows
P) Aluminum Paint				
Q) Primer for Galvanized Steel Surfaces				Preferably 1 coat wash primer and then 1 coat zinc chromate
R) Wood Primer Paint				
S) Black Flat Plastic Paint				
T) White Plastic Paint				
Nails, Screws, Clamps and associated Hardware,				

End View

Figure No. 1.

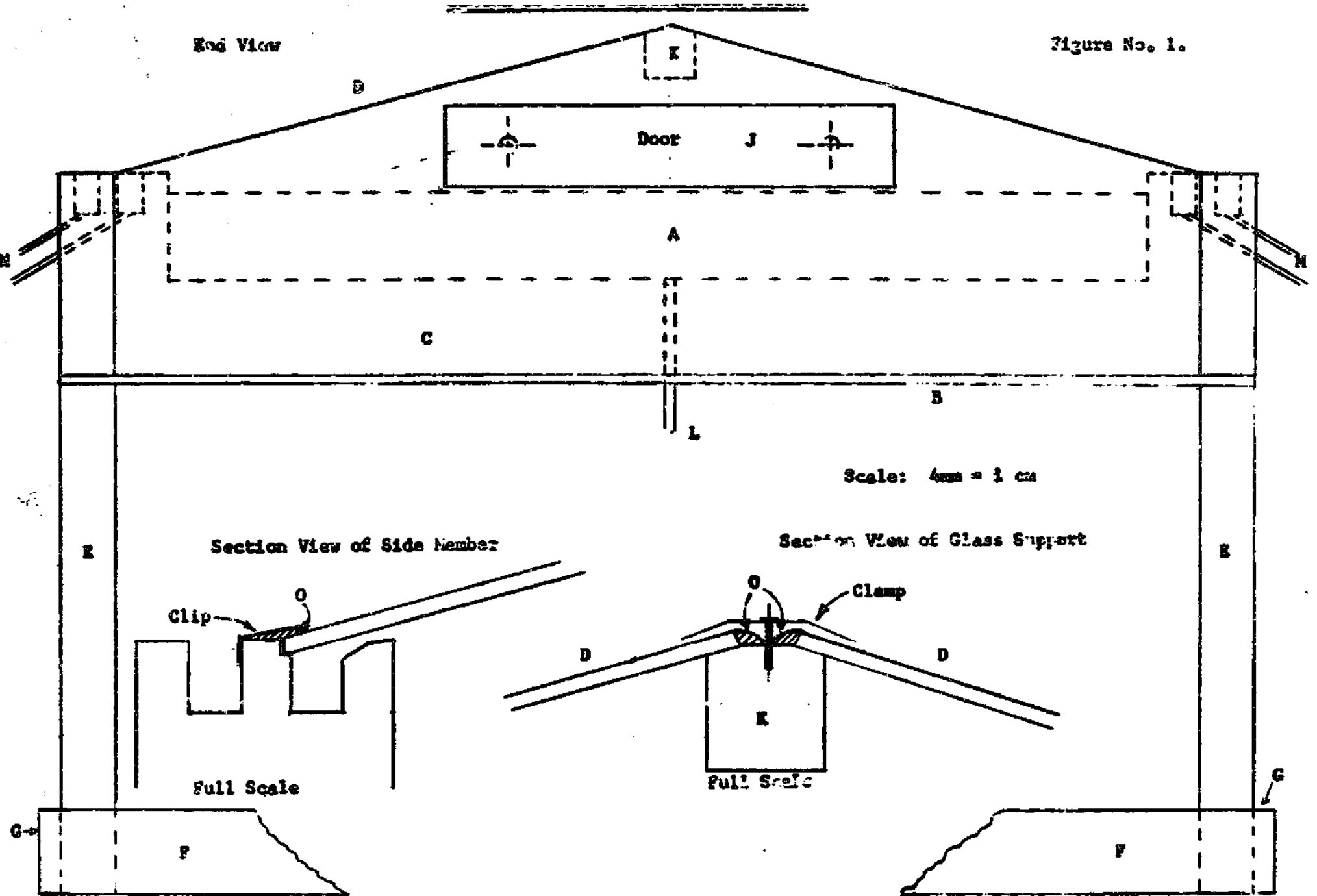

K

Door J

A

C

B

L

Scale: 4mm = 1 cm

Section View of Side Member

Section View of Glass Support

Clip

Clamp

Full Scale

Full Scale

G

F

F

G

Sketch of Solar Distillation Still

Figure No. 2

Plan View

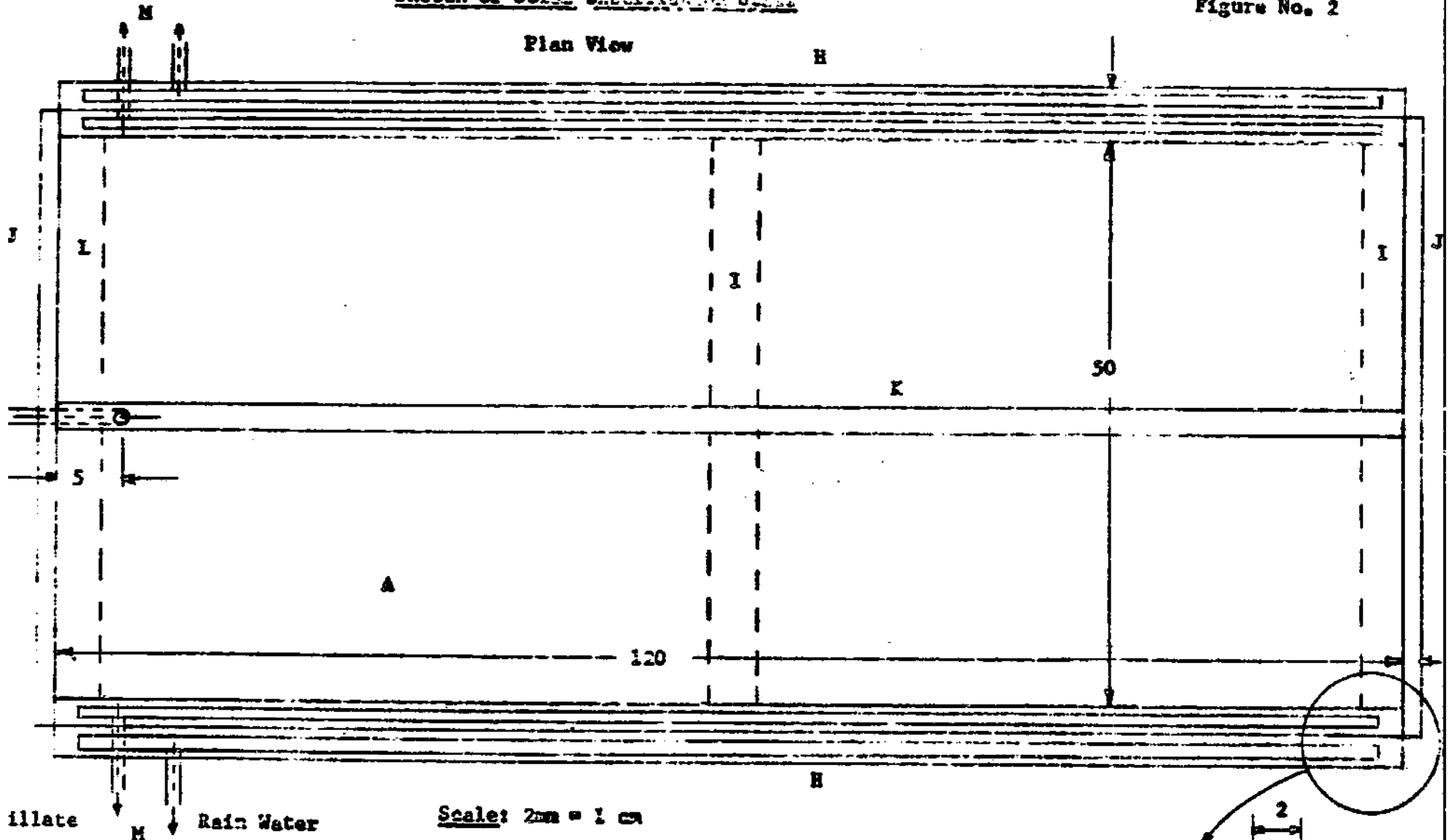

Scale: 2mm = 1 cm

All dimensions shown are in centimeters

Distillate

Rain Water

Troughs

Scale: 4mm = 1 cm

BRACE RESEARCH INSTITUTE
Maccdonald College of McGill University
Maccdonald College, Quebec, Canada

PERSPECTIVE VIEW OF SOLAR STILL
Dimensions Variable to Suit Requirements
of User

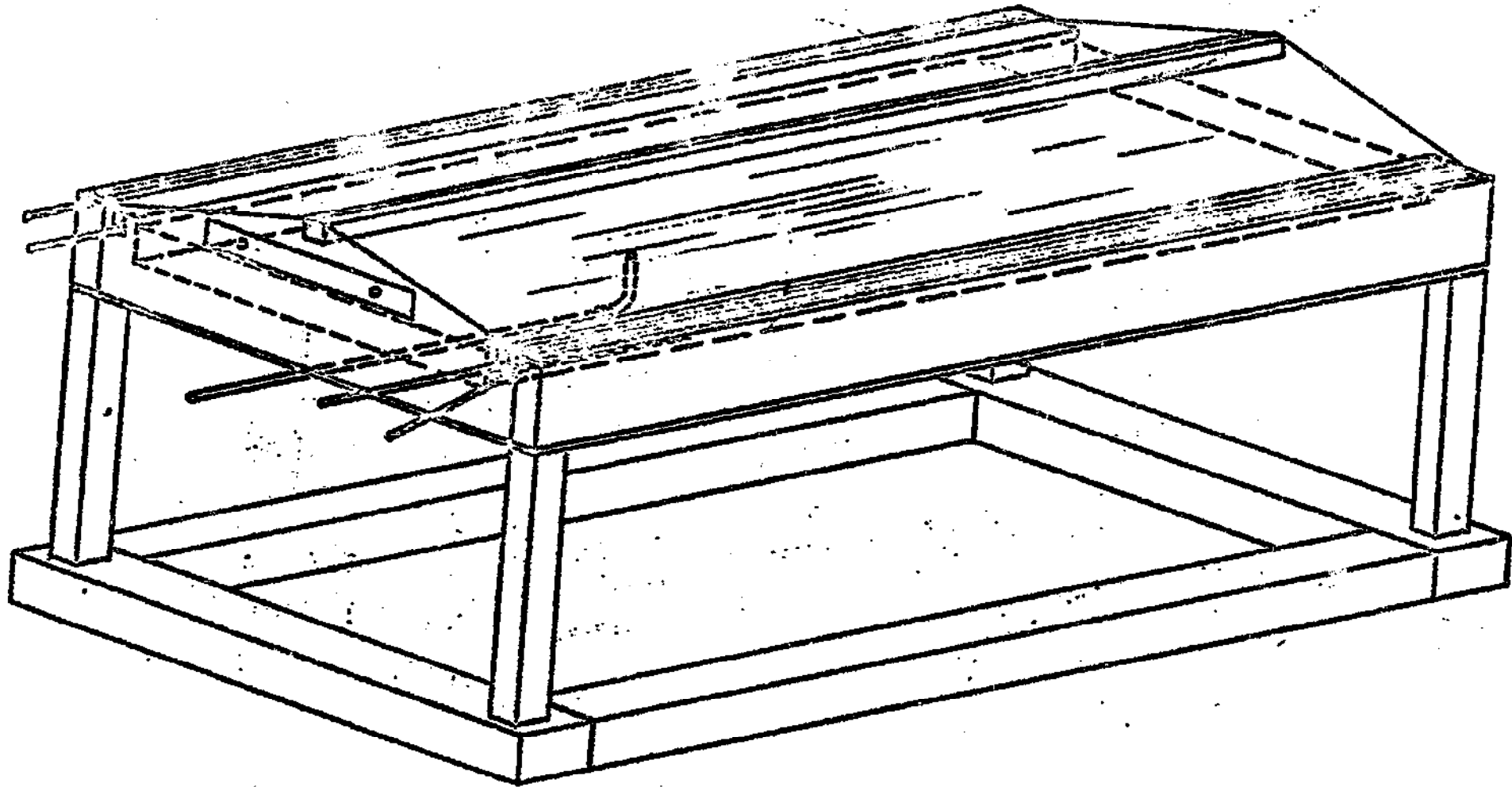

Background Information on the Brace Research Institute

Brace Research Institute of McGill University was founded in 1959 to develop equipment and techniques for making dry lands available and economically useful for agricultural purposes. The Institute has concentrated on the problems affecting individuals or small communities in rural areas and is one of the few organizations with this basic objective.

In general, equipment developed by this Institute utilizes as many local resources as possible, whether human, energy or material, so that the technology can be easily adapted to the local environment. As a result, the Institute has concentrated on utilizing solar and wind energy as well as simple desalination systems, specifically concentrating on the problems that face isolated rural populations in developing arid areas.

Instructional manuals are available describing the use of solar energy for the

- (1) heating of water for domestic and commercial use
- (2) cooking of food
- (3) drying of agricultural produce
- (4) desalination of water for human, animal and agricultural use.

The adaptation of simple greenhouses combined with solar desalination systems for the production of food and water in arid areas is also being developed.

In addition, simple windmills for the production of electricity and the pumping of water have been developed.

Further inquiries should be directed to the

Brace Research Institute,
Macdonald College of McGill University,
Ste. Anne de Bellevue 800,
Québec,
Canada.