

AT MICROFICHE
REFERENCE
LIBRARY

A project of Volunteers in Asia

Lathe Sanders

Popular Mechanics No. X388

by: Dick Hutchinson

Published by:

Popular Mechanics
224 West 57th Street
New York, NY 10019 USA

Paper copies are \$ 0.50.

Available from:

Popular Mechanics Plans, Dept 77
Box 1004, Radio City
New York, NY 10019 USA

Reproduced from Popular Mechanics. (c) The Hearst
Corporation. All Rights Reserved.

Reproduction of this microfiche document in any
form is subject to the same restrictions as those
of the original document.

SHOP NOTES

LATHE SANDERS

By Dick Hutchinson

DO YOU need disk and drum sanders to supplement your belt sander? They can be obtained inexpensively by simply turning a wooden drum to operate between your lathe centers, and a plywood disk to attach to the lathe faceplate or screw center. For the disk sander, you will need a simple table

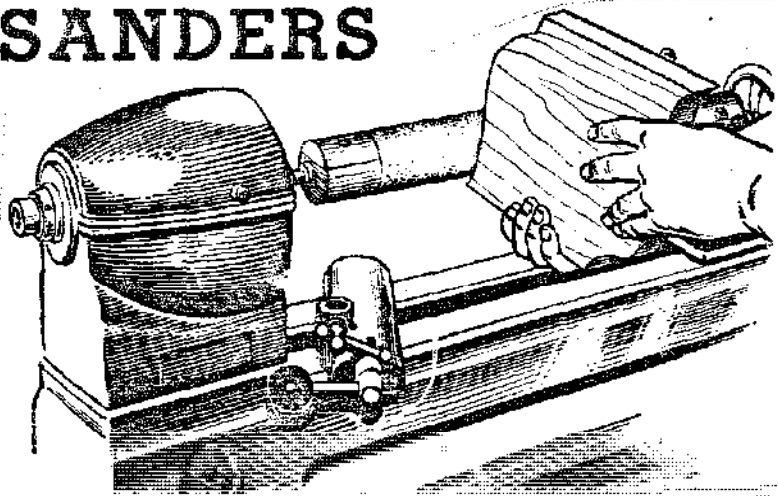

to fit on the lathe ways as in Fig. 3. To make the drum sander, select two pieces of hardwood, one piece 1 in. thick and 3 in. wide, the other 2 in. thick and 3 in. wide. The drum can be any convenient length up to about 15 in. If it is made longer without increasing the diameter proportionately, there is a danger of whipping at high speeds. Glue the pieces together, as in Fig. 1, with a sheet of heavy paper between them. When the glue is dry, mark the center on each end; then mount in the lathe and turn to $2\frac{3}{8}$ in. in diameter. Drill and counterbore each part near the ends for a $\frac{1}{4}$ -in. stove bolt, and then separate the pieces by running a sharp knife blade along the joint. A piece of 1-in. cloth tape attached to one side of the drum over the joint makes a durable, continuous hinge. Cover the drum between the bolt holes with $\frac{1}{16}$ -in. felt, the edges of the felt meeting at the joint. Glue only the ends of the felt to the two parts of the drum, as in the lower detail, Fig. 1. When the hinged parts are drawn together with the bolts, the felt should be tight. Wrap sandpaper around the drum and insert its ends in the opening between the hinged parts. Then tighten the bolts. For best results, the drum should operate at a speed of about 2000 r.p.m. with a medium-grit sandpaper. Fig. 2 shows another

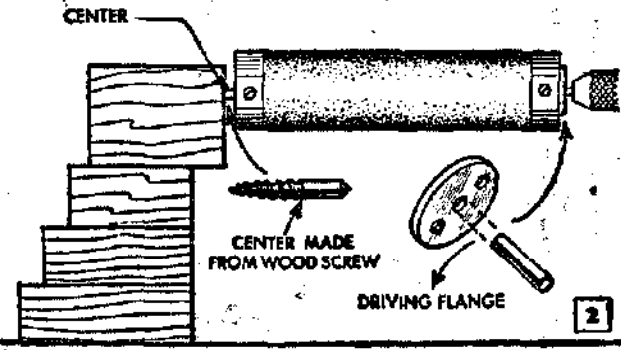
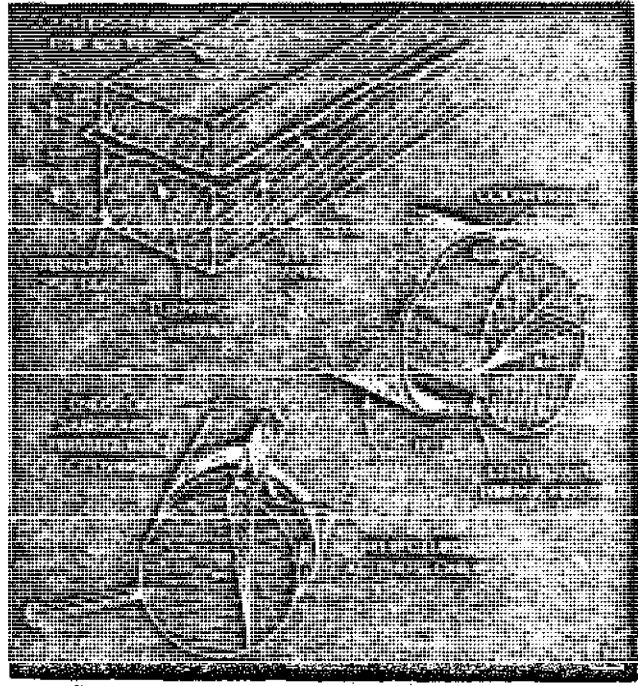

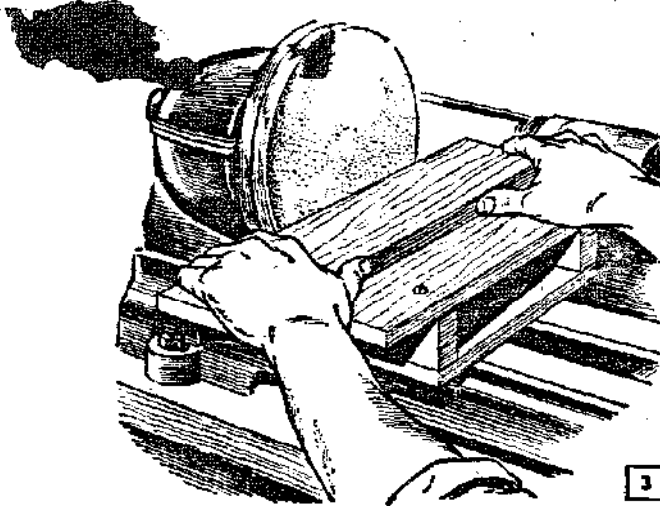

way of operating the same type of drum with an improvised tailstock, driving it with either a polishing head or a small grinder having a threaded spindle on which a drill chuck can be mounted. A driving flange is made by inserting a pin tightly in a small disk cut from $\frac{1}{8}$ -in. sheet metal, Fig. 2. The disk is screwed to the drum end.

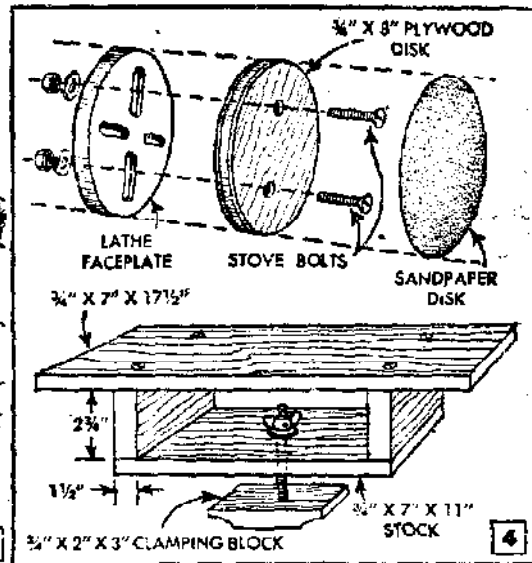

Figs. 3 and 4 show how to make the sanding disk and a table which clamps to the lathe bed. When in position on the lathe bed, the top of the table should be about $\frac{1}{8}$ in. below the center of the disk. This distance is determined by the swing of your lathe. For average small work, a disk speed of 2000 r.p.m. is recommended.

Homemade Blacksmith's Forge Utilizes Old Vacuum-Cleaner Parts

By using the motor and fan assembly of a discarded vacuum cleaner as a blower, in addition to other odd parts, one blacksmith made himself a forge at little cost. The blower is connected to the air inlet and

fastened to one leg of the forge with a flat-iron bracket. The leg bolts are tightened with wing nuts to facilitate removal of the unit when electricity is not available. In this case, of course, a hand-operated blower must be used.

A. M. Morgan, Lafayette, Calif.



Pair of Gloves Kept Together

To prevent one of a pair of work gloves from being mislaid, use snap fasteners to hold the gloves together. This also permits hanging the gloves from a hook or nail.

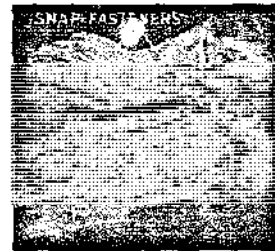

Substitute Thread-Cutting Oil

If you have a rush job to do and run out of thread-cutting oil, any of the following common items may be substituted successfully: melted bacon fat, linseed oil, or turpentine. White-lead-and-oil paint also will serve the purpose, but it is messy to use and must be thoroughly cleaned off.

Howard D. Wildman, Schenectady, N. Y.

X5594

AT MICROFICHE
REFERENCE
LIBRARY

A project of Volunteers in Asia

Scroll Saw

Popular Mechanics No. X594

by: Will Hooper

Published by:

Popular Mechanics
224 West 57th Street
New York, NY 10019 USA

Paper copies are \$ 1.25.

Available from:

Popular Mechanics Plans, Dept 77
Box 1004, Radio City
New York, NY 10019 USA

Reproduced from Popular Mechanics. (c) The Hearst
Corporation. All Rights Reserved.

Reproduction of this microfiche document in any
form is subject to the same restrictions as those
of the original document.

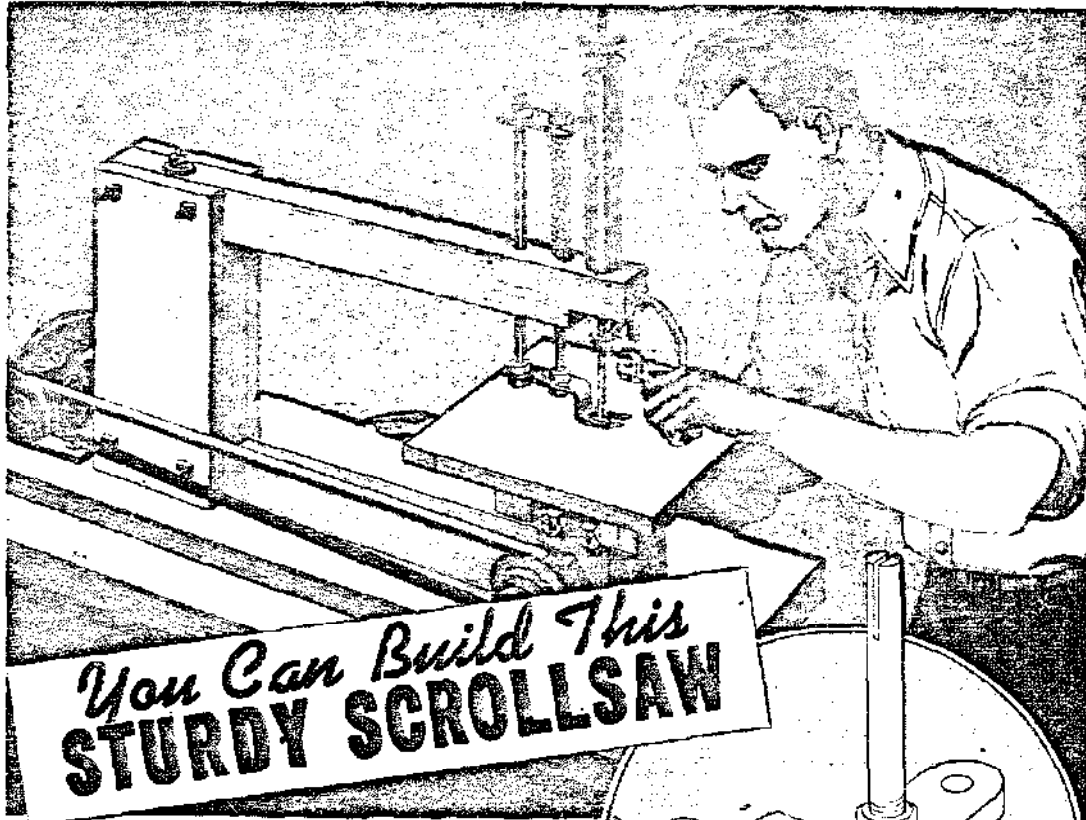
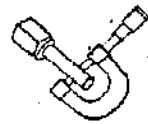

By Will Hooper

THIS scroll saw can be built at small cost from some scrap materials and a few available new items. Begin construction on the crank and drive mechanism. Cut and drill two pieces of well-seasoned hardwood that are smoothly surfaced to net size, Fig. 4. Cut off the threaded portion from two Ford water-pump bushings (Ford part No. B-8520) and, using the pump shaft (No. A-8510) as a driver, force the bushings into the $3\frac{1}{2}$ -in. hole in the 10 $\frac{1}{2}$ -in. block, Fig. 2. You may have to sand the hole a little and taper the ends of the bushings slightly to make them start. Now cut the shaft to a length of 5 or 6 in. and thread one end $\frac{5}{8}$ -in. 18. With a pulley on the shaft, place it in the bushings and put on a lock nut, F, Fig. 7, which is made from a Ford tire-carrier check nut by drilling and retapping it to $\frac{5}{8}$ -in. 18.

Next, from a 1-in. length of $\frac{1}{4}$ -in. iron, make the crank arm, A, Fig. 7, and place it on the shaft flush with the end. Smooth

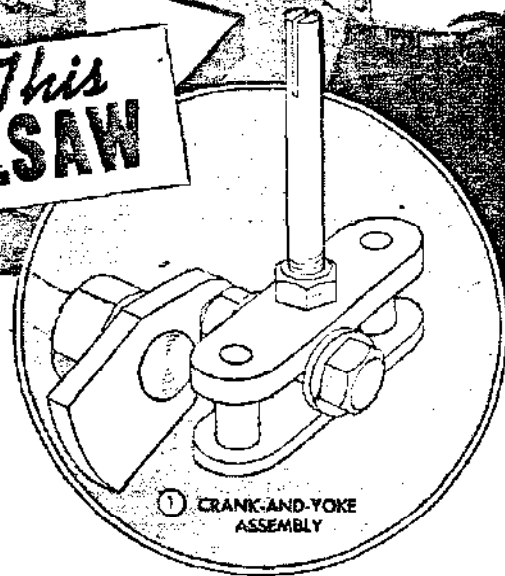

operation of the saw depends upon the accuracy and balance of the crank and yoke assembly, shown in Figs. 1, 5 and 7. Note that the wide end of the crank arm has a tapped hole in which variable counterweights are fitted to get exact dynamic balance. All threaded holes should be straight and true, so a guide must be used to start the taps. The crank pin, C, Fig. 7, is made from a $\frac{7}{16}$ by 2-in. cap screw. This is threaded into the end of the arm, as shown, where it is locked by nut G. The side washers, E, are $\frac{1}{4}$ -in. flat washers drilled out to $\frac{5}{16}$ in. Roller B is a $\frac{1}{2}$ -in.

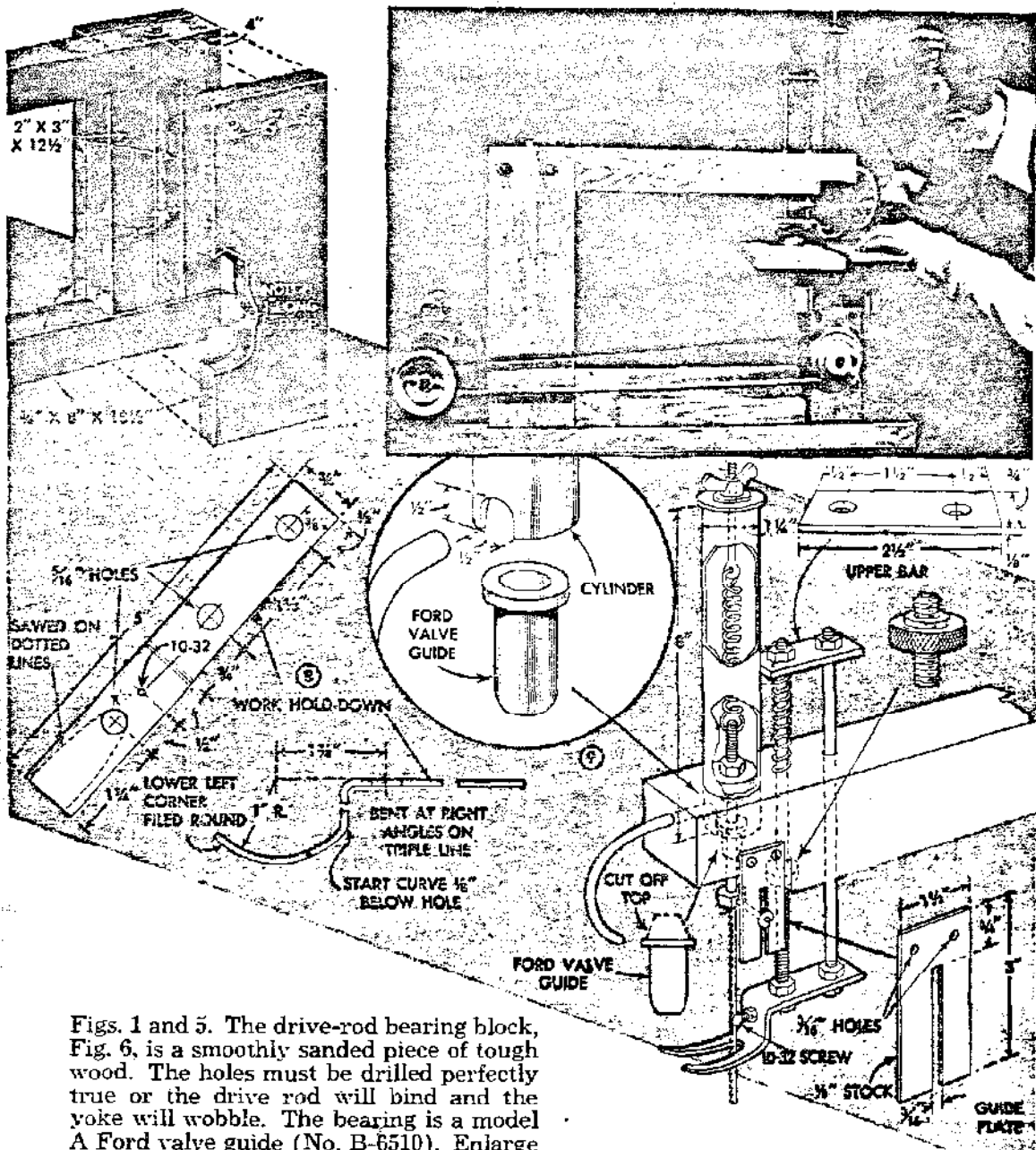

Figs. 1 and 5. The drive-rod bearing block, Fig. 6, is a smoothly sanded piece of tough wood. The holes must be drilled perfectly true or the drive rod will bind and the yoke will wobble. The bearing is a model A Ford valve guide (No. B-6510). Enlarge the hole slightly by reaming or sanding, but leave it small enough so that the bearing cannot be pressed into it by hand. Coat the wall of the hole with cement and press the bearing in, turning it so that the slits are at right angles to the lubricant duct. Then, using the duct as a guide, drill a $\frac{7}{16}$ -in. hole through one side of the bearing.

Figs. 3 and 9 show the over arm. If you use a Ford tire-pump barrel for the saw-dust-blower cylinder, which is shown in Fig. 9, bore a $1\frac{1}{4}$ -in. hole, $\frac{3}{4}$ in. deep, in the 2-in. face at a point 2 in. from one end. Continue on through with a $\frac{1}{16}$ -in. bit. Then saw out a 1 by $2\frac{3}{4}$ -in. notch in the lower side. Enlarge the $\frac{1}{16}$ -in. hole to take

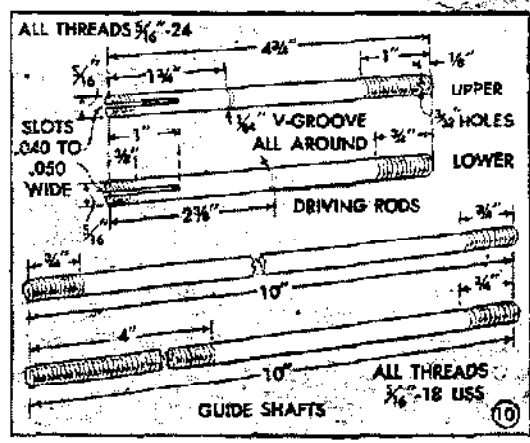

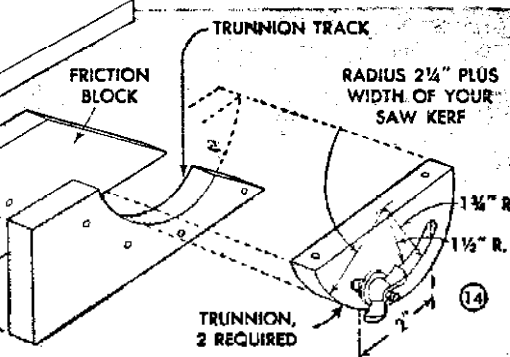
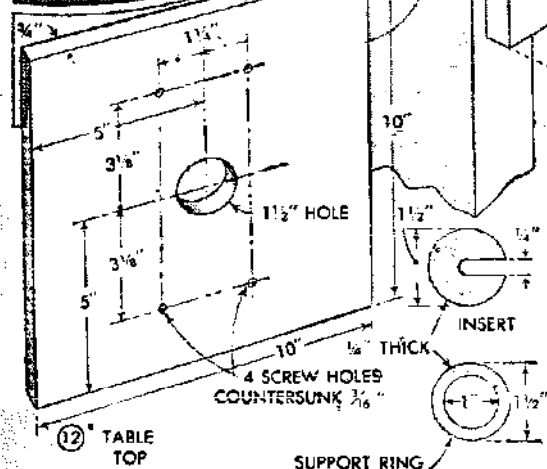
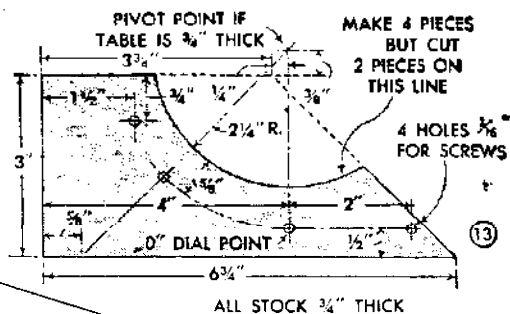
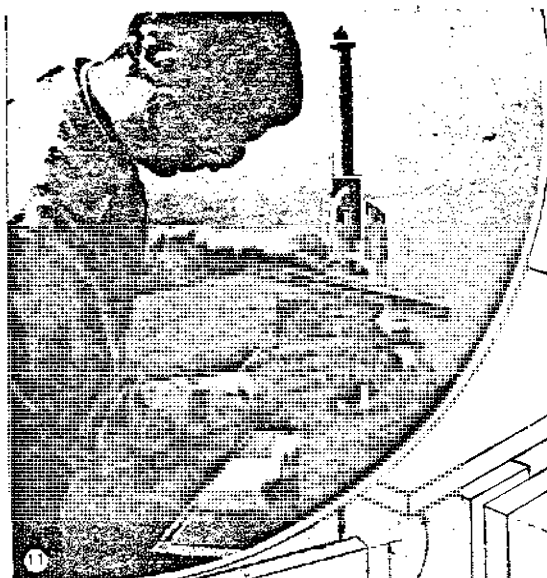

a Ford valve guide, shown in the circular detail, Fig. 9. Drill a $\frac{19}{64}$ -in. hole 2 in. deep in the end of the arm to serve as an air duct for the sawdust blower and drill a $\frac{3}{16}$ -in. hole 1 in. deep in the left side for lubrication. Next, drill two $\frac{3}{16}$ -in. holes for the hold-down guide shafts, which are shown in Fig. 10. These, and the hole for the bearing, must be perpendicular to the arm and parallel with each other. To make the upper-rod bearing, cut off the short end of a Ford valve guide against the flange. When this is installed, use the grease duct as a guide and drill a $\frac{3}{16}$ -in. hole through one side. Complete the frame by making the base arm, the two rear support posts and the two side clamping plates, and assemble these as in Fig. 3. The horizontal holes in the over arm should be drilled after the machine has been run and the stay rod retightened, using the side plates as a guide for the bit.

The work hold-down and blade guide are shown in Fig. 8. The knifed wheel shown

in Fig. 9, by which the hold-down is adjusted, is a Ford windshield-wiper thumb nut (No. B-45482). This is threaded $\frac{3}{16}$ -18 like the guide shaft on which it is screwed. The compression spring should be just large enough to slip over the rod and strong enough to have a 2 or 3-lb. lift when the hold-down is in top position. Use a No. 10-32 screw and lock nut for the blade guide. The regular slot in the screw is suitable for medium and heavy blades and you can saw a slot crosswise to it for finer blades.

For the blower, use a tire pump with a $1\frac{1}{4}$ -in. outside diameter. After enlarging the holes in the plunger valve and washers to $\frac{7}{16}$ in. and placing them on the upper drive rod, insert the rod in a bearing in the over arm. The tension spring, which is held by a 2-in. eyebolt, should be well tempered and about half the size and strength of a screen door spring. To complete the blower, a piece of $\frac{3}{16}$ -in. copper tubing is bent and fitted into the air duct so it will direct an air blast toward the work. Now make the upper-rod guide plate and attach it to the over arm so that the slot will be in line with the rod. This part is necessary only if there is a tendency for the blade to twist. Two blade chucks are made from $\frac{3}{16}$ -in.-24 nuts by drilling through the side and tapping for No. 10-32 setscrews. The screw for the lower chuck should be $\frac{1}{4}$ in. long, while the upper one is 1 in. long so that it will pass through the slot in the guide plate. Install $\frac{1}{4}$ -in. threaded grease fittings in the lubricant ducts and use auto-wheel bear-

ing grease. Unrefined petroleum jelly is a suitable substitute for auto-wheel bearing grease and a small jar will last for a long time. On the rod bearings, lubricating is done best while the machine is running slowly.

To make the tilting table, cut out the two friction blocks, Figs. 13 and 14. From two more blocks exactly like these make the trunnion tracks by sawing on the curved line, as in Fig. 13. When laying out this curve, bear in mind that the pivot axis is actually outside the trunnions at a point halfway through the table. Thus, if your table top is to be $\frac{3}{4}$ in. thick, the stationary point of your compass must be $\frac{3}{8}$ in. outside or above the piece being marked, otherwise the tilting axis will not be correctly placed. To get the correct radius for the trunnions, add the width of your saw kerf to the radius used in cutting them. If you use the same radius in both cases, the tracks will be larger than the trunnions, resulting in improper fit. Drill through each trunnion slot with a $\frac{1}{2}$ -in. bit, making a hole through both friction blocks so that the bit will just miss the left upright post. Then insert a $\frac{1}{4}$ by $7\frac{1}{2}$ -in. carriage bolt through these holes, with a washer and wing nut on the front end.

Fig. 12 shows the top of the table, for which plywood is suitable. Countersink the screw holes so they will fit flush or slightly below the surface. The insert and support ring should be sawed from $\frac{1}{4}$ -in. plywood or hardwood. The insert should go into the hole with a free fit, but the supporting ring must be a press fit. When mounting the table top on the trunnions, use paper shims if necessary to align it squarely with the saw blade. One of the trunnion-track mounting screws is on the zero dial point and one is on the 45-deg. point. Fasten a pointer, made of bright tin, on the front trunnion at the center line. Then, with a protractor, locate the 15 and 5-deg. points, indicating them with smaller screws. If the trunnions have a tendency to roll on the tracks, you can steady them by running two tension springs from the locking bolt to screws set in the lower side of the table top at the center line.

A $\frac{1}{4}$ -hp. motor will pull this machine satisfactorily, using a $\frac{3}{8}$ -in. V-belt and regular stock V-pulleys. The ordinary stock sizes of step pulleys are not suitable for use in pairs, as they give speed variations that are too great. A good combination is a 2-in. pulley on the motor and a 4-step pulley on the saw, with pulleys of $4\frac{1}{2}$, $3\frac{3}{4}$, 3 and $2\frac{1}{4}$ -in. size. Of course, either the motor or the saw must be movable. If an endless V-belt of the proper length is not available, $\frac{3}{8}$ -in. round leather belting can be used satisfactorily.

Roll of Corrugated Cardboard Is Fed Through Slot in Bench

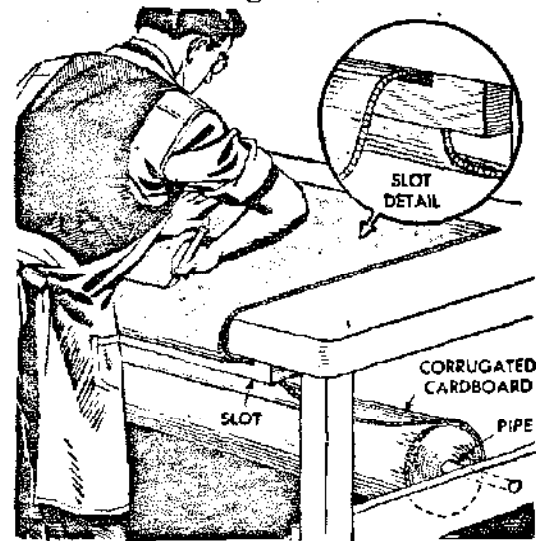

Packers and others who use corrugated cardboard at a bench will find this method of handling it very convenient. The roll of cardboard is mounted on an axle under the bench and is fed up through a slot at the edge of the bench. In this way, the cardboard is pulled up on the bench top and the required amount cut off, after which the severed end of the roll hangs free, close to the slot within easy reach. The slot is made by recessing one side of a wood strip of suitable length and screwing it to the underside of the bench top, making the recess just deep enough to provide a slot.

Gordon B. Dart, Hartford, Conn.

Hens' Nests With Wire Bottoms Are Easy to Clean

Sanitary nests for hens are easy to make by simply constructing wooden frames and fitting them with bottoms of poultry wire. Covering the wire with old newspapers keeps the nesting material from falling through the wire. To clean the nests, simply dump out the paper and nesting material and replace it. The wire provides no corners or crevices for vermin.

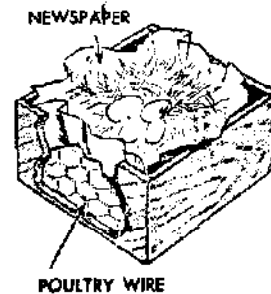

Jack Bronte, Grass Valley, Calif.

❑ A blotter or other sheet of paper placed under an office stapler or any heavy object will effectively prevent it from marring the surface of a desk.

X334

AT MICROFICHE REFERENCE LIBRARY

A project of Volunteers in Asia

Motorize Your Hacksaw
Popular Mechanics No. X334

by: Carl S. Bates

Published by:
Popular Mechanics
224 West 57th Street
New York, NY 10019 USA

Paper copies are \$ 0.50.

Available from:
Popular Mechanics Plans, Dept 77
Box 1004, Radio City
New York, NY 10019 USA

Reproduced from Popular Mechanics. (c) The Hearst
Corporation. All Rights Reserved.

Reproduction of this microfiche document in any
form is subject to the same restrictions as those
of the original document.

SHOP NOTES

MOTORIZE YOUR HACKSAW

By
Carl S. Bates

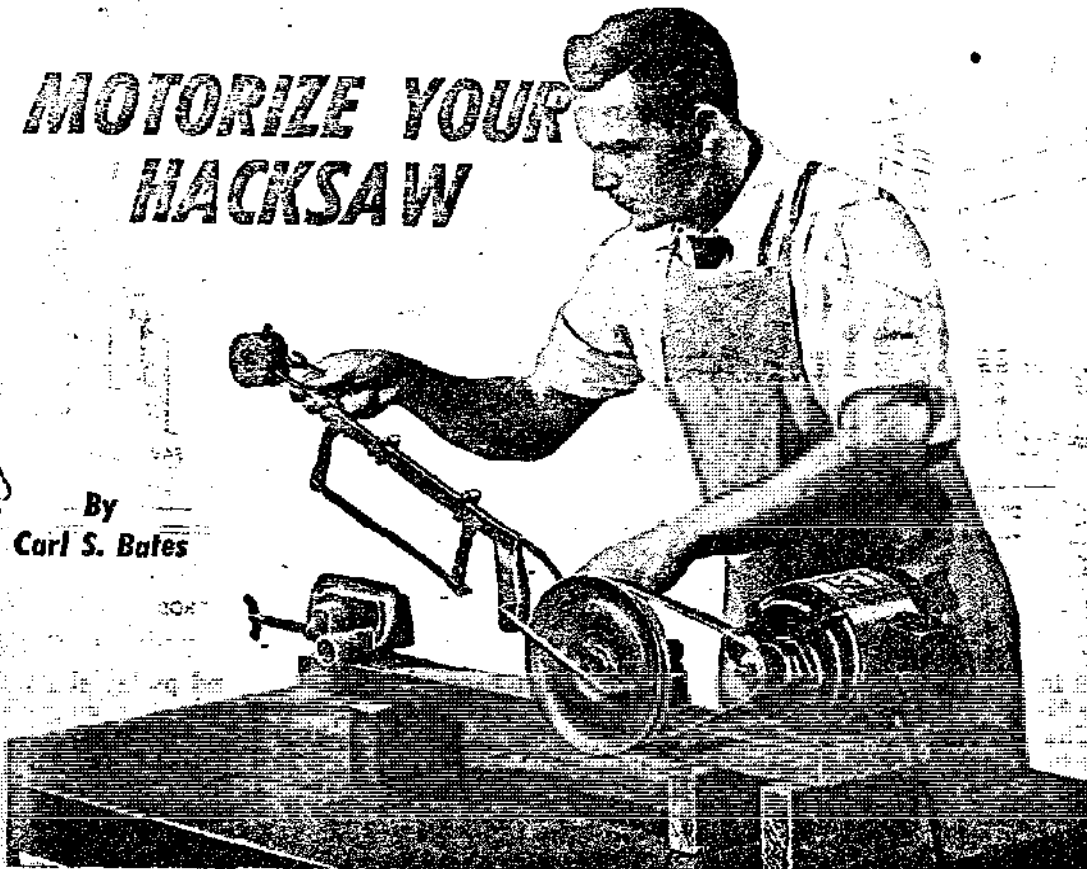

IF YOU HAVE a small metalworking shop or use steel bar or shafting to some extent in your home workshop, motorizing a hand hacksaw will save hours of work and can be done at a fraction of the cost of a commercial power hacksaw. The inexpensive drive unit consists of an 8 or 10-in. V-pulley and shaft, a connecting rod and a guide rod, a vise or clamping arrangement to hold the work and a suitable wooden base. When needed for handwork, the saw can be removed from the unit in a few minutes. As pictured above, a separate motor may be used to drive the saw. However, to cut costs, the saw also may be driven by means of a pulley and shaft chucked in a metalworking lathe, or for light work, even by a $\frac{1}{4}$ -in. electric drill.

The detail on the following page shows the drive unit mounted on a portable wooden base which, of course, will vary depending upon the particular installation required and the means by which the unit is

driven. An 8-in. cranking pulley is recommended if the saw is driven by a low-speed motor or by lathe power. In the latter case, a 2 or 3-in. pulley is mounted on a $\frac{1}{2}$ -in. shaft which is chucked in a metalworking lathe, and the wooden base is bolted to the lathe bed under the chuck. If a $\frac{1}{4}$ -hp., 1725-r.p.m. motor is used, it is best to drive a 10-in. cranking pulley with a $1\frac{1}{2}$ -in. pulley on the motor shaft. Should you use a 10-in. cranking pulley, increase the connecting-rod length to 8 in.

When mounting the pillow blocks for the cranking-pulley shaft, space them far enough apart to allow clearance for the anchor block of the guide rod. The shaft also should clear the top of the wooden mounting block sufficiently to allow the anchor block to rock back and forth as the saw is raised and lowered. Dimensions given in the detail are for a steel anchor block. This part also can be made of hardwood, but the $\frac{3}{4}$ -in. thickness then should be increased

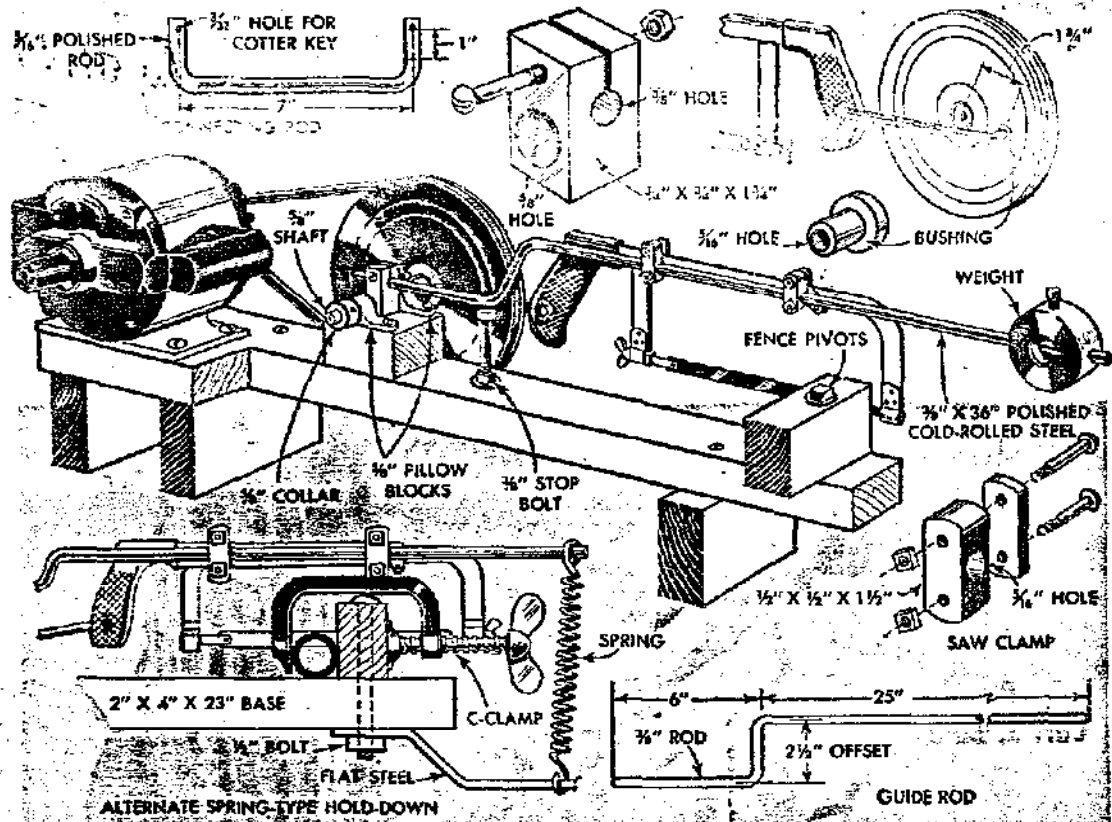

to 1 in. to leave heavier walls after drilling the $\frac{5}{8}$ -in. shaft hole.

The two saw clamps are made of steel or hardwood and should slide smoothly along the guide rod. Saw pressure is brought to bear on the work by means of either a movable weight or a spring-type hold-down. Adjusting the weight or using springs of different tension will vary the pressure to suit the thickness and hardness of the work. Too much pressure as well as speed may draw the temper and quickly dull the teeth.

Both the pulley and the hacksaw handle are drilled and bushed to receive the ends of the U-shaped connecting rod which are held in place with cotter keys. A short length of tubing will do for the saw-handle bushing. When drilling the pulley for the bushing, be careful to drill the hole parallel with the shaft hole, as the connecting rod

will bind if the bushing and pulley shaft are not parallel. To prevent vibration, counterbalance the pulley with a 4-oz. piece of flat steel fastened to the inside of the pulley, locating the weight 2 in. from the center of the pulley and directly opposite the connecting-rod bushing.

The guide rod should be set square with the pulley shaft to prevent binding, and because of the $2\frac{1}{2}$ -in. offset in the rod, squaring is done easily by turning the rod in the anchor block and reclamping. The work to be cut is held in a drill-press vise or a simple vise improvised by bolting a wooden block to the base and clamping the work against the block with a C-clamp. Note that this block can be set at various angles.

Best results are to be had by setting the blade to cut on the pull stroke, the length of stroke being about $3\frac{1}{2}$ in. ★★★

Adjustable Curve for Home Shop Improvised From Hacksaw Blade

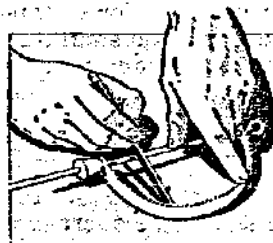

Having several short arcs of different radii to scribe on a sheet of plywood, I found that an adjustable curve for this type of work could be formed from a

standard hacksaw blade and a length of stiff wire. The wire was bent at one end to keep the blade from slipping off, and then passed through the holes in the ends of the blade. By sliding a cork, which was impaled on the wire, against the end of the blade, I was able to change the arc as necessary for the particular layout work.

G. E. Hendrickson, Argyle, Wis.

x37

AT MICROFICHE
REFERENCE
LIBRARY

A project of Volunteers in Asia

Two-Speed Bandsaw Cuts Wood and Metal
Popular Mechanics No. X37

Published by:
Popular Mechanics
224 West 57th Street
New York, NY 10019 USA

Paper copies are \$ 1.75.

Available from:
Popular Mechanics Plans, Dept 77
Box 1004, Radio City
New York, NY 10019 USA

Reproduced from Popular Mechanics. (c) The Hearst
Corporation. All Rights Reserved.

Reproduction of this microfiche document in any
form is subject to the same restrictions as those
of the original document.

TWO-SPEED Cuts Wood

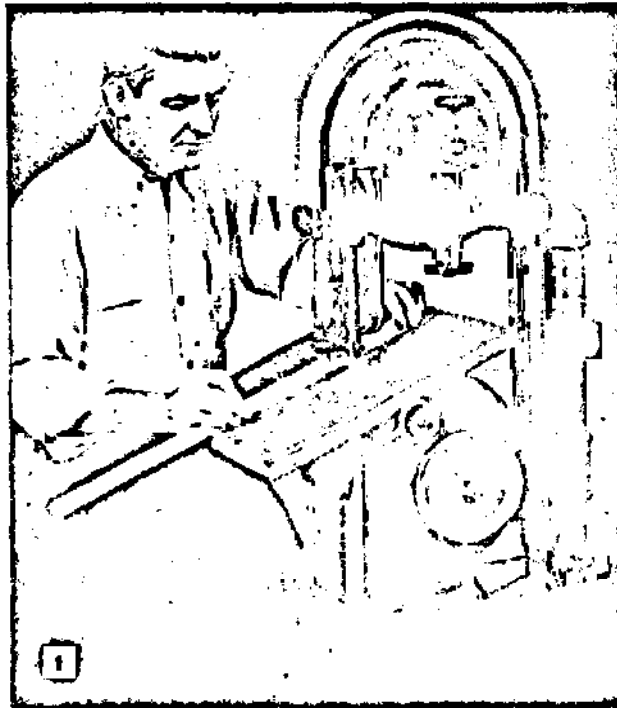

THIS BANDSAW for cutting wood and metal is a home-built unit throughout, yet it has every essential feature of the average dual-purpose-type machine. The frame is assembled from pipe and fittings, band wheels are made from hardboard for lightness and strength and are mounted on ball bearings. The table tilts on double trunnions, Fig. 1, and the upper wheel-bearing assembly is fitted with a spring-loaded blade-tensioning-and-tracking device. The necessary speed reduction for metal cutting is made through

37

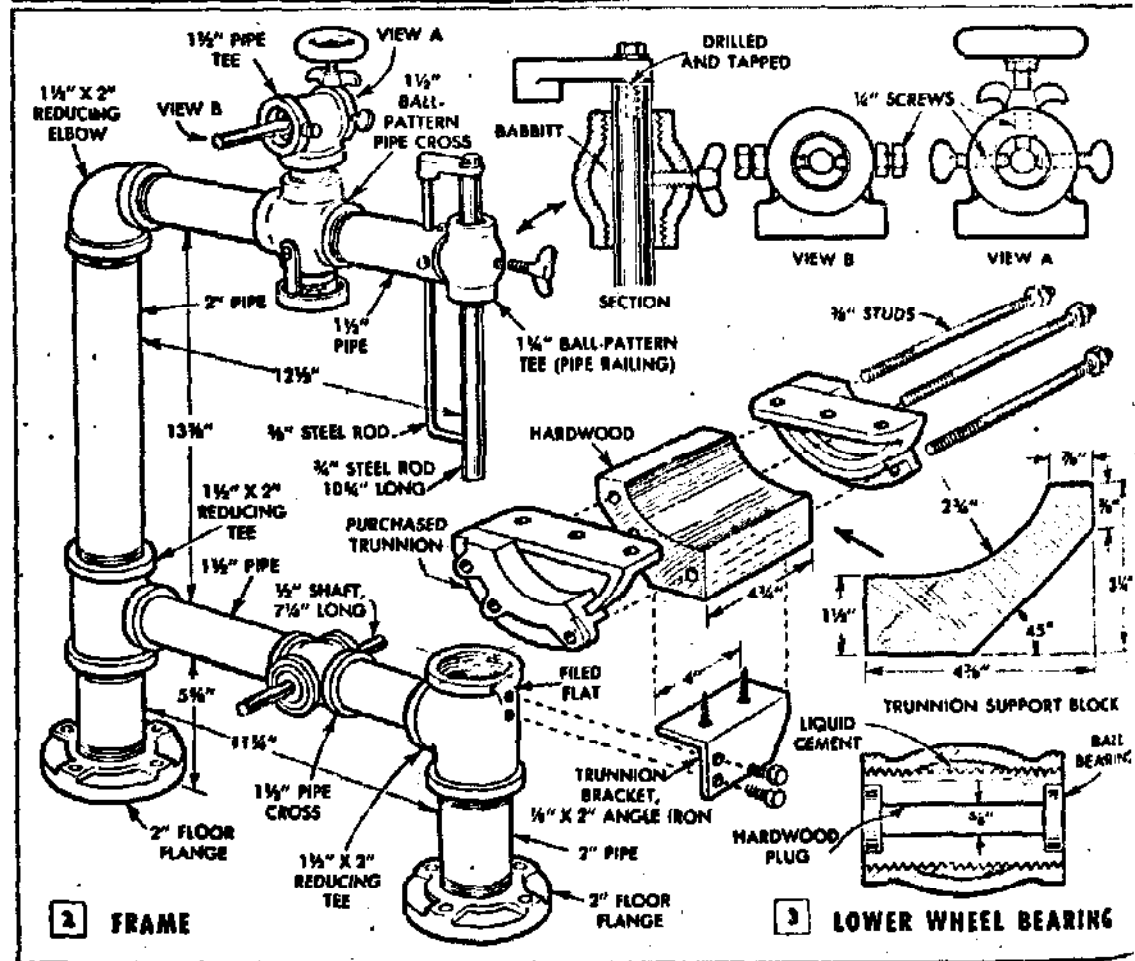

Dec 50, 204 * Jan 51, 215

BANDSAW and Metal

two step pulleys on a jackshaft mounted in a base which has been especially designed and built to reduce vibration to the minimum. A simple belt shift to direct drive provides the higher speeds necessary for cutting wood. Note the trim, neat design of the machine in Fig. 4.

Fig. 2 details the frame and Fig. 3 the lower wheel-bearing and the trunnion assembly. Long and short pipe nipples, reducing elbows, tees and floor flanges are assembled to form the frame shown in Fig. 2. One thing to note especially at the outset: You will see in Fig. 2 that the over-all dimensions are given from side to side and not from center to center. In detailing an assembly of this type made from pipe fittings it is not possible to give precise center to center dimensions. Those given represent the distances on the original assembly with the threaded joints drawn moderately

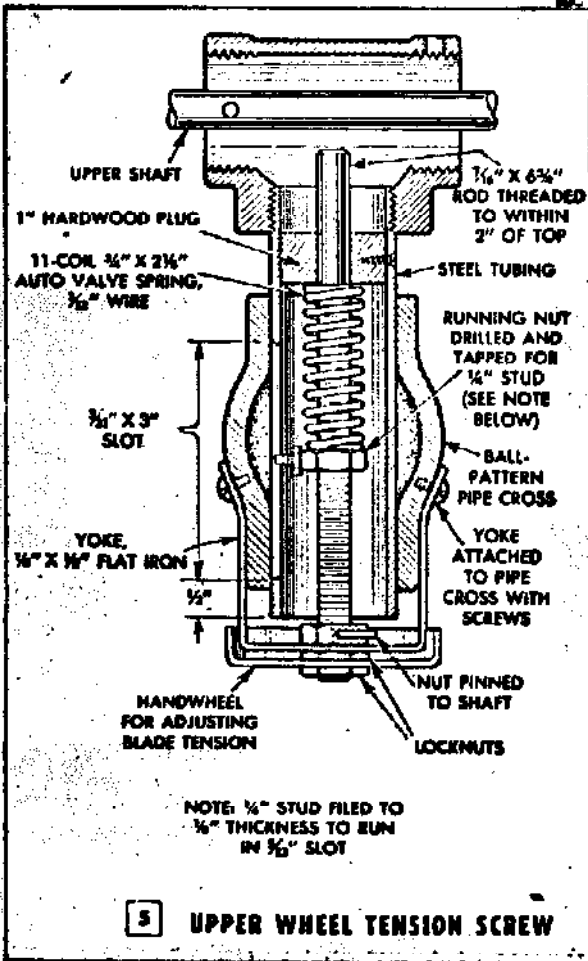
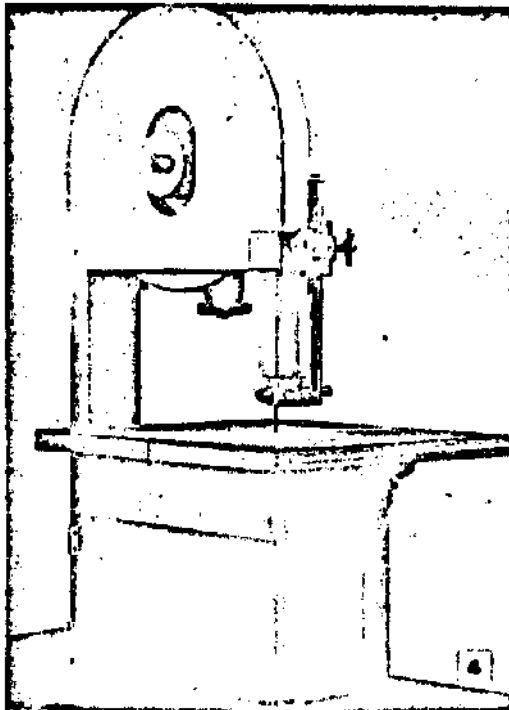

tight. Because of slight allowable variations in threading and tapping pipes and fittings, frames built up in this way from a number of fittings may vary somewhat in over-all size. Probably the best procedure is to make a trial assembly, drawing each of the joints as nearly as possible to the same tension. Then check the dimensions. If actual measurements are slightly over or under, it usually is possible to correct the error by tightening or loosening several joints.

Note in the frame assembly, Fig. 2, that the blade-tension unit is fitted into a ball-pattern pipe cross, and also that the steel rod, which supports the upper blade guide, slides in a bearing formed by pouring molten babbitt into a ball-pattern pipe tee. Views A and B, Fig. 2, show opposite ends of the pipe tee which houses the wheel-tilting mechanism. At the inner end, next to the wheel hub, the spindle pivots on two pointed set-screws provided with jam nuts. At the opposite end two horizontal set-screws bear against the spindle to prevent lateral movement. The spindle is tilted by a vertical screw fitted with a wing nut for locking the adjustment. This assembly is supported on a short length of steel screw fitted at one end and turned, or ground, to a sliding fit in the pipe

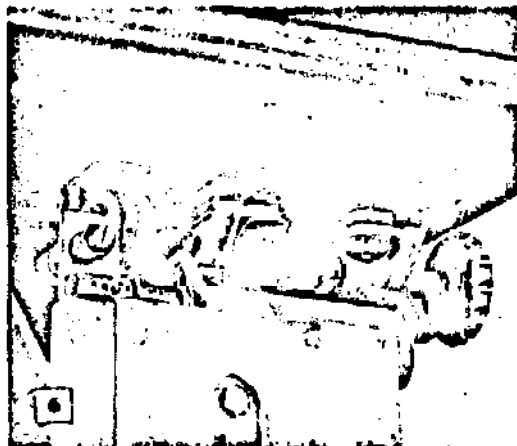

6
 Lower trunnions and lower guide in place on the band-saw frame. Note that table is recessed for clearance

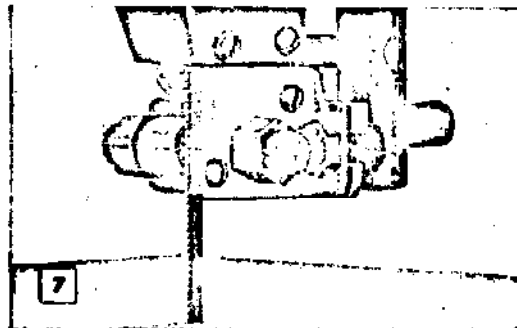

7
 Above and below are views of the upper blade guide completely assembled and with the blade in position

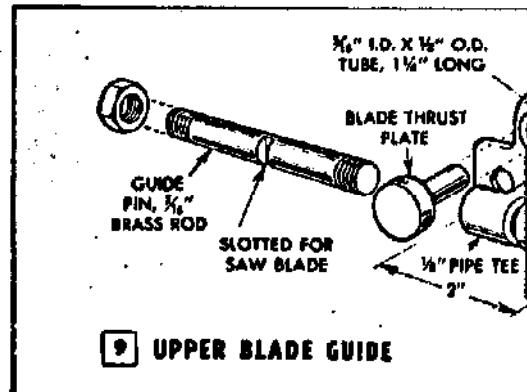
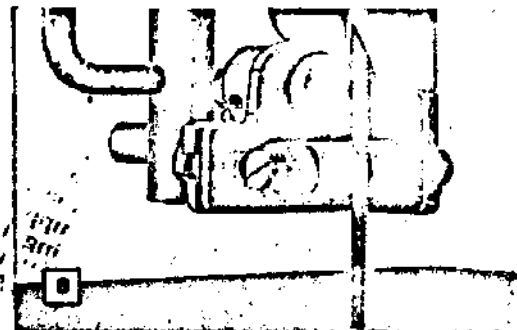

9 UPPER BLADE GUIDE

cross. The threads in the pipe cross are reamed out as in Fig. 5. A hardwood plug, forced into the upper end of the tube and fastened with three wood screws, forms a bearing for the upper end of the tension spring. The running nut which bears against the lower end of the spring is prevented from turning by a short stud which turns into a tapped hole in the nut. Flats are filed on the opposite end of the stud permitting it to enter a $\frac{3}{16}$ -in. slot cut in the wall of the tubing. The stud is provided with a jam nut to hold the adjustment securely. The lower end of the tension screw is fitted with a handwheel and is supported by a flat-iron yoke bent to a U-shape and attached to the pipe cross with short cap screws. To give ample range of adjustment of the upper wheel, the $\frac{3}{16}$ x 6 $\frac{3}{4}$ -in. tension screw is threaded to within 2 in. of the top end as in Fig. 5.

Construction of the lower wheel bearing is easily worked out from the detail in Fig. 3. The double trunnion, which is purchased, is quite simple to assemble by following the upper details in Fig. 3. Note that a flat is filed on one side of the reducing tee at the front of the frame and that two holes are drilled and tapped for cap screws which hold the trunnion bracket. The trunnion must be assembled completely before attaching to the frame. An underside view of the trunnion is given in Fig. 6. The locking handwheel has a threaded sleeve that is turned onto a stud which passes through a hole drilled through the two halves of the outer trunnion. One of the halves of this trunnion is slotted to permit the table to tilt 45 deg. forward.

Two views of the upper blade guide are shown in Figs. 7 and 8, and the assembly is detailed in Fig. 9. The first thing to note in Fig. 9 is the relation of the slotted angle-iron mounting pad to the rest of the parts

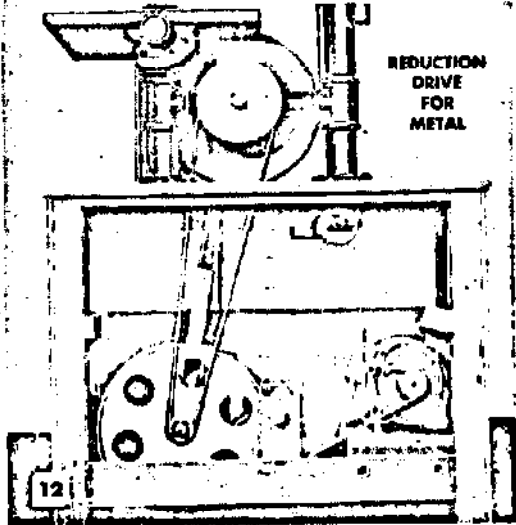
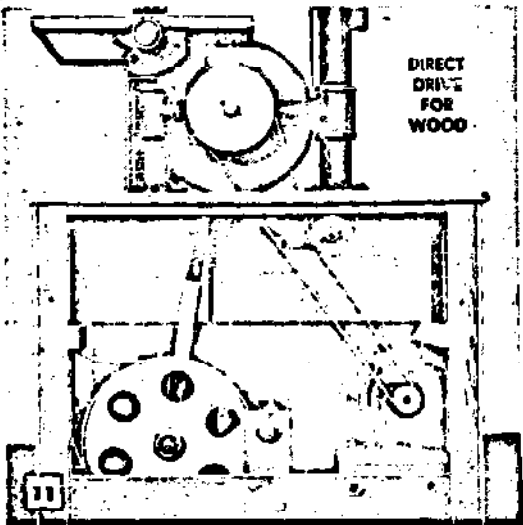
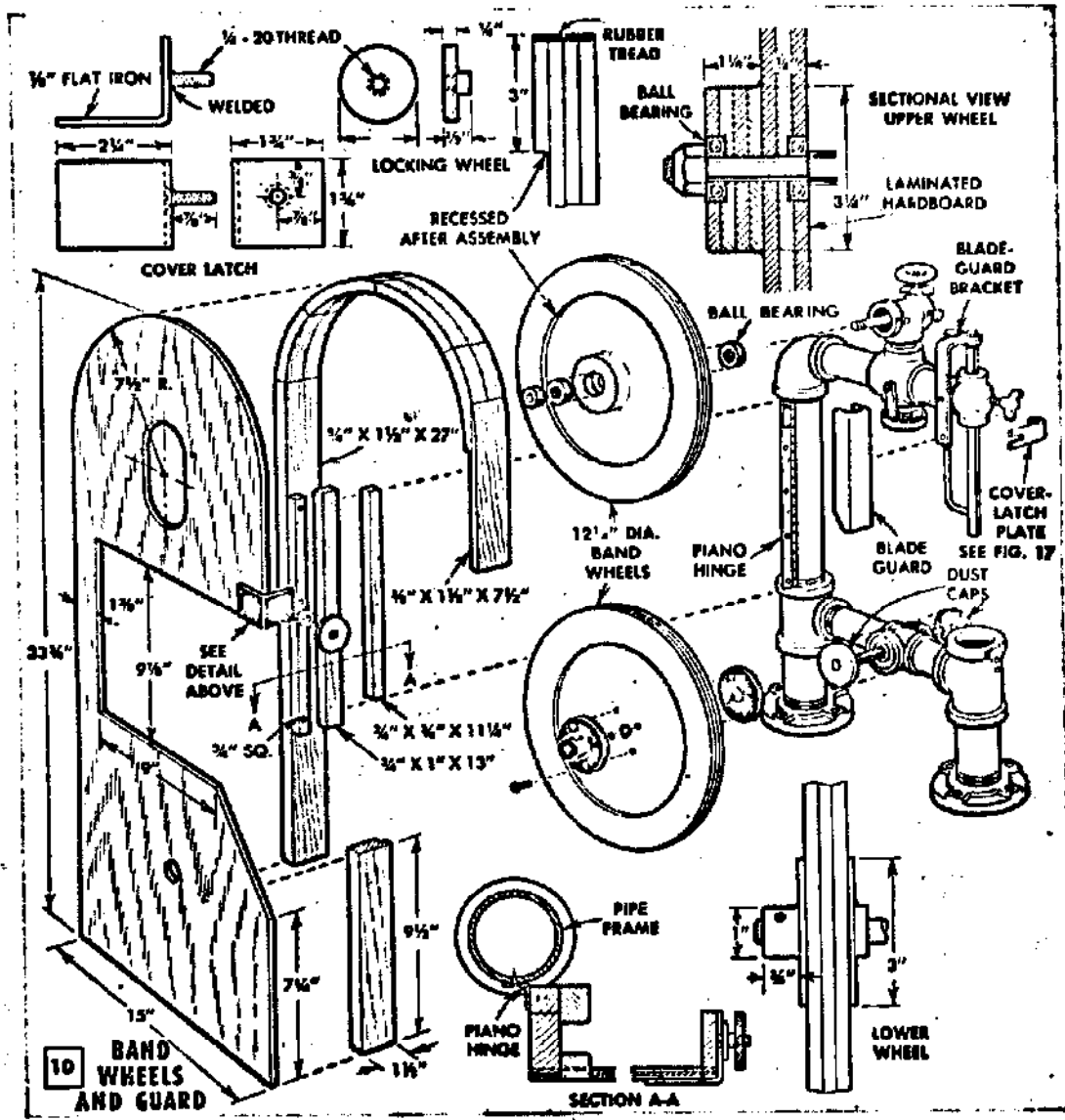

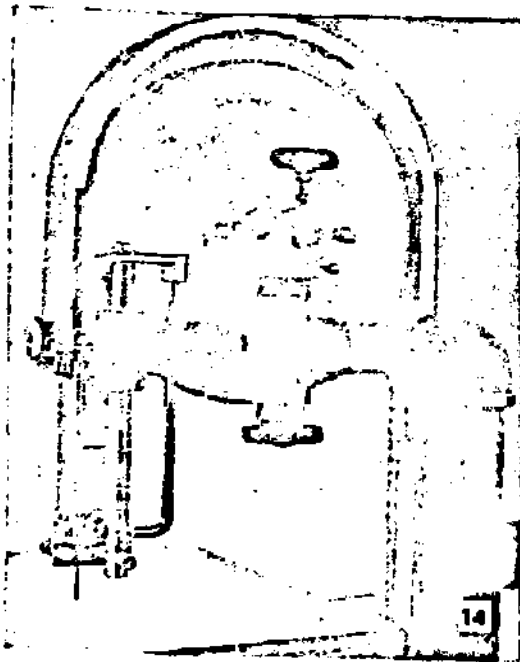
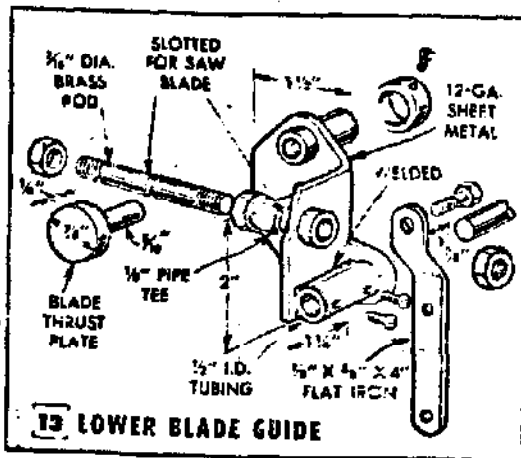

which make up the complete guide. The short length of tubing which forms a bearing for the blade thrust plate fits into a collar welded to the top of the pad. The latter is welded to a short support rod which passes through a hole drilled transversely at the lower end of the sliding guide rod, Fig. 2, and also Figs. 7 and 8. When the assembly is made, a second rod, 3/8 in. in diameter, is attached to the sliding guide rod with a bracket arm at the upper end. The smaller rod is passed through a hole drilled in the upper arm and the lower end is then bent at a right angle and inserted in a hole drilled part way through the sliding rod, Figs. 8 and 14. This rod, sliding parallel with the support rod, serves to hold the blade guide in the same position relative to the saw blade when the guide is raised or lowered.

The two angles, Fig. 9, are bent to shape from 24-ga. sheet steel and are drilled and

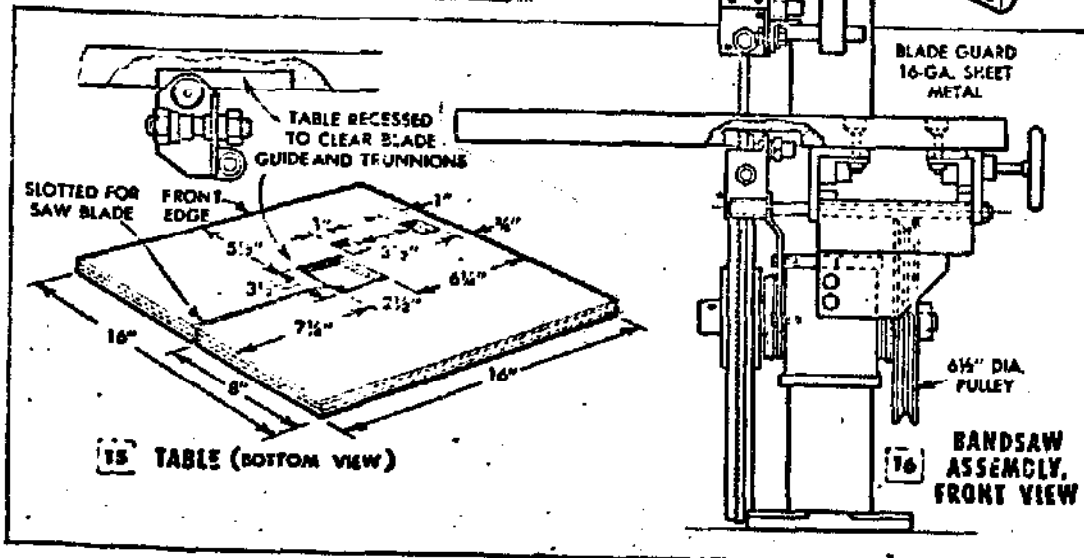
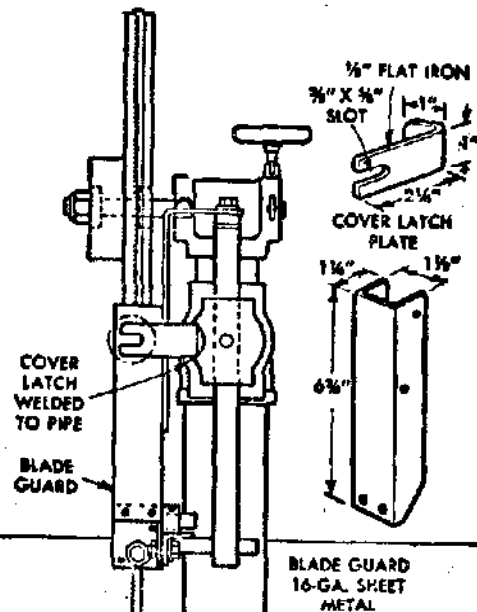

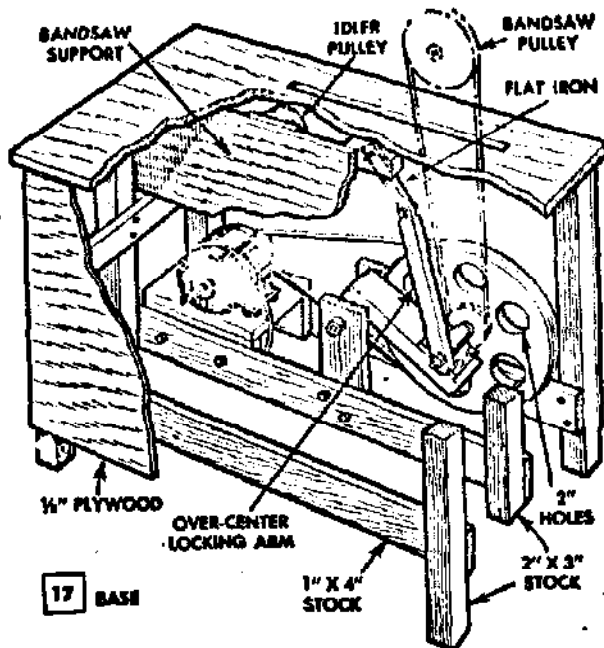

tapped as indicated. The brass guide pin is threaded at each end and slotted at the center for the saw blade. The guide pin is an easy, sliding fit in the reamed pipe tee and a nut on each end permits a lateral adjustment to position the blade in the center of the wide slot in the tee. The thrust plate and the assembled guide pin are shown in position in Fig. 8. Fig. 9 shows a $\frac{3}{16}$ -in. dowel pin, or plug, in the left-hand slot of the mounting pad. The projecting end of the pin enters a hole drilled and reamed through the left-hand angle bracket of the guide and serves to hold the parts in alignment. However, if desired, the hole can be tapped and a cap screw used as in Fig. 8.

The lower blade guide, Fig. 13, is quite similar to the upper guide except that it is supported by a horizontal rod and a flat-iron bracket, which is bolted to the angle bracket and to the side of the lower pipe tee. The horizontal rod enters a hole drilled in the outer half of the trunnion which is next to the guide. The opposite end is inserted in a bushing welded to the side of the angle bracket. Parts of this guide can be made at the present stage of the construction, but do not attach it to the frame until the table has been made and fitted in place and the wheels completed and mounted on the spindles. Then, with a blade in place on the band wheels, it is an easy matter to locate the lower guide in the correct position.

After making the frame guides and table trunnions, the two-speed bandsaw is completed by making the band wheels, table, guard and floor stand which houses the drive. The finished job is shown in Fig. 20. The band wheels are made of $\frac{1}{4}$ -in. hardboard, three disks and one ring of this material being laminated to give a 1-in. tread width, Fig. 10. The hub of the upper wheel is built out with four additional disks of hardboard to provide a bearing mounting as in the sectional

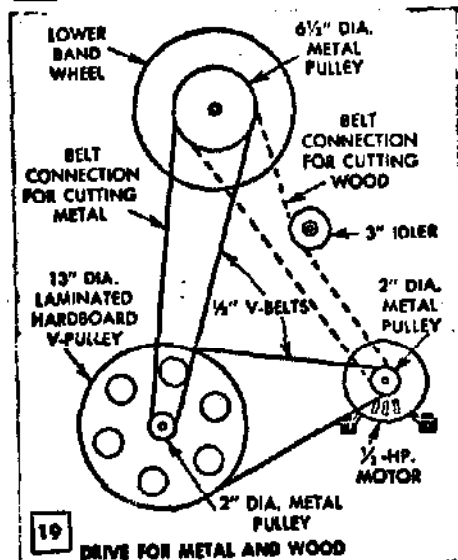
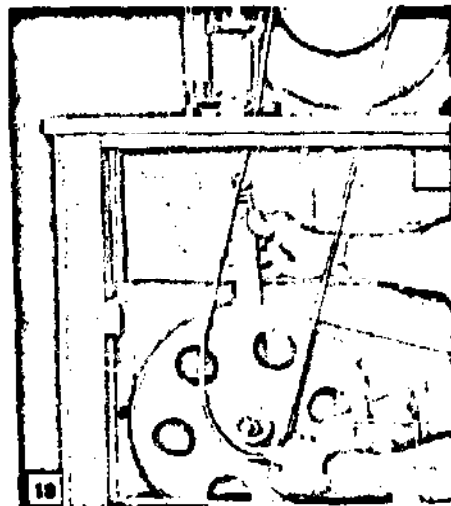

view, Fig. 10, while the lower wheel hub is made from two $\frac{1}{2}$ -in. pipe flanges as indicated. Before mounting, the wheel treads are trued in a lathe and fitted with 1-in. rubber tires. The hub of one lower-wheel flange is drilled and tapped for a set-screw which is tightened onto a flat filed on the shaft. The table, Fig. 15, is made from $\frac{3}{4}$ -in. birch plywood and is recessed on the bottom side to fit over the trunnions and blade guide. It also is slotted from one edge to the center to permit insertion and removal of the blade. Fit the table to the trunnions before cutting the slot so that the location of the latter can be determined. The $\frac{1}{4}$ -in. plywood wheel guard, or cover, detailed in Fig. 10 is not essential, although you can include it if desired. However, the blade guard, Figs. 10 and 16, is a necessary

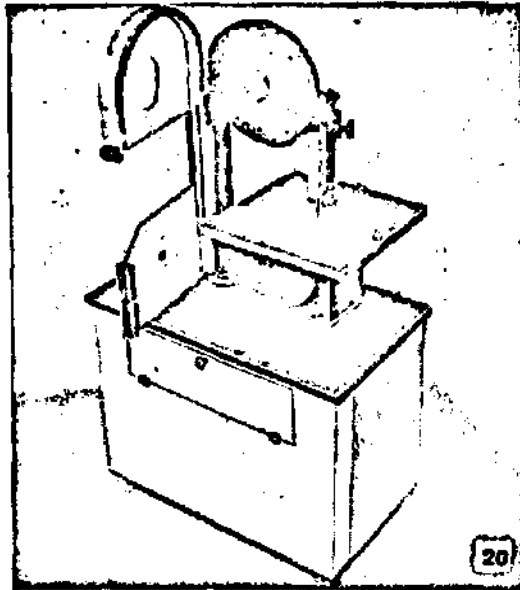

safety feature and should not be omitted. Figs. 11, 12, 18 and 19 show how the drive is assembled for cutting wood and metal. Fig. 17 details the closed stand and pivoted jackshaft. Of course, an open stand, 30 in. high, will serve equally well. The jackshaft is raised for changing belts by a special lever, pivoted at the ends and center as in Fig. 18. The lower end is provided with a bushing to fit the jackshaft. Two pillow-block bearings placed side by side can be used as a jackshaft bearing in place of the single bearing. A 12-in. metal V-pulley may be substituted for the 13-in. laminated pulley. Before operating the machine be sure the blade is centered on the band wheels and is bearing lightly against the blade guides.

Stub Boring Bar Fits Lathe Spindle

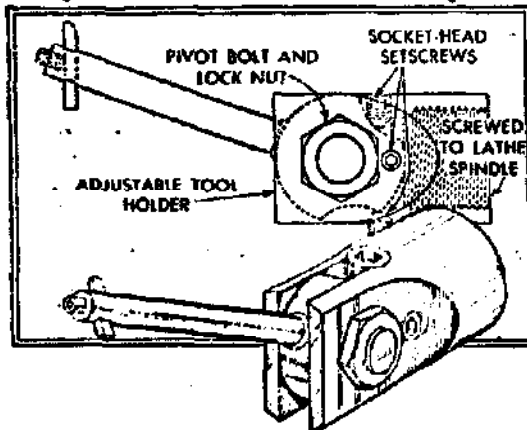

Designed for boring and facing operations on work which is too large to swing between centers, this unusual boring tool

is screwed onto the threaded lathe spindle and operated eccentrically, in a manner similar to a fly cutter. The tool-bit holder pivots and is adjusted for swing by means of two socket-head setscrews, while a third setscrew serves to hold the bar in position until the locknut on the pivot bolt is tightened securely. The locking setscrew should be a wringing fit to overcome the tendency to loosen by vibration. With the work remaining stationary and the tool rotating, the size and shape of the work determine the manner of mounting it, whether it be on an angle plate or the saddle of the compound rest.

Marker for Lathe Threading Chart

Accurate reading of a lathe threading chart is simplified by use of a sheet-metal marker. When setting up the lathe the marker is moved to the proper position on

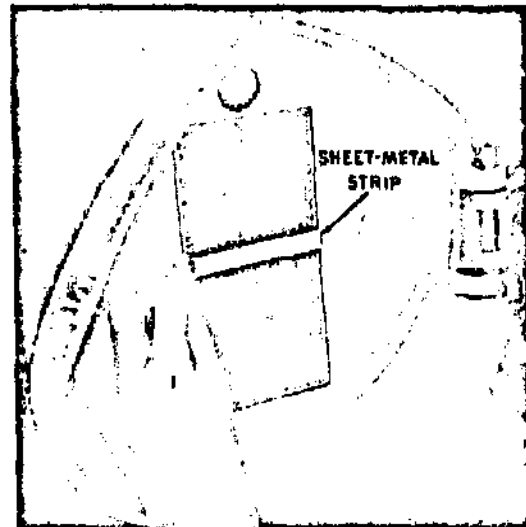

the chart, and, if left in place, the threads or carriage feed to which the lathe is set can be noted at a glance. The guide is formed by bending the ends of a 1/2-in.-wide strip of sheet metal so that they clip under the edges of the threading chart. There should be a slight clearance between the strip and chart face so the only contact is at the edges and back of the chart.

Formula for Machine-Screw Sizes

When you want to duplicate a particular machine screw on your lathe, it isn't necessary to search through a handbook to find the diameter to which the blank must be turned. Just remember to multiply the number of the screw by .013 and add .060. Thus, the diameter of a No. 2 screw is $2 \times .013$ plus .060, or .086 in. A No. 3 screw is $3 \times .013$ plus .060 or .099 in.

x802B

AT MICROFICHE
REFERENCE
LIBRARY

A project of Volunteers in Asia

Wood Planer for \$100 Popular Mechanics No. 802B

by: Ronald Guy

Published by:
Popular Mechanics
224 West 57th Street
New York, NY 10019 USA

Paper copies are \$ 2.25.

Available from:
Popular Mechanics Plans, Dept 77
Box 1004, Radio City
New York, NY 10019 USA

Reproduced from Popular Mechanics. (c) The Hearst Corporation. All Rights Reserved.

Reproduction of this microfiche document in any form is subject to the same restrictions as those of the original document.

Aug 70 174

302 B

WORKSHOP PROJECT

Build This Wood Planer For \$100

This shop-built version of a great power tool stacks up impressively when compared to those offered commercially for \$300 and up

By RONALD GUY

AS your wood-working experience grows, you suddenly realize there is virtually no "bad" lumber. You finally reach the point where every piece of scrap, or low-grade lumber, is hoarded along with dressed stock for future projects. To make use of that lumber, though, a trip to the lumberyard is usually necessary to have its mill do the dressing. Tiring of those trips (too much time waiting to be served) is what sold me on the idea of constructing my own thickness planer.

I built the one shown in my spare time over a one-month period. (This does not include the many hours I spent designing the rig and drawing the plans.) My total cost to build was \$96.34, roughly one-third the cost of comparable commercial versions. To keep the cost that low, I spent considerable time shopping around for parts and comparing prices.

The major tools that you will need are a metal lathe, drill press and an arc welder. Nice to have, but not absolutely necessary, are a power

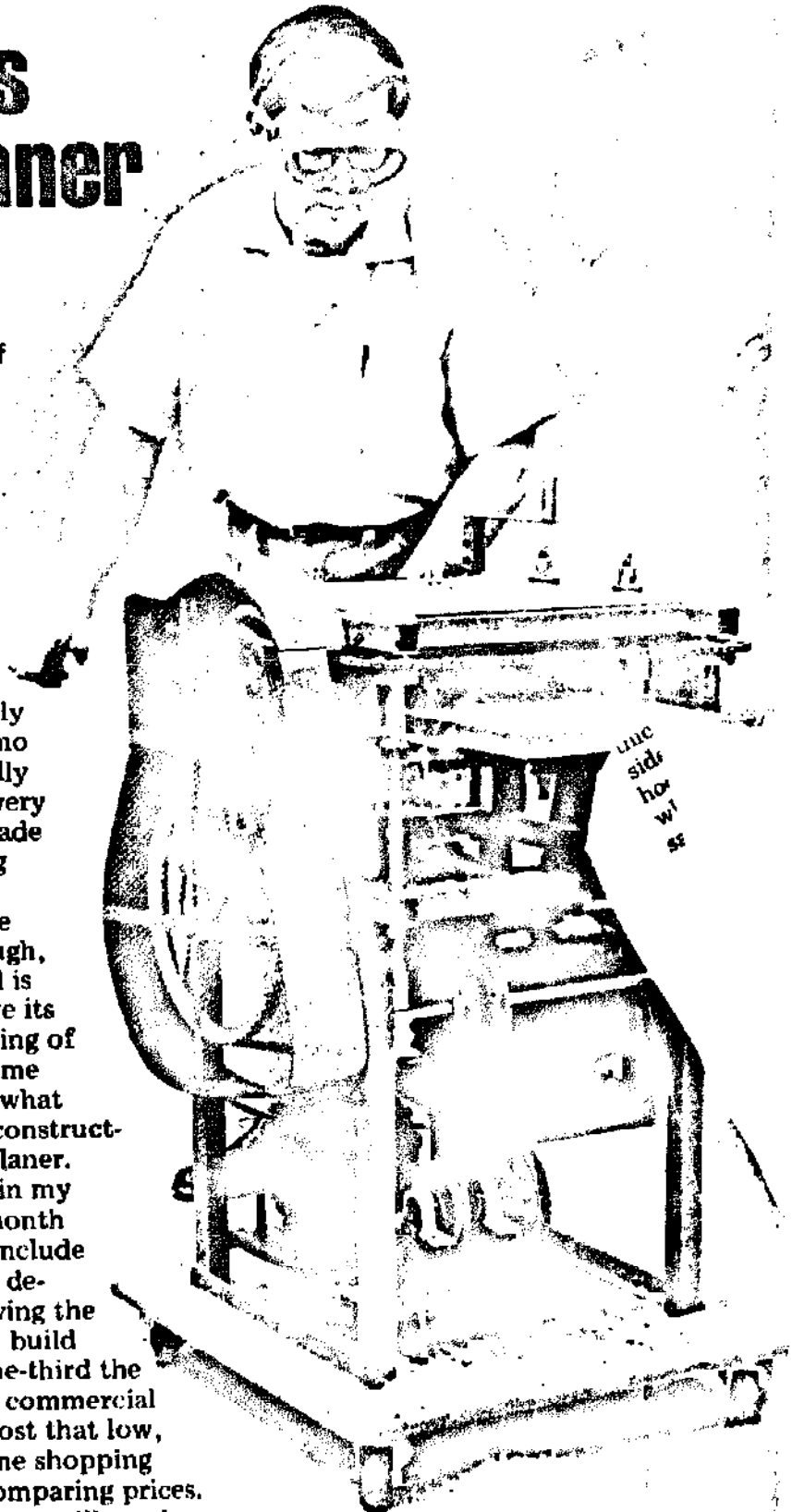

the
side
how
will
se

Photos by the Author
and Rose Marie Guy

hacksaw, portable drill and a die grinder for grinding weld beads. Lacking these tools, you could do the major portion of cutting and then cart the bundle of parts to a machine shop for assembly. If you decide on this approach, I recommend taking the drawings to the shop first for an estimate. Then, if cost is within your budget, you can start shopping for parts.

After testing various styles of cutter-heads, I decided to make a simple two-knife design of flat 1 x 2½-in. steel. Despite its simplicity, it compares favorably with more elaborate types. To keep cost down, all chains and sprockets are common bicycle-stock items. The main frame is 1¼ x 1¼-in. heavy-wall steel tubing, with a little angle iron here and there as needed. The planer bed is a sheet of ½-in. steel plate but some other material, even

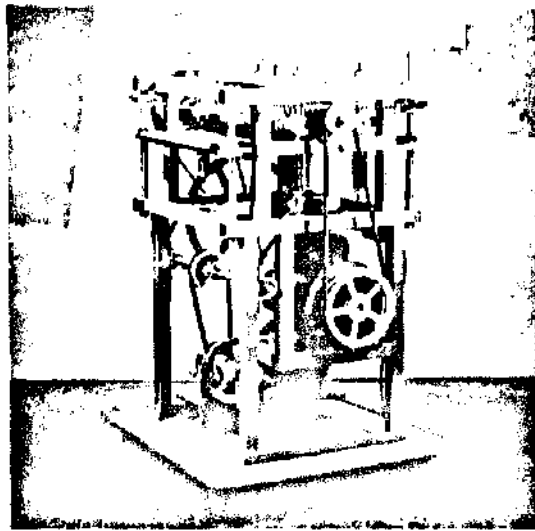

FINISHED PLANER (minus guards) is shown from out-feed side. Castor-mounted tool can be moved easily

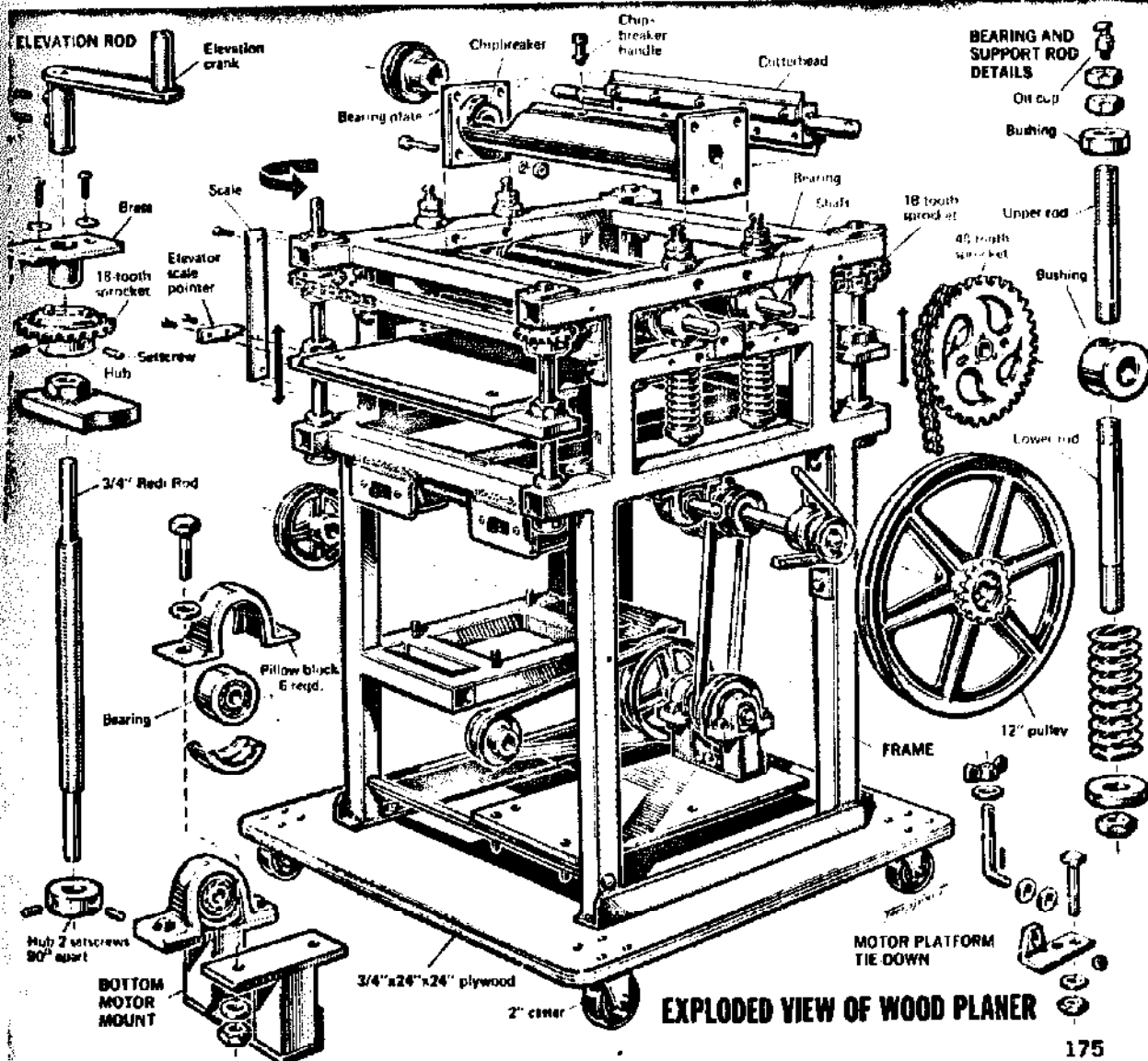

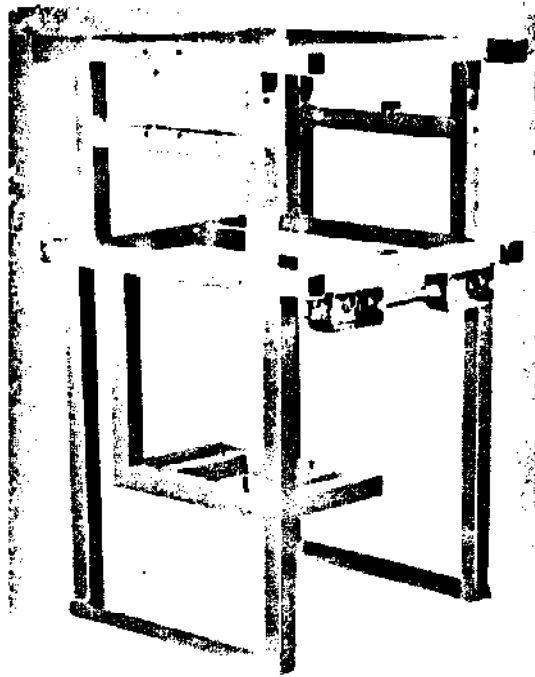

FRAME IS ASSEMBLED and all holes are drilled for mounting bearing plates, pillow blocks and guards

wood, could be substituted if necessary. Table elevation screws are $\frac{3}{4}$ -in. Redi-Rod available at hardware stores. Feed

rollers are of $\frac{3}{4}$ -in. cold-rolled shafting, $1\frac{1}{2}$ -in. water pipe, wood and radiator hose.

I suggest purchasing all materials before you begin construction; that way if you can't find exactly what's needed, or desire to substitute, you can make allowances in dimensions.

● *Making the frame.* Cut all members slightly overlong, then grind or file ends square and bring each piece to exact length. Next, lay out and drill all holes; accuracy is critical. At this point, you can tap those holes that require threads. Now make a jig, using a double thickness of $\frac{3}{4}$ -in. plywood to hold all base parts in correct alignment while they are welded. Clamp all parts in place, weld the first side and grind down the beads. Flip the frame on the jig and repeat the welding procedure. Remove from the jig and finish by welding the inside joints. I used a $3/32$ -in. rod (mild steel, general purpose) at 75 amps. for outside joints, increased to 85 amps. for inside ones.

After making the second side, take both sides and set them upside down on a firm, level surface. Working carefully, set the spacer bars between the two side frames,

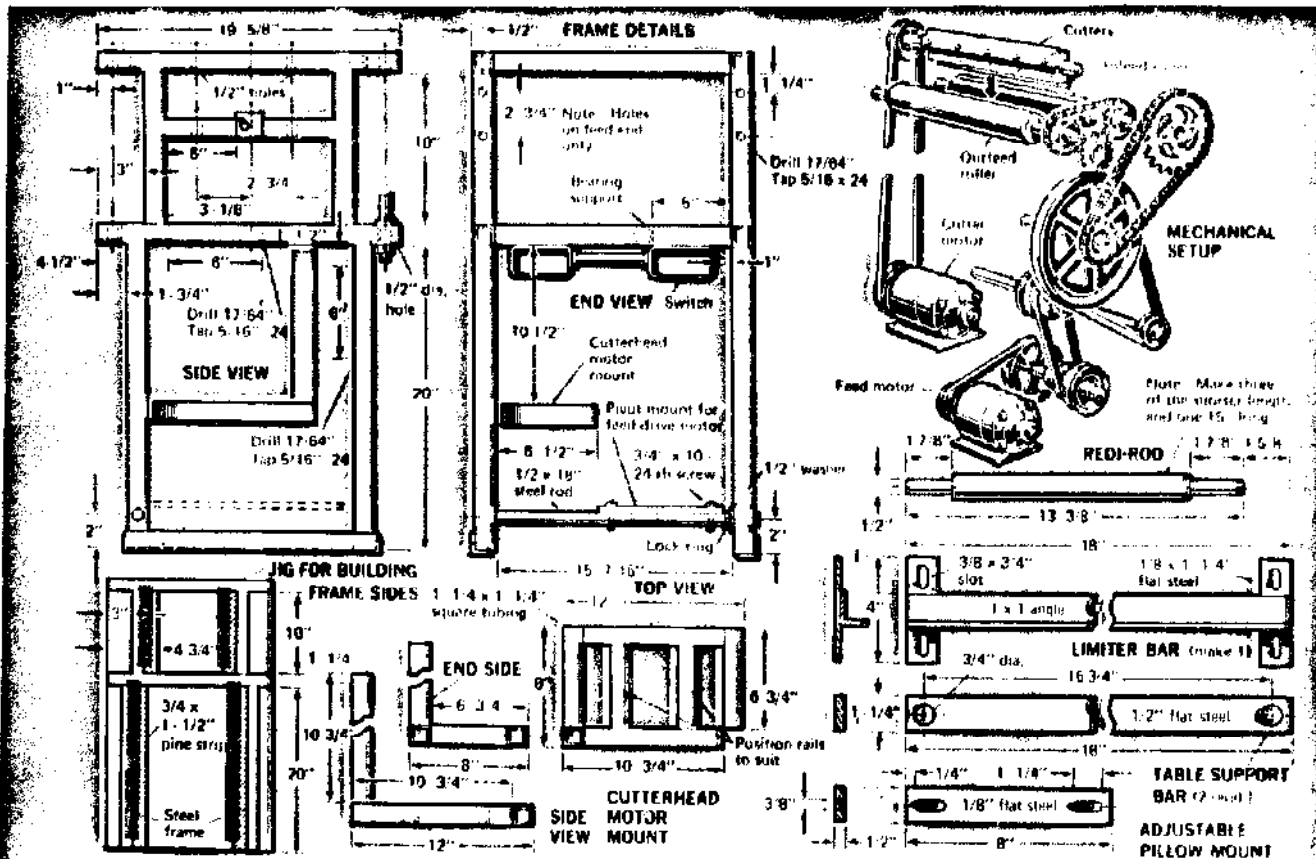

square the setup and clamp securely. Now the entire assembly can be welded together. Check frequently as you go to insure that welding heat doesn't pull things out of square. Now is the time to put in all braces, spacers and the like that are called for. It's also good to mount the support for the cutterhead motor and get everything out of the way that will require welding to the frame at this point.

If you're careful, you will find that all holes will line up as planned. But if they don't, there's a certain amount of tolerance designed into this project and I'll tell you later what to do. Finish the frame by mounting it on a 3/4-in. plywood baseboard, as shown on page 175.

● **Cutterhead bearings.** Cut the support plates from 1/4-in. steel and drill a No. 7 hole at each corner as shown. Turn the bearing support shells from heavy-wall steel pipe; also turn the finished area on the outer diameter of the bearing shell for mounting the chip breaker support later. Position the shell carefully on the support plate and weld securely. Mark one plate left, another right. Also indicate which is the top side of each. Find the center on the top side of each and scribe a mark. Locate

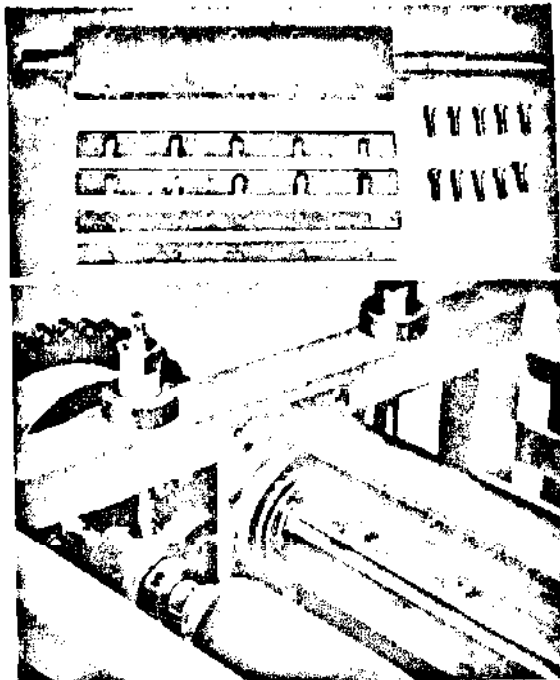

CHIP BREAKER is mounted on bearing plate; extra holes were not used. The cutters are shown above

the scribe center line on the frame of the planer, place each bearing plate in correct position and clamp securely. Make

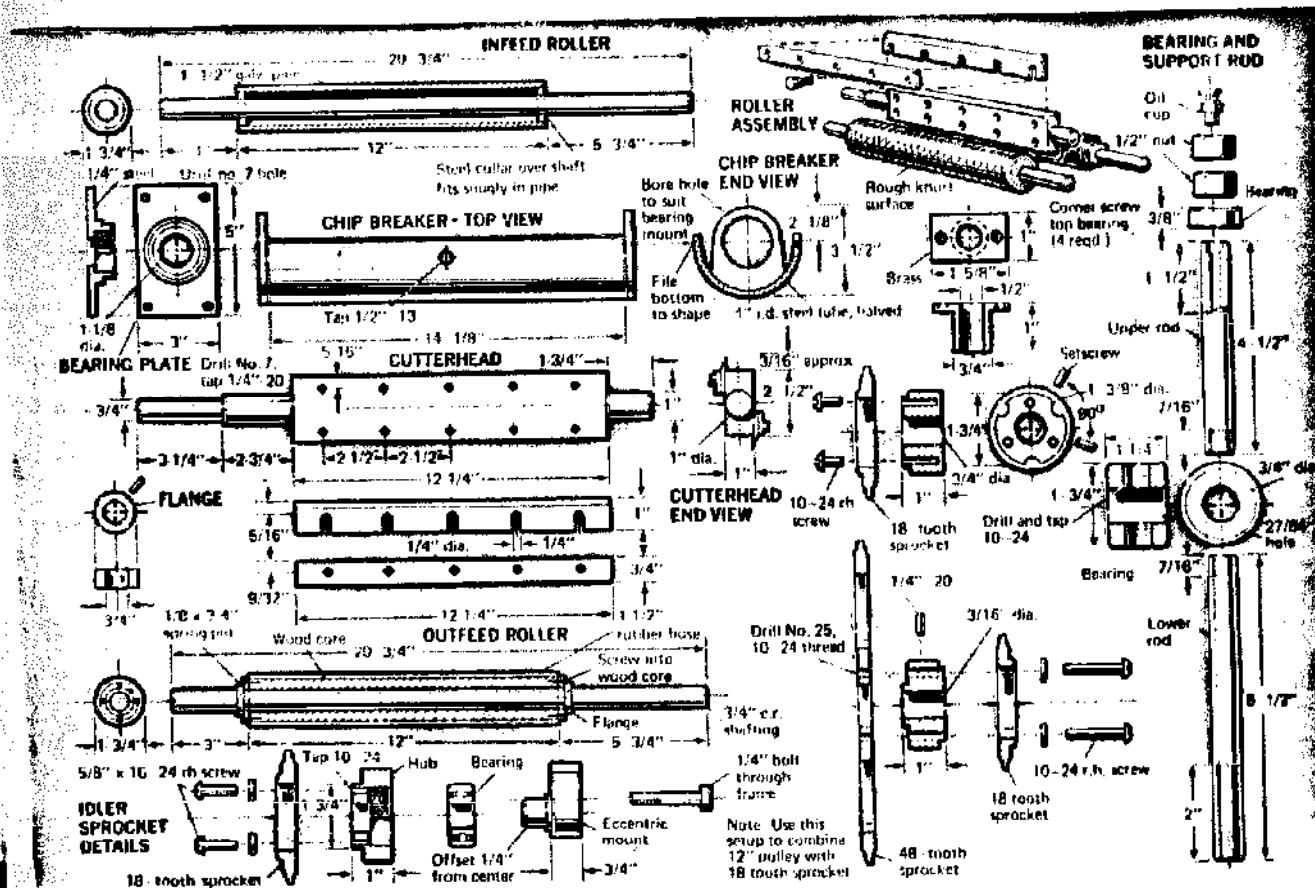

sure each is absolutely centered, then take a No. 7 drill, and, using a hole in the plate as guide, drill all the way through the frame. Do this for both plates at all four corners, then remove the plates, enlarge holes in the frame to $\frac{1}{4}$ in. and tap the No. 7 holes in the plates $\frac{1}{4}$ in.-20.

● **Cutterhead.** Make sure that the steel bar is straight and true. Lay out centers carefully so the head will run true and not vibrate. Also, lay out holes for blade mounting bolts and thread $\frac{1}{4}$ in.-20. Slot the blades and make up the back-up strips.

● **Chip breaker.** Cut a piece of 4-in. i.d. heavy-wall steel tube lengthwise (slit it) and you'll wind up with an ideal curved piece to which you need only add $\frac{1}{4}$ -in. steel-plate supports made to fit over the exterior of the cutterhead bearing shells. File or grind the bottom to shape so stock being planed will tend to "push up" the chip breaker. You'll probably have to experiment with this. Make a jig to hold everything in alignment when welding on supports, or temporarily set the bearing plates in the frame and use those as your jig. Everything has to align well or it will bind.

● **Assembly.** Mount the bearing plate on the right side (feed drive assembly) of the machine; place cutterhead in the chip breaker, push long end of shaft as far as possible into the bearing plate. Hook

chip breaker support over bearing shell support and push it on, while continuing to push the shaft into the bearing. Now take the other bearing plate, turn it sideways so it will go through the frame, push it on the cutterhead shaft and hook the free end of the chip breaker support on the bearing shell. Continue pushing as far as possible, then rotate the bearing plate into correct position and fasten it permanently. Center cutterhead and lock the bearing setscrews. Be sure the chip breaker moves freely.

● **Feed rollers.** Clean the inside of the rubber tube thoroughly and rough it with a file before applying contact cement. Brush the cement on the wood core (already on the shaft), pour the cement into the hose, then immediately pour it out; let both dry thoroughly, then refill the hose, pour it out again and immediately slide the hose over the core. Let it dry 24 hours. If it's not correctly constructed and roller height is improperly adjusted, you will have trouble with the outfeed roller. The infeed roller, being all steel, is easier.

● **Feed roller bearings.** Turn and bore as shown, using brass, aluminum or steel. Then drill a $\frac{27}{64}$ -in. hole all the way through both sides. Tap $\frac{1}{2}$ in.-13 (again through both sides at once). This is a must to insure that support rods are being true in relation to the bearing.

● **Support rods.** Use cold-rolled $\frac{1}{2}$ -in.

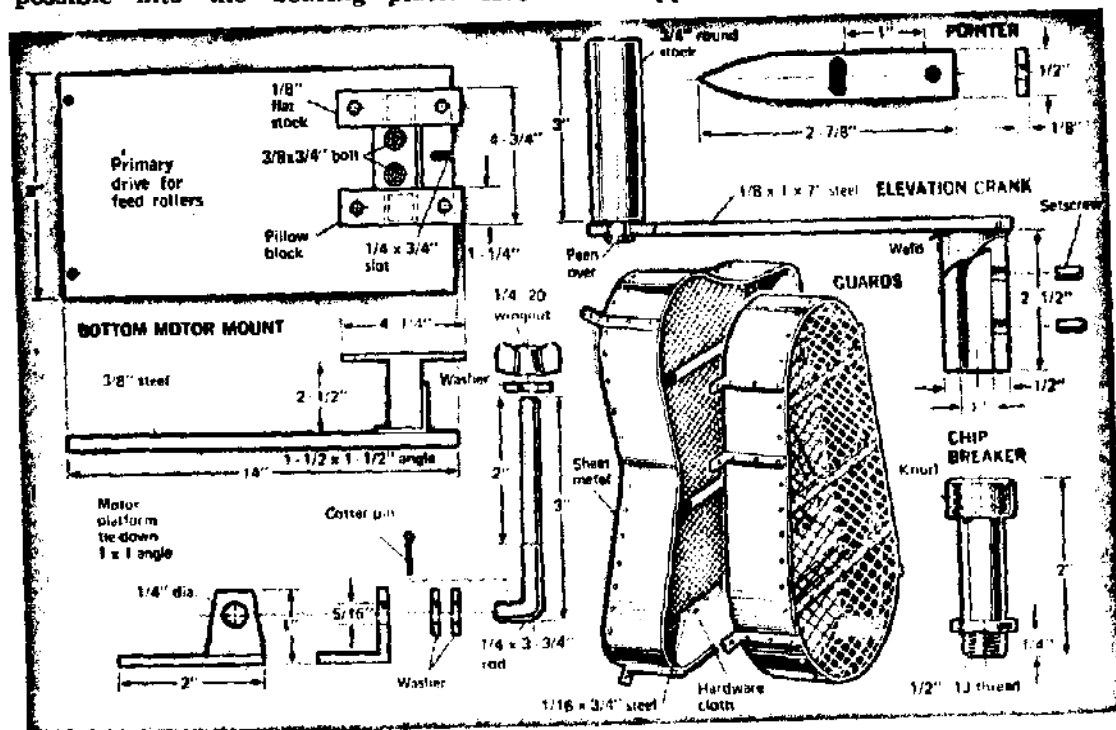



DEPTH-OF-CUT SCALE is shown at left; note oil cup on top of rod. Center photo shows the three-step pulley arrangement plus the hold-down that keeps belt tight between step pulleys. At right, the small sprocket behind a larger one is the idler sprocket described in text. Pulleys are of 2 and 12-in. diameter

steel for these. Cut to length and thread them $\frac{1}{2}$ in.-13 in the lathe! This must be done so they'll be straight in the bearings. Notice that the upper support rods are drilled all the way through $\frac{1}{8}$ in. and then counterdrilled $\frac{1}{4}$ in. for a short way at the top to accommodate oil cups. I had to drill mine from both ends to get the $\frac{1}{8}$ -in. hole all the way through. It's necessary though, so the bearings can be oiled when the guards are on the machine.

● **Assembly.** Install the lower rods through holes in frame, install springs and washers and put the nuts on the bottom but do not tighten yet. On the right side (feed-drive assembly) of the machine place the bearings on rods, then install the upper rods and tighten all securely in bearings. Install shaft collars and fiber thrust washers on feed rollers and push the long end of the shaft into the bearings just installed. Next, install bearings on left side of machine, tightening rods securely into the bearings. Center rollers in the frame and lock the shaft collars to hold them.

Since the support rods are designed to slide up and down in the holes in the frame, you should be able to move the entire roller assembly up and down. If you have a problem, take out the upper rods and enlarge the holes enough to give these rods a little clearance. (I mentioned

(Please turn to page 194)

MATERIALS LIST

Amt.	Size and Description (Use)
32'	$1\frac{1}{4} \times 1\frac{1}{4}$ " heavy-wall steel tubing (frame)
3' ea.	$\frac{3}{4} \times \frac{3}{4}$ " 1×1 " & $1\frac{1}{2} \times 1\frac{1}{2}$ " angle iron (frame)
3'	$\frac{1}{8} \times 1\frac{1}{4}$ " flat iron or steel
2'	$\frac{1}{8}$ " x 1" flat iron or steel
1 pc.	$\frac{1}{2} \times 13\frac{1}{2} \times 20$ " steel (planer bed)
18"	$\frac{1}{4} \times 3$ " steel (bearing plates and chip-breaker support arms)
14 $\frac{1}{8}$ "	4" I.D. steel tube or pipe (chip breaker)
4'	$\frac{3}{4}$ " shafting (feed rollers)
4'	$\frac{1}{2}$ or $\frac{5}{8}$ " shafting (feed reduction drive)
8	18-tooth $\frac{1}{2}$ "-pitch bicycle-type sprockets
1	48-tooth $\frac{1}{2}$ "-pitch bicycle-type sprocket
3	Bicycle chains, 3 extra links $\frac{1}{2}$ " pitch
1 pc.	$\frac{3}{4} \times 24 \times 24$ " plywood (baseboard)
4	2 $\frac{1}{2}$ " heavy-duty swivel casters
6	Self-aligning-type ball bearings (pillow block bearings, $\frac{1}{2}$ or $\frac{5}{8}$ " depending on shaft used)
2	Dayton bearings, 2" O.D. with 1" bore and 2 setscrews (cutterhead bearings)
Note: Cutterhead shaft must be sliding fit through bearing race which must be locked to the shaft	
1 ea.	1 $\frac{1}{2}$ " 6" pulleys
2	3-step pulleys
1 ea.	2", 12" pulleys (feed roller drive)
1 ea.	3", 7" pulleys (cutterhead)
Note: All pulleys are for 1725-rpm motor	
1	$\frac{1}{4}$ -hp motor (feed roller drive)
1	$\frac{1}{2}$ -hp motor (cutterhead)
2	12" high-speed steel knives (heavy as possible)
	aluminum, brass or steel stock
18"	2" dia. stock (hubs, roller bearings)
2 pcs.	$\frac{3}{4} \times 36$ " threaded rod
4	$\frac{3}{4}$ " nuts
2	$\frac{1}{2} \times 1\frac{1}{4} \times 18$ " steel (table supports)
1	$1 \times 2\frac{1}{2} \times 20$ " steel (cutterhead)
2	$\frac{1}{8} \times \frac{3}{4} \times 12$ " steel (cutterhead backup strips)
1 ea.	28, 29, 43" belts (for feed drive)
(Note: Belt size for cutterhead drive is determined by motor used)	

Miscellaneous—four $\frac{1}{2}$ " shaft collars, two $\frac{3}{4}$ " shaft collars, 24 $\frac{1}{4}$ "-20 x $\frac{1}{2}$ " setscrews, assorted nuts and bolts, steel strap material for guards, electrical wiring, switches, paint and rivets, four 3" heavy springs, 48" of $\frac{1}{2}$ " c.r. shafting for roller-bearing supports, four fiber washers $\frac{3}{4}$ " hole, four $\frac{1}{4}$ " oil cups (remove wicks if any), 12 $\frac{1}{2}$ x 13 nuts, one $1\frac{1}{2} \times 12$ " pipe for infeed roller, one $1\frac{1}{2} \times 12$ " rubber radiator hose for outfeed roller

WOOD PLANER FOR \$100

(Continued from page 179)

earlier that a certain tolerance was built into the machine.)

To construct and assemble the table and elevating mechanism, place the table supports on lower section of the frame. Drop corner screws through 3-in. holes, slip through the hubs of sprockets, turn through the nuts in table supports and put on a washer. Continue turning until a 1/2-in. section of the screw is as far through the frame as it will go and put on the shaft collar beneath. Do all corners, then check to make certain all four ends of table supports are the same distance from frame. Now bring sprockets nearly to the top of the screw (until they just miss the upper frame member) and lock to corner screw securely with two setscrews.

Next, install the chain, and finally, put the upper bearings in place and tighten down with screws. Install the crank and check to see if the table supports move up

... this machine has feed speeds of approximately 6, 12 and 24 feet per minute

and down smoothly. If not, take off shaft collars on bottom of screws and lift shafts out of the way. Enlarge holes slightly and reinstall screws and collars. Now try again and, if okay, bolt on the table. Check to insure that there is no twist in the table. If there is, shim one or more corners.

Next, install the blades, adjust the feed rollers and finish the slight amount of work still left on the chipbreaker. These steps done, there are left only the fabrication and installation of the feed-roller drive and the guards.

● **Blades.** Take two hardwood blocks about 1x1x2 in. and place them on the table on each side of the cutterhead. Bring the table up so blocks are about 1/4 in. from the head. Now, loosely bolt the blades to the head and rotate the head so a blade is pointing straight down; adjust the table up until a blade projects about 3/16 in. from the head. Lightly press down the back of a screwdriver blade on one end and tighten the bolt on that end. Repeat on the other end. Now check that the blade rests equally on a block on each end, then install the second blade. It is important that both blades project equally.

● **Outfeed roller.** Adjust the table so the blades just tip a block of wood as the head is rotated; then, using that same block (but without moving table hereaf-

ter during adjustments), adjust the outfeed (rubber) roller as follows: Tighten the nut on top of the top support rods to raise the roller just enough so that you can slide a wood block under either end. Go underneath and put considerable tension on the springs on the lower rod. Slightly lower the roller by easing back a little on the upper nuts until you can put the block under the roller, turning the roller backward by hand. Drop the roller just enough so that it is hard to keep it from forcing the block out when the roller is turned in an opposite direction. The outfeed roller should never have to travel more than 1/2 in. vertically when a piece is coming under it (3/8 in. is even better). Power to move the piece out is supposed to be provided by pressure of the springs. The rubber hose will be torn loose from the wooden core if the rubber is distorted too much. You can prevent this only by correct adjustment.

● **Infeed roller.** It is adjusted similar to the outfeed, but you won't need quite as much pressure on the springs. Because of varying stock thickness coming into the machine this roller will have as much as 1/4-in. vertical travel.

● **Chipbreaker adjustment.** With the table adjustment as it has been for roller adjustment, take the same block of wood previously used and set it on the table to support the chipbreaker in that position. Now bore a No. 7 hole into the side of the chipbreaker so that a 1/4-in. bolt installed in it will rest on the side of the bearing plate. Thread the hole 1/4 in.-20 and install a short bolt. This will keep the chipbreaker from dropping down too far when stock is first being fed into the machine. Remember the chipbreaker has to be set so it will be pushed up when stock starts through; then it rides atop the stock during the planing process.

Construct the feed drive as per the plans, giving special note to the mounts for the pillow blocks. These are designed to give considerable extra adjustment. As designed, this machine has feed speeds of approximately 6, 12 and 24 feet per minute. This is achieved by using a pair of three-step V-pulleys used early in the reduction drive. The feed drive motor and first stage of reduction, with one three-step pulley, are mounted on a metal platform bolted to a 1/2-in. rod. This serves as a pivot on one end to facilitate keeping the belt tight. From this, the second step pulley is driven. A 2-in. pulley, mounted on the same shaft, drives a 12-in. pulley on another countershaft. The latter pulley is mounted on a common hub with an 18-tooth sprocket connected by chain to a

(Please turn to page 196)

Start your own MONEY-MAKING BUSINESS

Every home and building offers you potential income. Clean wall-to-wall carpeting, upholstery and walls on customers' premises with Von Schrader professional cleaning equipment. Work part time or full time. No fees, no contracts to sign. You own your equipment. Proven reliable and profitable for thousands of users. Enjoy a steady, growing business with Von Schrader Detergers—and we'll help you every step of the way. Write today for full information.

VON SCHRADER MFG. CO., 1081 Place, Racine, Wis., 53403

Send for
FREE Booklet

Name _____
Address _____
City _____ State _____ Zip _____

RECHARGE ALL BATTERIES

Only Everlite

- Charges 6 batteries
- Charges 3 times faster
- Charges all batteries

Including hearing aid, flashlight, lantern, radio. In fact any battery up to 12V. Save Money and have the convenience of fresh batteries always. Simple and 100% safe. Plugs into any 115V. outlet. Guar. for one year. Send \$6.95 plus \$1.65 for shipping.

695

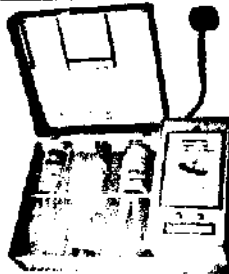

Model 75

MASTER MECHANIC MFG. CO., Dept. ADD, Burlington, Wis.
Southern Customers write Dept. ADD, Box 65, Sarasota, Florida

Join the
"New Jet Set"
and see the
world for FREE . . .



as a member of the booming AIRLINE & TRAVEL INDUSTRY!
Imagine flying to exciting places like Acapulco or the Riviera FREE . . . or at a fraction of what the regular public pays!

Right now there are thousands of great career positions just waiting to be filled in the booming Airline & Travel Industry. This is one field where you can do more, see more, live more in a year than most people in a lifetime! Best of all, you could qualify in a matter of months with expert training from Career Academy! You can study right at home, in your spare time—or attend a nearby resident training center.

FREE BOOKLET OFFER! Mail coupon below for colorful Booklet with full information.

CAREER ACADEMY 07N019204
Airline and Travel Division
825 N. Jefferson St., Milwaukee, Wis. 53201
Please rush FREE booklet on airline and travel careers.

Print Name _____
Address _____
City _____ State _____ Zip _____
County _____ Age _____ Phone _____
I am interested in: Resident School Home Study

WOOD PLANER FOR \$100

(Continued from page 194)

48-tooth sprocket mounted on the outfeed roller shaft. The two feed rollers are then connected by chain running on 18-tooth sprockets mounted on the shaft of each. Thus, when the outfeed roller turns, so does the infeed. For simplicity I used belts and pulleys as far as I could. In the final drive stages, I had to go to chains and sprockets to avoid slippage and insure synchronization.

Assuming all prior adjustments are correct, you are now ready to hook up the feed drive. Connect the large 48-tooth sprocket to the 18-tooth one on the same hub with the large pulley. The chain should be snug but not tight. When the stock passes under the outfeed roller it pushes the roller up slightly and the chain must give a little. Next, hook up the chain between the two rollers, adjusting the idler so that, when the machine is idling the chain is fairly tight. Stock passing under the rollers, especially the infeed roller, removes a lot of pressure from the chain so it must run without any slack when idling. Now you must adjust the belt tension from the 12-in. pulley to the 2-in. one. This must also run rather tight to avoid slippage, because you have a high torque load with low speed. The next belt tension to adjust is between the step pulleys—this is simple because of the pivoting platform mount. At this stage you should have adjusted the belt tension between the drive motor and the first countershaft. This need be no tighter than normal for a belt.

Expect to spend some time getting all adjustments just right so the machine runs smoothly and feeds correctly. I found this the most exasperating part of the job but, once fixed properly, the machine rarely needs adjustment.

● *Finishing touches.* With the feed drive system installed, you are ready to hook up the cutterhead drive and test the planer. Start off with light cuts and slow feeds. As you become familiar with the machine you'll be able to get the maximum from it. Install the depth-of-cut indicator as soon as you get the basic outfit operating right. The final items are the guards, which I strongly urge you to build. They can be made in an evening. For safety, construct the top cover for the planer; it can be of 1/4-in. hardboard. These parts keep hands away from moving parts.

● *Some observations and hints.* Never stand in line with the cutterhead of a planer. If it should throw a knife, you don't want to be the "catcher." Remember that a machine with a welded frame doesn't have the rigidity of a heavy-duty,

cast-iron type. Thus it won't take as heavy cuts and as much abuse. I powered the cutterhead on mine with a 1½-hp motor and am happy with it.

It is good practice from time to time to check and, if necessary, retighten the bolts holding the cutter blades. Though I haven't had one come off yet, an occasional bolt has worked loose.

When you want to change blades remember to lay a piece of wood on the table, and raise the table until the blade is resting on the wood, just as it did when you first installed the blades. You can then reinstall the sharpened blades in exactly the same position as they were when you removed them. Otherwise, you may have to readjust the feed rollers. ★★★

NEW SUPERTRACK

(Continued from page 113)

quarters of a million range, or nipping on the heels of the Indy classic. (The purse at Indy this year topped a million for the first time: \$1,000,002.02, to be exact.)

Second major event, Nov. 21-22, will be the all-new drag racing Supernationals. It promises to be the biggest event in National Hot Rod Assn. (NHRA) history with purse pushing \$250,000.

NASCAR, the National Assn. for Stock Car Racing, is next on the grid with a 500-mile Grand National event Feb. 28, 1971—two weeks after the Daytona 500.

Scratched this past spring by the international sanctioning body were plans by the Sports Car Club of America (SCCA) and OMS to run another U.S. Grand Prix in May, in addition to the U.S. Grand Prix in Watkins Glen, N.Y., in October. It appears that GPs will continue to be doled out one to a country and that some other super SCCA race for the road course will be conceived (maybe F1 cars running for money but no championship points).

In any event, the spring of '71 will bring a big road race—whether it's F1, Can-Am or Trans-Am remains to be seen.

Unlike the Indianapolis Motor Speedway, where only one race is run each year (but what a race it is!), OMS will be dealing in on all the wheeling it can. The climate allows year-round operation and that's the goal. The track has been open for several months for tourist ride-arounds, and will have other attractions—like a hall of fame and technical tours.

Extensive use of OMS for testing and promotion is another goal of the organizers. This would include the usual tire and car testing programs as well as safe-driving contests, driving schools, other activities

(Please turn to page 198)

GOVT. SURPLUS AND OTHER BARGAINS SAVE UP TO 90%



DC FAN Set in its own R7A x R7A housing with 3 adjustable deflectors. A choicable door to prevent draft when not in use. Mount in boat, bus trailer, machine room to circulate air in or out. Runs on 12 or 24 Volt. Price down to \$1.50 (12V). Approx. GOVT. cost \$125. Tested prior to shipment. Ship. wt. 11 lbs. \$12.50 (stk. #2045)

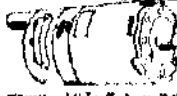

D. C. JET GENERATOR Mfg. by O.K. Rated 400 watts, 2700 RPM. Continuous duty to 24 Volts. Runs up to 600 amps. International duty. For use as welder. Can use as is with no internal rewinding. Complete with wiring diagram. 14 1/2" x 7 1/2" dia. Total overalls 18" dia. GOVT. COST \$401. Ship. wt. 18 lbs. \$59.50 (stk. #1065)



SCAVENGE PUMP Miniature pump unit. 7 1/2" L. x 2 1/2" W. x 2 1/2" H. Positive displacement, rotary vane-type pump. 27 VDC motor. Continuous duty, explosion-proof. Pumps up to 145 GPH @ 1 PSI. Self-priming. For transfer of gas, diesel fuel, etc. In case of fire, for 5 min. Total overalls 10" dia. condition. Approx. GOVT. COST \$241. Now \$14.95 (stk. #2045)



SILVER ANNIVERSARY EDITION

Send \$2c for shipping catalog with list of bargains in hardware, electrical, marine, automotive items, etc. for day guaranteed, order from us. All prices FOB Outer City, 50% deposit on cash. Fed. tax, incl. 5% sales tax, include shipping. Satisfying world-wide customers since 1945.

AIRBORNE SALES CO. Dept. PM

8501 Stoller Dr., Box 2727, Cedar City, MO 64613



Solves Repair Problems

Durham's fills cracks and holes in plaster, wood and tile. Won't shrink or fall out. Economical, easy to use. Big 4-lb. can only \$1.80 at lumber, paint, and hardware dealers, or shipped direct postpaid in U. S. for \$2.25. Money-back guarantee. Order now. Donald Durham Co., Box 803, Des Moines, Iowa 50304



BE A MAN—GET A MAN'S JOB OPERATING HEAVY EQUIPMENT

HYDRAULIC BACKHOES
CRANES
DRAGLINES
CLAMHELLS
SCRAPERS
BULLDOZERS
GRADERS
TRENCHERS

The Construction Industry is Booming! Earn top money in this fast moving, action-packed field. Keep present job and train at home in spare time followed by practical training on our machines under project conditions at our facilities. Nationwide placement assistance. For FREE information fill out and mail coupon today!

Member American Road Builders' Assn.
VA APPROVED FOR VETERANS AND INSERVICE PERSONNEL UNDER NEW GI BILL

UNIVERSAL HEAVY CONSTRUCTION SCHOOLS, Dept. P M
1901 N.W. 7 STREET, MIAMI, FLORIDA 33125

Please Print

Name.....

Address.....

City..... State..... Zip.....

Age..... Phone.....

x609

AT MICROFICHE
REFERENCE
LIBRARY

A project of Volunteers in Asia

Sheet Metal Former Popular Mechanics No. X609

by: Manly Banister

Published by:
Popular Mechanics
224 West 57th Street
New York, NY 10019 USA

Paper copies are \$ 1.75.

Available from:
Popular Mechanics Plans, Dept 77
Box 1004, Radio City
New York, NY 10019 USA

Reproduced from Popular Mechanics. (c) The Hearst
Corporation. All Rights Reserved.

Reproduction of this microfiche document in any
form is subject to the same restrictions as those
of the original document.

X609

Sheet Metal Former

By Manly Banister



A PERFECT CYLINDER every time, in diameters ranging from copper bracelets to custom-made galvanized tubs—that's what this slip-roll former gives you. It makes a fine school-shop project, although its easy enough to make in your own shop, with minimum machining equipment. The former will handle 20-ga. sheet iron up to the full 12-in. capacity of its rollers, and even heavier gauges in narrower widths, or in copper, aluminum and brass. It's fully adjustable to let you spin out lock-joint, riveted or welded tubing in any diameter from 1½ in. up, and makes fast work of such sheet metal projects as garden lanterns and half-round troughs.

Before starting construction, gather all the materials listed on page 195. The 2024-T4 aluminum alloy plate recommended for the ends has a greater tensile strength than steel, yet machines so well that it can be worked with light equipment. The unit shown here was built on a 6-in. lathe with 18-in. capacity between

centers, and a 15-in. drill press equipped with a rotary-table milling vise.

The first step is to mill one side of each end-plate blank square with an adjacent side (the shorter side will become the bottom; the longer, the front). Blue the face of the metal and lay out the pattern by scratching with a scriber. The pattern on page 192 is for the inner face of the left end; just flop it for the right end.

After rough-cutting the bearing-slide sockets as shown in Steps A and B, next page, center-drill the top roll bearing seat, starting with the smallest practical drill (to assure accurate centering) and working up to ¼ in. Drill another ¼-in. hole anywhere on the centerline in the waste area between the legs and bolt the plates together, back-to-back, through a grip bar, as shown at D—this gives you something to clamp in the milling vise.

Now drill all the ¼- and ⅜-in. holes through both plates. Next, mill out the slide sockets (using a ⅜-in. end mill with 1½-in. flutes) to the 1-in. marks through

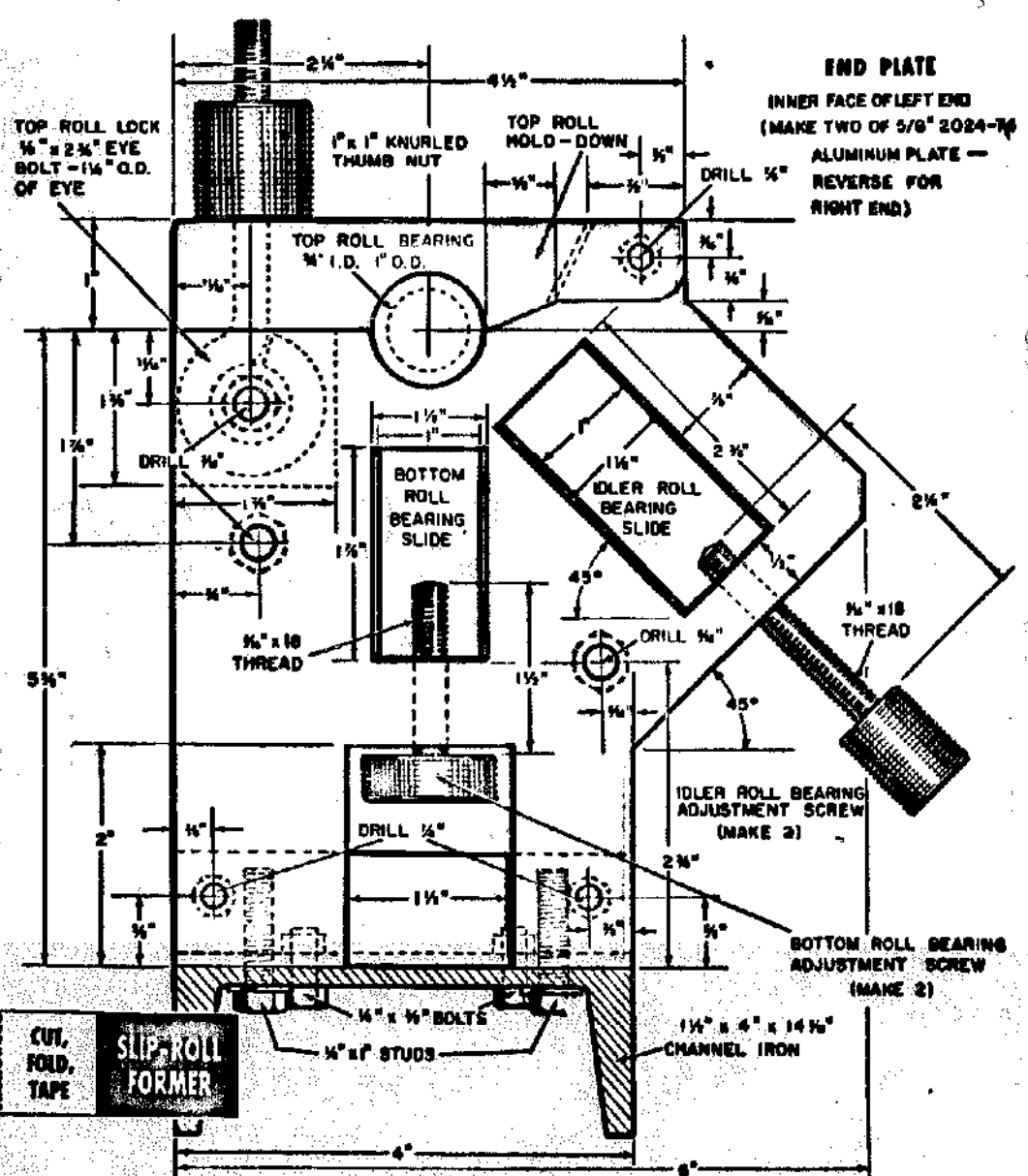

CUT, FOLD, TAPE
SLIP-ROLL FORMER

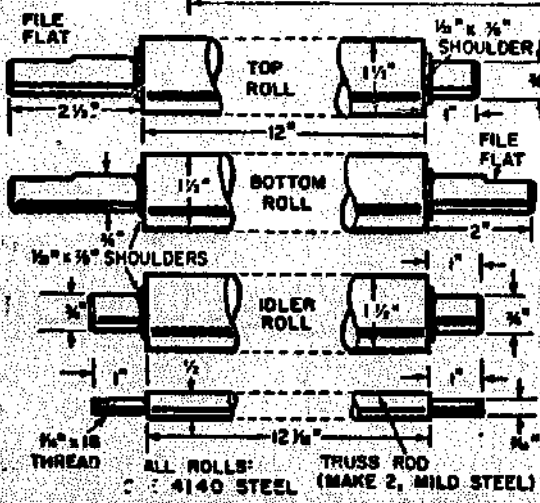

both plates, feeding the work to the cutter with the milling-vise crossfeed. Now mill the shoulder in the top plate's sockets, switch the grip bar to this top face and flip the unit over to mill the shoulders into the opposite face.

Next, re-bolt the plates (sketch E shows one method) to bore and ream the top roll bearing seat. The top of the plate is then sliced away and discarded. Whether you do this with a power saw or a hacksaw, cut through both plates at once. Leave the plates bolted together, also, for sawing the outer shape, then separate for milling the hinge studs and eye-bolt pockets to the dimensions shown at right.

ALL ROLLS: 4140 STEEL (MAKE 2, MILD STEEL)

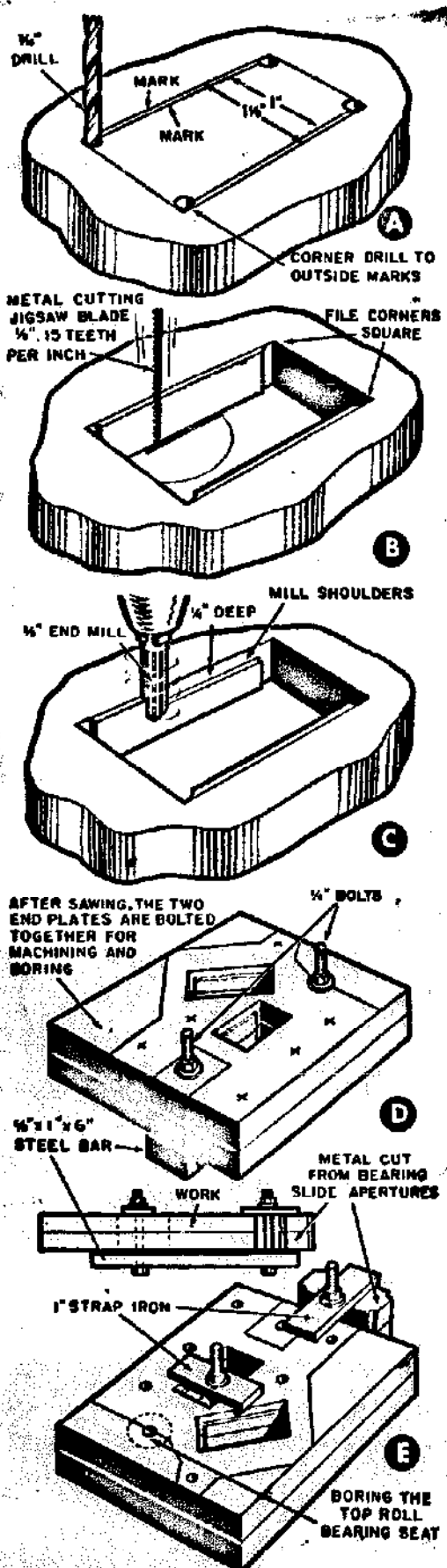

REMOVING FORMED CYLINDER is simple matter of unlocking top roll and lifting one end to slip cylinder free. Note base is clamped (or permanently bolted) to bench to handle overhangs and for clearance

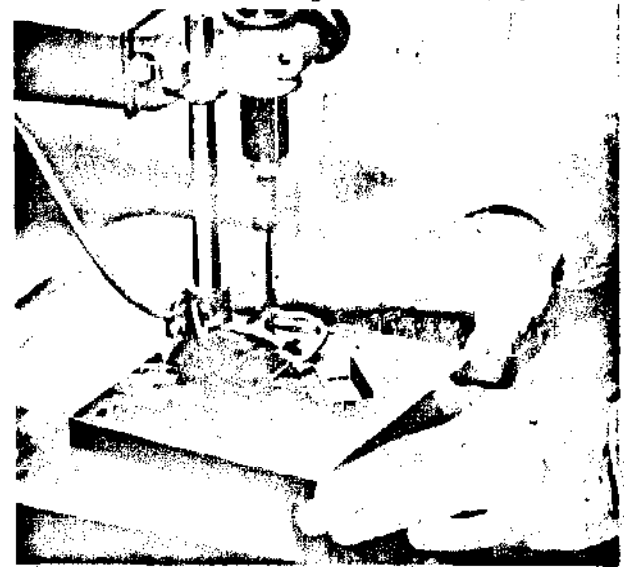

CUTTING BEARING SLIDE SOCKETS

- A** LAY OUT BOTH APERTURES on inner face of end plates as shown next page, then drill corners
- B** JIGSAW JUST INSIDE inner marks, then file or mill sawed edges for precision; square corners
- C** CUT 1/16-IN. SHOULDERS on drill press with work in milling vise to widen socket to 1 1/4-in.
- D** BEST MEANS of clamping both end plates for simultaneous machining: bolt on a grip bar
- E** BEARING SEAT for top roll can be cut in both plates at once by re-bolting bar, using waste

HOW TO FEED THE FORMER

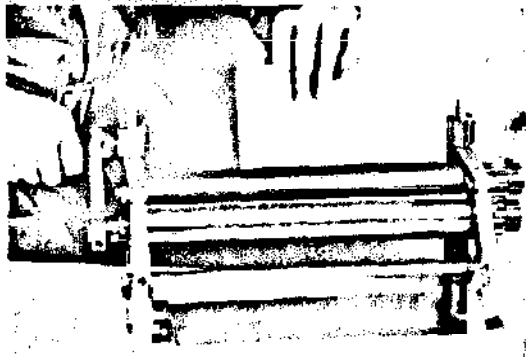

Light Gauge

SET IDLER ROLL FIRST, estimating proper position, then feed metal between two front rollers. Bend sheet upward with fingers, as shown in photo and Sketch 1, below. As you turn crank, metal will feed upward over idler roll by itself, as shown in Sketch 2. If curve is not sharp enough to form full circle, don't run work all the way through; turn crank backward to starting position, adjust idler roll upward, then roll work back through until ends meet each other

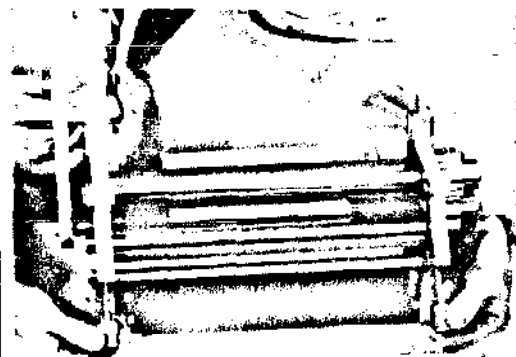
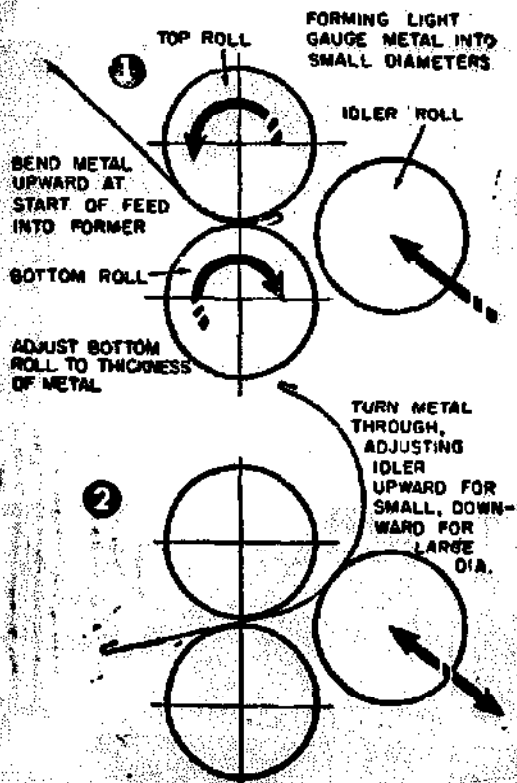

Heavy Gauge

START SHEET THROUGH front rollers until leading edge contacts retracted idler roll. Then raise latter by a few turns of adjusting screws, as shown in photo, and run metal through till trailing edge is about to pass through front rollers. Reverse action to bring leading edge back to starting position, then adjust idler up again. Repeat process, turning metal back and forth until idler has reached height that will curve leading edge around to meet trailing one

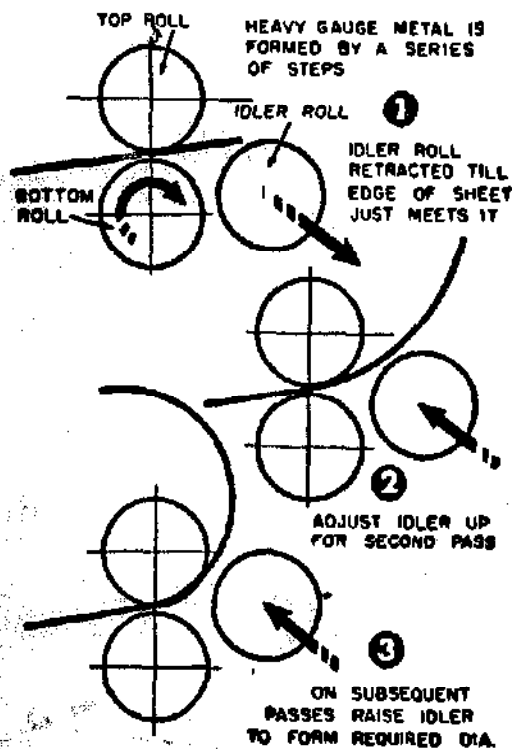

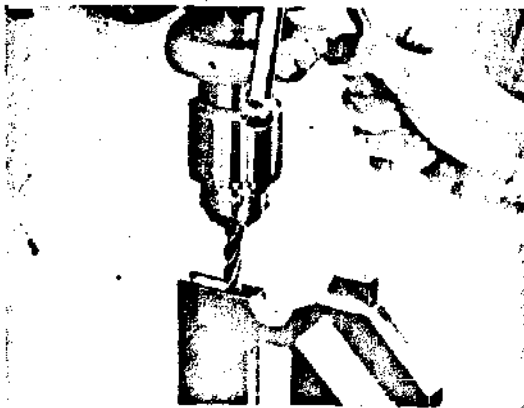
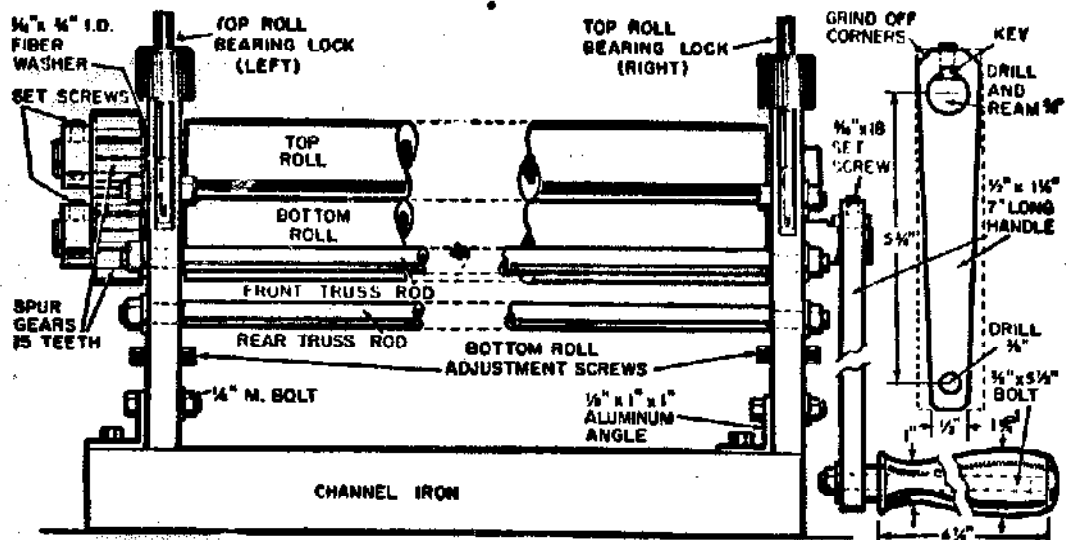

WHEN MILLING POCKET, avoid chatter by feeding work in .0005-in. steps and dropping cutter like a drill

BORE HOLD-DOWN for top roll on lathe, then cut on scratch line, discard bottom, mill cut edge of top

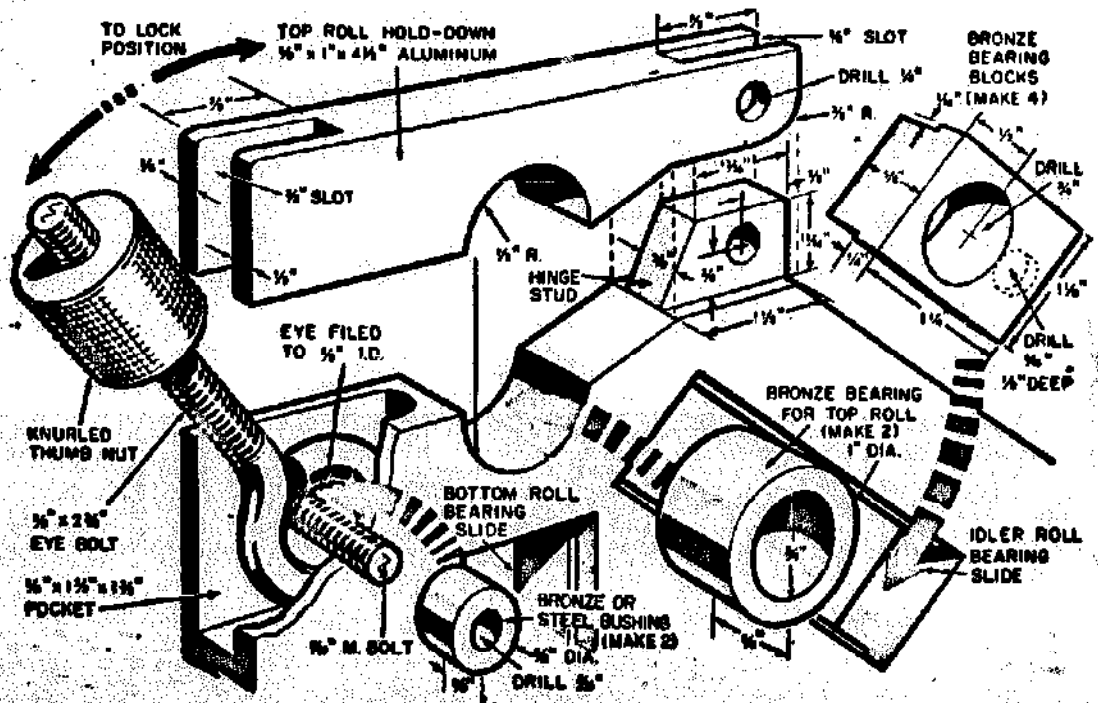



To make the two adjusting screws, fasten the knurled heads to the $\frac{3}{16}$ -in. brass-rod screws by tinning the rod's threads at one end and running the tapped head on while the work is hot. The thumb nuts for the hold-down locks are also knurled brass rod—center-drilled and tapped to fit the eye-bolt threads.

Make the three rolls to the specifications given on page 192; turn them to their maximum diameters ($1\frac{1}{2}$ in.) first, then decrease each end to the shaft diameter, (Please turn to page 226)

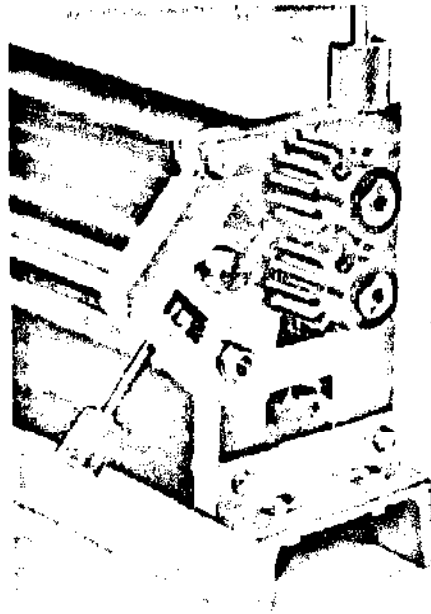

Material List

- 2 pcs. $\frac{3}{16}$ " thick 2024-T4 aluminum alloy plate, 6" x 6 $\frac{1}{2}$ "—end plates
- 2 pcs. $\frac{3}{16}$ " thick 2024-T4 aluminum alloy plate, 2" x 4 $\frac{1}{2}$ "—top roll hold-downs
- 1 pc. $\frac{1}{2}$ " thick x $1\frac{1}{4}$ " wide x 7" long 2024-T351 aluminum bar stock—handle
- 3 pcs. 15 $\frac{1}{2}$ " steel rod, SAE 4140, 14", 15 $\frac{1}{2}$ " and 16 $\frac{1}{2}$ " long—rolls
- 2 pcs. $\frac{1}{2}$ " mild steel rod, each 14 $\frac{1}{4}$ " long—truss rods
- 1 pc. 1 $\frac{1}{2}$ " x 4" x 14 $\frac{1}{4}$ " channel iron
- 4 pcs. bronze, $\frac{3}{8}$ " x $1\frac{1}{4}$ " x $1\frac{1}{4}$ "—adjustable bearing blocks
- Two eyebolts, bolts, nuts, lockwashers and brass rod as called for in plans
- Two Boston Spur Gears, No. NF-15B, 15 teeth, 1.50 pitch dia.; $\frac{3}{4}$ " bore; 1" face; 10 pitch; 14 $\frac{1}{2}$ " pressure angle, $\frac{3}{8}$ " hub projection

NEXT MONTH IN SHOP AND CRAFTS

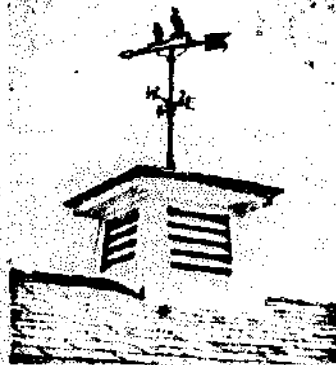

Add a cupola to your garage. More than just decorative, a louvered cupola provides an escape hatch for the excessive heat build-up under the roof. You'll find complete plans for building three different styles in a March craft feature.

Vertical spinning wheel. Fast becoming a collector's item, this reproduction of a rare antique makes it a fine project for the lathe enthusiast and the lover of fine old pieces of another era.

Self-Reading shop gauge. A unique pistol-grip caliper which lets you take any O. D. measurements—even where the workpiece is turning. You'll want to make one to hang by your lathe or workbench.

SHEET METAL FORMER

(Continued from page 195)

remembering to lathe a small shoulder at both ends to serve as a clearance "washer."

Naval bronze is best for the sliding bearing blocks, since it is long-wearing. Rough-cut the blocks, then mill them in your lathe milling attachment to maximum outside dimensions. Make all four $1\frac{1}{4}$ in. long, but fit each one individually to the width of its own slot, using metal number stamps to key them. Also stamp corresponding sockets and the shaft ends of the bottom and idler rolls (such numbers can be seen at the ends of the shafts on page 195). This aids precision assembly.

Form the shoulders with your lathe milling attachment, making a rough, undersized, one-pass cut to start. Try the block in its socket and use a dial indicator to shave down each side until the block fits without binding.

The bottom roller adjusts up and down to match roller spacing to the thickness of the metal being worked. If your cylinder is to have a lock joint, turn the locks on the metal first and adjust the bottom roll so it will just pass the lock without squeezing it shut. The adjustment of the idler roll, of course, alters the diameter of the cylinder to be formed.

The rig will form semi-cylinders or troughs, as well—in case you want to make a section of half-round eaves gutter. This same shape can be put into the middle of a length of sheet metal by fully retracting the idler roll and feeding the metal through flat to the point where the curve is to begin. Adjust the idler upward and roll the work back and forth the length of the curve until it bends back on itself, bringing the straight sides parallel. Such a shape is useful in the shop as a cover for shafting, gears or pulleys. ★★★

X606

AT MICROFICHE REFERENCE LIBRARY

A project of Volunteers in Asia

Sheet-Metal Brake Popular Mechanics No. X606

by: Manly Banister

Published by:
Popular Mechanics
224 West 57th Street
New York, NY 10019 USA

Paper copies are \$ 2.00.

Available from:
Popular Mechanics Plans, Dept. 77
Box 1004, Radio City
New York, NY 10019 USA

Reproduced from Popular Mechanics. (c) The Hearst Corporation. All Rights Reserved.

Reproduction of this microfiche document in any form is subject to the same restrictions as those of the original document.

ROLLER-ACTION X606 SHEET-METAL BRAKE

PART 1

By Manly Banister

SHEET-METAL WORK can be either fascinating or frustrating—it all depends on the sort of a bending rig you use to do the job. In most home shops, metal bending is done in the simplest possible way: the work is clamped so that it overhangs the edge of the bench and is then hammered with a mallet to produce the

desired bend. For occasional basic jobs there's nothing wrong with this method, but there's no denying that the results are crude and the types of bends that can be made are limited. The man who takes his shop work seriously won't be satisfied with such primitive techniques. He'll want a heavy-duty metal brake capable of mak-

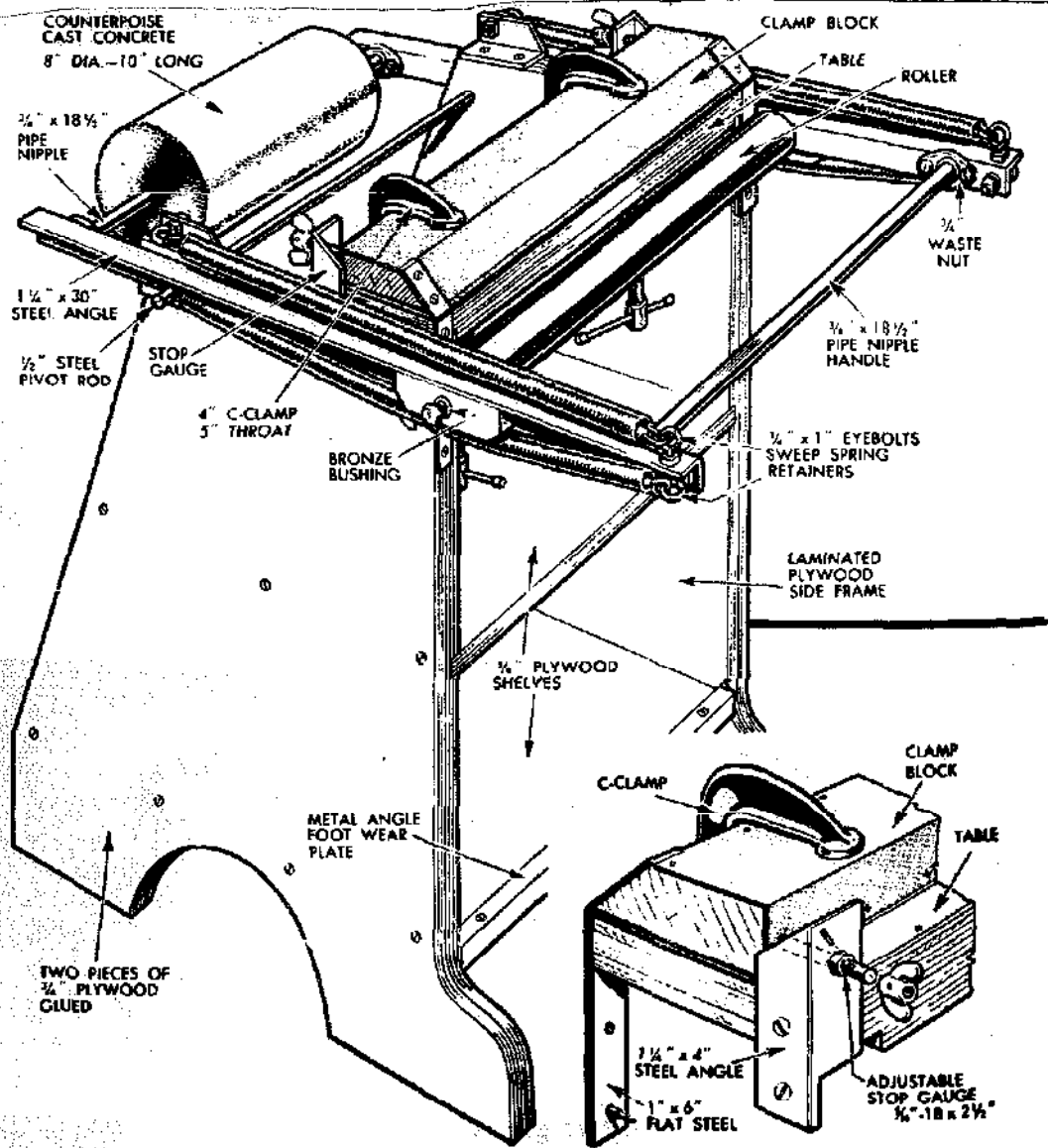

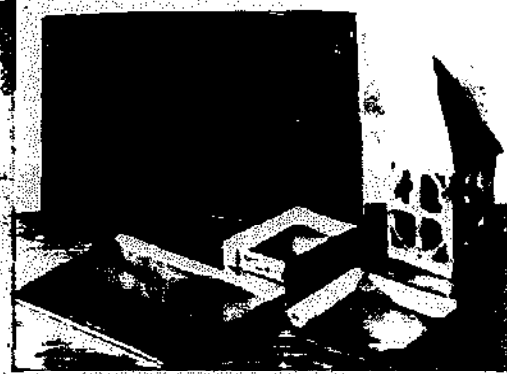

COOKIE SHEETS, flowerpot trays and a garden lantern are just a few of the projects that can be turned out on this sheet-metal brake. Bending is simply a matter of forming metal over a suitable mold



ing clean, precise bends, seams and coves.

The machine shown on these pages really fills the bill. Its design departs from conventional sheet-metal brakes by employing a steel roller instead of a bending leaf. This feature extends the versatility of the machine greatly because the roller can be worked both downward and upward, providing exceptional latitude in project design. By using the proper forming block or mold, you can bend sheet metal to any angle, make radius bends, reverse bends and seams.

The machine's construction is rugged enough to permit bending 20-ga. sheet iron the full 18-in. width of the table, though material of this size and thickness will require the aid of a mallet to "sharpen" the bend. Lighter metals, and narrow widths of heavy-gauge stock, can be bent

easily. For example, $\frac{1}{8}$ x $2\frac{1}{2}$ -in. strap aluminum can be bent sharply with a single stroke.

A 4 x 8-ft. sheet of $\frac{3}{4}$ -in. plywood will provide enough material to build the frame and table. Both the table and the two sides are constructed by gluing two pieces of plywood together. The double thickness of these pieces, plus the bracing effect of the shelves, which are attached with glue and screws to the sides, assures rigidity. Lag screws are used to attach the table to the frame, making it a simple matter to remove the table for replacement.

To insure accuracy, both side pieces should be clamped together and drilled at the same time for the pivot shaft. A 2-in. square steel plate, set into a snug-fitting recess chiseled in each side piece, serves as a bearing for the shaft.

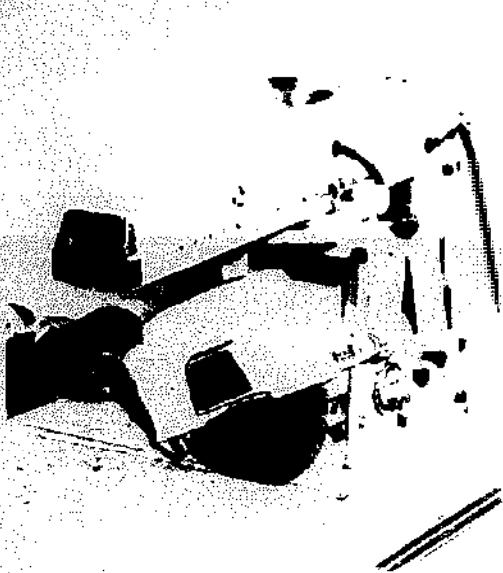

IT'S NO TROUBLE to dado the shelf grooves in the sides of the frame if you make the cuts while the stock is still square, before bandsawing it to shape



THE SIDE MEMBERS of the frame are brought to their finished form with a bandsaw. Large work is easier to handle if you rig up an auxiliary table as shown

The top of the table is faced with a piece of 14-ga. sheet steel attached with countersunk F. H. wood screws. The bottom is covered with 20-ga. sheet steel. To begin with, you will need only one clamp block, shaped as shown in the drawing. You will have to bend the sheet metal cover by hand, but after that all your bending can be done on the machine itself.

The roller may be made of cold rolled steel, though you'll find that hot rolled steel costs less and is as serviceable. Use your lathe to remove the scale and true the ends; then, if you have a tool-post grinder, use it to grind the surface. Otherwise, careful filing while the work rotates in the lathe will smooth the surface sufficiently. The holes to be drilled and tap-

ped in the ends of the roller must be perfectly centered.

Two oak bearing blocks with $\frac{1}{2}$ -in. bronze bushings are fastened with screws to the steel-angle sweep. A machine bolt passed through the bushing secures the end of the roller and allows easy removal should the roller require refinishing.

The counterpoise should weigh about 45 pounds. A concrete cylinder will do the trick or you may prefer to use barbell weights.

The springs are a standard item. They are 16-in. long, 1-in. outside dia., and are of 12-ga. wire. Stretched to a length of 22 in., they each provide a 25-pound pull.

In the November *PM* you'll learn how to put the brake through its paces. ★ ★ ★

METAL-CUTTING SAW makes short work of a tough job, cutting the 14-ga. sheet metal top. If you lack this tool, a sheet metal shop can do the work for you.

THE SOLE PLATE for the clamping block is 14-ga. sheet steel. The leading edge of the metal should be ground to a 45-deg. angle and then finished with a file.

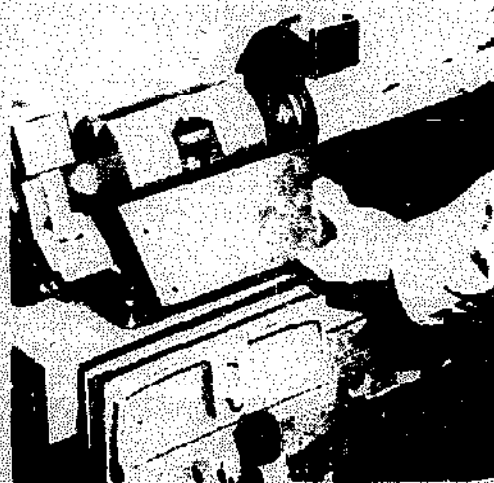
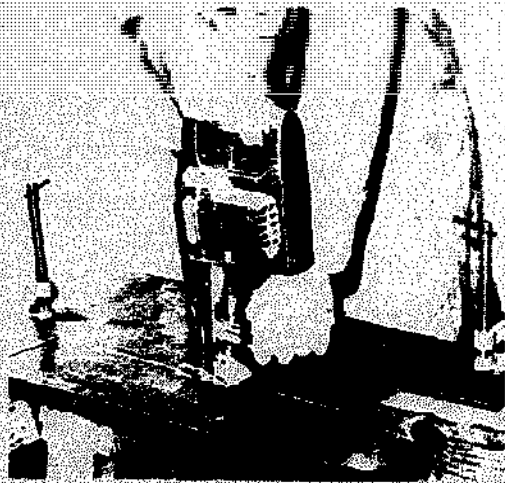

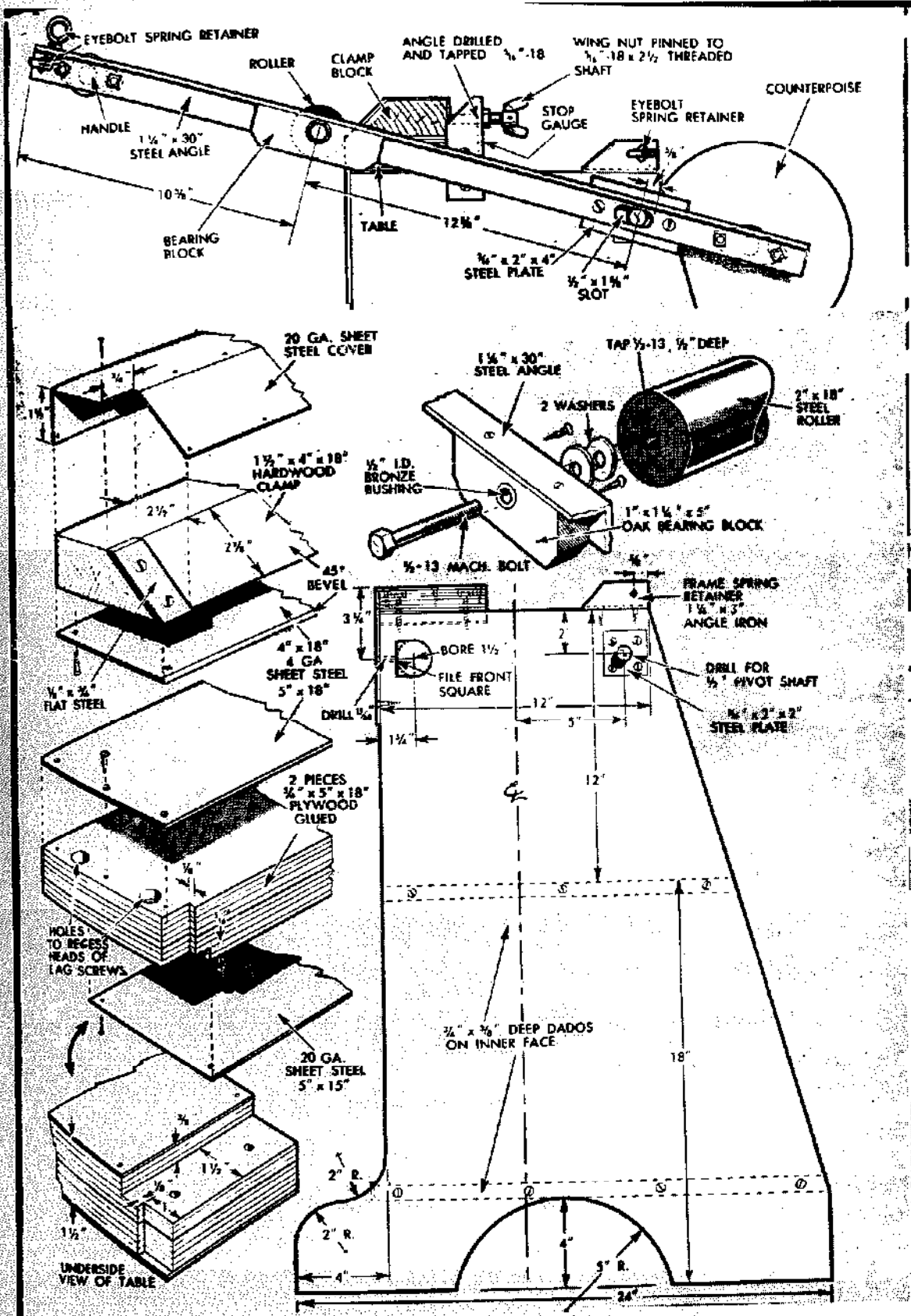

TO ASSURE bends square with the edge of the metal, check placement of the work with a try square held against the beveled holddown block used in most bending



WITH its main beveled clamping block, plus additional bending forms of special shapes which are used either in conjunction or separately, you'll be able to make just about every bend possible with your new roller-action sheet-metal brake. It's simply a matter of selecting the proper clamp block or molding form. After you've done that, just keep in mind the golden rules of brake operation: Make

RADIUS BENDS up to $\frac{3}{8}$ in. can be made by bolting a $\frac{3}{4}$ -in. hardwood board (with top edge rounded) across front of brake and bringing roller downward

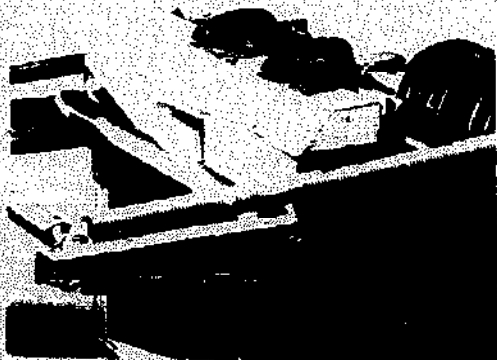

square bends by bringing the roller downward and bending the metal over the edge of the table; use a downward motion for bends over the molding forms, and finally, for bends formed with the clamping block, bring the roller upward. That, in a nutshell, is about all you'll need to know in order to be able to do basic work, but let's consider a few fine points:

Metals, particularly in the heavier gauges, tend to spring back slightly after bending. You can compensate for this by bending the work about 5 deg. more than is desired. The easiest way to do this is to bevel the forming block an additional 5 deg. or you may prefer to increase the bend by simply tapping it with a mallet.

Large work that exceeds the capacity of the clamp blocks can be handled by using a little ingenuity. A long rectangular tube, for example, can be made in sections.

A worthwhile precaution when working with soft metals is to slip a piece of paper between the roller and the metal to prevent marring.

As is true in any shopwork, nothing can replace actual experience. In working with your brake, you'll soon work out your own setups. ★★★

FORMING SINGLE AND DOUBLE HEMS

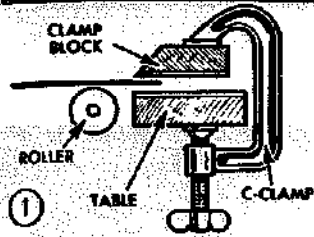

① INSERT SHEET METAL TO DEPTH OF FOLD AND CLAMP

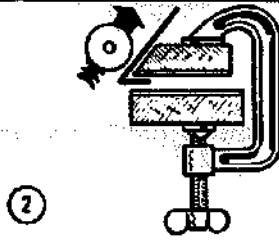

② LIFT SWEEP TO RUN ROLLER UPWARD, FORMING THE LOCK

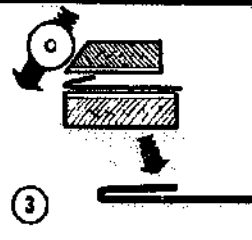

③ REMOVE CLAMPS AND RUN ROLLER DOWNWARD TO FORM SINGLE HEM

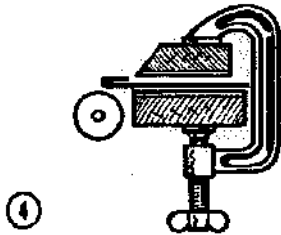

④ CLAMP METAL WITH HEM OUTSIDE

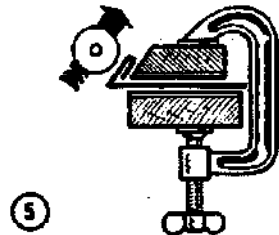

⑤ AND RUN ROLLER UP

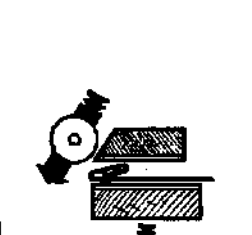

REMOVE CLAMP, THEN RUN ROLLER DOWNWARD TO FLATTEN AND FORM THE DOUBLE HEM

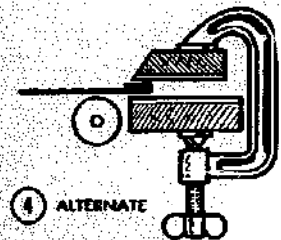

④ ALTERNATE
INSERT HEM UNDER CLAMP

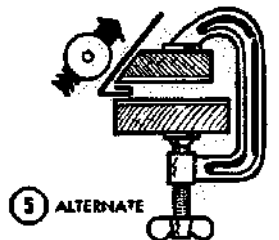

⑤ ALTERNATE
RUN ROLLER UP

SINGLE HEM is made along edge when two sheets of metal are to be joined—or to eliminate a sharp edge. A double hem is made to provide additional strength and to add a finished look

MOLDING FORMS SIMPLIFY TRICKY BENDS

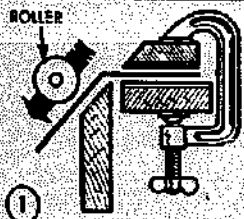

① BENDING A LESS THAN 90° ANGLE WITH FORMING MOLD

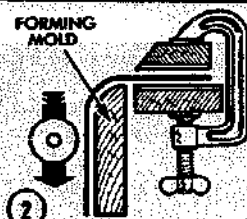

② MAKING A RADIUS BEND WITH THE SWEEP (UP TO 3/4" RADIUS)

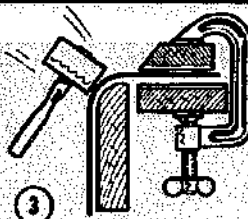

③ BENDS LARGER THAN 3/4" ARE HAND MADE USING Mallet OR HAMMER

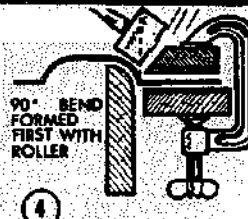

④ 90° BEND FORMED FIRST WITH ROLLER
REVERSE RADIUS BEND USING MOLD AND Mallet

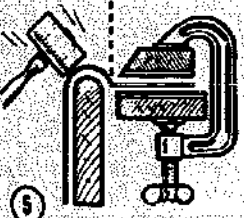

⑤ FORMING A COVE WITH FULL ROUND MOLD

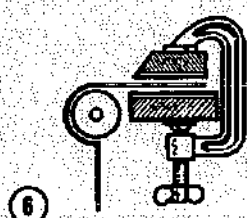

⑥ ROLLER IS FORM FOR LARGE-RADIUS COVES
SUBSTITUTE PIPE FOR SMALLER ONES

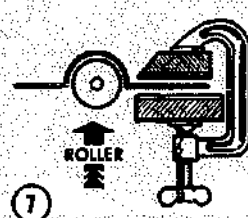

⑦ AFTER RADIUS BEND RAISING ROLLER (OR PIPE) COMPLETES COVE

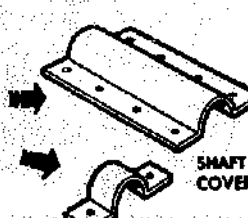

PIPE CLAMP

CONTINUED

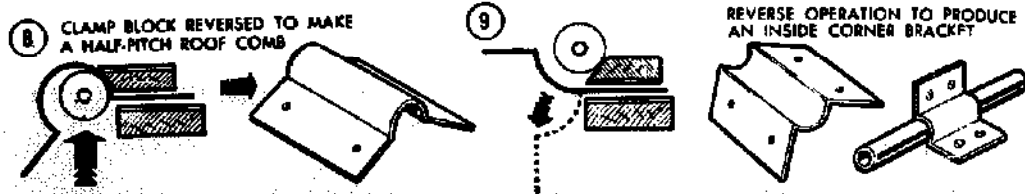

FORMING A BOX WITH SOLDERED CORNERS

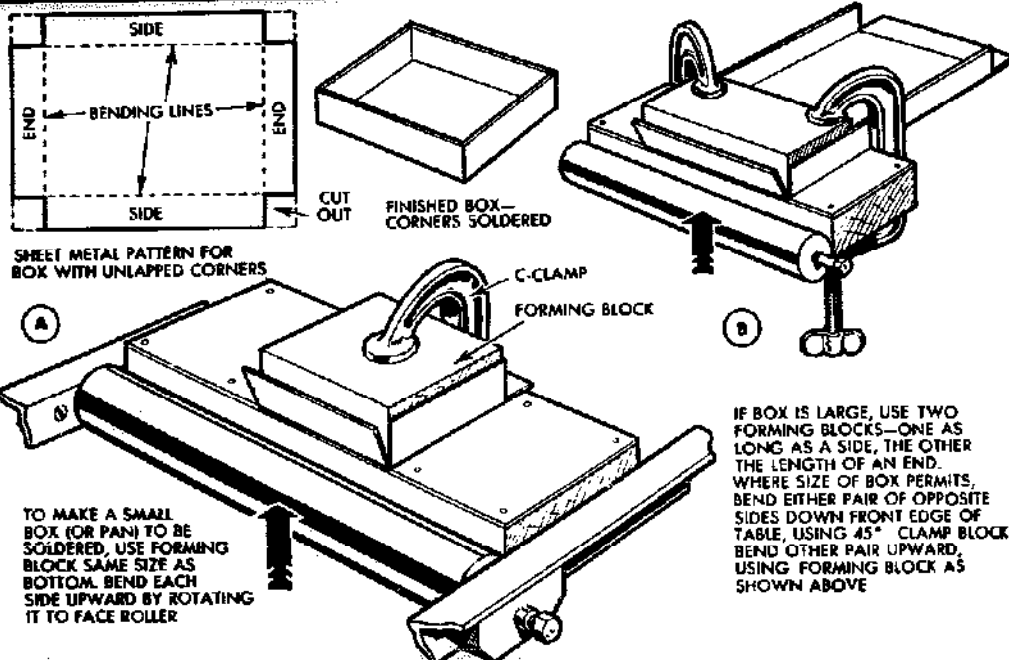

FORMING A BOX WITH RIVETED CORNERS

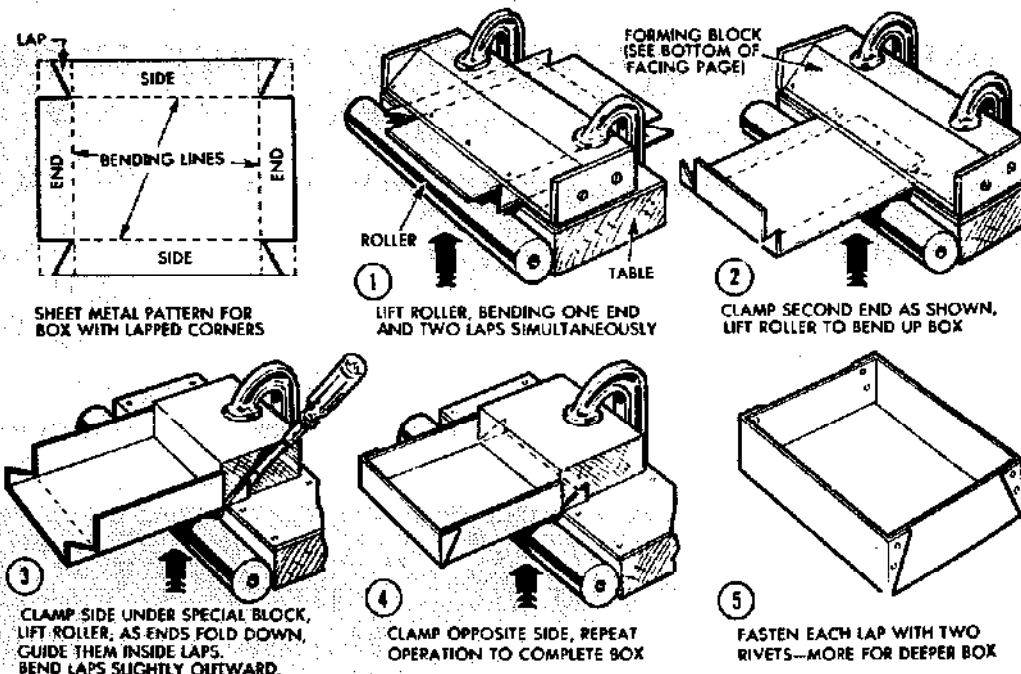

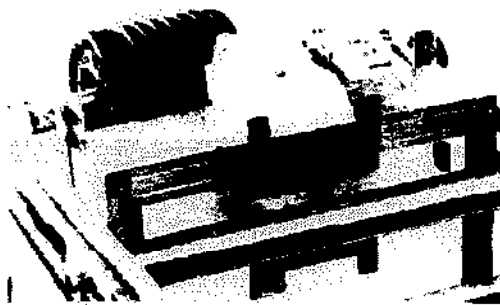

ALTERNATE METHOD of forming lap-corner box. Here ends between corner tabs are clamped first with beveled hold-down block for downward roller action

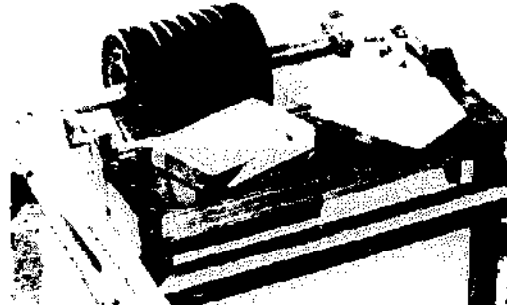

SIDES OF BOX are bent up around same hold-down block with upward sweep of the roller, then corner tabs are bent over ends with mallet, for fastening

EXTRA BLOCKS — AND THE BENDS THEY MAKE

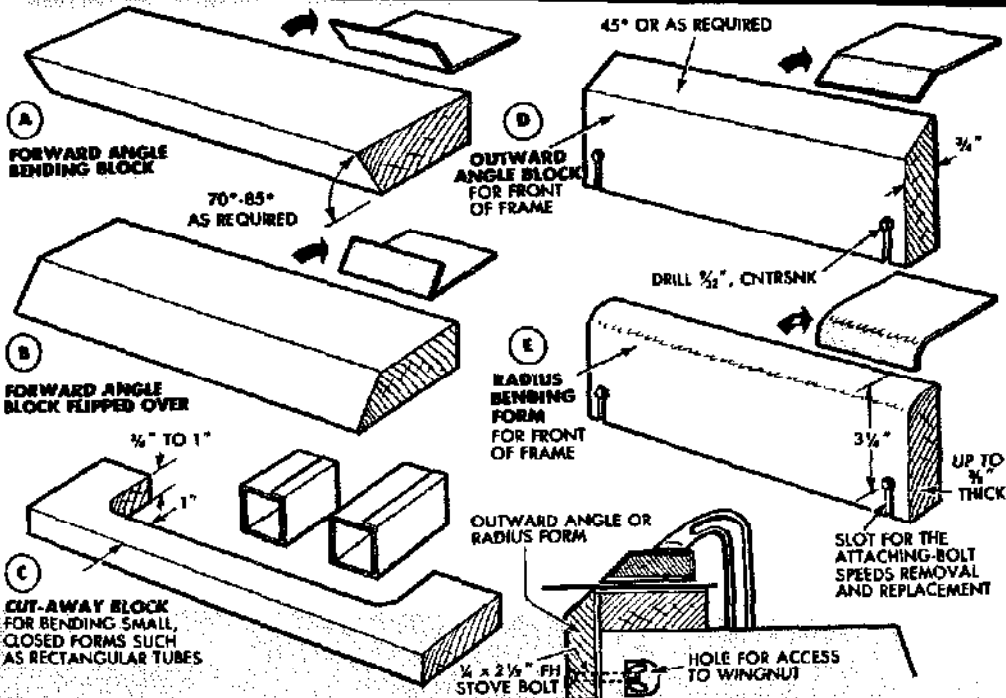

RECESSED FORM is a versatile accessory. It can be used to construct boxes and bend narrow channels

UPWARD MOVEMENT of roller combined with a 90 deg. recessed bending form produces precise channel

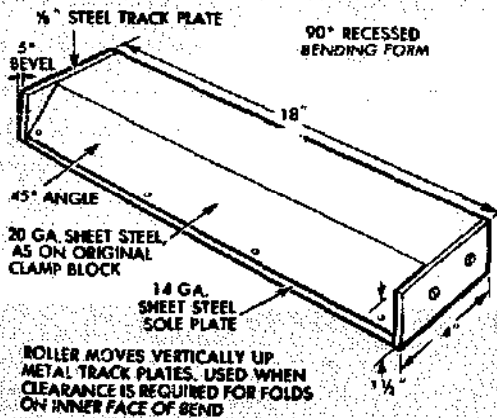

ROLLER MOVES VERTICALLY UP METAL TRACK PLATES. USED WHEN CLEARANCE IS REQUIRED FOR FOLDS ON INNER FACE OF BEND

