

# Construction manual for a creté windmill

By N.J. van de Ven



**WOT**

WORKING GROUP  
ON DEVELOPMENT  
TECHNIQUES

P.O. BOX 217  
7500 AE ENSCHEDE  
THE NETHERLANDS



CONSULTANCY SERVICES  
WIND ENERGY  
DEVELOPING COUNTRIES

P.O. BOX 85  
3800 AB AMERSFOORT  
THE NETHERLANDS

CONTENTS	PAGE
INTRODUCTION	7
1. THE WOOD-WORK LATHE	9
1.1. Assembly	9
1.2. Transmission	9
1.3. Operating the lathe	12
2. THE BOREHOLE AND THE PUMP	15
2.1. Making the borehole	15
2.2. The piston-pump	20
2.3. The foot valve and the piston	21
3. THE WINDMILL	25
3.1. Constructing the tower	25
3.2. The foundation, the erection of the tower and the alignment	28
3.3. The head construction	30
3.4. The moving parts	36
3.5. Brake construction and control	40
3.6. The rotor	44
3.6.1. The sail frame, the rotor support	44
3.6.2. The sails	47
3.7. Assembly of the head construction and the rotor	50
3.7.1. Mounting the head construction	50
3.7.2. Mounting the rotor	51
3.8. Finishing and testing the mill	53
Annex Material	57

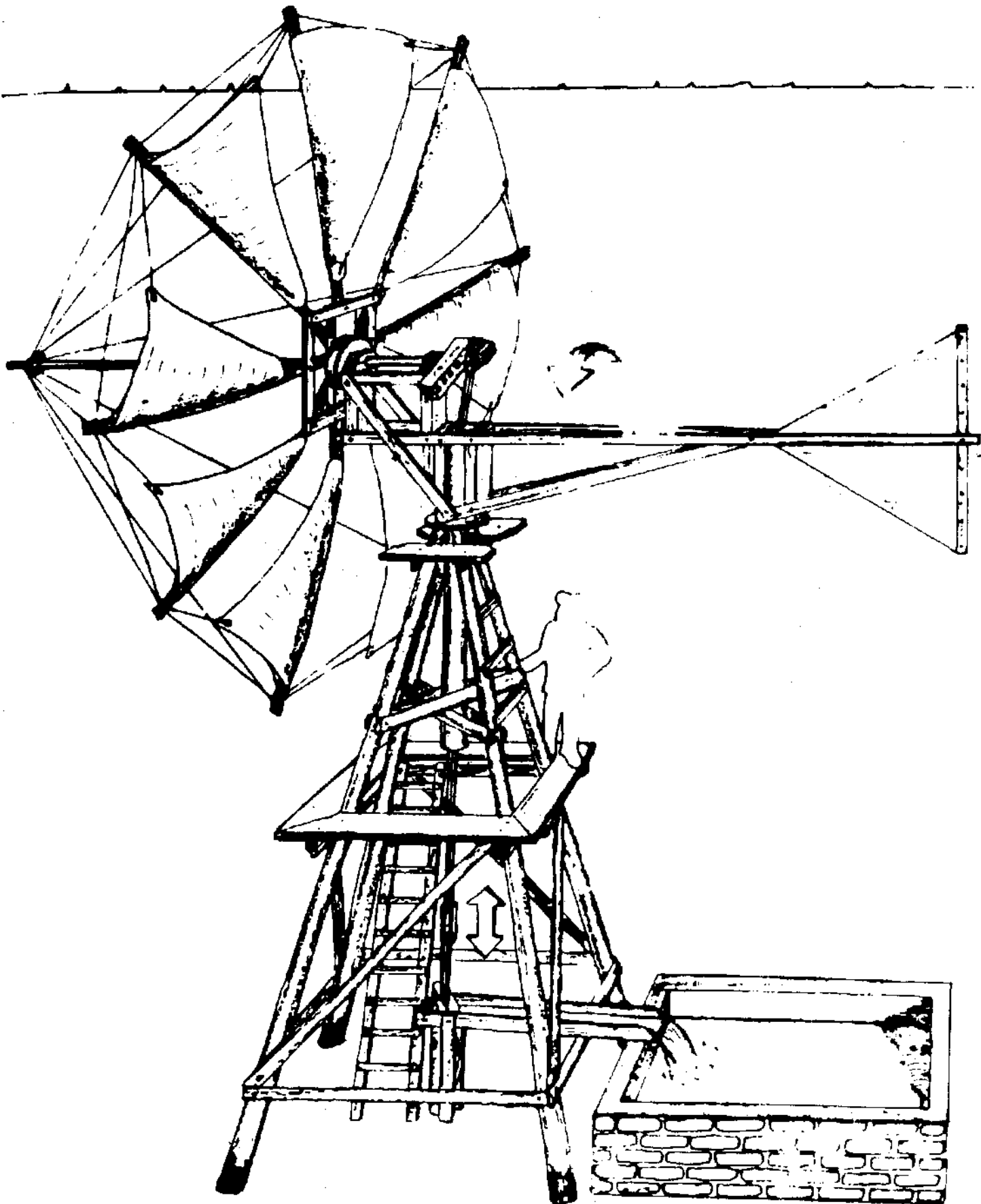

## INTRODUCTION

The designs described here, for a wood-work lathe, a piston-pump and a slow running (sailwing) windmill have an intermediate technological character.

That is to say our aim has been to make designs which can be entirely constructed from materials which are available everywhere, e.g. logs, rugged sawn wood and piping.

Connections have been made using wood screws (sometimes telephone pole bolts) and pieces of threaded bar (commercially obtainable in lengths of 1 m: M8, M10 etc.).

When these materials are not available, use can be made of mortise joints, possibly in combination with glued and rope-tied joints.

However, the latter type makes higher demands on both the tools available and the skill of the constructors.

We only used manual tools (e.g. chisels, handsaws, handdrills, hammers etc.) to assemble the prototypes of the equipment.

We have tried to describe our experience as equipment builders as clearly and systematically as possible.

## 1. THE WOOD-WORK LATHE

Since the piston-pump needs circular parts (valve and piston body) we decided to build a lathe for wood-work. The lathe is made from rough wood left over from previous projects, mainly, Connections are made with screws, nails, lengths of threaded bars and bicycle parts. The lathe is easy to use and is turned by foot treadle.

### 1.1. Assembly

Figure 1.1. shows the assembly of the lathe. The frame consists of two parallel beams which form the support for the tool rest and the tail-stock, both of which can be fixed to the horizontal beams with wooden clamps.

The headstock consists of two upright pieces of timber, one of which acts as a post.

A ball-head, sawn from a bicycle frame, is clamped into a groove in the ends of the headstock, using a loop of wire or a bracket of metal strip, thus forming a revolving headstock spindle.

As the legs of the fork have been sawn off the ball-head, a large circular disc can be screwed onto the top of the fork (fig. 1.2.).

This disc is centred on the centre point; this is a piece of pipe that fits into the centre tube of the fork and can be fastened there.

Teeth are filed in the projecting end.

The wooden disc should preferably consist of plywood or a similar type of layered wood. This can be made by laying several planks across each other, nailing or glueing them together and then sawing out the disc. Aim of the disc is twofold: to fix the object to be turned, if this is not turned between the centres (disc shaped objects), and to act as a fly-wheel.

Since the lathe is driven by a pedal-crank mechanism, the disc is essential and should be as large as possible.

The assembly of the tool rest and the tailstock with their locking devices may be seen from the drawings.

### 1.2. Transmission

A bicycle wheel fixed to a crank is driven by means of a bicycle foot pedal placed on the long axis of the frame. The drive is transmitted by a flat belt (cut from the profiled surface of a bicycle tire) to a wooden disc that is coupled to the spindle. A transmission ratio of 1 : 4 has proved to be the most satisfactory.

It is advisable that the wooden pulley has a spherical shape to prevent the belt from slipping off it.

There are several ways of attaching a crank to the bicycle wheel. In fig. 1.1. this has been done by clamping two pieces of timber in one line between the rim and on either side of the hub. These two pieces of wood balance each other.

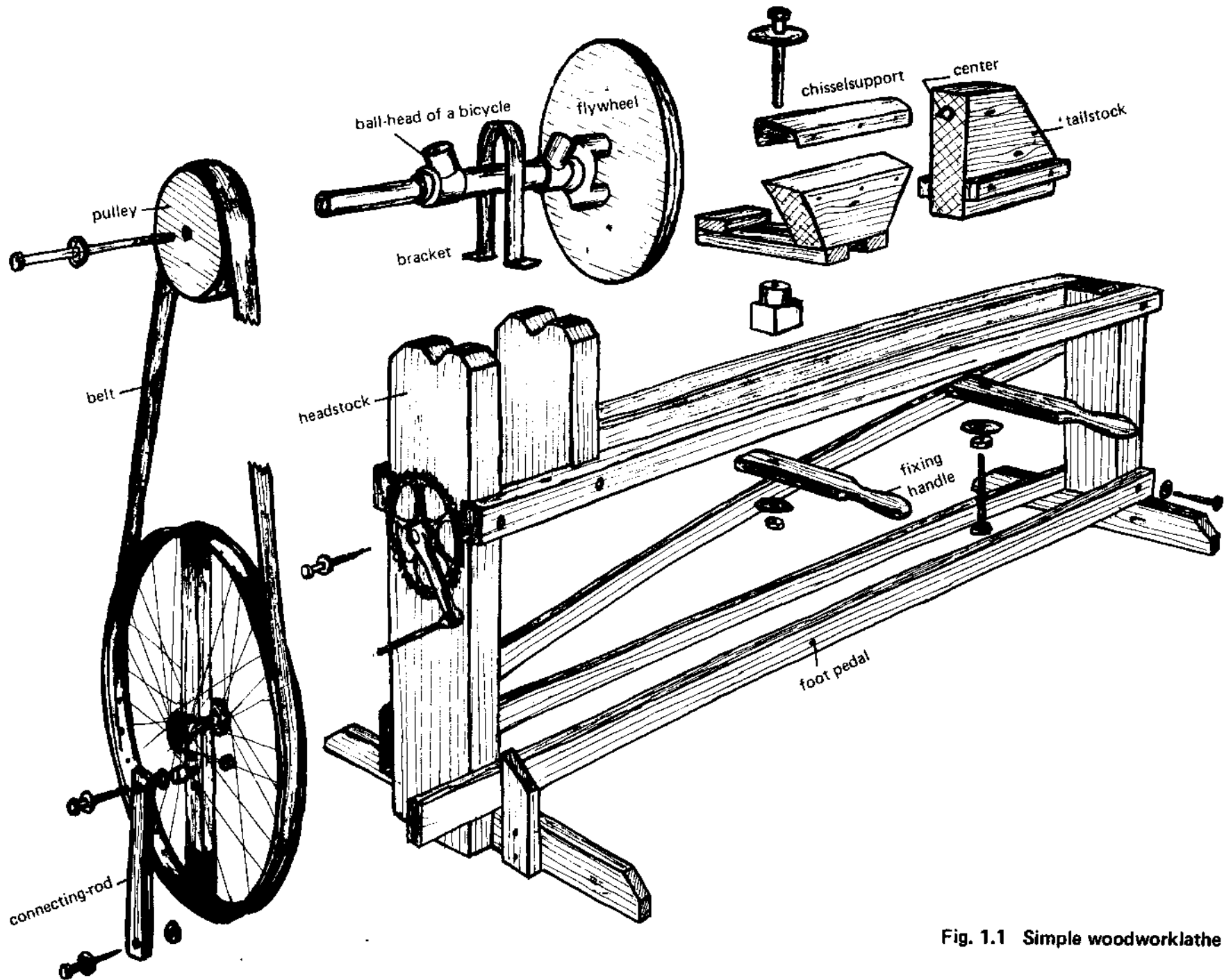

Fig. 1.1 Simple woodworklathe

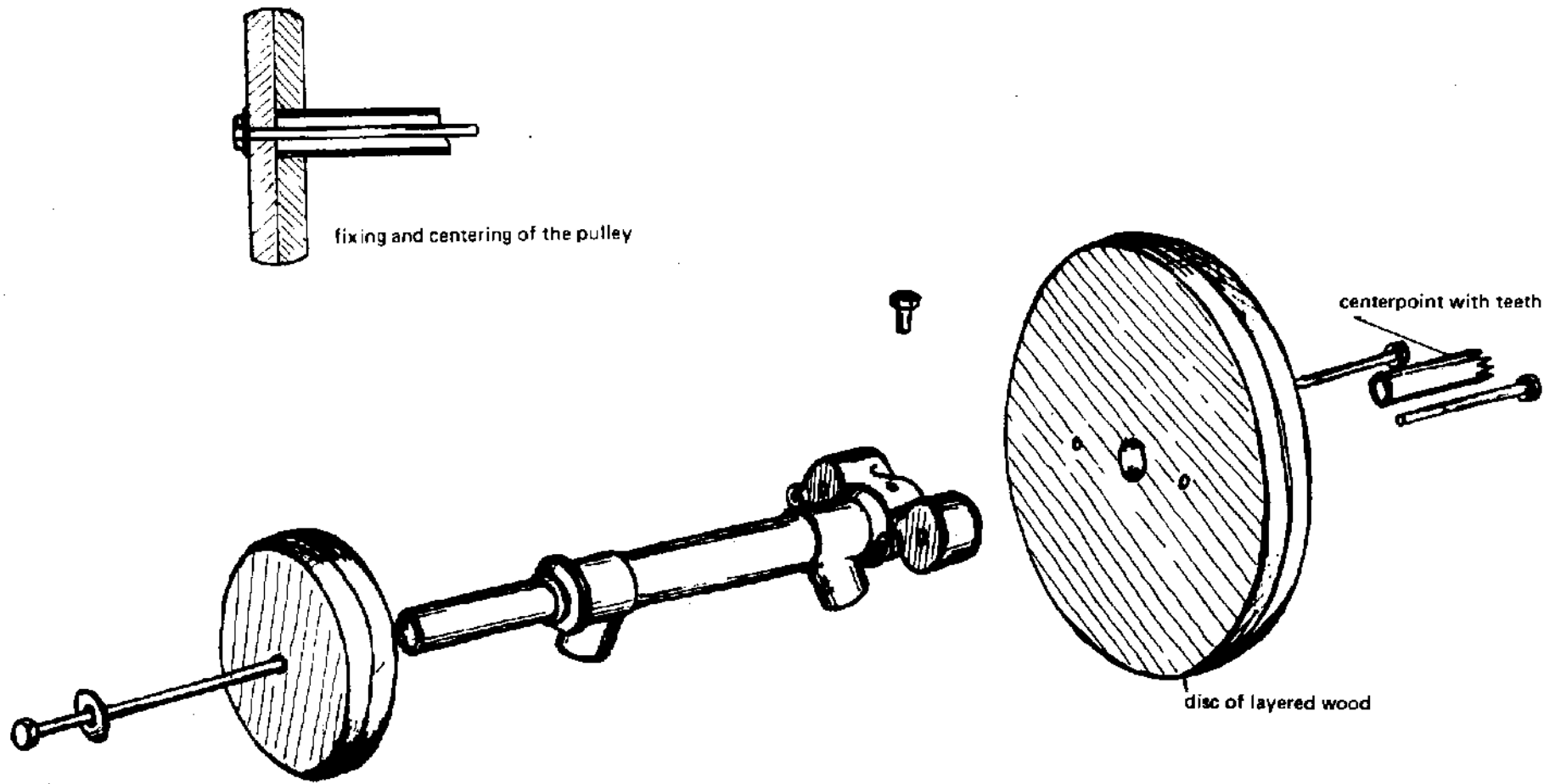
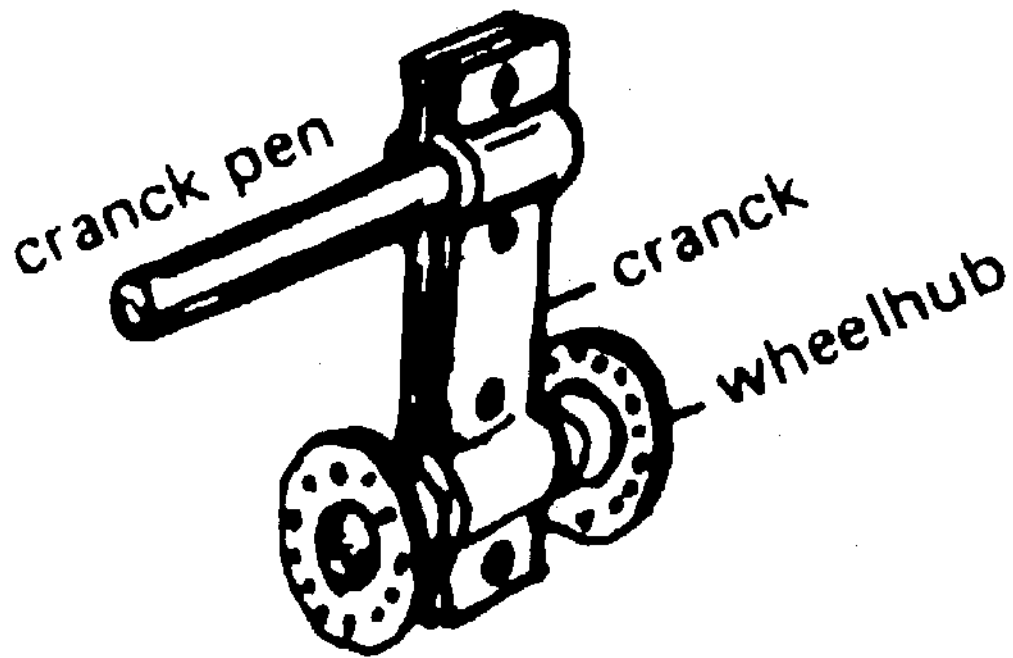

Fig. 1.2





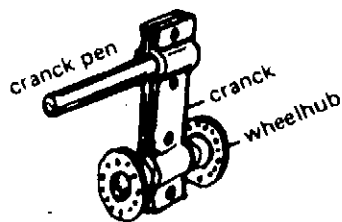

Fig. 1.3

The handle should be about 6 cm long, but experiments can be carried out using one's own judgment.

### 1.3. Operating the lathe

We distinguish between two kinds of pieces to be turned: long thin ones and disc-shaped ones. The former are fixed between the fly-wheel and the tailstock. It is advisable to make a centre point, in the form of a small conical hole of a few millimetres deep, at the end of the workpiece before fixing it.

This may be done using a nail punch or similar instrument. The pointed handle of a file is another alternative.

Then the front of the workpiece is placed against the serrated driven centre point and hammered into it with several firm hammer-blows against the rear end.

The tailstock is then screwed on and fixed with slight pressure against the workpiece. A disc-shaped workpiece is centred as accurately as possible on the large wooden fly-wheel and then firmly screwed to it.

The tool rest is placed as near as possible to the surface to be turned so that the cutter bears as far as possible on the tool rest and not on the hands.

Since the lathe operator stands on one leg to operate the lathe, he must also be able to lean on the tool rest and still be able to handle the cutter correctly (fig. 1.4.)

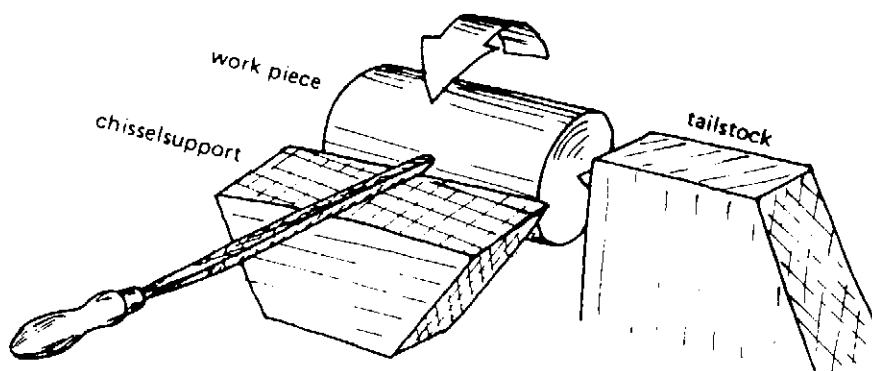
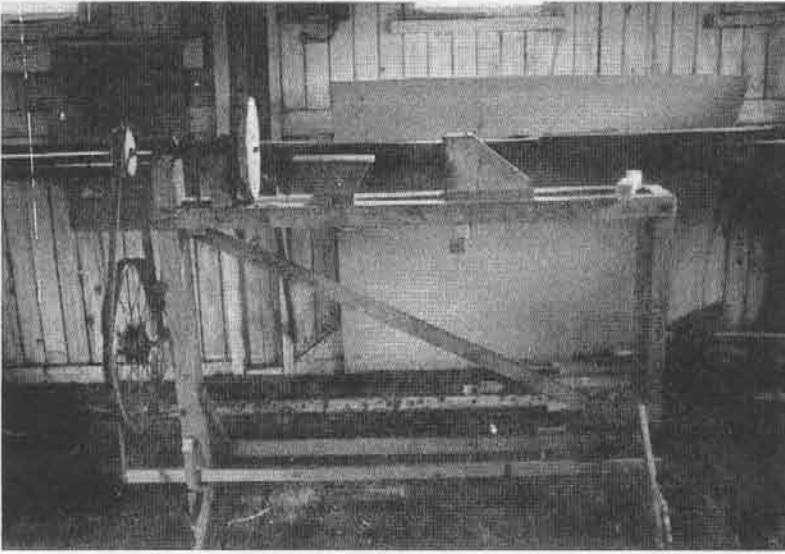
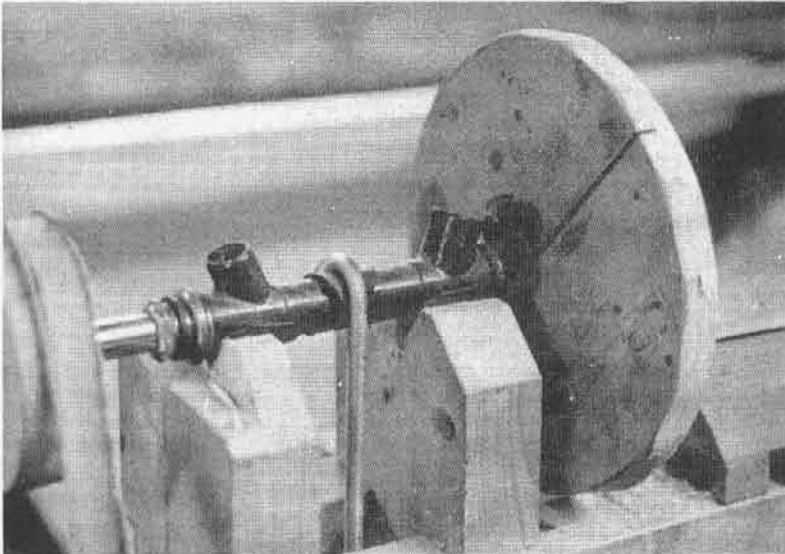

Fig. 1.4



de houtdraibank  
the lathe



de hoofdspil en het vliegwiel  
the spindle and flywheel

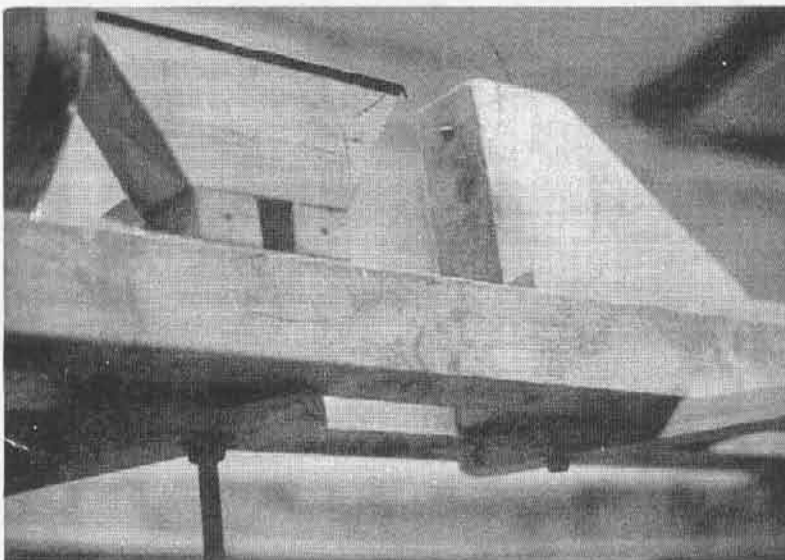

de leunspaan en de losse kop  
support, bed and centerhead

It is clear that the operator needs a steady hand; it is also a question of "practice makes perfect".

It is possible that none of the more professional cutting tools will be available. A simple and adequate tool can be made from an (old, blunt) file; preferably one with a square cross section.

The file is sharpened with the aid of a grinding stone, as shown in fig. 1.5.

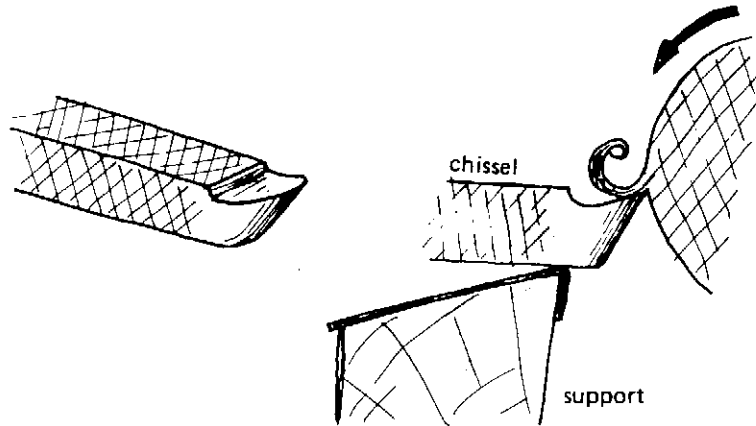

Fig. 1.5

If the cutter starts to "bite" or jump during turning, it must be held at a slant, that is with the handle raised. The cutting process then has a scraping character.

In this way very smooth workpieces can be obtained which can be finished or smoothed to size with sandpaper, if necessary.

In general, smoother surfaces are obtained on harder and short grained timber.

However, the final result is largely dependent on the skill and experience of the lathe operator.

## 2. THE TUBEWELL AND THE PUMP

To obtain the most efficient coupling of the windmill and the piston-pump the windmill is constructed directly above the well.

In this way the pump can be connected direct to the mill. When a piston-pump is used the revolving motion of the millshaft has to be transposed in a reciprocating movement of which the stroke can be adjusted. The reciprocal motion of the vertical piston rod is then transmitted direct to the plunger of the pump.

The water is pumped out through the pump outlet into a gutter which leads to a storage tank.

Since the mill can pump an amount of approx. 100 l per minute with the pump used, we had to return the pumped water to the tubewell by way of a backflow pipe from the storage tank.

This type of a mill will be built above a well or underground river, but as already remarked these did not exist on our site.

### 2.1. Making the borehole

The bore hole should be approx. 4,5 m deep with a diameter of approx. 200 mm. Drilling to the water table is done with a simple disk drill, specially made for this purpose. A concentric hole is made in a circular disk, which is then sawn open and bent as shown in fig. 2.1.

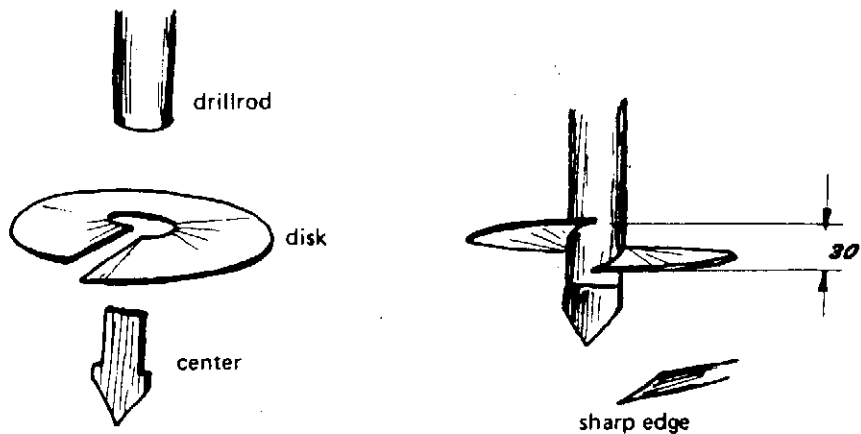

Fig. 2.1

The disk is welded or riveted to a pipe, which can be lengthened with connecting pieces if necessary.

A sharp edge is filed onto the cutting side of the disk (fig. 2.1.). It is advisable to guide the bore rod by means of a tripod so the hole is drilled as vertically as possible.

In order to rotate the drill rod a cross rod (lever) can be fixed to the drill rod by a clamp.

Two persons, one on each side, can operate the drill, while from time to time they have to pull the drill in order to remove the soil (fig. 2.2.) This will have to be done after a 15 or 20 cm progress of the drill.

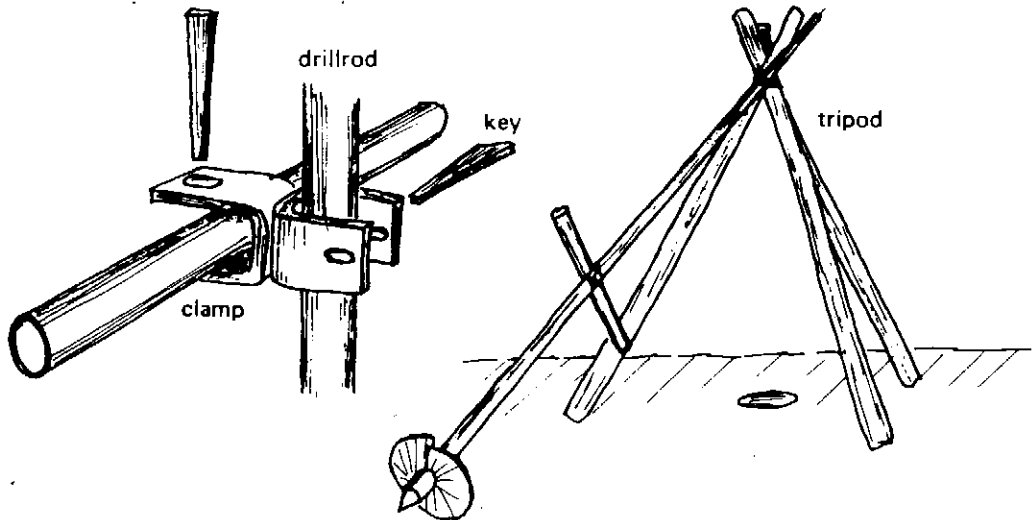

Fig. 2.2

Even in harder soil this type of drilling is suitable down to the ground water table. Once water-logged soil is reached, the walls of the hole will collapse, causing widening.

The drill also sticks and gets off-center. Therefore this drill cannot be used below the groundwater table. Usually a support pipe is put into the hole. The lower part of this pipe is perforated.

The perforation can be made by drilling holes in the pipe (lower part) or sawing cuts in the pipe or by using existing drain pipes. The last is the best.

As asbestos concrete pipe was available for the support of the pipe, there was a preference for drilling holes, (5 mm) over a length of 1,5 m to achieve the perforation.

In order to prevent filling with sand, the pipe was placed in the hole and the outside packed with fine gravel.

By drilling core out of the pipe until the gravel appeared, the pipe could be rammed down, thus the gravel went down together with the perforated section of the pipe. Drilling the core out of the pipe can be done by a pulsing ram, which consists of a pipe in which a butterfly valve is mounted; this is the so called pulsing ram (fig. 2.3.).



de schijfboor  
the disk-drill



de pulsboor  
the auger



het gebruik van de puls  
auger in operating



de zuiger  
the piston

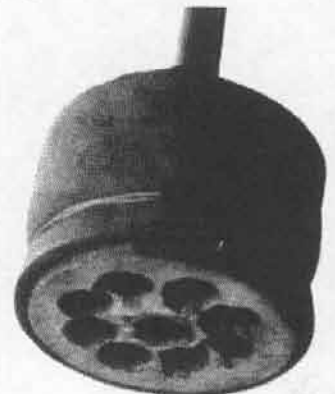

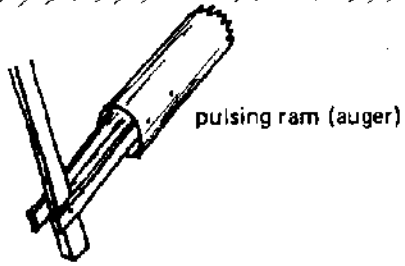
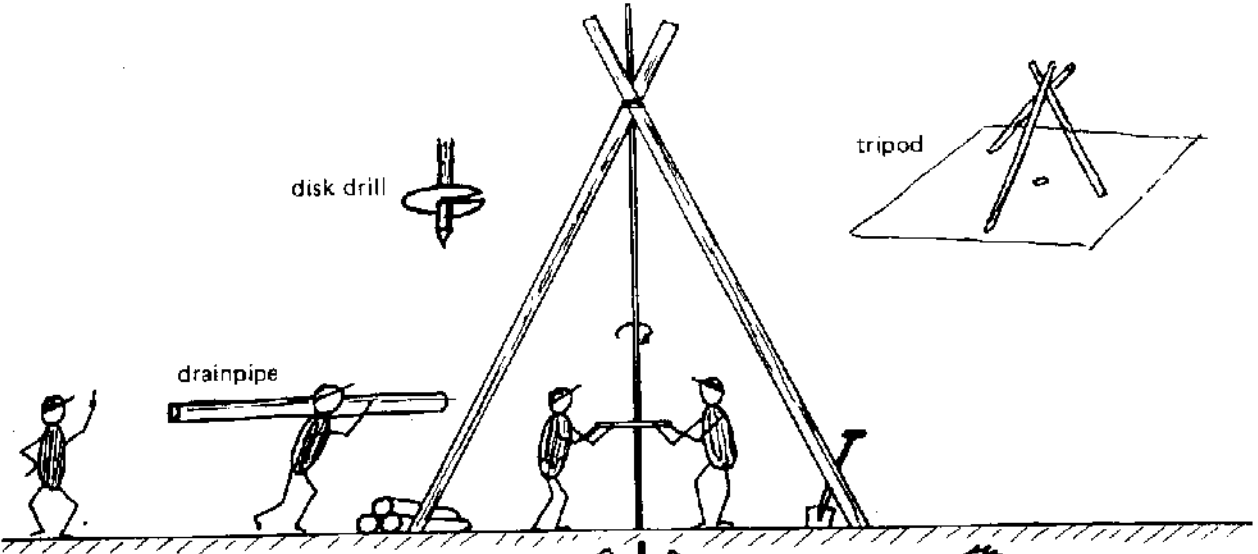
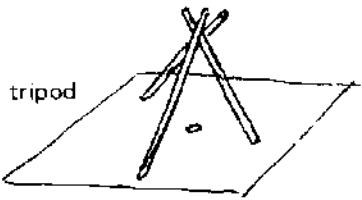

ram

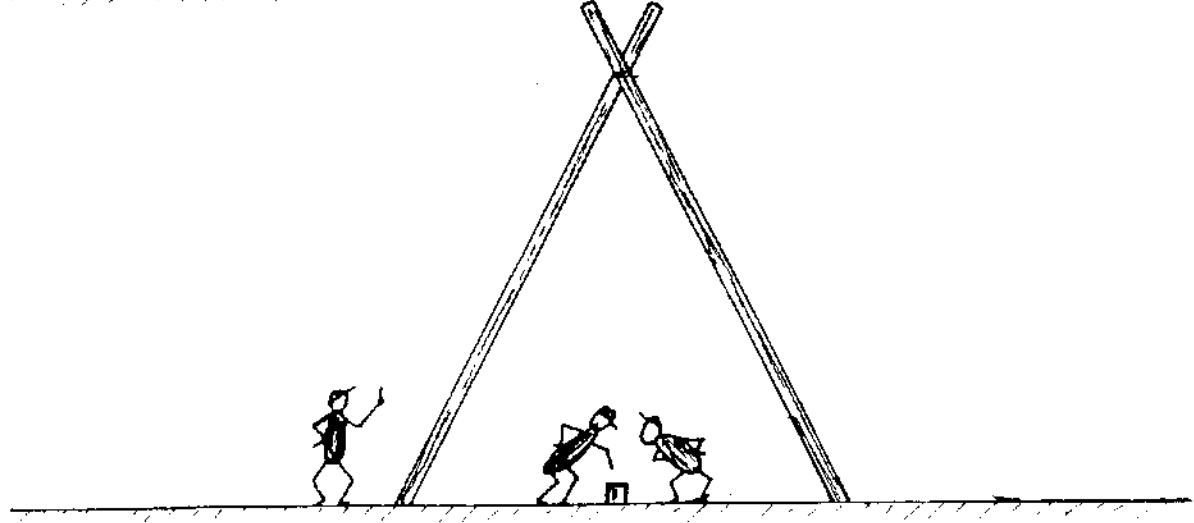
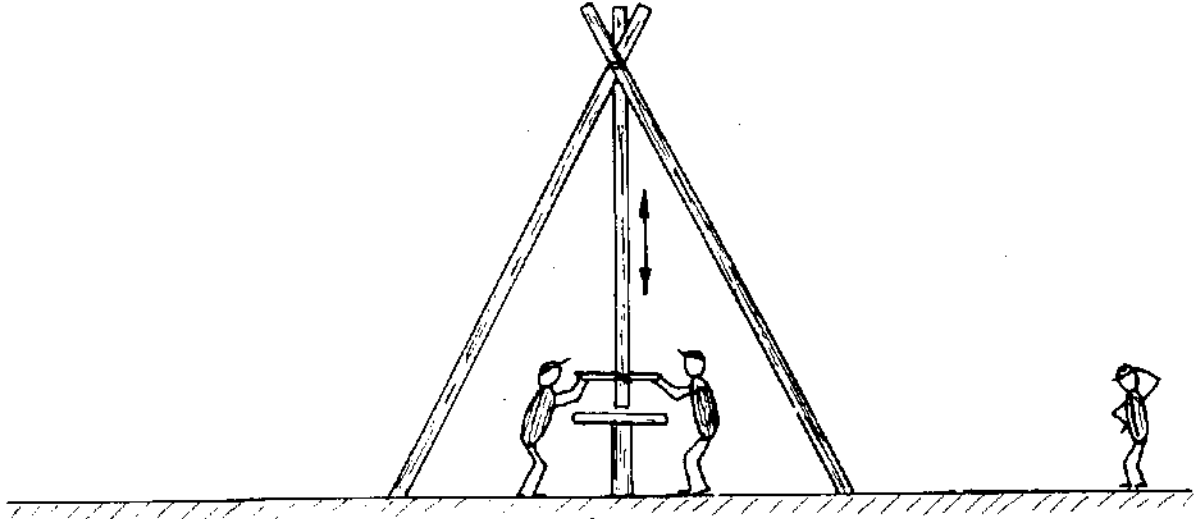
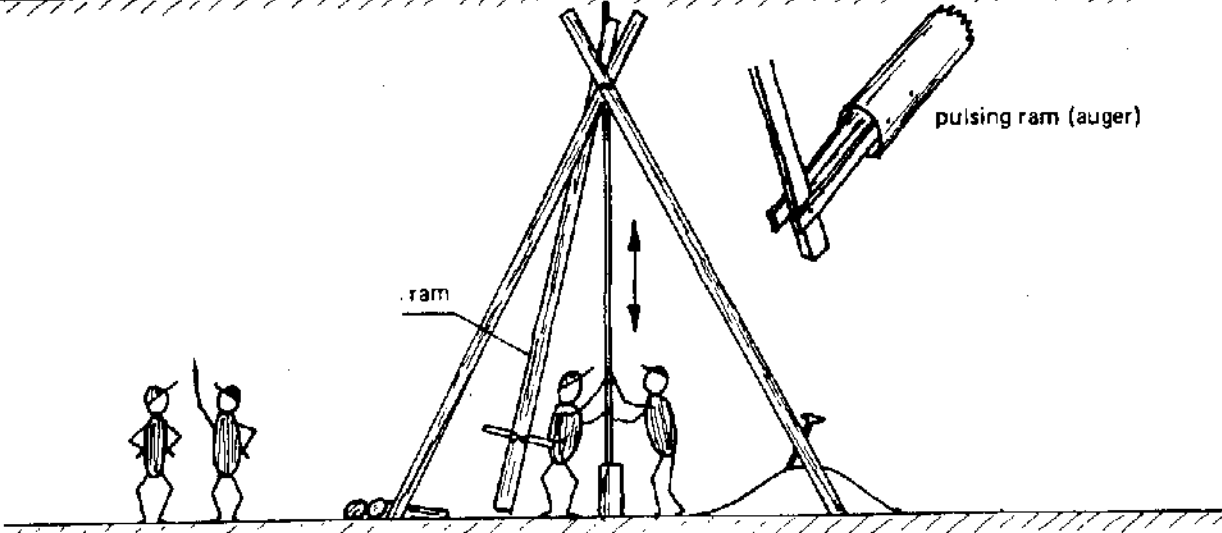

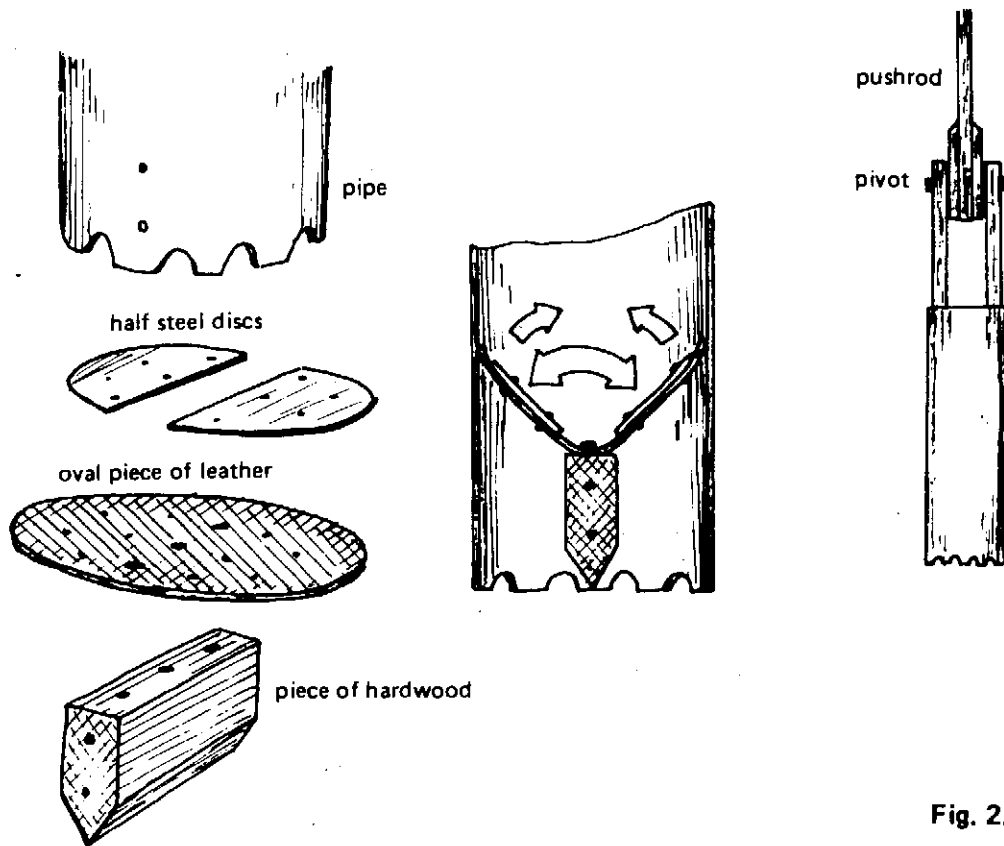

Fig. 2.3

The valve is an oval shaped piece of leather partly reinforced by half steel discs (2 mm steel).

These pieces are rivetted on the leather. The butterfly valve itself is mounted with wooden screws (or nails) on a piece of hard wood with a sharp edge.

The valve is mounted (clamp fitting) in the pipe and secured with screws. The pulsing ram will have to fit in the support pipe with a few centimeter space, and is moved up and down on the bottom of the hole by means of a drive rod.

The pulsing ram is taken out of the hole to be emptied from time to time. By making a pivot between the pulsing ram and the drive rod, the ram can be easily emptied. When the gravel also leaves the hole, this means that the hole under the support pipe is large enough to lower the entire support pipe including the gravel packing.

The tripod can be used as guiding to ram the support pipe every time appr. 10 cm. After this the action with the pulsing ram can be repeated. In case the support pipe has to be lengthened it is better not to use a pipe socket because this makes it difficult to supply new gravel around the support pipe.

To be sure the extended pipe is well centered it is advisable to place a mechanism with self guidance (fig. 2.4.).

In this way it will not obstruct the gravel from going down with the pipes and the pipes will remain well centered.

When the hole is deep enough the bottom is extra drilled and covered with gravel.



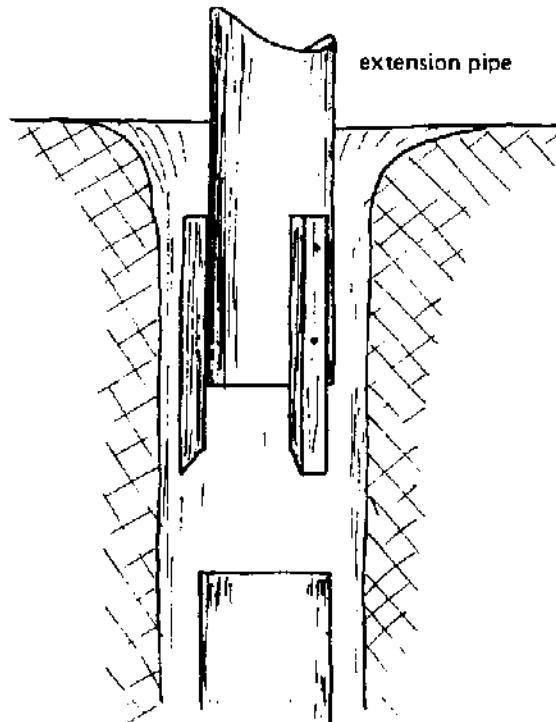

Fig. 2.4

## 2.2. The piston-pump

The complete piston-pump consists of a 5 m long pipe (in our case made of plastic) with an inner diameter of 125 mm.

The foot valve is located at 40 cm above the lower end.

The piston which is directly driven by the mill moves just above the foot valve. The lower end of the pipe has a coarse perforation and rests on the gravel (fig. 2.5.). The lower end of the pipe is stopped with a wooden disc or a plastic cover, fastened around the pipe with iron wire.

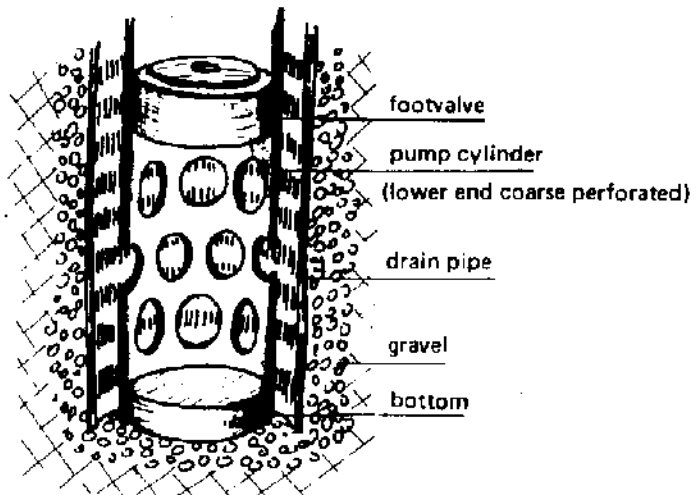

Fig. 2.5

The pump cylinder is centered with three wooden keys, where it comes out of the support pipe (= drainage pipe). The pump cylinder rises about one meter above the surface and is cut off at an angle. This is done to discharge the pumped water in the desired direction and to facilitate mounting of the gutter and of the piston. The gutter itself slopes slightly towards the storage tank and is founded with two beams driven into the soil as shown in fig. 2.6.

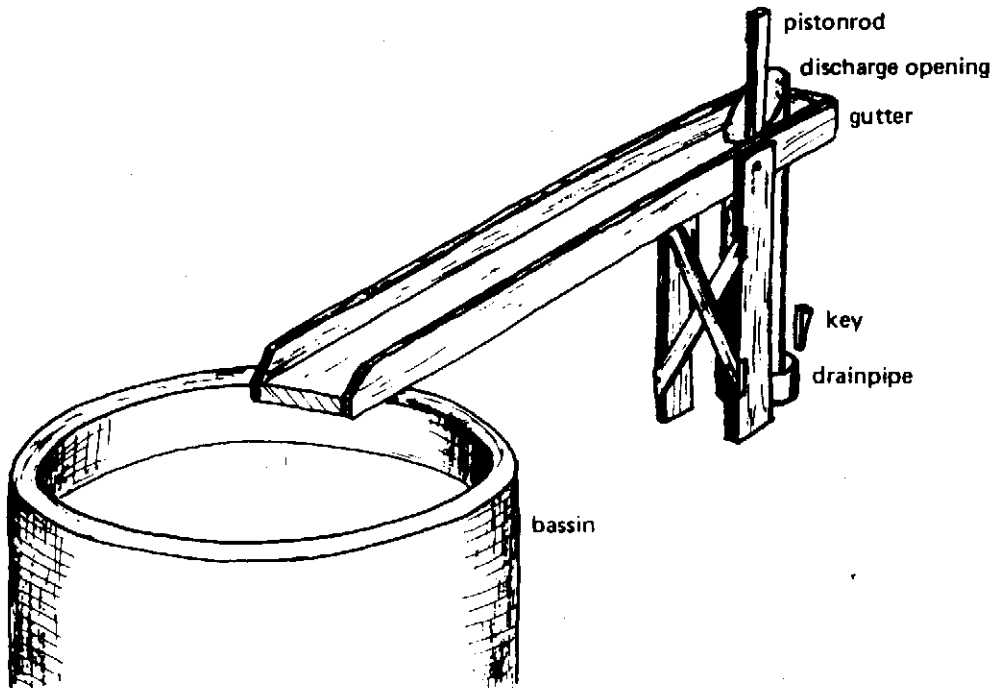

Fig. 2.6

### 2.3. The foot valve and the piston

As mentioned before these parts should be exactly circular shaped. For that purpose a special foot driven, wood-work lathe has been constructed. Because the piston acts not only as a plunger but also as a valve, the foot valve and the piston are manufactured more or less in the same way. The essential difference between the two is that the specific dimensions are derived from different diameters ( $D$  and  $D'$ ). A groove must be turned around the piston to secure the leather sealing.

The piston and the foot valve are made of wood; since in practice the dimensions appear to be large, it is necessary to compose these parts of more than one piece of wood, as shown in fig. 2.7.

The splitting in halves of the piston allows connection of the parts with the aid of a bolt/nut joint around the lower end of the wooden piston rod. The latter is planed in a round shape.

The bolt head and nut can be sunk down into the two diametric holes of the piston.

### Piston- and valve dimensions:

(using a 6-hole performance apply the ratio's placed between brackets)

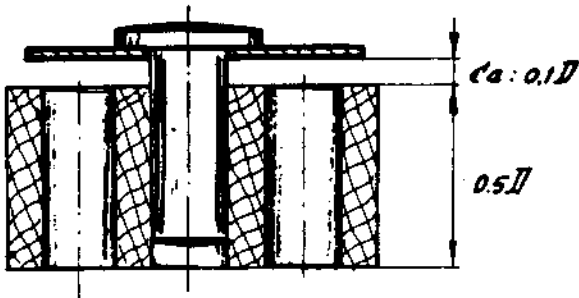
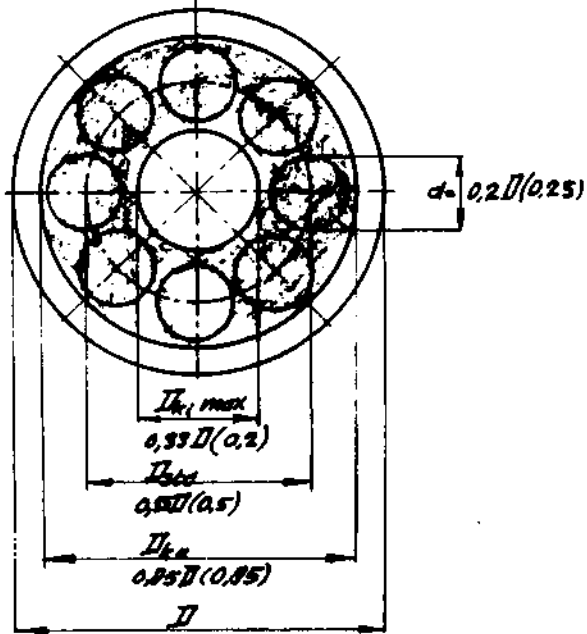

Valve: diameter  $D$  is the pumpcylinder-diameter

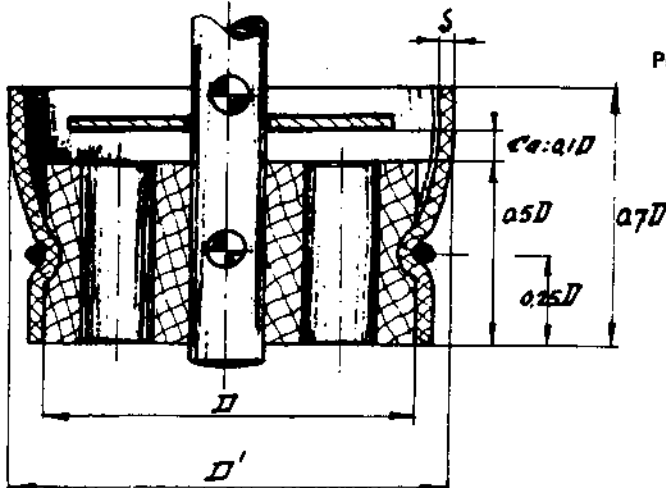

Piston: Measurements expressed in  $D$ , diameter of the wooden piston body.  
Pumpcylinder diam. =  $D + 2s + 5 \text{ mm}$   
 $s$  = thickness of leathersealing

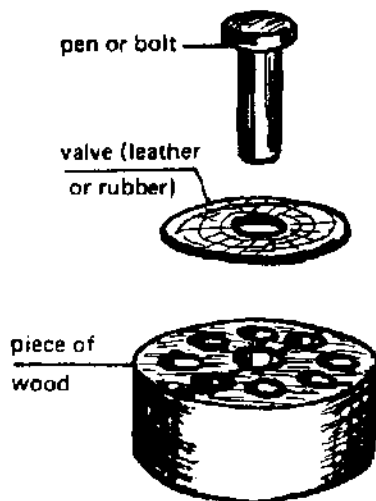
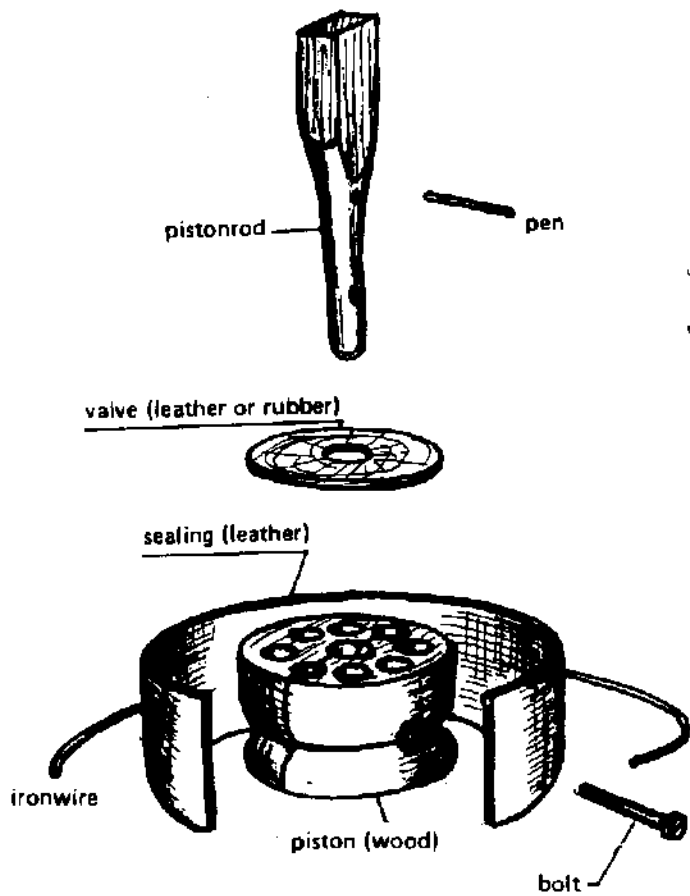
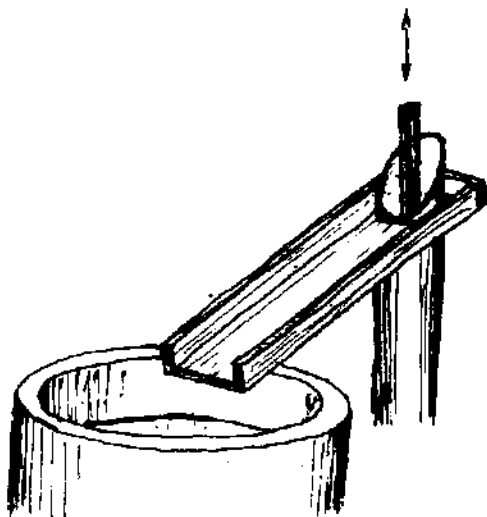

Mount the valve body in dry condition!

simple pistonpump

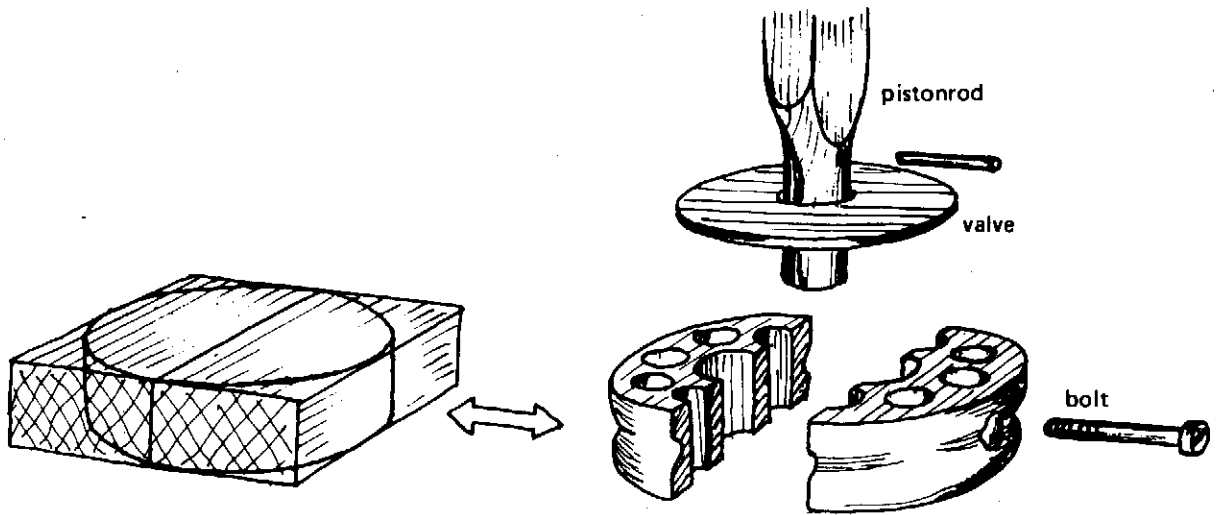

**Fig. 2.7**

The leather sealing has to fit very precisely around the circumference of the disc before installation. The ends of the leather sealing should overlap about 5 mm and be bevelled with a file or sand paper. The leather is put into water to make it more pliant and soft. The sealing is finally rolled onto the piston and roped in the groove with iron wire.

The halves of the foot valve are by preference glued together to facilitate further preparation.

After the leather valve is mounted on the disc with a bolt or a pin, the whole is put into the lower end of the pump cylinder with a clamp fitting.

Although wood will swell in water it is recommended to fasten the valve in the pump cylinder with screws.

Now the pump cylinder is ready to be mounted as mentioned in section 2.2.

### 3. THE WINDMILL

The windmill is built above the center of the bore hole and drives the plunger directly by means of a vertical wooden rod. The rotary movement of the windmill-shaft is converted into the required reciprocating motion by means of an adjustable crank.

The windwheel (rotor) consists of eight poles to which tri-angular sails are attached.

When the mill is out of use, the sails are simply wrapped around the rotor poles.

In order to be able to do this in a safe manner, a belt-brake is used which can keep the mill-shaft blocked in any position.

From the lower platform one person is able to operate the belt-brake and wrap or unroll the sails.

The second platform is situated at the top of the tower, from which most of the essential moving parts can be lubricated and inspected.

The wind vane, for keeping the mill into the wind, is fixed on the extending end of the mill head.

The centre of the mill-shaft is situated about 7 m above ground level, the rotor blades being six metres in diameter.

#### 3.1. Constructing the tower

The tower is assembled completely on the ground, impregnated with tar distillate and erected above the centre of the well.

The lower ends of the legs are placed in the pre-dug holes with foundation. After the position of the tower with regard to the well-hole has been checked with a plumb-bob and a water level, the legs are provided with impregnated braces and covered with mud.

For the construction of the tower four pine poles are used, approximately 7 metres long and varying in diameter from about 8 to 15 cm.

Also needed are 12 semi-round logs, each approximately 3 m long and 4 heavy wooden boards for the platform, a steel pipe, having an external diameter of 150 mm, a wall-thickness of 4 mm and a length of approximately 2 m.

Wood-screws (5<sup>u</sup>) and threaded studs (M10) are used for most of the construction parts.

After the poles have been cut to equal length, firstly the two tower-halves are assembled on a flat area (fig. 3.1.).

Then, the two halves are placed on top of each other, the lower end is provided with temporary diagonals and both sides are completed.

The four top-ends of the poles, thus far being held together by roping, are disconnected and the steel pipe is mounted as shown in fig. 3.2.

The ends of the poles, two by two, are pulled towards each other by threaded studs (M10) and nuts.

It is important to insert a couple of large washers, preferably slightly bent, between the nuts and the logs. Also, a small bearing surface should be rasped or planed on the inner side of the poles to prevent crushing or splitting of the wood when firmly clamping the pipe.

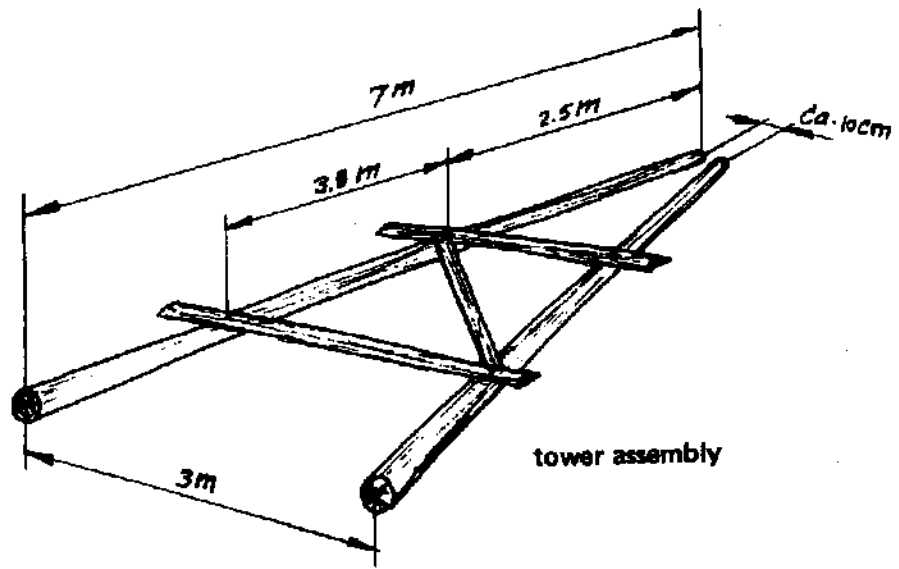

fixing the towerpipe

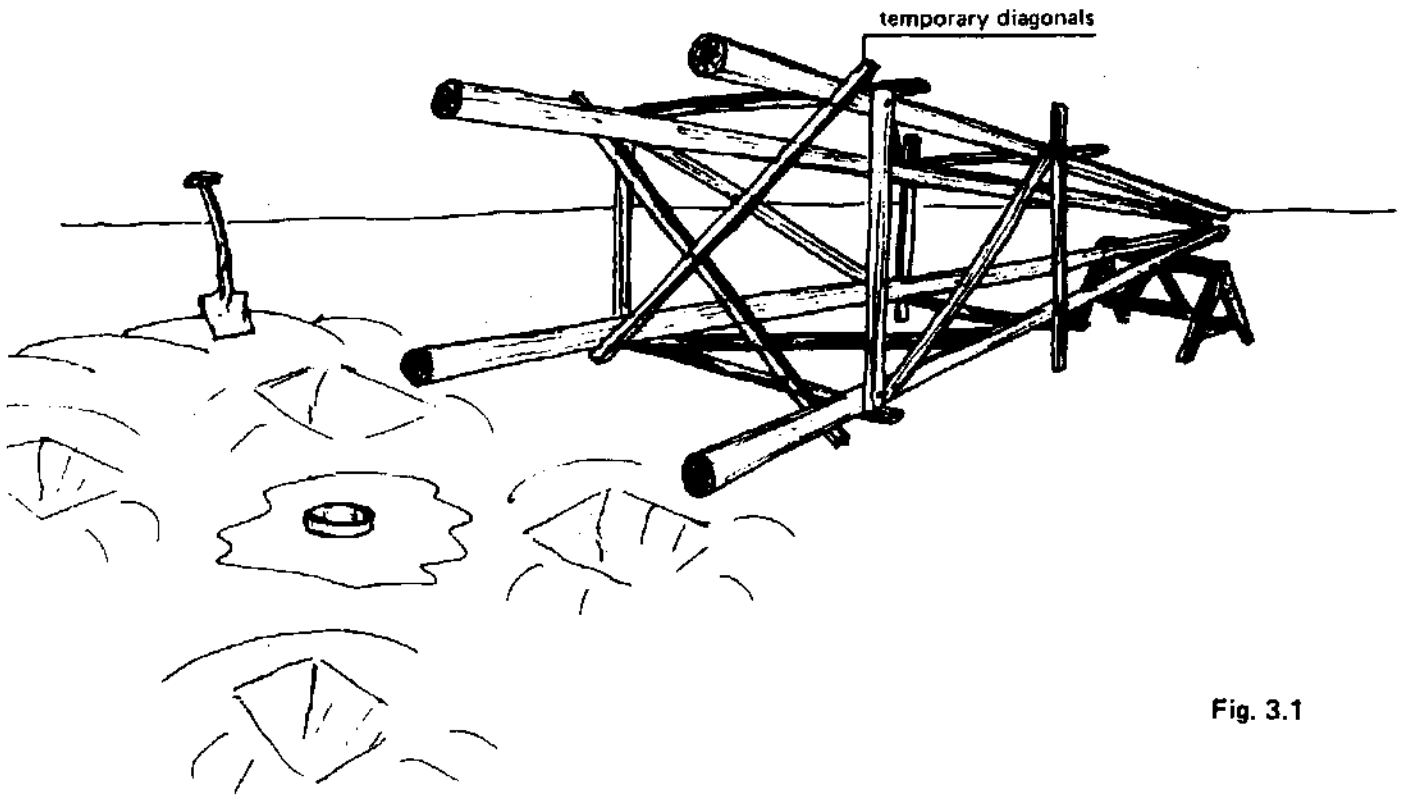

Fig. 3.1

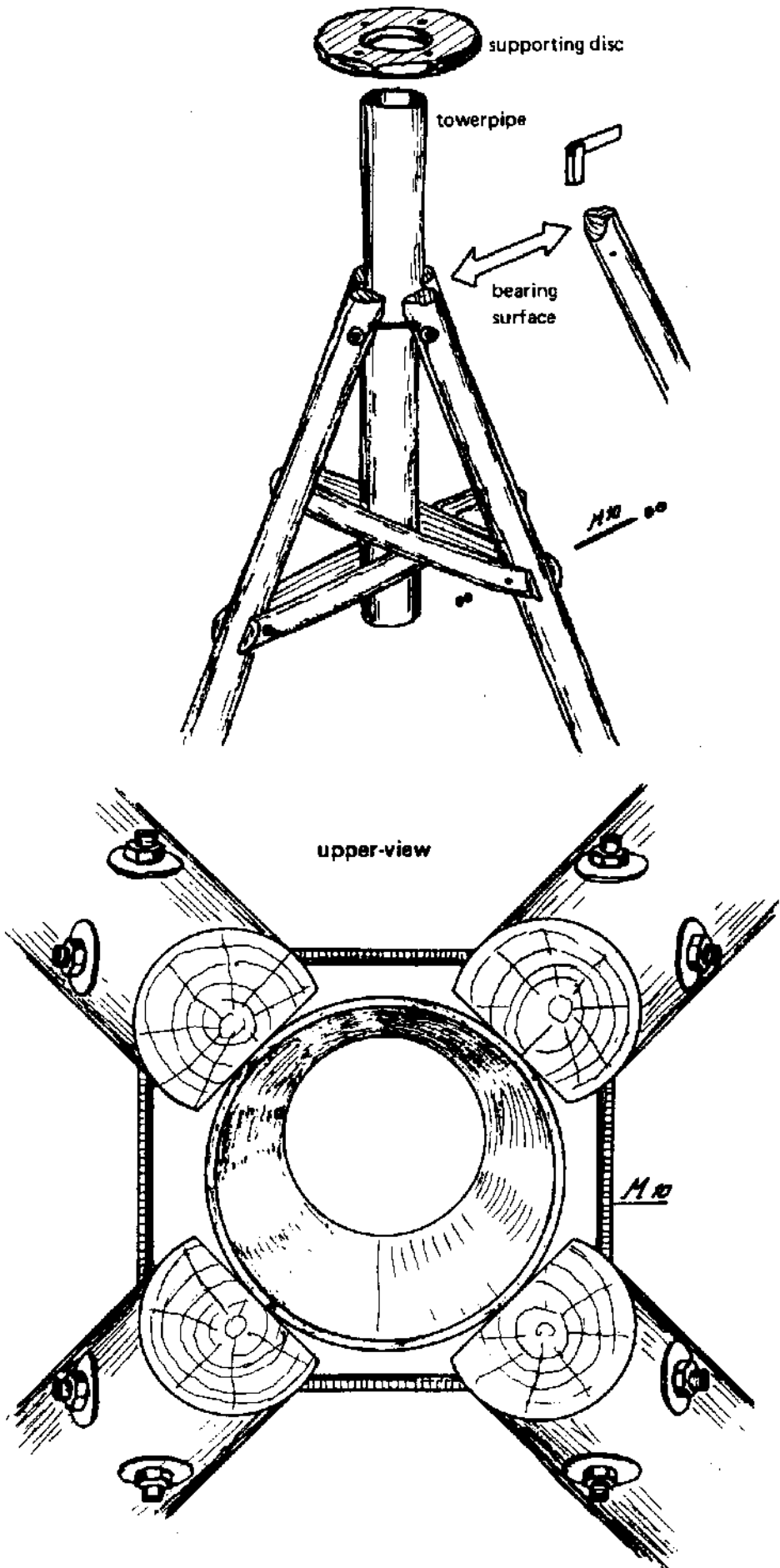
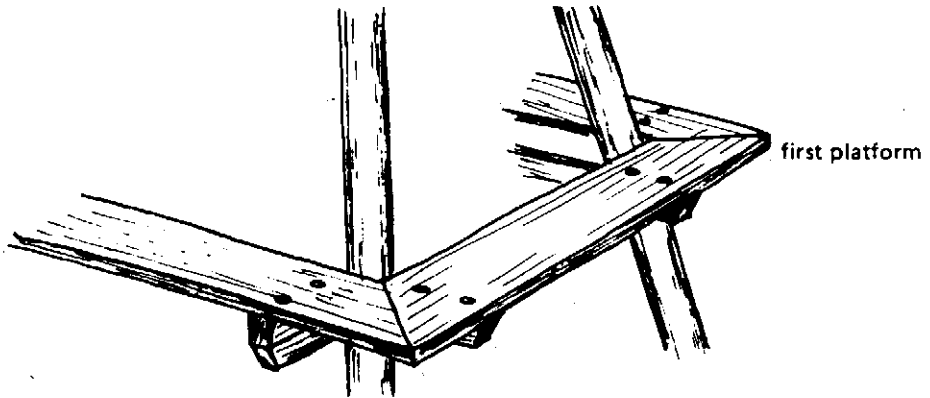

Fig. 3.2



A circular or octagonal wooden supporting disc (assembled from nailed and crossed boards) is mounted on top of the poles by means of 4 screw-bolts with countersink heads. This disc will carry the entire head of the windmill. When still in a horizontal position two platforms are fixed to the tower.

It is recommended to mount all boards of the lower platform carefully in one plane and also to countersink the heads of all mounting screws (fig. 3.3.). These measures are absolutely necessary to prevent unpleasant stumbling on the platform.



**Fig. 3.3**

To be able to reach this platform safely, a ladder is later placed on the inner side of the tower.

The second platform (at the upper end of the tower) only consists of two planks. This has been done in order to be able to climb safely onto this platform by means of the steps attached to the tower-legs (fig. 3.4.). The lowest steps may serve as a handrail for the lower platform.

### 3.2. The foundation, the erection of the tower and the alignment

Four holes (60 cm x 60 cm x 90 cm deep) for the legs of the tower, are dug around the existing or newly drilled well.

Then, each hole is provided with a floor of stones on which the tower legs will rest, and if necessary can be shifted a little.

The top of the floors are levelled, in order to make sure they are in one horizontal plane. This is checked with the aid of an accessory specially made for this purpose and of a water level (fig. 3.5.).

To erect the tower, the following procedure is suggested.

3 to 4 persons push up the top of the tower with the help of a ladder. Two more persons support the tower with wooden beams, each time the ladder is removed from the top of the tower, to push it up again with a higher step of the ladder.

To prevent the pushing step of the ladder to slide away along the pipe in the tower, this pushing step is roped to some part of the tower.

When the tower is pushed up as far as possible with the ladder, a long drag line is attached around the pipe. Three or more persons now pull the dragline, while at least three persons continue to push with the ladder.

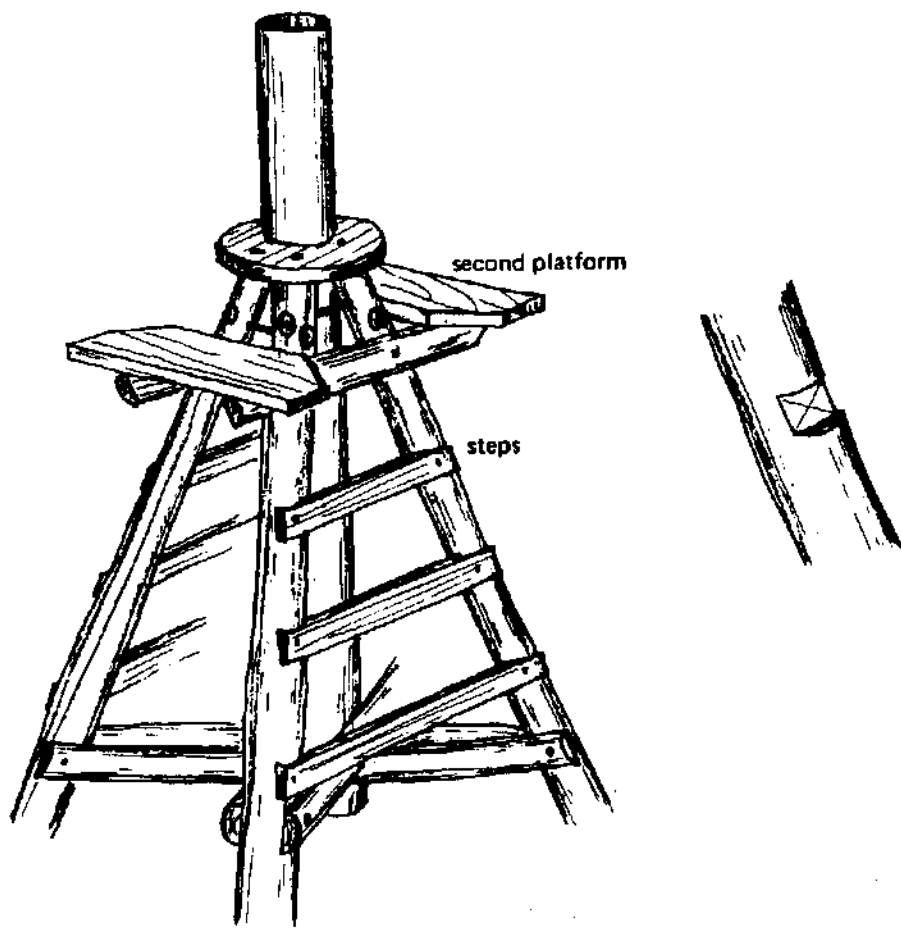

Fig. 3.4

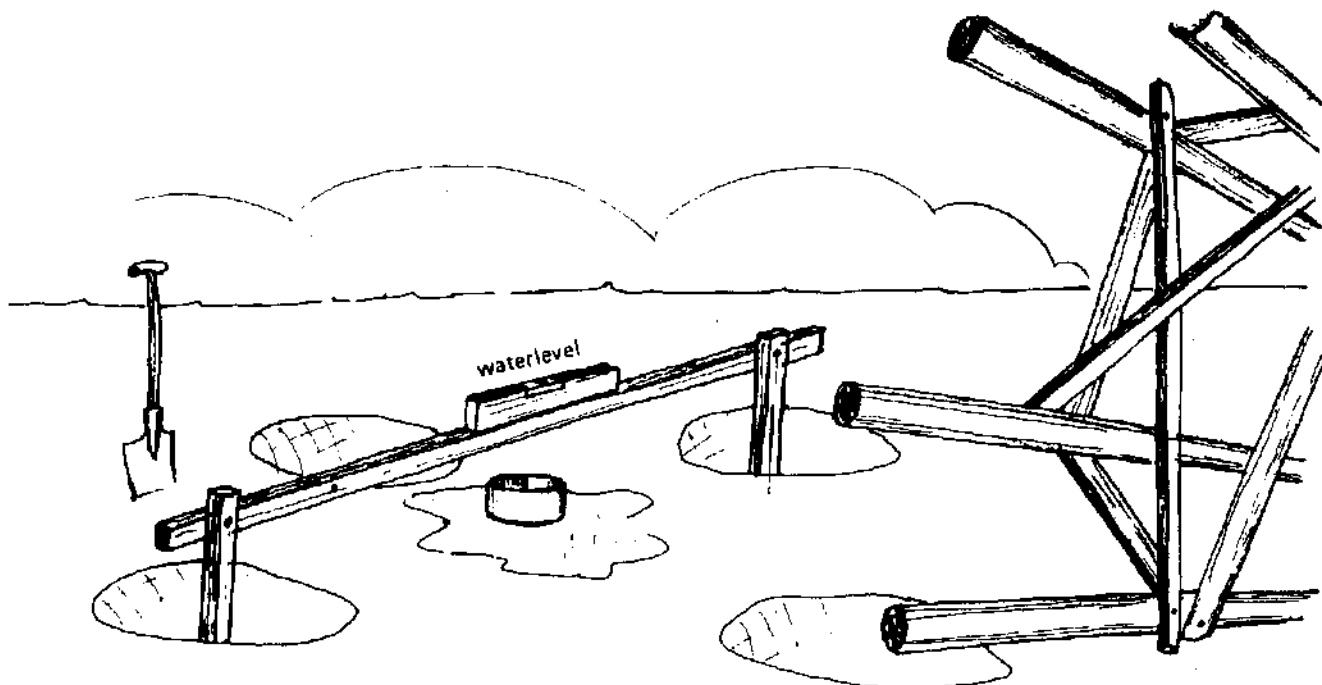

Fig. 3.5

To prevent the tower from overshooting, two persons keep control with a second dragline on the opposite side of the first.

Fig. 3.6. illustrates this action.

A water level is used to check whether the pipe in the tower is in an exact vertical position.

Corrections can be made by placing keel blocks of wood under the legs. With a plumb-bob the correct position of the centre of the pipe over the centre of the well is checked.

After the alignment the legs are provided with braces (fig. 3.7.) and impregnated with tar.

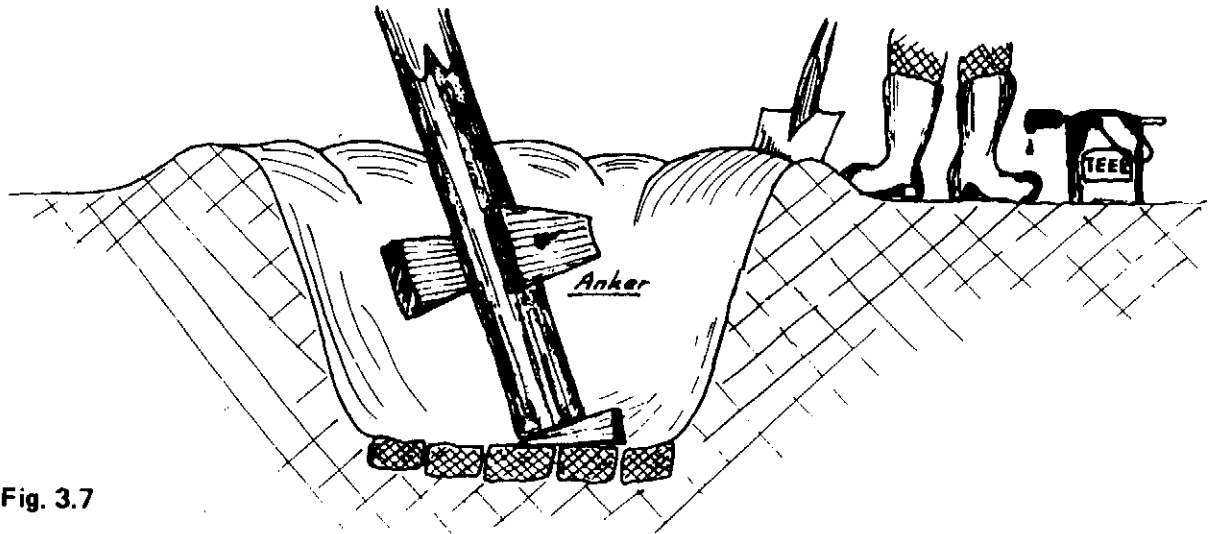

Fig. 3.7

Then the holes are filled with a mixture of sand and water. The temporary diagonals in the lower part of the tower may now be removed.

Now, the tower can be completed. First of all, the ladder is placed on the inner side of the tower, to be able to reach the first platform safely.

The lower end of the ladder is dug into the ground.

While the legs of the ladder reach first up to the first platform and are firmly nailed to it.

If the ladder is self-made we preferably start from knot-free legs, approximately 4 m long.

The steps (roughly cut laths) are partly sunk down into the legs and nailed into place.

For easy climbing the tread of the steps should be about 30 to 35 cm and the ladder should be at least 35 cm wide. (mind the available space between the inner edge of the platform and the pump shaft).

### 3.3. The head construction

Figure 3.7a shows the construction-drawing of the frame with dimensions of the whole head construction including the tail-vane.

Figure 3.8. shows a blown-up view of all parts of the head.

The wooden parts are, like those of the tower, nearly all connected to each other by means of wood screws.

Fig. 3.6 erecting the tower

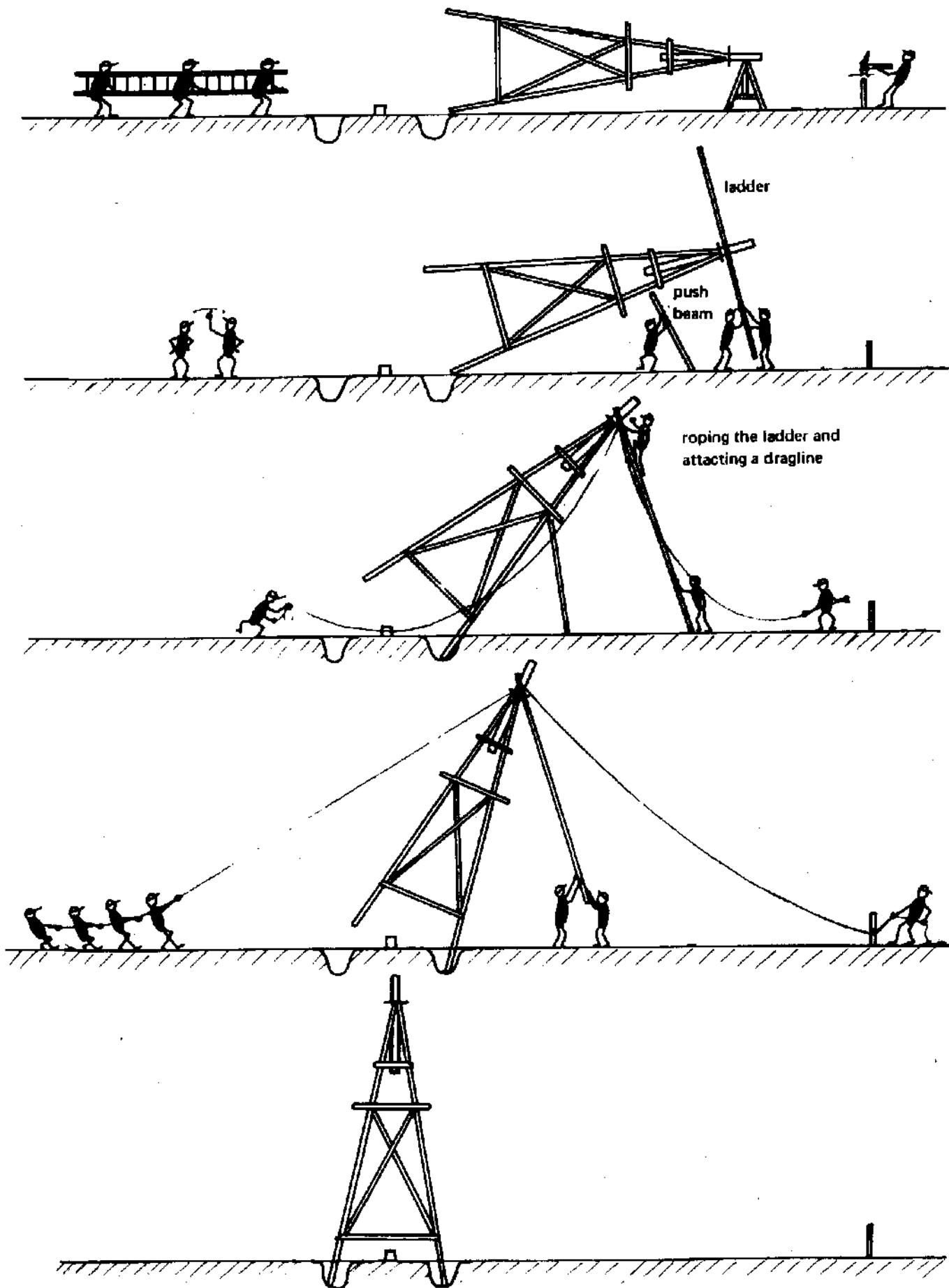

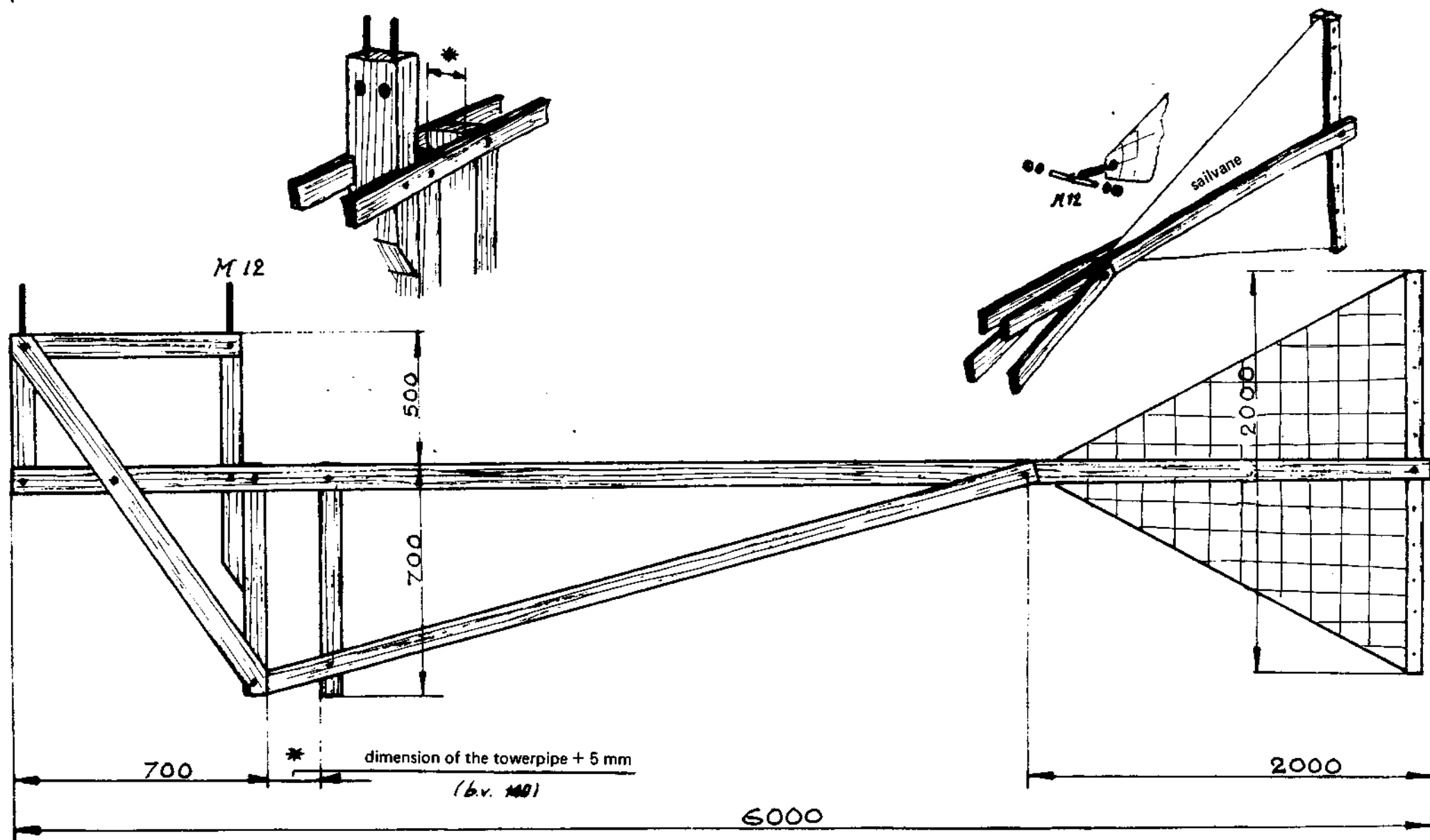
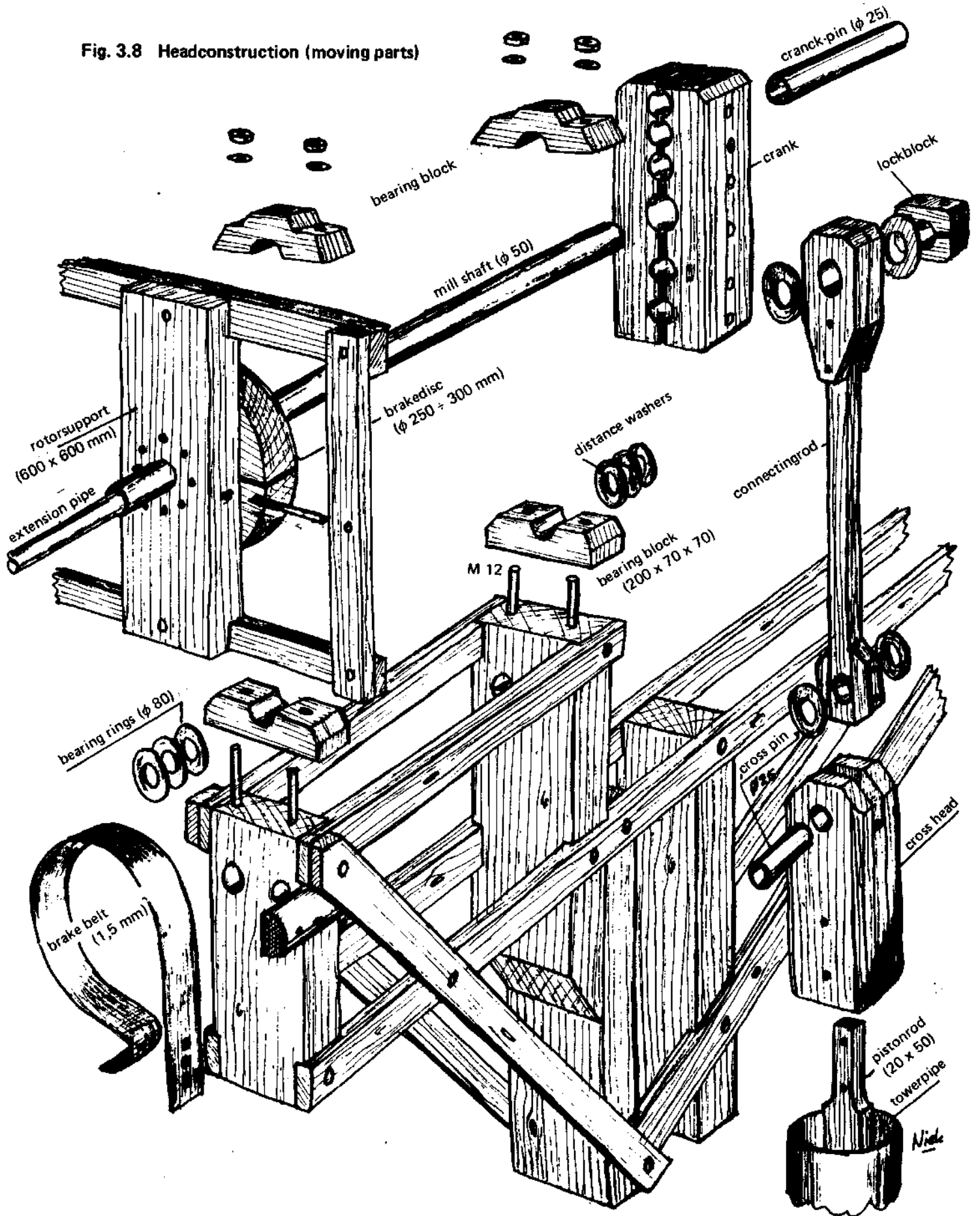
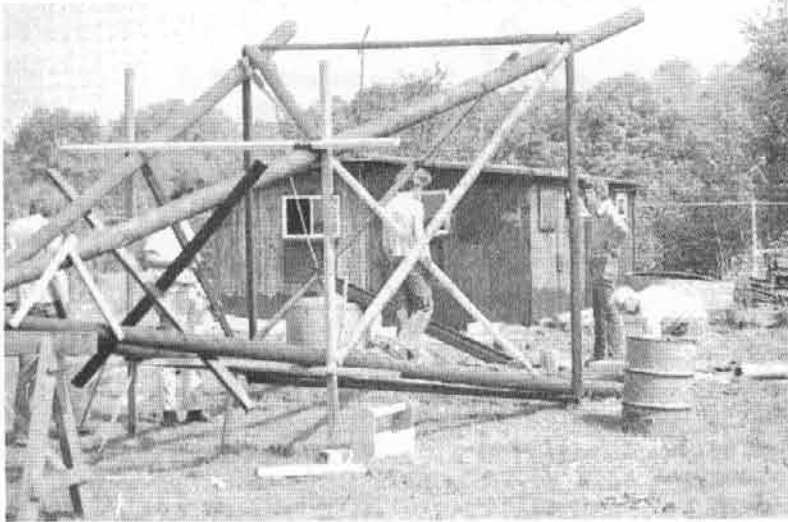
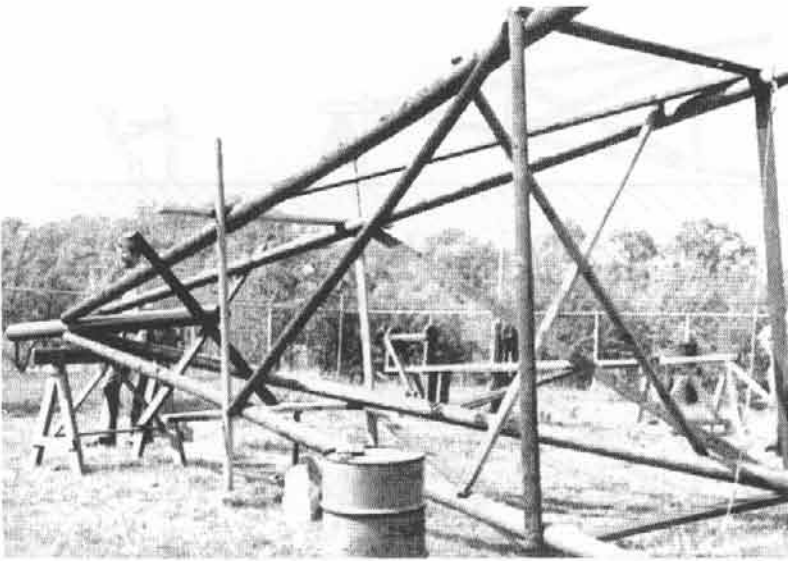

Fig. 3.7a

Fig. 3.8 Headconstruction (moving parts)





de toren in opbouw  
building the tower

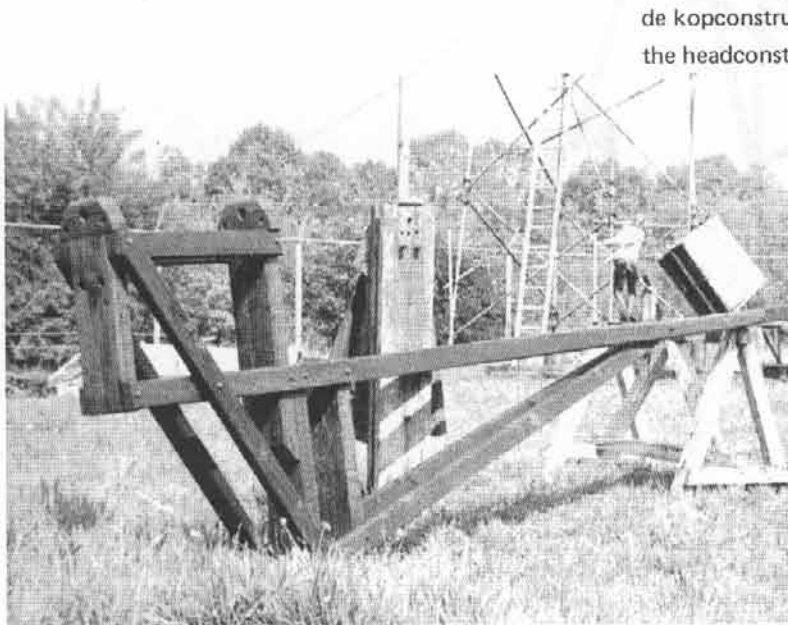

de kopconstructie  
the headconstruction

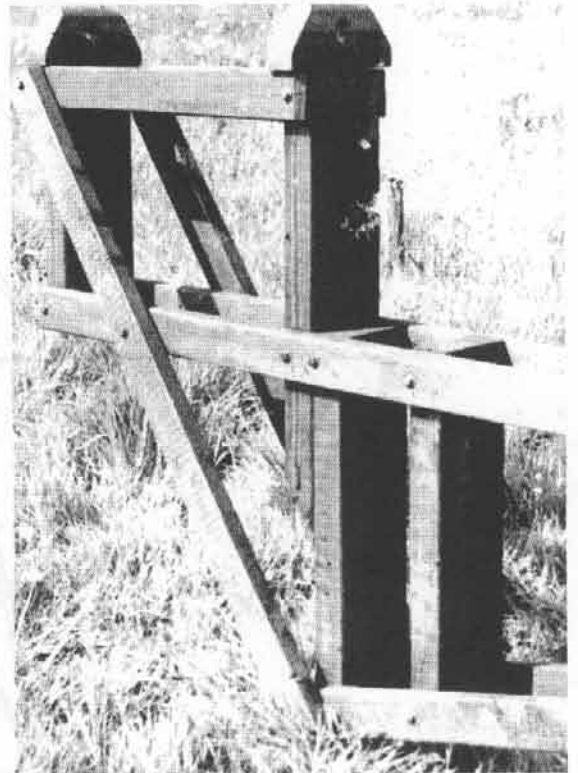

Tightening-constructions, like those of the crank-blocks and the bearing-blocks are effectuated by means of threaded studs (M12). The frame consists of a number of vertical timber beams connected by horizontal and slanting beams.

In this way a lattice construction is made, which is very rigid. The two triangular extension parts keep the vane clamped and in this way a light and strong tail is realised.

The two vertical beams at the rear together with the horizontal beams are placed around the tube which is part of the tower.

Because of the swelling of the wood, sphering and hollowing, the tube is given a margin of about 5 mm when the wood is dry.

The effect of the sphering and hollowing of the vertical beams can be compensated as shown in fig. 3.9.

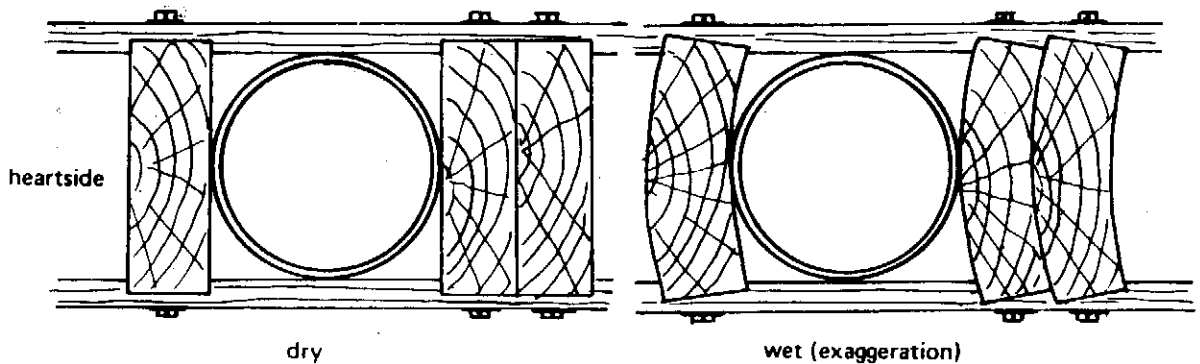

Fig. 3.9

On the ends of the two vertical beams at the front side the bearing-blocks are fixed by means of threaded studs M12.

Fig. 3.10. shows the anchorage of the thread-ends in the beams.

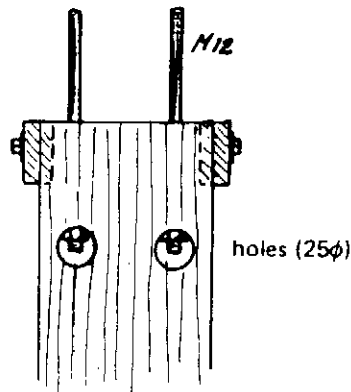

Fig. 3.10



### 3.4. The moving parts

The bearing-blocks consist of two parts and should be made of hard timber.

In order to be sure that the two parts fit together well, the holes should be bored while the upper and lower part are clamped together tightly.

A little hole in the upper part of the bearing-block makes it possible to oil or grease the bearings.

The crank also consists of two parts.

Both parts are clamped together tightly and after that the holes are bored as shown in fig. 3.11.

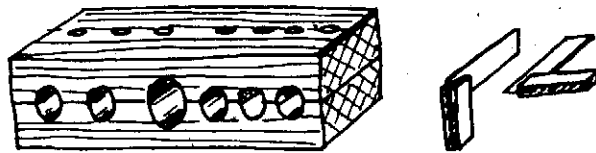

Fig. 3.11

After drilling of the holes, a thin layer is planed off from the inside of the two parts.

This is done to make the clamping of the mill-shaft and crank pin possible.

The construction of the crank in this way makes it possible to adjust the length of the piston-stroke in a simple way.

The length of the connecting rod is chosen in such a way that it just does not touch the rim of the tower-tube when the crank is in its horizontal ultimate position. In order to achieve this, it is recommended to make the connecting rod as slender as possible.

This means that the ends of the connecting rod should be thickened, which can be done as shown in fig. 3.12.

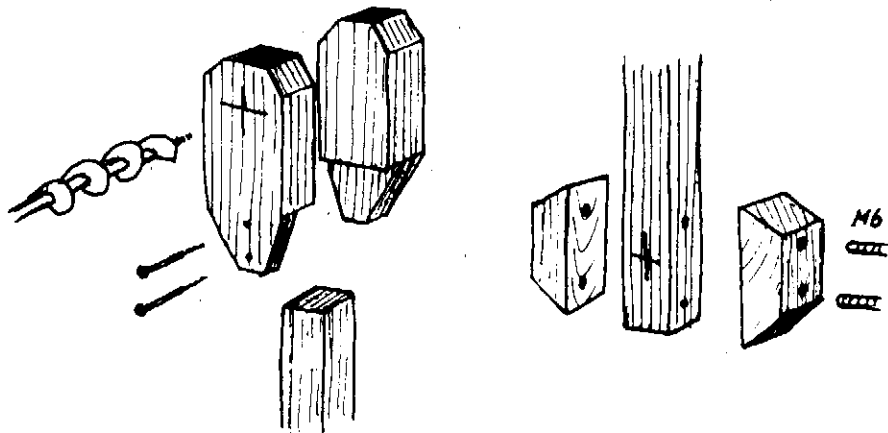

Fig. 3.12

The upper end of the rod should preferably be made of hard wood. The crank-pin has to be able to turn in it with a play of about 1 mm. For the supply of oil or grease, a little hole is bored again and preferably in such a way that the supply comes out under the pin (fig. 3.13.).

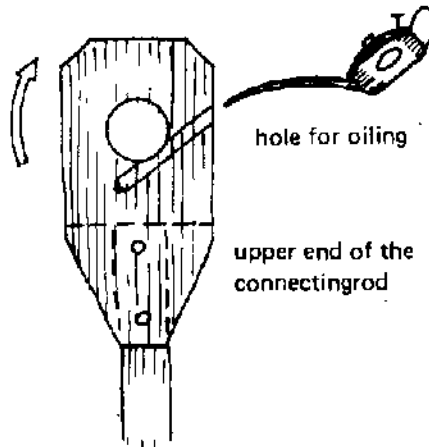

Fig. 3.13

The cross-pin is clamped in the lower end of the connecting rod. The latter makes a swinging motion in the cross-head.

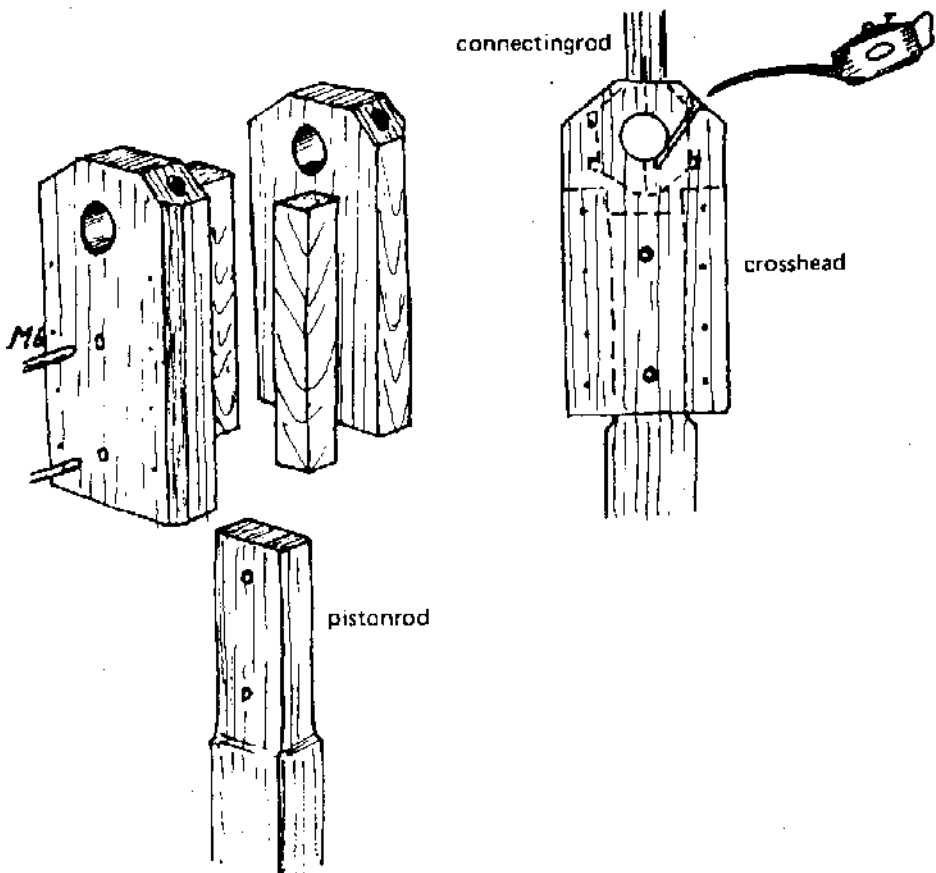
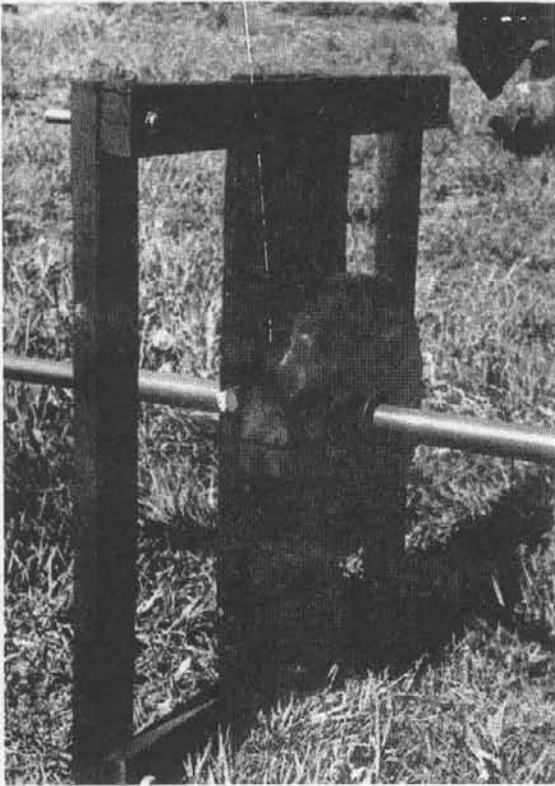

Fig. 3.14



het wiekenraam  
the wingframe



de deelbare kruk  
two-part crank

de molenas met wiekenraam, kruk, drijfstang en leislof  
the millshaft, wingframe, cranck, connecting-rod and crosshead

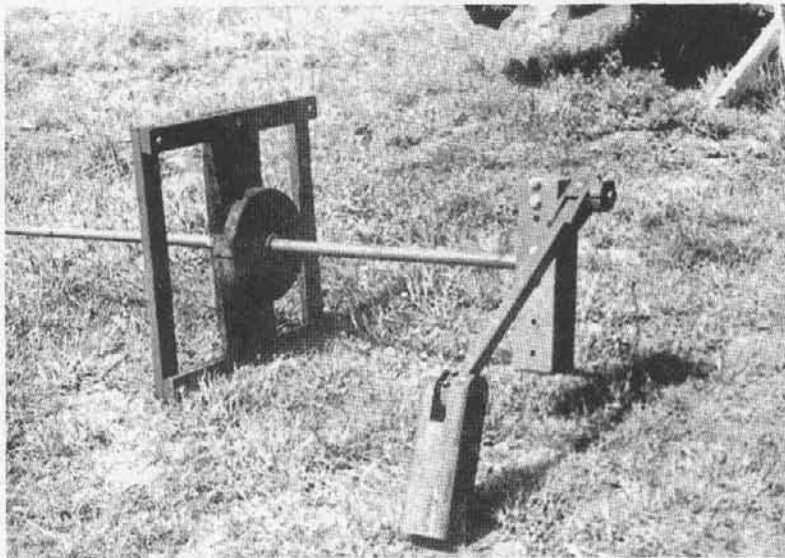

The holes for oiling or greasing in both shields composing the cross-head should be bored in the same way as those in the upper end of the connecting rod.

The shields are planed oblique to make the cross-head fit in the tower-tube.

In case the inside of the tower-tube is rough (for instance because of corrosion or the presence of a joint) it is recommended to cover the cross-head with wearing-plates as shown.

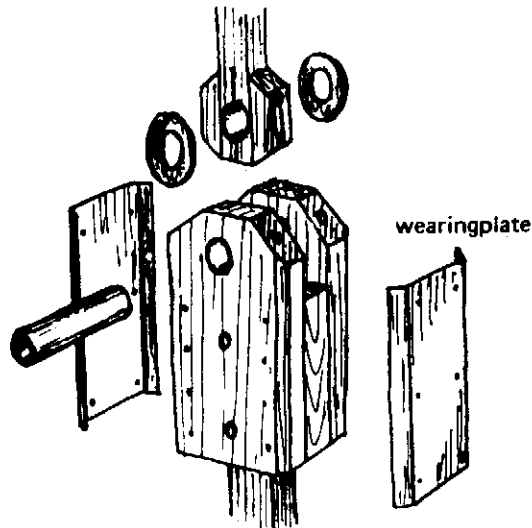

Fig. 3.15

In general the combination of two wooden treads should be avoided, in as far as these treads move continually with regard to each other. Therefore washers of sheet-iron or tinned plate are always placed between these treads (see fig. 3.8. and 3.15.: between crank-connecting rod and block; between shield-connecting rod and shield).

The number of pivot-rings between the brake disc and the bearing-block at the front side should at least be three.

In this way the wear and tear will take place on the washers and not on the wooden parts.

To make sure that the washers next to the wooden parts do not move with regard to them, they are placed with their hollow side toward the wood. The metal treads which move with regard to each other should preferably have a different metal structure to prevent fretting.

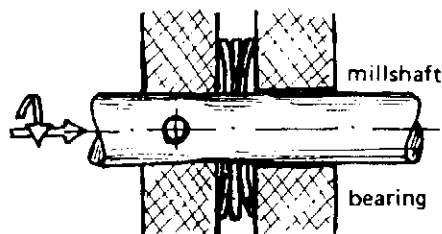

Fig. 3.16

The washer in the middle could be made of bronze or brass, while the other two could be made of sheet-iron.  
Of course the bearing property is improved by greasing regularly.

### 3.5. Brake construction and control

As mentioned above, the presence of a brake is indispensable for the safety of the operator and for the protection of the mill itself. For this type the so called brake belt has been chosen, working on the following principle:

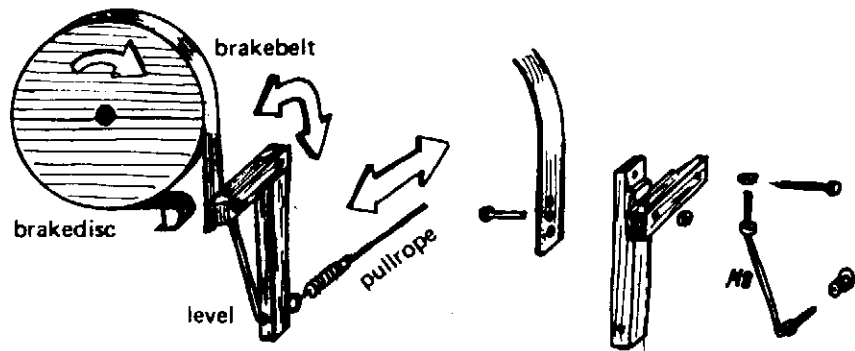

Fig. 3.17

The brake belt encloses three quarters of the brake disc. Theoretically the brake moment can be very high, depending on the tension of the pull rope. Of course, the maximum occurring brake moment must be limited to prevent burst of e.g. the brake belt or its fastening.

Figure 3.18. shows how this can be achieved by inserting a pull string in the pull rope. The pull rope is operated from the first platform by means of a handle and a noose shaped control rope.

The advantage of this construction is that during unrolling and rolling up of the sails the mill can be stopped in the wind. In this way operating by one man is possible and safe.

At loosening off the brake the brake lever must fall back under the influence of a push or pull spring, so that the steel brake belt comes completely free from the brake disk. It may happen that, by its own weight, the brake belt stays tightened to the upper side. This is caused by the repeatedly tightening and loosening of the brake belt and of course this can be avoided by supporting the brake belt at several places (fig. 3.19.).

Eventually such a support may consist of a lath, nailed to the head construction.

Readjusting the brake after wear and tear of the brake disk can be done simply by drilling several (8 mm) holes at the end of the brake belt. See fig. 3.20.

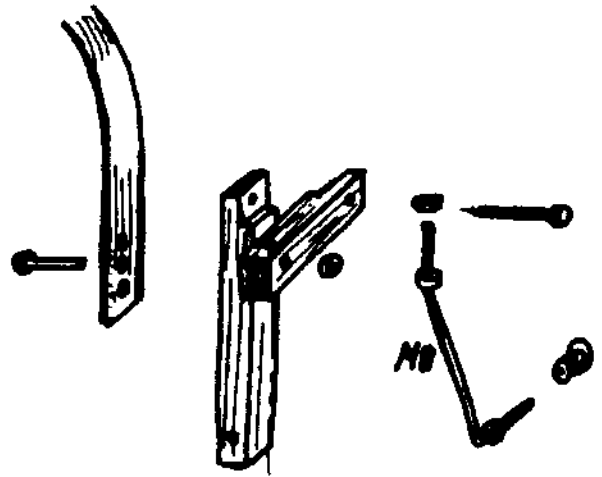
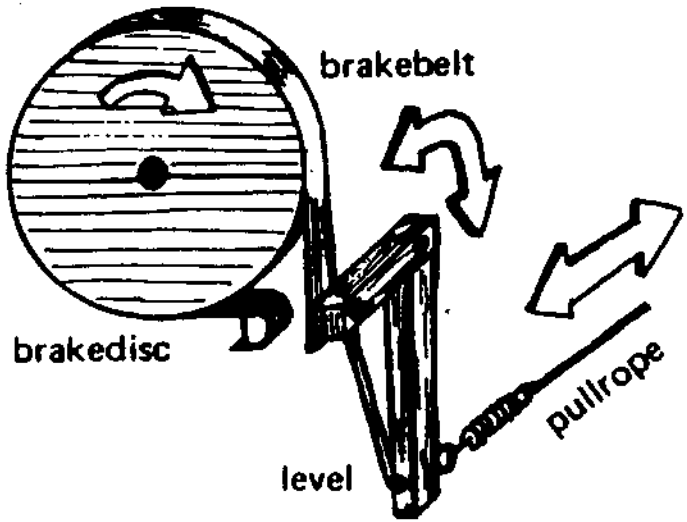

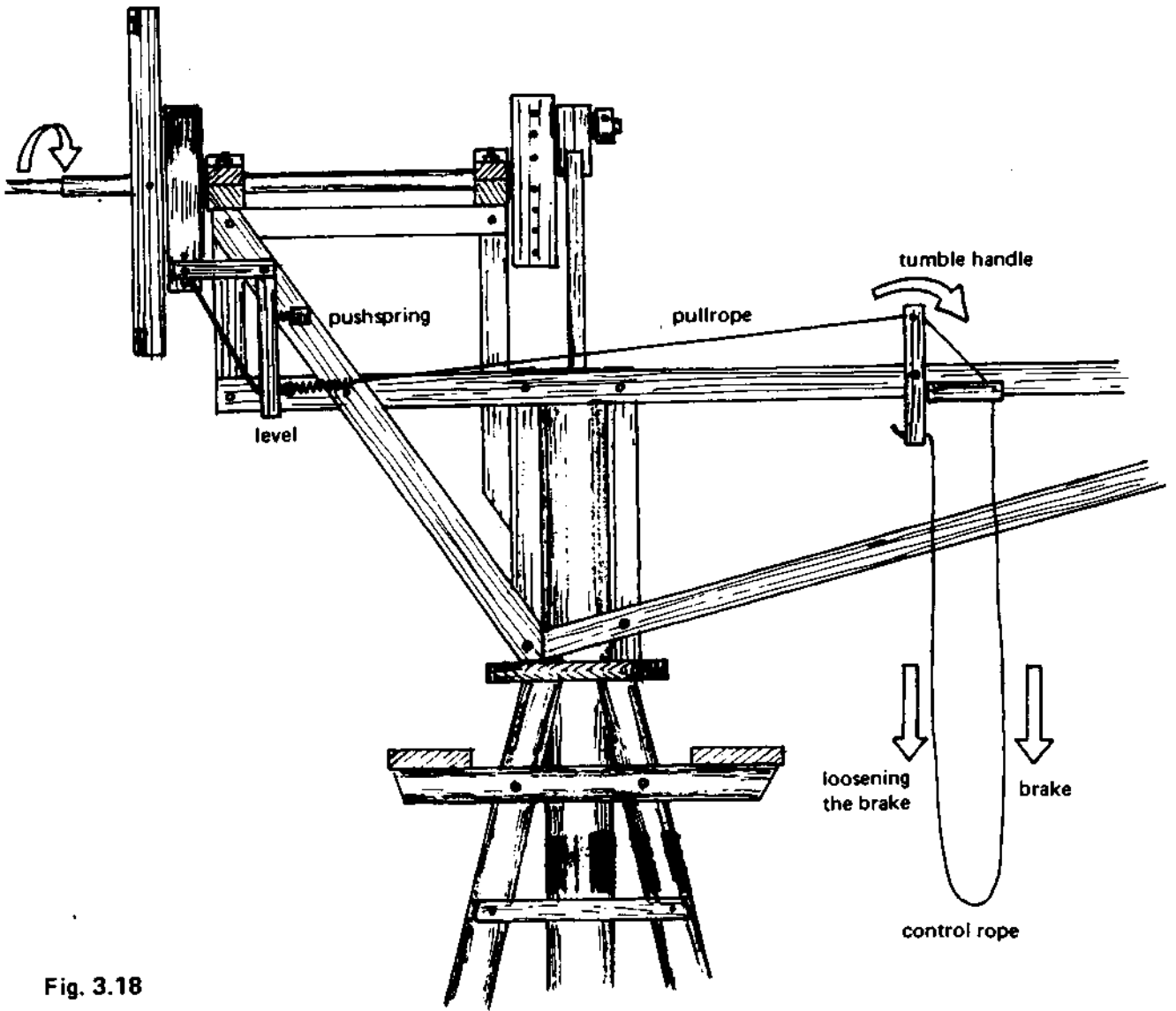

Fig. 3.18

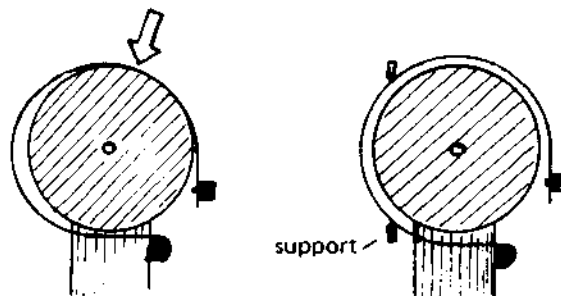

Fig. 3.19

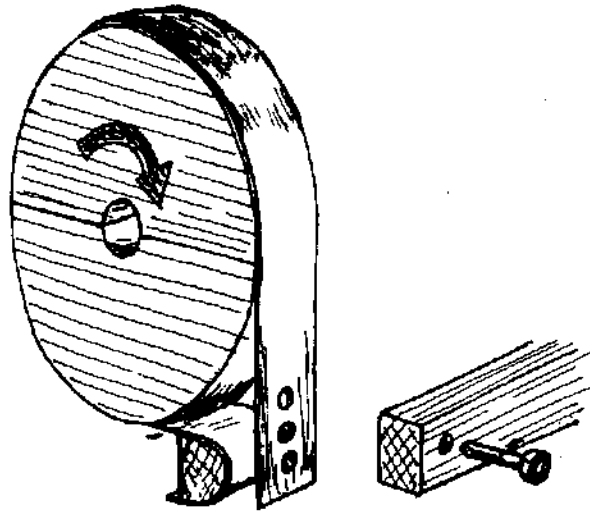

Fig. 3.20

Among other things for the purpose of replacement the brake disk is designed in two parts. Both halves are fixed to the mill axis by means of two M12 threaded studs, but one must realise that it is difficult to brake the axis directly, therefore it is sensible to apply a tightened fastening between the brake disk and the hub of the rotor. Figure 3.21. shows a very sound possibility.

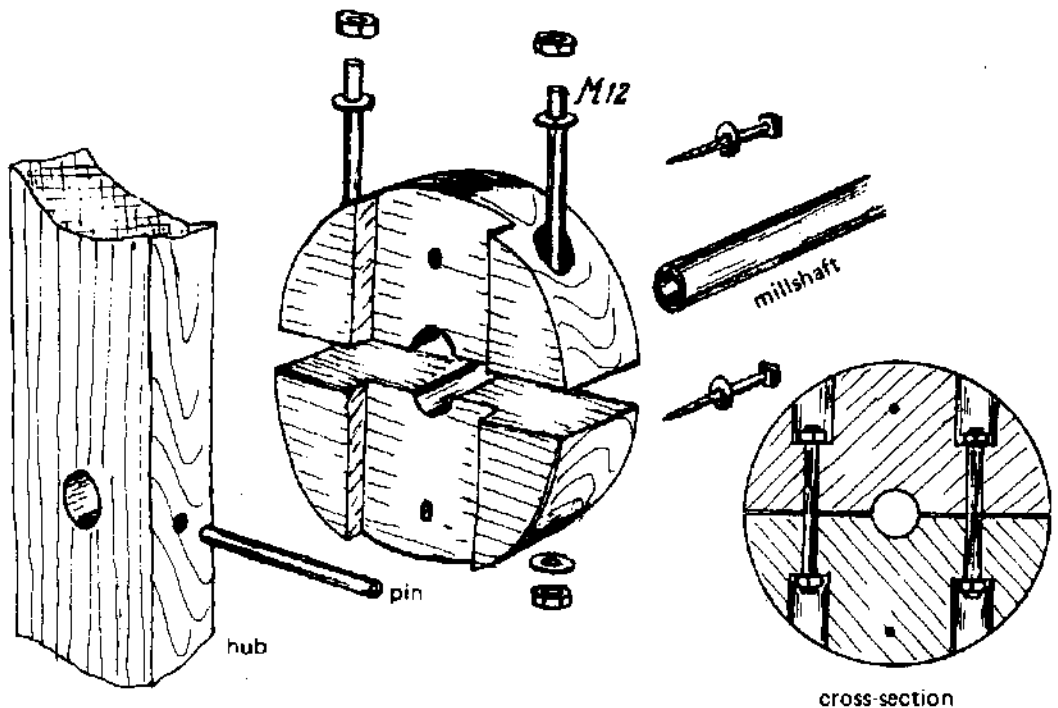
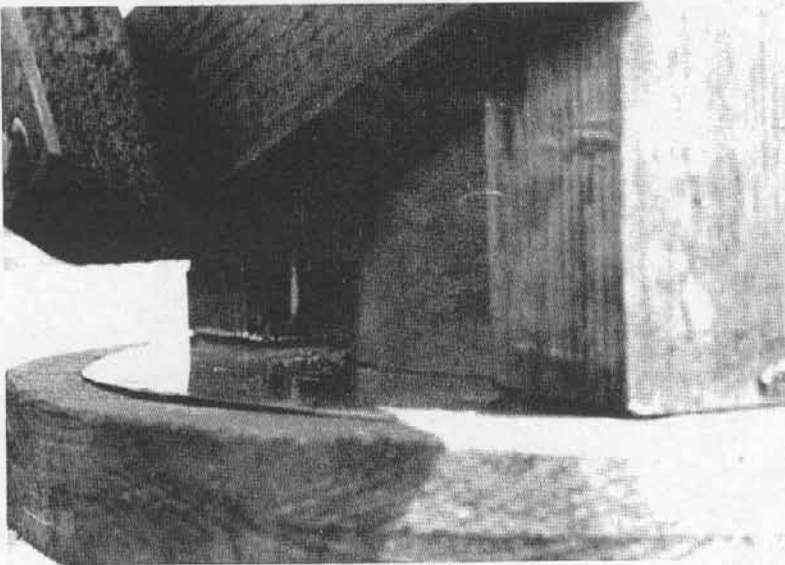
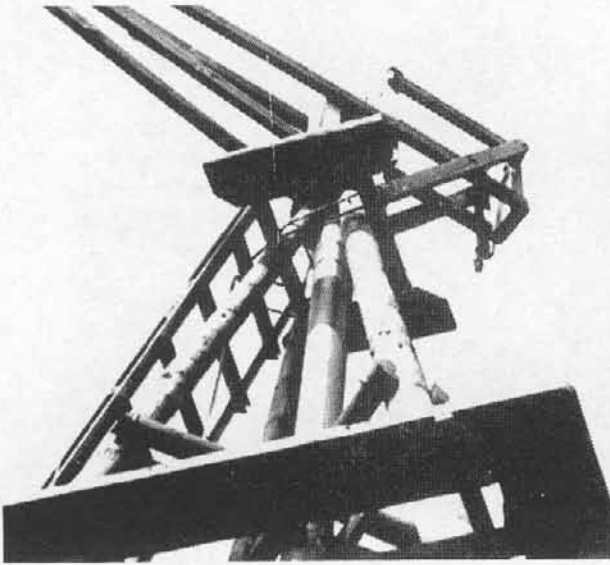

Fig. 3.21



de pas gemonteerde kopkonstruktie  
mounted headconstruction



de draagschijf met plaatstalen ring  
bearingdisk with sheetiron washer

By means of two countersunk screws the brake disk is tightened into the hub beam of the sail support, after that the two halves are tightened around the axis by means of the two studs.

The rotor support itself is fixed to the mill by means of a pin (with a minimum diameter of 10 mm) which is driven through rotor support and axis at once.

### 3.6. The rotor

It is clear that "measuring and fitting" of the head construction will be easier to do on the ground.

Only when the moving parts and the brake system function satisfactorily, should the frame be erected on the tower which has already been erected. The next step is the construction of the rotor support and the sails. After finishing this job, the rotor with the rotor shaft can be mounted on the head construction. See sections 3.7. and 3.8.

#### 3.6.1. The sail frame - the rotor support

Before the eight 3 m long rotor-poles are fastened to the centre supporting frame, holes must be bored in the poles. This for threading the sails.

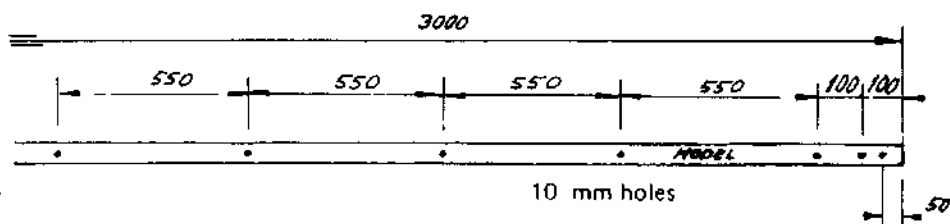

Fig. 3.22

The best way is to make one pole first, as illustrated in figure 3.22., after which this can be used as a model.

Using the model-pole the holes can be copied on the other poles and transferred to the sails, as will be dealt with later on.

Fig. 3.23. shows how the poles are mounted on the centre rotor support. It is advisable to fasten the ends of the poles to the hub beam with ordinary short wood screws, while for the attachment of the supporting frame threaded studs are used.

Washers under the bolt-heads and nuts should be chosen larger than normal, in order to avoid bruising.

The assembly will be easier if the supporting frame together with the brake disc and the rotor shaft are supported horizontally on a table. The rotor shaft must reach out at least 2.50 m in front of the supporting frame for guying the rotor poles. This front-shaft is necessary for reason of rigidity of the rotor itself.

If such a long shaft is not available then another, less thick, can be used by inserting this smaller pipe into the rotor shaft. The smaller

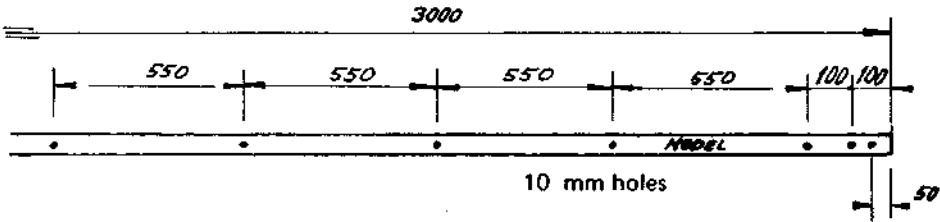

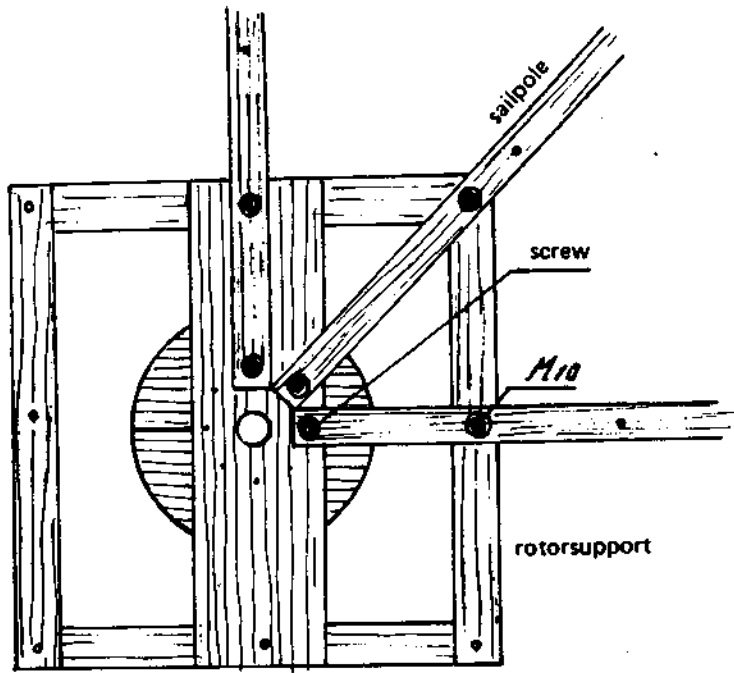

Fig. 3.23

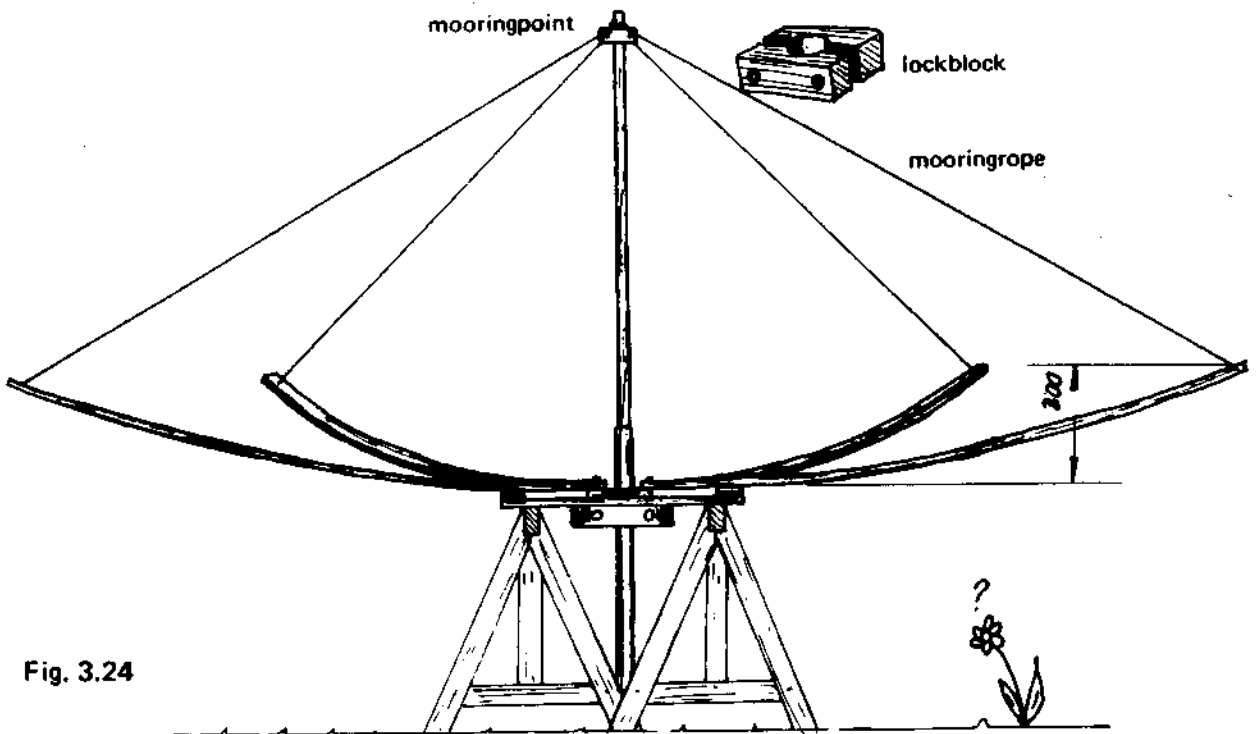

Fig. 3.24

pipe must fit inside the larger axle pipe without rattling. This extension pipe may be fastened to the rotor shaft using the pin through the hub-beam and the rotor shaft, as was dealt with in section 3.5.

After the rotor poles are mounted on their central supporting frame, their guy ropes are tied.

These guys are tied in such a way that the sail poles are bent up by about 300 mm (see figure 3.24.). For conveniency one rotor pole is again chosen as model.

An extra rope is used to check that all the poles are bent up the same amount.

This extra rope is fastened to the centre point.

The reasons for bending the rotor poles are twofold:

- to leave enough space for the movement of the sails at the altitude of the platform
- to reduce the bending stress in the rotor poles near the supporting frame at high wind speeds

If rope is used for the guys then a durable type should be used.

When the rotor is assembled to the head construction, the replacement of the guy-ropes will be very complicated. For this reason it is advisable to use a type of rope with a long lifetime. This demand of lifetime is also of value for the knots.

It is advisable to make double knots at the centre point (figure 3.25a).

Figures 3.25b and c show how the knots in the last but one hole in this pole are to be made.

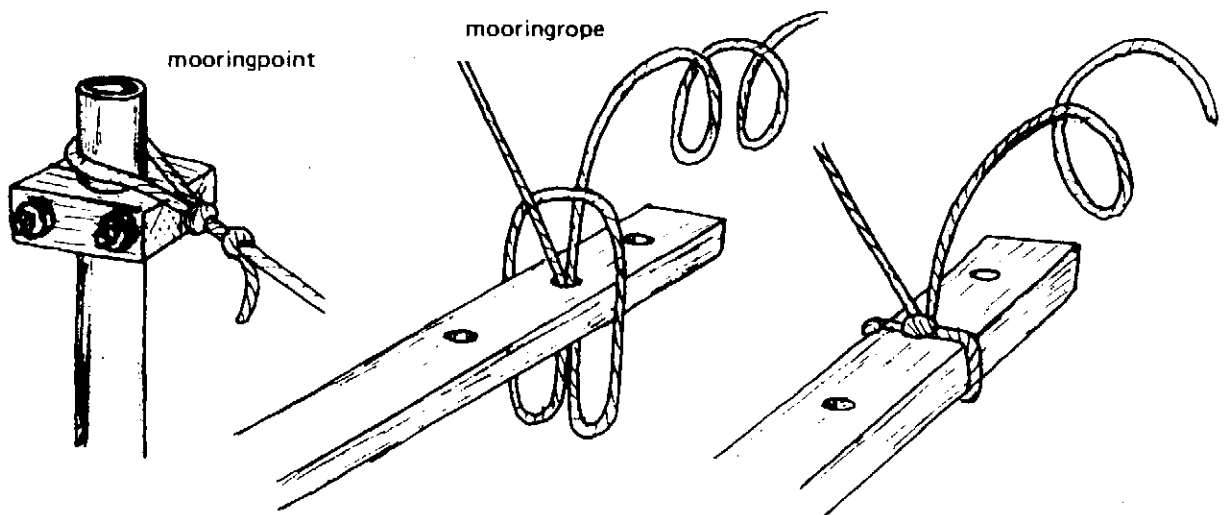

Fig. 3.25

Enough guy rope must be left after knotting, to make it possible to tie the sails onto the rotor poles.

As the sails will be rigged between one pole and the next, the poles must form a rigid regular eight sided figure. This is realised by tying the tips of the poles to each other with a rope as is shown in figure 3.26.

About 20 m rope will be needed for this. This rope must be tied just so tight that a regular eight sided figure will result.

Now the sail support frame is ready for rigging the sails.

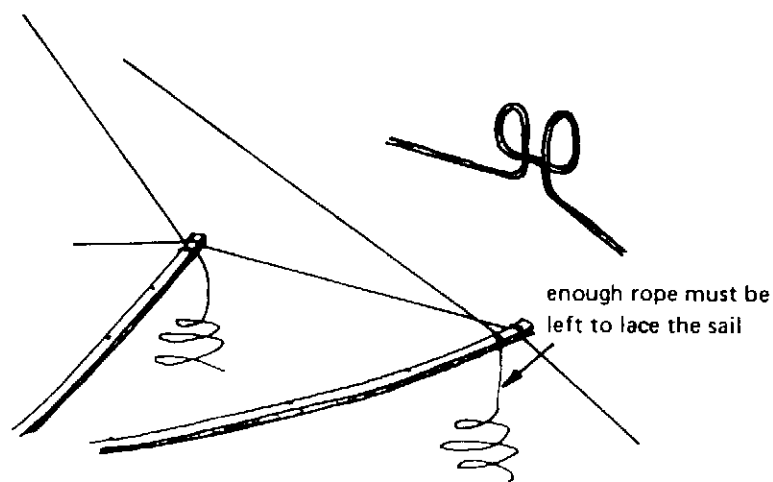

Fig. 3.26

### 3.6.2. The sails

It may be generally stated for sail windmills that half the area swept by the poles must be covered by sails.

Plasticised canvas (the canvas covers of lorries) is excellent material for the sails (strong and weatherproof). If this material is not available then other.

Suitable material should be chosen. This alternative material should not split easily nor stretch under tension (as plastic sheeting will). Fraying of the canvas may be prevented by sewing seams along the edges. The sails are fastened to the poles by lacing with the ends of the guying ropes.

To do this, round holes are cut in the sail canvas on the longest side of the triangular sails.

To prevent possible tearing at these holes they are reinforced with sail rings.

In figure 3.27. ways of measuring, cutting out and rigging (fastening) the sails to the rotor poles are shown.

It is very important that the threadrow is made at the front side of the profile.

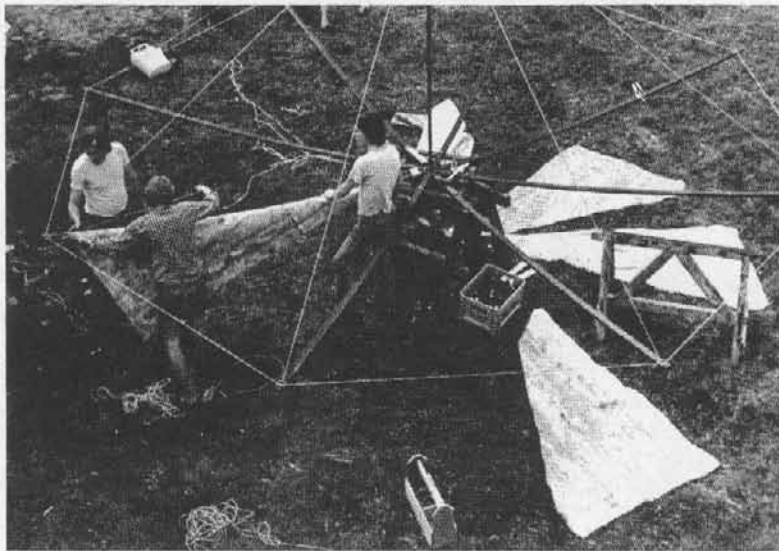

het vastrijgen van de zeiltjes  
lacing the sails

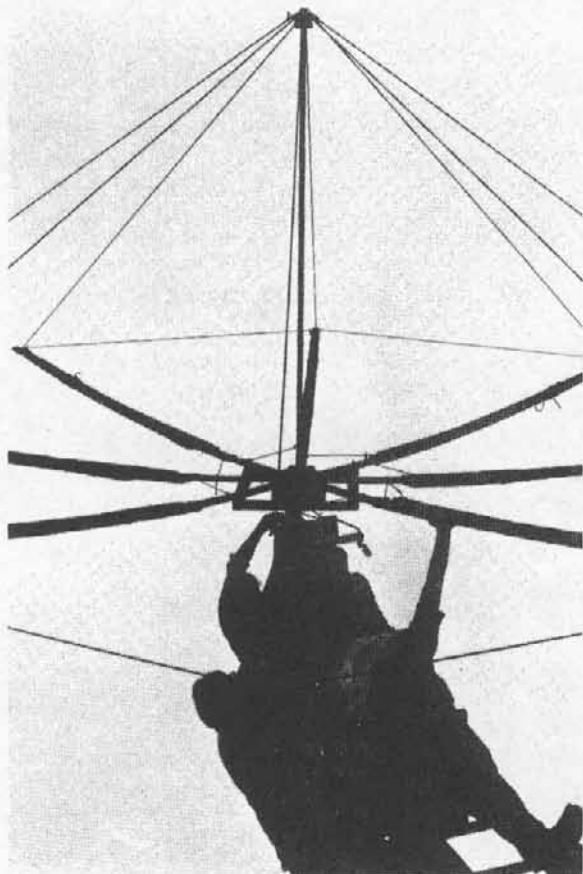

het plaatsen en controleren van het wiekenstel  
mounting and inspection of the wings



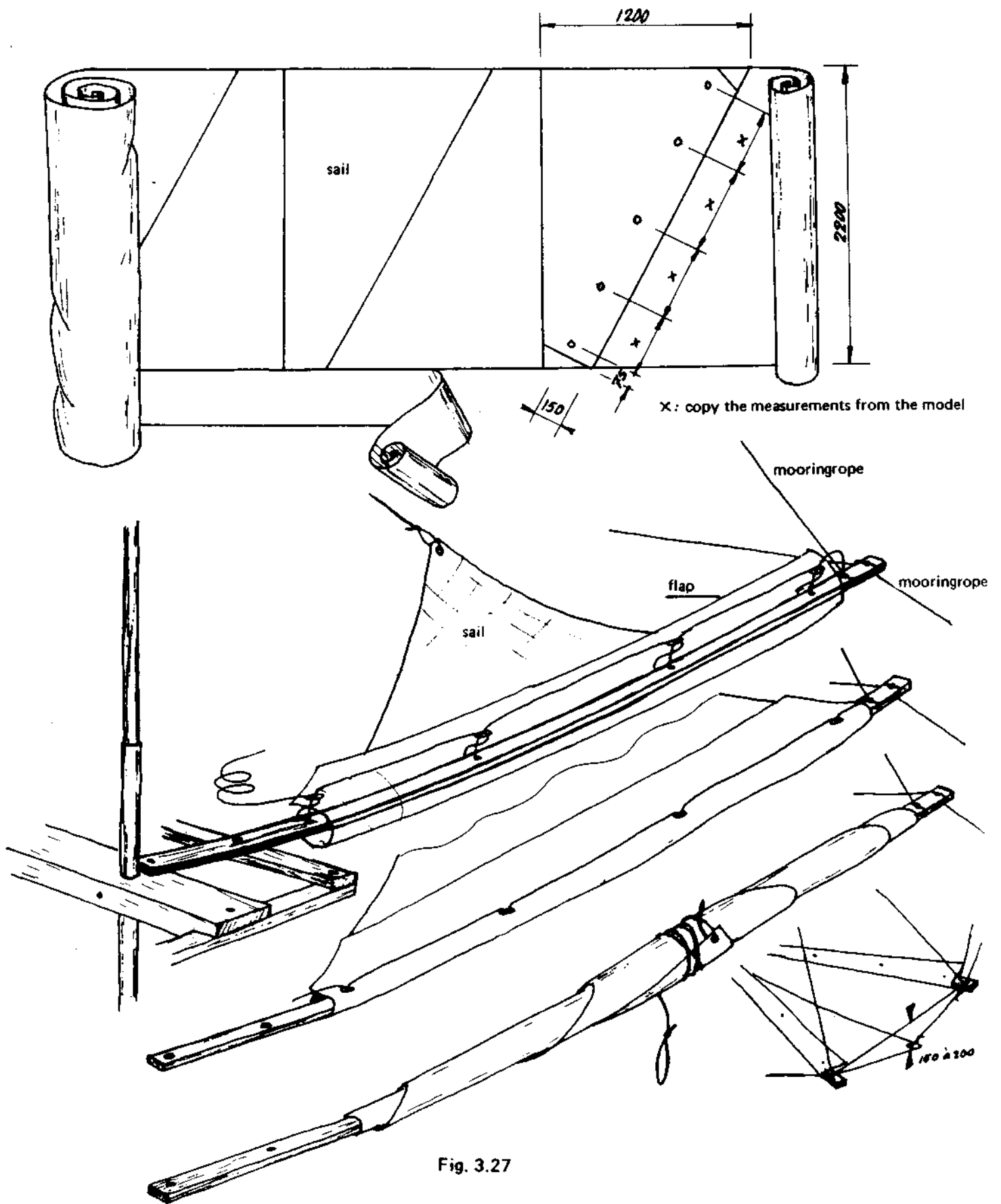

Fig. 3.27



The sail is rigged in such a way that it passes behind the rotor pole towards the next pole. The flap at the front smooths out the air stream, so allowing a sort of aerodynamic profile. With the aid of the sheet-rope fastened at the pole point of the sail, it is possible to "set" the sail by putting the loop at the end of the sheet-rope over the end of the following sail pole. The tension in this sheet-rope must be such that the distance indicated in figure 3.27. is about 150 to 200 mm. The sail can be brought in the wind by attaching the rope end of the sail to the next pole, leaving a distance of the sail end of approximately 15-20 cm to the rope between the poles. See figure 3.27. The length of the rope end of the sail may be adjusted by knotting it several times if necessary. Later, experiments with the length of the rope may be successful. When all the sails are laced to the pole, the rotor is ready for assembly on the head construction.

### 3.7. Assembly of the head construction and the rotor

In section 3.2. we already explained how the tower is erected. We now assume that because of the ladder and the hand rail, the tower is accessible without risk. If this is the case the head construction and afterwards the rotor can be mounted.

#### 3.7.1. Mounting the head construction

The elevation of the head construction without tools and by manual power only is very risky. You should consider that in the top of the tower there is hardly any space or support for more than one person whilst the head construction must be lifted over the tower tube and put into the right position.

Do not take any risks and think of the damage and human suffering that can be the result of an accident. Take the effort to install a simple hoist on top of the tower to reduce the risk of accidents to a minimum. Such a hoist can be made from a ladder which in a vertical position is lashed by a rope to the tower at the level of the first and second platform. The bottom rung of the ladder rest on the beams of the lower clamping device of the tower tube.

One of the upper rungs can be used as a "pulley" by leading rope, which is used for raising the head, over it.

Fasten the end of the rope as near to the centre of gravity of the head as possible.

A few persons now push up the head and keep it free from the tower while others pull the rope (see fig. 3.28.).

The whole should be raised to such a level that its lower end is well above the top of the tube. Two persons standing on the upper platform should hold the head in the right position while it is lowered on the pipe. The ladder gives the persons in the top of the tower the same protection.

Do not forget to install the pivot ring before mounting the head.

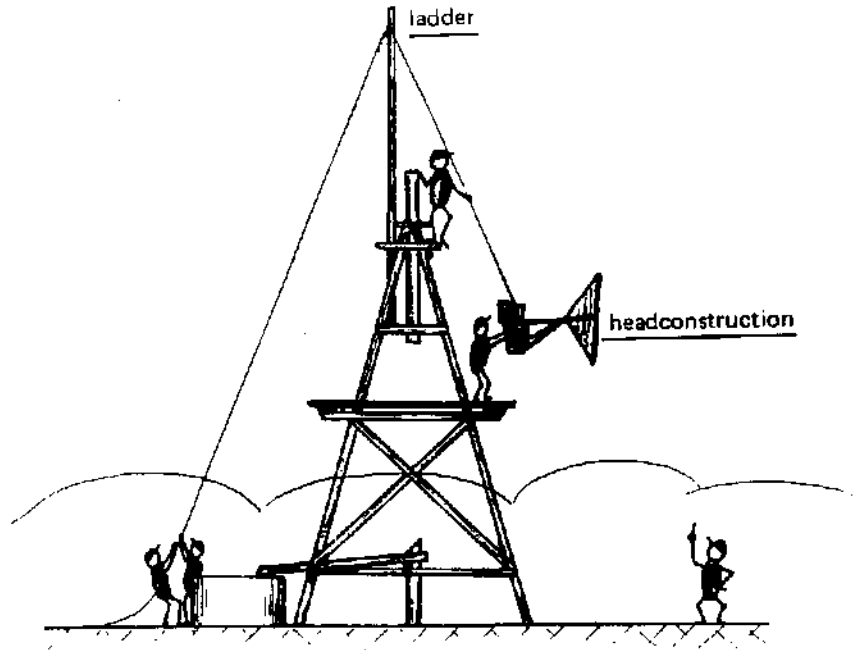

Fig. 3.28

### 3.7.2. The mounting of the rotor

---

Actually this mounting is carried out as described before. The rotor is placed gently at one side of the tower. We recommend to support several poles slightly so that the weight of the rotor will not be supported by one or two poles only. Remember to put the pivot rings behind the brake disc before hoisting. To prevent them from slipping off the shaft while hoisting, they can be fastened as shown in fig. 3.29.

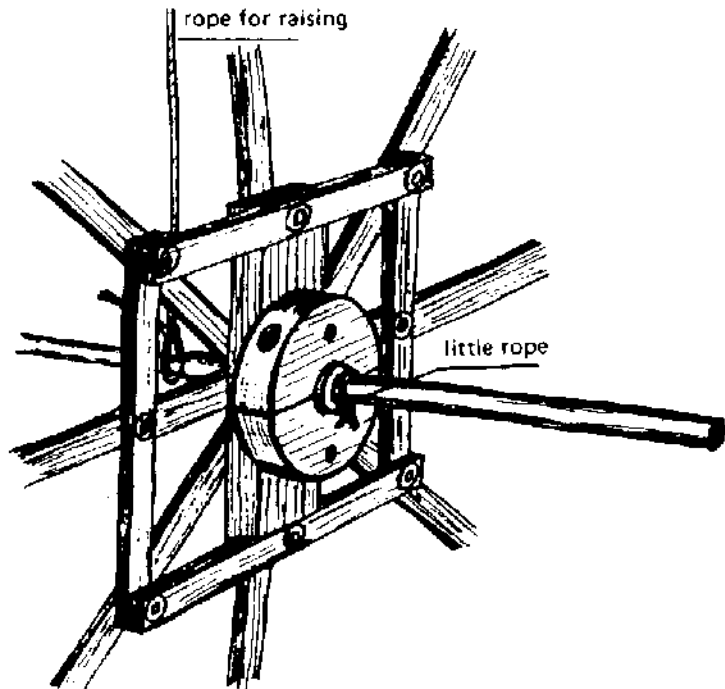
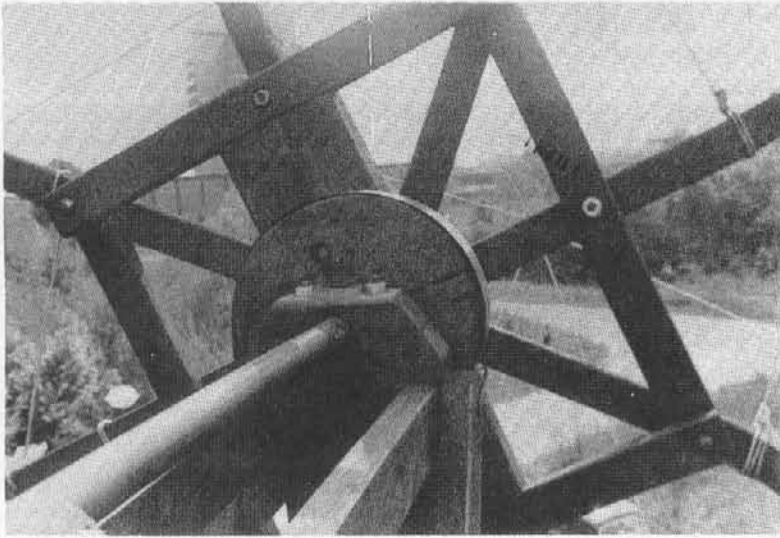
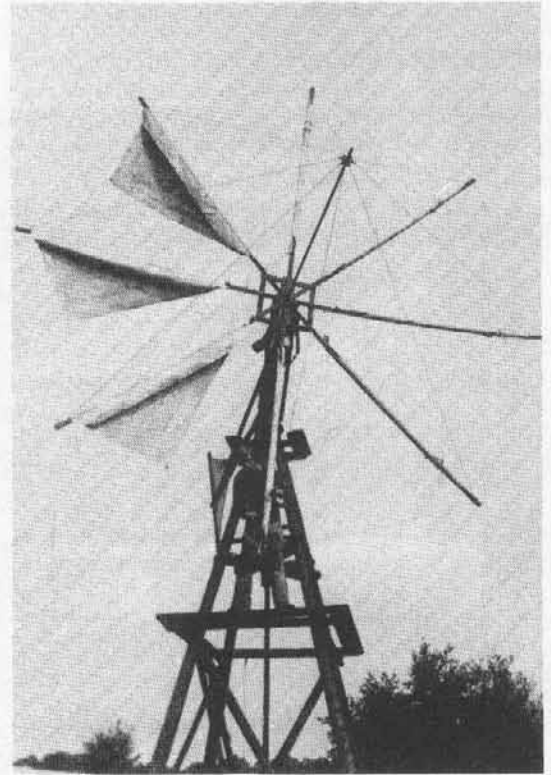

Fig. 3.29



achteraanzicht van het wiekenraam;  
duidelijk is het voorste lager te zien  
rearview of the wingframe; the frontbearing is clearly visible



het uitzetten of oprollen van de zeiltjes  
folding and defolding the sails

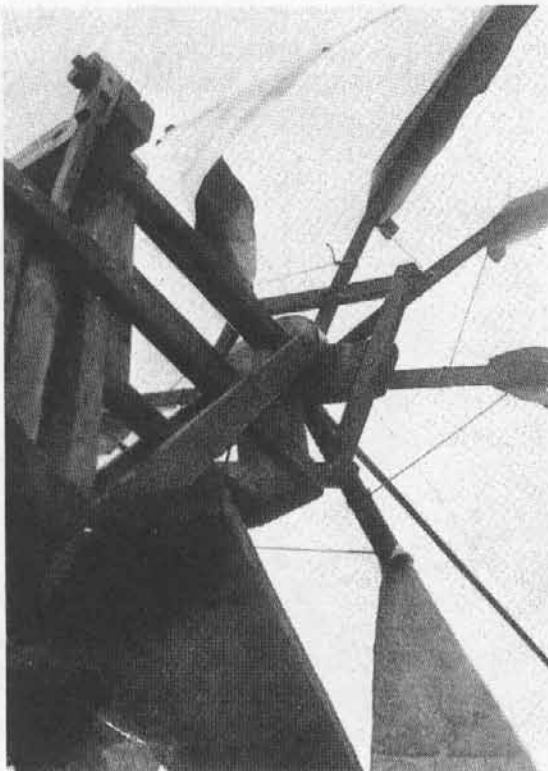

aanzichten van de kopconstructie  
views of the headconstruction

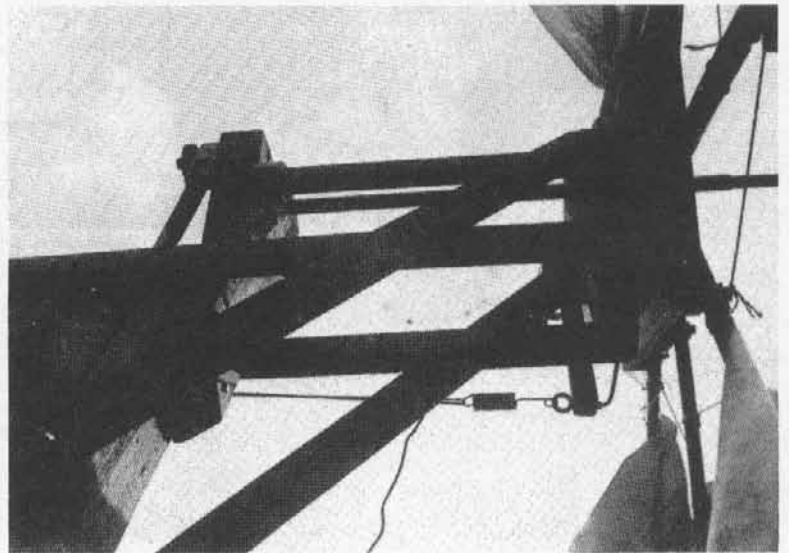

While hoisting we should take care that no guys get stuck behind a platform or any other protruding part of the tower.

As soon as the rotor shaft is resting in the lower bearings, the upper bearings should be mounted. See to it that the necessary tools, rings, washers and nuts are available.

### 3.8. Finishing and testing the mill

The crank, connecting rod, cross and piston rod can now be fitted. Do not forget the brake and lubricate the bearings with oil or grease. First try to turn the rotor by hand. See to it that no parts are touching others, while in motion, e.g. the brake disk the head construction, the crank against the frame or the connecting rod against the tower tube.

If everything is working properly, you can let the mill turn under its own (wind) power by setting out the sails.

Try the braking system and adjust if necessary by giving the spring more or less pre-tension.

We recommend to let the mill turn for a few hours without pause to let the pump carry off the sand which was brought down by the ground water. Stop the mill as few times as possible but if necessary as briefly as possible because otherwise the sand will settle on the foot valve and piston. Sand columns of 20 to 30 cm on the piston are no exception. During the test period the mill should be stopped occasionally to find the optimum position of the crank-radius suited to the wind speeds occurring and any adjustment of the tension in the rope ends of the sails.

Alternatives can be made according to your own insight.

Tips for the rational use of the mill:

- Make a few persons fully responsible for the use and maintenance of the mill.
- If braking the mill is necessary, do it gently and not suddenly.
- Each time before putting the mill into operation all parts should be lubricated (oil and grease) first. Stick to the rule "lubricate often with a little grease rather than seldom with a lot".
- Check all bolted connections periodically. Wood shrinks and therefore the tension in the joints diminishes.
- Try to prevent neglect of or attack on the wood by applying impregnating compounds, tar products or paint.
- Due to the fact that the mill is not automatically secured against storm, somebody should always be at hand to reef the sails when a storm or very strong wind springs up.

Practical tips for mounting:

- Always drill holes for bolted connections. If one of the parts is split a connection of timber is worthless.
- Always use fair sized washers under the heads of the bolts and nuts when joining timber, to prevent damage to the wood.
- Lightly plane rough-sawn wood and level the edges (beware of splinters).

- Always drill the holes in the two parts of timber joints always in one action.  
The bolts always fit.
- Provide a fair set of (hand) tools. Good tools are half the job (nothing is more annoying than working with blunt and defective tools).
- Keep people away from beneath the mill when work is carried out in it (falling parts or tools). By the way, a box nailed to the tower is very useful for putting away tools.



het proefdraaien  
the testing

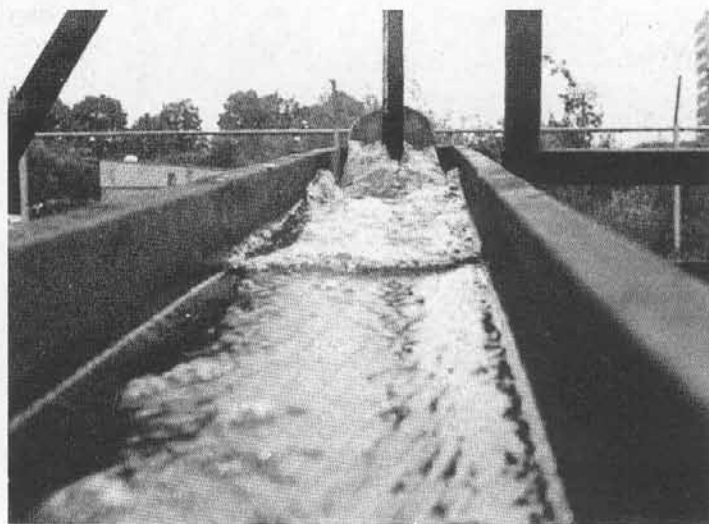
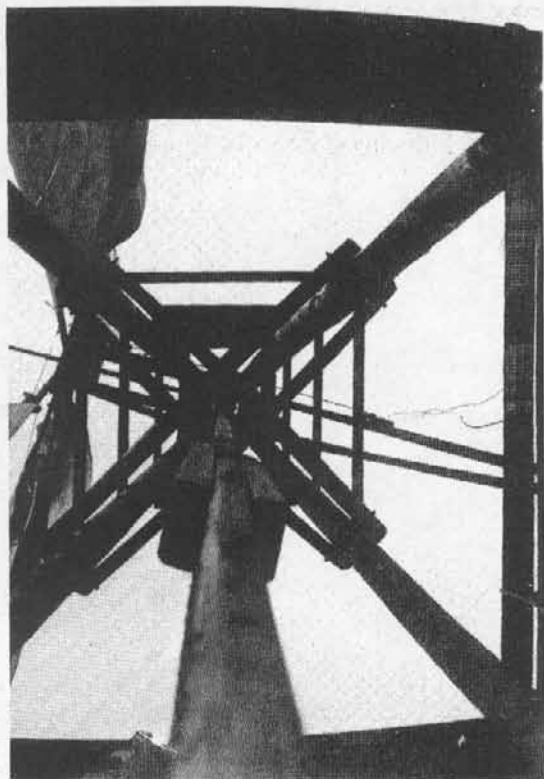

Annex Material

Name	Material	Number	Size (in mm) and remarks	
<u>Wood-working lathe:</u>				
Frame	wood	2	80 x 80 x 1500 bed	
	wood	2	50 x 160 x 1200 vertical beam	
	wood		lathes 25 x 50	
Tailstock	wood	1	50 x 160 x 160 and lathes	
Tool rest	wood	1	50 x 160 x 120 and lathes	
Spindle			from bike frame	
Bicycle wheel		1		
Pedal crank mechanism		1		
Disc	wood	1	built up with planks $\varnothing$ 300 mm	
Disc	wood	1	$\varnothing$ 150 mm	
Pedal	wood	1	25 x 50 x 1500	
Bracket	steel	1	$\sim$ 250 mm	
Sundries		-	woodscrews, nails, threaded bars and nuts	
<u>Drilling-tool</u>				
Tripool	log	-		
	wood	3	$\varnothing$ 80 x 3 m, roped or connected with threaded bar	
Drill rod	pipe	1	$\varnothing$ 35 x 6 m	
Disc	steel	1	$\varnothing$ 200, thick 3 mm, weld or rivet to pipe	
Cross rod	steel	1		
Pulsing rod	steel or	1	$\varnothing$ 120 x 0.5 m	
	PVC			
Leather valve	leather	1	120 x 200	
Steel plate		1	120 x 200 for strengthened valve	
Rivets	steel	$\sim$ 10	$\varnothing$ 3 mm for strengthened valve	
Rod push	wood	-	25 x 50, as long as necessary	
Sundries		-	woodscrews, nails, threaded bars and nuts	
<u>The bore-hole</u>				
Drainage pipe	PVC		$\varnothing$ 150, as long as necessary	
Filter-bed material		-		
Lattice	wood	-	25 x 50, instead of the utilisation of sockets	
Sundries	-	-	screws for the assembly of the lattice to the pipe	
<u>Pump:</u>				
Pump cylinder	PVC or steel	-	lengths as following:	
			diameter	head
			150 mm	3 m
			120 mm	4,5 m
			100 mm	6,5 m
			80 mm	10 m
			70 mm	12,5 m
			60 mm	18 m
			50 mm	25 m
Piston	wood	1		
Valve	wood	1		
Sealing	leather	1	depends on pump diameter of cylinder	
Valves	leather	2	depends on pump diameter or cylinder	
Piston rod	wood	-	25 x 50, as long as necessary	
Gutter	wood	1	planks	
Sundries		-	screws, nails, etc.	

Name	Material	Number	Size (in mm) and remarks
<u>Tower:</u>			
Poles	log	4	∅ 100 - ∅ 150; length ~ 7 m
	half round logs	12	½ ∅ 100 ; length ~ 3 m
	wood	4	30 x 200 ; length ~ 2 m
1st Platform	wood	4	30 x 200 ; length ~ 0.8 m
2nd Platform	wood	2	30 x 200 ; length ~ 0.8 m
Ladder	wood	1	2 steps: 80 x 80 length ~ 3 m lattice: 25 x 50 (steps) length ~ 4 m
Handrail and steps	wood	-	lattice: 25 x 50 (steps and handrail) length ~ 6 m
Tower tube	steel	1	∅ 140 length ~ 2.5 m
Sundries		-	screws, nails, threaded bar and nuts
<u>Head construction:</u>			
<u>Frame:</u>			
-----			
Legs	wood	4	30 x 80 length ~ 6 m
Beams	wood	4	50 x 160 length ~ 0.7 m
Tail-lattice	wood	2	25 x 50 length ~ 1.25 m
Tail	canvas	1	1.5 x 1.5 m; if necessary the sails must be bordered
Sundries		-	screws, nails, threaded bar and nuts
<u>The moving parts:</u>			
Bearing blocks		4	70 x 70 x 200
Rotor-shaft	steel pipe	1	∅ 50 length ~ 3.5 m
Crank	wood	2	55 x 110 x 400
Connecting rod	wood	1	30 x 30 x 600
Cross head	wood	2	110 x 30 x 400
Wearing plate	steel plate	2	350 x 130; thick 1 à 1.5 mm fixed with screws
Crank pin	tube	1	∅ 25 x 200
Cross pin	tube	1	∅ 25 x 130
Washers	steel	3	∅ 80 x ∅ 50 ~ 2 mm thick
Washers	steel	4	∅ 60 x ∅ 25 ~ 2 mm thick
Sundries		-	screws, threaded bar and nuts
<u>Brake:</u>			
Belt	steel	1	1 x 60; length ~ 1 m
Disc	wood	2	60 x 160
Pullspring	steel	1	
Lever	wood	1	bars: 30 x 30 length ~ 700
Sundries		-	screws, threaded bar and nuts
<u>Rotor:</u>			
Hub beam	wood	1	60 x 160 x 600
Bars	wood	4	30 x 60 x 600
Sail bar	wood	8	40 x 50 length 3.20 m; the end of the bars must be rounded
Rope			∅ 6 mm length ~ 90 m
Sail	canvas		~ 12 m <sup>2</sup> ; if necessary the sail must be bordered
Pin	steel	1	∅ 10 mm; length ~ 160 mm
Sundries			screws, threaded bar and nuts, washers



