

The New Alchemy Sailwing

— Earle Barnhart and
Gary Hirschberg

Over the past several years we have been investigating the applications of wind-powered water-pumping systems. We have been particularly interested in sailing windmills which generally can be constructed of indigenous materials with limited equipment by people who are not trained specialists. In contrast to more sophisticated designs, sailwings can be adapted to places poor in resources such as rural areas or third world countries. Windmills have been used for irrigation for more than twelve centuries in areas where cultivation would be otherwise unfeasible.

At New Alchemy on Cape Cod we needed a water-pumping system for aquaculture projects and to irrigate the gardens. We wanted to design a windmill that could be constructed by a do-it-yourselfer using local and/or available materials. It was important that our water-pumping system be simple and inexpensive, require very little maintenance and be storm-resistant. The windmill had to be adjustable for varying wind speeds and wind directions. It was essential that it be operative in areas of low wind speeds for it to be broadly practicable.

Four years of experimentation and research, beginning with Marcus Sherman's bamboo/cotton sailing windmill in Southern India, have culminated in the design and construction of the New Alchemy Sailwing which meets these objectives. Familiarly known as "Big Red" (Figure 1), it was named for its first set of bright red sails. It pumps in winds as low as 6 miles per hour and in gales of up to approximately 40 mph. Although our water-pumping needs do not extend into the winter, the Sailwing is operable throughout the year. People with year-round demands need only take normal cold weather precautions against pump or water-pipe freezing damage.

Sailwing Description

On top of the 26-foot wooden lattice tower, a horizontal axle leads to the junction of three steel masts (Figure 2). The multi-colored Dacron^(R) sails are attached to the masts by grommets and pegs, like the rigging of a sailboat. Elastic shock cords connected to the adjacent mast pull the sail root out to form a smooth surface for catching the wind. The shock cords allow for self-feathering and easy furling in storm conditions. The sail tips are attached to fixed triangular pieces at the ends of each mast.

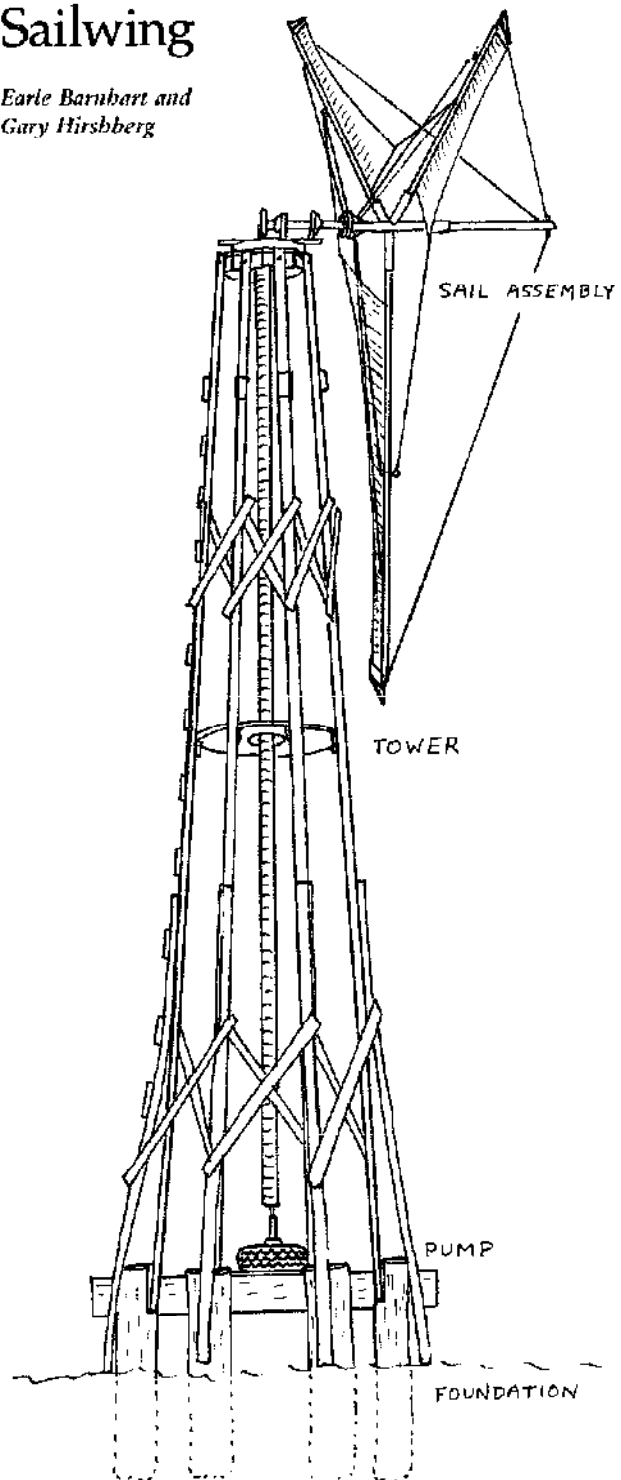

Fig. 1

All drawings by Earle Barnhart

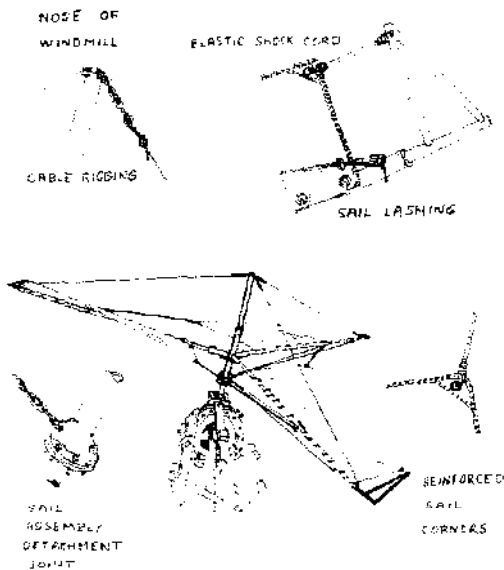

Fig. 2

The axle and sails are oriented downwind from the tower, eliminating the need for a tail. Wind power is transferred along the rotating axle through a pair of sealed commercial bearings (Figure 3). A steel disc crankshaft mounted at the base of the axle transfers the axle rotation to the vertical motion of the pump shaft. Five distinct stroke settings are provided by holes drilled at different radii from the disc center. The assembly is centered on a steel plate turntable above the tower. The adjustable stroke disc is centered directly above a hole in the turntable through

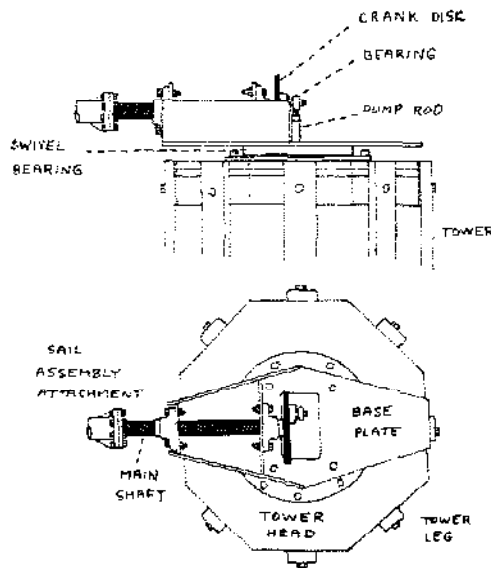

Fig. 3

which passes the pump shaft. From the disc, power is carried down the tower along a three-inch diameter shaft to a diaphragm tire pump at ground level (Figures 4 and 5).

The windmill tower is made of eight 2 x 4 legs bolted to buried sections of telephone pole. Curved wooden buttresses add support at the base and two sets of latticework give additional stability above. A secondary platform rests approximately halfway up the tower.

Origins of the Sailwing Windmill.

A brief look at windmill history indicates that the New Alchemy Sailwing is a scion of considerable heritage. The origins of windmills are somewhat obscure, but primitive horizontal mills are thought to have been employed in seventh century Persia. Legends recount that prisoners of the Genghis Khan carried the idea of wind-powered grinding and water-pumping mills to coastal China. There, horizontal mills with matted sails came into use. These primitive mills became obsolete by the end of the twelfth century as the application of Chinese sail-making increased the sophistication of windmill construction. The sailwing had an unparalleled maintenance-free life-span due to its durability and simple, lightweight design. It gained widespread application throughout coastal China. The same criteria explain the ubiquitous employment of sailwings in China and Southern Asia today.

The European windmill developed independently of its Asian counterpart. The first documented mill was used for grinding grains in England during the latter part of the twelfth century. By the seventeenth century, due largely to the extensive exploitation of wind both on land and sea, the Netherlands had become one of the wealthiest nations in the world. Cloth was the commonly-used material for windmill sails during this period, reflecting its application on sailing ships. Among the advantages of cloth were light weight, ease in handling, low cost and availability. Most importantly, when supported at three or more points, cloth forms a strong uniform surface for catching the wind.

These advantages hold true today, as is evidenced by the widespread use of cloth for windmill sails. Currently, handcrafted sailwings are employed in Crete, India, Ethiopia, China and Thailand, among others. Researchers at Princeton recently have developed a two-bladed high-speed aerodynamic Dacron^(R) sailwing for use in the United States.

1973:

Marcus Sherman and Earle Barnhart first experimented with sailwings at New Alchemy in the summer of 1973. They devised a three-bladed wood/canvas sail propeller which was used for driving pumps and power tools. Although this model was destroyed by a January

ice storm, Marcus was encouraged by the simplicity and efficiency of the sailing concept.

1973-1974:

In Southern India that winter, Marcus built his first water-pumping sailing windmill. There local farmers were experiencing hardship induced by the vagaries of monsoon-related droughts and flooding. Inadequate and costly power sources made reliable irrigation difficult. There was, however, a large untapped supply of groundwater. This prompted Marcus to consider harnessing the wind for irrigation on the farm of a friend. To complete the irrigation system, scientists at the Indian Institute of Agricultural Research in New Delhi recommended a modified paternoster pump, like that used to drain the mines in Britain in the late sixteenth century, because of its simplicity and low-cost construction. Chain pumps such as this work well with the relatively slow and variable power that is characteristic of windmills.

Marcus developed a mill that was a hybrid of the low-speed, eight-bladed Cretan sailing and the high-speed aerodynamically-efficient Princeton model — "A Windmill in India", the second *Journal*. Using a bullock cartwheel roughly one meter in diameter as the hub, he attached to it triangular sailing frames made of bamboo and nylon. A cloth sail was stretched over the frame to produce a stable, lightweight airfoil. The rotor assembly was attached to a used automobile axle. Marcus made a turntable from ball bearings sandwiched between two doughnut-shaped discs. The axle was mounted horizontally on top of the turntable. A rudimentary "squirrel cage" assembly for housing the drive chain and gasket pump was centered on the axle directly above the one-foot-diameter hole in the turntable.

The sailing was headed downwind to prevent the bamboo poles from bending and striking the teak pole tower in monsoon winds. In this way the blades served as their own tail, trailing in the wind. In the process of the subsequent well digging, the mill was used with a pulley assembly to raise soil and rock from the 20-foot-deep well. Because of its high starting torque at low wind speeds, the mill proved well suited for year-round irrigation in Southern India.

1974:

Back at New Alchemy the following summer, Marcus, with Earle, gave the sailing concept another try. With lumber and hardware, they built a durable prototype well able to withstand the often blustery Cape Cod climate. For a total material cost of \$300, they developed an 18-foot-diameter, cloth sailing capable of pumping 250 gallons per hour in 6 mph winds. Three tapered cloth sails, supported by tubular steel masts, extended from a triangular plywood hub. A moveable boom was secured at the

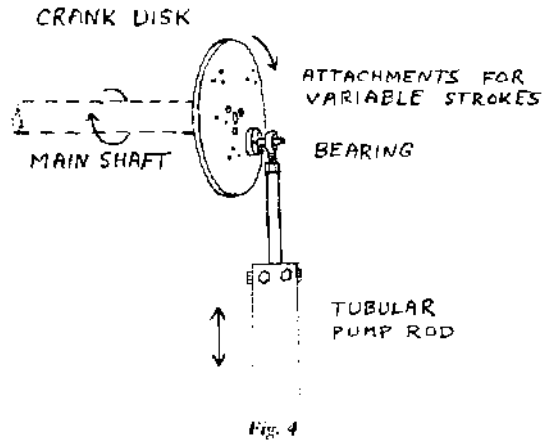

root of each sail by a leather strap to further self-feathering. Long metal doorsprings connected each of the three sail booms. In early tests, the feathering mechanism withstood a force-nine gale.

A used automobile crankshaft formed the hub and crank. The assembly turned on a ball-bearing turntable which allowed the windmill to seek a downwind operating position. A recycled piston rod on the crankshaft transferred power to a reciprocating vertical steel pipe pump shaft. The shaft operated a high capacity piston-type pump below. The entire struc-

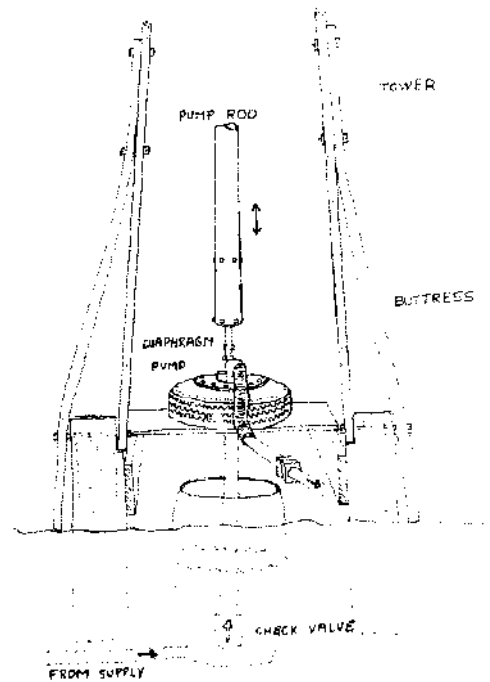

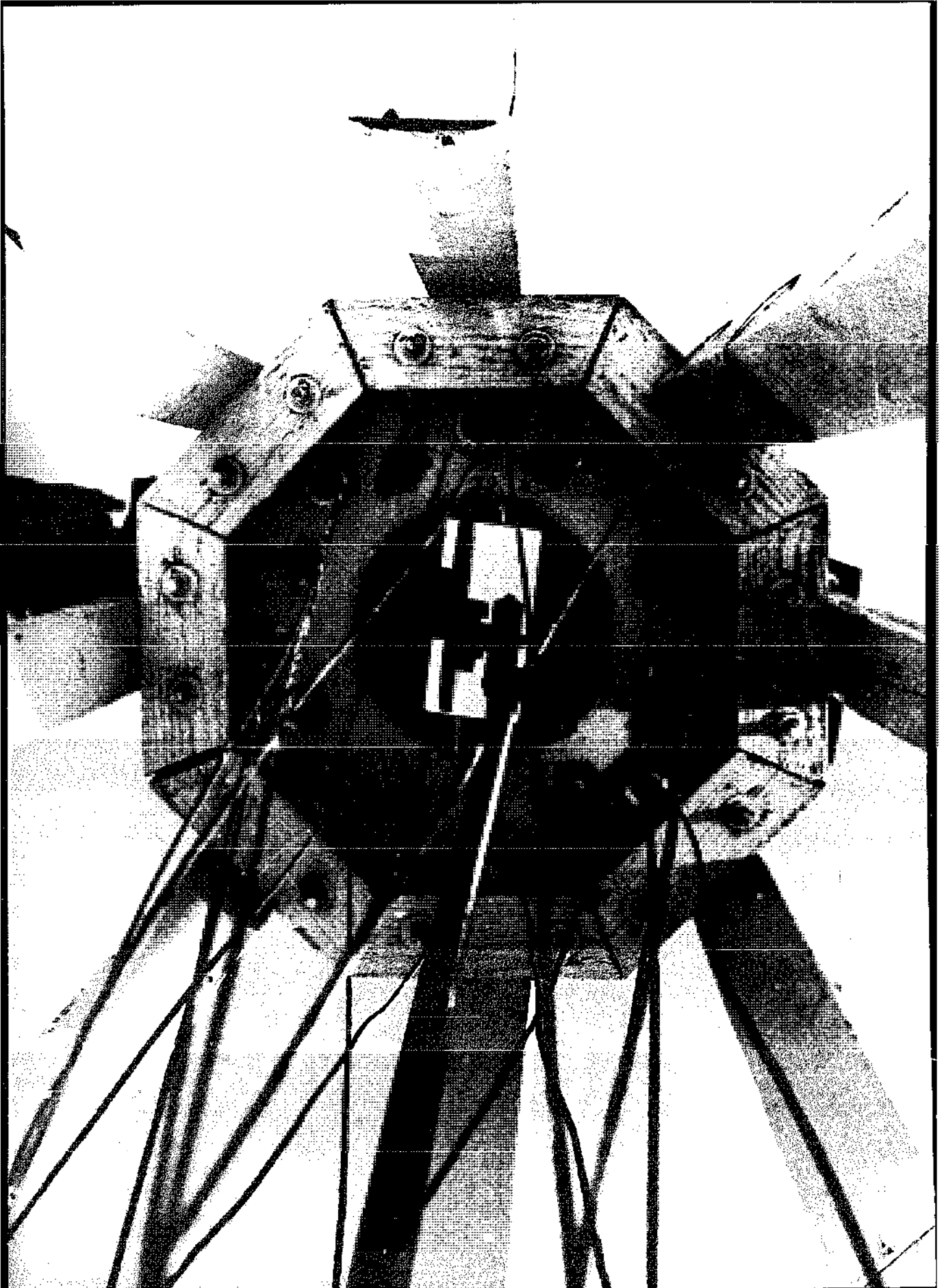

ture was mounted on a firmly-braced eight-legged wooden tower.

The windmill supplied water to a series of twenty small ponds used in our ridge experiments. It was operational in high winds, although the cloth sails were removed in severe storm conditions. The cotton sails were later replaced by Dacron^(R), which is longer-lived, holds its shape better, does not absorb water during rains and is stronger and lighter than cotton. On preliminary testing, Marcus found the performance of the mill to be significantly lower than its calculated pumping capacity. A double pump was used. This and subsequent models employed downwind sailing blades which minimize the chances of the sails tangling in the tower while feathering and eliminate the costs of a large tail.

1975-1976.

The current model was built in 1975 and incorporates many of the features of its prototypes. Several new ideas were tried. An extension shaft was added to position the hubs and blades further from the tower. We had noticed that the slip-on sock-like sails frayed where they were wrapped around the blade shaft. Traditional sail makers advised us to attach the sails with grommets and pegs and to position a stabilizing cable from wing tip to hub to prevent flexing of the blades. In addition, we added a simple spring-feathering device to each of the sailing tips.

The double pumps used previously with the prototype proved undersized for the strength of the new model, so a higher capacity and more compact diaphragm pump was tried. Tests were also carried out with a deep wooden piston pump like a marine bilge pump, but the diaphragm was more reliable.

The auto crankshaft that made up the hub and crank on the prototype was found to yield too small a stroke for the mill, so Mac Sloan, an engineer who advises us on windmill problems, devised an ingenious disc-bearing assembly to drive the pump (Figure 3). The disc/bearing assembly functions as a crank with a variable pumping stroke. Sealed commercial bearings were added to the windmill shaft at this time, as the original homemade bearings wore too quickly and demanded frequent lubrication. Curved buttresses were attached to the tower legs to support the additional weight of the crankshaft, extension and other hardware which had been added subsequent to the original design.

1976-1977:

Several other features have been improved since the spring of 1976. Strong elastic shock cords have replaced the door springs used for self-feathering, resulting in increased flexibility and smoother sail motion. The shock cords are easier to maintain and preclude the need for a boom.

Mac Sloan helped with another part of the present sailing system. He designed a smaller diaphragm pump, adjusted to the mill's one-gallon-per-stroke capacity. Once the pump was able to handle the mill's power, the pump shaft became the weak link. Excessive flexing in the half-inch pipe shaft led us to replace it with a rigid three-inch EMT shaft.

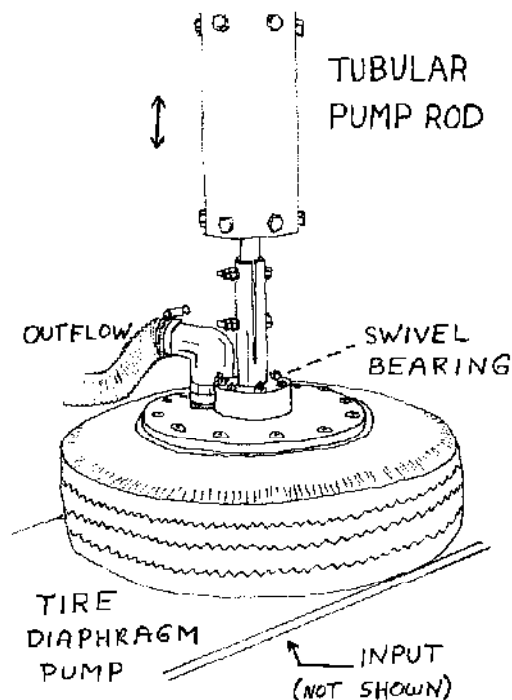

Fig. 6

Operation and Maintenance.

Self-feathering: In normal winds (0-15 mph) the taut sails catch the wind and drive the pump. In higher winds (15-30 mph), increased forces on the sail press downwind, stretching the elastic shock cord and allowing some of the wind to spill past the sail. This automatic feathering results in continuous pumping in higher winds without destruction of the blades.

Reefing: During very high winds and gales (> 30 mph) we protect the windmill by reefing the sails. The blades are stopped by hand from the mid-tower platform and each elastic cord is unhooked from its metal mast attachment. Each sail is wrapped around its own mast pole several times and then bound by winding the cord around the sail and hooking it. This arrangement leaves only a small triangle of sail exposed at the outer end of each mast, which in high winds is often enough to continue pumping.

Adjustments: Several adjustments can be made to adapt the windmill to different average winds or pumping requirements:



Photo by Hildi Mangav

The Pump Stroke - The pump stroke of the windmill has five settings depending on the attachment point of the pump rod to the crank disc. In a given wind, the windmill can perform a fixed amount of pumping work which can take the form of a low lift of high volume or a high lift of low volume. Our winds average 8-9 mph in summer and our need is to pump the largest volume possible to a height of four feet. Our custom-made diaphragm pump lifts .875 gallons per two-inch stroke in average winds. In high winds we have measured 700-800 gallons per hour.

Combinations of stroke-length, pump volume and height of lift must be developed for each application and site. Sailwing windmills such as this one have been used with piston pumps for 20-foot lifts/10-foot heads and with chain and trough pumps in Southeast Asia for low-lift irrigation.

Shock Cord Tension - The response of the windmill to varying winds depends on the tension of the elastic shock cord holding the sail taut. A mild tension aids operation in low winds by creating a steeper angle of attack as the sail partially feathers, but spills most of the higher winds. A strong tension reduces starting ability in low winds by creating a flat attack angle, but spills less energy in high winds.

Blade Tip Angles - The angle of the sail to the wind at the tip of each blade also affects the windmill in varying winds. A steep angle creates high starting torque but limits rpm once the windmill is turning rapidly. A flat angle give less starting torque, but once started causes a greater rpm in higher winds.

In our aquaculture circulation application, where continuous pumping is ideal, a mild shock cord tension and a steep tip angle of 40° results in low-wind starting and pumping as often as possible.

We offer these simple cautions in working with the mill:

- Stop the windmill and wear a safety harness while on the tower.
- Avoid allowing the windmill to free-wheel without a pumping load.
- Protect water lines from freezing for winter pumping.

We are, overall, well pleased with the New Alchemy Sailwing. It is beautiful, functional and durable. It performs well the task we ask of it. After four years, it meets the objectives we originally postulated and, in terms of cost, labor, efficiency and usefulness, when contrasted with more standard research and development models, it seems genuinely to qualify as appropriate technology.

An Advanced Sail-Wing for Water-Pumping Windmills

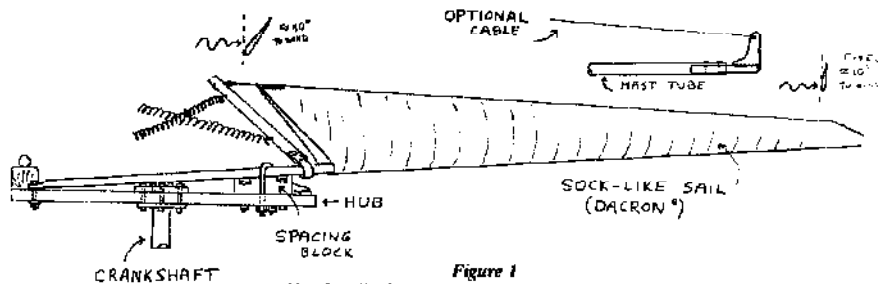

Figure 1
Simple sail-wing windmill details (one sail of three).

The development of sail-type windmills at New Alchemy was initiated by Marcus Sherman. The prototype was a water-pumping windmill which he had built in Southern India in 1972 to aid in irrigation. His windmill in Madurai used cloth sails, bamboo masts, teak pole tower legs and an ox-cart wheel (1). In 1973 Marcus built a similar windmill here on Cape Cod employing cloth sails to which had been added a spring-operated self-feathering mechanism (2). We have continued to develop the sail-wing windmill using it for aquaculture circulation and irrigation, and have found it to be, for our purposes, a workable and adaptable power source.

The vital part of the sail-wing windmill is the sail-blade, which consists usually of a fabric surface supported by a rigid mast. We have used Dacron (R) as a sail material because of its strength and durability. Figure 1 illustrates how the sail is slipped onto the mast like a sock and attached to the movable boom. The boom keeps the sail taut yet allows it to adapt to changes in the wind. Our first windmills had fixed-angle tips and feathering roots as illustrated.

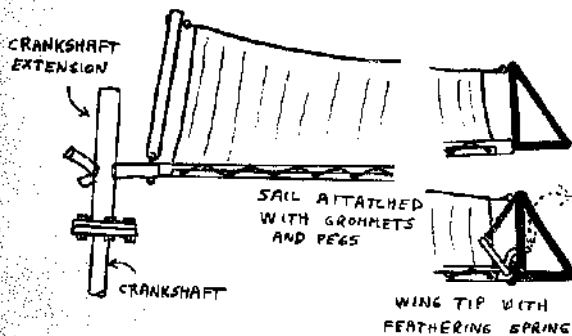

Figure 2
Advanced sail-wing details.

Figure 2 shows a later version of the sail-wing. An extension shaft holds the blades further from the tower. The sail is rigged with cord as on a sail boat, and the tip bracket has a feathering mechanism. Figure 3 shows how stabilizing cables may be positioned to prevent flexing of the blades.

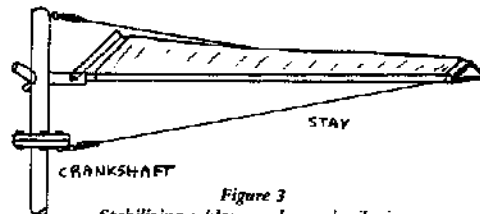

Figure 3
Stabilizing cables on advanced sail-wing.

The sail-wing windmill which we used for circulating water in the mini-ark in 1974 was strong enough to use two three-inch diameter piston pumps simultaneously. Figure 4 shows how the two pumps were connected by a swivel to the pump rod. The cast iron pumps were inexpensive. The packing boxes on each were fabricated from plumbing supplies (Fig. 5) (3). The double pumps were undersized for the strength of the windmill, however, and were replaced later by a higher capacity, more compact diaphragm pump which could be placed below ground (Fig. 6) (4). Figure 6 shows the buttresses on each leg of the windmill tower. It was felt prudent to strengthen the tower in order to give adequate support to the additional weight of the crankshaft, extension, cables and other hardware that were added subsequent to the original design.

The automobile crankshaft bearings used in the early windmills were adequate for the lighter type of blades, but required periodic lubrication on the

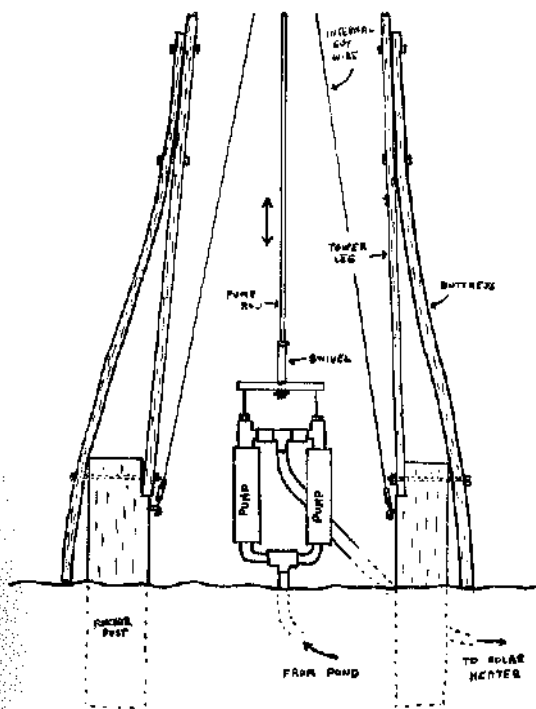

Figure 4
Sail-wing windmill with buttresses and two pumps.

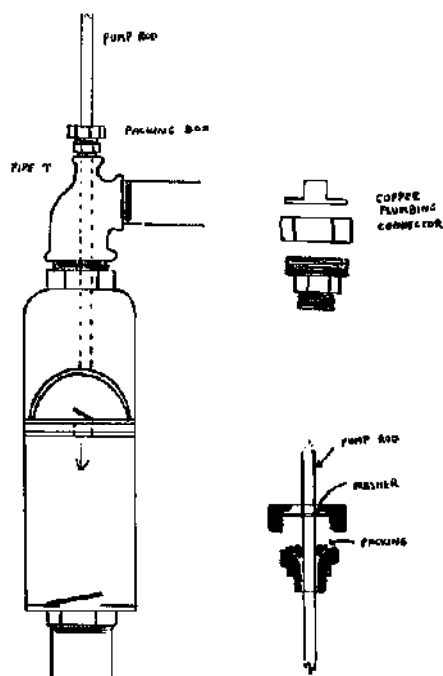

Figure 5
Inexpensive packing box for piston pump.

heavier models. Grease fittings are easily placed in each bearing clamp (Fig. 7). During one stormy period lasting several days, although there was no pumping load on the windmill, the extended period of high speed turning caused the bearing surfaces to wear through on the heavier blade end. It is advisable to balance the weight on each end of the crankshaft to maintain equal forces on the bearings.

The design for the latest windmill is moving into the realm of a heavy duty, long-lasting machine. Merrill Hail has constructed an experimental sail-wing windmill with several new features. The major change is that, for the first time, the blades face the wind. Previously, all of our sail-wings have trailed downwind. A tall, narrow tail tracks the blades into the wind. The main shaft, which has a two-inch diameter, runs in sealed bearings. Fitted to the end of the shaft is a plate on which a pin is fixed, offset from the shaft center point, to convert rotary motion of the shaft into cranking motion required for the vertical travel of the pump rod. The sail-wings are spring feathered at the base and centrifugally feathered at the tip. The results of these most recent innovations will be discussed after a season's operating experience.

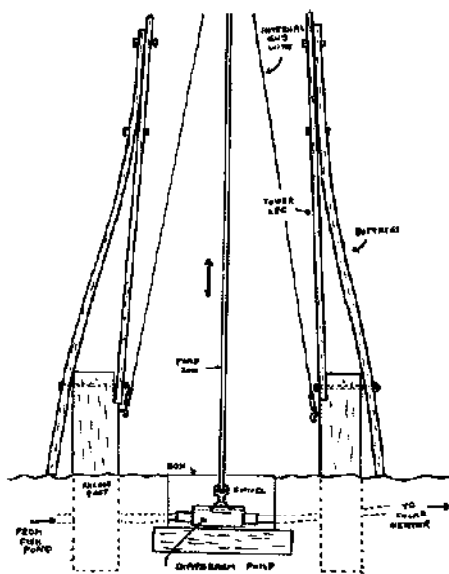

Figure 6
Sail-wing windmill with diaphragm pump.

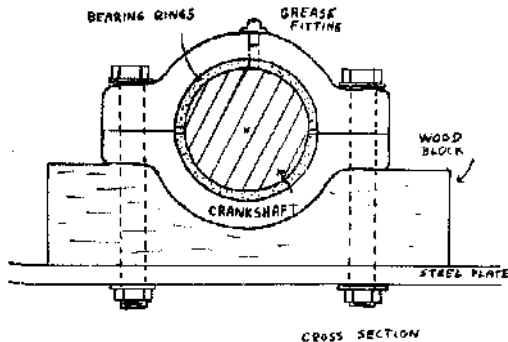

Figure 7
Windmill bearing showing grease fittings on crankshaft axle.

REFERENCES

1. Sherman, Marcus. 1973. "A Windmill in India." *The Journal of The New Alchemists* (1): 15-17 pp.
2. Sherman, Marcus. 1974. "A Water-Pumping Windmill That Works." *The Journal of The New Alchemists* (2): 21-27 pp.
3. Model No. 350 - Shallow Well Cast Iron Cylinder from Mid-West Well Supply Co., Huntley, Illinois - \$18.50 (1974).
4. Large capacity hand-operated diaphragm pumps, Edson Corp., Inc., 460 Industrial Park Road, New Bedford, Massachusetts - about \$100 (1974).

— Earle Barnhart



Savonius Rotor

One of the most reliable yet simplest windmills at the Cape Cod Center is the Savonius rotor. It is used to pump fresh water out of the ground into our open aquaculture pond, intermittently displacing a portion of the pond water and stirring it in the process. Our first experience with the Savonius rotor was with a simple rotor comprised of steel drums, based on the Brace Research Institute's design (1, 2). It worked well, but its small size resulted in a comparable limitation in power. In his original developmental work on the rotor Finnish engineer, Sigurd J. Savonius, eventually decided that semi-cylindrical wings such as those made with steel drums may not be as efficient as wings resembling a modified J (3, 4, 5).

When we decided on a second Savonius rotor, we built a larger more efficient rotor of three tiers, each oriented 60° from the others. This results in an even starting and turning force regardless of wind direction.

Each of the three tiers has curved sheet-metal wings, three feet high and four feet in diameter. The special curves are formed by attaching the sheet metal to curved plywood templates. There are plywood discs placed between each tier and at the top and bottom of the rotor, which direct the wind through the rotor. The three segments and five discs are slid onto a ten foot shaft. Each one is attached with a flange to the shaft. The rotor assembly is then mounted on bearings inside a rectangular wooden frame.

The simplest and sturdiest tower for the Savonius rotor consists of a set of two permanent wooden posts, set in concrete, between which the rotor frame is placed. Each post has three guy wires. Two large bolts pass through the posts at chest level and through the rotor frame. This enables the rotor to be swung upright, as though on a hinge, for securing at the top. This method is a variation of the hinged tower used by Earthmind, a group doing valuable

research on vertical axis windmills (6).

One difficulty we have encountered in pumping water with a Savonius rotor is in tracking down a suitable pump. A diaphragm pump, as suggested by the Brace Research Institute, will not lift more than six feet. Centrifugal pumps invariably require very high RPM's. Rotary impeller pumps generally are quite hard to turn. Reciprocal pumps require some sort of mechanical linkage such as gears, cranks, V-belts, etc., which begin to get complicated. When one's water source is not directly below the windmill, the situation is even more difficult.

Our current plan is to have the Savonius rotor turn a small air compressor, to pipe air to the well, and to pump water with compressed air. This strategy solves the problems of variable speed and power input, freezing of pumps and pipes, and transmission of power from one place to another. While compressing air is somewhat less efficient than other means of energy transmission and storage, the simplicity and durability of the mechanism is an advantage. It is, however, no small matter to find a compressed air-driven water pump. We are aware of only one commercial model (7), which is excellent, but expensive.

We are working on a pump which is less efficient but much cheaper and combines the merits of a diaphragm pump with a simple air-control device. The pump design evolved from three sources; the commercial diaphragm pumps (8), C. J. Swer's solar pump (9), and the Stauffer's compressed air pump (7). In operation, compressed air forces the rubber diaphragm down simultaneously forcing water out. Eventually the pressure on the diaphragm pulls the exhaust plug from the exhaust opening, letting the pressure out and allowing the diaphragm to pull in new water. When refilled, the stopper seats in the exhaust opening and the cycle repeats.

It should be mentioned here that while this pump can undoubtedly be improved, its present form lends itself well to home-scale manufacture. Interestingly enough, enameled wash basins and metal dish pans have the appropriate shape and wide lip for such a pump. Inner tube rubber is also suitable.

Our future work in the development of the rotor/compressor/pump system will include using compressed air for other uses, such as fish pond aeration and circulation, and investigating the benefits of compressed air storage to cope with the fluctuation of the winds.

— Earle Barnhart

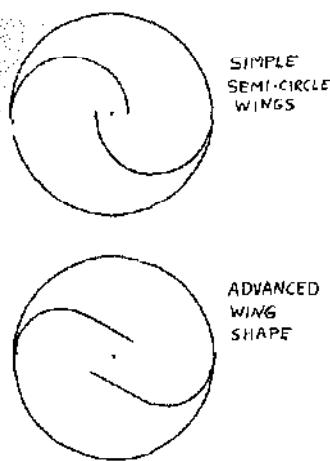

Figure 1
Simple and Advanced Shapes
for Savonius Rotor Wings.

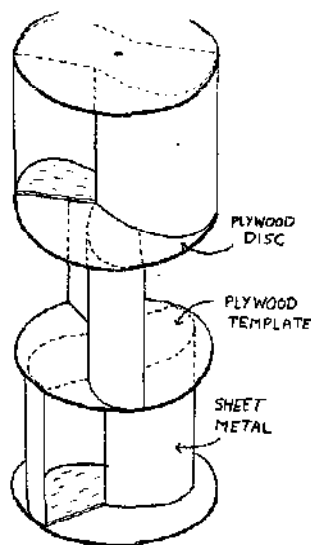

Figure 2
Three-tiered Savonius Rotor Showing
Wing Templates and 60°-60°-60° Twist.

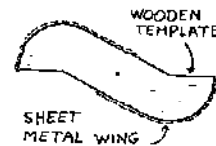

Figure 3
Use of Plywood Template to Form
Complex Curves on Savonius Wings.

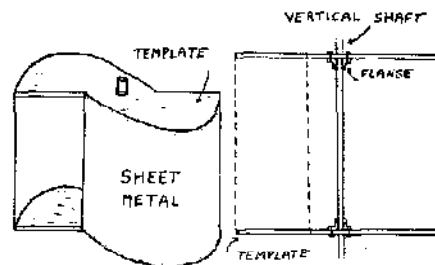

Figure 4
Savonius Wing Assembly.

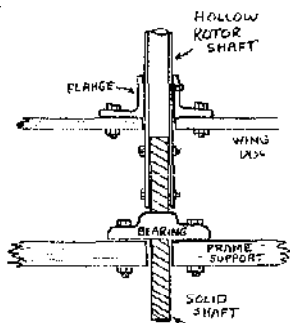

Figure 5
Details of Savonius Rotor Bottom
Bearing and Wing Attachment.

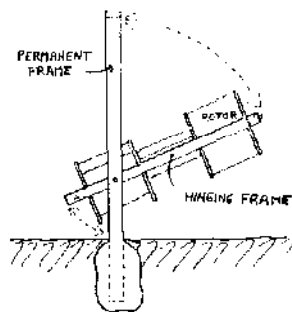

Figure 6
Savonius Rotor Tower - Permanent
Outer Frame and Hinging Inner Frame.

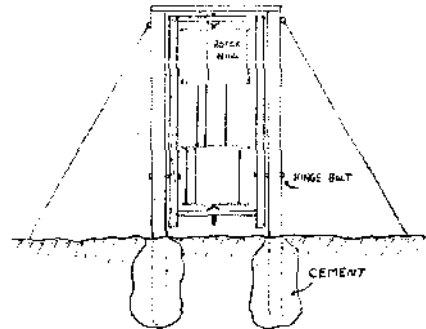
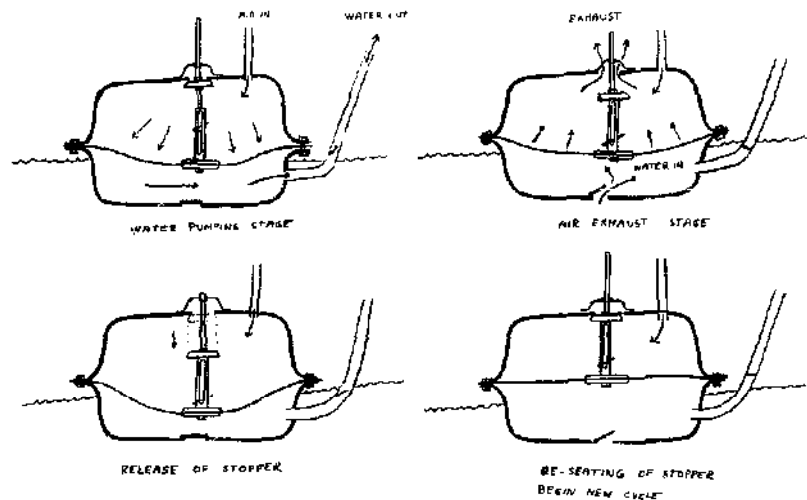
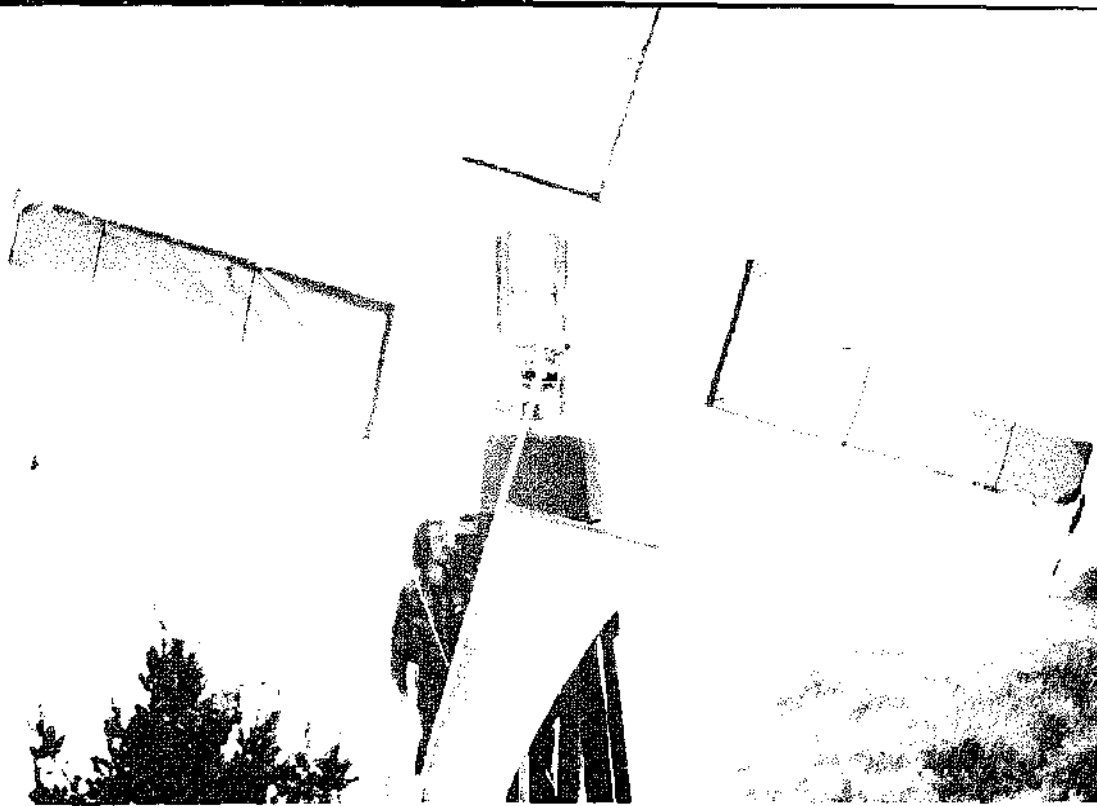

Figure 7
Savonius Rotor Tower -
Rotor is Swung into Position.



REFERENCES

1. Barnhart, E. 1973. "Savonius Rotor." *The Journal of The New Alchemists* (1): p.14
2. Bodek, A. 1973. "How to Construct a Cheap Wind Machine for Pumping Water." 15 pp. - \$1.00.
Simonds, M., and A. Bodek. 1964. "Performance Test of a Savonius Rotor." Tech. Report T-10. Both from: Brace Research Institute, MacDonald College of McGill University, St. Anne de Bellevue 800, Quebec, CANADA.
3. Savonius, Sigurd Johannes and Co. 1925. "The Wing Rotor in Theory and Practice." Norblad and Peterson, Helsingfors, FINLAND.
4. Klemin, Alexander. 1925. "The Savonius Wing Rotor." *Mechanical Engineering*, Vol. 47, No. 11: 911-912 pp.
5. Savonius, S. J. 1931. "The Savonius Rotor and its Applications." *Mechanical Engineering*, Vol. 53, No. 5: 333-338 pp.
6. Hackleman, Michael. 1974. "Wind and Windspinners." Earthmind, 2651 O'Joesel Drive, Saugus, California 91350 - \$7.50.
7. Stauffer's Machine Shop Pump Division, R. D. No. 3, Ephrata, Pennsylvania 17522. Air-operated mesh-water pumps; drilled-well and open-well pumps. \$257.50 - \$339.50 (April, 1975).
8. Edson Corporation, 460 Industrial Park Road, New Bedford, Massachusetts. Hand-operated and power-driven diaphragm pumps.
9. Swet, C. J., and H. G. Fox. 1973. "Low Head Solar Water Pumping." Presented at the 8th Intersociety Energy Conversion Engineering Conference (IECEC), Philadelphia, Pennsylvania - August, 1973, 341-347 pp.



The Green Gulch Sailwing

— Tyrone Cashman

The Green Gulch sailwing windpowered irrigation pump was conceived of and implemented jointly by the Arca Foundation, the Zen Center and the New Alchemy Institute. For the Zen Center it represents the first step in the integration of wind energy into their stewardship of their valley.

In the long range, Green Gulch Farm, as a permanent agricultural/natural cycle based community, will reap increasing advantage in food and energy from the recycling of water, of human, plant and animal waste material, and a pragmatic and benign use of wind, sun and gravity-powered water flow.

The community is destined to become a model of gentle stewardship of land — receiving from it a true abundance, while under its guiding hands the soil, ponds, gardens, hillsides and total landscape become richer, more biologically diverse and more beautiful year by year.

The Green Gulch Sailwing provides irrigating water, a constant reminder of natural forces, and basic experience in wind technology for those who helped design and build it and for those who will operate and maintain it. Further wind projects for grey-water aeration, milling, winnowing, water pumping and

electrical generation will easily be incorporated by the community through the practical experience and understanding this windmill is providing.

Besides the practical and economic value of this mill, there is an aspect of equal importance and equally appreciated by the community: the mill is beautiful as it turns. The evening sun glows through its sails. It graces the valley as it responds to gentle movements of air. And it is quiet — as it must be (and few windmills are) for its location within yards of the meditation hall in a meditative community.

As a research entity in gentle technologies, New Alchemy sought two goals with this sailwing: (a) to create a wind-powered irrigation system carefully tuned to the bio-region and even to the microclimate of Green Gulch Farm and (b) to advance its research on the problems of inexpensive, durable, simple, high volume/low wind windmills — mills that can also withstand relatively high winds without human intervention.

One of the key problems in inexpensive windmill design is to design for both high and low winds. Since the energy in winds increases *by the cube* of the wind-speed, windmills that are light and large enough to

produce work in winds under 10 mph are extremely vulnerable to the exponential increases of energy in higher winds.

In designing for the Green Gulch valley, there is the advantage that, for three seasons of the year — spring, summer and fall — when most of the irrigating must be done, the winds are quite tame. Rarely will a wind come up that is over 20 mph. In winter, storms can be expected with winds to gale force and beyond.

The average recorded wind in the lowest wind season — April/May — at the windmill site was 4.44 mph in 1977. The design of a mill which will do regular and significant work in a 4 mph wind regime and still weather winds of 30 to 35 mph without human attention was our goal.

A windmill that is available commercially, such as the American multi-blade sold by Aermotor, Dempster, is the end product of a design that ceased evolving significantly in the 1930's. It begins pumping in light winds due to a 3-to-1 down-stepping gear ratio, giving it added torque to overcome start-up inertia, static head and friction in light winds; but it pays for that torque with a loss of 2/3 potential volume of flow, extra friction in the gear mechanism and considerable expense intrinsic to the production of strong, slow-speed gear wheels.

The rotor, which is made of rigid metal blades, must be turned out of the wind when winds are too high — and extra mechanisms are provided to perform this function either automatically or manually. The construction is of metal.

The advantage of the American multi-blade design is that it is proven to be safe and reliable, requiring little operator attention. These mills are especially well-designed for remote stock-watering operations.

We priced the largest Dempster, which has a rotor diameter of 14 feet and an appropriate tower for our site, and found that the combination turned out to be over \$4,000, not including the pump.

The windmills found on the shores of the Mediterranean are designed for the constant, relatively light winds of their region. Cloth is used for sails and wooden spars, windshafts and even wooden bearings are traditional. These mills are inexpensive and responsive to light winds, but their sails must be furled or removed before a storm or if the mill is to be left unattended for a long period of time. Such constant watching and attention are not to be expected of the American farmer or horticulturist.

For several years, New Alchemy has been engaged in the development of simple, low-cost sailing water-pumping windmills which would be adaptable to diverse wind regimes and which would combine the best qualities of the American multi-blade and Mediterranean mills. The Green Gulch Sailing may not be that model yet, but it is, on several fronts, a large step

forward in the improvement and refinement of the basic design.

Parallel to the development of New Alchemy Sailing, a small group of missionaries in Omo, Ethiopia, have been developing and testing a variety of sailing mills for low-level irrigation pumping. The results of their experiments are recorded in a book by Peter Fraenkel of the Intermediate Technology Development Group in London: *Food from Windmills* (London: ITDG, Parnell House, 25 Wilton Rd., SW1V 1JS, 1975). These practical experimenters found some of the New Alchemy ideas and data useful in their work and, in turn, some of their results have been helpful in the design of the Green Gulch Sailing.

DESIGN AND CONSTRUCTION

A. The Site

The mill site was chosen by several criteria:

1. Close enough to the water source that the pump at the base of the mill could be no more than approximately 10 feet above the water surface in all seasons. At this distance a pump which operates frequently enough to keep its leather piston rings moist will not need to be primed. This is essential for a windmill pump which of necessity stops operating for periods of time when the wind dies entirely.
2. Good access to the wind. The site is one hundred yards from the nearest obstruction of its own height, a row of windbreak trees, and is directly behind a gap in the trees in the direction of the prevailing winds.
3. Enough space around the tower base to allow additional devices (air-compressor, winnower, thresher, grinder, etc.) to be connected to the present pump shaft should need dictate and appropriate devices be found or built.
4. The mill is located within sight of the office, the dwelling area and the fields. It is not wise to locate a newly designed windmill out of sight. Young people are tempted to climb it while it is working, if no one is looking. Also, if any aspect of the mill needs attention, it can receive it before the mill damages itself.
5. The site is out of the way of walking and gardening traffic.

B. Tower

The tower is designed to use low cost, light weight materials, pine 2 x 4's. Tower strength is achieved by spreading weight and windpressure over eight legs. The tower foundation is eight recycled redwood railroad ties, painted with creosote and buried three to four feet in the clay soil. Strength and convenience in mill maintenance is provided by two circular platforms dividing the tower in thirds. Rigidity is ob-

tained by cross-bracing with 1 x 3's on the lower bays and by simply doubling the 2 x 4 legs in the upper bay, which allows maximum wind passage through the tower at sail level.

The advantages of wood over metal towers are: cost, local accessibility and long-life as, with constant slight bending and vibration, wood will not fatigue, whereas metal can.

C. Turntable

DESIGN

Purpose:

1. To allow rotor, transmission and pump shaft to rotate 360° freely in the horizontal plane, in response to changes in wind direction.
2. To bear one ton of off-center load without wear or settling on the side opposite the prevailing winds.
3. To allow a minimum orifice of 2 square inches at the precise center of rotation for pump shaft to pass through.
4. To provide the chassis for all tower-top mechanisms.

CONSTRUCTION

We calculated that a free-floating rear axle from a 3/4 ton truck, when set on end, was capable of meeting all these specifications with a large margin. Such axles are available in scrap metal yards throughout this country and in many others around the world. The cheapest and probably highest quality turntable we could have used was this recycled truck axle. At the low revolutions per day of this application, there should be many years of life left in it.

Before the axle can be used for a turntable, the power shaft is removed from the axle, leaving a 3-square-inch passageway in the center for the pump shaft. The brake parts are removed and a 20-inch diameter disc of steel, 3/4 inch thick, is welded as a base for the axle to sit on. Braces underneath the wooden tower platform give added strength against lateral pressure from the wind.

Care must be taken to protect the bearings from rust through exposure to the elements. We protected the bearings with an aluminum cowling which covers the entire transmission. Another protective measure used by the Farallones Institute is to grease the bearings well with boat trailer axle grease (designed to be immersed in water) and cover the opening with the appropriate size jar lid, punctured so that the cut edges lead rain water down the pump shaft and away from the bearings.

D. Transmission

Purpose: to transfer power from rotary (wind shaft) to reciprocal (pumpshaft) motion with maximum efficiency and durability and minimum expense and complexity.

This is accomplished with a 14-inch diameter steel disc, 1/2 inch in thickness, welded to a 2-inch sleeve, machined with a keyway and drilled for a hardened bolt. This disc and sleeve fit over the end of a 2-inch cold-rolled steel bar, 32 inches long, which functions as the wind shaft, bearing all the weight of the rotor and transferring the motion of the rotor to the disc.

The disc is drilled with three 1-inch holes, to any of which a 14-inch long, 3/4 inch diameter cold-rolled steel bar, fitted with rod end bearings on either end, can be attached. This connecting rod is further encased in a section of galvanized steel pipe for greater strength.

The connecting rod attaches to the vertical pump shaft at a junction point comprised of a steel box welded of 3/4-inch plate with two industrial castors welded to each side. These provide a rolling lateral bracing which forces the side-to-side motion of the disc and connecting rod to be translated into pure vertical motion. The castors run in the pathways of steel channels welded to the I beam base.

The transmission and turntable are designed and built for great strength and durability — yet simply enough for someone with welding ability to construct.

E. Rotor

DESIGN

1. The rotor was designed to function downwind from the tower without a tail or rudder. This saves weight and expense, since a tail capable of keeping a 20-foot diameter rotor facing the wind must be very long and large. In addition, sails which are able to stretch back away from the wind during gusts are in danger of rubbing against the tower and catching or snagging when winds are strong. If the rotor is downwind from the tower, the stronger the wind, the further from the tower the sails stretch.

2. To overcome the disadvantage, relative to an American multi-blade, of one-to-one gear ratio in extremely light start-up winds, the rotor was made larger. Very little is added to the expense of a sailing rotor by extending the masts, for example, from seven to ten feet. However, since the area of a disc is quadrupled when the diameter is doubled, the increase of wind energy available to a 20-foot rotor is double that of a 14-foot rotor. This increment of wind energy is further augmented by the increase in mechanical advantage of a 10-foot lever arm over a 7-foot arm. The expense, complexity and weight of a gearbox is thus eliminated.

3. This sailing rotor is designed for both low and high winds:

a. *Design for low winds*

Large diameter rotor.

Four sails, each sail with wind-catching area of 21 square feet.

The choice to spread 84 square feet of sail, but not more, was made when the ideal solidity factors for slow speed water pumpers were balanced against the need to limit dangerous levels of drag in high winds. The experience of the research team in Omo, Ethiopia, that the coefficient of power (overall system efficiency) is more a function of windspeed than of number of sails deployed was also a consideration.

More experimentation needs to be done on best tip speed ratios and solidity factors for sailing windmills. The season-by-season functioning of this mill and testing of different pumping and air-compressing tasks will help in the further refinement of design.

b. *Design for high winds*

The primary design feature of this low-wind-sensitive, moderate-solidity sailing to withstand the exponential increases in energy in high winds is the flexible shock cord sheet connecting the outboard corner of the sail root to the successive mast. The shock cord brings the whole sail (from root to tip) into tension and, in

combination with the snout cord and fiberglass batten sewn into the sail root, creates the correct airfoil curve of the sail.

The second function of the shock cord is to allow the sail to stretch back out of the wind when a sudden large gust hits it, and to bend back spilling the majority of the energy it is receiving in winds above 20 mpb. The wind-spilling ability does not interfere with the regular pumping action of the mill — since, no matter how far downwind the sail is stretched by the wind, it always retains enough energy to pump at an efficient rate.

The second design factor allowing the sailing to withstand high winds is the fact that cloth sails are flexible and can be reefed (a five-minute operation) during stormy seasons. When reefed, approximately three square feet of sail remains deployed at the mast tips. In this condition, the mill will weather gale force winds and continue pumping the whole time.

A third factor of design for high winds is the ability to set the tips of the sails at an angle that is aerodynamically inefficient, thus creating luffing of the sail tips while the roots are being driven before the wind. The net effect of this precautionary technique is to prevent the rotor from overspeeding in high winds, exceeding tolerable centrifugal forces as well as tolerable stroke rate of the pump.

4. The rotor masts are coned downwind by wire-rope stays. The purpose of coning is to create extra rigidity in the mast. Coning is done downwind so that the effect of the pressure of the wind, which would be to bend the mast further, is counteracted by the tendency of centrifugal force to straighten it.

5. The sails are designed with 17-inch tips widening to 38-inch roots, with a catenary curve cut in the trailing edge. These proportions spread the energy of the wind relatively evenly over the length of the mast while the catenary curve prevents energy loss and noise due to vibration of the roach.

6. The tip booms are a new design worked out to provide extra torque in the light wind season by allowing a steeper than normal tip boom angle at start-up. Once the rotor is moving, the tips are designed to return automatically to the correct angle for efficient operation in motion. The final implementation of this tip design has not been accomplished as of this writing.

CONSTRUCTION

1. The masts are standard 1¼ inch, 10 foot long TV antenna masts. These were chosen for their length, low cost (\$3.75 when purchased in June, 1977, as opposed to \$37.50 for aluminum spars of adequate strength) and for the ease in obtaining replacements with uniform weight.

2. Masts are stayed, front and rear, by 1/8 inch galvanized wire rope, 7 x 19 strands (for essential flexibility). At the 2/3 point on each mast, a wire rope connects it to the preceding and succeeding masts. Thus, in every direction where stress is encountered, the mast is braced. The stays provide a combination of compressive forces causing a curved downwind cone.

3. The rotor is removable from the windshaft by four bolts. A 2-1/16 inch ID steel pipe fits as a sleeve over the 2-inch windshaft. To this are welded four 9-inch sockets 1-1/8 inch ID into which are inserted the four masts. Mast ends have brazed beads for snug fit.

4. The new tip mechanism is created from an industrial castor with wheel removed, welded to 1-1/8 inch OD water pipe which inserts into the mast end — and welded as a T to a piece of light conduit to form tip boom and tip angle control weight mount. The tip boom rotates 360° on the castor double bearings when the sail is not lashed to it. It can be set manually at a given angle by inserting a pin, or left to work automatically by the action of the weight.

5. Sails are made of 5.4-ounce dyed Dacron^(R) polyester cloth with Dacron^(R) cord sewn into the trailing edge for strength and rigidity. Sail is lashed to the mast by Dacron^(R) cord with flexible tubing inserts where the cord passes over the sharp edge of a grommet.

F. Pump

DESIGN

Purpose: to receive energy in the form, intensity and speed a 20-foot sailing delivers and to translate that energy into the movement of water to a high head.

Low speed demands a positive displacement pump. Centrifugal pumps require on the order of 1,000 rpm for efficient functioning.

Reciprocal action demands either a diaphragm or piston pump.

High head eliminates diaphragm pump. It has too many interior square inches for a head that produces 75 pounds per square inch.

A piston pump is ideally adapted to the vertical motion and length of stroke that a windmill can be made to deliver.

Experimentation in Omo, Ethiopia, concluded that two single acting, commercial windmill piston pumps, operating on a lever arm such that one was voiding while the other was filling and vice versa, increase the volume of flow a windmill can produce by virtually 100 per cent. They discovered that a mill is not significantly slowed when forced to pump on the down stroke as well as the up. We were not able to discover a commercial pump manufacturer who made a double-acting pump adapted to a windmill, so we decided to build our own. In the ITDG report on the Ethiopian research, a design is offered for a double-acting pump which, at the time of the report, had not been built. The pump for the Green Gulch Sailing was built from that design. In initial tests the pump has proved very well adapted to the windmill. Further testing and shake-down must still be made.

An added advantage was seen immediately in the double-acting pump: the outflow of water is smooth, with very little pulsing. This minimizes the danger common to reciprocal pumps used for high heads, in that they are subject to return shock waves from their own pulses, causing strain and sometimes damage. This is called the "water hammer effect."

The pump is designed with a 2-inch bore. This size was determined by calculations of the back pressure on the piston head due to a head of water eighty feet high. Although the mill was originally intended to pump fifty-two feet above the pond level and, in winter time, eighty feet to the large reservoirs, experience has made us hope that it can pump a head one hundred-fifty feet. If so, we shall be able to use windmill-pumped water in the irrigation sprinkler system which needs 75 psi, as well as the drip-irrigation system which uses only 15 psi.

Since we have three settings for stroke length on the crank disc, 5 inches, 8 inches and 12 inches, a bore of 2 inches may turn out to be right for such high pressures. A head of one hundred-fifty feet, creating 75 psi of static pressure on the face of the piston which is 3.14 square inches, is resisting the piston's motion with 235 pounds of force, not considering friction and inertia.

From testing so far we have no doubts that the mill will pump to the fifty-two-foot holding tank and the eighty-foot reservoirs as designed. In all likelihood, we shall be able to set stroke length for higher volume in winds of the 10 mph range.

CONSTRUCTION

The pump was built from standard parts and pieces available in plumbing and pump-and-well shops. The barrel is a 16-inch section of 2-inch diameter PVC water pipe. Male adapters are glued to this, top and bottom, and screwed into galvanized iron T's at each end. Two 1-inch galvanized pipes with in-line check valves are connected to the T's at each end.

The sucker rod passes through a packing gland which prevents water, when under pressure in the upward direction, from leaking. The piston is equipped with two cupped leathers — one facing upward and one down.

With this design it is possible to disconnect one entry way into the pump so that it pumps on only one-half of its total stroke — and in place of the half stroke — connect another device, such as an air-compressing bellows for grey-water aeration.

This windmill is the most advanced of the New Alchemy sailwings on several counts:

1. It utilizes a far less expensive turntable of a quality equal to the 10-inch ID turntable bearing used on all recent NAI mills.
2. By the addition of a connecting rod, channels and rollers, the pump shaft runs vertically true throughout its length. This allows the shaft to be guided without significant friction and enables the mill to deliver full power on the compression stroke, a necessary condition for the use of a double-acting pump.

The connecting rod apparatus also makes possible greatly increased length of stroke — which allows high volume from a narrow bore pump.

3. The tower is designed with bowed cross braces under compressive load and a second platform. These eliminate the need for the interior guy wires. Tower work is thus more convenient.

4. Power in low winds is increased by the addition of one mast (four instead of three) and by a considerable increase in sail area for each sail.

5. Sail design is improved:

- By the use of 5.4-ounce Dacron^(R) sails instead of 3.8-ounce, which should increase the life of the sail.
- Instead of a root boom, as on earlier NAI mills, or a simple shock cord as on the most recent one, the Green Gulch Sailwing has a fiberglass batten sewn into the root edge of the sail. The shock cord is connected directly to this and to the sail, and an additional cord leading out to the snout of the rotor from this point holds the sail root permanently at 22° (except when high winds increase the angle) and keeps the batten bowed to create a correct airfoil in faint breezes.
- A catenary curve is reintroduced (early NAI sailwings had it) and a firming Dacron^(R) cord is sewn into the trailing edge.

6. A tip boom mechanism was designed for the New Alchemy Sailwing three years ago, which was to allow the tips a steep pitch out of the plane of the disc for increased start-up torque, then would, as centrifugal force increased, move the tip into the wind for best operating angle. The mechanism was not reliable as constructed, although the concept may not have been faulty. In addition, it was found that in the brisk and erratic winds of Cape Cod a wind-spilling tip mechanism was of greater use than an efficient tip angle so the mechanism was turned backwards to increase the angle out of the plane of the disc with increased speed. However, this mechanism was, in all events, too complex.

The gyroscopically-controlled tip booms, designed for the Green Gulch Sailwing, could prove to be an advance. They are simpler in concept and design, with only one moving part. Final experimental determination of the correct weight for the tip and construction of the weight-mounting device were not achieved as of this writing. This was simply due to the absence of windmill personnel for the first month after initial testing was to have begun. It was not possible to determine the correct weight for the gyroscopic lever without actual tests on the machine. Experiments with a small-scale model of the tip-boom mechanism were successful.

The tip booms as constructed can also be set manually at various angles, either for greatest efficiency and power or for different amounts of drag to prevent overspeeding.

7. With the introduction of the four-masted rotor, it becomes possible to reinforce each mast laterally by connecting it to the preceding and succeeding masts with 1/8-inch wire rope at a point 2/3 mast length from the root.

8. The double-acting pump is an improvement over all pumps New Alchemy had tried with the sailwing up to the spring of 1977. It allows high-head pumping with low back pressure for start-up and allows a range of volumes per stroke from 0.14 gallons to 0.32 gallons. It is tailored to the kind of power this sailwing produces both in form and intensity. It is specifically designed for high-head pumping.

Due to absence of personnel after the completion of the windmill construction, only minimal testing has been done. It was discovered that, with an 8-inch stroke, pumping nine feet up from the pond and directly out into the squash patch at the base of the tower, the mill began pumping in 6 mph winds and continued pumping in an average of 3 mph. It need not be said that this is an extraordinarily light wind for the performing of any useful work.

Testing of revolutions per minute on two occasions has shown that, with a moderate load (12-inch stroke pumping 35 feet above the pond) the tip speed ratio was 3.6 and did not change as the windspeed changed. Tip speed ratio is the ratio of the speed of the wing tips to the speed of the wind. In this case, the tips were travelling 3.6 times faster than the wind. This is a somewhat higher ratio than normal for a water pumper, but such speed is a disadvantage only when it translates into too little torque for light wind start-ups - or when it sends the mill into overspeed in high winds. With the aerodynamic brake (tips set at inefficient angle) and shock cord spilling of excess wind, the mill should prove to be protected against overspeed in winds up to 40 mph. As for starting torque, we have already seen that it is excellent.

It is to be expected that, when the mill is pumping up 50, 80 or even 150 feet, the tip speed ratio will be reduced to normal levels, between 2 and 3. Tested tip speed ratio with no load (pump disconnected) was 4.7.

Informal observation in winds estimated between 40 and 50 mph reveals that the rotor rpm reaches a peak at around 55 and then *slows down* as the winds rise further. This is due to the loss of airfoil when the shock cords are significantly stretched.

A rough idea of the volumes of water flow to be expected in various winds can be had from tests with a 12-inch stroke pumping 35 feet above the water source:

Windspeed (mph)	Rotor rpm	Gallons per minute
5	24	7.68
6	30	9.60
9	42	13.44
10	48	15.36

Now it is obvious to the Green Gulch community, to its many visitors and to those who drive by on Highway 1, that the winds just above the floor of the Green Gulch valley are capable of performing useful work. The development of other practical wind devices, especially to take advantage of the stronger winds found on the hillsides and hilltops, becomes a natural step. Small mills to do single specific tasks can be designed and built wherever they are needed, providing tangible working examples of a gentle, humane and enduring technology.

The Green Gulch Sailing was designed and built by Tyrone Cashman with help from:

Kenneth Sawyer Eric Larson J. Baldwin
Barton Stone Jack Park Harry Roberts

BUDGET

As of this writing, the expenses for materials were wholly available but not all the hours of labor to the completion of the mill had been tallied.

<u>MATERIALS</u>	<u>COST</u>
Lumber for the tower	\$116.64
Windshaft bearings	75.66
Steel for transmission	92.78
Castors for pump shaft	18.28
Tip boom castors	29.82
Rod end bearings	21.26
Steel disc for crank	7.42
Parts for pump	146.28
Bolts and Loctite	3.28
Wire rope, 146 ft.	30.73
Nuts, washers, bolts	8.72
Nuts and bolts	4.86
Misc. hardware	10.51
Turnbuckles and thimbles	5.90
Paint and clamps	13.49
Tail pipe clamps (for booms)	3.18
Antisize compound	1.00
Stainless steel banding	25.02
Drill bits and files	25.61
Tower paint	15.96
Extra tower paint	15.96
Aluminum sheet for cowling	25.44
Sailcloth	68.42
Extra sailcloth	9.27
Rotor hardware	56.69
18 bobbins thread	4.77
Fiberglass battens	18.83
Dacron ^(R) Rope	1.90
Shock cords	14.36
<u>OUTSIDE PROFESSIONAL LABOR</u>	
Machining on windshaft/crank	70.00
Threading connecting rod	17.50
Pump alignment and assembly	40.00
TOTAL	\$999.54

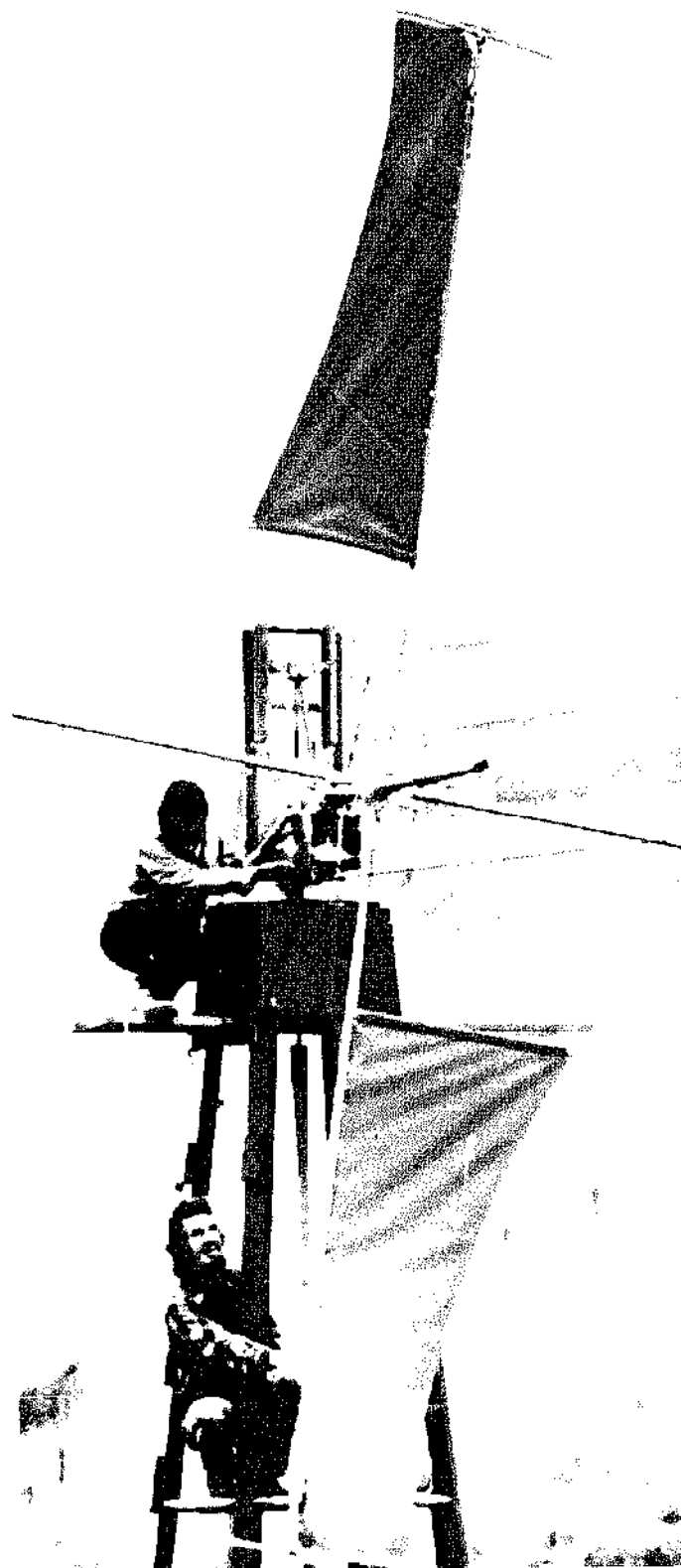



Water Pumping Windmill that Works

The best design I know is for a 26-foot high tower built by the New Alchemy Institute-East on Cape Cod and fully described in the *Journal of the New Alchemists*, No. 2. The basic structure is made from 8 lengths of 4×2 timber each 26 feet long (all timber must be treated with wood preservative). The 2 platforms are fixed to the tower by nailing down into short lengths of 4×2 bolted to the main uprights (with eye bolts, on the centre platform, to provide a fixing for the guy wires). The NAI wires run inside the tower but anchoring them outside would in my view provide a better hold. The tower is tapered to a shape given by making the top platform an octagon 28 inches across and the centre one a circle of 48 inches diameter. The main uprights are fixed at the bottom with large bolts to 8 bits of telegraph pole 6 feet long driven deep into the ground. The top half of the tower is braced with 16 40-inch lengths of 1×3 , and the bottom half with 16 58-inch lengths.

Such a tower (this one was designed for a 18-foot diameter sail machine) will give pretty good service. Bits of wood attached up the lee side will make a safe ladder, and some more pieces mounted all round about 3 feet from the top will give an easy toe-hold for working on the machine. If you want even more strength (and who doesn't?) the price of a third platform will be miniscule and help out of all proportion to its cost.

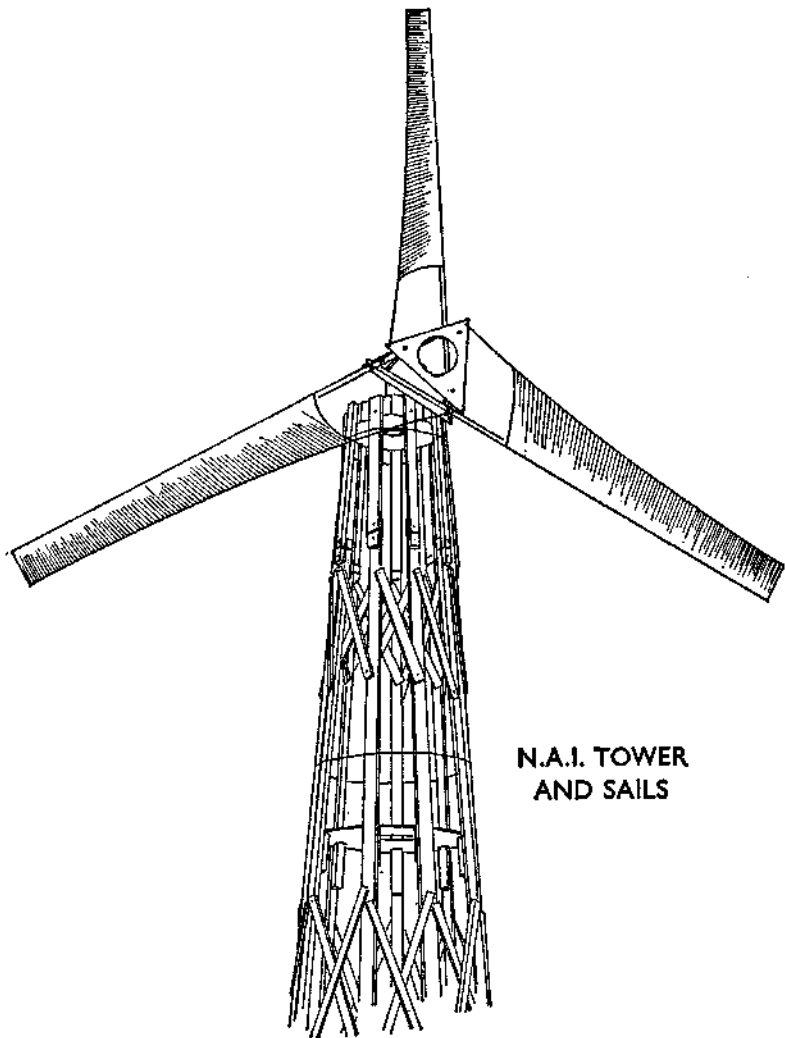

**N.A.I. TOWER
AND SAILS**



Photo by Alan L. Pearlman

This windmill consists of three cloth sails attached to three tubular steel masts which are fastened to a triangular plywood hub. The center of the hub is bolted to the end of an automobile crankshaft which spins in bearings mounted on top of a steel ball-bearing turntable. The bearing turntable unit, which allows the windmill to rotate so that the sails are always perpendicular to the wind, is mounted at the top of an eight-legged tower which is firmly guyed and braced. A piston rod connected to the crankshaft transfers power through a reciprocating vertical steel pipe which runs from the top to the bottom of the tower where it operates a high capacity piston-type water pump.

The tower legs are bolted at the base to eight telephone pole sections which are firmly buried in the ground to prevent the tower from blowing over in heavy winds. This windmill is designed to remain operational and to withstand storm conditions. Ideally the cloth sails should be removed if severe wind conditions are anticipated. Our windmill was built to supply circulating water to a series of twenty experimental aquaculture ponds. It was required that the water in each pool be replaced once each day. Water pumping trials showed a yield of 250 gallons per hour in a 6 mph wind with 18' diameter blades applying power to a 3" diameter pump through a 3 1/2" stroke.

$$\frac{7.481 \text{ gallons/ft}^3}{250 \text{ gph}} \times 7.5 \text{ g/ft}^3 = 33.3 \text{ ft}^3/\text{hr}$$

$$33.3 \text{ ft}^3/\text{hr} \times 8 \text{ hr} = 266.4 \text{ ft}^3 \text{ in } 8 \text{ hr.}$$

This figure is lower than the calculated pumping capacity of the windmill.

Because of this we recommend that a crankshaft with a greater stroke or a pump of a larger diameter piston be used. A new mill that we have just completed uses 2 No. 350 cast iron pumps mounted in tandem (Mid-West Well Supply Co., Huntley, Illinois).

Parts

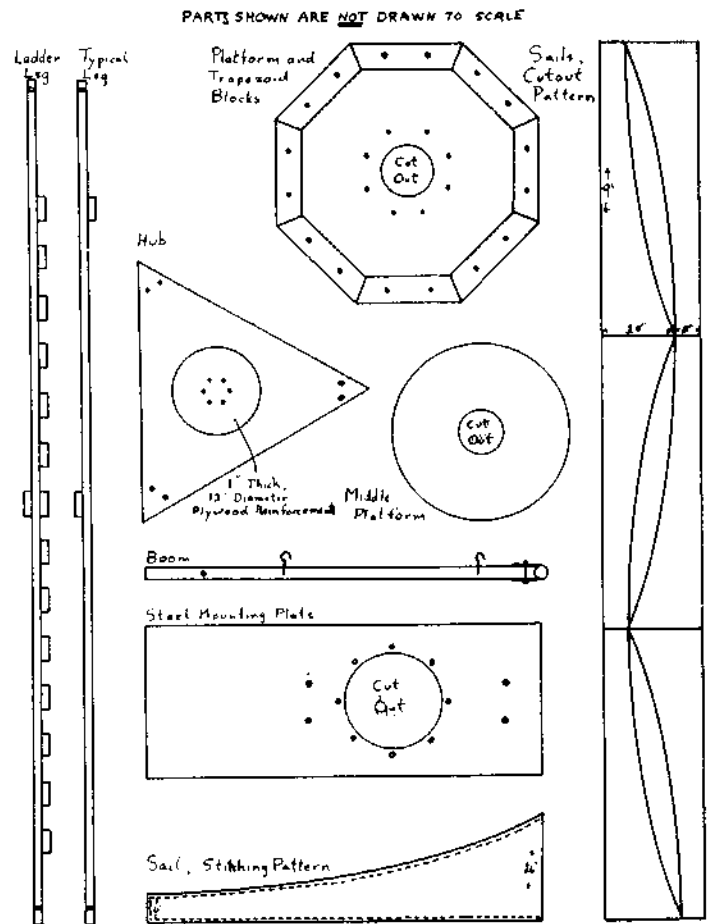
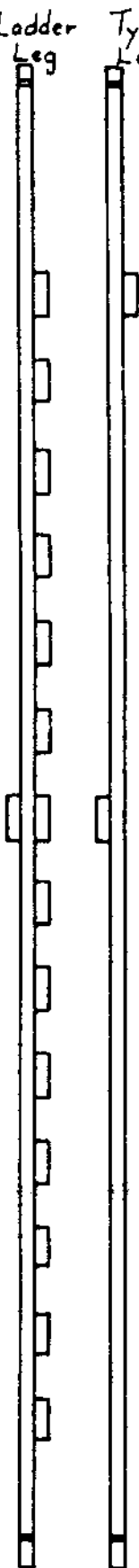

Photo by Alan L. Pearlman

Parts

PARTS SHOWN ARE NOT DRAWN TO SCALE

Ladder Leg
Typical Leg



Platform and
Trapezoid
Blocks

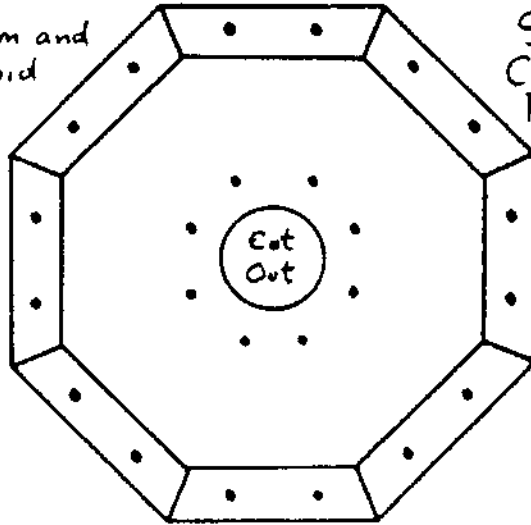

Sails,
Cutout
Pattern

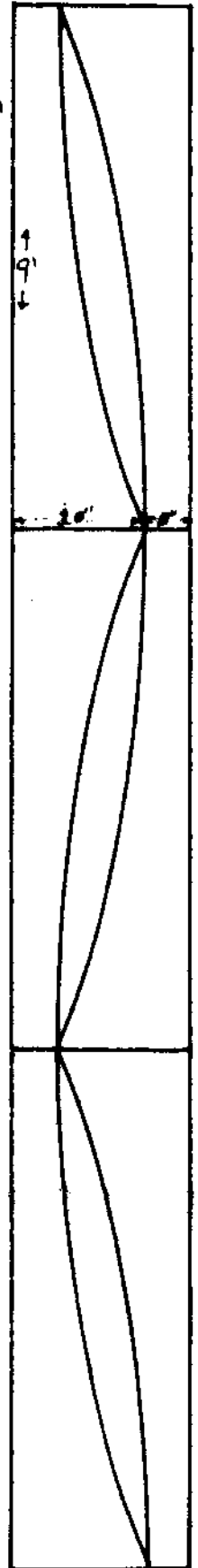

Hub

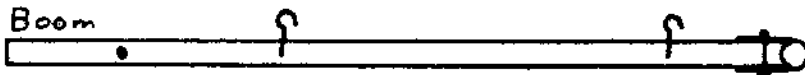
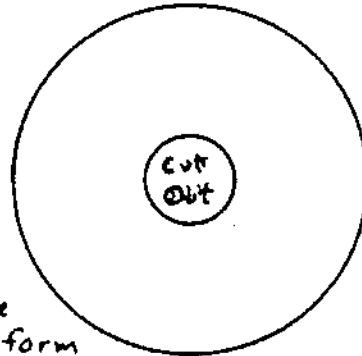
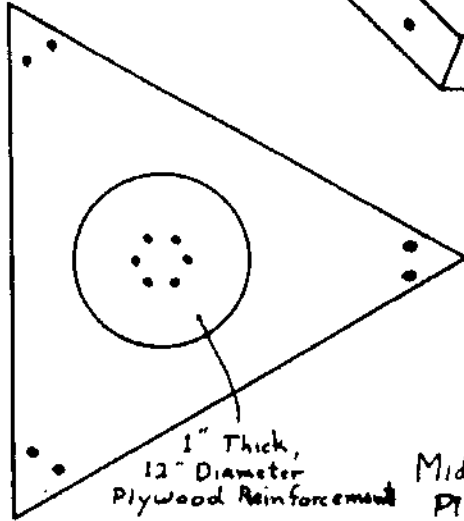

Steel Mounting Plate

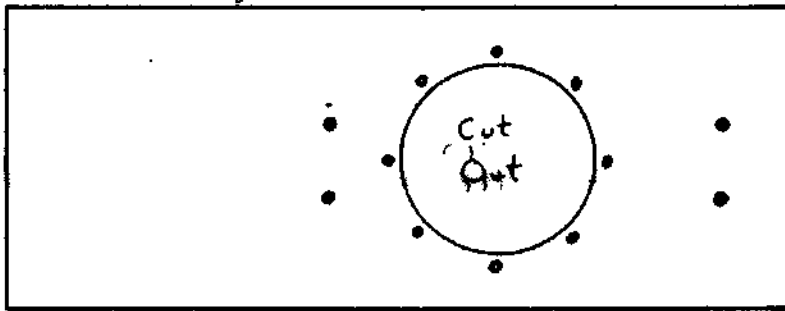

Sail, Stitching Pattern

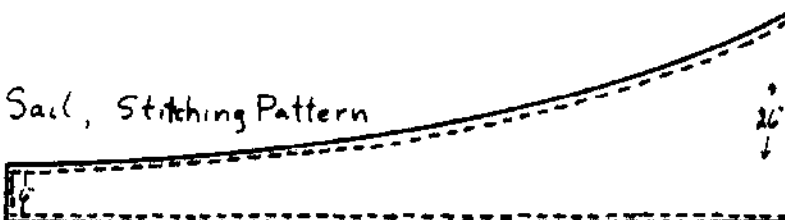

Cutout and Stitching Pattern for Sails

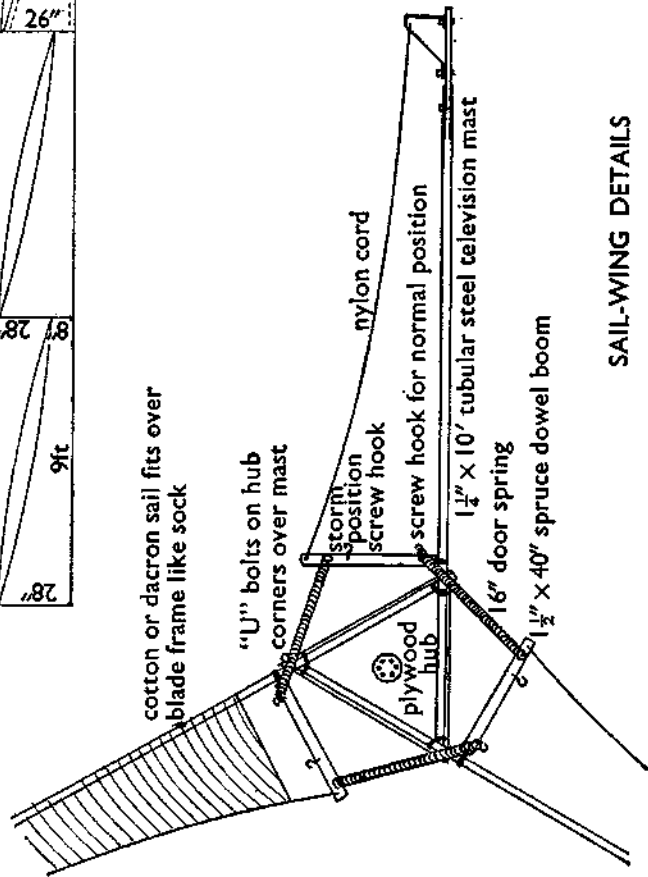

SAIL-WING DETAILS

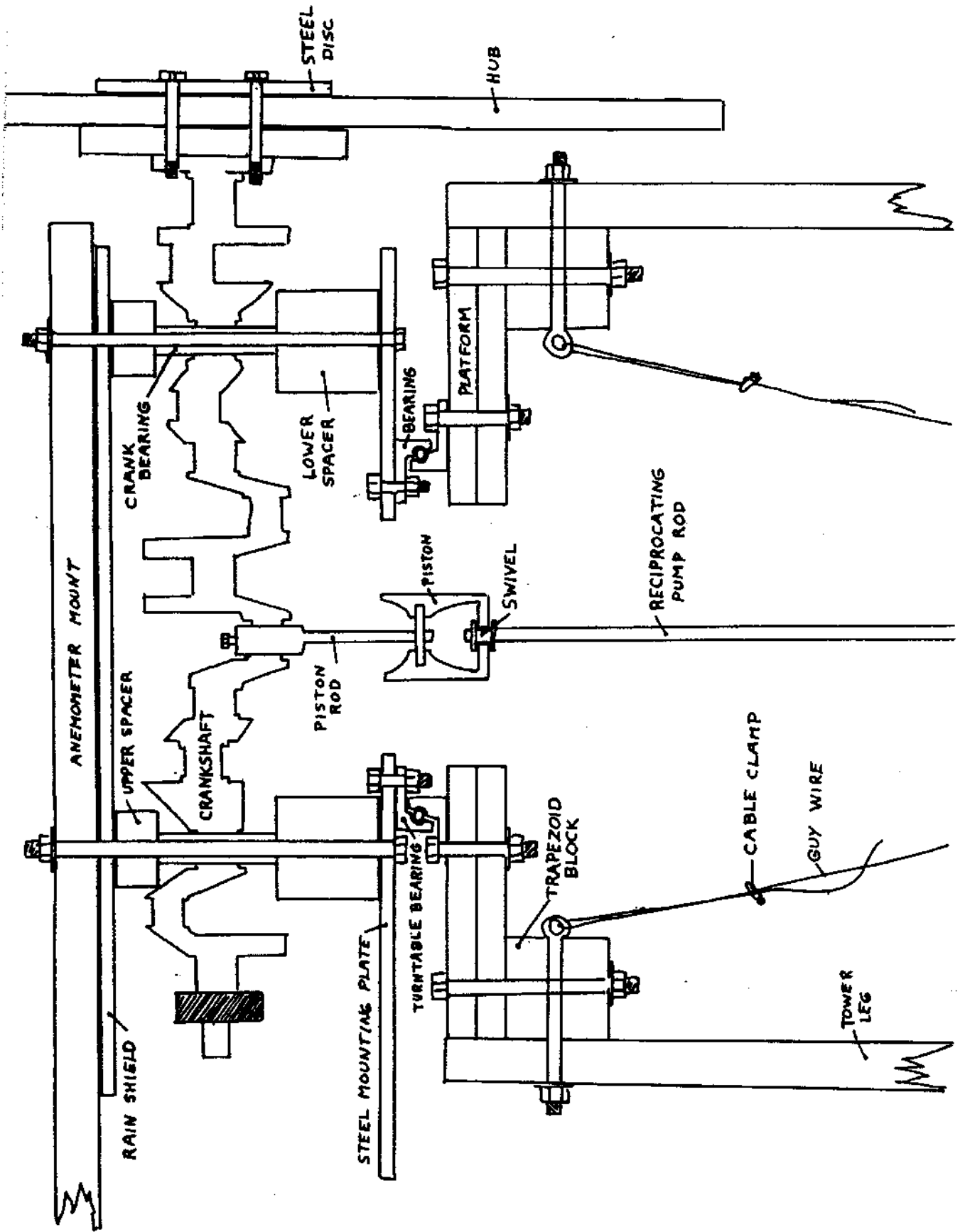

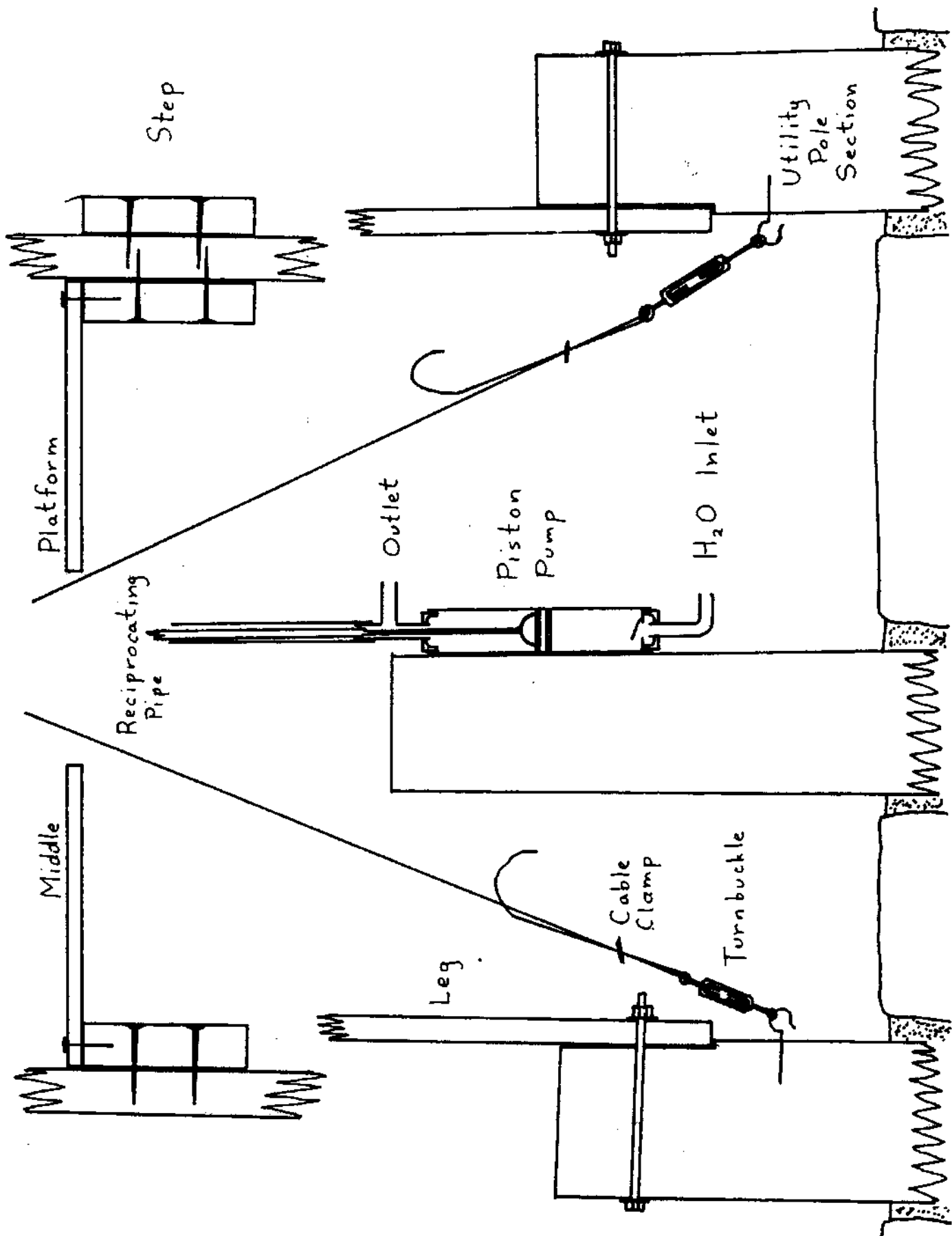

Step

Utility Pole Section

Platform

Outlet

Piston Pump

H₂O Inlet

Reciprocating Pipe

Middle

Leg

Cable Clamp

Turnbuckle

Materials in Order of Assembly:

BASE

**8 - 6' sections utility pole (or railroad ties), concrete
optional depending on hole depth**

**8 - 12" x ½" galvanized machine bolts, 8 nuts,
16 washers**

**8 heavy galvanized screw hooks to secure turnbuckles
to base**

TOWER AND TOP PLATFORM

8 - 26' x 2" x 4" spruce for tower legs

8 - 8" pieces 2" x 4" spruce to secure middle platform to inside of legs

16 - 8" pieces 2" x 4" spruce for ladder steps on outside of one leg

8 - 8" pieces 2" x 4" spruce for foot holds around top of tower

½ gross 2½" No. 10 galvanized wood screws

2 - 1" thick, 28" wide plywood octagons for top platform

1 - 10' x 3½" x 3½" spruce for making 8 wooden trapezoid blocks to secure platform to legs

16 - 7" x ½" galvanized machine bolts, 16 nuts, 32 washers, to secure trapezoid blocks to platform

8 - 6" x ½" galvanized eye bolts, 8 nuts, 16 washers, to secure top of tower legs to trapezoid blocks and to provide attachment for top of guy wires

16 - 27' lengths of t-v antennae guy wire for internal guying of tower

32 cable clamps to form loops at ends of guy wires

Several strong persons and 100' strong rope required to set tower in place, gin pole helpful

1 - 48" diameter ½" plywood disc for middle platform

16 guy wire turnbuckles

16 - 56" pieces 1" x 3" spruce for lower bracing of tower

1 - 8' piece ½" nylon rope with eye splices and safety clips (for safety line)

At least one capable person who is not afraid of heights

16 - 40" pieces 1" x 3" spruce for upper bracing of tower

1 gross 12 penny galvanized screw nails to fasten bracing to tower legs

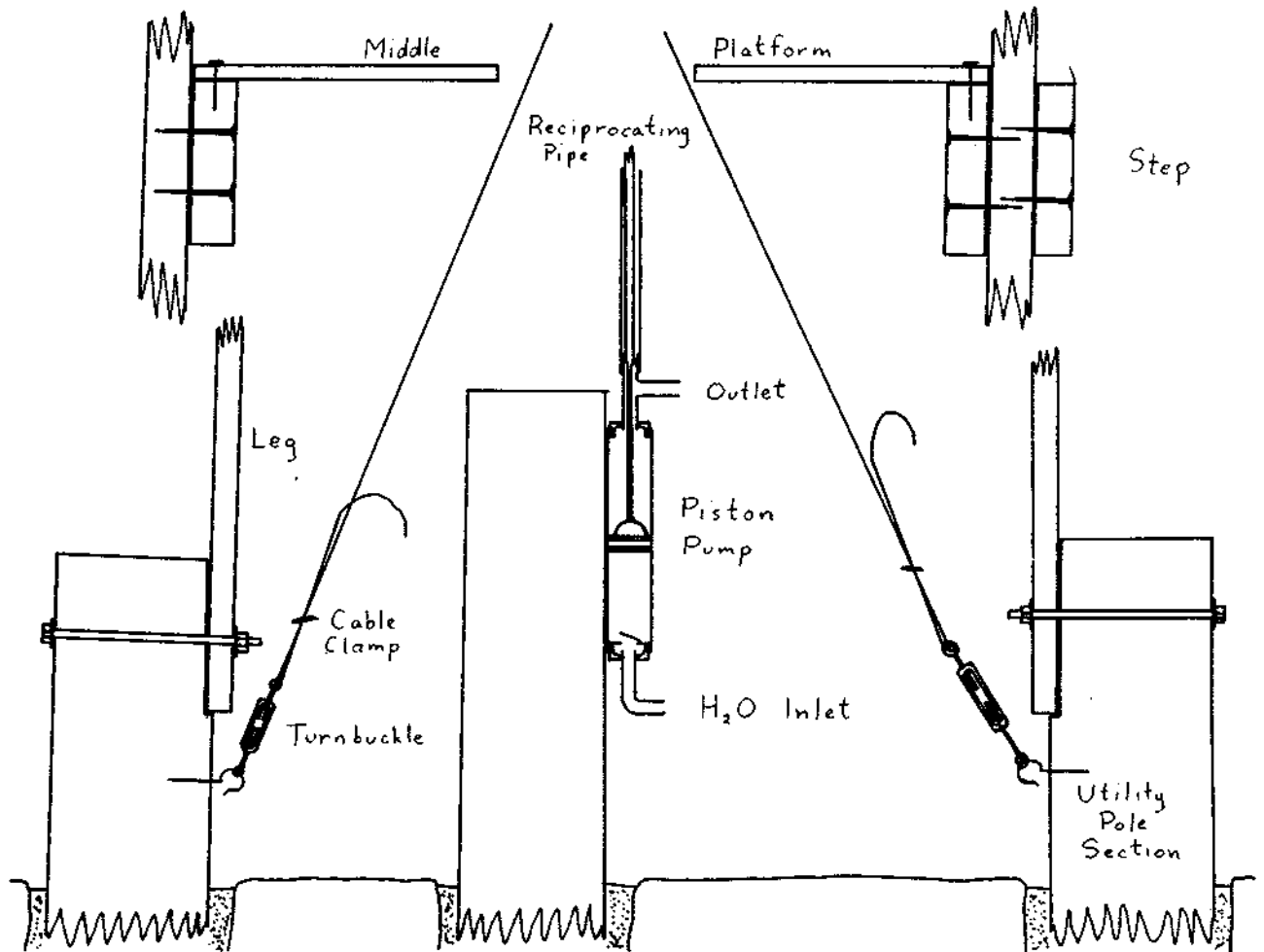
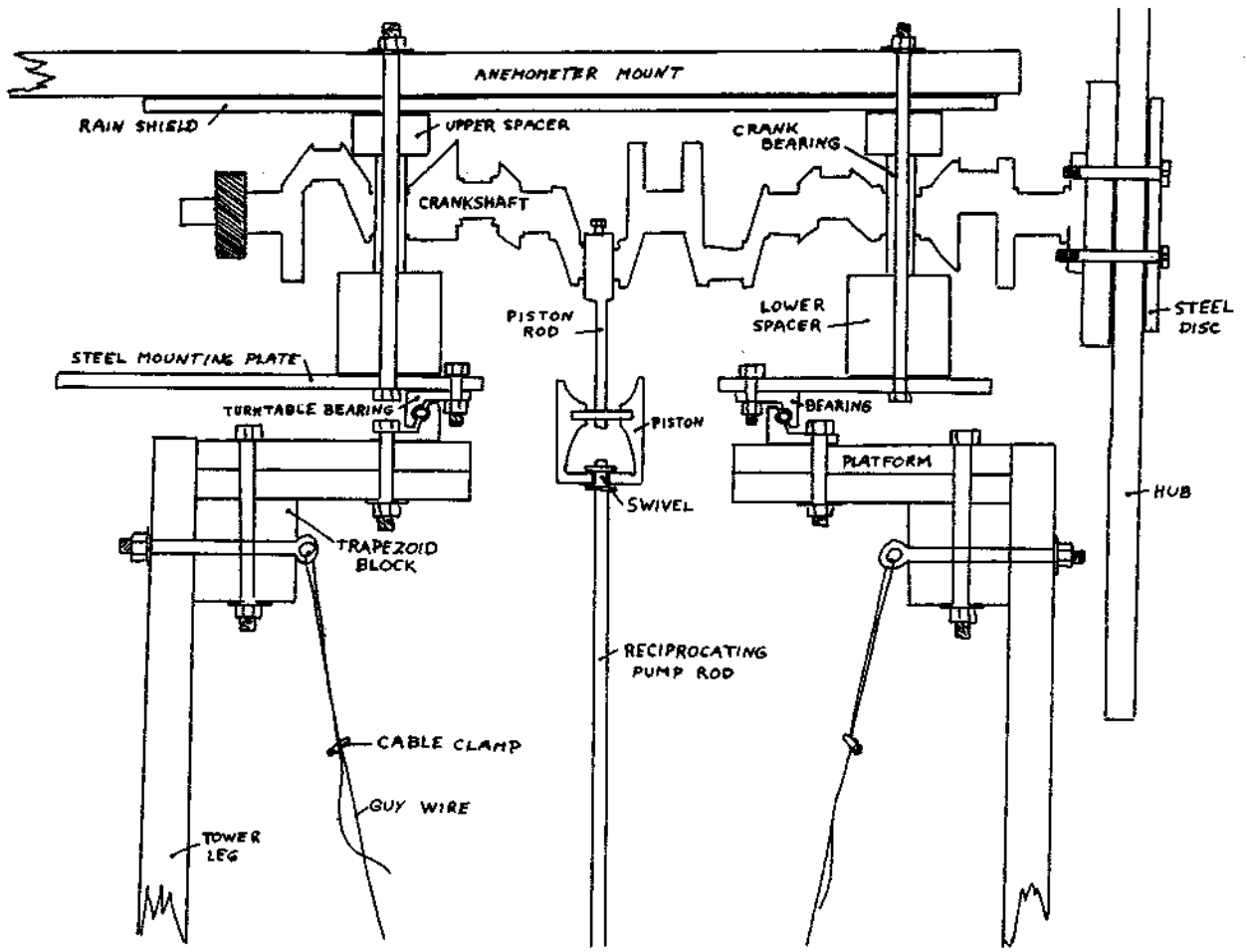

TURNTABLE AND DRIVELINE UNIT

- 1 - Model No. M4-12P4 series 1000 Econotrak bearing (9" inside diameter) from Rotek Inc., 220 West Main Street, Ravenna, Ohio 44266 (about \$129.00) with 6 holes (½" diameter) bored equidistantly in both top and bottom bearing ring segments**
- 1 - 36" x 14" x ½" steel plate for mounting crankshaft on top of turntable bearing. A hole approximately 9" in diameter must be made in this plate through which the piston rod extends to connect with reciprocating rod**
- 6 - 1¼" x ½" galvanized machine bolts, 6 nuts, 6 spring lock washers to secure steel mounting plate to top of turntable bearing**
- 1 large stroke auto or truck crankshaft with 4 of its bearing retainers. An 8 cylinder crankshaft is preferable.**
- 2 - 6" x 3½" x 3½" spruce blocks for lower bearing spacers**
- 2 - 8" x 1½" x 3½" spruce blocks for upper spacers**
- 1 - 36" x 14" x ½" plywood for rain shield**
- 1 - 8' x 1½" x 3½" spruce for anemometer mount**
- 4 - 12" x ½" galvanized machine bolts to secure anemometer mount, rain shield, upper spacer crankshaft, bearings and lower spacer to the steel mounting plate, 4 nuts, 4 washers and 4 lock washers**
- 6 - 3" x ½" galvanized machine bolts to secure bottom of bearing to platform, 6 nuts, 6 washers, 6 spring lock washers**
- 1 piston and piston rod unit to connect crankshaft to vertically-reciprocating pipe**
- 1 - 20' length ½" galvanized pipe to connect piston at top to pump at bottom**
- 4 - ½" pipe thread screw collars and 2 - ½" inside diameter heavy polyethylene washers to secure top of pipe in hole in head of piston for swivel mount**
- 1 adaptor to connect ½" pipe threads to 3/8" machine threads on pump rod**

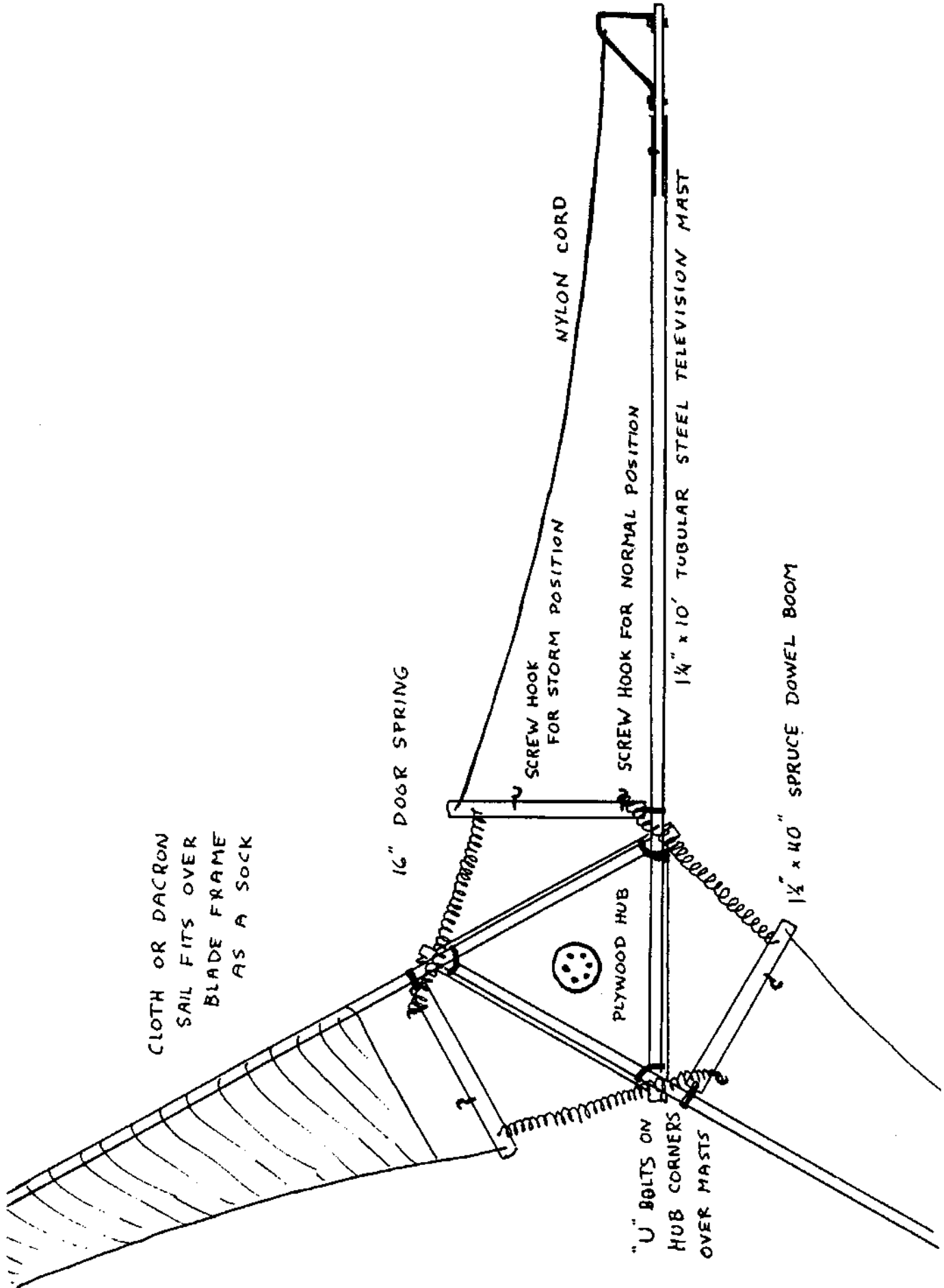

CLOTH OR DACRON
SAIL FITS OVER
BLADE FRAME
AS A SOCK

16" DOOR SPRING

NYLON CORD
SCREW HOOK
FOR STORM POSITION

SCREW HOOK FOR NORMAL POSITION

1 1/4" x 10' TUBULAR STEEL TELEVISION MAST

PLYWOOD HUB

1 1/2" x 40" SPRUCE DOWEL BOOM

"U" BOLTS ON
HUB CORNERS
OVER MASTS

HUB-BLADE UNIT

- 1 - 1" thick plywood equilateral triangle 30" on each edge for hub**
- 1 - 12" diameter 1" thick plywood circle to reinforce center of hub**
- 1 - 9" diameter ½" thick steel disc to reinforce center of hub (from hole in steel mounting plate)**
- 3 - 10' long 1¼" tubular steel t-v antennae masts for windmill masts (arms)**
- 3 - 1½" spread "U" bolts made from 3/8" threaded rod to secure masts at hub corners**
- 3 - 1½" inside diameter galvanized steel pipe sections 6" long to prevent "U" bolts from crushing masts**
- 6 wooden wedges 12" long, 1½" wide, 1" thick at fat end to adjust coning angle of masts to prevent collision with tower**
- 3 - 2' x 1" steel tubing for mast extensions**
- 3 - ¼" thick, 1" wide 21" steel straps for tip of mast extensions**
- 12 - 1½" x 3/8" machine bolts to attach steel straps to tip of mast extensions, 12 nuts, 12 spring lock washers**
- 3 - 2" cotter pins to secure mast extensions within masts**
- 3 - 32" pieces 1" spruce dowel for booms at base of masts**
- 3 - 1" x 8" medium gauge galvanized sheet metal strips to secure booms to masts**
- 3 - 16" door springs for automatic pitch control**
- 9 medium screw hooks to secure door springs to booms**
- 3 - 12' long pieces nylon cord to form trailing edges of sail blade frames**
- 9 yards muslin, cotton or dacron sail material**

PUMP UNIT

- 1 - 8' section utility pole (or railroad tie) set in ground off center of line of travel of vertically-reciprocating pipe (pump cylinder is mounted on this)**
- 1 Model No. 81 brass-lined pump cylinder No. 380-1-3021 from Demster Industries Inc., P. O. Box 848, Beatrice, Nebraska 68310 (about \$45.00), or any large diameter piston pump or Model No. 350 Shallow Well Cast Iron Cylinder from Mid-West Well Supply Co., Huntley, Illinois (about \$18.50).**
- 1 "T" joint for outlet of pump**
- 1 - 1¼" check valve for bottom of intake pipe**
- Adequate 1¼" plastic piping for inlet and outlet of water**

TOOLS NEEDED

Bit brace, chisel, cross-cut wood saw, hammer, level, open-end wrench set, paint brushes, post-hole digger, screwdrivers, sewing machine, shovel, socket wrench set, 9/16" wood bit, and wood clamps; *Optional:* electric drill (heavy duty), high speed drill set, jig saw, skill saw, and ½" steel strapping and tensioning tool from Signode Corp.

OTHER SUPPLIES NEEDED

1 gallon white exterior primer paint, 1 gallon exterior paint, 1 quart black Rust Oleum paint, Weldwood or Borden's 2-part plastic resin wood cement, all-weather farm grease, and silicone sealing compound

OPTIONAL ITEMS

1 anemometer (recording)

1 water meter

Water storage tank(s)

Most parts are available at any lumberyard, hardware store, auto junk yard and t-v supply store. Only the water pump and turntable bearing are “send away for” items. Total cost (less tools and labor) is less than \$300.00 in U. S.

Note on scrounging: It is usually cheaper and more expedient to ask persons directly responsible for the article desired; i. e., the yard foreman, truckdriver, stockboy, job foreman, etc., not the purchasing agent or factory superintendent.

— *Marcus M. Sherman*

POSTSCRIPT

Testing of the mill: Since the article was prepared we have had an opportunity to test the sailwing windmill for ruggedness and pumping ability.

The windmill, with the cotton sail blades of 18' diameter, did indeed pump 250 gallons per hour in 6 mph winds. The water was pumped up 14' from a lake below the windmill. Our calculations and direct observations indicated that our pump was considerably undersized for the windmill. A larger stroke or a larger diameter piston pump would have been desirable. Our latest sailwing windmill, with sails designed by Merrill Hall, has two pumps mounted side by side (see drawing of advanced backyard fish farm mill) and we may yet add additional pumps.

Cotton versus dacron sails: During the winter trials the cotton sails did not stand up to continuous operation through storms and high winds. We decided to try dacron sails as dacron is a much longer-lived material, holds its shape better, does not absorb water during rains and is much stronger and lighter than cotton.

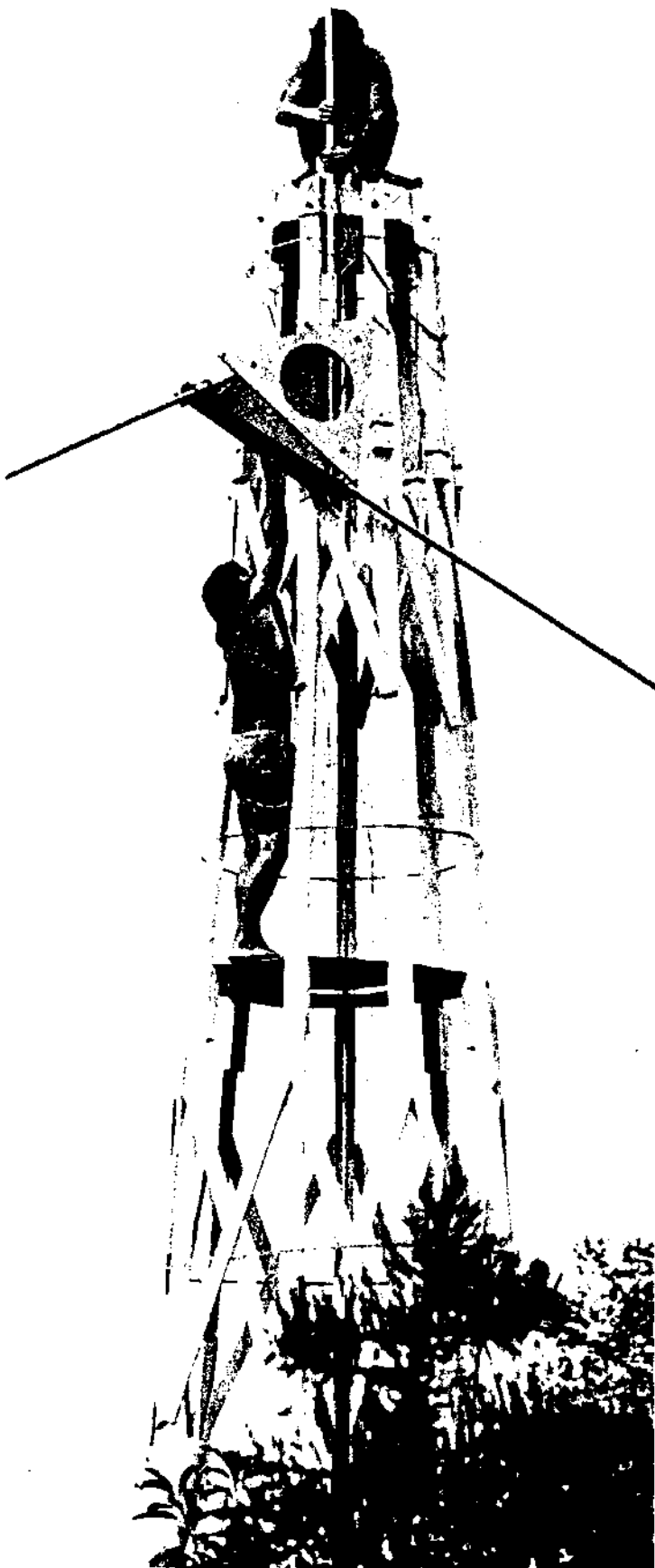

Photo by Alan L. Pearlman



Photo by Alan L. Pearlman

These are important factors when it comes to the design of large sailwings.

Merrill Hall made us a set of 3.8 oz. dacron sails to Marcus Sherman's design. From visual observations they seem to perform better than the cotton sails did. They are steadier and have a better configuration while driving in heavy winds.

It was not long before we had a chance to test the dacron sails. With the feathering springs set in their storm position (see sailing diagram) the mill came through a force nine gale (40 knots-plus winds) and continued to pump throughout the storm. The next gale arrived a few days later accompanied by freezing rain. This time we decided to leave the feathering springs in their full working position. The mill, to our great pleasure, was still pumping when the storm abated. The strong sails and Marc's spring feathering system have vindicated themselves, and since the last gale, a number of severe storms have been weathered.

Post Postscript

We have recently learned that dacron is not superior to cotton for use in tropical areas, although coloured dacron has proved more durable than white.

Problems: During high winds, bolts and screws, including those on the end of the crankshaft, shake themselves loose. We replaced the hub bolts with longer ones so that lock washers and nuts could be placed on the crankshaft side of the hub. If you plan to have your windmill operate during high winds, we advise that you do not skimp; get quality materials and build it to last a long time, perhaps even a lifetime.

The windmill as accomplice and ally: Our sailing windmill with its bright red sails has brought us an immense amount of satisfaction. Having it around makes us feel better, and there is something almost magic about working with the wind. At the bottom of the tower with the wind passing through the rigging, one is carried off to the plains of Crete and to distant shores where men first used the wind to drive their vessels and embark upon the unknown.

A Windmill in India



While other members of the New Alchemy family were deciding to spend the winter in France, Costa Rica, California and good ole wind-swept Cape Cod, I chose to return to the nine acre peanut farm of my friend Tim Heineman in South India. Tim's farm is located outside of a small village among some rolling hills near Madurai, Tamilnadu state. During my previous stay at the farm in 1971 we had talked about installing a well and a water pump near Tim's mud hut so that we would not have to haul water manually in buckets up from the stream for drinking and cooking. At that time the only supply of water was a small stream flowing through the farm that goes completely dry during the winter drought and floods during the monsoon in the spring. Tim wanted the new pumping system to be able to irrigate a one acre vegetable garden all year round in addition to watering the cattle and supplying the hut. We realized that there were many problems to overcome if we were to install an independent, cheap and reliable water supply system.

In many parts of India including Tim's farm there are adequate supplies of ground water which are unavailable to farmers during the dry season because of inadequate power sources for pumping. Three to eight horsepower diesel pumps are frequently used but are expensive to operate because of the high cost of imported oil and often must be taken out of service for costly and time-consuming repairs. Efficient five horsepower electric pumps are being used more and more as rural electrification proceeds, but only well-to-do farmers can afford to buy and maintain them. This winter in South India there was a 75% power cut to the rural areas due to heavy consumption in the cities and to overexpansion of the power grid without a corresponding increase in sup-

ply. This power shortage means that there are only four hours of electric pumping per day. This situation is expected to worsen for the next four to five years until the Indian Government begins operation of atomic power plants in South India. At the present time bullock operated pumps remain the most common and reliable source of irrigation water for subsistence farming. Water for domestic use is usually hand-lifted with a rope and bucket from open wells.

During the early 1960's the Wind Power Division of the National Aeronautical Laboratory in Bangalore, Mysore, developed, tested and produced two hundred 12-bladed fan-type windmills which demonstrate the feasibility of using wind power to pump water to South India. Several types of imported European and American multibladed windmills have also been used to harness India's abundant wind energy resources. However, due to lack of public awareness and the unavailability of simple and inexpensive devices, wind power is only occasionally exploited.

With these thoughts in mind I returned to the States for one year. While working at the New Alchemy farm on Cape Cod, Earle Barnhart and I built and tested a three-bladed cloth sail windmill which appeared to be simple and efficient enough for practical use on Tim's farm.

Cloth sails with a wooden framework have been used for hundreds of years for transforming the useful energy of the wind into labor-saving mechanical work, especially for grinding grain and pumping water. The use of windmills spread from Iran in the seventh century A. D. to coastal China where the application of the art of sailmaking significantly improved the sophistication of windmill construction. Heavy rigid wood wind-

mill blades surfaced with cloth were used increasingly throughout northwestern Europe and by the seventeenth century the Netherlands had become one of the world's richest and most industrialized nations largely as a result of extensive exploitation of windpower with ships and windmills. Cloth was a natural choice for windmill sails because of its acceptance and wide use in sailing ships. It is lightweight, easy to handle, readily and cheaply available, and most important, it forms a strong uniform surface for catching the wind when firmly supported at three or more points.

In the Mediterranean region flour-grinding and oil-pressing mills were rigged with six to twelve triangular cloth sails set on simple radial spars. A three-dimensional array of guy ropes radiating from a central spar projecting out along the axis of the main shaft, suspended the sails in position, rather than the heavy grid of wood used in the traditional Dutch-type windmills. This sailboat jib type of rigging was a significant improvement in windmill design which encouraged the spread of windmills throughout the deforested Mediterranean countries. The wind capturing area of these windmills was controlled by wrapping each cloth sail around its spar. Though requiring daily rigging adjustments and occasional replacement of tattered sails, the efficiency and simplicity of these windmills resulted in their widespread use in Rhodes, the Black Sea coast, the Aegean Islands and Greece. In Portugal their use was accompanied by the sound of whistles attached to the rigging, an audible indicator of the wind at work. In the West Indies large sailing windmills were commonly used for crushing sugar cane. Many handcrafted windmills with eight triangular jib sails are presently pumping irrigation water in the Plain of Lassithi, Crete. In Japan four-bladed jib sail windmills are used to operate reciprocating pumps which supply water to vegetable gardens. A high-speed aerodynamic two-bladed sail wing is being developed at Princeton University. Further construction simplifications may make it applicable to use in less developed countries.

A windmill with four self-adjusting cloth sails has been developed by Mr. H. Stam for rural markets in less industrialized regions. Its relatively complex design is limited because of the difficulty in connecting it to a deep well pump. Unfortunately, it cannot be manufactured by hand using local materials. Those people who are in a situation to most benefit from a windmill are also those least able to pay for it. If the critical moving parts were separately available, a small farmer could purchase the remaining materials needed and assemble the windmill in his own village using local skills and labor. This way a major portion of the money spent would remain in the village.

Upon returning to India this winter I discussed some of the problems of building a small practical windpowered pump with scientists at the Indian Institute of Agricultural Research in New Delhi. It was suggested that I

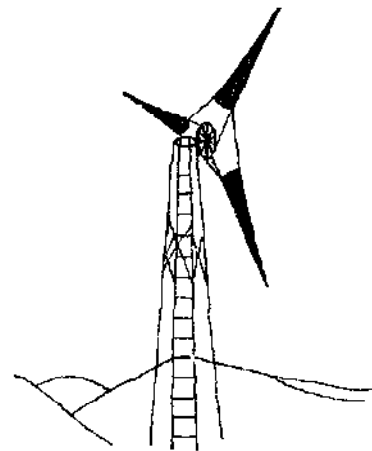

set up the windmill that I was planning for Tim's farm with a modified paternoster pump like those used to drain mines in England many years ago. I was given a working demonstration of some chain pumps at the I. A. R. I. and was told that a chain pump is easily and cheaply built and has the advantage of being more efficient than most other types of pump. Unlike some other pumps it operates well with a low speed variable power source like a windmill. Recently chain pumps have been replacing the traditional square pallet pump and the Noria water lifting wheel throughout China.

My friends in Delhi wished me good luck and I merrily proceeded on a delightful three day train ride by third class coach to the southern tip of the Indian subcontinent. I arrived at Tim's farm and we soon began construction of the windmill.

This sail wing windmill is made of a one-meter diameter bullock cart wheel to which three bamboo poles are lashed in a triangular pattern with overlapping ends. Each bamboo pole forms the leading edge of a wing, and a nylon cord stretched from the outer tip of the pole to the rim of the wheel forms the trailing edge. A stable and lightweight airfoil results from stretching a long narrow triangular cloth sail over that bamboo-nylon frame. This wing configuration, a hybrid of low-speed eight-bladed Cretan sail wings and high-speed two-bladed aerodynamic sail wings, produces high starting torque at low wind speeds. The bullock cart wheel is attached at the hub to the end of an automobile axle shaft which rotates in two sets of ball bearings. The shaft and bearing assembly is mounted horizontally on top of a turntable. The turntable consists of two circular steel plates separated with a raceway of ball bearings and held together with a ring of eight bolts which encircle the bottom plate. A one-foot diameter hole through the center

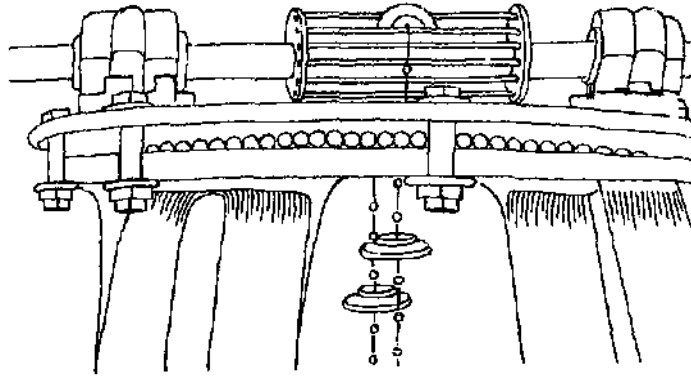

of the turntable will allow the chain and gaskets of the chain pump to go up and around the "squirrel cage" which is mounted at the center of the auto axle. If a reciprocating deep well piston pump were desired, the reciprocating rod, rather than a chain, would go through this hole and the crankshaft rather than an axle shaft would be mounted on top of the turntable. Since the blades have a slight built-in coning effect and the axle or crankshaft is mounted slightly off center from the center line of the turntable, the blades act as their own tail, trailing in the wind. Because the blades are downwind from the tower, there is no danger of the bamboo poles bending in a monsoon wind and hitting the tower. The tower is made of five 25-foot-long teak poles set in concrete at the base and bolted at the top to five angle irons welded at a slight flaring angle to the bottom of

the turntable. The tower tapers in towards the turntable at the top from a seven-foot diameter at the base. It has cross bracing and a ladder.

This eight-meter diameter windmill lifts three hundred pounds to a height of twenty feet in one minute in a ten mph wind. This is accomplished by a rope passing over a six-inch pulley on the main drive shaft. This lift is now being used to raise soil and rock from the 20-foot deep well which is being dug below the windmill. When the well is finished the pulley will be replaced by the "squirrel cage" of the chain pump.

I hope that other people will continue to refine and adapt this windmill to their own needs and materials. If you have any inquiries or suggestions for improvement, I will be pleased to reply.

— Marcus M. Sherman

New Alchemy Institute East
P.O. Box 432
Woods Hole, Mass 02543

MADURAI TYPE SAILWING WINDMILL: An eight meter diameter prototype sail wing windmill was erected Feb-March 1973 on a small farm owned by T.O. Heineman in a dry hill region of Madurai district, Tamilnadu. It lifted three hundred pounds to a height of twenty feet in one minute in a slight breeze. This was accomplished by a rubber rope passing over a six-inch pulley on the horizontal drive shaft.

This sail wing windmill is made of a one meter diameter bullock cart wheel to which three bamboo poles are lashed in a triangular pattern with overlapping ends. Each bamboo pole forms the leading edge of a wing, and a nylon cord stretched from the outer tip of the pole to the rim of the wheel forms the trailing edge. A stable and light weight airfoil results from stretching a long narrow triangular cloth sail "sock" over that bamboo-nylon frame. This wing configuration, a hybrid of low-speed eight bladed jib-sail wings and high speed two-bladed aerodynamic sail wings, produces high starting torque at low wind speeds. The bullock cart wheel is attached at the hub to the end of an automobile axle shaft which rotates in two sets of ball bearings. The shaft and bearing assembly is mounted horizontally on top of a ball bearing turntable.

The principal limiting factor is the availability of the steel turntable. This is the only component that cannot be assembled in an Indian village. A machine shop is required. The turntable consists of two circular steel plates separated with a raceway of ball bearings and held together with a ring of eight bolts which encircle the bottom plate. A dust cover or 2 large "O" rings should be incorporated to provide dust protection to the bearings. The services

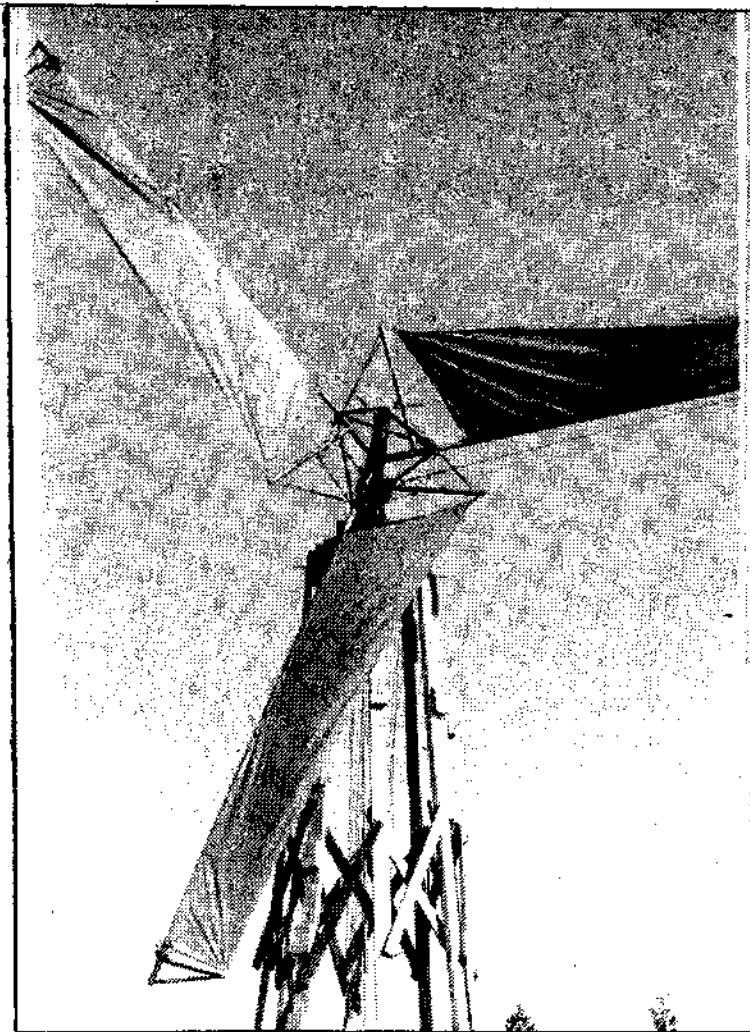

of a village wheel wright cum blacksmith are required for production of the oxcart wheel and mounting the wheel on the turntable shaft, the sails are manufactured on a standard sewing machine. The occasional presence of one person is required for operation. The Windmill is intended for the direct use and operation by its owner-builder.

Marcus Sherman
Madurai, India

Low Cost Sailwing Windmill, Madurai Prototype

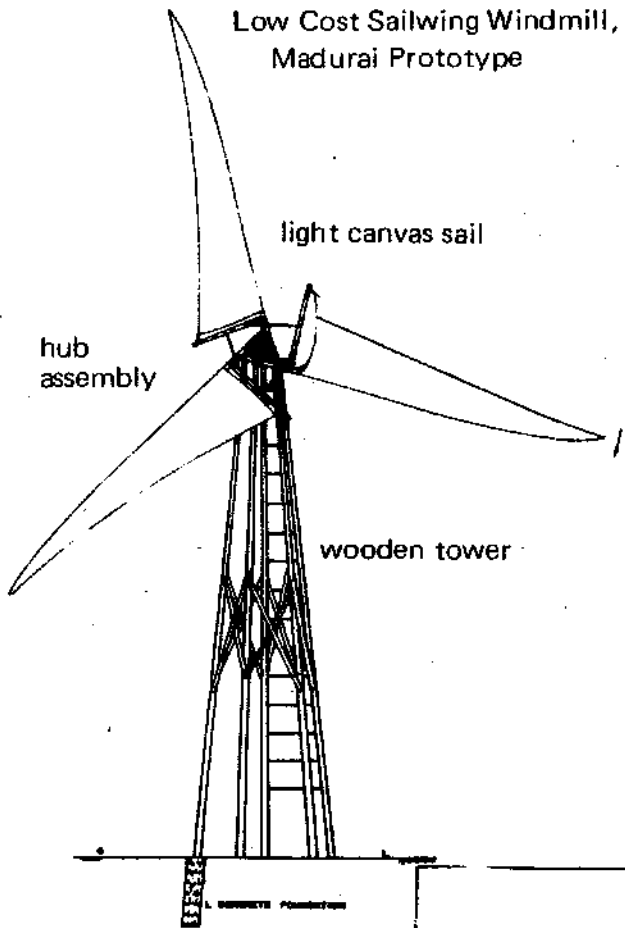

Windmill Turntable and Hub Assembly (side elevation)

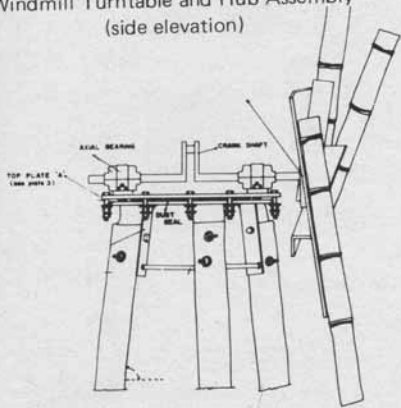

Hub Assembly and Sails
(Front View)

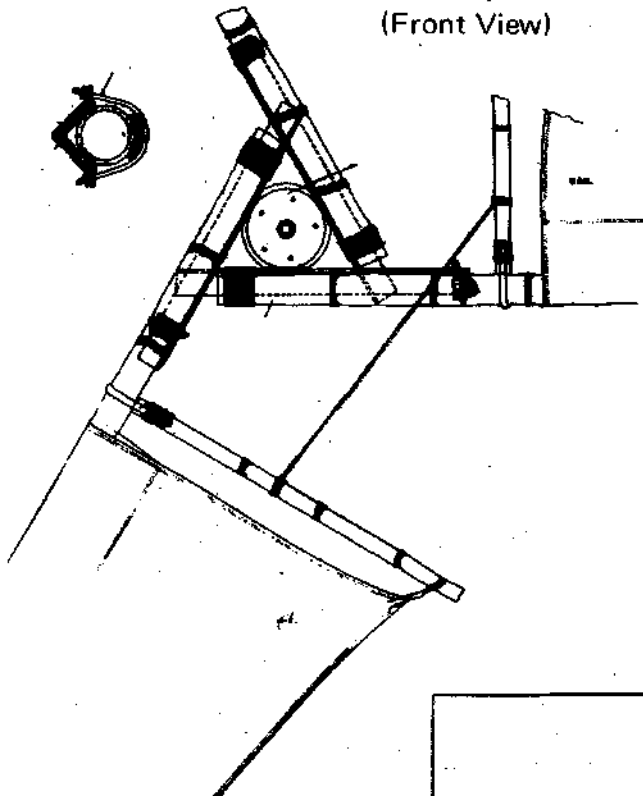

Hub Assembly (Rear View)

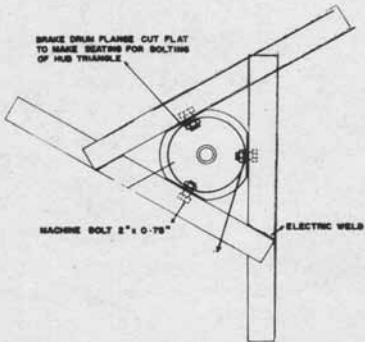

DETAIL

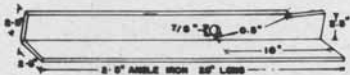

2.5" angle iron – 28" long

height = 2.5"

width = 2.5"

hole dia. = 7/8"

distance from edge to center of hole = 10"

measurement from hole to bottom top surface = 0.5"

cut-out drop measurement = 0.5"

measurement from hole to bottom top surface = 0.5"

cut-out drop measurement = 0.5"

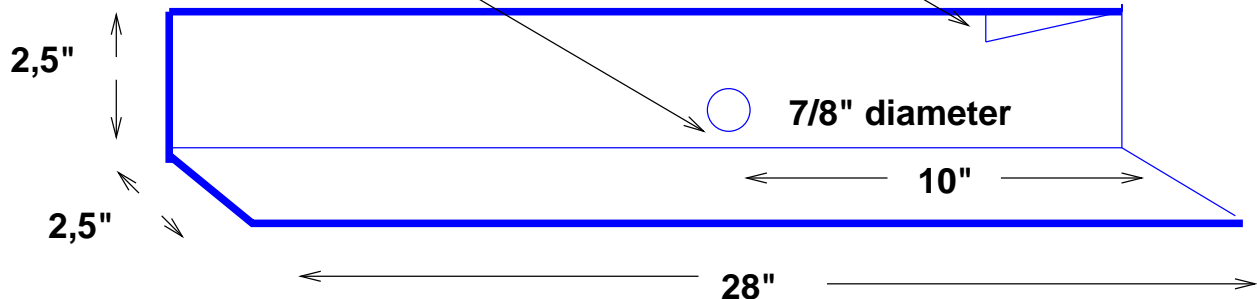

DETAILS OF THROAT (FROM FIG. 1)

FIG. 10

FIG. 11

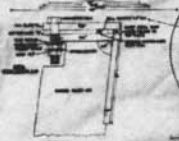
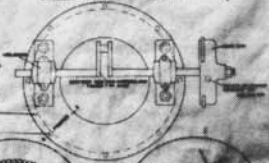
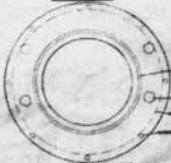

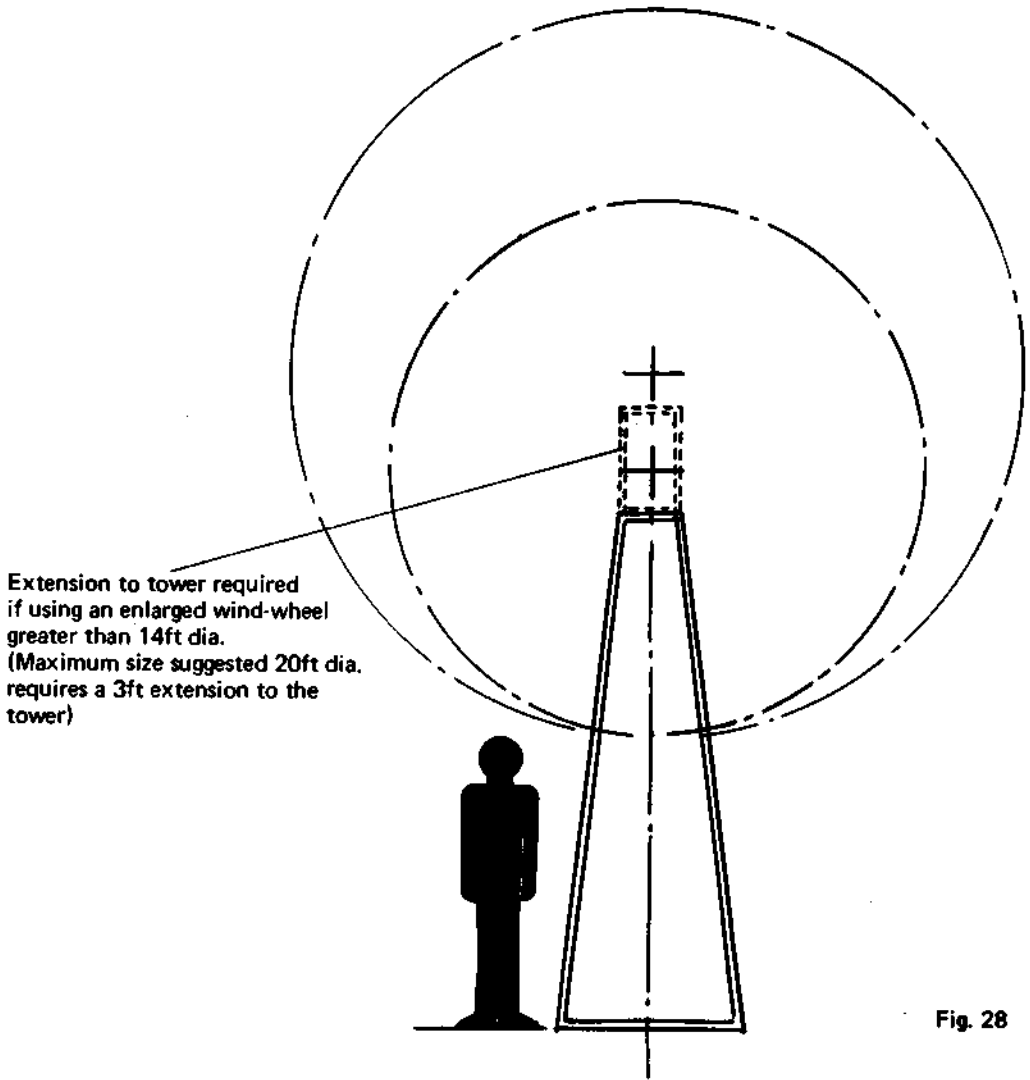

Fig. 28

Recommended six sail rotor with sails extended as close to the hub as possible. Existing sail as used on smaller wind-wheels is shown dotted.

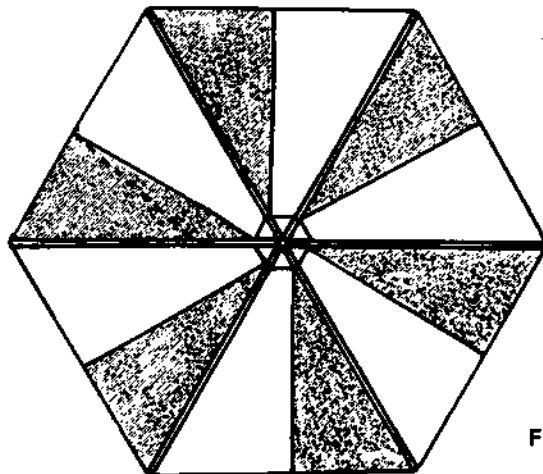
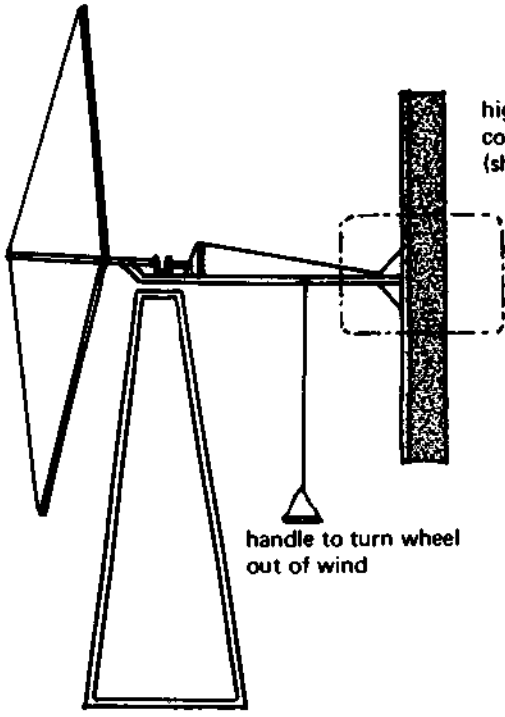

Fig. 29



high aspect ratio tail compared with standard tail (shown chain dotted)

handle to turn wheel out of wind

High aspect ratio tails
Fig. 30

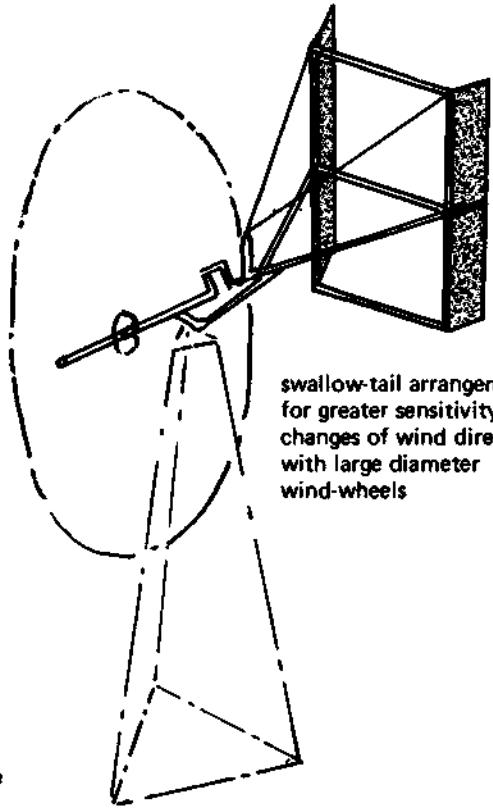

swallow-tail arrangement for greater sensitivity to changes of wind direction with large diameter wind-wheels

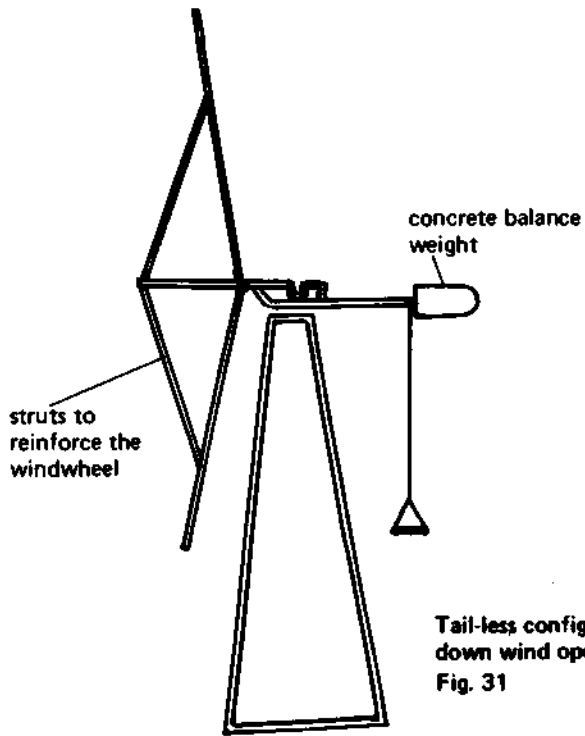

concrete balance weight

struts to reinforce the windwheel

Tail-less configuration for down wind operation
Fig. 31

Fig. 32
Double acting pump
conversion

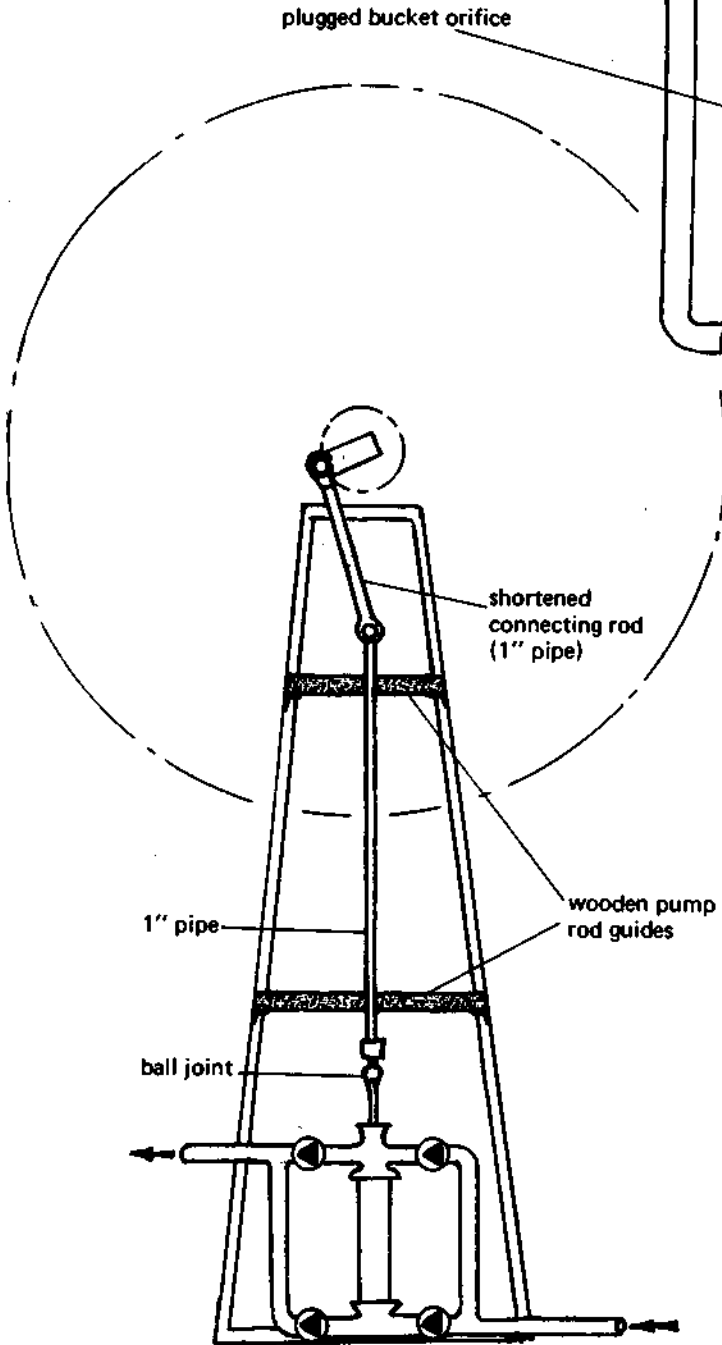
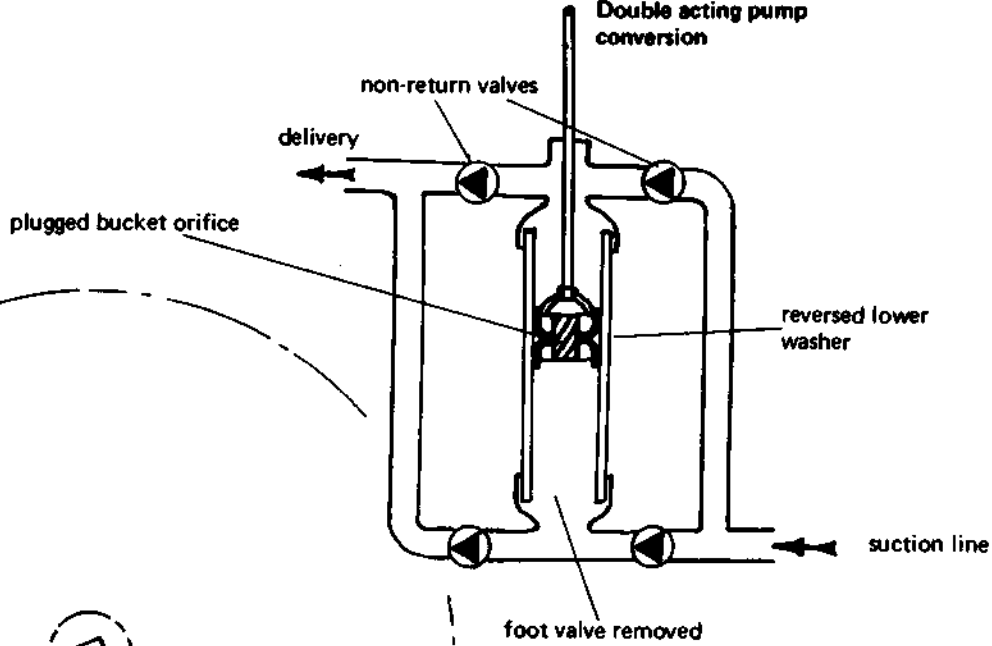

Fig. 33
Stiffened transmission for
double-acting pump

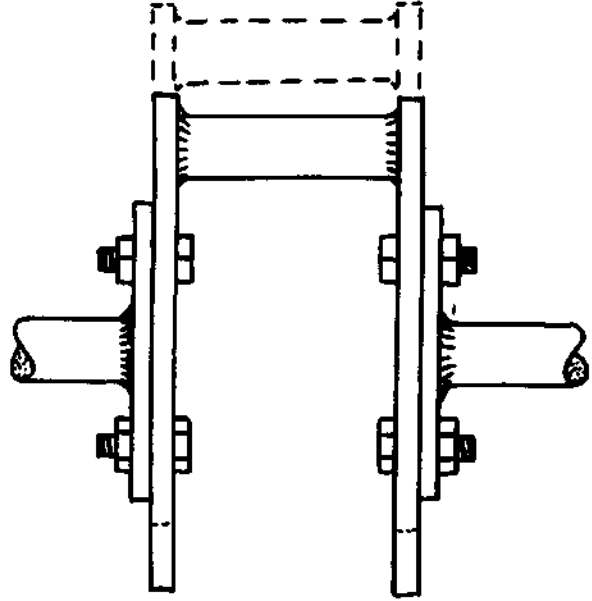

Fig. 34 Adjustable throw crank

Fig. 35 Method for fabricating crank to ensure correct shaft alignment after welding

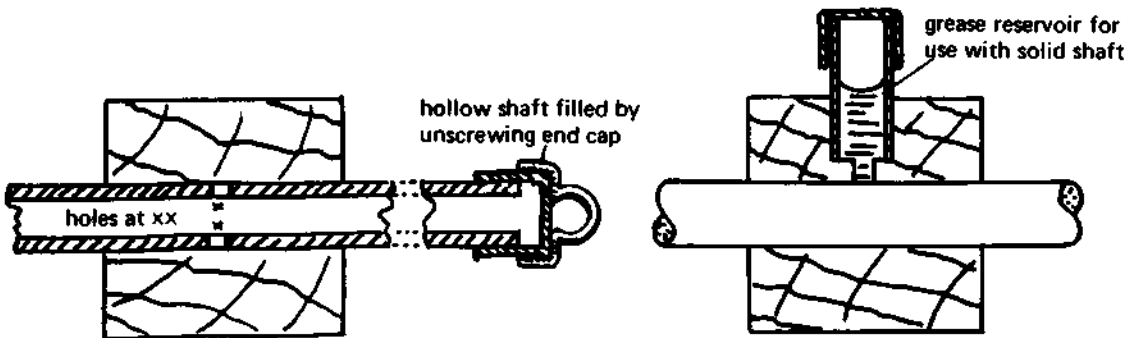
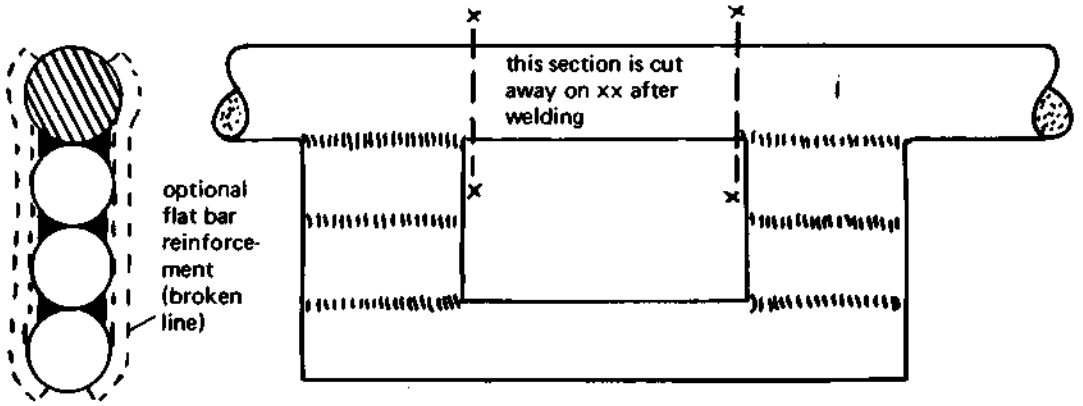

Fig. 36 Grease lubrication systems for wooden bearings

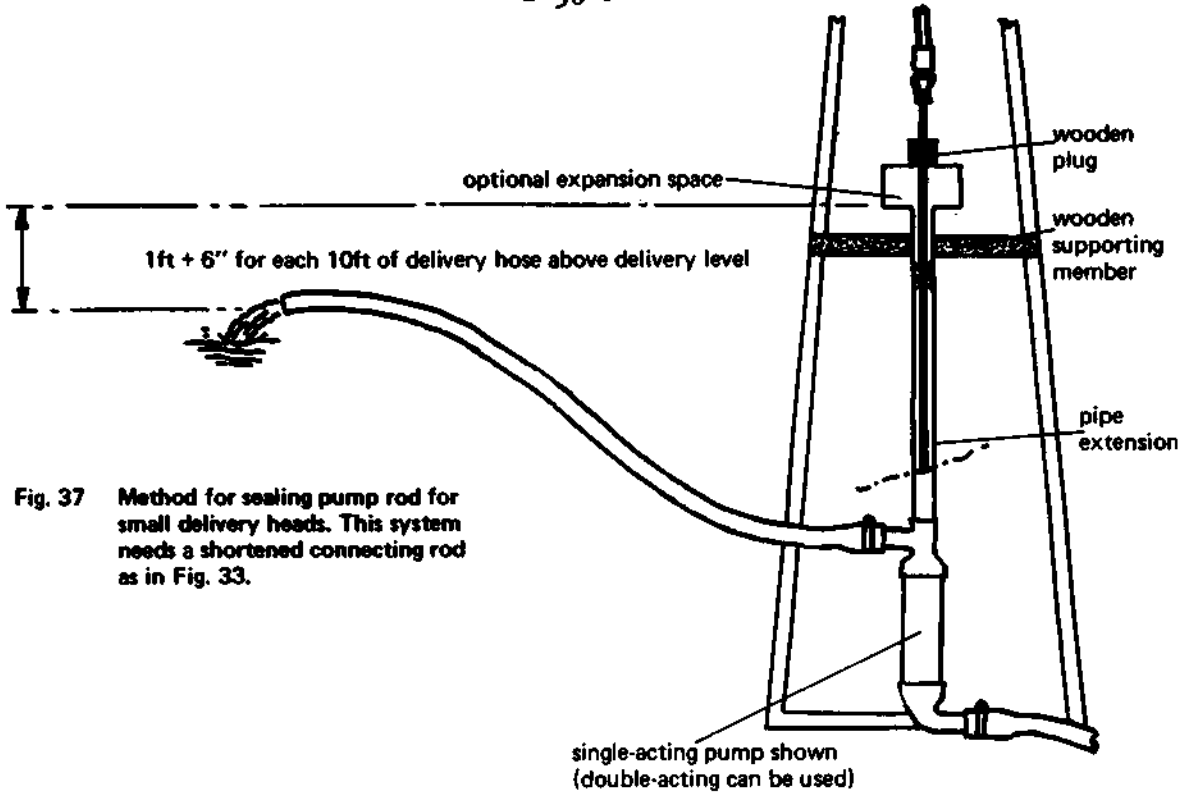
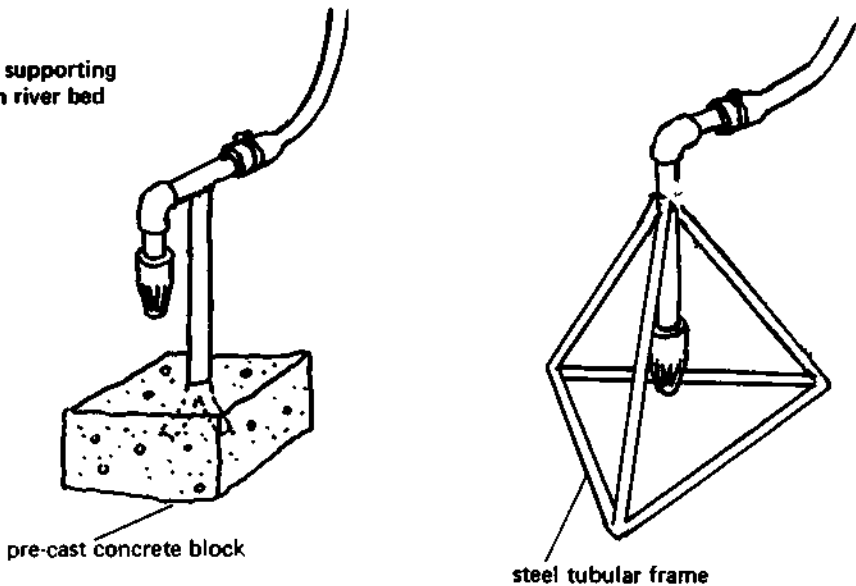

Fig. 37 Method for sealing pump rod for small delivery heads. This system needs a shortened connecting rod as in Fig. 33.

Fig. 38 Methods for supporting foot-valve on river bed



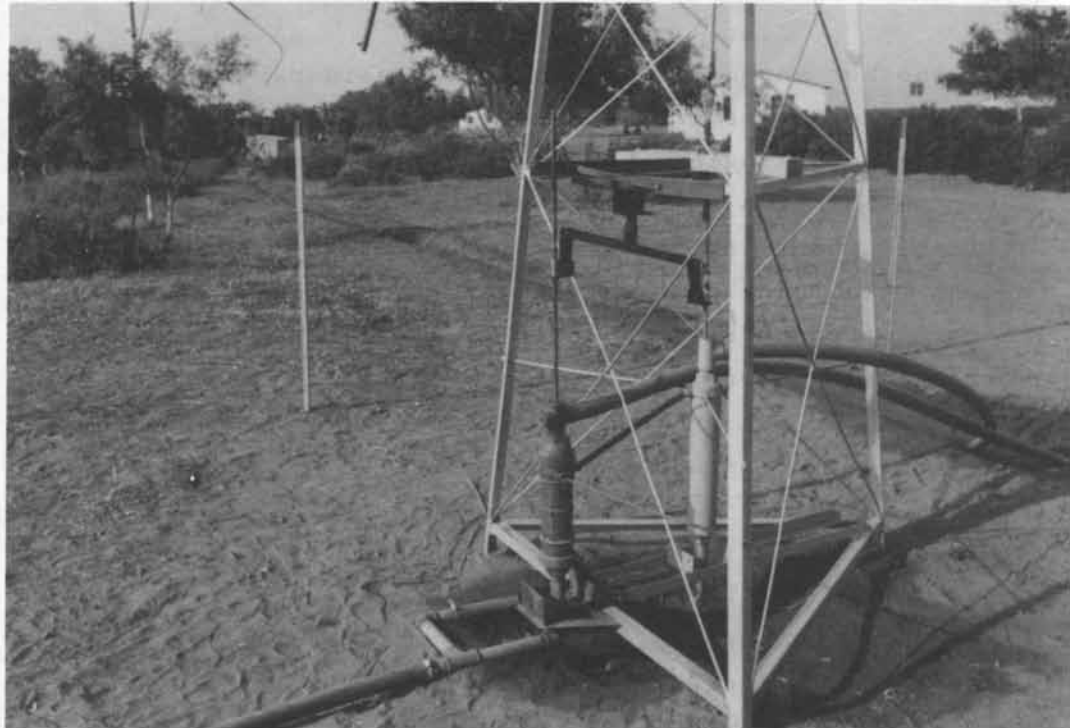

Fig 18. Double pump arrangement.

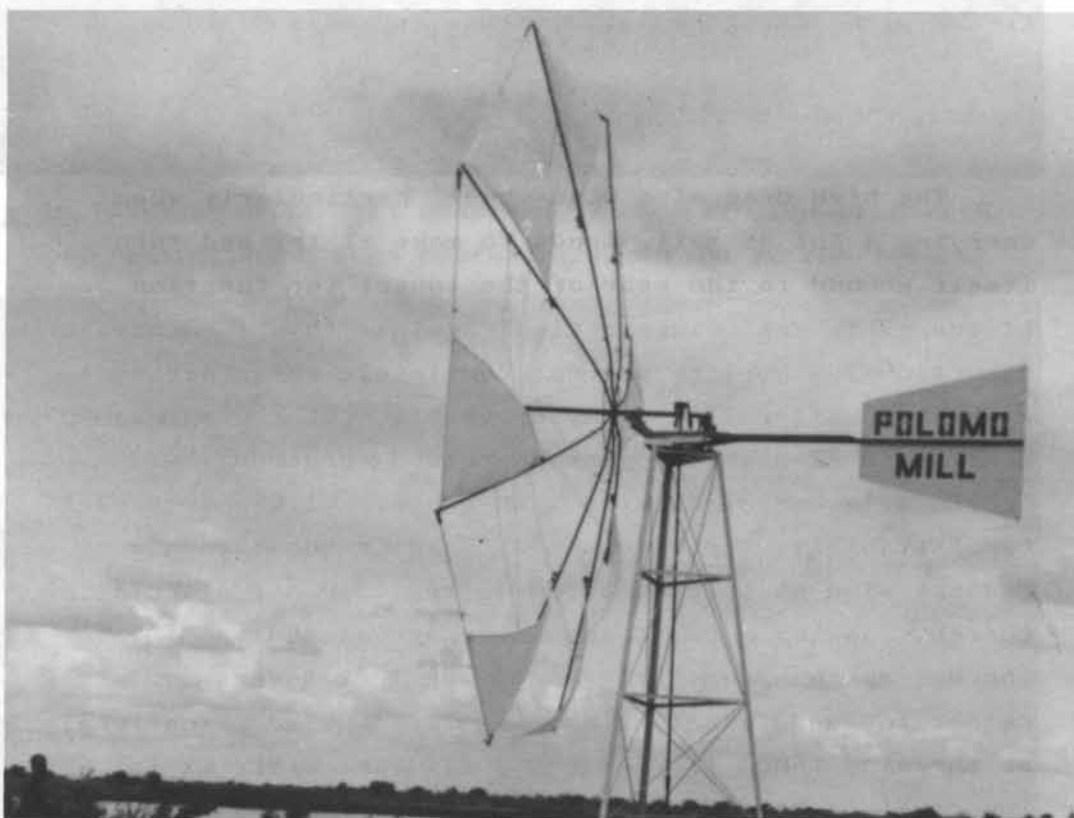

Fig 19. Interim extended tail.