

*Energy*



*If the section on energy for the fourth Journal was a bit thin, registering only our on-going and unalterable opposition to nuclear power and offering no word of our own work, it was because a report of our recent windmill work was, at that time, premature. Happily, that is not the case this year. Having found a reliable pump made from a trailer tire that is geared to the capacity of our water-pumping sailwing on Cape Cod, we feel that we have developed a water-pumping or irrigation system that is worthy of replication and adaptation. The New Alchemy Sailwing is the subject of the windmill article by Earle Barnhart and Gary Hirshberg and was first published in Wind Power Digest for the winter of 1977/78. It summarizes the evolution of the mill over the four years from its inception to its present form. One notable windmillish fact that Earle and Gary do not mention in their sketch of windmill history is that England's Domesday Book of 1086 documents five thousand mills, one for every fifty households. There is something rather nice about being part of the renewal of a technology that has served people well before, a sense of commonality with the past, perhaps.*

*The companion article to that by Earle and Gary is by Tyrone Cashman and describes the mill that he built for the Zen community at Green Gulch in California, using the New Alchemy sailwing as a prototype. In addition to the background and the actual construction of the Green Gulch sailwing, he discusses the modifications he made to adapt to conditions very different to those on the Cape. This is interesting for us as New Alchemists because, like Meredith Olsen's in the Aquaculture Section, it is the first documented feedback we have had on a second generation of the application of our ideas and, as such, it opens wider channels for comparison and critique.*

*The final article in this year's Energy trilogy is by Joe Seale who has spent the last year working with the HYDROWIND, the electricity-generating, hydraulically-operated mill that New Alchemy has developed on Prince Edward Island in Canada. Joe, who has since joined us on Cape Cod, explains the pros and cons of HYDROWIND I after a year's study and testing. He discusses the machine in some detail and evaluates not only this particular mill but various theoretical approaches to aspects of windmill design. He sees a need to make available in writing a body of knowledge that has been until now largely oral and, as such, scattered and lacking in organization.*

— NJT

Photo by Hilde Manglov

# The New Alchemy Sailwing

— Earle Barubart and  
Gary Hirschberg

Over the past several years we have been investigating the applications of wind-powered water-pumping systems. We have been particularly interested in sailing windmills which generally can be constructed of indigenous materials with limited equipment by people who are not trained specialists. In contrast to more sophisticated designs, sailwings can be adapted to places poor in resources such as rural areas or third world countries. Windmills have been used for irrigation for more than twelve centuries in areas where cultivation would be otherwise unfeasible.

At New Alchemy on Cape Cod we needed a water-pumping system for aquaculture projects and to irrigate the gardens. We wanted to design a windmill that could be constructed by a do-it-yourselfer using local and/or available materials. It was important that our water-pumping system be simple and inexpensive, require very little maintenance and be storm-resistant. The windmill had to be adjustable for varying wind speeds and wind directions. It was essential that it be operative in areas of low wind speeds for it to be broadly practicable.

Four years of experimentation and research, beginning with Marcus Sherman's bamboo/cotton sailing windmill in Southern India, have culminated in the design and construction of the New Alchemy Sailwing which meets these objectives. Familiarly known as "Big Red" (Figure 1), it was named for its first set of bright red sails. It pumps in winds as low as 6 miles per hour and in gales of up to approximately 40 mph. Although our water-pumping needs do not extend into the winter, the Sailwing is operable throughout the year. People with year-round demands need only take normal cold weather precautions against pump or water-pipe freezing damage.

## *Sailwing Description*

On top of the 26-foot wooden lattice tower, a horizontal axle leads to the junction of three steel masts (Figure 2). The multi-colored Dacron<sup>(R)</sup> sails are attached to the masts by grommets and pegs, like the rigging of a sailboat. Elastic shock cords connected to the adjacent mast pull the sail root out to form a smooth surface for catching the wind. The shock cords allow for self-feathering and easy furling in storm conditions. The sail tips are attached to fixed triangular pieces at the ends of each mast.

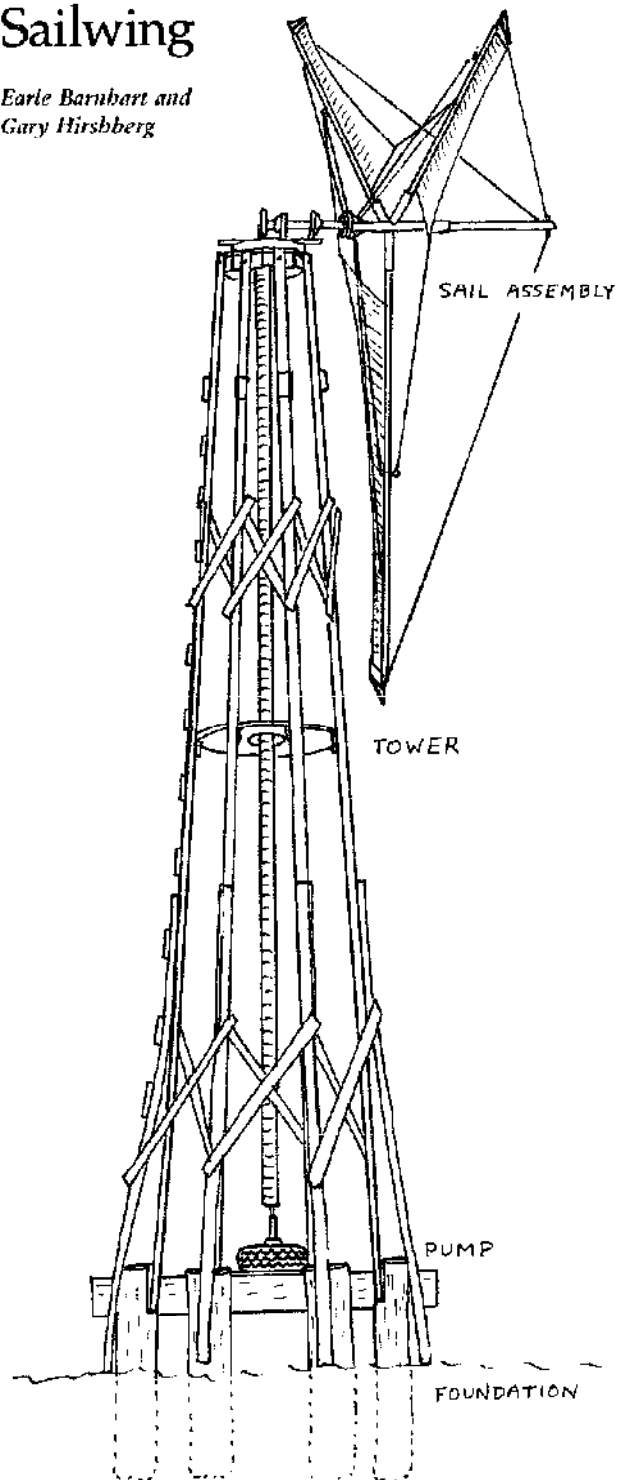

Fig. 1

All drawings by Earle Barubart

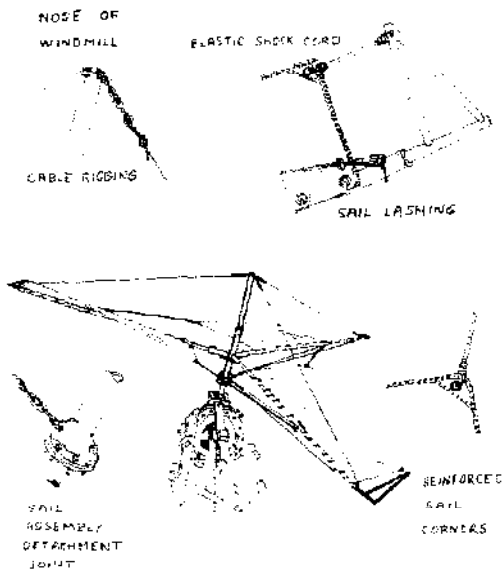

Fig. 2

The axle and sails are oriented downwind from the tower, eliminating the need for a tail. Wind power is transferred along the rotating axle through a pair of sealed commercial bearings (Figure 3). A steel disc crankshaft mounted at the base of the axle transfers the axle rotation to the vertical motion of the pump shaft. Five distinct stroke settings are provided by holes drilled at different radii from the disc center. The assembly is centered on a steel plate turntable above the tower. The adjustable stroke disc is centered directly above a hole in the turntable through

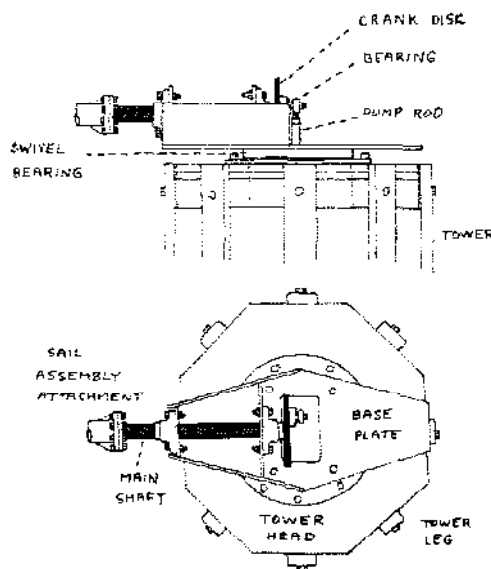

Fig. 3

which passes the pump shaft. From the disc, power is carried down the tower along a three-inch diameter shaft to a diaphragm tire pump at ground level (Figures 4 and 5).

The windmill tower is made of eight 2 x 4 legs bolted to buried sections of telephone pole. Curved wooden buttresses add support at the base and two sets of latticework give additional stability above. A secondary platform rests approximately halfway up the tower.

#### Origins of the Sailwing Windmill.

A brief look at windmill history indicates that the New Alchemy Sailwing is a scion of considerable heritage. The origins of windmills are somewhat obscure, but primitive horizontal mills are thought to have been employed in seventh century Persia. Legends recount that prisoners of the Genghis Khan carried the idea of wind-powered grinding and water-pumping mills to coastal China. There, horizontal mills with matted sails came into use. These primitive mills became obsolete by the end of the twelfth century as the application of Chinese sail-making increased the sophistication of windmill construction. The sailwing had an unparalleled maintenance-free life-span due to its durability and simple, lightweight design. It gained widespread application throughout coastal China. The same criteria explain the ubiquitous employment of sailwings in China and Southern Asia today.

The European windmill developed independently of its Asian counterpart. The first documented mill was used for grinding grains in England during the latter part of the twelfth century. By the seventeenth century, due largely to the extensive exploitation of wind both on land and sea, the Netherlands had become one of the wealthiest nations in the world. Cloth was the commonly-used material for windmill sails during this period, reflecting its application on sailing ships. Among the advantages of cloth were light weight, ease in handling, low cost and availability. Most importantly, when supported at three or more points, cloth forms a strong uniform surface for catching the wind.

These advantages hold true today, as is evidenced by the widespread use of cloth for windmill sails. Currently, handcrafted sailwings are employed in Crete, India, Ethiopia, China and Thailand, among others. Researchers at Princeton recently have developed a two-bladed high-speed aerodynamic Dacron<sup>(R)</sup> sailwing for use in the United States.

#### 1973:

Marcus Sherman and Earle Barnhart first experimented with sailwings at New Alchemy in the summer of 1973. They devised a three-bladed wood/canvas sail propeller which was used for driving pumps and power tools. Although this model was destroyed by a January

ice storm, Marcus was encouraged by the simplicity and efficiency of the sailing concept.

**1973-1974:**

In Southern India that winter, Marcus built his first water-pumping sailing windmill. There local farmers were experiencing hardship induced by the vagaries of monsoon-related droughts and flooding. Inadequate and costly power sources made reliable irrigation difficult. There was, however, a large untapped supply of groundwater. This prompted Marcus to consider harnessing the wind for irrigation on the farm of a friend. To complete the irrigation system, scientists at the Indian Institute of Agricultural Research in New Delhi recommended a modified paternoster pump, like that used to drain the mines in Britain in the late sixteenth century, because of its simplicity and low-cost construction. Chain pumps such as this work well with the relatively slow and variable power that is characteristic of windmills.

Marcus developed a mill that was a hybrid of the low-speed, eight-bladed Cretan sailing and the high-speed aerodynamically-efficient Princeton model — "A Windmill in India", the second *Journal*. Using a bullock cartwheel roughly one meter in diameter as the hub, he attached to it triangular sailing frames made of bamboo and nylon. A cloth sail was stretched over the frame to produce a stable, lightweight airfoil. The rotor assembly was attached to a used automobile axle. Marcus made a turntable from ball bearings sandwiched between two doughnut-shaped discs. The axle was mounted horizontally on top of the turntable. A rudimentary "squirrel cage" assembly for housing the drive chain and gasket pump was centered on the axle directly above the one-foot-diameter hole in the turntable.

The sailing was headed downwind to prevent the bamboo poles from bending and striking the teak pole tower in monsoon winds. In this way the blades served as their own tail, trailing in the wind. In the process of the subsequent well digging, the mill was used with a pulley assembly to raise soil and rock from the 20-foot-deep well. Because of its high starting torque at low wind speeds, the mill proved well suited for year-round irrigation in Southern India.

**1974:**

Back at New Alchemy the following summer, Marcus, with Earle, gave the sailing concept another try. With lumber and hardware, they built a durable prototype well able to withstand the often blustery Cape Cod climate. For a total material cost of \$300, they developed an 18-foot-diameter, cloth sailing capable of pumping 250 gallons per hour in 6 mph winds. Three tapered cloth sails, supported by tubular steel masts, extended from a triangular plywood hub. A moveable boom was secured at the

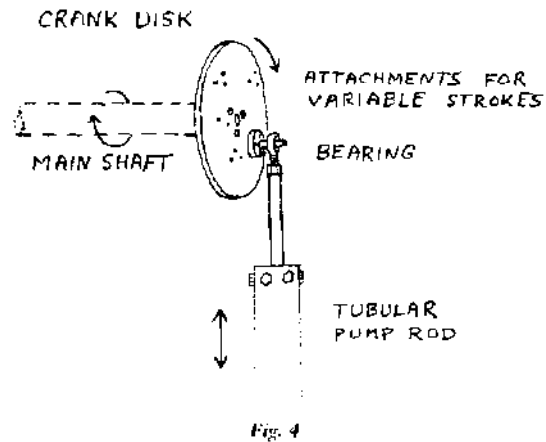

root of each sail by a leather strap to further self-feathering. Long metal doorsprings connected each of the three sail booms. In early tests, the feathering mechanism withstood a force-nine gale.

A used automobile crankshaft formed the hub and crank. The assembly turned on a ball-bearing turntable which allowed the windmill to seek a downwind operating position. A recycled piston rod on the crankshaft transferred power to a reciprocating vertical steel pipe pump shaft. The shaft operated a high capacity piston-type pump below. The entire struc-

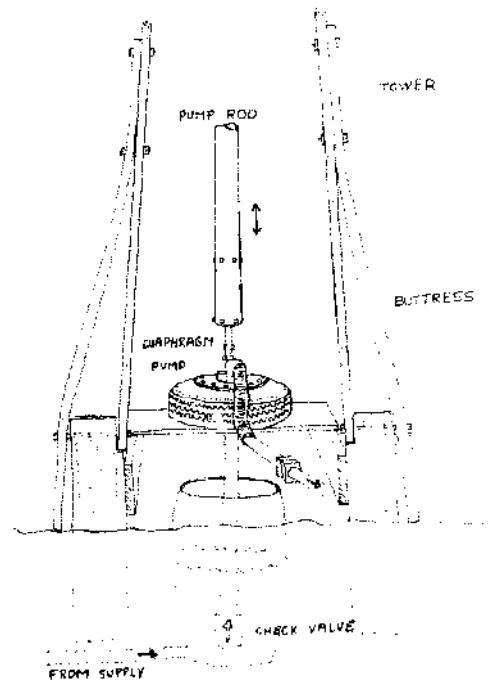

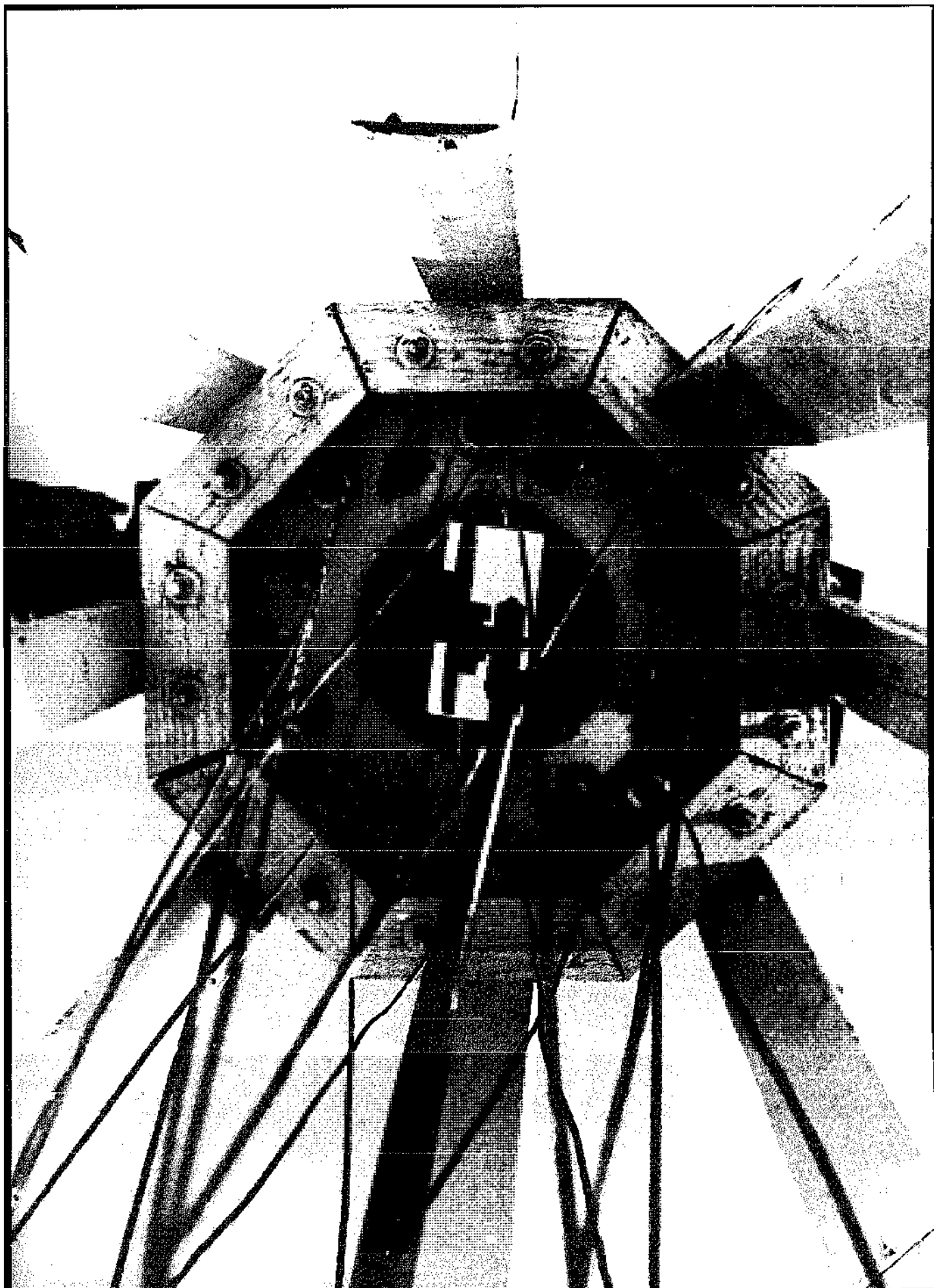

ture was mounted on a firmly-braced eight-legged wooden tower.

The windmill supplied water to a series of twenty small ponds used in our ridge experiments. It was operational in high winds, although the cloth sails were removed in severe storm conditions. The cotton sails were later replaced by Dacron<sup>(R)</sup>, which is longer-lived, holds its shape better, does not absorb water during rains and is stronger and lighter than cotton. On preliminary testing, Marcus found the performance of the mill to be significantly lower than its calculated pumping capacity. A double pump was used. This and subsequent models employed downwind sailing blades which minimize the chances of the sails tangling in the tower while feathering and eliminate the costs of a large tail.

#### 1975-1976.

The current model was built in 1975 and incorporates many of the features of its prototypes. Several new ideas were tried. An extension shaft was added to position the hubs and blades further from the tower. We had noticed that the slip-on sock-like sails frayed where they were wrapped around the blade shaft. Traditional sail makers advised us to attach the sails with grommets and pegs and to position a stabilizing cable from wing tip to hub to prevent flexing of the blades. In addition, we added a simple spring-feathering device to each of the sailing tips.

The double pumps used previously with the prototype proved undersized for the strength of the new model, so a higher capacity and more compact diaphragm pump was tried. Tests were also carried out with a deep wooden piston pump like a marine bilge pump, but the diaphragm was more reliable.

The auto crankshaft that made up the hub and crank on the prototype was found to yield too small a stroke for the mill, so Mac Sloan, an engineer who advises us on windmill problems, devised an ingenious disc-bearing assembly to drive the pump (Figure 3). The disc/bearing assembly functions as a crank with a variable pumping stroke. Sealed commercial bearings were added to the windmill shaft at this time, as the original homemade bearings wore too quickly and demanded frequent lubrication. Curved buttresses were attached to the tower legs to support the additional weight of the crankshaft, extension and other hardware which had been added subsequent to the original design.

#### 1976-1977:

Several other features have been improved since the spring of 1976. Strong elastic shock cords have replaced the door springs used for self-feathering, resulting in increased flexibility and smoother sail motion. The shock cords are easier to maintain and preclude the need for a boom.

Mac Sloan helped with another part of the present sailing system. He designed a smaller diaphragm pump, adjusted to the mill's one-gallon-per-stroke capacity. Once the pump was able to handle the mill's power, the pump shaft became the weak link. Excessive flexing in the half-inch pipe shaft led us to replace it with a rigid three-inch EMT shaft.

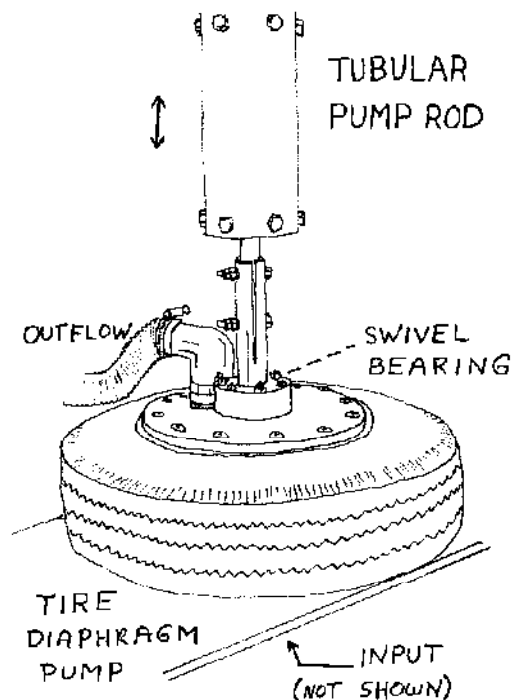

Fig. 6

#### Operation and Maintenance.

**Self-feathering:** In normal winds (0-15 mph) the taut sails catch the wind and drive the pump. In higher winds (15-30 mph), increased forces on the sail press downwind, stretching the elastic shock cord and allowing some of the wind to spill past the sail. This automatic feathering results in continuous pumping in higher winds without destruction of the blades.

**Reefing:** During very high winds and gales (> 30 mph) we protect the windmill by reefing the sails. The blades are stopped by hand from the mid-tower platform and each elastic cord is unhooked from its metal mast attachment. Each sail is wrapped around its own mast pole several times and then bound by winding the cord around the sail and hooking it. This arrangement leaves only a small triangle of sail exposed at the outer end of each mast, which in high winds is often enough to continue pumping.

**Adjustments:** Several adjustments can be made to adapt the windmill to different average winds or pumping requirements:



Photo by Heidi Mangav

**The Pump Stroke** - The pump stroke of the windmill has five settings depending on the attachment point of the pump rod to the crank disc. In a given wind, the windmill can perform a fixed amount of pumping work which can take the form of a low lift of high volume or a high lift of low volume. Our winds average 8-9 mph in summer and our need is to pump the largest volume possible to a height of four feet. Our custom-made diaphragm pump lifts .875 gallons per two-inch stroke in average winds. In high winds we have measured 700-800 gallons per hour.

Combinations of stroke-length, pump volume and height of lift must be developed for each application and site. Sailwing windmills such as this one have been used with piston pumps for 20-foot lifts/10-foot heads and with chain and trough pumps in Southeast Asia for low-lift irrigation.

**Shock Cord Tension** - The response of the windmill to varying winds depends on the tension of the elastic shock cord holding the sail taut. A mild tension aids operation in low winds by creating a steeper angle of attack as the sail partially feathers, but spills most of the higher winds. A strong tension reduces starting ability in low winds by creating a flat attack angle, but spills less energy in high winds.

**Blade Tip Angles** - The angle of the sail to the wind at the tip of each blade also affects the windmill in varying winds. A steep angle creates high starting torque but limits rpm once the windmill is turning rapidly. A flat angle give less starting torque, but once started causes a greater rpm in higher winds.

In our aquaculture circulation application, where continuous pumping is ideal, a mild shock cord tension and a steep tip angle of 40° results in low-wind starting and pumping as often as possible.

We offer these simple cautions in working with the mill:

- Stop the windmill and wear a safety harness while on the tower.
- Avoid allowing the windmill to free-wheel without a pumping load.
- Protect water lines from freezing for winter pumping.

We are, overall, well pleased with the New Alchemy Sailwing. It is beautiful, functional and durable. It performs well the task we ask of it. After four years, it meets the objectives we originally postulated and, in terms of cost, labor, efficiency and usefulness, when contrasted with more standard research and development models, it seems genuinely to qualify as appropriate technology.



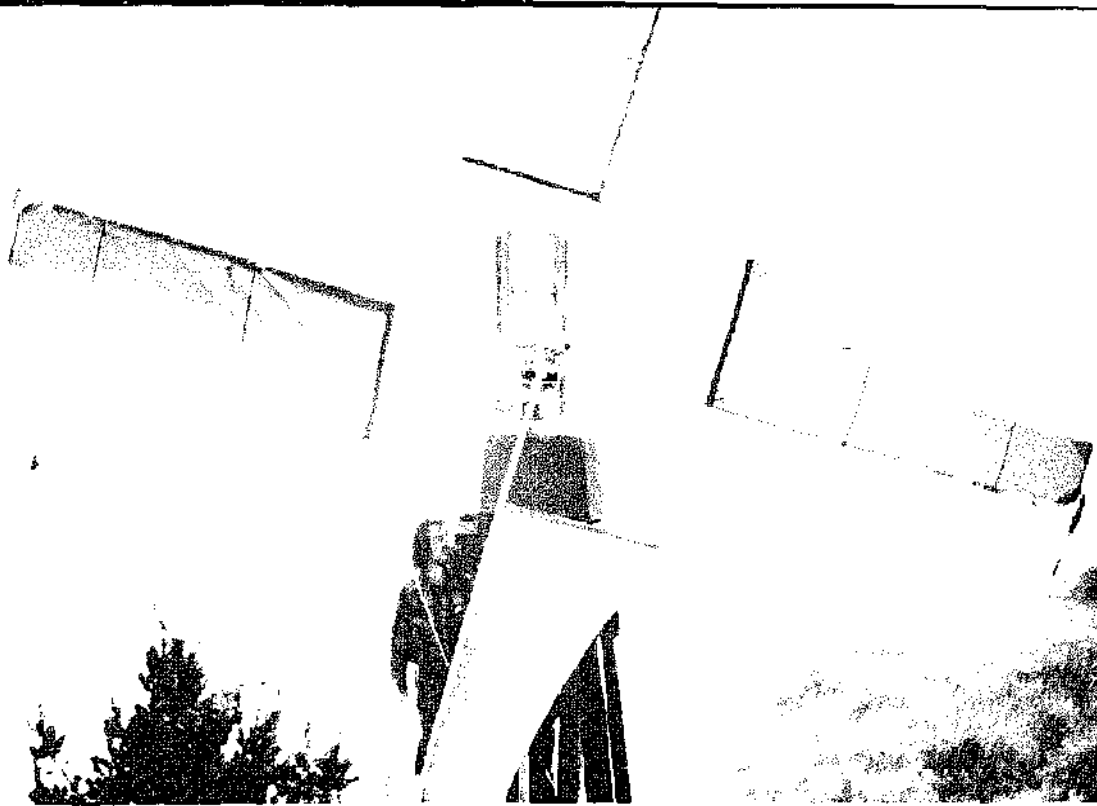

## The Green Gulch Sailwing

— Tyrone Cashman

The Green Gulch sailwing windpowered irrigation pump was conceived of and implemented jointly by the Arca Foundation, the Zen Center and the New Alchemy Institute. For the Zen Center it represents the first step in the integration of wind energy into their stewardship of their valley.

In the long range, Green Gulch Farm, as a permanent agricultural/natural cycle based community, will reap increasing advantage in food and energy from the recycling of water, of human, plant and animal waste material, and a pragmatic and benign use of wind, sun and gravity-powered water flow.

The community is destined to become a model of gentle stewardship of land — receiving from it a true abundance, while under its guiding hands the soil, ponds, gardens, hillsides and total landscape become richer, more biologically diverse and more beautiful year by year.

The Green Gulch Sailwing provides irrigating water, a constant reminder of natural forces, and basic experience in wind technology for those who helped design and build it and for those who will operate and maintain it. Further wind projects for grey-water aeration, milling, winnowing, water pumping and

electrical generation will easily be incorporated by the community through the practical experience and understanding this windmill is providing.

Besides the practical and economic value of this mill, there is an aspect of equal importance and equally appreciated by the community: the mill is beautiful as it turns. The evening sun glows through its sails. It graces the valley as it responds to gentle movements of air. And it is quiet — as it must be (and few windmills are) for its location within yards of the meditation hall in a meditative community.

As a research entity in gentle technologies, New Alchemy sought two goals with this sailwing: (a) to create a wind-powered irrigation system carefully tuned to the bio-region and even to the microclimate of Green Gulch Farm and (b) to advance its research on the problems of inexpensive, durable, simple, high volume/low wind windmills — mills that can also withstand relatively high winds without human intervention.

One of the key problems in inexpensive windmill design is to design for both high and low winds. Since the energy in winds increases *by the cube* of the wind-speed, windmills that are light and large enough to

produce work in winds under 10 mph are extremely vulnerable to the exponential increases of energy in higher winds.

In designing for the Green Gulch valley, there is the advantage that, for three seasons of the year — spring, summer and fall — when most of the irrigating must be done, the winds are quite tame. Rarely will a wind come up that is over 20 mph. In winter, storms can be expected with winds to gale force and beyond.

The average recorded wind in the lowest wind season — April/May — at the windmill site was 4.44 mph in 1977. The design of a mill which will do regular and significant work in a 4 mph wind regime and still weather winds of 30 to 35 mph without human attention was our goal.

A windmill that is available commercially, such as the American multi-blade sold by Aermotor, Dempster, is the end product of a design that ceased evolving significantly in the 1930's. It begins pumping in light winds due to a 3-to-1 down-stepping gear ratio, giving it added torque to overcome start-up inertia, static head and friction in light winds; but it pays for that torque with a loss of 2/3 potential volume of flow, extra friction in the gear mechanism and considerable expense intrinsic to the production of strong, slow-speed gear wheels.

The rotor, which is made of rigid metal blades, must be turned out of the wind when winds are too high — and extra mechanisms are provided to perform this function either automatically or manually. The construction is of metal.

The advantage of the American multi-blade design is that it is proven to be safe and reliable, requiring little operator attention. These mills are especially well-designed for remote stock-watering operations.

We priced the largest Dempster, which has a rotor diameter of 14 feet and an appropriate tower for our site, and found that the combination turned out to be over \$4,000, not including the pump.

The windmills found on the shores of the Mediterranean are designed for the constant, relatively light winds of their region. Cloth is used for sails and wooden spars, windshafts and even wooden bearings are traditional. These mills are inexpensive and responsive to light winds, but their sails must be furled or removed before a storm or if the mill is to be left unattended for a long period of time. Such constant watching and attention are not to be expected of the American farmer or horticulturist.

For several years, New Alchemy has been engaged in the development of simple, low-cost sailing water-pumping windmills which would be adaptable to diverse wind regimes and which would combine the best qualities of the American multi-blade and Mediterranean mills. The Green Gulch Sailing may not be that model yet, but it is, on several fronts, a large step

forward in the improvement and refinement of the basic design.

Parallel to the development of New Alchemy Sailing, a small group of missionaries in Omo, Ethiopia, have been developing and testing a variety of sailing mills for low-level irrigation pumping. The results of their experiments are recorded in a book by Peter Fraenkel of the Intermediate Technology Development Group in London: *Food from Windmills* (London: ITDC, Parnell House, 25 Wilton Rd., SW1V 1JS, 1975). These practical experimenters found some of the New Alchemy ideas and data useful in their work and, in turn, some of their results have been helpful in the design of the Green Gulch Sailing.

## DESIGN AND CONSTRUCTION

### A. The Site

The mill site was chosen by several criteria:

1. Close enough to the water source that the pump at the base of the mill could be no more than approximately 10 feet above the water surface in all seasons. At this distance a pump which operates frequently enough to keep its leather piston rings moist will not need to be primed. This is essential for a windmill pump which of necessity stops operating for periods of time when the wind dies entirely.
2. Good access to the wind. The site is one hundred yards from the nearest obstruction of its own height, a row of windbreak trees, and is directly behind a gap in the trees in the direction of the prevailing winds.
3. Enough space around the tower base to allow additional devices (air-compressor, winnower, thresher, grinder, etc.) to be connected to the present pump shaft should need dictate and appropriate devices be found or built.
4. The mill is located within sight of the office, the dwelling area and the fields. It is not wise to locate a newly designed windmill out of sight. Young people are tempted to climb it while it is working, if no one is looking. Also, if any aspect of the mill needs attention, it can receive it before the mill damages itself.
5. The site is out of the way of walking and gardening traffic.

### B. Tower

The tower is designed to use low cost, light weight materials, pine 2 x 4's. Tower strength is achieved by spreading weight and windpressure over eight legs. The tower foundation is eight recycled redwood railroad ties, painted with creosote and buried three to four feet in the clay soil. Strength and convenience in mill maintenance is provided by two circular platforms dividing the tower in thirds. Rigidity is ob-

tained by cross-bracing with 1 x 3's on the lower bays and by simply doubling the 2 x 4 legs in the upper bay, which allows maximum wind passage through the tower at sail level.

The advantages of wood over metal towers are: cost, local accessibility and long-life as, with constant slight bending and vibration, wood will not fatigue, whereas metal can.

### C. Turntable

#### DESIGN

Purpose:

1. To allow rotor, transmission and pump shaft to rotate 360° freely in the horizontal plane, in response to changes in wind direction.
2. To bear one ton of off-center load without wear or settling on the side opposite the prevailing winds.
3. To allow a minimum orifice of 2 square inches at the precise center of rotation for pump shaft to pass through.
4. To provide the chassis for all tower-top mechanisms.

#### CONSTRUCTION

We calculated that a free-floating rear axle from a 3/4 ton truck, when set on end, was capable of meeting all these specifications with a large margin. Such axles are available in scrap metal yards throughout this country and in many others around the world. The cheapest and probably highest quality turntable we could have used was this recycled truck axle. At the low revolutions per day of this application, there should be many years of life left in it.

Before the axle can be used for a turntable, the power shaft is removed from the axle, leaving a 3-square-inch passageway in the center for the pump shaft. The brake parts are removed and a 20-inch diameter disc of steel, 3/4 inch thick, is welded as a base for the axle to sit on. Braces underneath the wooden tower platform give added strength against lateral pressure from the wind.

Care must be taken to protect the bearings from rust through exposure to the elements. We protected the bearings with an aluminum cowling which covers the entire transmission. Another protective measure used by the Farallones Institute is to grease the bearings well with boat trailer axle grease (designed to be immersed in water) and cover the opening with the appropriate size jar lid, punctured so that the cut edges lead rain water down the pump shaft and away from the bearings.

### D. Transmission

Purpose: to transfer power from rotary (wind shaft) to reciprocal (pumpshaft) motion with maximum efficiency and durability and minimum expense and complexity.

This is accomplished with a 14-inch diameter steel disc, 1/2 inch in thickness, welded to a 2-inch sleeve, machined with a keyway and drilled for a hardened bolt. This disc and sleeve fit over the end of a 2-inch cold-rolled steel bar, 32 inches long, which functions as the wind shaft, bearing all the weight of the rotor and transferring the motion of the rotor to the disc.

The disc is drilled with three 1-inch holes, to any of which a 14-inch long, 3/4 inch diameter cold-rolled steel bar, fitted with rod end bearings on either end, can be attached. This connecting rod is further encased in a section of galvanized steel pipe for greater strength.

The connecting rod attaches to the vertical pump shaft at a junction point comprised of a steel box welded of 3/4-inch plate with two industrial castors welded to each side. These provide a rolling lateral bracing which forces the side-to-side motion of the disc and connecting rod to be translated into pure vertical motion. The castors run in the pathways of steel channels welded to the I beam base.

The transmission and turntable are designed and built for great strength and durability — yet simply enough for someone with welding ability to construct.

### E. Rotor

#### DESIGN

1. The rotor was designed to function downwind from the tower without a tail or rudder. This saves weight and expense, since a tail capable of keeping a 20-foot diameter rotor facing the wind must be very long and large. In addition, sails which are able to stretch back away from the wind during gusts are in danger of rubbing against the tower and catching or snagging when winds are strong. If the rotor is downwind from the tower, the stronger the wind, the further from the tower the sails stretch.

2. To overcome the disadvantage, relative to an American multi-blade, of one-to-one gear ratio in extremely light start-up winds, the rotor was made larger. Very little is added to the expense of a sailing rotor by extending the masts, for example, from seven to ten feet. However, since the area of a disc is quadrupled when the diameter is doubled, the increase of wind energy available to a 20-foot rotor is double that of a 14-foot rotor. This increment of wind energy is further augmented by the increase in mechanical advantage of a 10-foot lever arm over a 7-foot arm. The expense, complexity and weight of a gearbox is thus eliminated.

3. This sailing rotor is designed for both low and high winds:

a. *Design for low winds*

Large diameter rotor.

Four sails, each sail with wind-catching area of 21 square feet.

The choice to spread 84 square feet of sail, but not more, was made when the ideal solidity factors for slow speed water pumpers were balanced against the need to limit dangerous levels of drag in high winds. The experience of the research team in Omo, Ethiopia, that the coefficient of power (overall system efficiency) is more a function of windspeed than of number of sails deployed was also a consideration.

More experimentation needs to be done on best tip speed ratios and solidity factors for sailing windmills. The season-by-season functioning of this mill and testing of different pumping and air-compressing tasks will help in the further refinement of design.

b. *Design for high winds*

The primary design feature of this low-wind-sensitive, moderate-solidity sailing to withstand the exponential increases in energy in high winds is the flexible shock cord sheet connecting the outboard corner of the sail root to the successive mast. The shock cord brings the whole sail (from root to tip) into tension and, in

combination with the snout cord and fiberglass batten sewn into the sail root, creates the correct airfoil curve of the sail.

The second function of the shock cord is to allow the sail to stretch back out of the wind when a sudden large gust hits it, and to bend back spilling the majority of the energy it is receiving in winds above 20 mpb. The wind-spilling ability does not interfere with the regular pumping action of the mill – since, no matter how far downwind the sail is stretched by the wind, it always retains enough energy to pump at an efficient rate.

The second design factor allowing the sailing to withstand high winds is the fact that cloth sails are flexible and can be reefed (a five-minute operation) during stormy seasons. When reefed, approximately three square feet of sail remains deployed at the mast tips. In this condition, the mill will weather gale force winds and continue pumping the whole time.

A third factor of design for high winds is the ability to set the tips of the sails at an angle that is aerodynamically inefficient, thus creating luffing of the sail tips while the roots are being driven before the wind. The net effect of this precautionary technique is to prevent the rotor from overspeeding in high winds, exceeding tolerable centrifugal forces as well as tolerable stroke rate of the pump.

4. The rotor masts are coned downwind by wire-rope stays. The purpose of coning is to create extra rigidity in the mast. Coning is done downwind so that the effect of the pressure of the wind, which would be to bend the mast further, is counteracted by the tendency of centrifugal force to straighten it.

5. The sails are designed with 17-inch tips widening to 38-inch roots, with a catenary curve cut in the trailing edge. These proportions spread the energy of the wind relatively evenly over the length of the mast while the catenary curve prevents energy loss and noise due to vibration of the roach.

6. The tip booms are a new design worked out to provide extra torque in the light wind season by allowing a steeper than normal tip boom angle at start-up. Once the rotor is moving, the tips are designed to return automatically to the correct angle for efficient operation in motion. The final implementation of this tip design has not been accomplished as of this writing.

## CONSTRUCTION

1. The masts are standard 1¼ inch, 10 foot long TV antenna masts. These were chosen for their length, low cost (\$3.75 when purchased in June, 1977, as opposed to \$37.50 for aluminum spars of adequate strength) and for the ease in obtaining replacements with uniform weight.

2. Masts are stayed, front and rear, by 1/8 inch galvanized wire rope, 7 x 19 strands (for essential flexibility). At the 2/3 point on each mast, a wire rope connects it to the preceding and succeeding masts. Thus, in every direction where stress is encountered, the mast is braced. The stays provide a combination of compressive forces causing a curved downwind cone.

3. The rotor is removable from the windshaft by four bolts. A 2-1/16 inch ID steel pipe fits as a sleeve over the 2-inch windshaft. To this are welded four 9-inch sockets 1-1/8 inch ID into which are inserted the four masts. Mast ends have brazed beads for snug fit.

4. The new tip mechanism is created from an industrial castor with wheel removed, welded to 1-1/8 inch OD water pipe which inserts into the mast end — and welded as a T to a piece of light conduit to form tip boom and tip angle control weight mount. The tip boom rotates 360° on the castor double bearings when the sail is not lashed to it. It can be set manually at a given angle by inserting a pin, or left to work automatically by the action of the weight.

5. Sails are made of 5.4-ounce dyed Dacron<sup>(R)</sup> polyester cloth with Dacron<sup>(R)</sup> cord sewn into the trailing edge for strength and rigidity. Sail is lashed to the mast by Dacron<sup>(R)</sup> cord with flexible tubing inserts where the cord passes over the sharp edge of a grommet.

## F. Pump

### DESIGN

Purpose: to receive energy in the form, intensity and speed a 20-foot sailing delivers and to translate that energy into the movement of water to a high head.

Low speed demands a positive displacement pump. Centrifugal pumps require on the order of 1,000 rpm for efficient functioning.

Reciprocal action demands either a diaphragm or piston pump.

High head eliminates diaphragm pump. It has too many interior square inches for a head that produces 75 pounds per square inch.

A piston pump is ideally adapted to the vertical motion and length of stroke that a windmill can be made to deliver.

Experimentation in Omo, Ethiopia, concluded that two single acting, commercial windmill piston pumps, operating on a lever arm such that one was voiding while the other was filling and vice versa, increase the volume of flow a windmill can produce by virtually 100 per cent. They discovered that a mill is not significantly slowed when forced to pump on the down stroke as well as the up. We were not able to discover a commercial pump manufacturer who made a double-acting pump adapted to a windmill, so we decided to build our own. In the ITDG report on the Ethiopian research, a design is offered for a double-acting pump which, at the time of the report, had not been built. The pump for the Green Gulch Sailing was built from that design. In initial tests the pump has proved very well adapted to the windmill. Further testing and shake-down must still be made.

An added advantage was seen immediately in the double-acting pump: the outflow of water is smooth, with very little pulsing. This minimizes the danger common to reciprocal pumps used for high heads, in that they are subject to return shock waves from their own pulses, causing strain and sometimes damage. This is called the "water hammer effect."

The pump is designed with a 2-inch bore. This size was determined by calculations of the back pressure on the piston head due to a head of water eighty feet high. Although the mill was originally intended to pump fifty-two feet above the pond level and, in winter time, eighty feet to the large reservoirs, experience has made us hope that it can pump a head one hundred-fifty feet. If so, we shall be able to use windmill-pumped water in the irrigation sprinkler system which needs 75 psi, as well as the drip-irrigation system which uses only 15 psi.

Since we have three settings for stroke length on the crank disc, 5 inches, 8 inches and 12 inches, a bore of 2 inches may turn out to be right for such high pressures. A head of one hundred-fifty feet, creating 75 psi of static pressure on the face of the piston which is 3.14 square inches, is resisting the piston's motion with 235 pounds of force, not considering friction and inertia.

From testing so far we have no doubts that the mill will pump to the fifty-two-foot holding tank and the eighty-foot reservoirs as designed. In all likelihood, we shall be able to set stroke length for higher volume in winds of the 10 mph range.

### CONSTRUCTION

The pump was built from standard parts and pieces available in plumbing and pump-and-well shops. The barrel is a 16-inch section of 2-inch diameter PVC water pipe. Male adapters are glued to this, top and bottom, and screwed into galvanized iron T's at each end. Two 1-inch galvanized pipes with in-line check valves are connected to the T's at each end.

The sucker rod passes through a packing gland which prevents water, when under pressure in the upward direction, from leaking. The piston is equipped with two cupped leathers — one facing upward and one down.

With this design it is possible to disconnect one entry way into the pump so that it pumps on only one-half of its total stroke — and in place of the half stroke — connect another device, such as an air-compressing bellows for grey-water aeration.

This windmill is the most advanced of the New Alchemy sailwings on several counts:

1. It utilizes a far less expensive turntable of a quality equal to the 10-inch ID turntable bearing used on all recent NAI mills.
2. By the addition of a connecting rod, channels and rollers, the pump shaft runs vertically true throughout its length. This allows the shaft to be guided without significant friction and enables the mill to deliver full power on the compression stroke, a necessary condition for the use of a double-acting pump.

The connecting rod apparatus also makes possible greatly increased length of stroke — which allows high volume from a narrow bore pump.

3. The tower is designed with bowed cross braces under compressive load and a second platform. These eliminate the need for the interior guy wires. Tower work is thus more convenient.

4. Power in low winds is increased by the addition of one mast (four instead of three) and by a considerable increase in sail area for each sail.

5. Sail design is improved:

- By the use of 5.4-ounce Dacron<sup>(R)</sup> sails instead of 3.8-ounce, which should increase the life of the sail.
- Instead of a root boom, as on earlier NAI mills, or a simple shock cord as on the most recent one, the Green Gulch Sailwing has a fiberglass batten sewn into the root edge of the sail. The shock cord is connected directly to this and to the sail, and an additional cord leading out to the snout of the rotor from this point holds the sail root permanently at 22° (except when high winds increase the angle) and keeps the batten bowed to create a correct airfoil in faint breezes.
- A catenary curve is reintroduced (early NAI sailwings had it) and a firming Dacron<sup>(R)</sup> cord is sewn into the trailing edge.

6. A tip boom mechanism was designed for the New Alchemy Sailwing three years ago, which was to allow the tips a steep pitch out of the plane of the disc for increased start-up torque, then would, as centrifugal force increased, move the tip into the wind for best operating angle. The mechanism was not reliable as constructed, although the concept may not have been faulty. In addition, it was found that in the brisk and erratic winds of Cape Cod a wind-spilling tip mechanism was of greater use than an efficient tip angle so the mechanism was turned backwards to increase the angle out of the plane of the disc with increased speed. However, this mechanism was, in all events, too complex.

The gyroscopically-controlled tip booms, designed for the Green Gulch Sailwing, could prove to be an advance. They are simpler in concept and design, with only one moving part. Final experimental determination of the correct weight for the tip and construction of the weight-mounting device were not achieved as of this writing. This was simply due to the absence of windmill personnel for the first month after initial testing was to have begun. It was not possible to determine the correct weight for the gyroscopic lever without actual tests on the machine. Experiments with a small-scale model of the tip-boom mechanism were successful.

The tip booms as constructed can also be set manually at various angles, either for greatest efficiency and power or for different amounts of drag to prevent overspeeding.

7. With the introduction of the four-masted rotor, it becomes possible to reinforce each mast laterally by connecting it to the preceding and succeeding masts with 1/8-inch wire rope at a point 2/3 mast length from the root.

8. The double-acting pump is an improvement over all pumps New Alchemy had tried with the sailwing up to the spring of 1977. It allows high-head pumping with low back pressure for start-up and allows a range of volumes per stroke from 0.14 gallons to 0.32 gallons. It is tailored to the kind of power this sailwing produces both in form and intensity. It is specifically designed for high-head pumping.

Due to absence of personnel after the completion of the windmill construction, only minimal testing has been done. It was discovered that, with an 8-inch stroke, pumping nine feet up from the pond and directly out into the squash patch at the base of the tower, the mill began pumping in 6 mph winds and continued pumping in an average of 3 mph. It need not be said that this is an extraordinarily light wind for the performing of any useful work.

Testing of revolutions per minute on two occasions has shown that, with a moderate load (12-inch stroke pumping 35 feet above the pond) the tip speed ratio was 3.6 and did not change as the windspeed changed. Tip speed ratio is the ratio of the speed of the wing tips to the speed of the wind. In this case, the tips were travelling 3.6 times faster than the wind. This is a somewhat higher ratio than normal for a water pumper, but such speed is a disadvantage only when it translates into too little torque for light wind start-ups - or when it sends the mill into overspeed in high winds. With the aerodynamic brake (tips set at inefficient angle) and shock cord spilling of excess wind, the mill should prove to be protected against overspeed in winds up to 40 mph. As for starting torque, we have already seen that it is excellent.

It is to be expected that, when the mill is pumping up 50, 80 or even 150 feet, the tip speed ratio will be reduced to normal levels, between 2 and 3. Tested tip speed ratio with no load (pump disconnected) was 4.7.

Informal observation in winds estimated between 40 and 50 mph reveals that the rotor rpm reaches a peak at around 55 and then *slows down* as the winds rise further. This is due to the loss of airfoil when the shock cords are significantly stretched.

A rough idea of the volumes of water flow to be expected in various winds can be had from tests with a 12-inch stroke pumping 35 feet above the water source:

Windspeed (mph)	Rotor rpm	Gallons per minute
5	24	7.68
6	30	9.60
9	42	13.44
10	48	15.36

Now it is obvious to the Green Gulch community, to its many visitors and to those who drive by on Highway 1, that the winds just above the floor of the Green Gulch valley are capable of performing useful work. The development of other practical wind devices, especially to take advantage of the stronger winds found on the hillsides and hilltops, becomes a natural step. Small mills to do single specific tasks can be designed and built wherever they are needed, providing tangible working examples of a gentle, humane and enduring technology.

The Green Gulch Sailing was designed and built by Tyrone Cashman with help from:

Kenneth Sawyer      Eric Larson      J. Baldwin  
Barton Stone        Jack Park        Harry Roberts

#### BUDGET

As of this writing, the expenses for materials were wholly available but not all the hours of labor to the completion of the mill had been tallied.

<u>MATERIALS</u>	<u>COST</u>
Lumber for the tower	\$116.64
Windshaft bearings	75.66
Steel for transmission	92.78
Castors for pump shaft	18.28
Tip boom castors	29.82
Rod end bearings	21.26
Steel disc for crank	7.42
Parts for pump	146.28
Bolts and Loctite	3.28
Wire rope, 146 ft.	30.73
Nuts, washers, bolts	8.72
Nuts and bolts	4.86
Misc. hardware	10.51
Turnbuckles and thimbles	5.90
Paint and clamps	13.49
Tail pipe clamps (for booms)	3.18
Antisize compound	1.00
Stainless steel banding	25.02
Drill bits and files	25.61
Tower paint	15.96
Extra tower paint	15.96
Aluminum sheet for cowling	25.44
Sailcloth	68.42
Extra sailcloth	9.27
Rotor hardware	56.69
18 bobbins thread	4.77
Fiberglass battens	18.83
Dacron <sup>(R)</sup> Rope	1.90
Shock cords	14.36
<u>OUTSIDE PROFESSIONAL LABOR</u>	
Machining on windshaft/crank	70.00
Threading connecting rod	17.50
Pump alignment and assembly	40.00
<b>TOTAL</b>	<b>\$999.54</b>

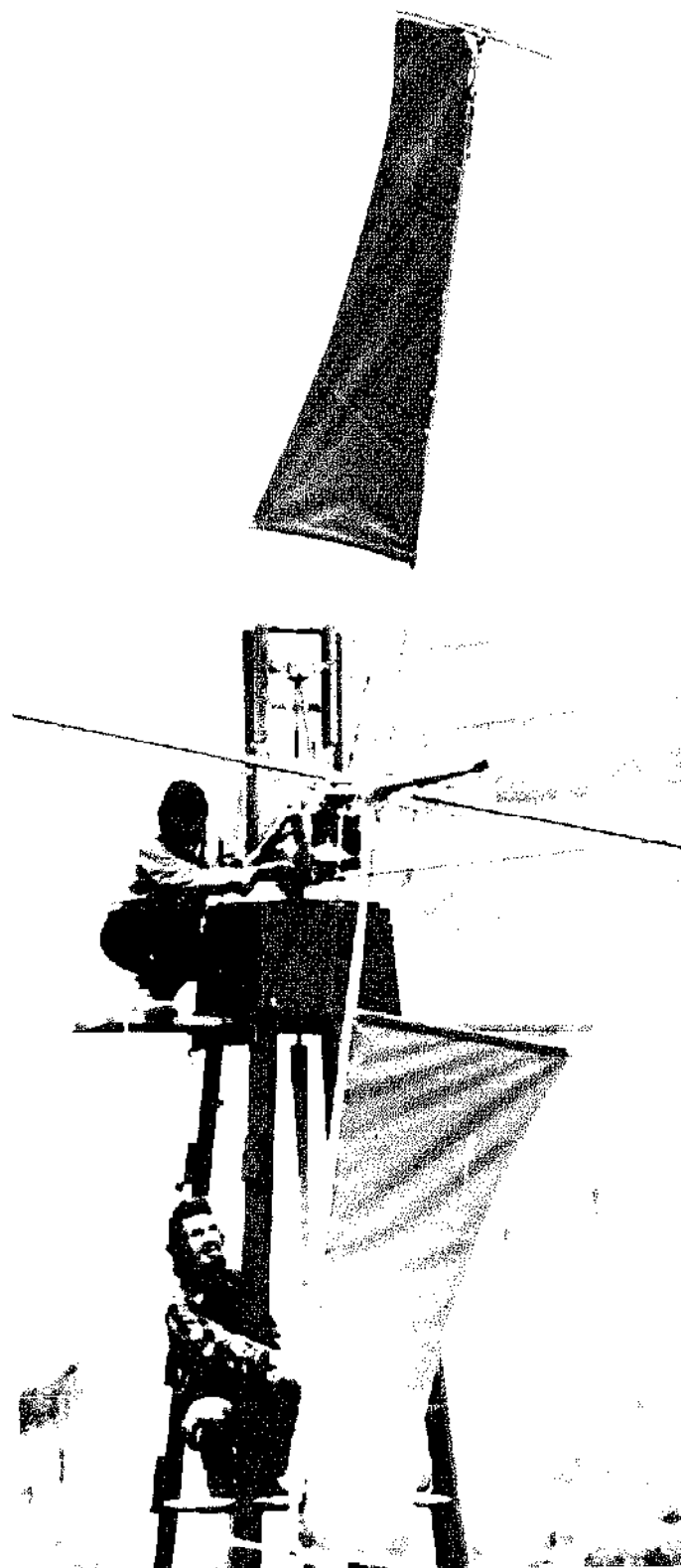

# New Alchemy Hydrowind Development Program

— Joe Seale

The Hydrowind<sup>®</sup> project began in 1975 as a part of the energy resources for the Ark on Prince Edward Island. An immediate Hydrowind goal was to provide the wind energy component of the Ark's natural energy systems. A longer range goal was to develop a windmill with commercial potential that would be within the economic reach of a family but large enough to deliver worthwhile quantities of electrical power. The first prototype mill — Hydrowind 1 — is fulfilling performance expectations but will require substantial design simplifications to meet criteria for low cost and simple maintenance. This article surveys the results of the Hydrowind program and indicates new directions emerging from current research.

The innovative aspect of the Hydrowind system is the use of a hydraulic pump at the top of the mill to receive power from the rotor and deliver the power in the form of pressurized hydraulic flow to ground-based equipment. Of the many alternative means of using hydraulic power on the ground, electricity generation was chosen for simplicity, versatility and complementarity to most equipment used in modern dwellings.

To generate electricity, a hydraulic motor driven by the flow of fluid from the top of the mill turns a permanent field, brushless electric generator. The alternating current from the generator varies in both voltage and frequency with windspeed changes and is incompatible with the fixed voltage (115 volts) fixed frequency (60 cycles per second) utility lines. To overcome this incompatibility, an electronic synchronous inverter transforms the wind-generated electricity to the proper voltage and frequency and combines it with electricity from the utility. The installation obviously is not therefore designed for stand-alone operation, but instead substitutes wind power for utility power in the amounts available from the mill. When wind generation exceeds the Ark's consumption, surplus power goes out through the utility lines and becomes an input to the power grid. Under these conditions, the windmill is like the many other electric generators linked together by the power grid, each adding its contribution to meet the overall demands of houses and industries tied to the grid.

To limit maximum rotor speeds, the machine uses a hydraulically-driven piston to control the pitch of the rotor blades. The piston, in turn, is controlled by a hydraulic valve operated by centrifugal weights (Figure 1) in a mechanism analogous to the flyball valves that vent steam to govern a steam engine.



Photo by John Taad

## HYDROWIND 1 SPECIFICATIONS

Tower: 40 ft. Donlite angle iron tower

Rotor type: horizontal axis, 3 blade, variable pitch turbine  
Rotor dimensions: 20 ft. swept diameter, 15 in. constant chord blades

Maximum rotor speed: 125 RPM for winds above 22 mph.

Maximum electrical power: 4 KW for winds above 22 mph.

Power transmission stages:

- 1) 3 to 1 timing belt step-up from rotor shaft to swash-plate piston pump
- 2) pump hydraulic output drives hydraulic motor for additional speed step-up of 2.5 to 1, yielding net effective gear-up to generator of 7.5 to 1
- 3) hydraulic motor drives permanent field brushless AC generator
- 4) generator interfaces to AC power lines via Gemini synchronous inverter

Governing stages:

- 1) centrifugal flyballs open pilot operated hydraulic valve (unit by the Woodward Governor Company)
- 2) valve opening controls spring return of pitch control cylinder
- 3) pitch control cylinder controls cam-followers regulating blade pitch

Failsafe: Loss of hydraulic pressure always causes blades to return to full feather. Thus, pump failure or broken hydraulic line feathers mill. Automatic hydraulic pressure dump to feather blades is triggered by hydraulic over-pressure (indicative of mechanical or governor failure) or by excess vibration.



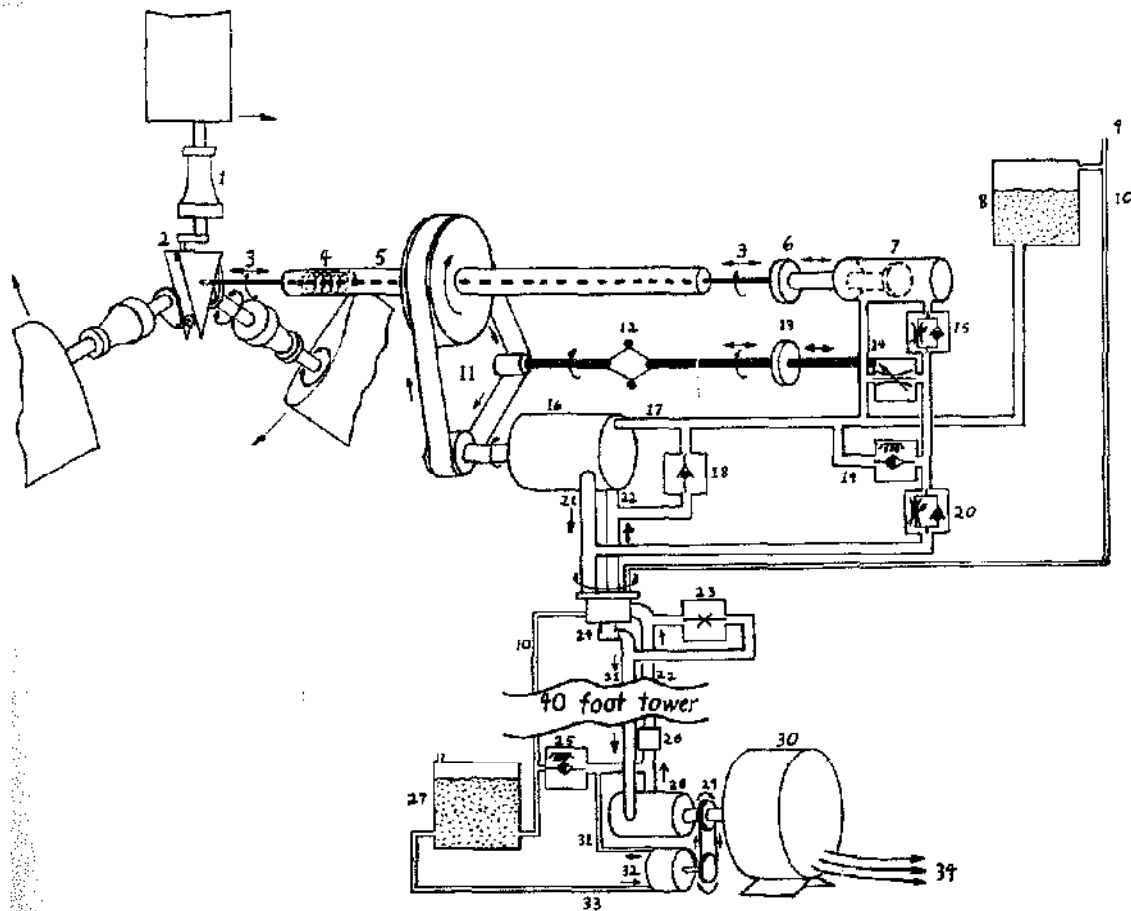

FIGURE 1 - Key -

- |  |   |
|--|---|
| <p>1: Spindle (one of three) with pitch change bearings - this assembly is structurally joined to drive shaft (5).</p> <p>2: Cam follower (one of three) - causes blades to pitch back when pitch control rod (3) moves to right.</p> <p>3: Pitch control rod.</p> <p>4: Pitch return spring (compression; dotted line, inside drive shaft, pushes pitch control rod (3) to right).</p> <p>5: Rotor drive shaft.</p> <p>6: Thrust bearing.</p> <p>7: Pitch control piston and cylinder.</p> <p>8: Hydraulic oil reservoir.</p> <p>9: Air inlet - siphon break.</p> <p>10: Reservoir overflow drain line.</p> <p>11: Timing belt and pulley assembly - from drive shaft gives 3 to 1 step-up to hydraulic pump (16), 6 to 1 step-up to flyball governor (12).</p> <p>12: Flyball governor assembly consists of flyballs (12), bearing (13), and hydraulic pilot valve (14) which opens when shaft from flyballs moves left. When valve opens, it allows fluid flow to left through it, permitting hydraulic piston (7) to move to right under force of pitch return spring (4) causing blades to pitch back. (Governor is a single enclosed manufactured unit.)</p> <p>13: (13), and hydraulic pilot valve (14) which opens when shaft from flyballs moves left. When valve opens, it allows fluid flow to left through it, permitting hydraulic piston (7) to move to right under force of pitch return spring (4) causing blades to pitch back. (Governor is a single enclosed manufactured unit.)</p> <p>14: When valve opens, it allows fluid flow to left through it, permitting hydraulic piston (7) to move to right under force of pitch return spring (4) causing blades to pitch back. (Governor is a single enclosed manufactured unit.)</p> <p>15: Needle valve with one way check valve - needle valve limits rate at which pitch control piston moves to left, while the check valve permits rapid motion of piston to right to feather blades.</p> <p>16: Hydraulic pump - swash plate, 7 pistons.</p> <p>17: Case drain for pump - pressure inside pump and leakage around pistons cause flow from case drain to keep reservoir (8) filled.</p> | <p>18: One way check valve permits flow from reservoir (8) to keep return line (22) filled when mill is not running.</p> <p>19: Pressure relief valve limits maximum pressure to governor valve (14).</p> <p>20: Needle valve with one way check valve - the needle valve acts as a pressure divider in conjunction with governor valve (14) while check valve permits rapid return of pitch control piston to right (feathering blades) when hydraulic pressure drops suddenly, as when bypass valve (23) opens.</p> <p>21: High pressure line from hydraulic pump to hydraulic motor.</p> <p>22: Low pressure return line.</p> <p>23: Electrically operated bypass valve - opens when voltage is removed, dumping high pressure to return line and causing rapid feathering of rotor blades.</p> <p>24: Hydraulic rotary union - permits top of windmill to turn to track wind without rotating hydraulic lines to ground.</p> <p>25: Pressure regulating valve - maintains constant low pressure on hydraulic return line (22) during pump (16) operation, keeping the line filled with slight pressure at top to prevent pump cavitation while holding check valve (18) closed.</p> <p>26: Oil filter.</p> <p>27: Main hydraulic oil reservoir.</p> <p>28: Hydraulic motor.</p> <p>29: Belt drive from hydraulic motor (28) shaft to booster pump (32).</p> <p>30: Electric alternator - 3 phase, fixed field, brushless.</p> <p>31: Output line from booster pump - carries low volume, low pressure flow to pressurize main return line.</p> <p>32: Hydraulic booster pump.</p> <p>33: Return line to booster pump.</p> <p>34: Three phase AC electric lines to Gemini synchronous inverter, the Ark, and the power grid.</p> |
|--|---|

To gain perspective on the relative merits of the existing Hydrowind machine and proposed modifications to it, we need to explore some of the efficiency and control characteristics of horizontal axis windmills. Power available from the wind varies constantly from too little to use to enough to destroy a wind machine. Therefore, efficiency and control design problems split into two categories. When windspeed is insufficient to cause structural damage or power plant overload, emphasis falls on efficient extraction of the largest possible fraction of the power potentially available in the wind moving past the rotor. For higher winds, design emphasis shifts to protecting the rotor, tower and power plant (generator, pump, etc.) from overload. As a secondary emphasis, once safety is assured, the wind plant should recover from high winds the largest possible fraction of the maximum power it can safely handle.

Considering first the high-wind design questions, there are four important methods used singly or in combination to limit: a) rotor speed or power and b) disc drag, the axial wind force that bends rotor blades and the tower.

1. *Blade feathering*, the governing mechanism of Hydrowind I, is the most commonly used method on large windmills. At full power operation, the flats of the rotor blades lie nearly in the plane of the rotor disc (Figure 2a), cutting across the wind and catching its full force. Part of the aerodynamic blade force lies tangential to the rotor disc and generates

torque, while the other, generally larger, disc drag component exerts its force downwind parallel to the rotor axis, delivering no power (Figure 2a). Feathering the blades back (Figure 2b) reduces the aerodynamic pitch angle, which reduces blade lift, thus decreasing both rotor drag and torque. If pitch is adjusted to maintain constant rotor speed and torque with an increased wind through the rotor (Figure 2c), an increased fraction of the total blade lift vector becomes torque, so that total blade force becomes smaller, and both blade bending forces and tower forces actually decrease with increasing wind at constant power. Blade feathering has the potential of minimizing blade and tower stresses while maintaining full power, thus ideally fitting both criteria for governing. However, if rotor blades feather in response to rotation speed alone, gusts can cause severe stresses.

Suppose that a rotor is operating slightly below governing speed when the wind increases suddenly. Rotor drag immediately increases, but at first the extra torque goes into speeding up the rotor. Thus, rotor speed and shaft power levels at first remain within safe limits as the rotor accelerates soaking up the extra wind power, but the blades and tower experience stresses associated with the greatly increased total wind power.

There are two ways in which a blade pitch control governor can prevent high gust stresses. One method is to use a conversion plant, almost always a synchronous operation electric generator tied directly into an AC power grid, that forces the rotor to turn at rigidly constant rotation speed. With a synchronous generator, the frequency of the power grid enforces a lock-step constant speed rotation on the generator, and the generator, in turn, enforces a proportional constant speed (depending on gear ratio) on the rotor. Blade pitch is then controlled by feedback to maintain constant generator power output, which amounts to regulating pitch for constant rotor torque. Any change in torque causes only a brief transient change in rotor speed after which the power lines reimpose fixed rotation speed at a slightly different phase angle relative to power line phase (Figure 3). Because the rotor is held so rigidly to fixed speed, any wind change is reflected with little delay in a change of generator power. This makes possible rapid feathering response to gusts.

Hydrowind I is not a synchronous operation windmill, so constant speed power governing is inapplicable. The only alternative is to make blade pitch responsive to wind force on the blades or, through some mechanism, responsive to measured wind near the rotor center. The New Alchemy sailing windmill responds to force on its sails through the elastic mounting of the sails, so that they give way to high wind forces and spill air. But the Hydrowind I blades are not constructed and pivoted to tend to feather passively under stress, so

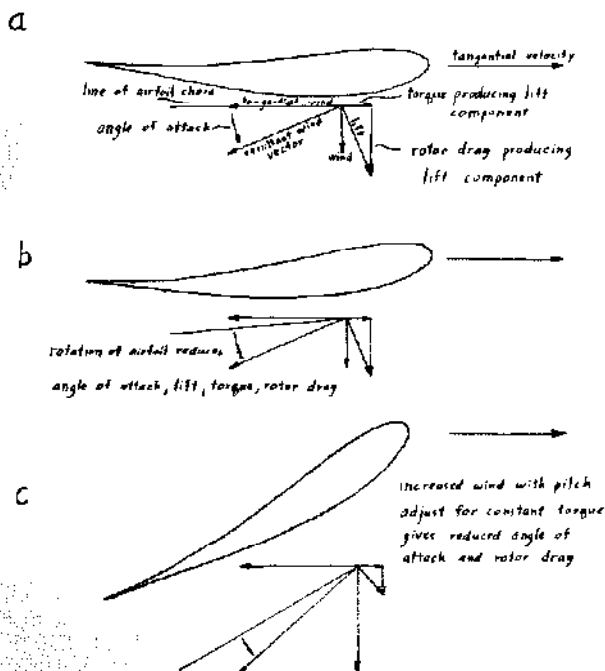

FIG. 2

the only alternative would be a complex automatic control system responsive to both rotation speed and either blade stress or windspeed. Such a mechanism would be difficult to make reliable and would not be worth the expense. Confronted with this problem, we opted to derate the governor-limited maximum rotation speed of the mill to a value where a second governing mechanism would protect the blades and tower: aerodynamic blade stall.

2. *Aerodynamic blade stall* is the second of the four major governing methods over

- a) speed or power and
- b) rotor drag

When lift-generating flow which follows airfoil contours breaks down at high angles of attack, stall results (Figure 4). As airfoil angle of attack increases up to the stall region, lift increases in proportion to angle of attack while airfoil drag (not to be confused with rotor drag, which results primarily from airfoil lift forces) is very low. As flow separation sets in, airfoil drag increases sharply while lift decreases. Airfoil drag operates in such a direction as to reduce the tangential or torque-producing force of an airfoil. Thus, stall of all or a part of the length of windmill blades will reduce torque and rotor drag. If rotor speed is held constant, then increasing wind speed will cause increasing blade angle of attack and ultimately blade stall. (Note Figures 2b and 2c, where blade angle of attack would have increased going from 2b to 2c if the blade had not pitched back to maintain constant torque.) When blade stall progresses through a rotor, torque may increase, remain about the same, or decrease, depending on blade shape. If a rigid, fixed pitch rotor has any starting torque, then sufficiently high winds will ultimately result in unsafe torque levels, but care in design can assure that "sufficiently high winds" means winds unlikely to occur during the life of the mill. Rotor drag increases are slowed by blade stall, but, as with torque, sufficient winds will produce rotor drag exceeding levels encountered before stall. Thus, design of stall-governed rotors must conform with the built-in limits of the stall mechanism. That design within these constraints can be successful is borne out by two well-tested stall-governed windmills, the 200 KW Danish mill at Gedser, and the 150 KW mill being tested at Cuttyhunk Island, Massachusetts.

For aerodynamic blade stall to operate, some other mechanism must first limit rotor speed. Otherwise, the rotor blades would continue to speed up with increasing wind, which would prevent increases in blade angle of attack. The usual mechanism for large windmills feeding into a power grid is the phase-lock property of generators connected to an AC grid, as was discussed in relation to power governing by blade pitch control. However, there are many types of wind energy conversion plants that can be designed

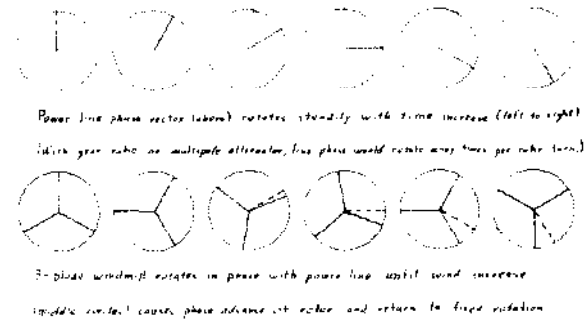

FIG. 3

to present a steeply increasing load on the rotor above some predetermined rotation speed. One such alternative can be accomplished through adjustments in the Gemini synchronous inverter such as Hydrowind I uses. There are numerous possibilities for back-torque speed governing in stand-alone units. Some of these possibilities are the subject of future New Alchemy research plans.

3. *Rotor yaw control* is the third governing mechanism, whereby a rotor disc is turned out of perpendicularity to the wind to reduce the component of wind crossing the rotor disc. (Figure 5 depicts a simple passive yaw control mechanism.) There is a major limitation to the effectiveness of rotor yaw control: the gyroscopic inertia of a spinning rotor limits the speed with which it is possible or safe to reorient the rotor. Winds can change direction faster than a rotor can reorient to avoid the perpendicular force, so there are times when blade forces are limited only by stall. Provided a rotor is strong enough to withstand maximum forces, yaw control can govern rotor speed, though such a system will allow significant speed variation during the time lag between windspeed changes and adjustments in rotor heading.

4. *Aerodynamic spoilers* reduce rotor airfoil efficiencies by disrupting flow and causing turbulence and blade drag. A very small tab automatically extending from a rotor blade upper surface and cutting straight

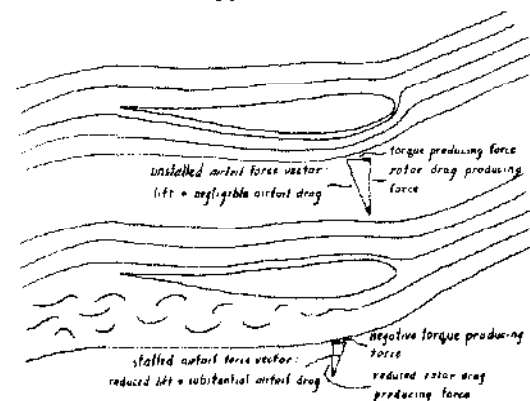

FIG. 4

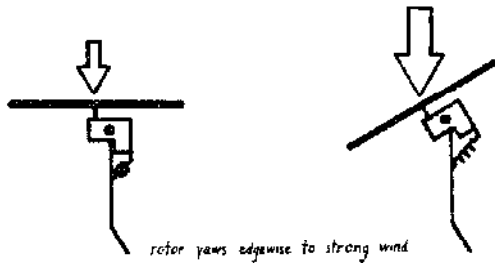

FIG. 5

across the wind flow can suffice to slow a rotor. Automatic spoilers can govern rotor torque or rotor speed but generally not rotor drag, so spoiling relies on blade stall to limit rotor drag.

Having considered high-wind protection and governing, we now come to the area of efficiency maximization in safe winds. Any windmill will be most efficient at one particular rotation speed for any given wind-speed. Optimum rotor speed always varies almost exactly in proportion to wind-speed. Define tip-speed ratio,  $\tau$ , by

$$\tau = \frac{\text{rotor tangential speed}}{\text{windspeed}}$$

Then constant optimum proportionality between tip-speed and windspeed implies that optimum efficiency occurs at a fixed tip-speed ratio.

Define coefficient of performance,  $C_p$ , by

$$C_p = \frac{\text{recovered power}}{\text{power in the wind}}$$

where "power in the wind" means kinetic energy per unit time contained by the air moving undisturbed past an area equal to rotor disc area. Empirically,  $C_p$  is a function only of  $\tau$  (see Figure 6 for examples) and is virtually independent of wind-speed at fixed  $\tau$ . Betz's limit, .5926, is a widely accepted theoretical upper limit to achievable  $C_p$ , and .4 is considered a good practical  $C_p$ .

$C_p$  is zero at zero tip-speed ratio because a windmill that is not turning ( $\tau=0$ ) cannot deliver power. However, starting torque of a rotor may be critical for getting a load unstuck and moving in order to make blade power transfer possible. Positive displacement pumps (whether air, water or refrigerant) operating against a pressure

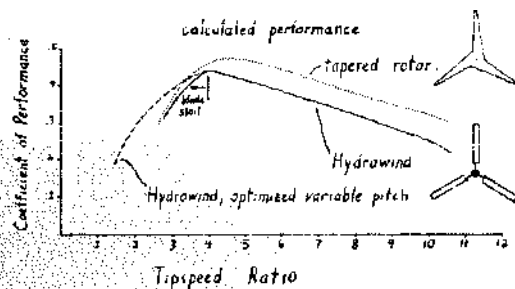

FIG. 6

head always present special low speed torque requirements for a windmill, with the result that mills designed for pumping tend to look quite different from, say, electricity-generating mills. High starting torque requires large blade area with the blades pitched back typically at least 30°. If the pitch of such blades is fixed, then torque and  $C_p$  reach zero at  $\tau=2$  or less. With pitch control designed to flatten blade pitch as  $\tau$  increases, a high starting torque rotor can operate efficiently up to tip-speed ratios of 5 or 6. Thus, a pitch optimizing windmill is potentially versatile at delivering power to loads with differing torque requirements.

The blades of Hydrowind I have sufficient area to develop good starting torque when pitched back. The blades always come to full feather when the mill stops or when, for any reason, hydraulic pressure drops to near zero at the pump outlet. Thus, this mill can start high starting torque loads. And, as long as load torque increases with rotation speed, this mill will smoothly flatten its blade pitch with increasing wind-speed, rotor speed and load torque, until it achieves the maximum allowed pitch angle. (See Figure 1 for the hydraulic pitch mechanism.) At maximum pitch, Hydrowind I's blades perform efficiently over a broad range of tip-speed ratios (Figure 6). In fact, the proportions of Hydrowind I's blades are ideally suited for performance optimization through pitch control with "difficult" loads such as pumps and compressors. Also, Hydrowind would fit well into most electricity generating loads if blade pitch angle remained fixed at the highest pitch setting.

Despite Hydrowind I's high potential versatility, there are two common load types for which it is difficult or impossible to achieve optimal pitch control. First, there are problems with loads of virtually constant back torque at any shaft speed. Constant back torque implies constant hydraulic pressure, which, in turn, implies constant pitch (Figure 1). No adjustment to the pitch control mechanism can cause pitch to vary in an efficiency-producing way for such a load, which is characteristic of load curves for most pumps and compressors. The second problem arises with loads that produce very little low speed back torque. Such loads include centrifugal water pumps operating to overcome a significant static head and electrical generators operating into some loads, particularly through rectifiers to batteries. With little back torque and back hydraulic pressure, the rotor blades remain at full feather, so the rotor cannot possibly turn fast except in storm winds. Without turning fast, the system cannot develop hydraulic pressure. So, the system is stuck at full feather. It is possible to remedy either of these problems through hydraulic controls at the bottom of the mill. For example, an appropriately controlled servo-valve could provide hydraulic back-pressure at

low flow rates only, thus allowing the mill to start with low starting torque loads. In the case of constant torque loads, a variable displacement hydraulic motor could modify the mechanical advantage of the rotor on the load and cause pitch to vary. But once one starts adding hydraulic load-adapting controls, the need for pitch optimization vanishes. With adaptations of standard hydraulic components, it is possible to match virtually any type load to a fixed pitch rotor.

Fully debugged, the hydraulic pitch control mechanism on Hydrowind I has cost far more than the hydraulic power transmission. As we have suggested, relatively simple controls in the transmission itself in move toward eliminating the need for pitch control. On this basis, we intend to abandon pitch-controlling mechanisms on future projects and concentrate

- a) developing an optimum rigid rotor system and
- b) developing load adaptations that allow a rigid rotor to operate efficiently and be speed-governed by the load.

Hydraulic power transmission should play a key role in some but probably not all load adaptation problems we can anticipate. While some special tasks might be accomplished best without hydraulics, we suspect that hydraulic power transmission will be the best solution for an adaptable, economical general-purpose windmill.

In the rigid rotor development area we are examining the advantages of tapered rotor blades. The broad blade tips of Hydrowind I contribute starting torque at full feather, but at fixed maximum pitch, which would be the only pitch for a rigid rotor, the large width of the tips detracts from aerodynamic efficiency at all speeds. Not only would narrow tips work more efficiently (Figure 6), they would develop lower peak forces at maximum lift angle simply because of reduced tip area. This implies significantly less bending stress in the blade roots as well as in the tower. The blade construction of Hydrowind I is not adaptable to tapered plan form. The most likely candidate for tapered blade construction is fiberglass lay-up.

In the load adaptation area, we are examining several non-electric tasks adaptable to wind technology: water pumping, air pumping, heat pumping (i. e., refrigerant pumping), refrigeration and heat generation by friction. Air and refrigerant pumping have the greatest need of hydraulic transmission approaches. Water pumping is probably best accom-

plished by mechanical drive through a vertical shaft to a centrifugal pump designed to govern windmill speed by a steeply rising torque curve. Friction heating uses fluid friction and a similar centrifugal pump speed governor concept. The property that lends great interest to these particular thermal and water pumping windmill tasks is storage. Pumped water can be stored for later use in an elevated or pressurized reservoir. Heat can be stored in low grade form in water and in higher grade form in heat-of-fusion of paraffin wax or sulfur. Cold can be stored in heat-of-fusion of substances like ethylene glycol, so that food freezers can be kept well below freezing during periods of no compressor power. Electricity remains expensive to store, so storage of other forms of energy holds great interest.

We expect our next major windmill construction project to result in a rigid tapered rotor to be controlled by a redundant combination of load control of rotor speed, yaw control of rotor speed, a mechanical brake to control rotor speed, and stall to control stress. The design should be much simpler and more economical than Hydrowind I.

In all the designs we are considering, we anticipate a fusion of high and intermediate technologies. Components like hydraulic pumps and transistors are available from industry and there seems no good reason to forego their use in domestic designs, but, for an economical windmill that can be built and repaired in shops of moderate capital investment, the high technology components must be standard production units that fit, in modular fashion, into a relatively simple structural framework. Further, the workings of the mill should be easy enough to see and understand that a windmill owner/operator with minimal training can keep the mill running. Some of the mechanisms of Hydrowind I have required precision machined components not available off-the-shelf, and this presents a formidable economic barrier to establishing small scale production. The machine has failed to be an encouragement to innovators who have come to examine and learn from it. Instead, it has taken on that inscrutable complexity of technologies like automotive emission control equipment with the unwritten message in the very structure (often reflected in the label): "Hands Off. Refer Service to Qualified Professionals Only." We have learned that there are simpler ways to make a windmill, ways that encourage a broader-based, more diverse and stable participatory technology.

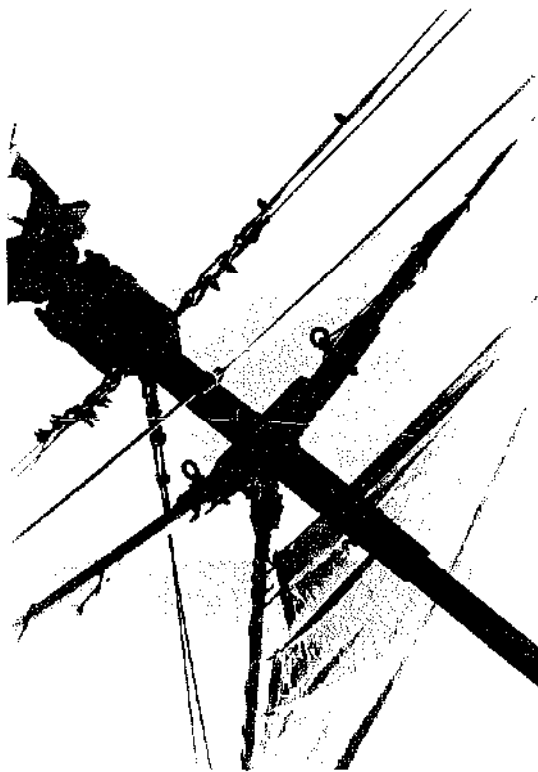

Photo by Mike Mungoy